

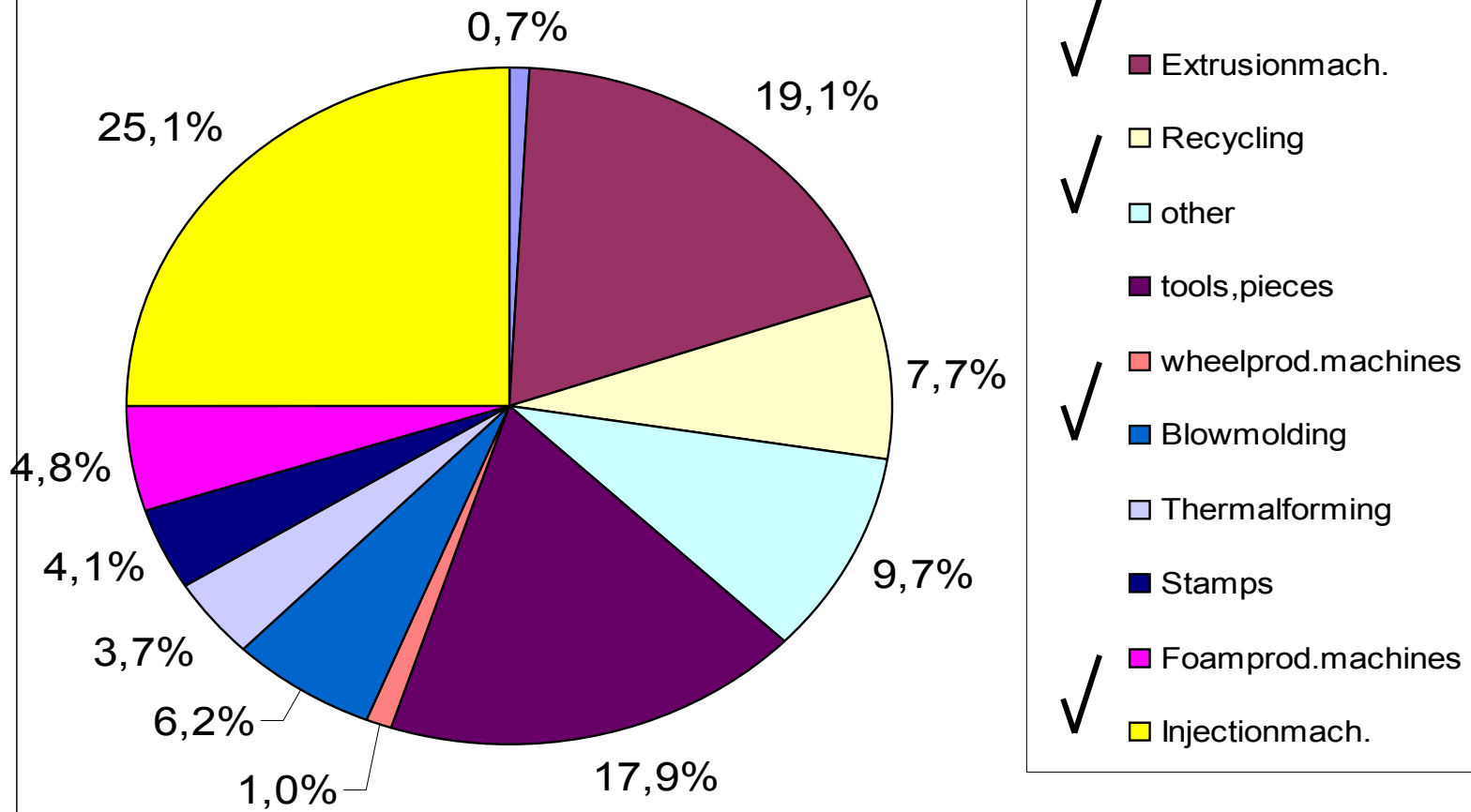

Key Account Automation

Plastic market segment

Plasticmachines





What we have done...

Solutions for the targetmarket

- ISR - controller solutions
- solutions for handlingapplications



Complete solutions incl. panelbuilding aso for machines and plants.

- consulting
- construction
- doing

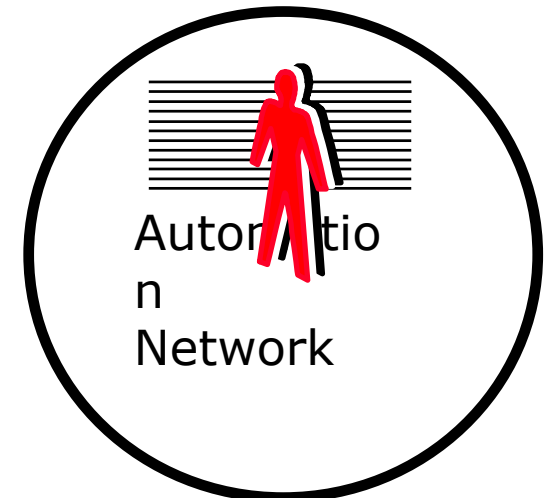



Strategic Alliance

- **Development of special components**
- **High flexibility and Know-How for the joint development of advanced solutions**
- **goit together as ` Plastic to the power of two`**



+

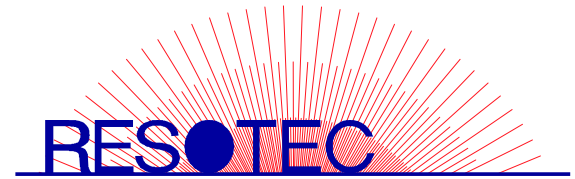

=





Strategie

Mitsubishi Electric receives a clear profile inside the market:
Supplier for complete solutions and 'Packages' for plastic machines

Extrusion
ExtrusionPack }

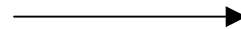

Blowfoilproduction
BlowfilmPack }



Extrusionblowmolding
BlowmoldingPack }

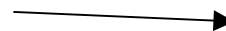



Production of plastic material with Extrusion machines

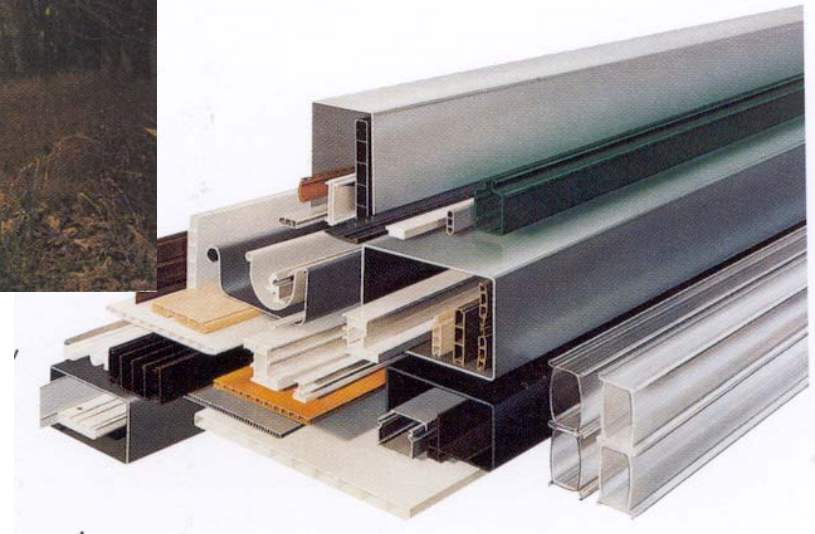



ExtrusionPack } }

**Plug & Play
Solution for the
Extrusion**



A complete product range

ExtrusionPack²

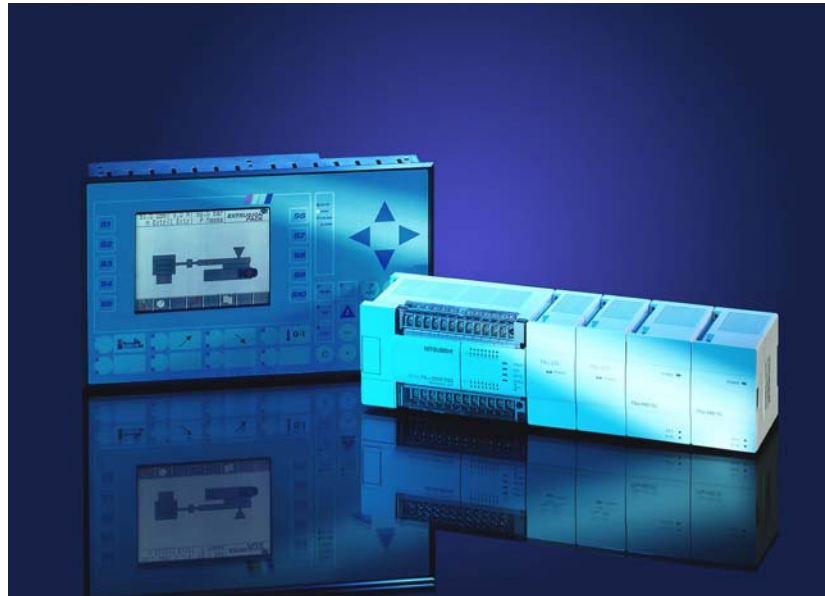



ExtrusionPack²

- is a complete solution for
- Extrusion machines
- PLC and HMI are readily programmed
- PLC and HMI are supplied as a package
- A unique concept ! Plug & Play !
- There is no programming needed. The user configures the machine on the screen

Configuration instead of programming !





ExtrusionPack² has clear advantages against the competitors !

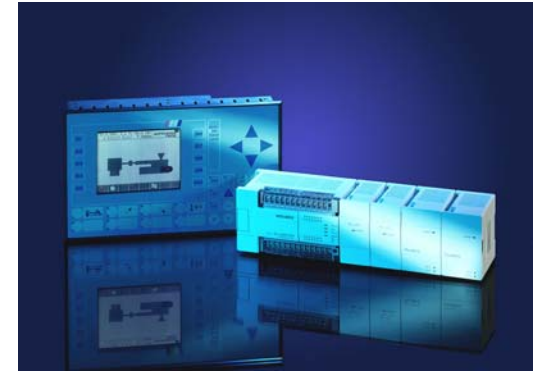

- **Unique customer oriented concept**
- **Market acceptance**
- **High sales margin**
- **Less support**
- **Dooropener for other components**



Professional

Com fort

Basic

Mini



> 30 Zonen

10-30 Zonen

10-20 Zonen

< 8 Zonen

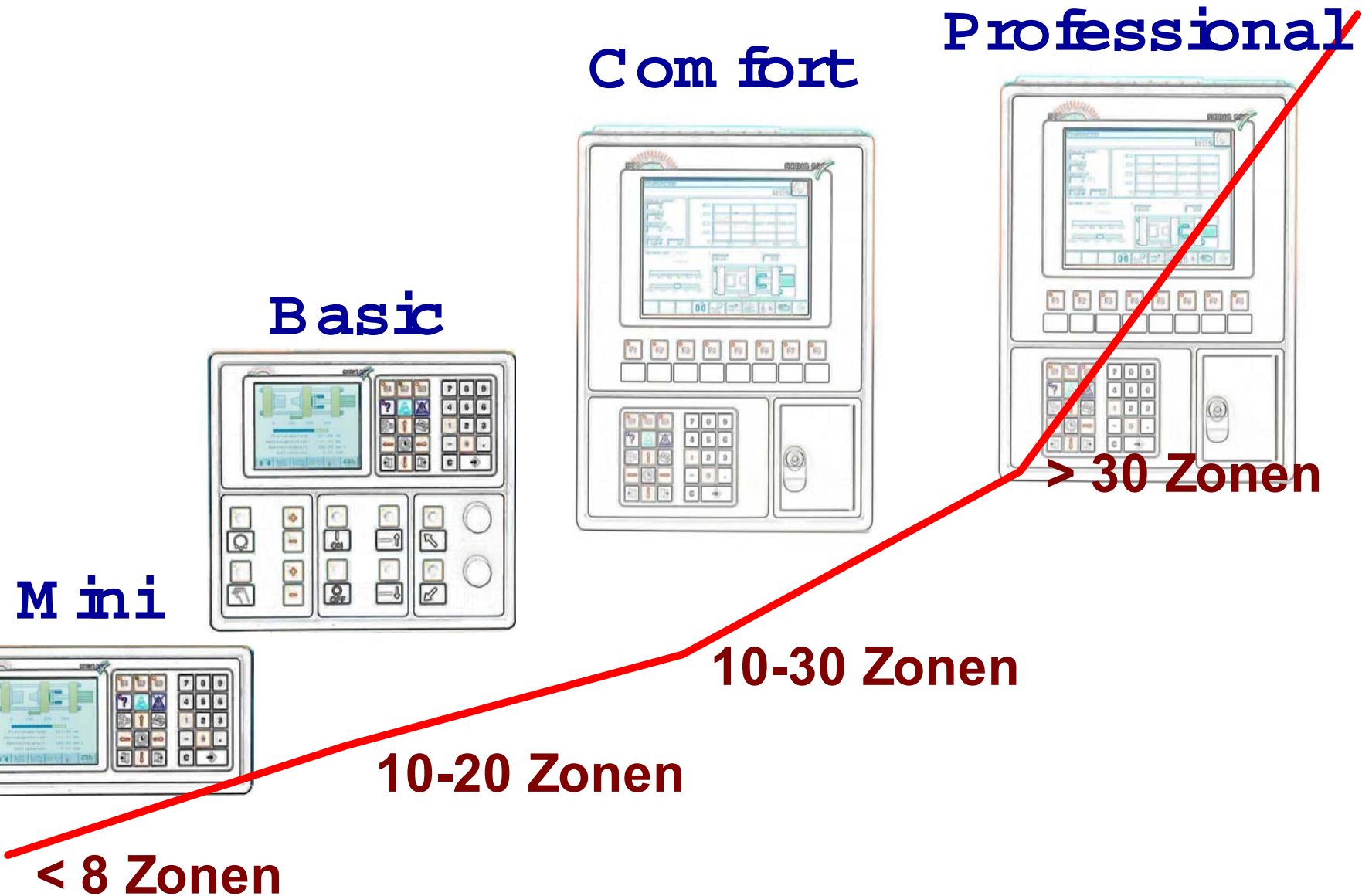



Special developments





Special development for the screw temperaturecontrol



- Temperaturecontrol module RE-10-TC
 - FX2N - Functionmodule
 - parametrisation via To/From instructions
 - 10 Thermocoupleinputs or 0-10V and melttemperaturinput
 - 10 closed loops all H / C
 - Autotuning
 - H / C outputs on board
 - Heatercurrent measurement on board



1 Bediengerät



C **EXTRUSION²**
PACK

2 Steuerungs- und Regeltechnik

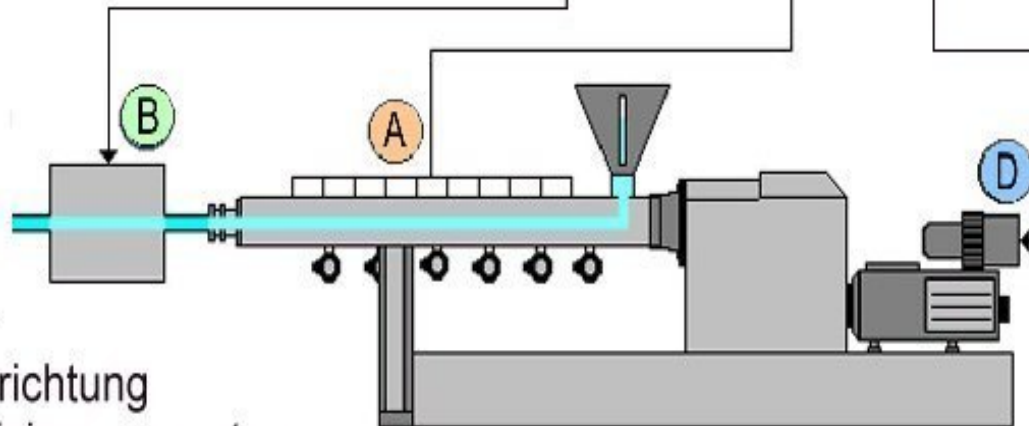

- A - Extruder
- B - Folgeeinrichtung
- C - Automatisierungssystem
- D - Hauptantrieb



ExtrusionPack² Mini

- Max 8 Zones (heat./ cool., autotuning)
- integrated controls
 - maindrive current
 - Meltpressure
 - Srewspeed
- closed loop controll for 1 drive
- monochrome screen
- Recipes (internal flash memory)
- standard FX2N based





ExtrusionPack²

**Basic &
Comfort &
Professional**





C EXTRUSION² PACK

1 Bediengerät



2 Steuerungs- und Regeltechnik

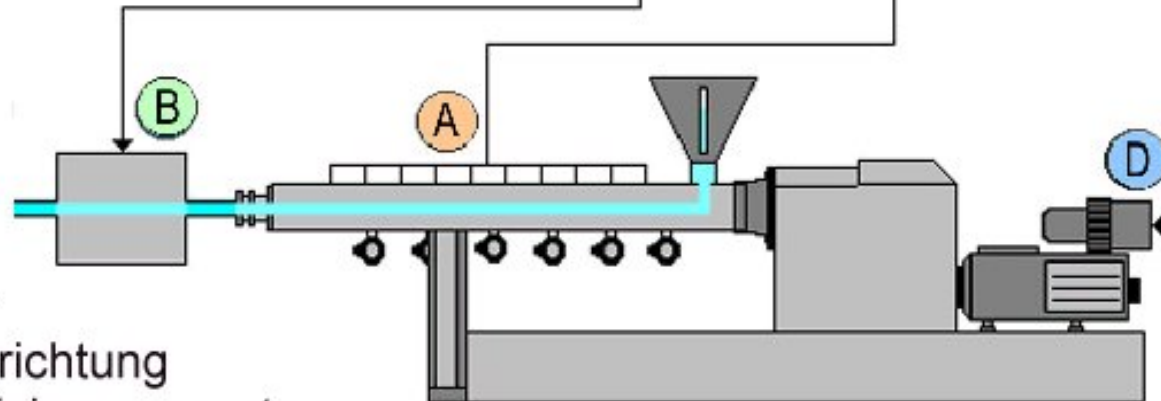

- A - Extruder
- B - Folgeeinrichtung
- C - Automatisierungssystem
- D - Hauptantrieb



ExtrusionPack² Basic

- Max 10 / 20 Zones (heat./ cool., autotuning)
- integrated controls
 - 3 maindrive current
 - 3 Meltpressure
 - 3 Srewspeed
- closed loop controll for 3 drives
- monochrome/color screen
- Touch screen and key's
- Recipes (internal flash memory or floppy)
- optional handy operation
- standard FX2N based





ExtrusionPack² Comfort

- Max 10 / 20 / 30 Zones (heat./ cool., autotuning)
- integrated controlls
 - 2 - 4 Drive current
 - 2 - 4 Pressure
 - 2 - 4 Drivesspeed
- closed loop controll for 2 -4 drives
- VGA/TFT color screen
- Touch screen and key's
- Recipes (internal flash memory or floppy)
- optional integrated driver for dosing
- optional handy operation
- standard FX2N based





ExtrusionPack² Professional

- Max 70 Zones (heat./ cool., autotuning)
- integrated controls
 - max. 10 Drive current
 - max. 10 Pressure
 - max. 10 Drivesspeed
- max. 10 closed loop controls
- VGA/TFT color screen
- Touch screen and key's
- Recipes (internal flash memory or floppy)
- optional integrated driver for dosing
- optional handy operation
- standard AnSH/QnAS

