

Numerical Control (CNC)

Specifications Manual (Hardware)
M800V/M80V Series

Introduction

This manual describes the specifications of Mitsubishi Electric CNC.

Read this manual thoroughly and understand the product's functions and performance before use.

Supported models of this manual are as follows:

Supported models	Abbreviations in this manual
M800VW Series	M850VW, M830VW
M800VS Series	M850VS, M830VS
M80VW Series	M80VW
M80V Series	M80V TypeA, M80V TypeB

Abbreviations for model names used in this manual are as follows:

Abbreviations	Supported models
M800V, M800V Series	M800VW Series/M800VS Series
M80V, M80V Series	M80VW Series/M80V Series
M800V/M80V, M800V/M80V Series	M800VW Series/M800VS Series/M80VW Series/M80V Series
M8V, M8V Series	M800VW Series/M800VS Series/M80VW Series/M80V Series

To safely use this CNC unit, thoroughly study the "Precautions for Safety" before use.

Be sure to keep this manual on hand so that users can refer to it at any time.

Also refer to the manuals on "Manual List" as necessary.

■ Notes on reading this manual

(1) The characteristic values and numerical values without tolerances mentioned in this manual are representative values.

■ Details described in this manual

♦ In this manual, the following abbreviations might be used.

L system: Lathe system

M system: Machining center system

Manual List

Manuals related to M800V/M80V Series are listed as follows.

These manuals are written on the assumption that all optional functions are added to the targeted model.

Some functions or screens may not be available depending on the machine or specifications set by MTB. (Confirm the specifications before use.)

The manuals issued by MTB take precedence over these manuals.

Manual	IB No.	Purpose and Contents
M800V/M80V Series Instruction Manual	IB-1501618	<ul style="list-style-type: none"> ♦ Operation guide for NC ♦ Explanation for screen operation, etc.
M800V/M80V Series Programming Manual (Lathe System) (1/2)	IB-1501619	<ul style="list-style-type: none"> ♦ G code programming for lathe system ♦ Basic functions, etc.
M800V/M80V Series Programming Manual (Lathe System) (2/2)	IB-1501620	<ul style="list-style-type: none"> ♦ G code programming for lathe system ♦ Functions for multi-part system, high-accuracy function, etc.
M800V/M80V Series Programming Manual (Machining Center System) (1/2)	IB-1501621	<ul style="list-style-type: none"> ♦ G code programming for machining center system ♦ Basic functions, etc.
M800V/M80V Series Programming Manual (Machining Center System) (2/2)	IB-1501622	<ul style="list-style-type: none"> ♦ G code programming for machining center system ♦ Functions for multi-part system, high-accuracy function, etc.
M800V/M80V Series Alarm/Parameter Manual	IB-1501623	<ul style="list-style-type: none"> ♦ Alarms ♦ Parameters

Manuals for MTBs (NC)

Manual	IB No.	Purpose and Contents
M800V/M80V Series Specifications Manual (Function)	IB-1501610	<ul style="list-style-type: none"> ♦ Model selection ♦ Outline of various functions
M800V/M80V Series Specifications Manual (Hardware)	IB-1501611	<ul style="list-style-type: none"> ♦ Model selection ♦ Specifications of hardware unit
M800VW/M80VW Series Connection and Setup Manual	IB-1501612	<ul style="list-style-type: none"> ♦ Detailed specifications of hardware unit ♦ Installation, connection, wiring, setup (startup/adjustment)
M800VS/M80V Series Connection and Setup Manual	IB-1501613	<ul style="list-style-type: none"> ♦ Detailed specifications of hardware unit ♦ Installation, connection, wiring, setup (startup/adjustment)
M800V/M80V Series PLC Development Manual	IB-1501614	<ul style="list-style-type: none"> ♦ Electrical design ♦ I/O relation (assignment, setting, connection), field network ♦ Development environment (PLC on-board, peripheral development environment), etc.
M800V/M80V Series PLC Programming Manual (1/2)	IB-1501667	<ul style="list-style-type: none"> ♦ Electrical design ♦ Sequence programming ♦ Explanation for instructions, functions, and parameters
M800V/M80V Series PLC Programming Manual (2/2)	IB-1501668	<ul style="list-style-type: none"> ♦ Electrical design ♦ Sequence programming ♦ Usage examples of instructions
M800V/M80V Series PLC Interface Manual	IB-1501616	<ul style="list-style-type: none"> ♦ Electrical design ♦ Interface signals between NC and PLC
M800V/M80V Series Maintenance Manual	IB-1501617	<ul style="list-style-type: none"> ♦ Cleaning and replacement for each unit ♦ Other items related to maintenance

Manuals for MTBs (drive section)

Manual	IB No.	Contents
MDS-E/EH Series Specifications Manual	IB-1501226	<ul style="list-style-type: none"> ♦ Specifications for power supply regeneration type
MDS-E/EH Series Instruction Manual	IB-1501229	<ul style="list-style-type: none"> ♦ Instruction for power supply regeneration type
MDS-EJ/EJH Series Specifications Manual	IB-1501232	<ul style="list-style-type: none"> ♦ Specifications for regenerative resistor type
MDS-EJ/EJH Series Instruction Manual	IB-1501235	<ul style="list-style-type: none"> ♦ Instruction for regenerative resistor type
MDS-EM/EMH Series Specifications Manual	IB-1501238	<ul style="list-style-type: none"> ♦ Specifications for multi-hybrid, power supply regeneration type
MDS-EM/EMH Series Instruction Manual	IB-1501241	<ul style="list-style-type: none"> ♦ Instruction for multi-hybrid, power supply regeneration type
DATA BOOK	IB-1501252	<ul style="list-style-type: none"> ♦ Specifications of servo drive unit, spindle drive unit, motor, etc.
MDS-EX-CVP Series Specifications and Instruction Manual	IB-1501587	<ul style="list-style-type: none"> ♦ Specifications and instruction for the power supply unit with large capacity

Manuals for MTBs (Others)

Manual	No.	Purpose and Contents
GOT2000 Series User's Manual (Hardware)	SH-081194ENG	♦ Outline of hardware such as part names, external dimensions, installation, wiring, maintenance, etc. of GOTs
GOT2000 Series User's Manual (Utility)	SH-081195ENG	♦ Outline of utilities such as screen display setting, operation method, etc. of GOTs
GOT2000 Series User's Manual (Monitor)	SH-081196ENG	♦ Outline of each monitor function of GOTs
GOT2000 Series Connection Manual (Mitsubishi Electric Products)	SH-081197ENG	♦ Outline of connection types and connection method between GOT and Mitsubishi Electric connection devices
GT Designer3 (GOT2000) Screen Design Manual	SH-081220ENG	♦ Outline of screen design method using screen creation software GT Designer3
GOT2000/GOT1000 Series CC-Link Communication Unit User's Manual	IB-0800351	♦ Explanation for handling CC-Link communication unit (for GOT2000 series/GOT1000 series)
GX Developer Version 8 Operating Manual (Startup)	SH-080372E	♦ Explanation for system configuration, installation, etc. of PLC development tool GX Developer
GX Developer Version 8 Operating Manual	SH-080373E	♦ Explanation for operations using PLC development tool GX Developer
GX Converter Version 1 Operating Manual	IB-0800004	♦ Explanation for operations using data conversion tool GX Converter
GX Works2 Installation Instructions	BCN-P5999-0944	♦ Explanation for the operating environment and installation method of GX Works2
GX Works2 Version 1 Operating Manual (Common)	SH-080779ENG	♦ Explanation for the system configuration of GX Works2 and the functions common to Simple project and Structured project such as parameter setting, operation method for the online function
GX Works2 Version 1 Operating Manual (Simple Project)	SH-080780ENG	♦ Explanation for methods for such as creating and monitoring programs in Simple project of GX Works2
MELSEC-Q/L/F Structured Programming Manual (Fundamentals)	SH-080782ENG	♦ Explanation for programming methods, types of programming languages, etc. required to create structured programs
MELSEC-Q/L Structured Programming Manual (Application Functions)	SH-080784ENG	♦ Explanation for specifications and functions related to application functions which can be used in structured programs
GX Works2 Version 1 Operating Manual (Simple Project, Function Block)	SH-080984ENG	♦ Explanation for methods for such as creating function blocks, pasting function blocks to sequence programs, and operating FB library in Simple project of GX Works2
GX Works2 Version 1 Operating Manual (Structured Project)	SH-080781ENG	♦ Explanation for methods for such as creating and monitoring programs in Structured project of GX Works2
GX Works3 Installation Instructions	BCN-P5999-0391	♦ Explanation for the operating environment and installation method of GX Works3
MELSEC-Q CC-Link System Master/Local Module User's Manual	SH-080394E	♦ Explanation for system configuration, installation, wiring, etc. of master/local modules for CC-Link system
GOT2000 Series Connection Manual (Non-Mitsubishi Electric Products 1)	SH-081198ENG	♦ Explanation for connection types and connection method between GOT and other company's devices
GOT2000 Series Connection Manual (Non-Mitsubishi Electric Products 2)	SH-081199ENG	
GOT2000 Series Connection Manual (Microcomputers, MODBUS/Fieldbus Products, Peripherals)	SH-081200ENG	♦ Explanation for connection types and connection method between GOT and microcomputers, MODBUS/fieldbus products, peripherals
GT SoftGOT2000 Version1 Operating Manual	SH-081201ENG	♦ Explanation for system configuration, screen configuration and operation method of monitoring software GT SoftGOT2000
MELSEC iQ-R Programming Manual (CPU Module Instructions, Standard Functions/Function Blocks)	SH-081266ENG	♦ Explanation for instructions, general-purpose functions, and general-purpose function blocks required for programming the sequencer MELSEC iQ-R series



Reference Manual for MTBs

Manual	No.	Purpose and Contents
M800/M80 Series Smart safety observation Specification manual	BNP-C3072-022	♦ Explanation for smart safety observation function
M800/M80 Series CC-Link (Master/Local) Specification manual	BNP-C3072-089	♦ Explanation for CC-Link
M800/M80 Series PROFIBUS-DP Specification manual	BNP-C3072-118	♦ Explanation for PROFIBUS-DP communication function
M800/M80 Series Interactive cycle insertion (Customization) Specification manual	BNP-C3072-121-0003	♦ Explanation for interactive cycle insertion
M800/M80 Series EtherNet/IP Specifications manual	BNP-C3072-263	♦ Explanation for EtherNet/IP
M800/M80 Series CC-Link IE Field (Master/local) Specifications manual	BNP-C3072-283	♦ Explanation for CC-Link IE Field
M800/M80 Series GOT Connection Specifications manual	BNP-C3072-314	♦ Explanation for GOT connection
M800/M80 Series CC-Link IE Field Basic Specifications manual	BNP-C3072-337	♦ Explanation for CC-Link IE Field Basic
M800/M80 Series FL-net Specifications manual	BNP-C3072-368	♦ Explanation for FL-net
M800/M80 Series Synchronous Control Specifications manual	BNP-C3072-074	♦ Explanation for synchronous control
M800/M80 Series Multiple-Axis Synchronization Control Specifications manual	BNP-C3072-339	♦ Explanation for multiple-axis synchronization control

Precautions for Safety



Always read this manual, related manuals and attached documents before installation, operation, programming, maintenance or inspection to ensure correct use. Understand all the conditions described in this manual before using the unit.



We rank the safety precautions into "DANGER", "WARNING" and "CAUTION" for the manuals issued by Mitsubishi Electric, including this manual.

 DANGER When the user may be subject to imminent fatalities or major injuries if handling is mistaken.
 WARNING When the user may be subject to fatalities or major injuries if handling is mistaken.
 CAUTION When the user may be subject to medium or minor injuries or when only property damage may occur, if handling is mistaken.











Note that even items ranked as " ⚠ CAUTION", may lead to serious consequences depending on the situation. All the items are important and must always be observed.

The following signs indicate prohibition and compulsory.

	This sign indicates prohibited behavior (must not do). For example,  indicates "Keep fire away".
------------------------------------------------------------------------------------	---------------------------------------------------------------------------------------------------------------------------------------------------------------------------------------

	This sign indicated a thing that is compulsory (must do). For example,  indicates "it must be grounded".
-------------------------------------------------------------------------------------	------------------------------------------------------------------------------------------------------------------------------------------------------------------------------------------------

The meaning of each pictorial sign is as follows.

 CAUTION	 CAUTION rotated object	 CAUTION HOT	 Danger Electric shock risk	 Danger explosive
 Prohibited	 Disassembly is prohibited	 KEEP FIRE AWAY	 General instruction	 Earth ground

For Safe Use

Mitsubishi Electric CNC is designed and manufactured solely for applications to machine tools to be used for industrial purposes.

Do not use this product in any applications other than those specified above, especially those which are substantially influential on the public interest or which are expected to have significant influence on human lives or properties.

⚠ DANGER

Not applicable in this manual.

⚠ WARNING

Not applicable in this manual.

⚠ CAUTION

■ **Items related to product and manual**

- ⚠ The items that are not described in this manual must be interpreted as "not possible".
- ⚠ This manual is written on the assumption that all the applicable functions are included. Some of them, however, may not be available for your NC system. Refer to the specifications issued by the machine tool builder before use.
- ⚠ Some screens and functions may differ depending on each NC system (or version), and some functions may not be possible. Please confirm the specifications before starting to use.
- ⚠ To protect the availability, integrity and confidentiality of the NC system against cyber-attacks including unauthorized access, denial-of-service (Dos) (*1) attack, and computer virus from external sources via a network, take security measures such as firewall, VPN, and anti-virus software.
- ⚠ Mitsubishi Electric assumes no responsibility for any problems caused to the NC system by any type of cyber-attacks including DoS attack, unauthorized access and computer virus.

(*1) Denial-of-service (Dos) refers to a type of cyber-attack that disrupts services by overloading the system or by exploiting a vulnerability of the system.

■ **Items related to start up and maintenance**

- ⚠ Follow the power specifications (input voltage range, frequency range, momentary power failure time range) described in this manual.
- ⚠ Follow the environment conditions (ambient temperature, humidity, vibration, atmosphere) described in this manual.
- ❗ Follow the remote type machine contact input/output interface described in this manual. (Connect a diode in parallel with the inductive load or connect a protective resistor in serial with the capacitive load, etc.)
- ⚠ If the temperature rise detection function is invalidated with the parameters, the control could be disabled when the temperature is excessive. This could result in machine damage or personal injuries due to runaway axis, and could damage the device. Enable the detection function for normal use. The parameter for the temperature rise detection function will be validated forcibly when the NC unit is turned ON.

Treatment of waste

The following two laws will apply when disposing of this product. Considerations must be made to each law. The following laws are in effect in Japan. Thus, when using this product overseas, the local laws will have a priority. If necessary, indicate or notify these laws to the final user of the product.

- (1) Requirements for "Law for Promotion of Effective Utilization of Resources"
 - (a) Recycle as much of this product as possible when finished with use.
 - (b) When recycling, often parts are sorted into steel scraps and electric parts, etc., and sold to scrap contractors. Mitsubishi Electric recommends sorting the product and selling the members to appropriate contractors.

- (2) Requirements for "Law for Treatment of Waste and Cleaning"
 - (a) Mitsubishi Electric recommends recycling and selling the product when no longer needed according to item (1) above. The user should make an effort to reduce waste in this manner.
 - (b) When disposing a product that cannot be resold, it shall be treated as a waste product.
 - (c) The treatment of industrial waste must be commissioned to a licensed industrial waste treatment contractor, and appropriate measures, including a manifest control, must be taken.
 - (d) Batteries correspond to "primary batteries", and must be disposed of according to local disposal laws.

Disposal



(Note) This symbol mark is for EU countries only.
This symbol mark is according to the directive 2006/66/EC Article 20 Information for end-users and Annex II.

Your MITSUBISHI ELECTRIC product is designed and manufactured with high quality materials and components which can be recycled and/or reused.

This symbol means that batteries and accumulators, at their end-of-life, should be disposed of separately from your household waste.

If a chemical symbol is printed beneath the symbol shown above, this chemical symbol means that the battery or accumulator contains a heavy metal at a certain concentration. This will be indicated as follows:

Hg: mercury (0.0005%), Cd: cadmium (0.002%), Pb: lead (0.004%)

In the European Union there are separate collection systems for used batteries and accumulators.

Please, dispose of batteries and accumulators correctly at your local community waste collection/recycling centre.

Please, help us to conserve the environment we live in!

Trademarks

MELDAS, MELSEC, EZSocket, EZMotion, iQ Platform, MELSEC iQ-R, MELSOFT, GOT, CC-Link, CC-Link/LT, CC-Link IE, CC-Link IE/field, EcoMonitorLight and SLMP are either trademarks or registered trademarks of Mitsubishi Electric Corporation in Japan and/or other countries.

Ethernet is a registered trademark of Xerox Corporation in the United States and/or other countries.

Microsoft®, Windows®, SQL Server® and Access® are either trademarks or registered trademarks of Microsoft Corporation in the United States and/or other countries.

SD logo and SDHC logo are either registered trademarks or trademarks of LLC.

UNIX is a registered trademark of The Open Group in the United States and/or other countries.

Intel® and Pentium® are either trademarks or registered trademarks of Intel Corporation in the United States and/or other countries.

MODBUS® is either a trademark or a registered trademark of Schneider Electric USA, Inc. or the affiliated companies in Japan and/or other countries.

EtherNet/IP is a trademark of Open DeviceNet Vendor Association, Inc.

PROFIBUS-DP is either a trademark or a registered trademark of PROFIBUS User Organization.

Oracle® is a registered trademark of Oracle Corporation, the subsidiaries, or the affiliated companies in the United States and /or other countries.

VNC is a registered trademark of RealVNC Ltd. in the United States and other countries.

QR Code is a registered trademark of DENSO WAVE INCORPORATED.

TRELLIX is a registered trademark or a trademark of Musarubra US LLC or its subsidiaries in the United States and other countries.

Punchtap is licensed by EMUGE.

The term HDMI and the HDMI Logo are trademarks or registered trademarks of HDMI Licensing Administrator, Inc. in the United States and other countries.

Wi-Fi is either a trademark or a registered trademark of Wi-Fi Alliance.

BiSS is a registered trademark of iC-Haus GmbH.

Other company and product names that appear in this manual are trademarks or registered trademarks of the respective companies.

本製品の取扱いについて

(日本語 /Japanese)

本製品は工業用 (クラス A) 電磁環境適合機器です。販売者あるいは使用者はこの点に注意し、住商業環境以外での使用をお願いいたします。

Handling of our product

(English)

This is a class A product. In a domestic environment this product may cause radio interference in which case the user may be required to take adequate measures.

본 제품의 취급에 대해서

(한국어 /Korean)

이 기기는 업무용 (A 급) 전자파적합기기로서 판매자 또는 사용자는 이 점을 주의하시기 바라며 가정외의 지역에서 사용하는 것을 목적으로 합니다 .

WARRANTY

Please confirm the following product warranty details before using Mitsubishi Electric CNC.

1. Warranty Period and Coverage

Should any fault or defect (hereafter called "failure") for which we are liable occur in this product during the warranty period, repair services shall be provided at no cost through the distributor from which the product was purchased or through a Mitsubishi Electric service provider. Note, however, that this does not apply if the customer was informed prior to purchasing the product that the product is not covered under warranty. Also note that we are not responsible for any on-site readjustment and/or trial run that may be required after a defective unit is replaced.

[Warranty Term]

The term of warranty for this product shall be twenty-four (24) months from the date of delivery of the product to the end user, provided the product purchased from Mitsubishi Electric or a distributor in Japan is installed in Japan (but in no event longer than thirty (30) months, including distribution time after shipment from Mitsubishi Electric or a distributor).

Note that, in the case where the product purchased from Mitsubishi Electric or a distributor in or outside Japan is exported and installed in any country other than where it was purchased, please refer to "2. Service in Overseas Countries" below.

[Limitations]

- (1) The machine tool builder is requested to conduct an initial failure diagnosis, as a general rule. The diagnosis may also be carried out by Mitsubishi Electric or our service provider for a fee at the machine tool builder's request.
- (2) This warranty applies only when the conditions, method, environment, etc., of use are in compliance with the terms, conditions and instructions that are set forth in the instruction manual, user's manual, and the caution label affixed to the product, etc.
- (3) Even during the term of warranty, repair costs will be charged to the customer in the following cases:
 - (a) a failure caused by improper storage or handling, carelessness or negligence, etc., or a failure caused by a problem with the customer's hardware or software
 - (b) a failure caused by any alteration, etc., to the product made by the customer without Mitsubishi Electric's approval
 - (c) a failure which may be regarded as avoidable, if the customer's equipment in which this product is incorporated is equipped with a safety device required by applicable laws or has any function or structure considered to be indispensable in the light of common sense in the industry
 - (d) a failure which could have been avoided if consumable parts designated in the instruction manual, etc. had been duly maintained and replaced
 - (e) any replacement of consumable parts (including the battery, relay and fuse)
 - (f) a failure caused by external factors such as inevitable accidents, including without limitation fire and abnormal fluctuation of voltage, and acts of God, including without limitation earthquakes, lightning, and natural disasters
 - (g) a failure which could not have been foreseen under technologies available at the time of shipment of this product from Mitsubishi Electric
 - (h) any other failures which are not attributable to Mitsubishi Electric or which the customer acknowledges are not attributable to Mitsubishi Electric

2. Service in Overseas Countries

If the customer installs a product purchased from Mitsubishi Electric in a machine or equipment and exports it to any country other than where it was purchased, the customer may sign a paid warranty contract with our local FA center.

This applies in the case where the product purchased from us in or outside Japan is exported and installed in any country other than where it was purchased.

For details please contact the distributor from which the product was purchased.

3. Exclusion of Responsibility for Compensation against Loss of Opportunity, Secondary Loss, etc.

Regardless of the gratis warranty term, Mitsubishi Electric shall not be liable for compensation for:

- (1) Damage arising from any cause found not to be the responsibility of Mitsubishi Electric.
- (2) Lost opportunity or lost profit incurred by the user due to a failure of a Mitsubishi Electric product.
- (3) Special damage or secondary damage, whether foreseeable or not, compensation for accidents, and compensation for damages to products other than Mitsubishi Electric products.
- (4) Replacement by the user, maintenance of on-site equipment, start-up test run and other tasks.

4. Changes in Product Specifications

Specifications shown in our catalogs, manuals or technical documents are subject to change without notice.

5. Product Application

- (1) For use of this product, applications should be those that will not result in a serious damage even if a failure or malfunction occurs in the product, and a backup or failsafe function should operate on an external system when any failure or malfunction occurs to the product.
- (2) Mitsubishi Electric CNC is designed and manufactured solely for applications to machine tools for industrial purposes. Do not use this product in applications other than those specified above, especially those which have substantial influence on public interest or which are expected to have significant influence on human lives or properties.

Contents

M800VW/M80VW Series Hardware	1
1 System Basic Configuration (M800VW/M80VW Series)	3
1.1 System Basic Configuration Drawing.....	4
2 General Connection Diagram (M800VW/M80VW Series)	5
2.1 M800VW Series, Windows-based Display Unit	7
2.2 M80VW Series, Windows-based Display Unit	8
2.3 19-type Display Unit	9
2.4 Connecting a Laser I/F Unit	10
3 List of Configuration (M800VW/M80VW Series)	11
3.1 Control Unit [M800VW]	12
3.2 Control Unit [M80VW]	12
3.3 Display Unit [M800VW]	13
3.4 Display Unit [M80VW]	13
3.5 Personal Computer Unit.....	13
3.6 Keyboard Unit	13
3.7 Operation Panel I/O Unit.....	14
3.8 Remote I/O Unit	15
3.9 Laser I/F Unit.....	15
3.10 Function Expansion Unit.....	16
3.11 Side Memory I/F Unit	16
3.12 Manual Pulse Generator	16
3.13 Synchronous Feed Encoder.....	16
3.14 Machine Operation Panel.....	17
3.15 Handy Terminal.....	17
3.16 Cable Connector Sets	18
3.17 Thermistor Set.....	18
3.18 Genuine Memory Card.....	18
3.19 Durable Parts	18
3.20 Replacements	18
3.21 List of Cables	19
3.22 System Type	20
4 General Specifications (M800VW/M80VW Series)	21
4.1 Environment Conditions [M800VW]	22
4.1.1 Environment Conditions Inside the Operation Panel.....	22
4.1.2 Environment Conditions Inside the Control Panel.....	24
4.1.3 24 VDC Stabilized Power Supply Selecting Conditions	27
4.2 Environment Conditions [M80VW]	28
4.2.1 Environment Conditions Inside the Operation Panel.....	28
4.2.2 Environment Conditions Inside the Control Panel.....	30
4.2.3 24 VDC Stabilized Power Supply Selecting Conditions	33
4.3 Control Unit [M800VW]	34
4.3.1 M830VW(FCU8-MU052)/M850VW(FCU8-MA051).....	34
4.4 Control Unit [M80VW]	36
4.4.1 FCU8-MU054	36
4.5 Display Unit [M800VW]	38
4.5.1 15-type (FCU8-DU182-34).....	38
4.5.2 19-type (FCU8-DU193-75).....	40
4.5.3 19-type (FCU8-DU194-75)	42
4.6 Display Unit [M80VW]	44
4.6.1 15-type (FCU8-DU182-36).....	44
4.6.2 19-type (FCU8-DU193-77).....	46
4.6.3 19-type (FCU8-DU194-77).....	48
4.7 Personal Computer Unit.....	50
4.7.1 Personal Computer Unit (FCU8-PC232).....	50
4.7.2 Built-in Disk of the Display Unit (FCU8-CF060G-1).....	51
4.8 Keyboard Unit	52
4.8.1 Keyboard for 15-type Display Unit (FCU8-KB083).....	52
4.9 Operation Panel I/O Unit.....	53

4.9.1 List of Units	53
4.9.2 FCU8-DX830/FCU8-DX834/FCU8-DX837	54
4.10 Remote I/O Unit	57
4.10.1 List of Units	57
4.10.2 FCU8-DX220/FCU8-DX230/FCU8-DX231/FCU8-DX202/FCU8-DX213/ FCU8-DX213-1/FCU8-DX654/FCU8-DX654-1/FCU8-DX651/FCU8-DX408/FCU8-DX409	58
4.11 Laser I/F Unit	65
4.11.1 FCU8-DX522-001	65
4.12 Function Expansion Unit	66
4.12.1 Encoder (Manual Pulse Generator) I/F Expansion (FCU8-EX544)	66
4.12.2 CC-Link (FCU8-EX561)	67
4.12.3 PROFIBUS-DP (FCU8-EX563)	68
4.12.4 CC-Link IE Field (FCU8-EX564)	69
4.12.5 EtherNet/IP (FCU8-EX565)	70
4.12.6 FL-net (FCU8-EX568)	71
4.12.7 Vibration Cutting Expansion Unit (FCU8-EX744)	72
4.13 Side Memory I/F Unit	73
4.13.1 FCU8-EP201-2	73
4.14 Manual Pulse Generator	75
4.14.1 5 V Manual Pulse Generator (UFO-01-2Z9)	75
4.14.2 12 V Manual Pulse Generator (HD60C)	76
4.15 Synchronous Feed Encoder	77
4.15.1 Synchronous Feed Encoder (OSE-1024-3-15-68)	77
4.16 Machine Operation Panel	79
4.16.1 Main Panels A/B (FCU8-KB921/FCU8-KB922/FCU8-KB925, FCU8-KB923/FCU8-KB924/FCU8-KB926)	79
4.16.2 Sub Panel A (FCU8-KB931/FCU8-KB941)	83
4.17 Handy Terminal	84
4.18 Thermistor	86
4.18.1 Thermistor(PT3C-51F-M2)	86
4.19 Exclusive SD Cards	87
4.20 Specifications and Precautions of USB/SD/LAN Interface	88
4.20.1 USB Interface (Personal Computer Unit, Side Memory I/F Unit)	88
4.20.2 SD Interface (Control Unit, Side Memory I/F Unit)	89
4.20.3 LAN Interface (Control Unit, Personal Computer Unit)	89

M800VS/M80V Series Hardware	91
1 System Basic Configuration (M800VS/M80V Series).....	93
1.1 System Basic Configuration Drawing.....	94
2 General Connection Diagram (M800VS/M80V Series)	95
2.1 M800VS Series	97
2.2 M80V Series.....	98
2.3 19-type Display Unit.....	99
2.4 Connecting an Operation Panel I/O Unit (FCU8-DX834).....	100
2.5 Connecting a Pulse-controlled Inverter (M80V Series)	101
2.6 Connecting a BiSS Encoder.....	102
2.7 Connecting an Image Input Expansion Unit.....	103
2.8 Connecting a Laser I/F Unit	104
2.9 Connecting an EcoMonitorLight	104
3 List of Configuration (M800VS/M80V Series)	105
3.1 Control Unit [M800VS]	106
3.2 Control Unit [M80V].....	106
3.3 Display Unit [M800VS]	106
3.4 Display Unit [M80V].....	107
3.5 Keyboard Unit [M800VS].....	108
3.6 Keyboard Unit [M80V]	108
3.7 Operation Panel I/O Unit.....	109
3.8 Remote I/O Unit	110
3.9 Laser I/F Unit.....	110
3.10 Functional Safety Expansion Unit [M80V].....	111
3.11 Function Expansion Unit	111
3.12 Manual Pulse Generator	111
3.13 Synchronous feed encoder	111
3.14 Machine Operation Panel.....	112
3.15 Handy Terminal.....	112
3.16 Cable Connector Sets	113
3.17 Thermistor Set.....	113
3.18 Genuine Memory Card.....	113
3.19 Durable Parts	113
3.20 Replacements	113
3.21 List of Cables	114
3.22 System Type	116
4 General Specifications (M800VS/M80V Series).....	117
4.1 Environment Conditions [M800VS]	118
4.1.1 Installation Environment Conditions	118
4.1.2 24 VDC Stabilized Power Supply Selecting Conditions	122
4.2 Environment Conditions [M80V].....	123
4.2.1 Installation Environment Conditions	123
4.2.2 24 VDC Stabilized Power Supply Selecting Conditions	127
4.3 Control Unit [M800VS]	128
4.3.1 FCU8-MU551 / FCU8-MA551	128
4.4 Control Unit [M80V].....	129
4.4.1 FCU8-MU521 / FCU8-MU522	129
4.5 Display Unit [M800VS]	130
4.5.1 10.4-type (FCU8-DU142-31)	130
4.5.2 15-type (FCU8-DU182-31)	131
4.5.3 19-type (FCU8-DU194-31)	133
4.6 Display Unit [M80V].....	135
4.6.1 8.4-type (FCU8-DU122-12)	135
4.6.2 10.4-type (FCU8-DU142-32)	136
4.6.3 15-type (FCU8-DU182-32)	137
4.6.4 19-type (FCU8-DU194-32)	139
4.7 Keyboard Unit	141
4.7.1 Keyboard for 8.4-type Display Unit (FCU8-KB026).....	142
4.7.2 Keyboard for 8.4-type Display Unit (FCU8-KB028).....	143
4.7.3 Keyboard for 8.4-type Display Unit (FCU8-KB029).....	144
4.7.4 Keyboard for 10.4-type Display Unit (FCU8-KB041).....	145

4.7.5 Keyboard for 10.4-type Display Unit (FCU8-KB046)	146
4.7.6 Keyboard for 10.4-type Display Unit (FCU8-KB047)	147
4.7.7 Keyboard for 10.4-type Display Unit (FCU8-KB048)	148
4.7.8 Keyboard for 15-type Display Unit (FCU8-KB083)	149
4.7.9 Keyboard for 19-type Display Unit (FCU8-KB091)	150
4.8 Operation Panel I/O Unit	151
4.8.1 List of Units	151
4.8.2 FCU8-DX731/FCU8-DX750/FCU8-DX760/FCU8-DX761/FCU8-DX834	152
4.9 Remote I/O Unit	156
4.9.1 List of Units	156
4.9.2 FCU8-DX220/FCU8-DX230/FCU8-DX231/FCU8-DX202/FCU8-DX213/ FCU8-DX213-1/FCU8-DX654/FCU8-DX654-1/FCU8-DX651/FCU8-DX408/FCU8-DX409	157
4.10 Laser I/F Unit	164
4.10.1 FCU8-DX522-001	164
4.11 Functional Safety Expansion Unit	165
4.11.1 Functional Safety Expansion Unit (FCU8-EX134)	165
4.12 Function Expansion Unit	166
4.12.1 CC-Link (FCU8-EX561)	166
4.12.2 PROFIBUS-DP (FCU8-EX563)	167
4.12.3 CC-Link IE Field (FCU8-EX564)	168
4.12.4 EtherNet/IP (FCU8-EX565)	169
4.12.5 FL-net (FCU8-EX568)	170
4.12.6 Vibration Cutting Expansion Unit (FCU8-EX744)	171
4.12.7 Image Input Expansion Unit (FCU8-EX752)	172
4.12.8 Option Relay Unit (FCU8-EX704)	173
4.12.9 Option Relay Unit (FCU8-EX705)	174
4.13 Manual Pulse Generator	175
4.13.1 5 V Manual Pulse Generator (UFO-01-2Z9)	175
4.13.2 12 V Manual Pulse Generator (HD60C)	176
4.14 Synchronous Feed Encoder	177
4.14.1 Synchronous Feed Encoder (OSE-1024-3-15-68)	177
4.15 Machine Operation Panel	179
4.15.1 Main Panels A/B (FCU8-KB921/FCU8-KB922/FCU8-KB925, FCU8-KB923/FCU8-KB924/FCU8-KB926)	179
4.15.2 Sub Panel A (FCU8-KB931/FCU8-KB941)	183
4.16 Handy Terminal	184
4.17 Thermistor	186
4.17.1 Thermistor(PT3C-51F-M2)	186
4.18 Exclusive SD Cards	187
4.19 Specifications and Precautions of USB/SD/LAN/Wireless LAN/HDMI Interface	188
4.19.1 USB Interface (Memory I/F card)	188
4.19.2 USB Interface (Image Input Expansion Unit)	188
4.19.3 SD Interface (Memory I/F card)	189
4.19.4 LAN Interface (Control Unit)	189
4.19.5 Wireless LAN Interface (Control Unit)	190
4.19.6 HDMI Interface (Image Input Expansion Unit)	190

M800VW/M80VW Series Hardware



System Basic Configuration (M800VW/M80VW Series)

1.1 System Basic Configuration Drawing

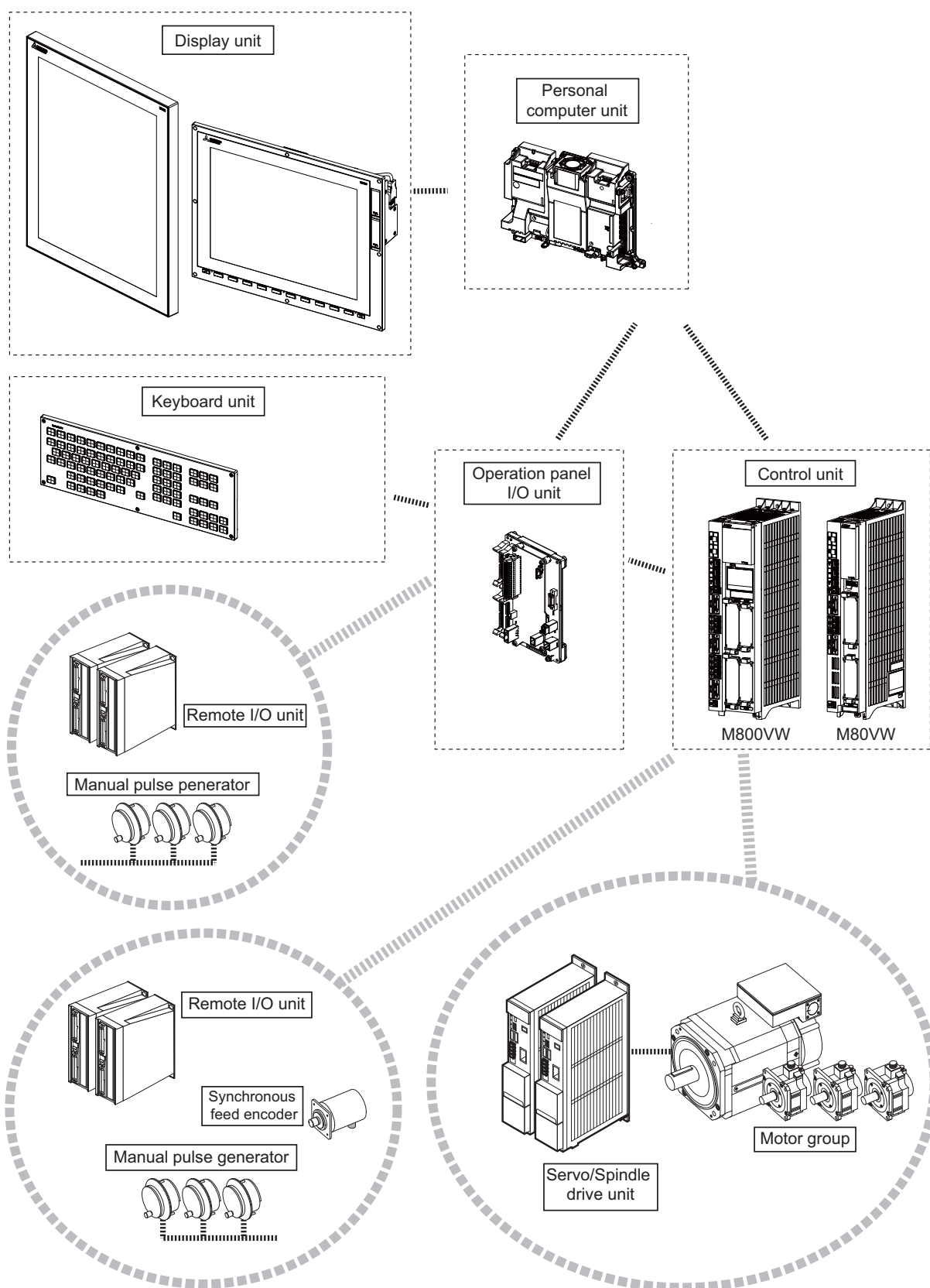

Note

(1) For the drive unit configuration, refer to the instruction manual of the drive unit you use.

**General Connection Diagram
(M800VW/M80VW Series)**

Typical general connection diagrams for respective models are described.

Refer to the following chapters for parts where the connection differs depending on the unit configuration.

2.3 19-type Display Unit

2.4 Connecting a Laser I/F Unit

2.1 M800VW Series, Windows-based Display Unit

⋯ Dotted lines indicate the sections prepared by the machine tool builder.

<> Angle brackets indicates attached cable of unit.

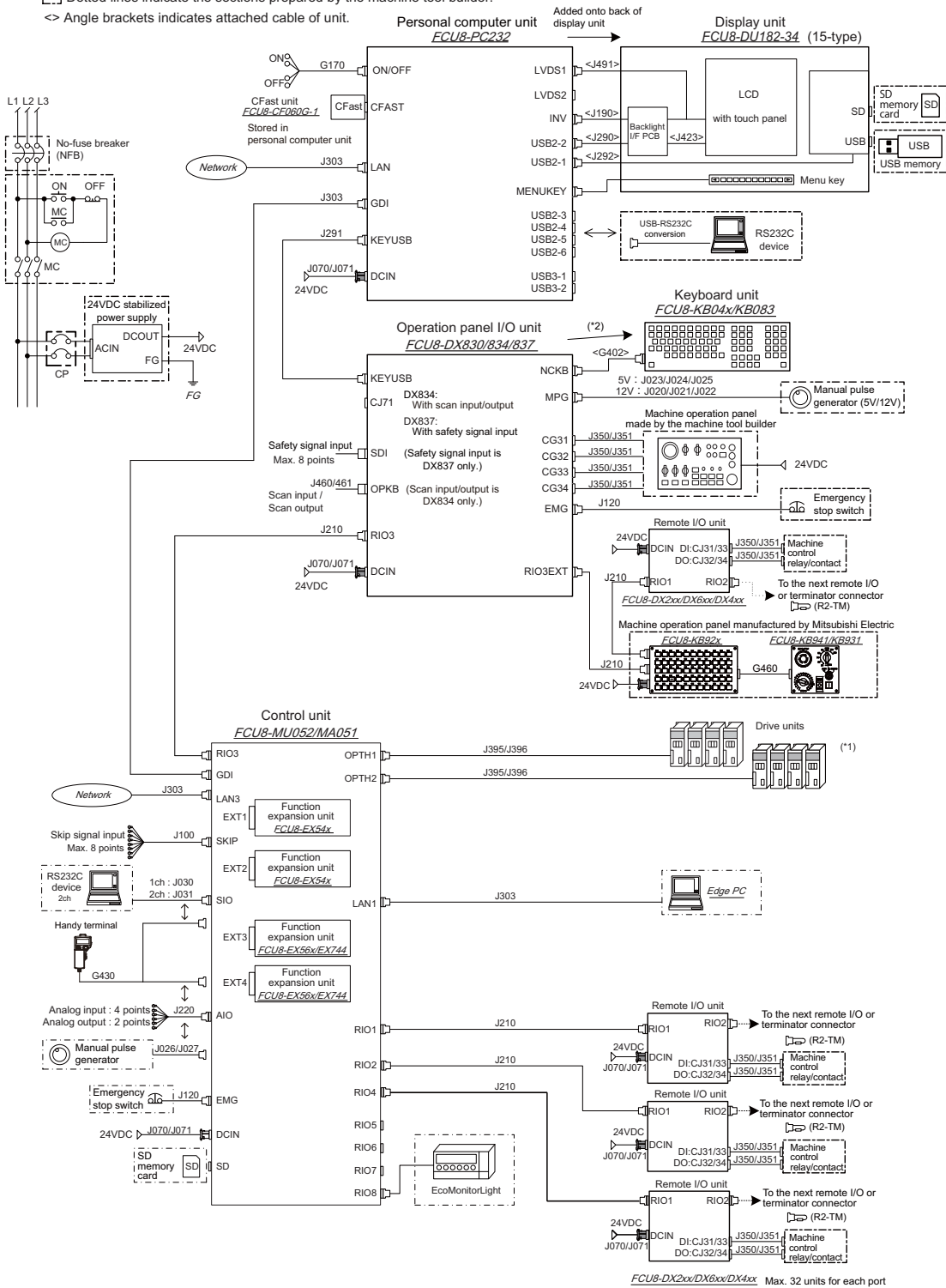

(*1) For information on how to connect the drive unit, refer to the drive unit's manual.

(*2) When using a keyboard unit, install the operation panel I/O unit on the back of the keyboard unit.

2.3 19-type Display Unit

Dotted lines indicate the sections which is different from the 15-type display unit in the 19-type display unit.

19-type display unit

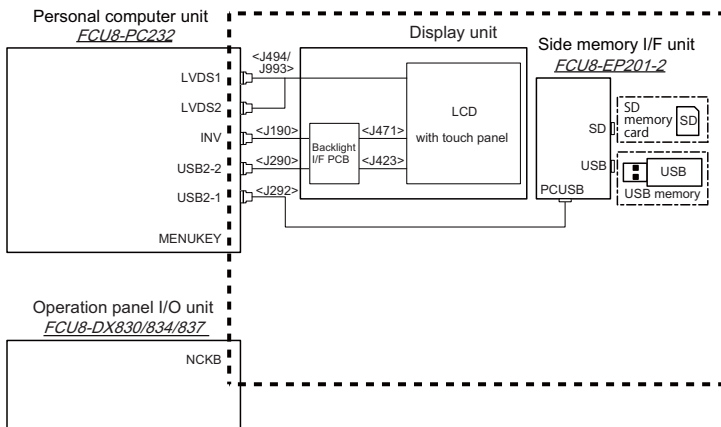

- The personal computer unit is installed on the back of the display unit.

Display unit for M800VW Series	Display unit for M80VW Series
FCU8-DU193-75	FCU8-DU193-77
FCU8-DU194-75	FCU8-DU194-77

15-type display unit

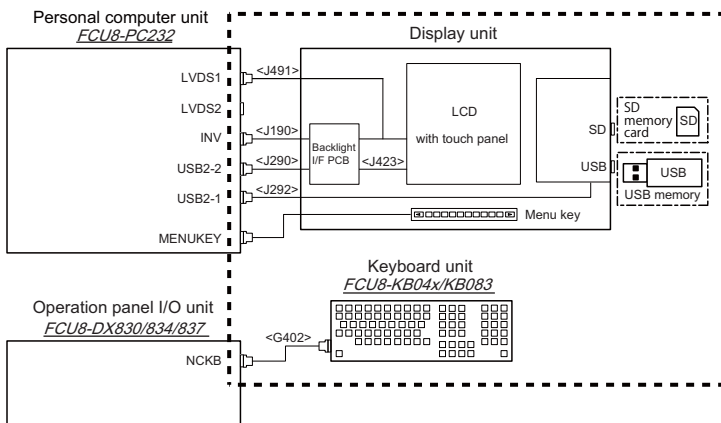

- The personal computer unit is installed on the back of the display unit.
- The operation board I/O unit is installed on the back of the keyboard unit.

Display unit for M800VW Series	Display unit for M80VW Series
FCU8-DU182-34	FCU8-DU182-36

2.4 Connecting a Laser I/F Unit

Connect the laser I/F unit to any of RIO1, RIO2 and RIO4 of the control unit.
 The following figure shows an example of connecting the laser I/F unit to RIO2.

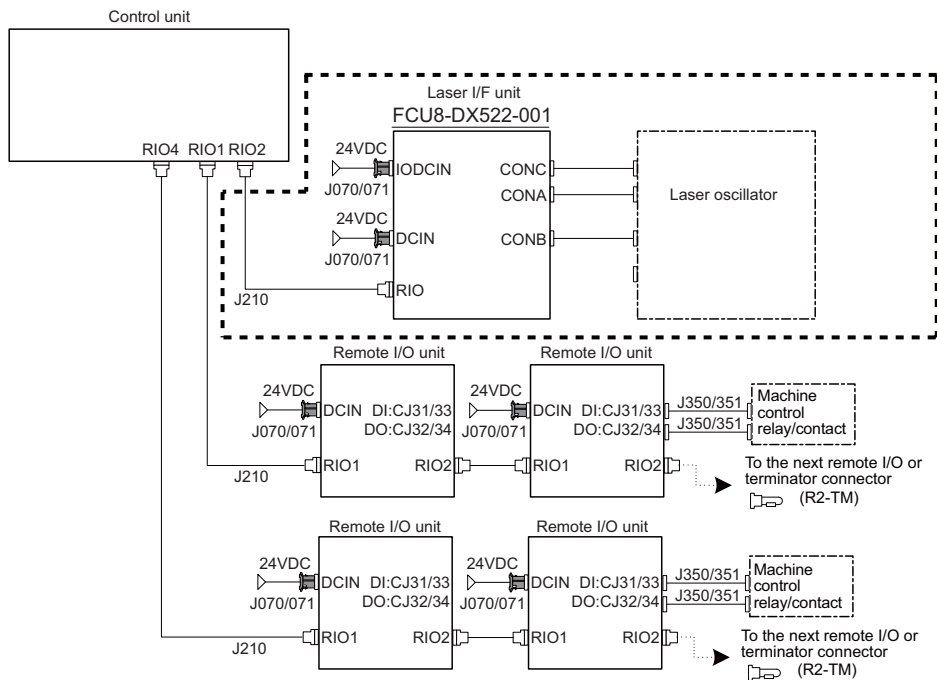

Note

- (1) The laser I/F unit occupies all one channel; therefore, a remote I/O unit cannot be connected before or after the laser I/F unit.

List of Configuration (M800VW/M80VW Series)

3 List of Configuration (M800VW/M80VW Series)

3.1 Control Unit [M800VW]

Classification	Type	Components	Remark
NC function For M830VW	FCU8-MU052	Main CPU card 7SEG card SDHC: 1ch Back panel card Unit lid (Resin molded article) etc.	This unit is not compliant with either the Export Trade Control Order or Foreign Exchange Order. G123 cable for EMG is attached.
NC function For M850VW	FCU8-MA051	Main CPU card 7SEG card SDHC: 1ch Back panel card Unit lid (Resin molded article) etc.	This unit is compliant with the Foreign Exchange Order but not with the Export Trade Control Order. G123 cable for EMG is attached.

3.2 Control Unit [M80VW]

Classification	Type	Components	Remark
NC function For M80VW	FCU8-MU054	Main CPU card 7SEG card SDHC: 1ch Back panel card Unit lid (Resin molded article) etc.	This unit is not compliant with either the Export Trade Control Order or Foreign Exchange Order. G123 cable for EMG is attached.

3.3 Display Unit [M800VW]

Classification	Type	Components	Remark
15-type color LCD touchscreen (XGA:1024 x 768)	FCU8-DU182-34	LCD panel Backlight I/F PCB Menu keys Escutcheon Base metal plate Cable Screw cap set	Personal computer unit is prepared at the same time. Built-in disk of the display unit is prepared at the same time. Front side memory I/F is normally equipped with the display unit. (Windows-based display)
19-type color LCD touchscreen (SXGA:1024 x 1280)	FCU8-DU193-75	LCD panel Backlight I/F PCB Escutcheon Base metal plate Cable	Personal computer unit is prepared at the same time. Built-in disk of the display unit is prepared at the same time. Side memory I/F unit is separately prepared. (Windows-based display)
19-type color LCD touchscreen (SXGA:1280 x 1024)	FCU8-DU194-75	LCD panel Backlight I/F PCB Escutcheon Base metal plate Cable	Personal computer unit is prepared at the same time. Built-in disk of the display unit is prepared at the same time. Side memory I/F unit is separately prepared. (Windows-based display)

3.4 Display Unit [M80VW]

Classification	Type	Components	Remark
15-type color LCD touchscreen (XGA:1024 x 768)	FCU8-DU182-36	LCD panel Backlight I/F PCB Menu keys Escutcheon Base metal plate Cable Screw cap set	Personal computer unit is prepared at the same time. Built-in disk of the display unit is prepared at the same time. Front side memory I/F is normally equipped with the display unit. (Windows-based display)
19-type color LCD touchscreen (SXGA:1024 x 1280)	FCU8-DU193-77	LCD panel Backlight I/F PCB Escutcheon Base metal plate Cable	Personal computer unit is prepared at the same time. Built-in disk of the display unit is prepared at the same time. Side memory I/F unit is separately prepared. (Windows-based display)
19-type color LCD touchscreen (SXGA:1280 x 1024)	FCU8-DU194-77	LCD panel Backlight I/F PCB Escutcheon Base metal plate Cable	Personal computer unit is prepared at the same time. Built-in disk of the display unit is prepared at the same time. Side memory I/F unit is separately prepared. (Windows-based display)

3.5 Personal Computer Unit

Classification	Type	Components	Remark
Personal computer unit	FCU8-PC232	PC board PC cooling FAN Unit lid (Resin molded article) etc.	
Built-in disk of the display unit	FCU8-CF060G-1	Windows OS/data storage	Windows10

3.6 Keyboard Unit

Classification	Type	Components	Remark
Keyboard for 15-type display unit Clear key	FCU8-KB083	Escutcheon, key switch G402 cable Screw cap set	Full keyboard (for M system/L system) (in tandem)

3.7 Operation Panel I/O Unit

Classification	Type	Components	Remark
DI 24 V/0 V common input [64 points] DO Source output [64 points]	FCU8-DX830	Base card Add-on card RIO 2.0 terminator connector (R2-TM)	DI: 64-point 24 V/0 V common type DO: 64-point source type (200 mA/point) Manual pulse generator input: 3ch Display unit I/F Keyboard unit I/F Emergency stop input Remote I/O 2.0 I/F RIO occupied stations (fixed): 1 to 4, 7 to 14, 20 to 22 RIO extensible stations: 5, 6, 15 to 19, 23 to 64 (*1)
DI 24 V/0 V common input [64 points] DO Source output [64 points] Scan input [64 points] Scan output [64 points]	FCU8-DX834	Base card Add-on card RIO 2.0 terminator connector (R2-TM)	DI: 64-point 24 V/0 V common type DO: 64-point source type (200 mA/point) Scan input: 64 points Scan output: 64 points Manual pulse generator input: 3ch Display unit I/F Keyboard unit I/F Emergency stop input Remote I/O 2.0 I/F RIO occupied stations (fixed): 1 to 4, 7 to 14, 20 to 22 RIO extensible stations: 5, 6, 15 to 19, 23 to 64 (*1)
DI 24 V/0 V common input [64 points] DO Source output [64 points] Safety DI 24 V/0 V common input [8 points]	FCU8-DX837	Base card Add-on card RIO 2.0 terminator connector (R2-TM)	DI: 64-point 24 V/0 V common type DO: 64-point source type (200 mA/point) Safety DI: 8-point 0 V common type Manual pulse generator input: 3ch Display unit I/F Keyboard unit I/F Emergency stop input Remote I/O 2.0 I/F RIO occupied stations (fixed): 1 to 4, 7 to 14, 20 to 22 RIO extensible stations: 5, 6, 15 to 19, 23 to 64 (*1)

(*1) J291 cable is required for connection with the personal computer unit. (for windows-based display)

♦ DI: Digital input signals, DO: Digital output signals

3 List of Configuration (M800VW/M80VW Series)

3.8 Remote I/O Unit

3.8 Remote I/O Unit

Classification	Type	Components	Remark
DI 24 V/0 V common input [32 points] DO Source output [32 points]	FCU8-DX220	Base card RIO 2.0 connector set	DI: 32-point 24 V/0 V common type DO: 32-point source type (200 mA/point) Number of occupied stations: 1
DI 24 V/0 V common input [64 points] DO Source output [48 points]	FCU8-DX230	Base card RIO 2.0 connector set	DI: 64-point 24 V/0 V common type DO: 48-point source type (200 mA/point) Number of occupied stations: 2
DI 24 V/0 V common input [64 points] DO Source output [48 points] AO analog output [1 point]	FCU8-DX231	Base card RIO 2.0 connector set	DI: 64-point 24 V/0 V common type DO: 48-point source type (200 mA/point) AO: 1 point Number of occupied stations: 2
AI analog input [4 points] AO analog output [1 point]	FCU8-DX202	Base card RIO 2.0 connector set	AI: 4 points AO: 1 point Number of occupied stations: 1
DI 0 V common input [16 points] DO Source output (large capacity) [8 points]	FCU8-DX213	Base card RIO 2.0 connector set	DI: 16-point 0 V common type (3 mA/point) DO: 8-point source type (2 A/point) Number of occupied stations: 1
DI 0 V common input [16 points] DO Source output (large capacity) [8 points]	FCU8-DX213-1	Base card RIO 2.0 connector set	DI: 16-point 0 V common type (9 mA/point) DO: 8-point source type (2 A/point) Number of occupied stations: 1
Safety DI 0 V common input [8 points] Safety DO Source output (large capacity) [4 points]	FCU8-DX654	Base card RIO 2.0 connector set	Safety DI: 8-point 0 V common type (3 mA/point) Safety DO: 4-point source type (2A/point) Number of occupied stations: 2
Safety DI 0 V common input [8 points] Safety DO Source output (large capacity) [4 points]	FCU8-DX654-1	Base card RIO 2.0 connector set	Safety DI: 8-point 0 V common type (9 mA/point) Safety DO: 4-point source type (2 A/point) Number of occupied stations: 2
DI 24 V/0 V common input [32 points] DO Source output [32 points] Safety DI 0 V common input [8 points] (*1) Safety relay output [4 points] (*2)	FCU8-DX651	Base card Add-on card RIO 2.0 connector set	DI: 32-point 24 V/0 V common type DO: 32-point source type (200 mA/point) Safety DI: 8-point 0 V common type Safety relay: 4 points (non-voltage contact) Relay contact welding detection Number of occupied stations: 3
Thermistor input [12 points]	FCU8-DX408	Base card RIO 2.0 connector set	Thermistor input: 12 points Number of occupied stations: 3
Multi-analog input [4 points] (*3)	FCU8-DX409	Base card RIO 2.0 connector set	Multi-analog input: 4 points Number of occupied stations: 4

(*1) Safety DI uses 16 points of terminal because of the duplication wiring.

(*2) Safety relay output uses 8 points of terminal because of the duplication wiring.

(*3) Voltage input, current input, thermocouple input and resistance temperature detector input are selected for each channel.

♦ DI: Digital input signals, DO: Digital output signals, AI: Analog input signals, AO: Analog output signals

3.9 Laser I/F Unit

Classification	Type	Components	Remark
Laser I/F unit	FCU8-DX522-001	Base card Connector set	DI: 26-point 0 V common type DO: 22-point source type (200 mA/point) PWM output: 1 point Relay: 3 points (non-voltage contact) AI: 1 point AO: 1 point Remote I/O occupies 1 ch.

3.10 Function Expansion Unit

[Connector: EXT1/EXT2 on the control unit]

Classification	Type	Components	Remark
Encoder (manual pulse generator) I/F expansion unit	FCU8-EX544	Encoder I/F PCB	Encoder input 1ch 5 V manual pulse generator input 2ch

[Connector: EXT3/EXT4 on the control unit]

Classification	Type	Components	Remark
CC-Link expansion unit	FCU8-EX561	CC-Link I/F PCB	CC-Link 1 ch
PROFIBUS-DP master unit	FCU8-EX563	PROFIBUS-DP I/F PCB	PROFIBUS-DP 1 ch
CC-Link IE Field Master/local unit	FCU8-EX564	Base card Add-on card	CC-Link IE Field 2 ch
EtherNet/IP scanner/adaptor unit	FCU8-EX565	Base card Add-on card	EtherNet/IP 1 ch (LAN1 only; LAN2 unavailable)
FL-net expansion unit	FCU8-EX568	Base card Add-on card	FL-net 1 ch (LAN1 only; LAN2 unavailable)
Vibration cutting expansion unit	FCU8-EX744	Base card	Vibration cutting function

3.11 Side Memory I/F Unit

Classification	Type	Components	Remark
Side memory I/F unit	FCU8-EP201-2	Side memory I/F PCB J292 cable Structural member	SDHC: 1 ch USB2.0 1 ch USB communication (between side memory I/F PCB and personal computer) Unit lid (resin molded article), metal plate, etc. Exclusive for 19-type display unit

3.12 Manual Pulse Generator

Classification	Type	Components	Remark
5 V manual pulse generator	UFO-01-2Z9	UFO-01-2Z9 (Produced by NIDEC NEMICON)	Input: DC5 V 100 pulse/rev
12V manual pulse generator	HD60C	HD60C	Input: DC12 V 25 pulse/rev

3.13 Synchronous Feed Encoder

Classification	Type name	Components	Remark
Synchronous feed encoder	OSE1024-3-15-68	OSE1024-3-15-68	Input: DC5 V 1024 pulse/rev 6000 rpm, 68-square flange
Synchronous feed encoder	OSE1024-3-15-68-8	OSE1024-3-15-68-8	Input: DC5 V 1024 pulse/rev 8000 rpm, 68-square flange
Synchronous feed encoder	OSE1024-3-15-160	OSE1024-3-15-160	Input: DC5 V 1024 pulse/rev 6000 rpm, 160-square flange

3 List of Configuration (M800VW/M80VW Series)

3.14 Machine Operation Panel

3.14 Machine Operation Panel

Classification	Type name	Components	Remark
Main panel A (For 8.4-type/15-type display unit)	FCU8-KB921	Escutcheon, key switch Control card G054 cable, screw cap set	Mitsubishi Electric standard key layout (55 keys) (Standard specification A)
Main panel A (For 8.4-type/15-type display unit)	FCU8-KB922	Escutcheon, key switch Control card G054 cable, screw cap set	Custom specification, 55-key layout (Clear key top cover sold separately)
Main panel B (For 10.4-type display unit)	FCU8-KB923	Escutcheon, key switch Control card G054 cable, screw cap set	Mitsubishi Electric standard key layout (55 keys) (Standard specification A)
Main panel B (For 10.4-type display unit)	FCU8-KB924	Escutcheon, key switch Control card G054 cable, screw cap set	Custom specification, 55-key layout (Clear key top cover sold separately)
Main panel A (For 8.4-type/15-type display unit)	FCU8-KB925	Escutcheon, key switch Control card G054 cable, screw cap set	Mitsubishi Electric standard key layout (55 keys) (Standard specification B)
Main panel B (For 10.4-type display unit)	FCU8-KB926	Escutcheon, key switch Control card G054 cable, screw cap set	Mitsubishi Electric standard key layout (55 keys) (Standard specification B)
Sub panel A (Common for all display units)	FCU8-KB931	Escutcheon Emergency stop switch, override switch ON/OFF switch, screw cap set	Mitsubishi Electric standard switch spec- ification (Standard specification A)
Sub panel A (Common for all display units)	FCU8-KB941	Escutcheon Emergency stop switch, override switch ON/OFF switch, screw cap set	Mitsubishi Electric standard switch spec- ification (Standard specification B)
Clear key top set	N030C975G51/ N030C975G55	Clear key top cover (20 pieces/60 pic- es)	
Set of labels for M7 standard key layout	N939A169G51	Labels for M7 standard key layout (1 sheet)	

3.15 Handy Terminal

Classification	Type name	Components	Remark
Handy terminal	HG1T-SB12UH- MK1346-L5		

3.16 Cable Connector Sets

Classification	Type name	Components	Remark
General I/O (For SKIP, SIO, MPG, AIO)	FCUA-CS000	Connector (10120-3000PE, 2 pcs.) Shell kit (10320-52F0-008, 2 pcs.)	
Emergency stop connector (For EMG)	005057-9403 0016020103 x 3 pcs.	Connector (50-57-9403), Contact (0016020103, 3 pcs.)	
Connector kit for RIO 2.0 unit	RIO2 CON	Connector (1-1318119-3, 2 pcs.), Contact (1318107-1, 8 pcs.), Connector (2-178288-3), Contact (1-175218-5, 3 pcs.)	
Connector kit for laser I/F	RIOL-CON	Connector (1-1318119-3, 2 pcs.), Contact (1318107-1, 8 pcs.), Connector (2-178288-3, 2 pcs.), Contact (1-175218-5, 6 pcs.)	
24 VDC power supply connector (For DCIN)	FCUA-CN220	Connector (2-178288-3), Contact (1-175218-5, 3 pcs.)	
DI/DO Connector (for operation panel I/O unit) (for remote I/O unit)	7940-6500SC x 4 pieces 3448-7940 x 4 pcs.	Connector (7940-6500SC, 4 pcs.), Strain relief (3448-7940, 4 pcs.)	
ON/OFF switch connector	005057-9404 0016020103 x 4 pcs.	Connector (50-57-9404), Contact (0016020103, 4 pcs.)	
THERMISTOR connector	37104-2165-000FL 10P	Connector (37104-2165-000FL, 10 pieces)	

3.17 Thermistor Set

Classification	Type name	Components	Remark
Thermistor	PT3C-51F-M2 10P	Thermistor (PT3C-51F-M2, 10 pieces)	

3.18 Genuine Memory Card

Classification	Type name	Components	Remark
Exclusive SD cards for 1 GB	FCU8-SD001G	FCU8-SD001G	1 GB capacity
Exclusive SD cards for 4 GB	FCU8-SD004G	FCU8-SD004G	4 GB capacity

3.19 Durable Parts

Durable parts	Part type
Battery for control unit	Q6BAT
Battery for personal computer unit	Q6BAT
Cooling fan for personal computer unit	109P0424H3103

- ♦ Contact the Service Center, Sales Office or dealer for repairs or part replacement.

3.20 Replacements

Replacements	Part type	Manufacturer
Protection fuse for operation panel I/O unit	LM50	Daito Communication Apparatus Co., Ltd.
Protection fuse for FCU8-DX220/230/231	LM50	Daito Communication Apparatus Co., Ltd.
Protection fuse for FCU8-DX213/654/213-1/654-1	MP63	Daito Communication Apparatus Co., Ltd.
Protection fuse for FCU8-DX522-001	LM50	Daito Communication Apparatus Co., Ltd.
Pair of SD/USB covers for display unit	N031C089G51	-

3 List of Configuration (M800VW/M80VW Series)

3.21 List of Cables

3.21 List of Cables

[Cable relating to NC]

Type name	Application	Available cable length (m)	Max. cable length
FCUA-R050-xM	Wiring between synchronous encoder and control unit (straight, with connector) (for FCU8-EX544)	5	30 m
FCUA-R054-xM	Wiring between synchronous encoder and control unit (right angle, with connector) (for FCU8-EX544)	3, 5, 10, 15, 20	30 m
G071 LxM	24 VDC relay cable for machine operation panel	0.12, 0.5, 1	1 m
G123	Cable for emergency stop release	-	-
G170 LxM	ON/OFF switch cable (for wiring between ON/OFF switch and personal computer unit) (for windows-based display)	1 to 2, 3 to 5, 10 to 15	15 m
G430 LxM	Cable for connection to handy terminal	3, 5, 10	10 m
G460 LxM	Cable for machine operation panel (for wiring between main panel and sub panel)	0.5	0.5 m
J020 LxM	Manual pulse generator cable (12 V): 1 ch	1, 2, 3, 5, 7, 10, 15, 20, 30	50 m
J021 LxM	Manual pulse generator cable (12 V): 2 ch	1, 2, 3, 5, 7, 10, 15, 20, 30	50 m
J022 LxM	Manual pulse generator cable (12 V): 3 ch	1, 2, 3, 5, 7, 10, 15, 20, 30	50 m
J023 LxM	Manual pulse generator cable (5 V): 1 ch	1, 2, 3, 5, 7, 10, 15, 20	20 m
J024 LxM	Manual pulse generator cable (5 V): 2 ch	1, 2, 3, 5, 7, 10, 15, 20	20 m
J025 LxM	Manual pulse generator cable (5 V): 3 ch	1, 2, 3, 5, 7, 10, 15, 20	20 m
J026 LxM	Manual pulse generator cable (5 V): 1 ch (For connection to control unit)	1, 2, 3, 5, 7, 10, 15, 20	20 m (*)
J027 LxM	Manual pulse generator cable (5 V): 2 ch (For connection to control unit)	1, 2, 3, 5, 7, 10, 15, 20	20 m (*)
J030 LxM	RS-232C I/F cable: 1 ch	1, 2, 3, 5, 7, 10	15 m (*)
J031 LxM	RS-232C I/F cable: 2 ch	1, 2, 3, 5, 7, 10	15 m (*)
J070 LxM	24 VDC power cable	1, 2, 3, 5, 7, 10, 15	15 m
J071 LxM	24 VDC power cable (for long distance)	20	20 m
J100 LxM	SKIP input cable	1, 2, 3, 5, 7, 10, 15, 20	20 m
J120 LxM	Emergency stop cable	1, 2, 3, 5, 7, 10, 15, 20, 30	30 m
J121 LxM	Emergency stop cable for machine operation panel	1, 2, 3, 5, 7, 10, 15, 20, 30	30 m
J210 LxM	Remote I/O 2.0 communication cable	0.3, 1, 2, 3, 5, 7, 10, 15, 20, 30	50 m
J220 LxM	Analog output cable (for M800VW)	2, 3, 7	30 m
J221 LxM	Analog input/output cable (for remote I/O unit)	2, 3, 7	30 m
J291 LxM	Connection cable between personal computer unit and operation panel I/O unit	0.15, 0.5, 1	1 m
J303 LxM	LAN straight cable	1, 2, 3, 5, 7, 10, 15, 20, 30	50 m
J350 LxM	DI/DO cable (connectors at both ends)	1, 2, 3, 5	50m
J351 LxM	DI/DO cable (connector at one end)	3	50 m
J460 LxM	DI/DO cable (connectors at both ends)	1, 2, 3, 5	50 m
J461 LxM	DI/DO cable (connector at one end)	3	50 m
R2-TM	Terminator for remote I/O interface	-	-

Note

- (1) "x" in type columns indicate cable length (unit: m).
- (2) Lengths indicated with an asterisk (*) in the max. cable length column indicate the maximum cable length when connecting via other unit.

[Cable Relating to Drive Unit]

Type name	Application	Available cable length (m)	Max. cable length
CNP2E-1-xM	Motor side PLG cable Spindle side accuracy encoder TS5690 cable	2, 3, 4, 5, 7, 10, 15, 20, 25, 30	30 m
CNP3EZ-2P-xM	Spindle side detector cable OSE-1024 cable	2, 3, 4, 5, 7, 10, 15, 20, 25, 30	30 m
CNP3EZ-3P-xM	Spindle side detector cable OSE-1024 cable	2, 3, 4, 5, 7, 10, 15, 20, 25, 30	30 m
CNV2E-8P-xM	For HG/HG-H, HQ-H, HK/HK-H, HG-JR Motor side encoder cable (for D47/D48/D51/D74/G48) Ball screw side encoder cable (OSA405ET2AS, OSA676ET2AS)	2, 3, 4, 5, 7, 10, 15, 20, 25, 30	30 m
CNV2E-9P-xM	For HG/HG-H, HQ-H, HK/HK-H, HG-JR Motor side encoder cable (for D47/D48/D51/D74/G48) Ball screw side encoder cable (OSA405ET2AS, OSA676ET2AS)	2, 3, 4, 5, 7, 10, 15, 20, 25, 30	30 m
MR-ENE4CBLxM-HMTH	For HG-H1502 Motor side encoder cable (for D48/D51/D74)	5, 10, 20, 30	30 m
CNV2E-D-xM	MDS-B-SD unit cable	2, 3, 4, 5, 7, 10, 15, 20, 25, 30	30 m
CNV2E-HP-xM	MDS-EX-HR unit cable	2, 3, 4, 5, 7, 10, 15, 20, 25, 30	30 m
DG30-xM	Battery cable (for wiring between drive unit and battery box, between drive units)	0.3, 0.5, 1, 2, 3, 5, 7, 10	10 m
G380 LxM	Optical communication cable Wiring between drive units (outside panel)	5, 10, 12, 15, 20, 25, 30	30 m
J395 LxM	Optical communication cable Wiring between drive units (outside panel) Wiring between NC and-drive unit	3, 5, 7, 10	10 m
J396 LxM	Optical communication cable Wiring between drive units (inside panel)	0.2, 0.3, 0.5, 1, 2, 3, 5	10 m
MR-BKS1CBLxMA1-H	<200V Series> Brake cable for HG96 load side angle	2, 3, 5, 7, 10	10 m
MR-BKS1CBLxMA2-H	<200V Series> Brake cable for HG96 reverse load side angle	2, 3, 5, 7, 10	10 m
MR-BT6V2CBL LxM	Battery cable (MDS-EJ/EJH) (for wiring between drive units)	0.3, 1	1 m
MR-D05UDL3M-B	STO cable	3	3 m
MR-PWS1CBLxMA1-H	<200V Series> Power cable for HG96 load side angle	2, 3, 5, 7, 10	10 m
MR-PWS1CBLxMA2-H	<200V Series> Power cable for HG96 reverse load side angle	2, 3, 5, 7, 10	10 m
SH21 LxM	Power supply communication cable Backup unit communication cable	0.35, 0.5, 1, 2, 3	30 m

Note

- "x" in type columns indicate cable length (unit: m).
- Lengths indicated with an asterisk (*) in the max. cable length column indicate the maximum cable length when connecting via other unit.

3.22 System Type

Series	Model name	System type	Control unit
M800VW Series	M850VW	FCA850U-V	FCU8-MA051-001
	M830VW	FCA830U-V	FCU8-MU052-001
M80VW Series	M80VW	FCA80U-V	FCU8-MU054-001

General Specifications (M800VW/M80VW Series)

4.1 Environment Conditions [M800VW]

4.1.1 Environment Conditions Inside the Operation Panel

Item	Unit name		Display unit	Personal computer unit
	Type		FCU8-DU182-34: (15-type) FCU8-DU193-75: (19-type) FCU8-DU194-75: (19-type)	FCU8-PC232
General specifications	Ambient temperature	During operation	0 °C to 58 °C	
		During storage	-20 °C to 60 °C	
	Ambient humidity	Long term	10% to 75% RH (with no dew condensation)	
		Short term	10% to 95% RH (with no dew condensation) (*1)	
	Vibration resistance		4.9 m/s ² [0.5 G] or less	
	Shock resistance		29.4 m/s ² [3 G] or less	
	Working atmosphere		No corrosive gases, dust or oil mist	
	Altitude		Operation/Storage: 1000 meters or less above sea level, Transportation: 13000 meters or less above sea level	
	Power supply voltage		FCU8-DU182-34: 12 VDC/5 VDC/3.3 VDC FCU8-DU193-75: 12 VDC/5 VDC FCU8-DU194-75: 12 VDC/5 VDC (Supplied from personal computer unit)	24 VDC
	Current consumption		- (*2)	2.2 A
	Maximum heating value	(W)	FCU8-DU182-34: 20.5 FCU8-DU193-75: 33 FCU8-DU194-75: 33	19
	Mass	(kg)	FCU8-DU182-34: 3.9 FCU8-DU193-75: 5.2 FCU8-DU194-75: 5.2	1.2
	Outline dimensions W × H or W × H × D	(mm)	FCU8-DU182-34: 400 × 320 FCU8-DU193-75: 365 × 440 FCU8-DU194-75: 440 × 365	237 × 182 × 53.5

(*1) "Short term" means within one month.

(*2) The current consumption of the display unit is included in that of the personal computer unit.

Note

(1) For the whole NC system, consider the characteristics of the drive units when the altitude is more than 1000 meters above sea level.

Refer to the manual of drive unit for details.

(2) When the display unit is mounted on an incline, the inclination angle to place the unit should follow below.

15-type display unit: The inclination should be 30 degrees or less from the vertical direction.

19-type display unit: The inclination should be 60 degrees or less from the vertical direction.

4 General Specifications (M800VW/M80VW Series)

4.1 Environment Conditions [M800VW]

Item	Unit name		Keyboard unit	Operation panel I/O unit	Machine operation panel
	Type		FCU8-KB083: (15-type/vertical arrangement)	FCU8-DX830/DX834/DX837	FCU8-KB921/KB922/KB925 FCU8-KB923/KB924/KB926 FCU8-KB931/KB941
General specifications	Ambient temperature	During operation	0 °C to 58 °C		
		During storage	-20 °C to 60 °C		
	Ambient humidity	Long term	10% to 75% RH (with no dew condensation)		
		Short term	10% to 95% RH (with no dew condensation) (*1)		
	Vibration resistance		4.9 m/s ² [0.5 G] or less		
	Shock resistance		29.4 m/s ² [3 G] or less		
	Working atmosphere		No corrosive gases, dust or oil mist		
	Altitude		Operation/Storage: 1000 meters or less above sea level, Transportation: 13000 meters or less above sea level		
	Power supply voltage		5 VDC (Supply from operation panel I/O unit)	24 VDC	24 VDC (*5)
	Current consumption		- (*2)	0.3 A (*3)	0.3 A (*5)
	Maximum heating value	(W)	1	8 (*4)	7.2
	Mass	(kg)	1.5	0.4	FCU8-KB921/KB922/KB925: 1.1 FCU8-KB923/KB924/KB926: 1.2 FCU8-KB931/KB941: 0.5
	Outline dimensions W × H	(mm)	400 × 140	116 × 179	FCU8-KB921/KB922/KB925: 260 × 140 FCU8-KB923/KB924/KB926: 290 × 140 FCU8-KB931/KB941: 140 × 140

(*1) "Short term" means within one month.

(*2) The current consumption of the keyboard unit is included in that of the operation panel I/O unit.

(*3) Current consumption for the I/O circuit needs to be separately calculated based on the number of points used and its load.

(*4) For the heating value of the I/O circuit, calculate with the number of points used.

(*5) 24 V power input is not required for FCU8-KB931/KB941.

Note

(1) For the whole NC system, consider the characteristics of the drive units when the altitude is more than 1000 meters above sea level.

Refer to the manual of drive unit for details.

4.1.2 Environment Conditions Inside the Control Panel

Item	Unit name		Control unit
	Type		FCU8-MU052/MA051
General specifications	Ambient temperature	During operation	0 °C to 55 °C
		During storage	-20 °C to 60 °C
	Ambient humidity	Long term	10% to 75% RH (with no dew condensation)
		Short term	10% to 95% RH (with no dew condensation) (*1)
	Vibration resistance		4.9 m/s ² [0.5 G] or less
	Shock resistance		29.4 m/s ² [3 G] or less
	Working atmosphere		No corrosive gases, dust or oil mist
	Altitude		Operation/Storage: 1000 meters or less above sea level, Transportation: 13000 meters or less above sea level
	Power supply voltage		24 VDC
	Current consumption		1.5 A
	Maximum heating value	(W)	16
	Mass	(kg)	1.9
Outline dimensions W × H × D	(mm)	90 × 380 × 180	

(*1) "Short term" means within one month.

Note

(1) For the whole NC system, consider the characteristics of the drive units when the altitude is more than 1000 meters above sea level.

Refer to the manual of drive unit for details.

4 General Specifications (M800VW/M80VW Series)

4.1 Environment Conditions [M800VW]

Item	Unit name		Remote I/O unit					
	Type		FCU8-DX220/ DX230/DX231	FCU8-DX202	FCU8-DX213/ DX213-1/ DX654/ DX654-1	FCU8-DX408	FCU8-DX409	FCU8-DX651
General specifications	Ambient temperature	During operation	0 °C to 58 °C					
		During storage	-20 °C to 60 °C					
	Ambient humidity	Long term	10% to 75% RH (with no dew condensation)					
		Short term	10% to 95% RH (with no dew condensation) (*1)				10% to 85% RH (with no dew condensation) (*1)	
	Vibration resistance		4.9 m/s ² or less					
	Shock resistance		29.4 m/s ² or less					
	Working atmosphere		No corrosive gases, dust or oil mist					
	Altitude		Operation/Storage: 1000 meters or less above sea level, Transportation: 13000 meters or less above sea level					
	Power supply voltage		24 VDC					
	Current consumption		3.5 A (*2)	0.3 A	0.3 A (*3)	0.1 A	0.2 A	3.7 A (*2)
	Maximum heating value	(W)	8 (*4)			3	6 (*5)	8 (*4)
	Mass	(kg)	0.4			0.2	0.3	0.8
	Outline dimensions W × H × D	(mm)	40 × 175 × 133	40 × 175 × 119	40 × 175 × 130	40 × 175 × 109	40 × 175 × 130	104 × 175 × 115

(*1) "Short term" means roughly within one month.

(*2) This value includes the maximum value of DO external load current (3.2 A).

(*3) This value does not include DO external load current.

(*4) For the heating value of the I/O circuit, calculate with the number of points used.

(*5) The maximum value including the heating value of analog input circuit.

Note

(1) For the whole NC system, consider the characteristics of the drive units when the altitude is more than 1000 meters above sea level.

Refer to the manual of drive unit for details.

4 General Specifications (M800VW/M80VW Series)

4.1 Environment Conditions [M800VW]

Item	Unit name		Laser I/F unit
	Type		FCU8-DX522-001
General specifications	Ambient temperature	During operation	0 °C to 58 °C
		During storage	-20 °C to 60 °C
	Ambient humidity	Long term	10% to 75% RH (with no dew condensation)
		Short term	10% to 95% RH (with no dew condensation) (*1)
	Vibration resistance		4.9 m/s ² or less
	Shock resistance		29.4 m/s ² or less
	Working atmosphere		No corrosive gases, dust or oil mist
	Altitude		Operation/Storage: 1000 meters or less above sea level, Transportation: 13000 meters or less above sea level
	Power supply voltage		24 VDC
	Current consumption		0.3 A (*2)
	Maximum heating value	(W)	8 (*3)(*4)
	Mass	(kg)	0.4
Outline dimensions W × H × D	(mm)	40 × 175 × 133	

(*1) "Short term" means roughly within one month.

(*2) This value does not include DO external load current.

(*3) For the heating value of the I/O circuit, calculate with the number of points used.

(*4) The maximum value including the heating value of analog input circuit.

Note

(1) For the whole NC system, consider the characteristics of the drive units when the altitude is more than 1000 meters above sea level.

Refer to the manual of drive unit for details.

4.1.3 24 VDC Stabilized Power Supply Selecting Conditions

Consider the following characteristics for the stabilized power supply, and select the power supply that complies with laws, regulations, or safety standards of the country where the machine will be installed.

	Item	Specifications	Remarks
Output	Voltage	24 VDC	When the stabilized power supply and 24 VDC input unit are distant, select the stabilized power supply which is possible to set output voltage 24 VDC or more allowing for the influence of voltage down by the cable.
	Voltage fluctuation	±5%	
	Current	-	Calculate the current value as a reference of maximum current consumption for the unit which uses the power supply.
	Ripple noise	0.2 V (P-P)	
	Output holding time	min 20ms	Output holding time is decided by loading ratio; however, the stabilized power supply which complies with the specification on the left must be selected during maximum loading.
	Overcurrent output shutoff function	-	Use a power supply having the overcurrent output shutoff function.

CAUTION

Using a stabilized power supply without overcurrent protection may cause the unit's failure due to miswiring of 24 V.

4.2 Environment Conditions [M80VW]

4.2.1 Environment Conditions Inside the Operation Panel

Item	Unit name		Display unit	Personal computer unit
	Type		FCU8-DU182-36: (15-type) FCU8-DU193-77: (19-type) FCU8-DU194-77: (19-type)	FCU8-PC232
General specifications	Ambient temperature	During operation	0 °C to 58 °C	
		During storage	-20 °C to 60 °C	
	Ambient humidity	Long term	10% to 75% RH (with no dew condensation)	
		Short term	10% to 95% RH (with no dew condensation) (*1)	
	Vibration resistance		4.9 m/s ² [0.5 G] or less	
	Shock resistance		29.4 m/s ² [3 G] or less	
	Working atmosphere		No corrosive gases, dust or oil mist	
	Altitude		Operation/Storage: 1000 meters or less above sea level, Transportation: 13000 meters or less above sea level	
	Power supply voltage		FCU8-DU182-36: 12 VDC/5 VDC/3.3 VDC FCU8-DU193-77: 12 VDC/5 VDC FCU8-DU194-77: 12 VDC/5 VDC (Supplied from personal computer unit)	24 VDC
	Current consumption		- (*2)	2.2 A
	Maximum heating value	(W)	FCU8-DU182-36: 20.5 FCU8-DU193-77: 33 FCU8-DU194-77: 33	19
	Mass	(kg)	FCU8-DU182-36: 3.9 FCU8-DU193-77: 5.2 FCU8-DU194-77: 5.2	1.2
	Outline dimensions W × H or W × H × D	(mm)	FCU8-DU182-36: 400 × 320 FCU8-DU193-77: 365 × 440 FCU8-DU194-77: 440 × 365	237 × 182 × 53.5

(*1) "Short term" means within one month.

(*2) The current consumption of the display unit is included in that of the personal computer unit.

Note

(1) For the whole NC system, consider the characteristics of the drive units when the altitude is more than 1000 meters above sea level.

Refer to the manual of drive unit for details.

(2) When the display unit is mounted on an incline, the inclination angle to place the unit should follow below.

15-type display unit: The inclination should be 30 degrees or less from the vertical direction.

19-type display unit: The inclination should be 60 degrees or less from the vertical direction.

4 General Specifications (M800VW/M80VW Series)

4.2 Environment Conditions [M80VW]

Item	Unit name		Keyboard unit	Operation panel I/O unit	Machine operation panel
	Type		FCU8-KB083: (15-type/vertical arrangement)	FCU8-DX830/DX834/DX837	FCU8-KB921/KB922/KB925 FCU8-KB923/KB924/KB926 FCU8-KB931/KB941
General specifications	Ambient temperature	During operation	0 °C to 58 °C		
		During storage	-20 °C to 60 °C		
	Ambient humidity	Long term	10% to 75% RH (with no dew condensation)		
		Short term	10% to 95% RH (with no dew condensation) (*1)		
	Vibration resistance		4.9 m/s ² [0.5 G] or less		
	Shock resistance		29.4 m/s ² [3 G] or less		
	Working atmosphere		No corrosive gases, dust or oil mist		
	Altitude		Operation/Storage: 1000 meters or less above sea level, Transportation: 13000 meters or less above sea level		
	Power supply voltage		5 VDC (Supply from operation panel I/O unit)	24 VDC	24 VDC (*5)
	Current consumption		- (*2)	0.3 A (*3)	0.3 A (*5)
	Maximum heating value	(W)	1	8 (*4)	7.2
	Mass	(kg)	1.5	0.4	FCU8-KB921/KB922/KB925: 1.1 FCU8-KB923/KB924/KB926: 1.2 FCU8-KB931/KB941: 0.5
Outline dimensions W × H	(mm)	400 × 140	116 × 179	FCU8-KB921/KB922/KB925: 260 × 140 FCU8-KB923/KB924/KB926: 290 × 140 FCU8-KB931/KB941: 140 × 140	

(*1) "Short term" means within one month.

(*2) The current consumption of the keyboard unit is included in that of the operation panel I/O unit.

(*3) Current consumption for the I/O circuit needs to be separately calculated based on the number of points used and its load.

(*4) For the heating value of the I/O circuit, calculate with the number of points used.

(*5) 24 V power input is not required for FCU8-KB931/KB941.

Note

(1) For the whole NC system, consider the characteristics of the drive units when the altitude is more than 1000 meters above sea level.

Refer to the manual of drive unit for details.

4.2.2 Environment Conditions Inside the Control Panel

Item	Unit name		Control unit
	Type		FCU8-MU054
General specifications	Ambient temperature	During operation	0 °C to 55 °C
		During storage	-20 °C to 60 °C
	Ambient humidity	Long term	10% to 75% RH (with no dew condensation)
		Short term	10% to 95% RH (with no dew condensation) (*1)
	Vibration resistance		4.9 m/s ² [0.5 G] or less
	Shock resistance		29.4 m/s ² [3 G] or less
	Working atmosphere		No corrosive gases, dust or oil mist
	Altitude		Operation/Storage: 1000 meters or less above sea level, Transportation: 13000 meters or less above sea level
	Power supply voltage		24 VDC
	Current consumption		1.25 A
	Maximum heating value	(W)	16
	Mass	(kg)	2.0
	Outline dimensions W × H × D	(mm)	60 × 380 × 180

(*1) "Short term" means within one month.

Note

(1) For the whole NC system, consider the characteristics of the drive units when the altitude is more than 1000 meters above sea level.

Refer to the manual of drive unit for details.

4 General Specifications (M800VW/M80VW Series)

4.2 Environment Conditions [M80VW]

Item	Unit name		Remote I/O unit					
	Type		FCU8-DX220/ DX230/DX231	FCU8-DX202	FCU8-DX213/ DX213-1/ DX654/ DX654-1	FCU8-DX408	FCU8-DX409	FCU8-DX651
General specifications	Ambient temperature	During operation	0 °C to 58 °C					
		During storage	-20 °C to 60 °C					
	Ambient humidity	Long term	10% to 75% RH (with no dew condensation)					
		Short term	10% to 95% RH (with no dew condensation) (*1)				10% to 85% RH (with no dew condensation) (*1)	
	Vibration resistance		4.9 m/s ² or less					
	Shock resistance		29.4 m/s ² or less					
	Working atmosphere		No corrosive gases, dust or oil mist					
	Altitude		Operation/Storage: 1000 meters or less above sea level, Transportation: 13000 meters or less above sea level					
	Power supply voltage		24 VDC					
	Current consumption		3.5 A (*2)	0.3 A	0.3 A (*3)	0.1 A	0.2 A	3.7 A (*2)
	Maximum heating value	(W)	8 (*4)			3	6 (*5)	8 (*4)
	Mass	(kg)	0.4			0.2	0.3	0.8
	Outline dimensions W × H × D	(mm)	40 × 175 × 133	40 × 175 × 119	40 × 175 × 130	40 × 175 × 109	40 × 175 × 130	104 × 175 × 115

(*1) "Short term" means roughly within one month.

(*2) This value includes the maximum value of DO external load current (3.2 A).

(*3) This value does not include DO external load current.

(*4) For the heating value of the I/O circuit, calculate with the number of points used.

(*5) The maximum value including the heating value of analog input circuit.

Note

(1) For the whole NC system, consider the characteristics of the drive units when the altitude is more than 1000 meters above sea level.

Refer to the manual of drive unit for details.

4 General Specifications (M800VW/M80VW Series)

4.2 Environment Conditions [M80VW]

Item	Unit name		Laser I/F unit
	Type		FCU8-DX522-001
General specifications	Ambient temperature	During operation	0 °C to 58 °C
		During storage	-20 °C to 60 °C
	Ambient humidity	Long term	10% to 75% RH (with no dew condensation)
		Short term	10% to 95% RH (with no dew condensation) (*1)
	Vibration resistance		4.9 m/s ² or less
	Shock resistance		29.4 m/s ² or less
	Working atmosphere		No corrosive gases, dust or oil mist
	Altitude		Operation/Storage: 1000 meters or less above sea level, Transportation: 13000 meters or less above sea level
	Power supply voltage		24 VDC
	Current consumption		0.3 A (*2)
	Maximum heating value	(W)	8 (*3)(*4)
	Mass	(kg)	0.4
Outline dimensions W × H × D	(mm)	40 × 175 × 133	

(*1) "Short term" means roughly within one month.

(*2) This value does not include DO external load current.

(*3) For the heating value of the I/O circuit, calculate with the number of points used.

(*4) The maximum value including the heating value of analog input circuit.

Note

(1) For the whole NC system, consider the characteristics of the drive units when the altitude is more than 1000 meters above sea level.

Refer to the manual of drive unit for details.

4.2.3 24 VDC Stabilized Power Supply Selecting Conditions

Consider the following characteristics for the stabilized power supply, and select the power supply that complies with laws, regulations, or safety standards of the country where the machine will be installed.

	Item	Specifications	Remarks
Output	Voltage	24 VDC	When the stabilized power supply and 24 VDC input unit are distant, select the stabilized power supply which is possible to set output voltage 24 VDC or more allowing for the influence of voltage down by the cable.
	Voltage fluctuation	±5%	
	Current	-	Calculate the current value as a reference of maximum current consumption for the unit which uses the power supply.
	Ripple noise	0.2 V (P-P)	
	Output holding time	min 20ms	Output holding time is decided by loading ratio; however, the stabilized power supply which complies with the specification on the left must be selected during maximum loading.
	Overcurrent output shutoff function	-	Use a power supply having the overcurrent output shutoff function.

CAUTION

Using a stabilized power supply without overcurrent protection may cause the unit's failure due to miswiring of 24 V.

4.3 Control Unit [M800VW]

4.3.1 M830VW(FCU8-MU052)/M850VW(FCU8-MA051)

Outline dimensions

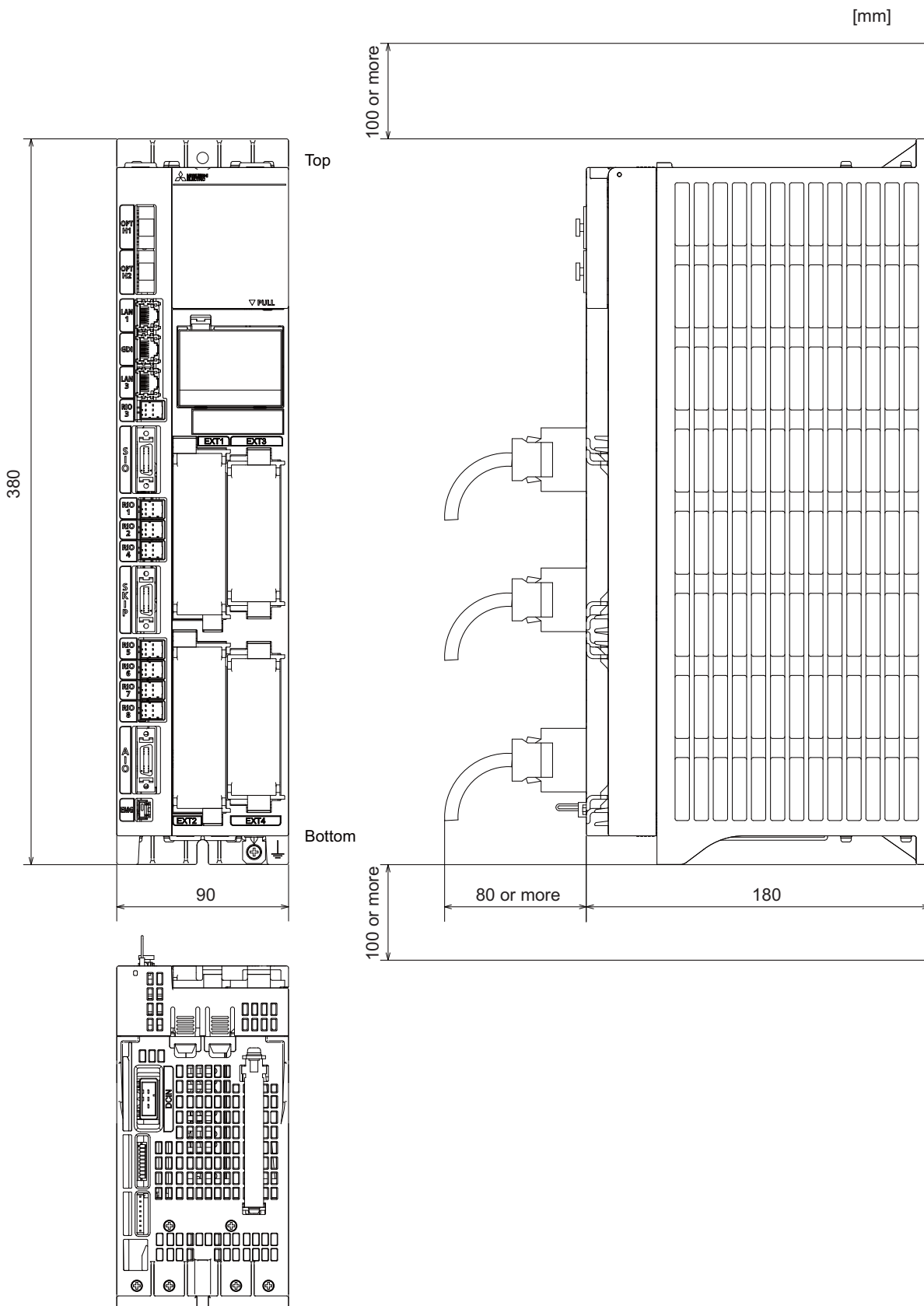

Installation dimensions

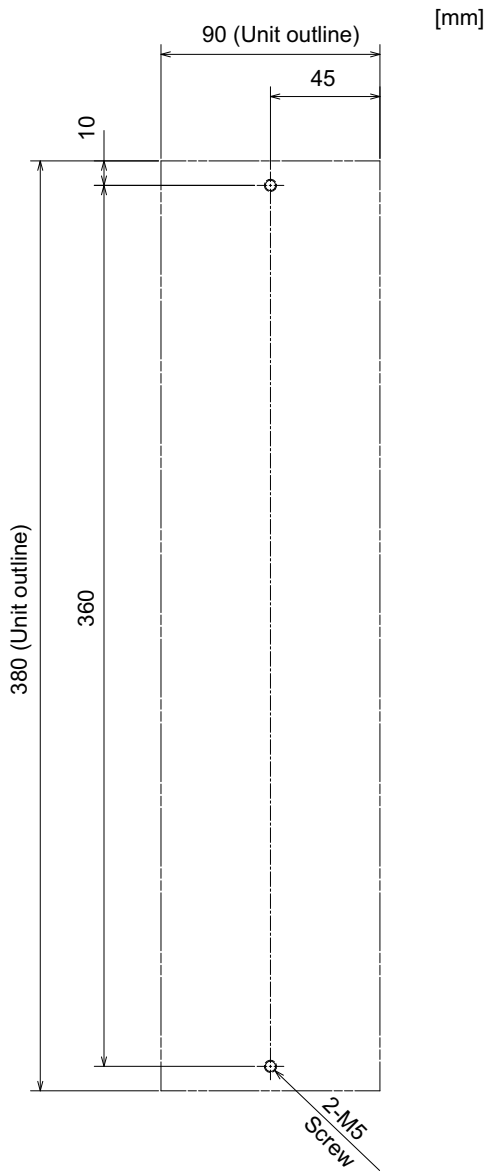

4.4 Control Unit [M80VW]

4.4.1 FCU8-MU054

Outline dimensions

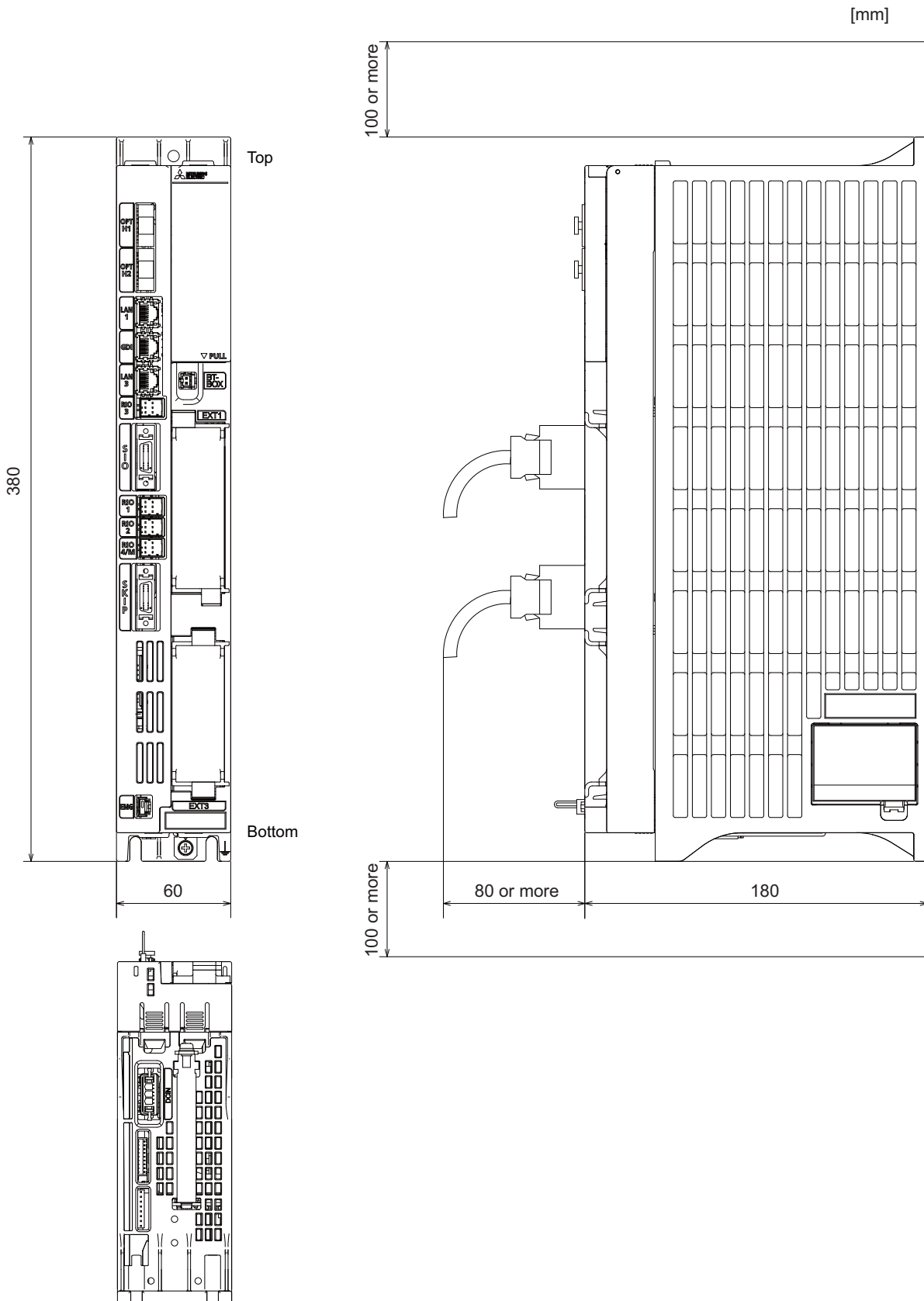

Installation dimensions

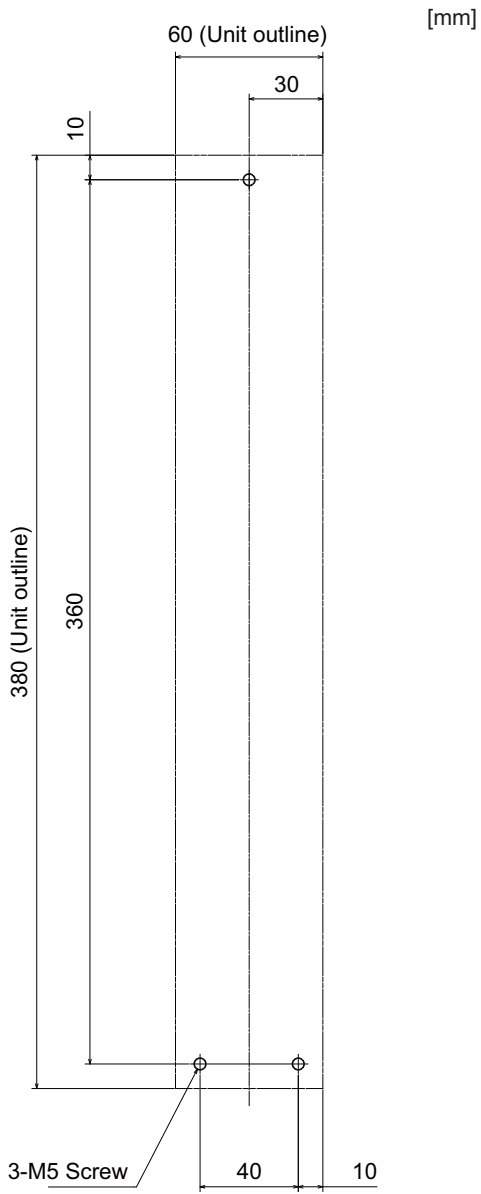

4.5 Display Unit [M800VW]

4.5.1 15-type (FCU8-DU182-34)

Outline dimensions

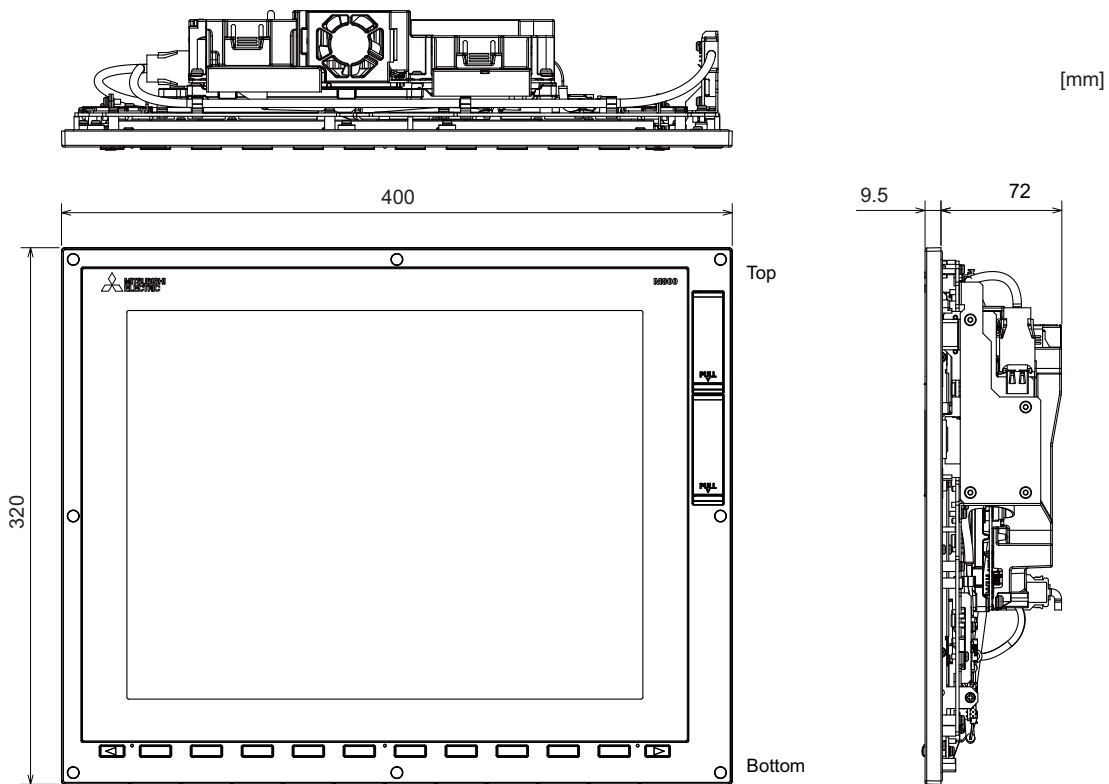

Note

(1) The figure above shows the state with the personal computer unit mounted.

Panel cut dimensions

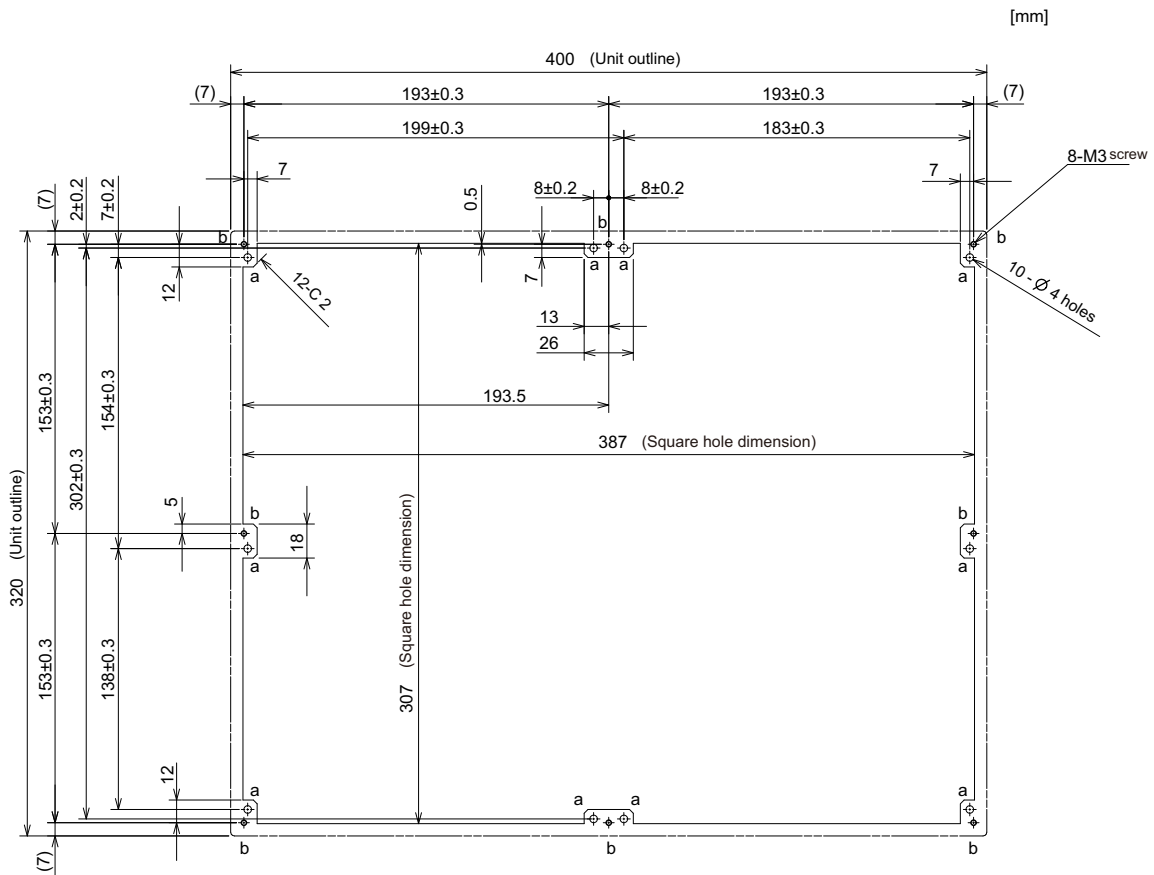

4.5.2 19-type (FCU8-DU193-75)

Outline dimensions

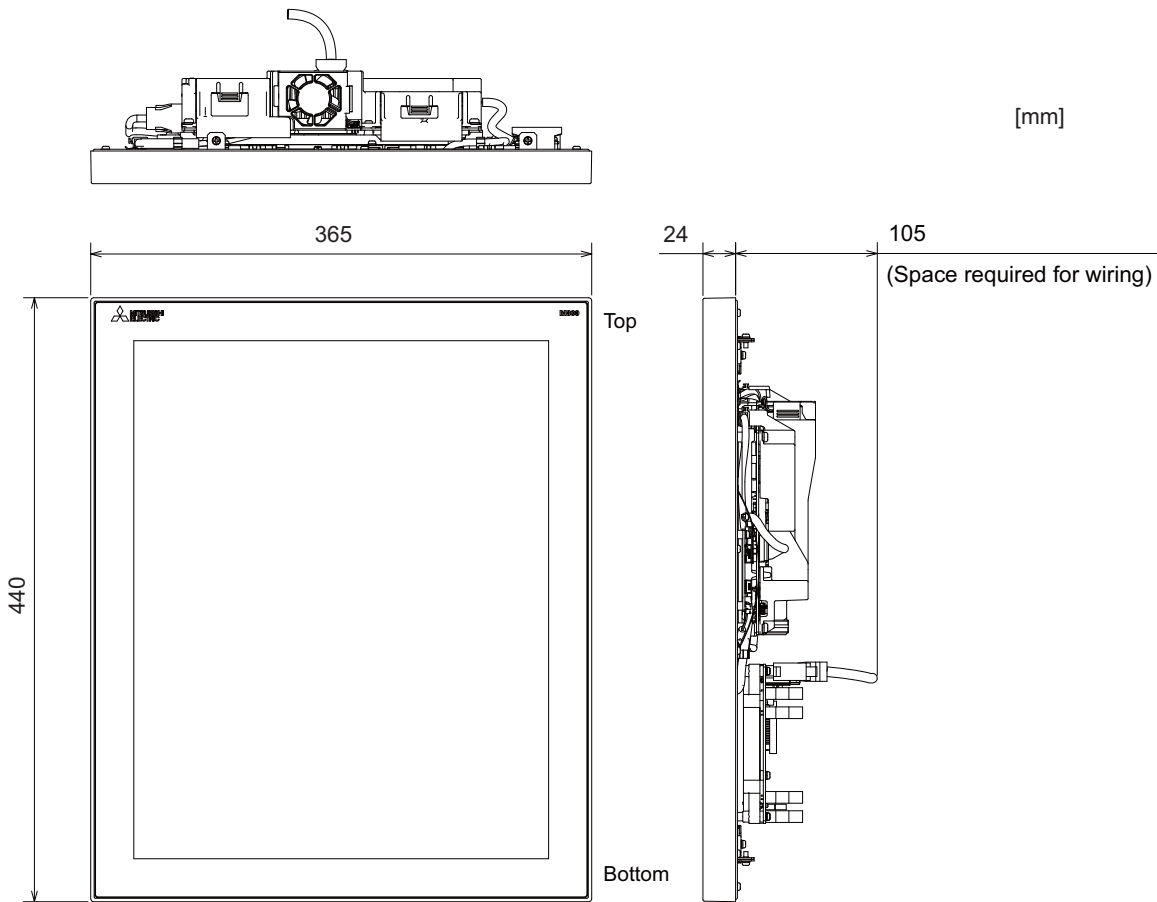

Note

(1) The figure above shows the state with the personal computer unit and the operation panel I/O unit mounted.

Panel cut dimensions

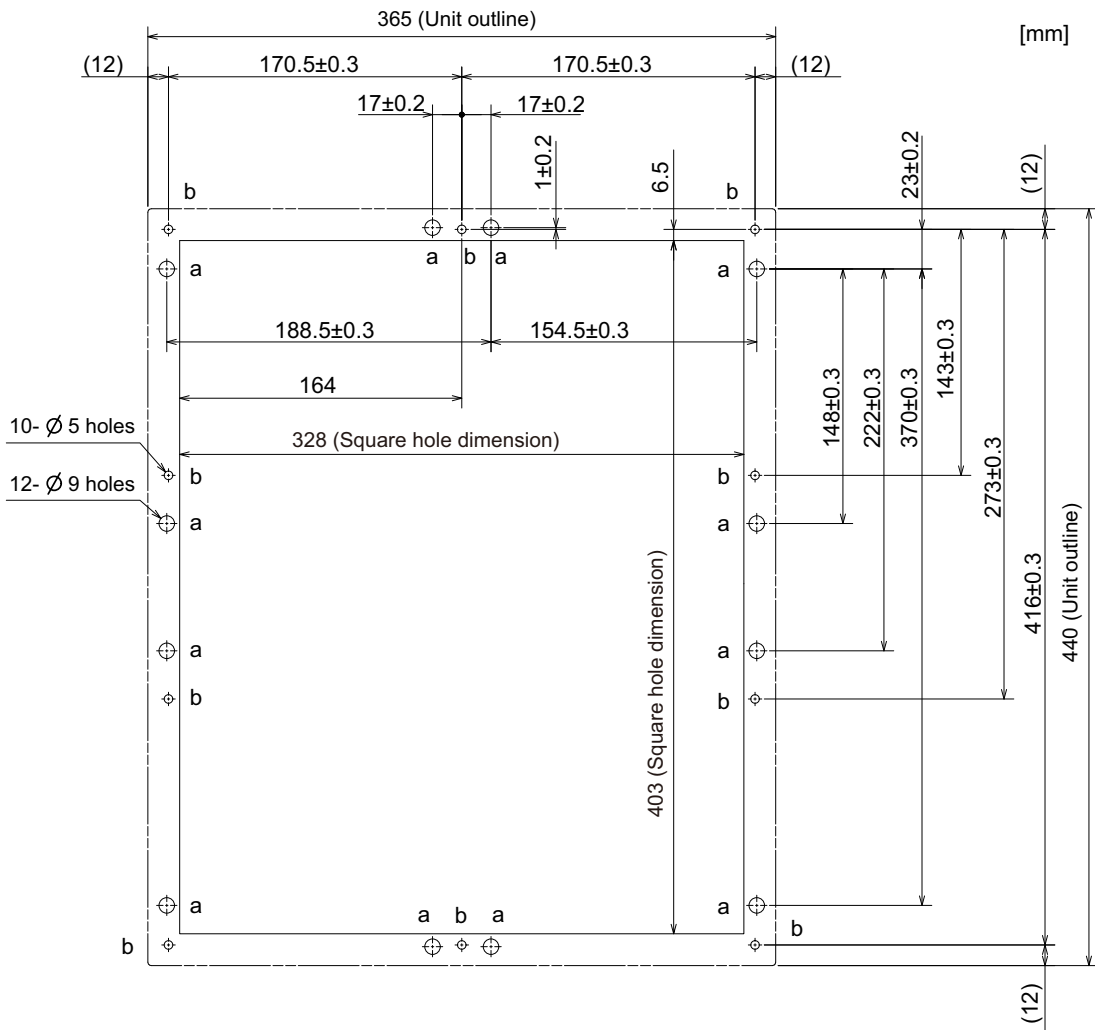

4.5.3 19-type (FCU8-DU194-75)

Outline dimensions

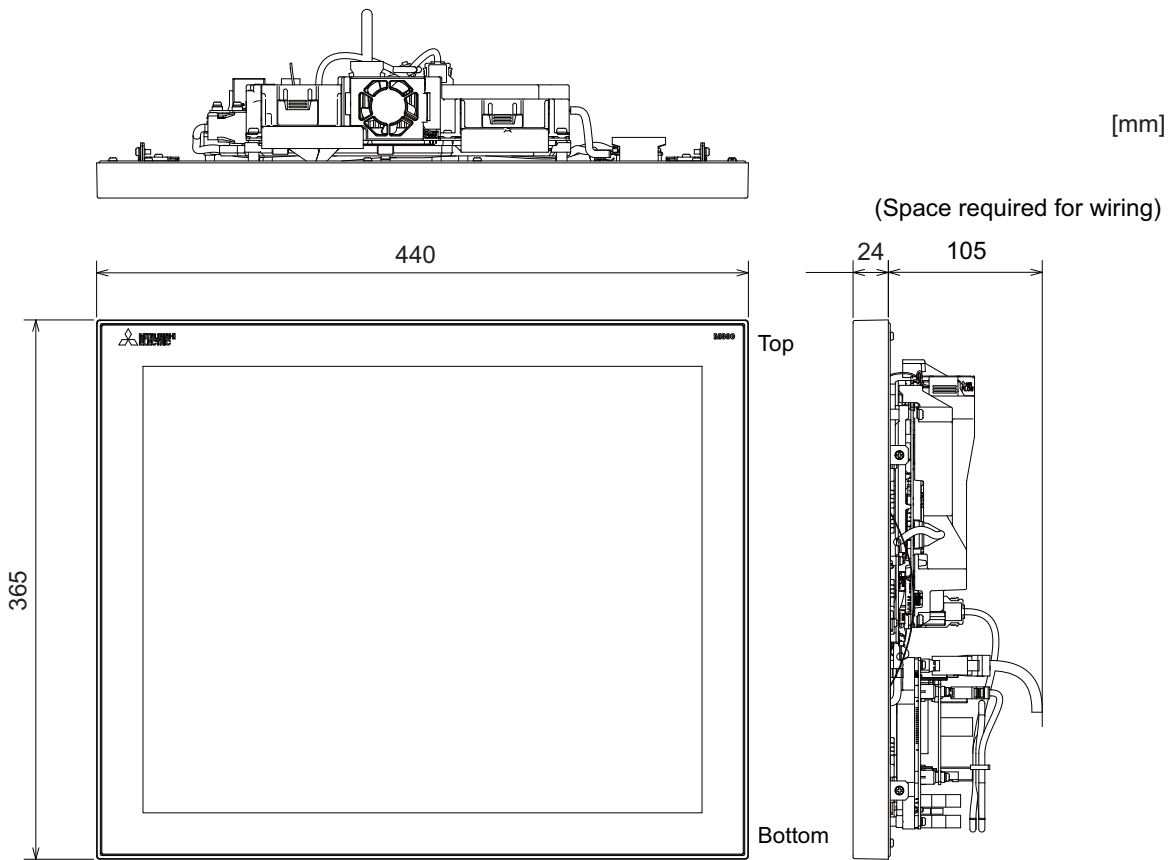

Note

- (1) The figure above shows the state with the personal computer unit and the operation panel I/O unit mounted.

Panel cut dimensions

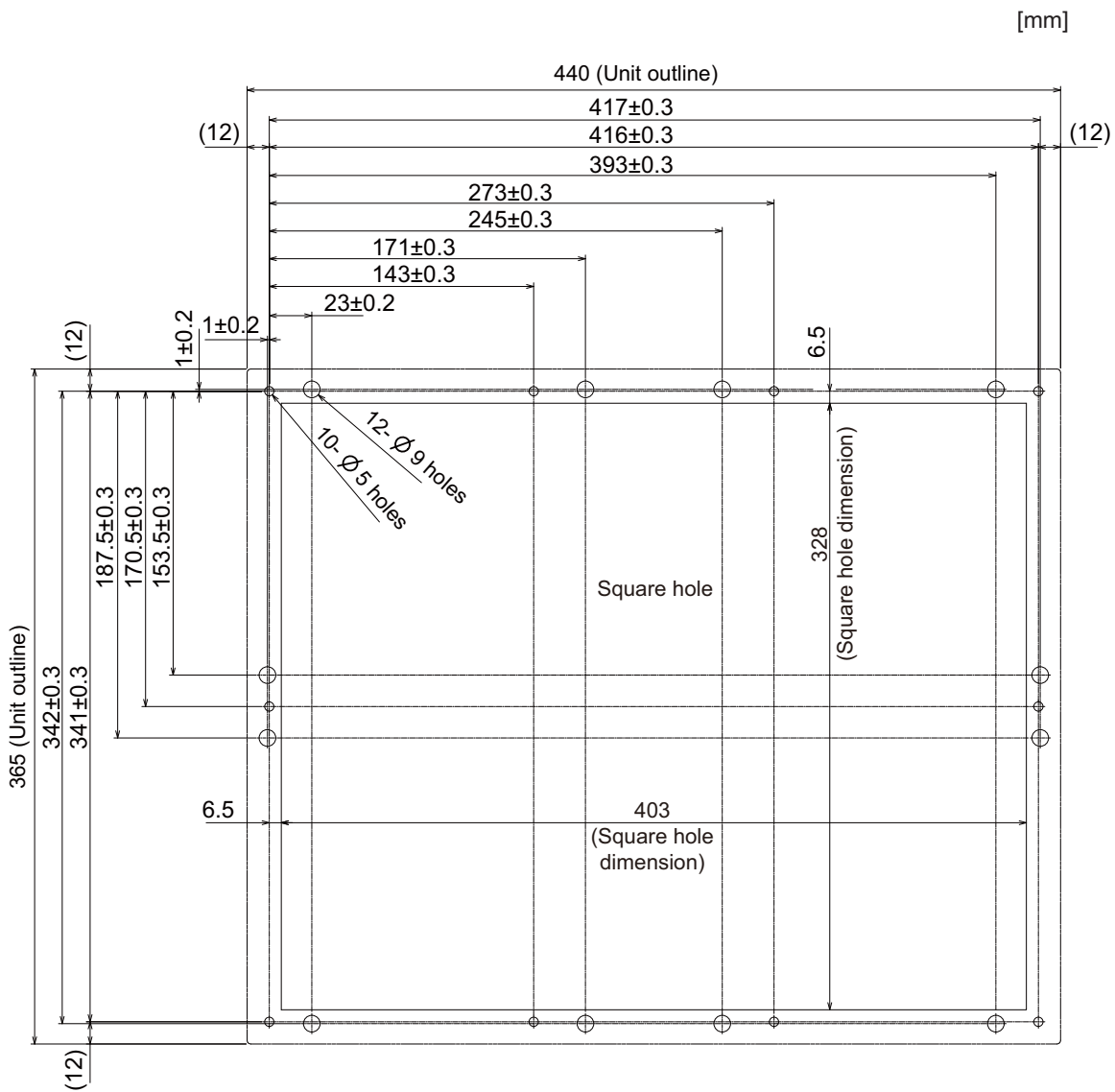

4.6 Display Unit [M80VW]

4.6.1 15-type (FCU8-DU182-36)

Outline dimensions

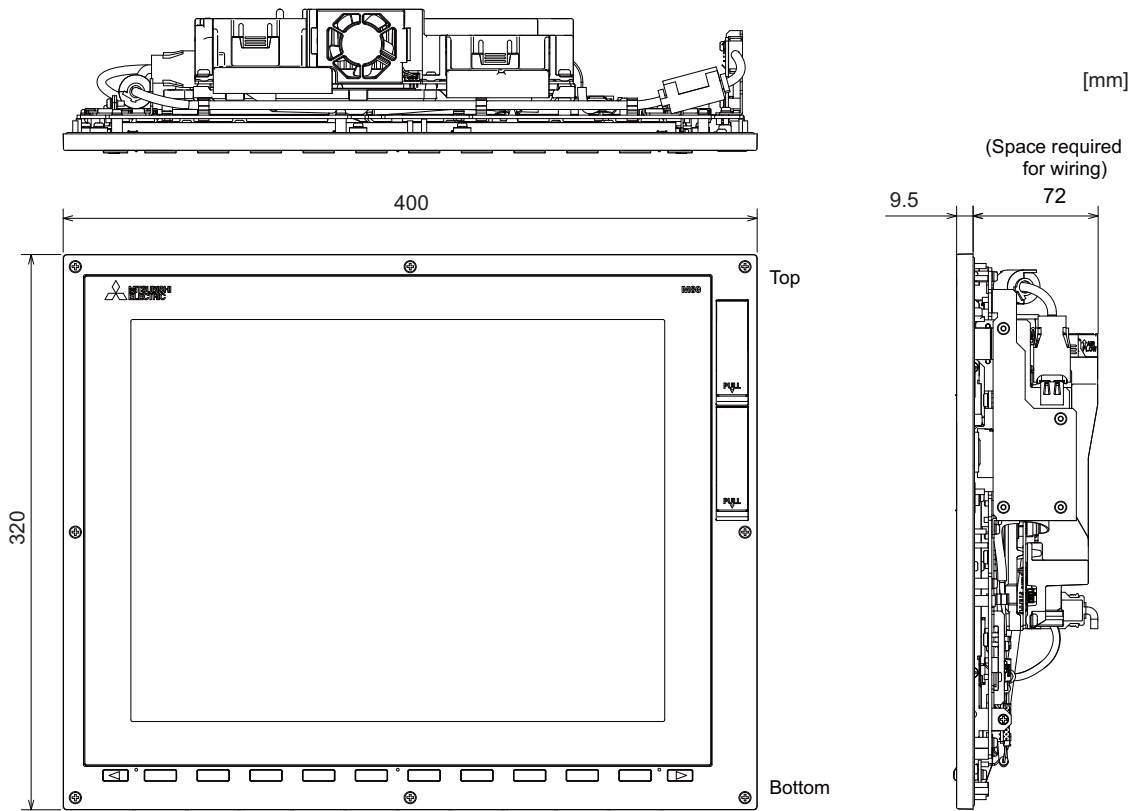

Note

(1) The figure above shows the state with the personal computer unit mounted.

Panel cut dimensions

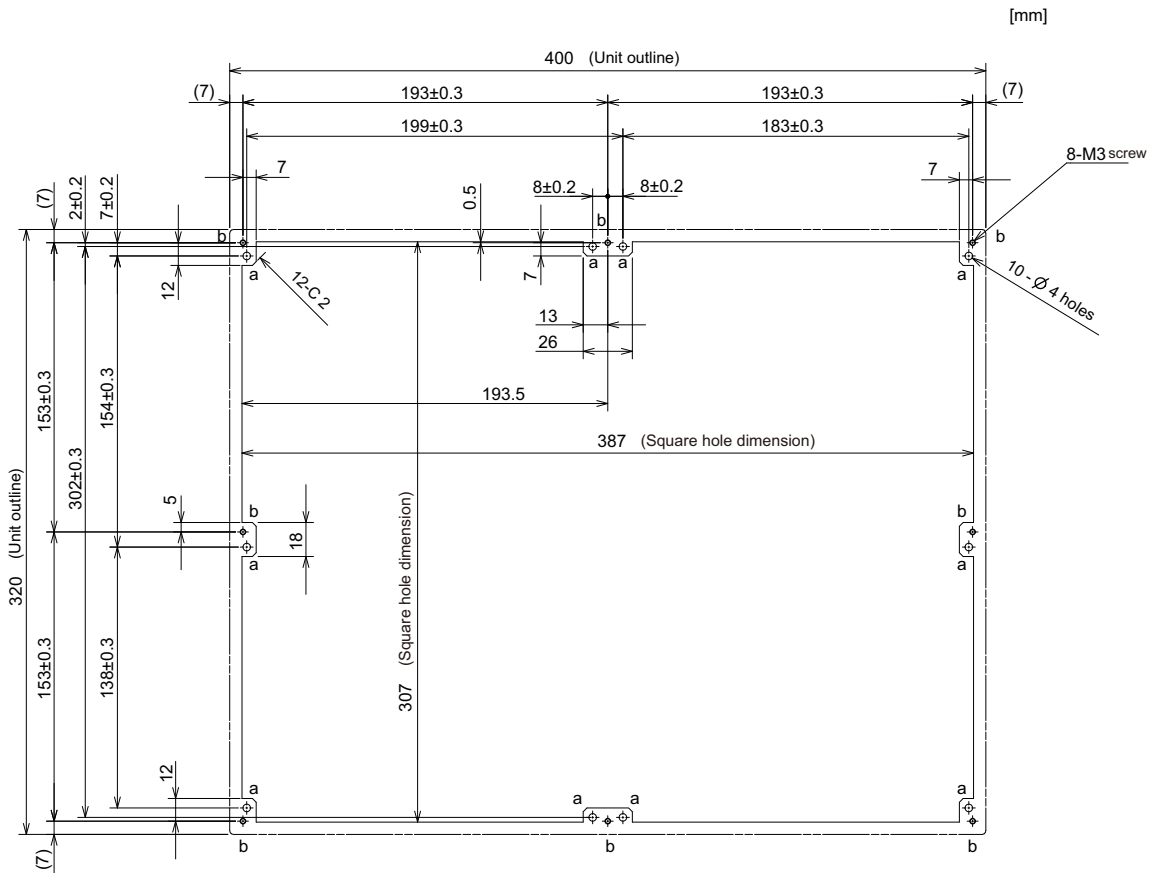

4.6.2 19-type (FCU8-DU193-77)

Outline dimensions

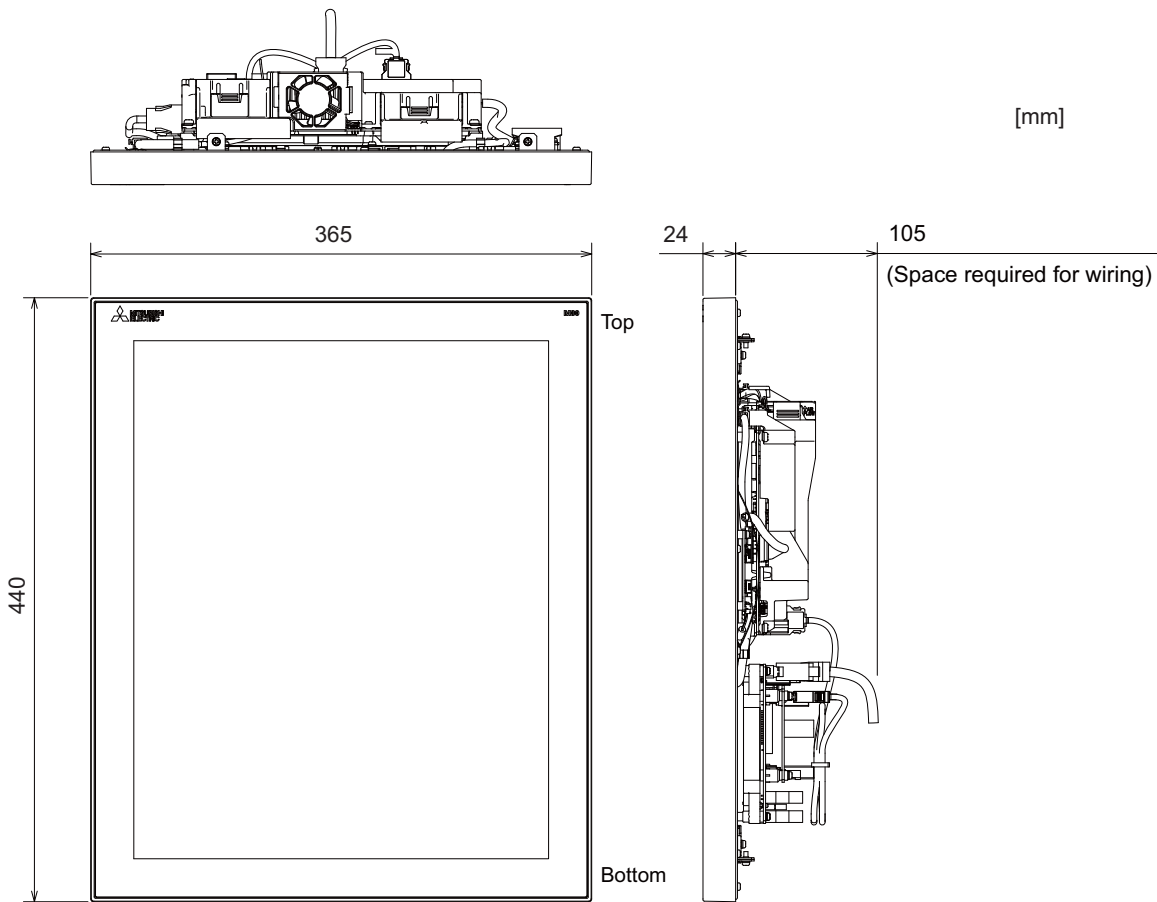

Note

(1) The figure above shows the state with the personal computer unit and the operation panel I/O unit mounted.

Panel cut dimensions

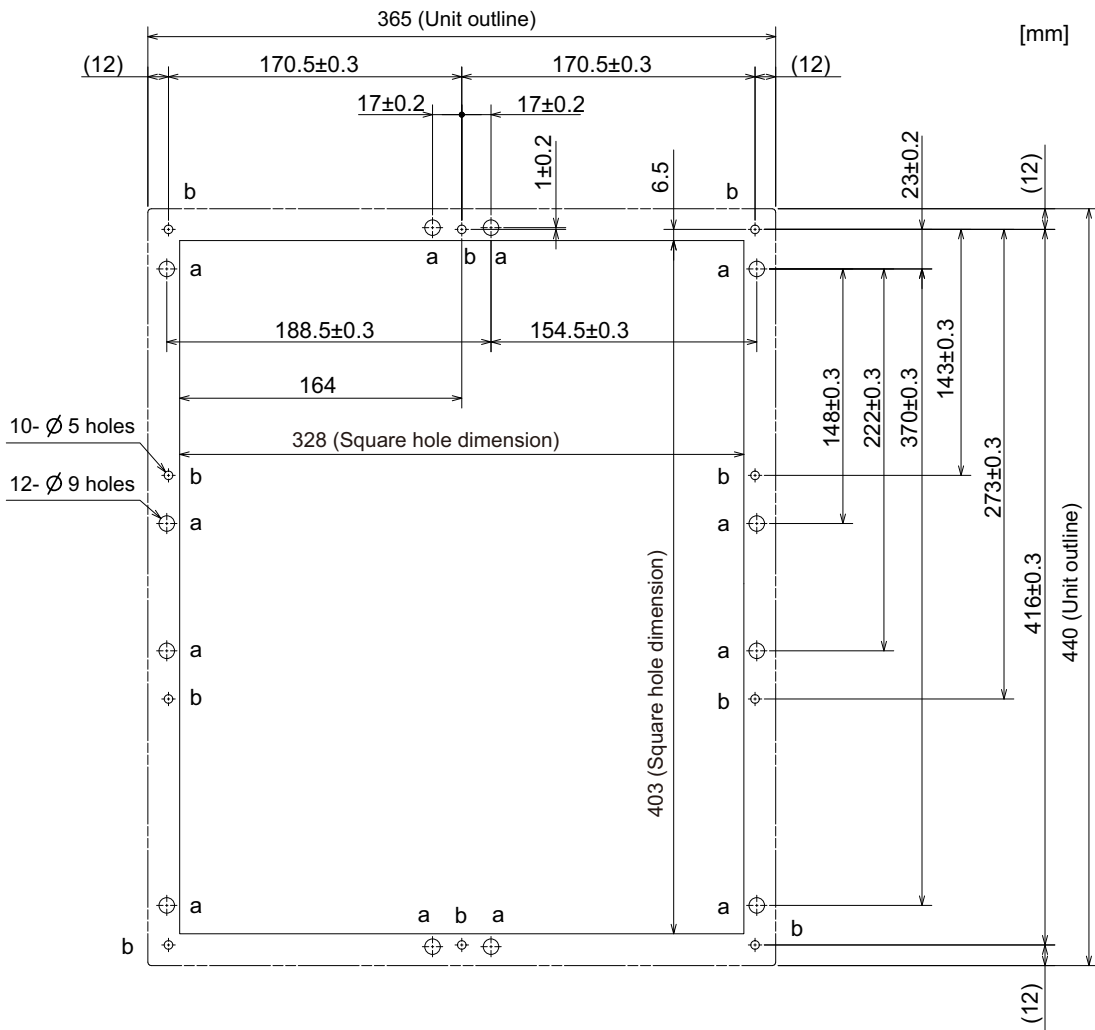

4.6.3 19-type (FCU8-DU194-77)

Outline dimensions

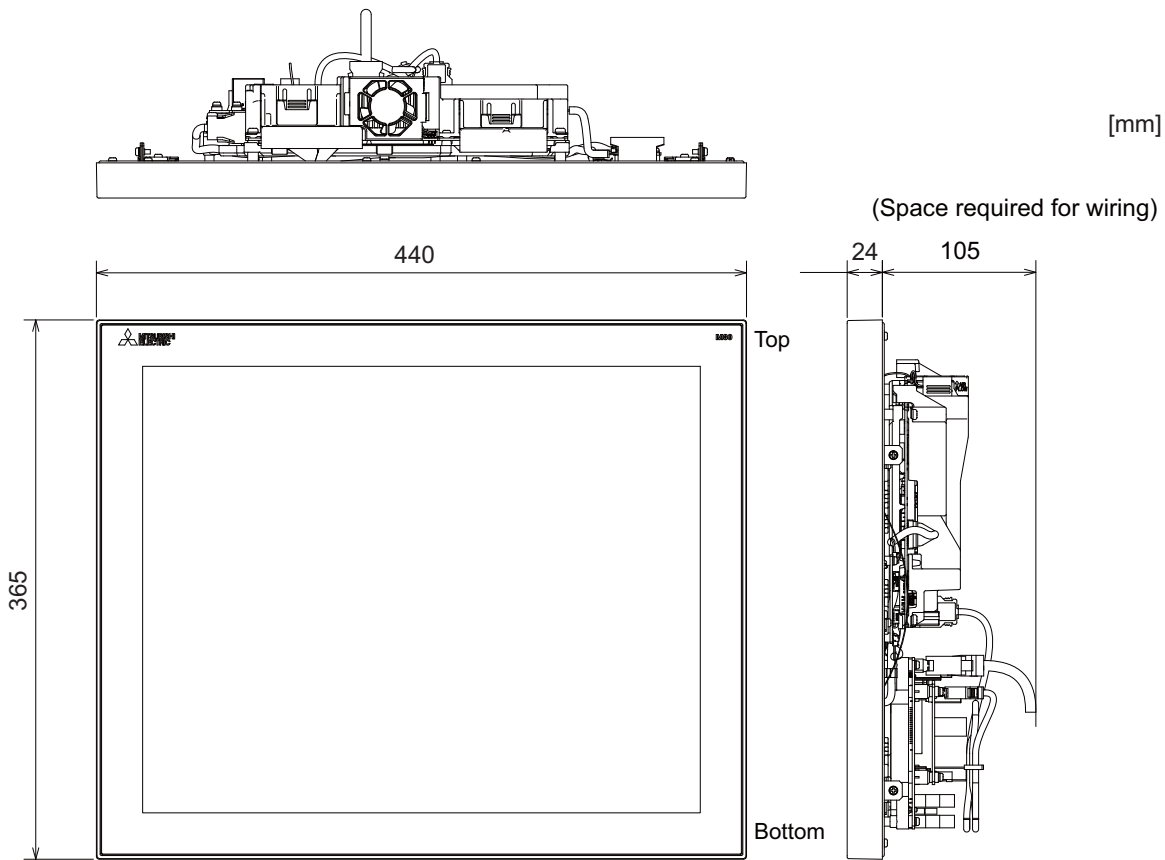

Note

(1) The figure above shows the state with the personal computer unit and the operation panel I/O unit mounted.

Panel cut dimensions

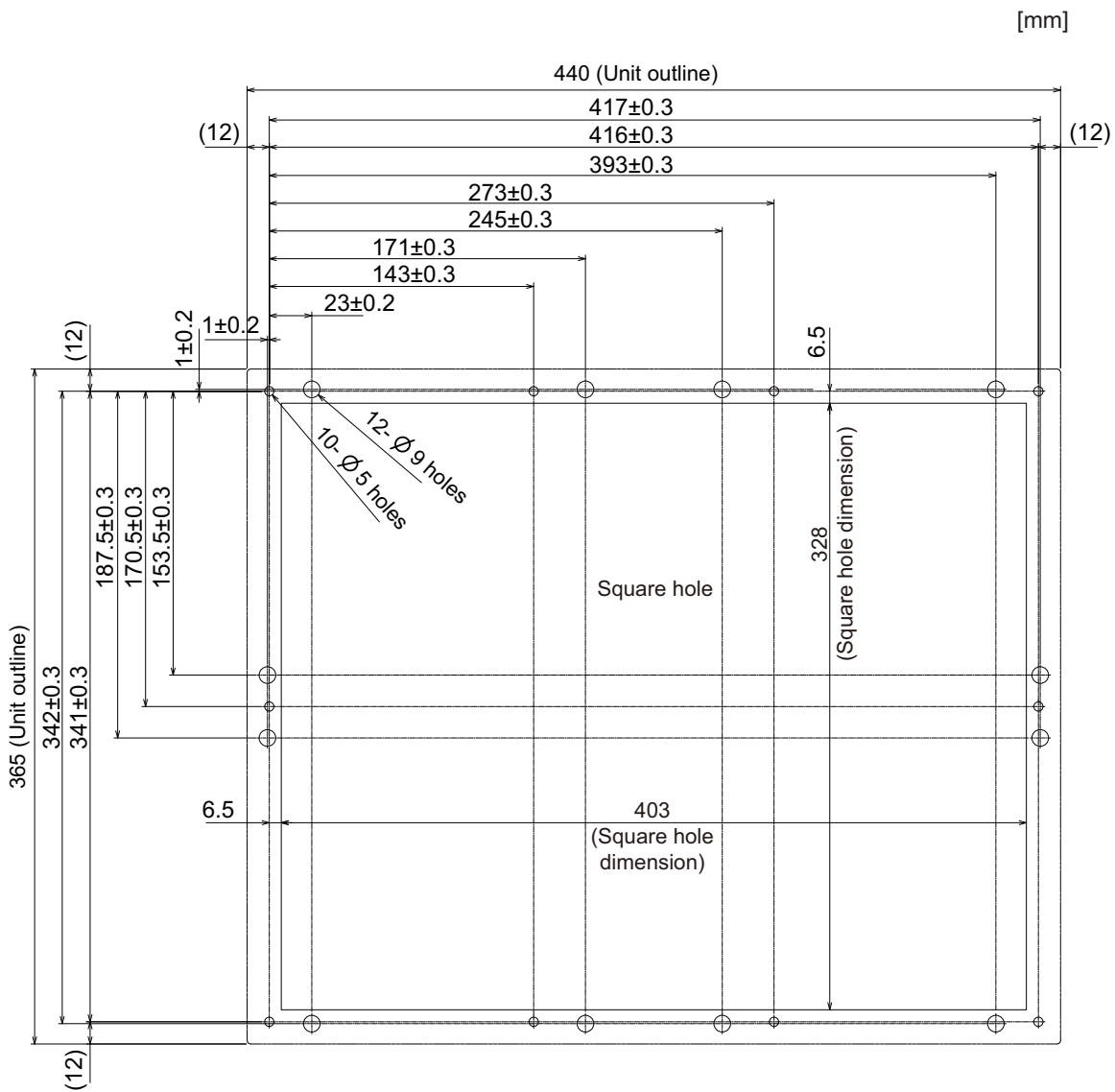

4.7 Personal Computer Unit

4.7.1 Personal Computer Unit (FCU8-PC232)

Outline dimensions

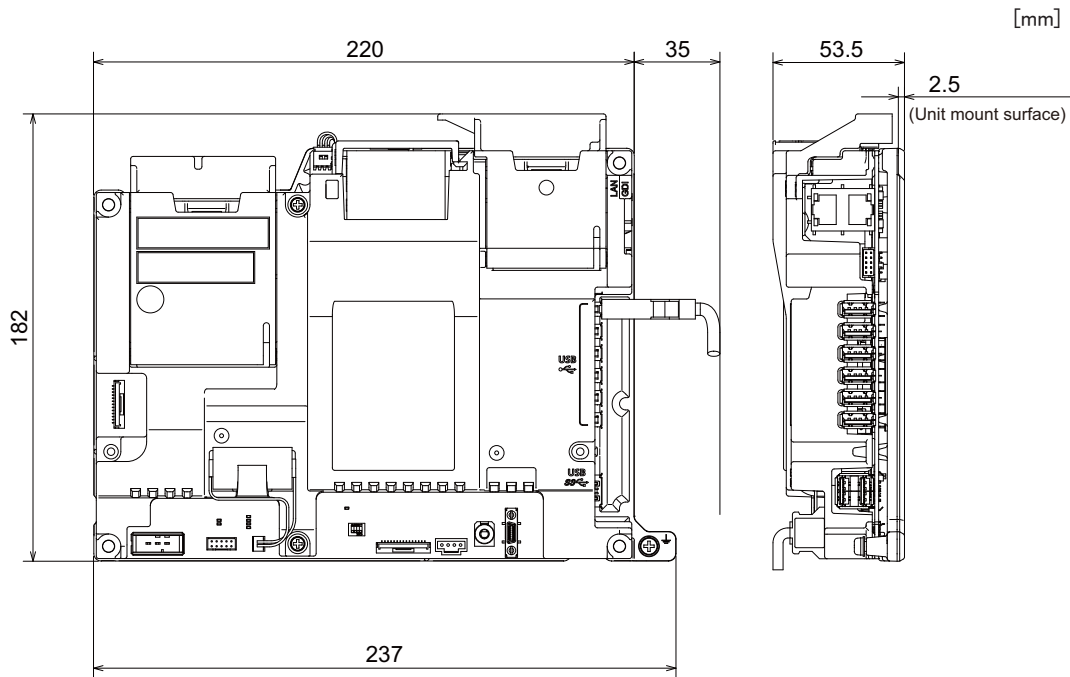

4.7.2 Built-in Disk of the Display Unit (FCU8-CF060G-1)

Outline dimensions

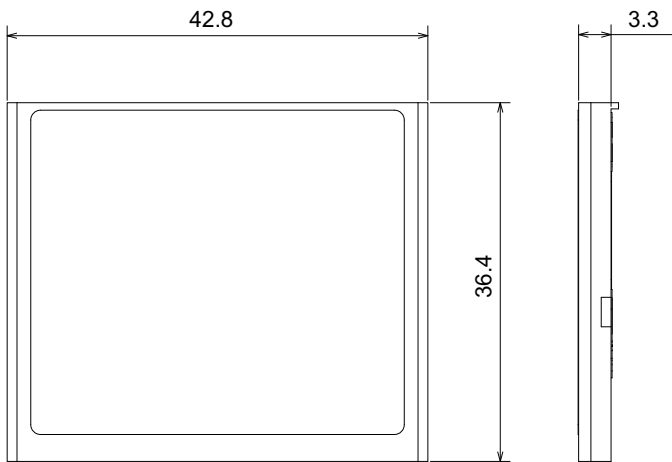

4.8 Keyboard Unit

Note

- (1) Do not change the setting for the rotary switch mounted on the keyboard unit. If the setting is changed, the keyboard will not work.

Type name	The initial value of the rotary switch
FCU8-KB083	A

4.8.1 Keyboard for 15-type Display Unit (FCU8-KB083)

Outline dimensions

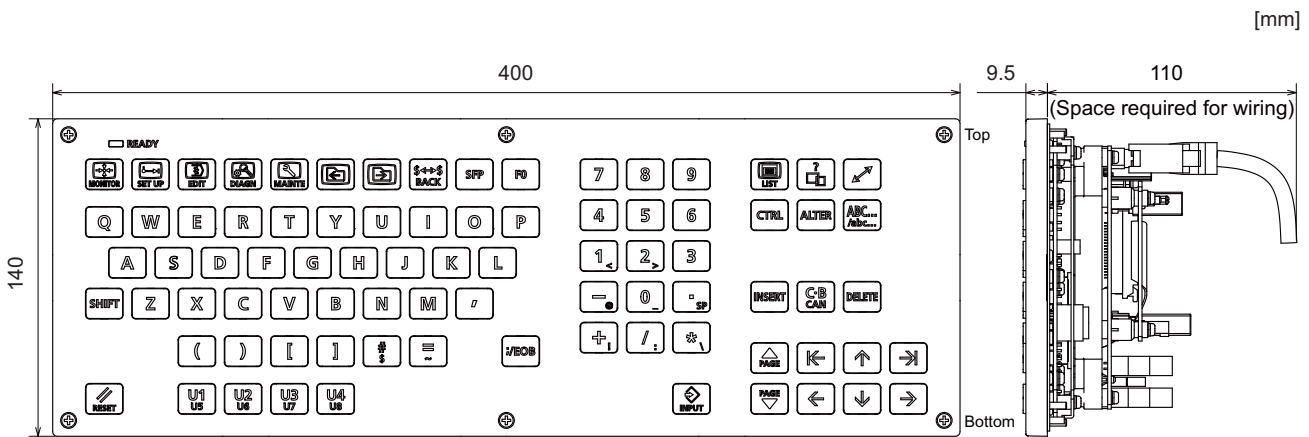

Note

- (1) The above side view shows the state with the operation panel I/O unit mounted.

Panel cut dimensions

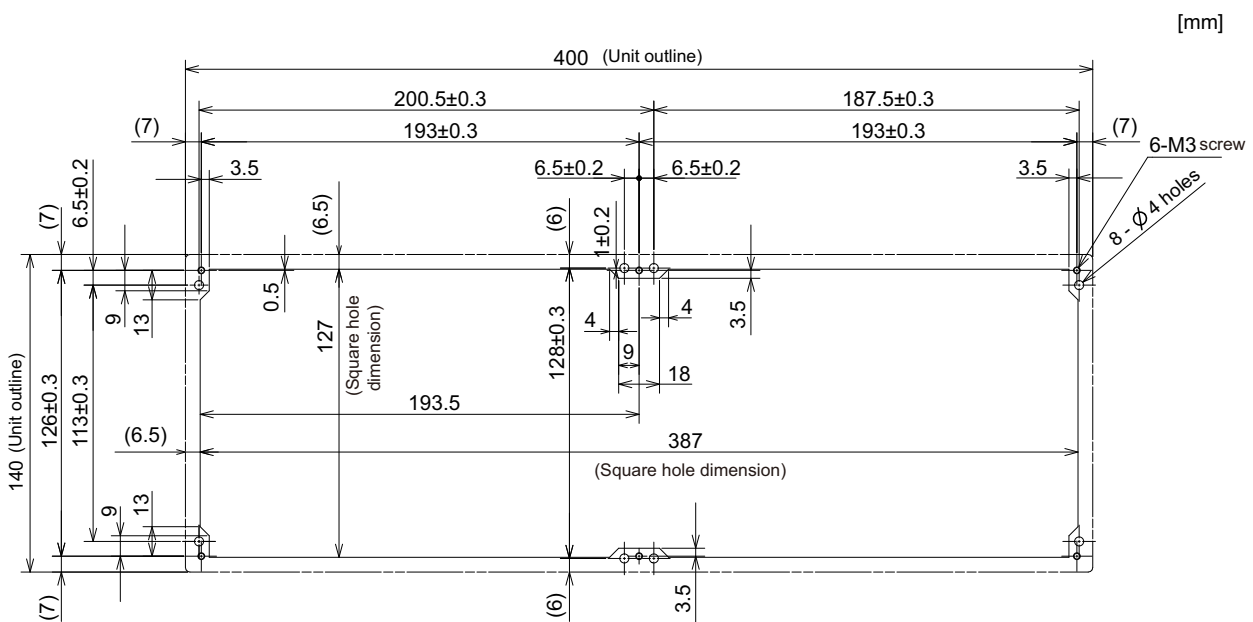

4.9 Operation Panel I/O Unit

4.9.1 List of Units

Classification	Type	Components	Remarks
DI 24 V/0 V common input [64 points] DO Source output [64 points]	FCU8-DX830	Base card Add-on card RIO 2.0 terminator connector (R2-TM)	DI: 64-point 24 V/0 V common type DO: 64-point source type (200 mA/point) Manual pulse generator input: 3ch Display unit I/F Keyboard unit I/F Emergency stop input Remote I/O 2.0 I/F RIO occupied stations (fixed): 1 to 4, 7 to 14, 20 to 22 RIO extensible stations: 5, 6, 15 to 19, 23 to 64 (*2)
DI 24 V/0 V common input [64 points] DO Source output [64 points] Scan input [64 points] Scan output [64 points]	FCU8-DX834 (*1)	Base card Add-on card RIO 2.0 terminator connector (R2-TM)	DI: 64-point 24 V/0 V common type DO: 64-point source type (200 mA/point) Scan input: 64 points Scan output: 64 points Manual pulse generator input: 3ch Display unit I/F Keyboard unit I/F Emergency stop input Remote I/O 2.0 I/F RIO occupied stations (fixed): 1 to 4, 7 to 14, 20 to 22 RIO extensible stations: 5, 6, 15 to 19, 23 to 64 (*2)
DI 24 V/0 V common input [64 points] DO Source output [64 points] Safety DI 24 V/0 V common input [8 points]	FCU8-DX837	Base card Add-on card RIO 2.0 terminator connector (R2-TM)	DI: 64-point 24 V/0 V common type DO: 64-point source type (200 mA/point) Safety DI: 8-point 0 V common type Manual pulse generator input: 3ch Display unit I/F Keyboard unit I/F Emergency stop input Remote I/O 2.0 I/F RIO occupied stations (fixed): 1 to 4, 7 to 14, 20 to 22 RIO extensible stations: 5, 6, 15 to 19, 23 to 64 (*2)

(*1) The connection method of DO (CG32/CG34) of FCU8-DX834 is different from other operation panel I/O units. Be careful not to connect to a wrong connector. See the descriptions mentioned in the later section for more specific explanation on connections.

(*2) J291 cable is required for connection with the personal computer unit. (for windows-based display)

4.9.2 FCU8-DX830/FCU8-DX834/FCU8-DX837

Outline dimensions: FCU8-DX830

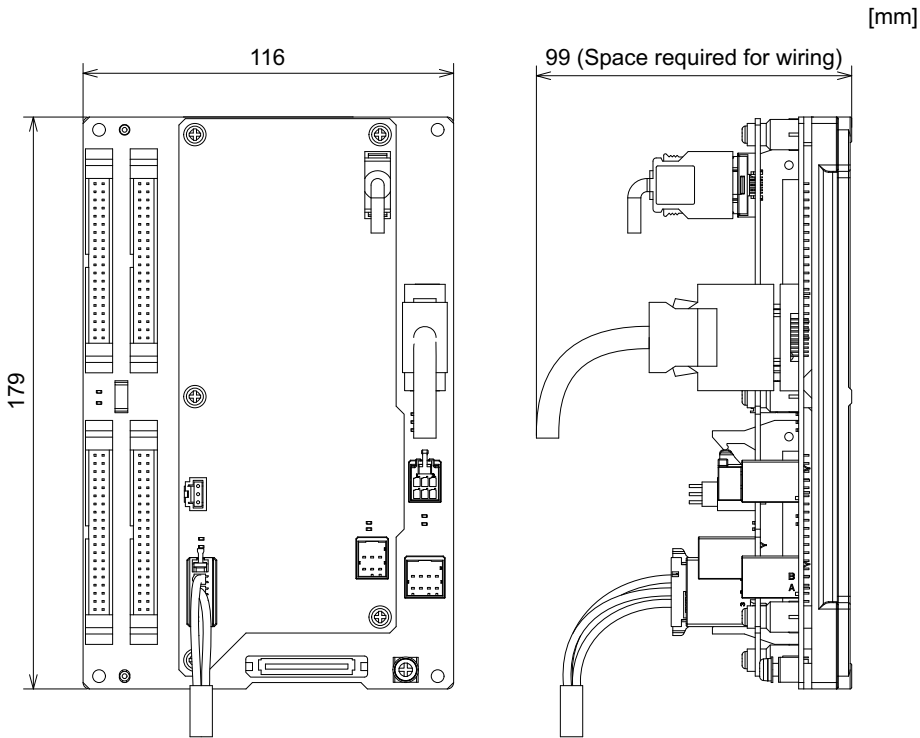

Outline dimensions: FCU8-DX834

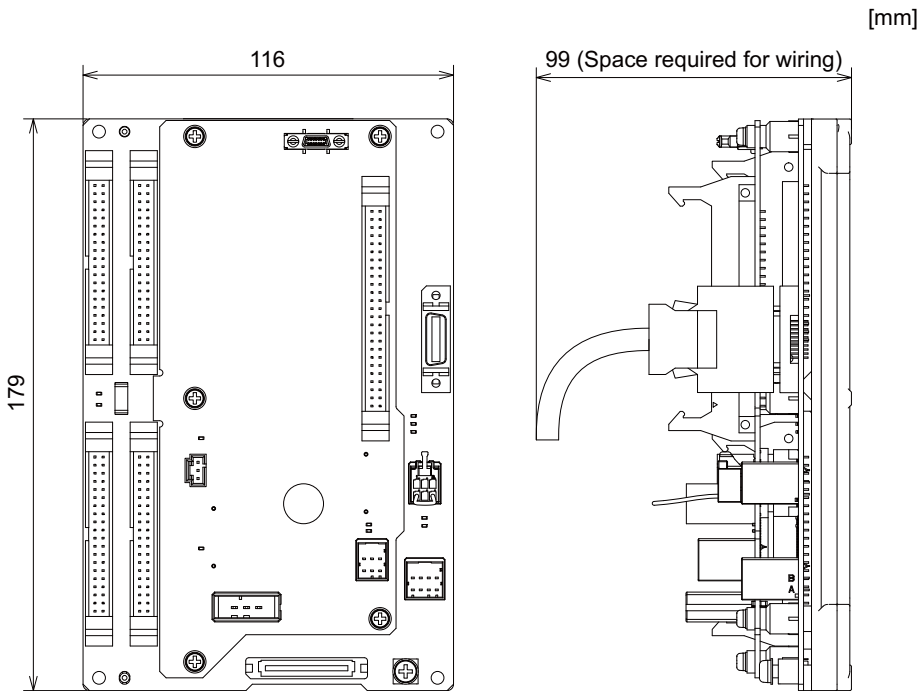

Outline dimensions: FCU8-DX837

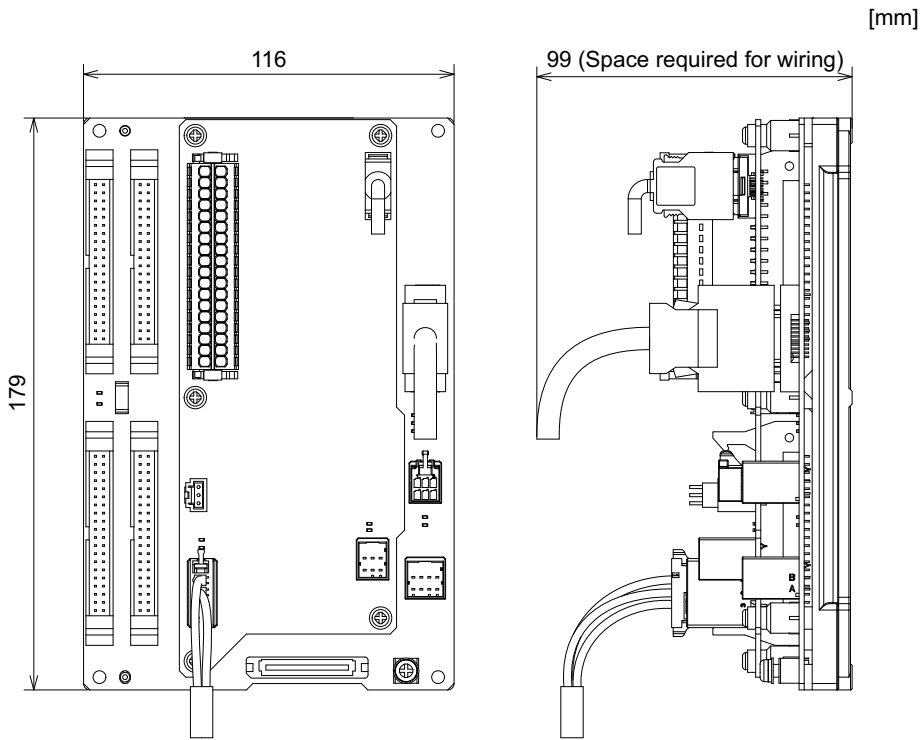

Installation dimensions: FCU8-DX830/FCU8-DX834/FCU8-DX837

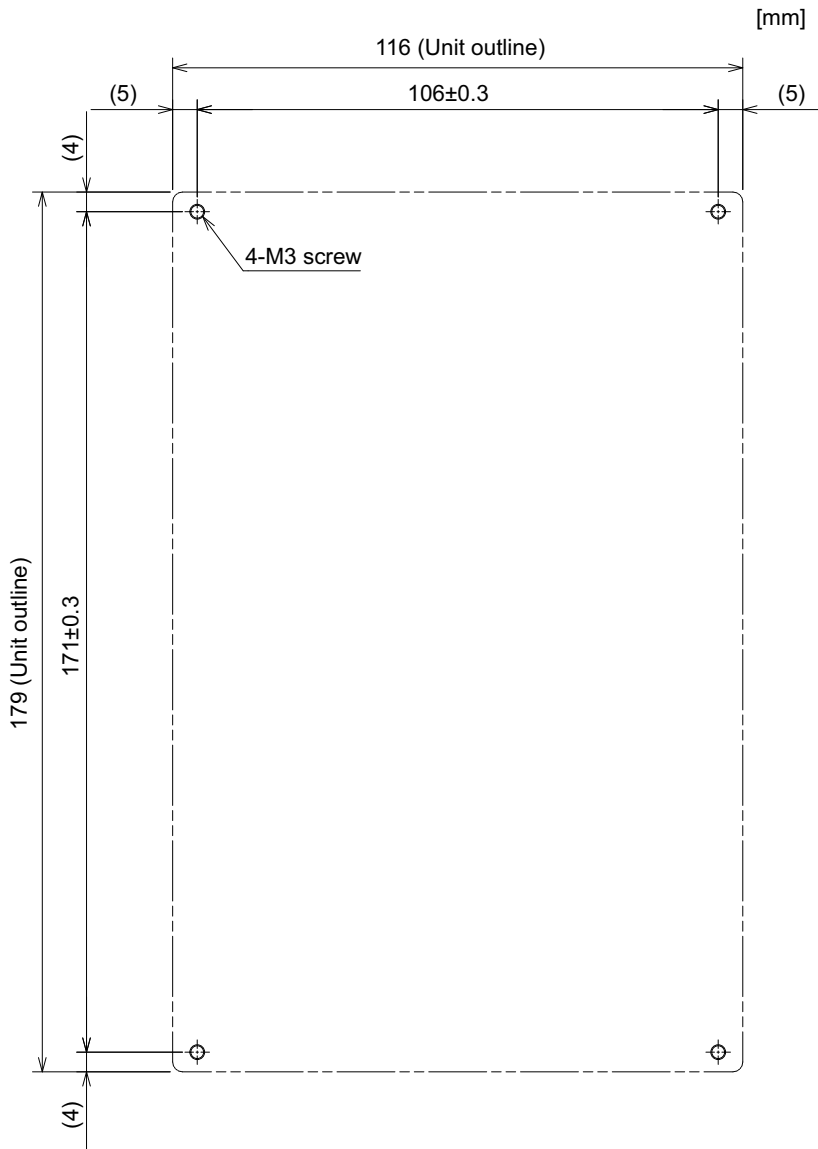

Note

- ♦ The unit thickness of the fixed part with screws is 16.6 mm.
Select the fixing screws having the length suitable for the thickness.

4.10 Remote I/O Unit

Types of signals described on the list of units can be input/output from the remote I/O unit (FCU8-DXxxx) according to the type and No. of contacts. Remote I/O units are used by being connected to the control unit or the operation panel I/O unit. Multiple remote I/O units can be used as long as the total number of occupied stations is 64 or less.

Note

(1) The maximum connectable number of remote I/O units is 32.

4.10.1 List of Units

Classification	Type	Components	Remarks
DI 24 V/0 V common input [32 points] DO Source output [32 points]	FCU8-DX220	Base card RIO 2.0 connector set	DI: 32-point 24 V/0 V common type DO: 32-point source type (200 mA/point) Number of occupied stations: 1
DI 24 V/0 V common input [64 points] DO Source output [48 points]	FCU8-DX230	Base card RIO 2.0 connector set	DI: 64-point 24 V/0 V common type DO: 48-point source type (200 mA/point) Number of occupied stations: 2
DI 24 V/0 V common input [64 points] DO Source output [48 points] AO analog output [1 point]	FCU8-DX231	Base card RIO 2.0 connector set	DI: 64-point 24 V/0 V common type DO Source type [48 points] (200 mA/point) AO: 1 point Number of occupied stations: 2
AI analog input [4 points] AO analog output [1 point]	FCU8-DX202	Base card RIO 2.0 connector set	AI: 4 points AO: 1 point Number of occupied stations: 1
DI 0 V common input [16 points] DO Source output (large capacity) [8 points]	FCU8-DX213	Base card RIO 2.0 connector set	DI: 16-point 0 V common type (3 mA/point) DO: 8-point source type (2 A/point) Number of occupied stations: 1
DI 0 V common input [16 points] DO Source output (large capacity) [8 points]	FCU8-DX213-1	Base card RIO 2.0 connector set	DI: 16-point 0 V common type (9 mA/point) DO: 8-point source type (2 A/point) Number of occupied stations: 1
Safety DI 0 V common input [8 points] Safety DO Source output (large capacity) [4 points]	FCU8-DX654	Base card RIO 2.0 connector set	Safety DI: 8-point 0 V common type (3 mA/point) Safety DO: 4-point source type (2 A/point) Number of occupied stations: 2
Safety DI 0 V common input [8 points] Safety DO Source output (large capacity) [4 points]	FCU8-DX654-1	Base card RIO 2.0 connector set	Safety DI: 8-point 0 V common type (9 mA/point) Safety DO: 4-point source type (2 A/point) Number of occupied stations: 2
DI 24 V/0 V common input [32 points] DO Source output [32 points] Safety DI 0V common input [8 points] (*1) Safety relay output [4 points] (*2)	FCU8-DX651	Base card Add-on card RIO 2.0 connector set	DI: 24 V/0 V common type [32 points] DO: 32-point source type (200 mA/point) Safety DI: 8-point 0 V common type Safety relay: 4 points (non-voltage contact) Relay contact welding detection Number of occupied stations: 3
Thermistor input (12 points)	FCU8-DX408	Base card RIO 2.0 connector set	Thermistor input: 12 points Number of occupied stations: 3
Multi-analog input [4 points] (*3)	FCU8-DX409	Base card RIO 2.0 connector set	Multi-analog input: 4 points Number of occupied stations: 4

(*1) Safety DI uses 16 points of terminal because of the duplication wiring.

(*2) Safety relay output uses 8 points of terminal because of the duplication wiring.

(*3) Voltage input, current input, thermocouple input and resistance temperature detector input are selected for each CH.

4.10.2 FCU8-DX220/FCU8-DX230/FCU8-DX231/FCU8-DX202/FCU8-DX213/ FCU8-DX213-1/FCU8-DX654/FCU8-DX654-1/FCU8-DX651/FCU8-DX408/ FCU8-DX409

Outline dimensions: FCU8-DX220

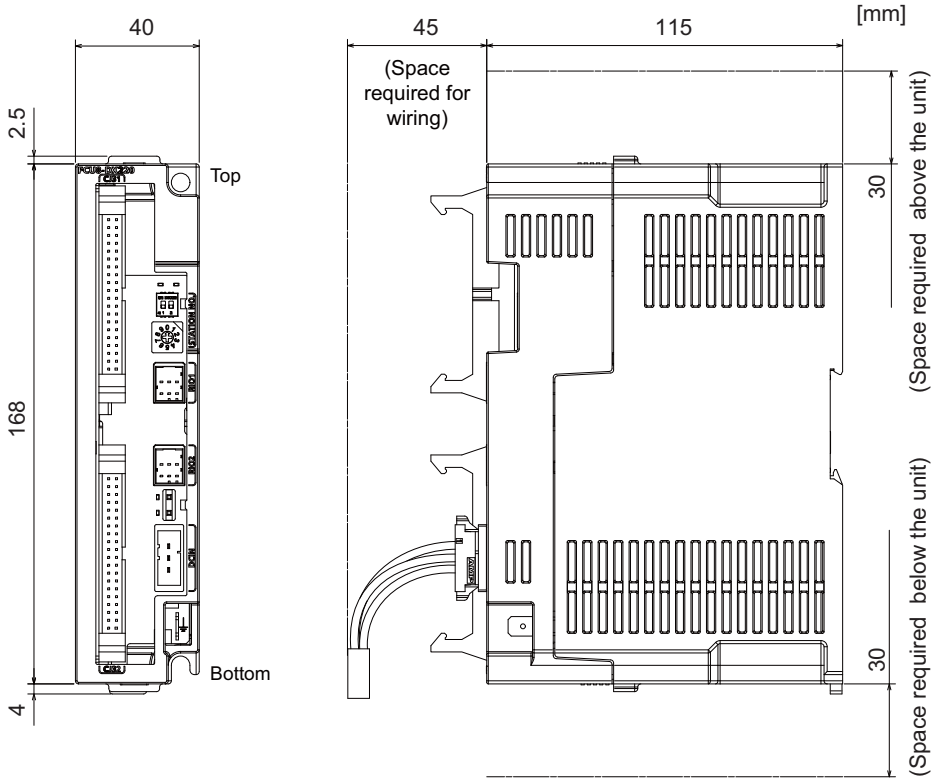

Outline dimensions: FCU8-DX230

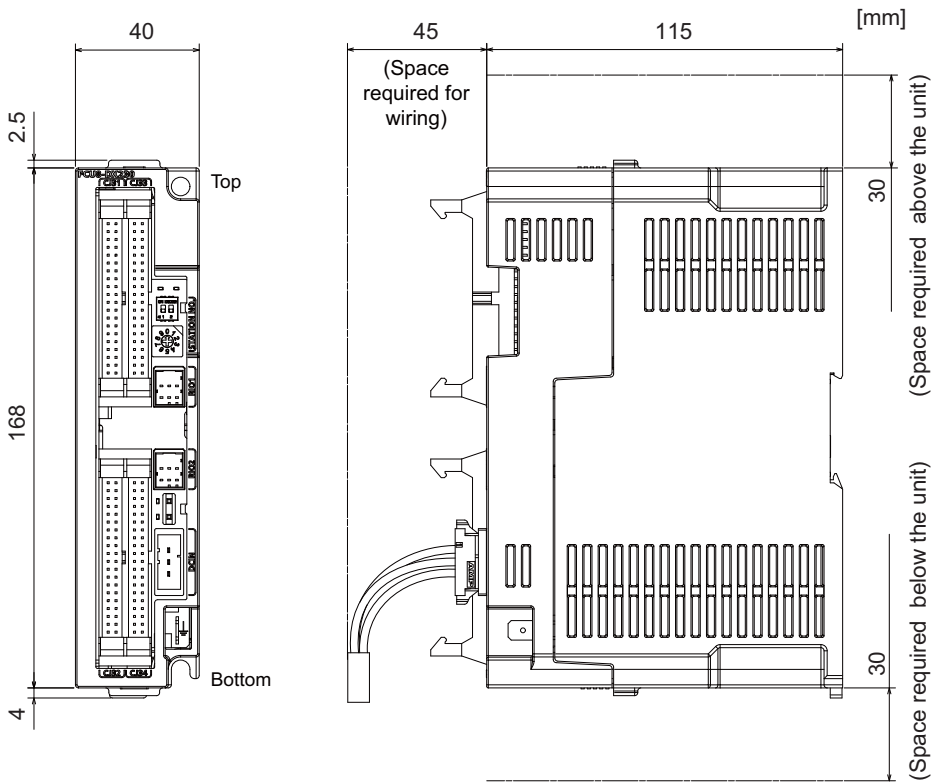

Outline dimensions: FCU8-DX231

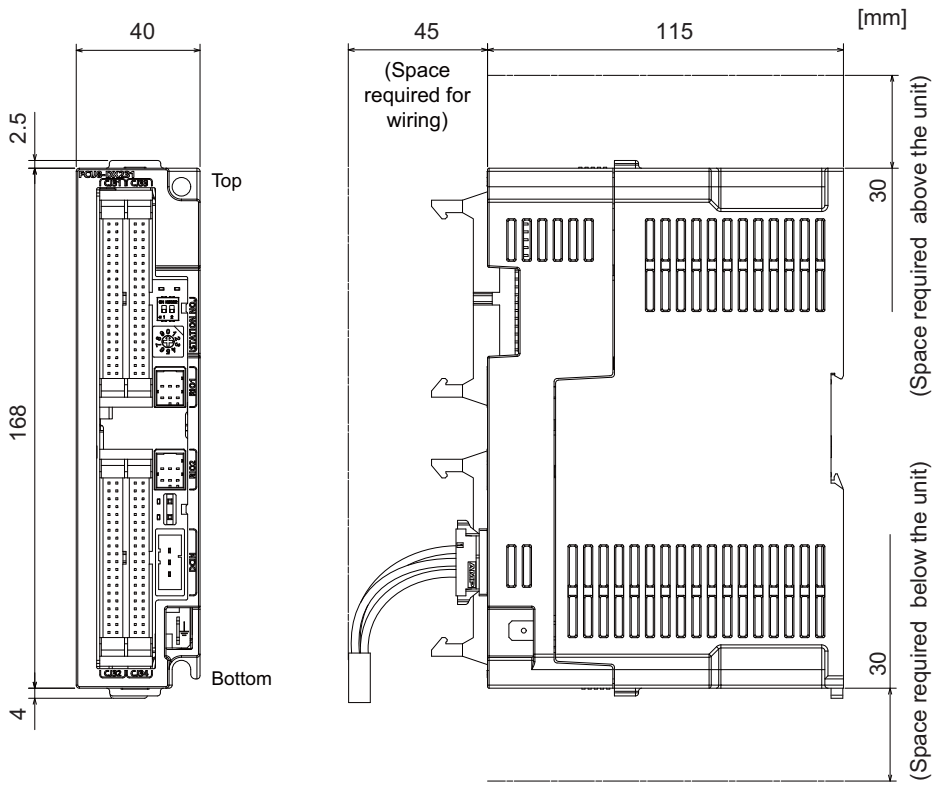

Outline dimensions: FCU8-DX202

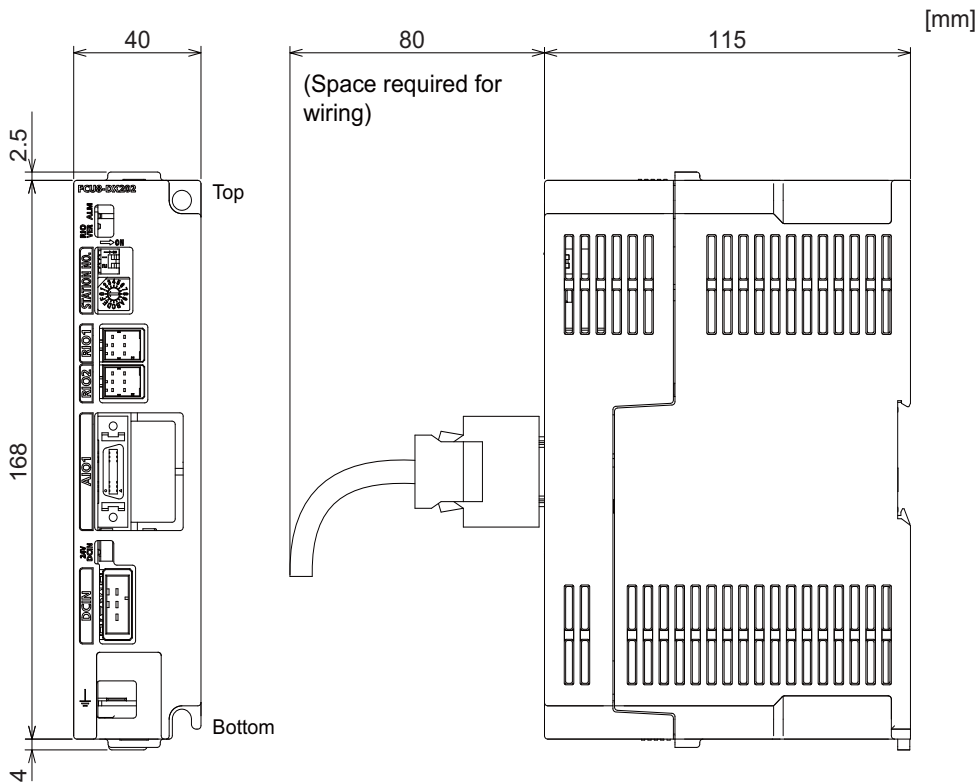

Outline dimensions: FCU8-DX213

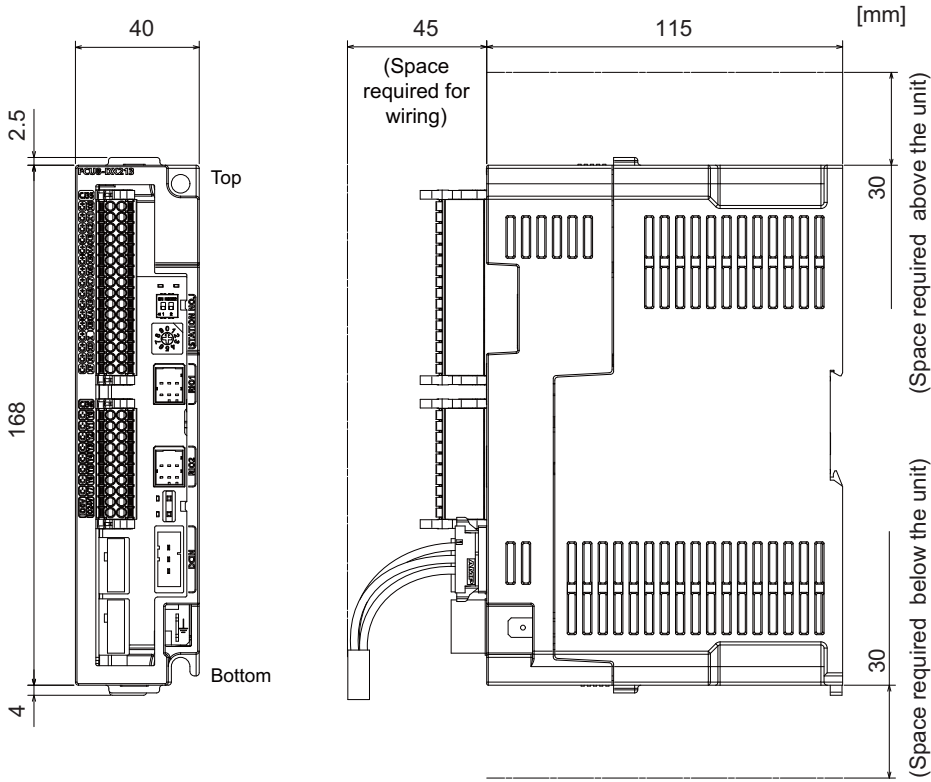

Outline dimensions: FCU8-DX213-1

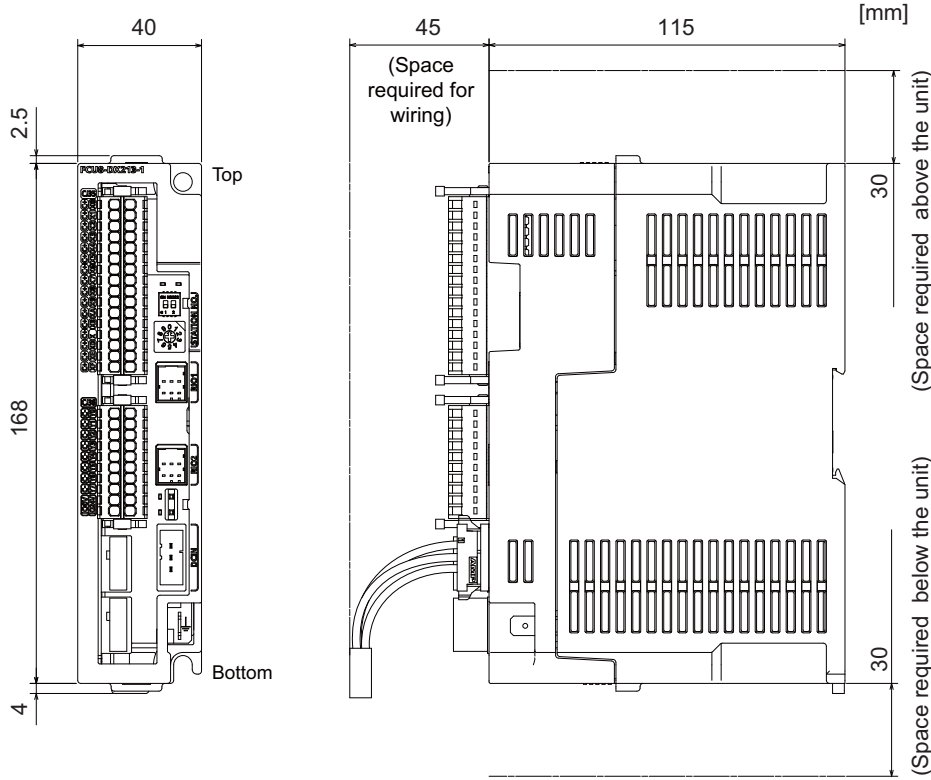

Outline dimensions: FCU8-DX654

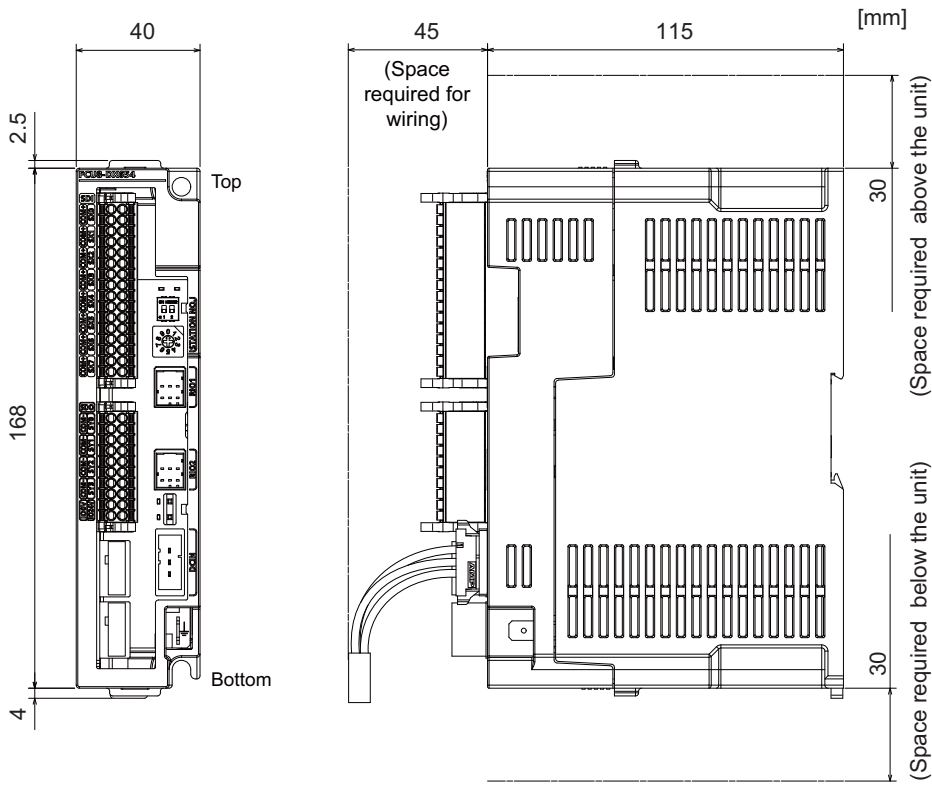

Outline dimensions: FCU8-DX654-1

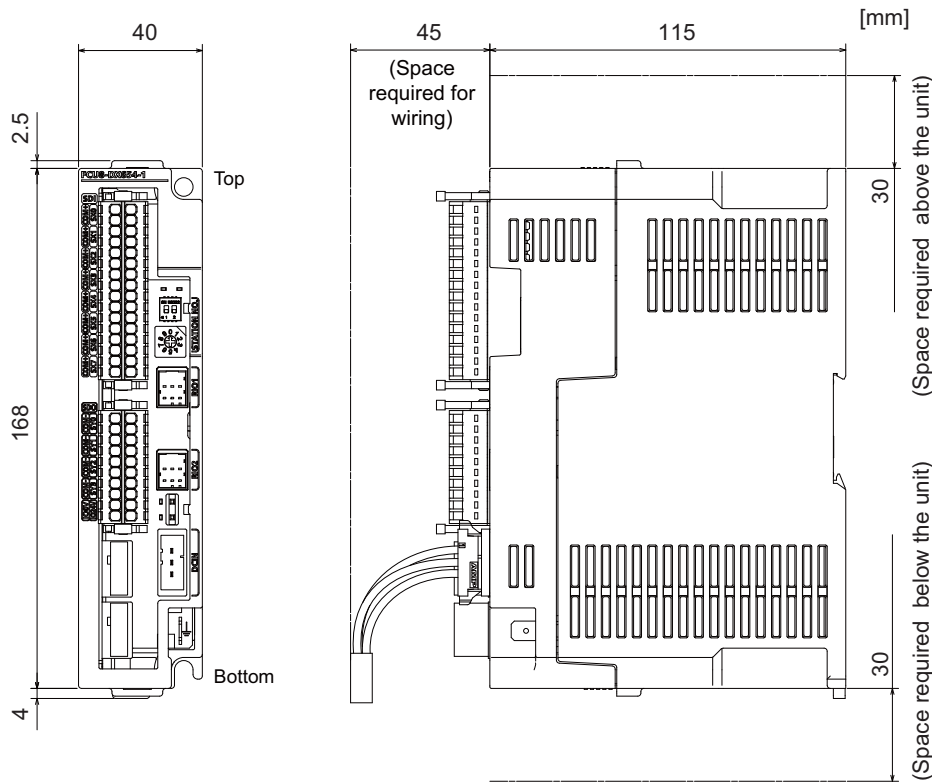

Outline dimensions: FCU8-DX651

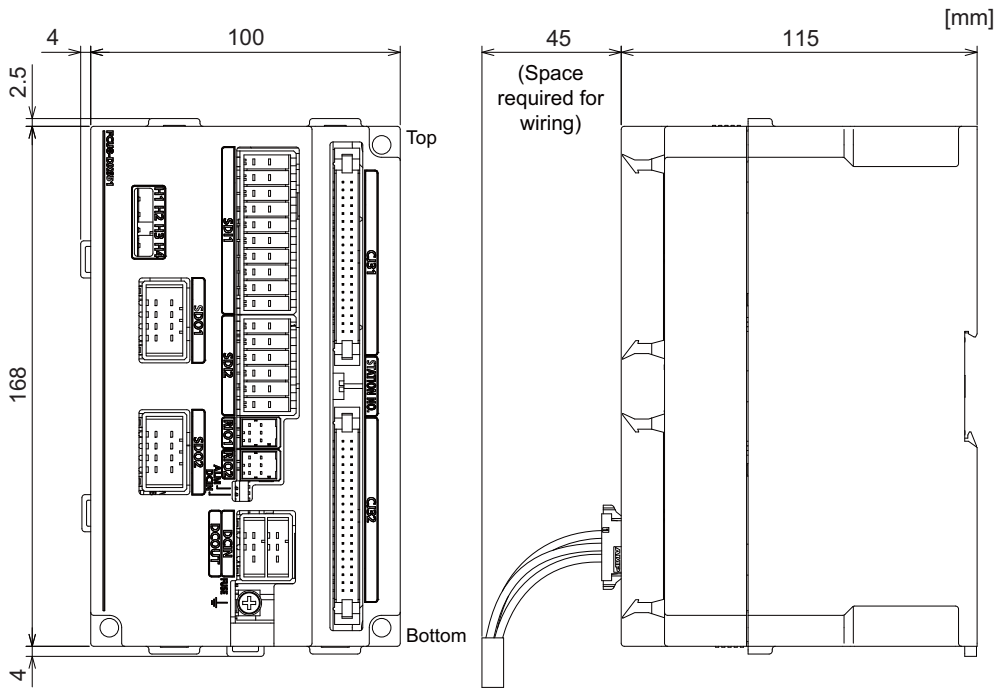

Outline dimensions: FCU8-DX408

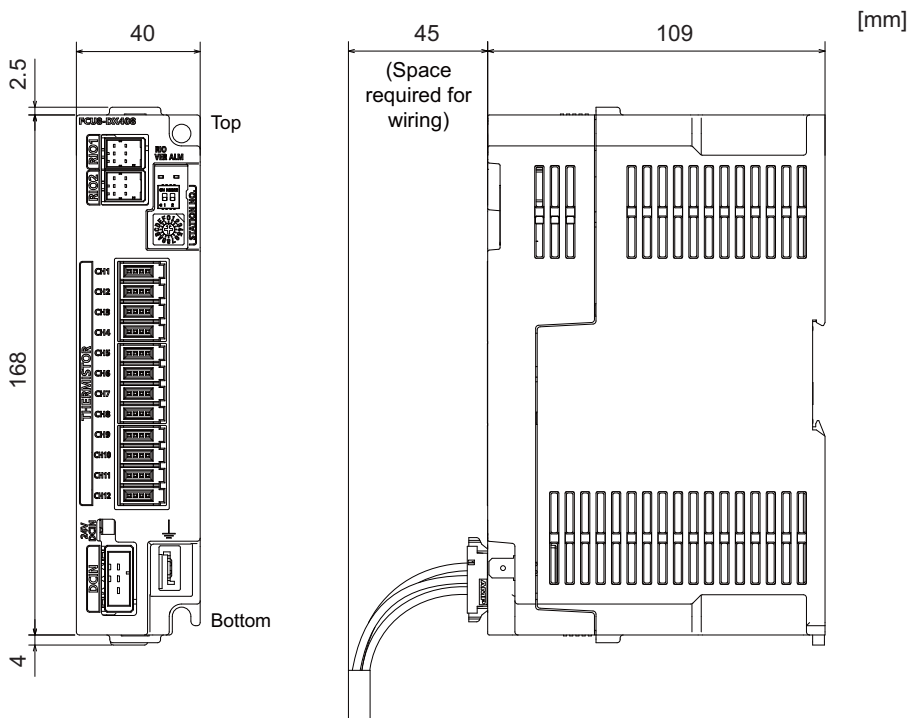

**Installation dimensions: FCU8-DX220/FCU8-DX230/FCU8-DX231/FCU8-DX202/FCU8-DX213/
FCU8-DX213-1/FCU8-DX654/FCU8-DX654-1/FCU8-DX408/FCU8-DX409**

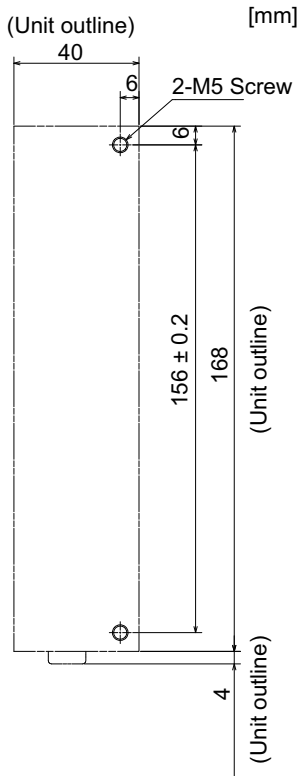

Installation dimensions: FCU8-DX651

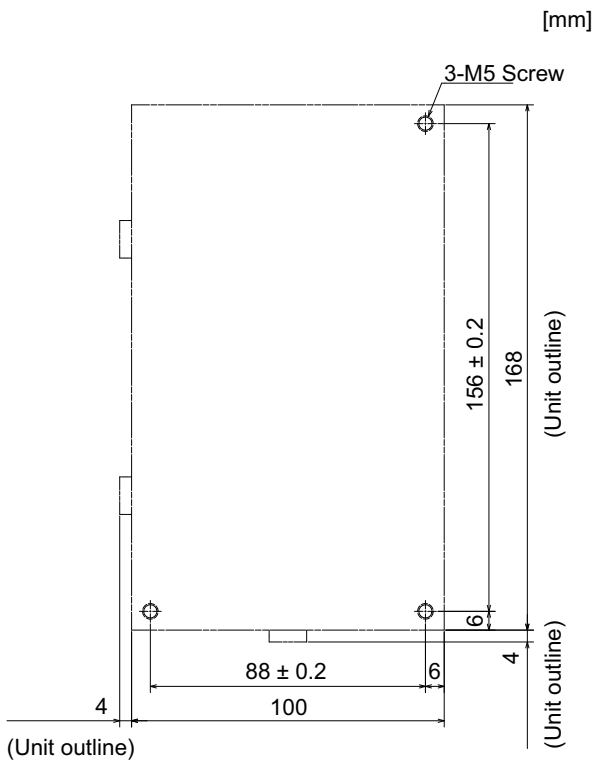

4.11 Laser I/F Unit

4.11.1 FCU8-DX522-001

Outline dimensions

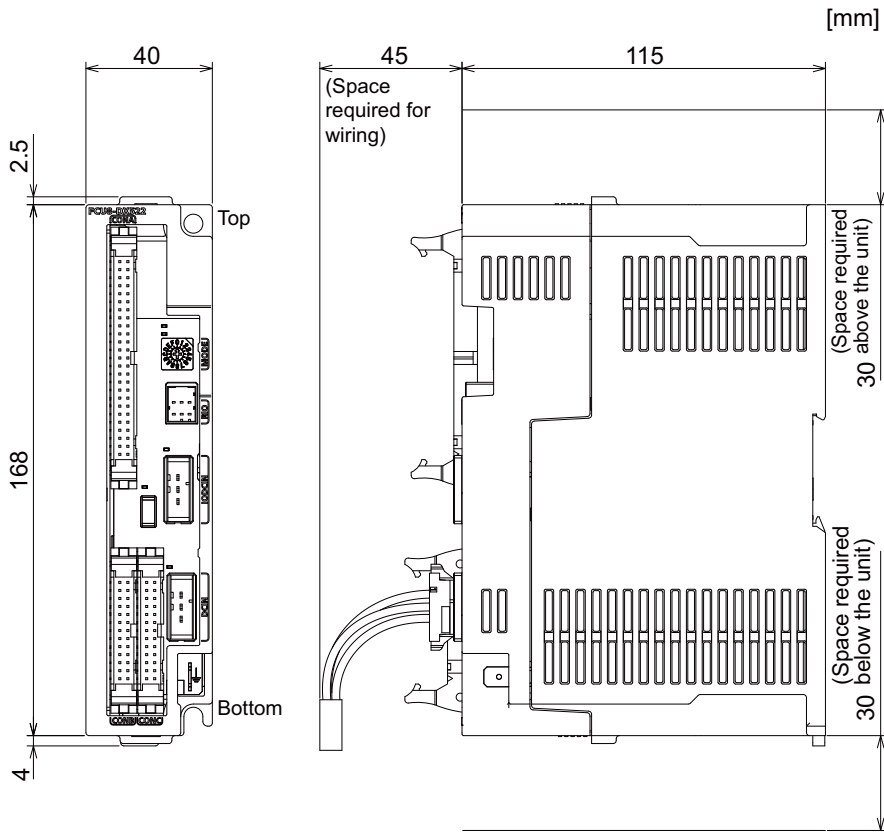

Installation dimensions

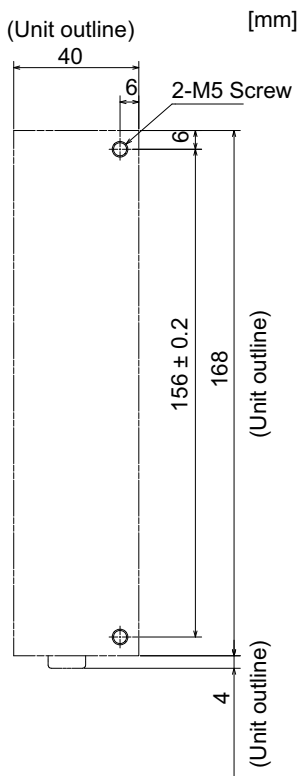

4.12 Function Expansion Unit

4.12.1 Encoder (Manual Pulse Generator) I/F Expansion (FCU8-EX544)

Outline dimensions

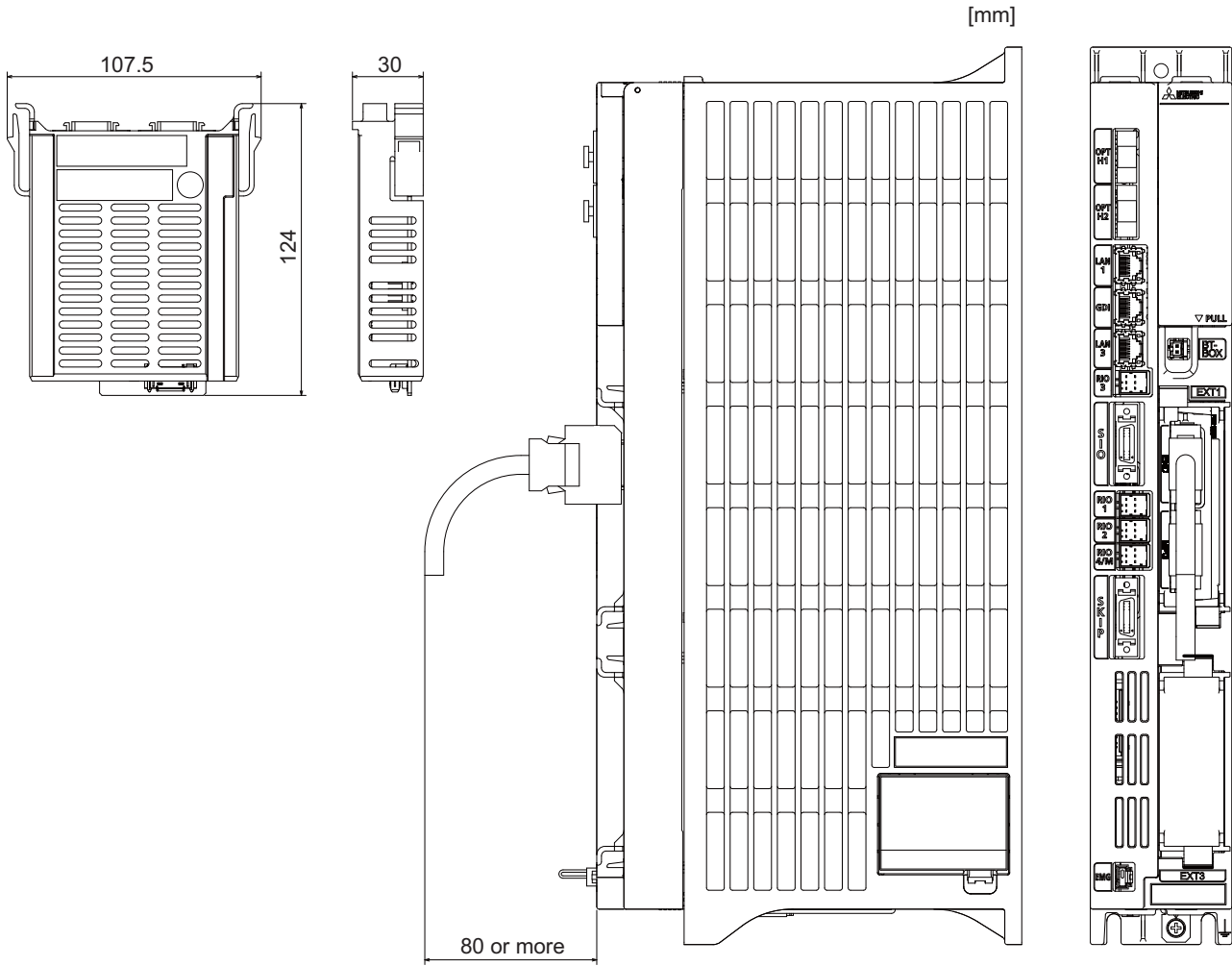

4.12.2 CC-Link (FCU8-EX561)

Outline dimensions

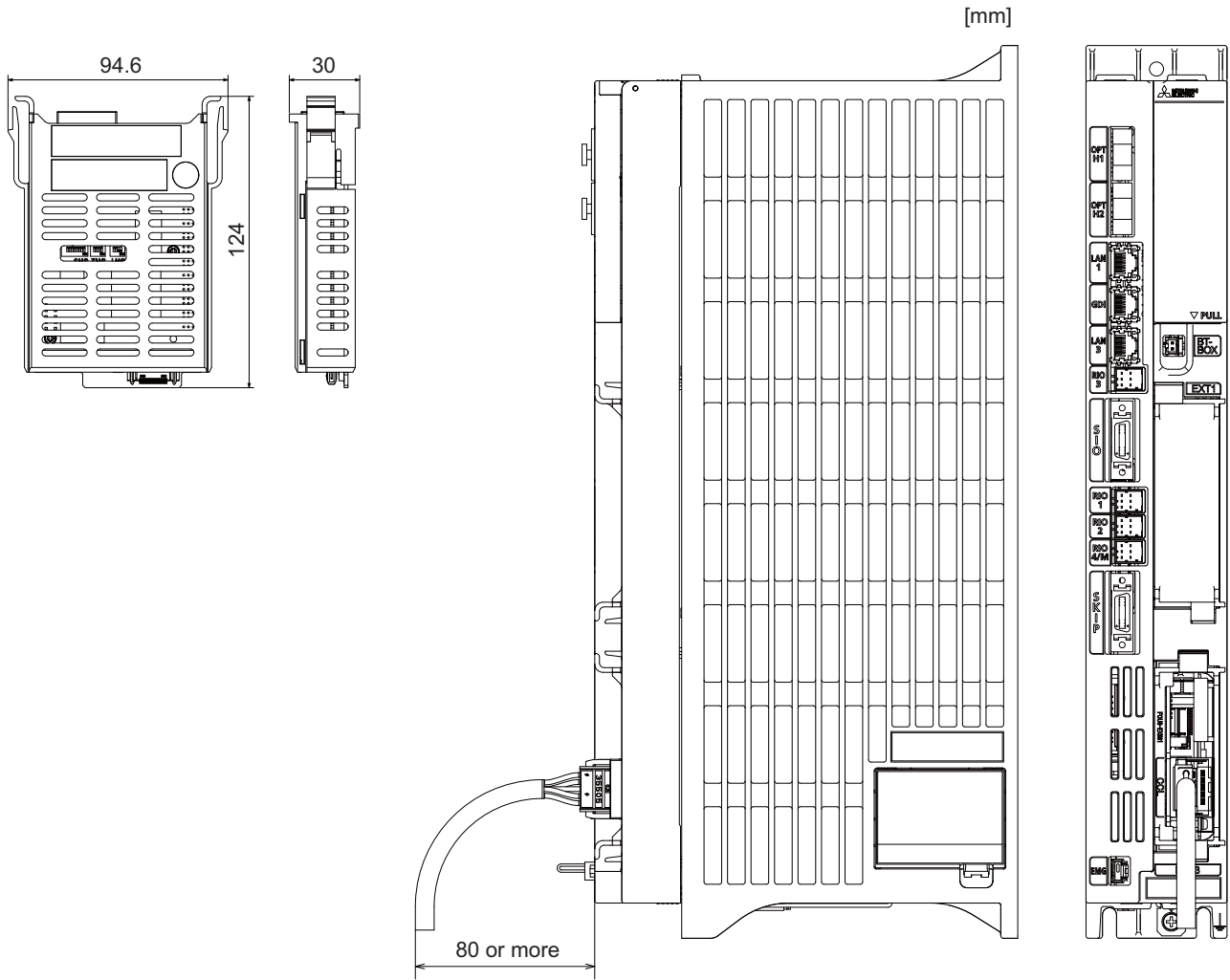

4.12.4 CC-Link IE Field (FCU8-EX564)

Outline dimensions

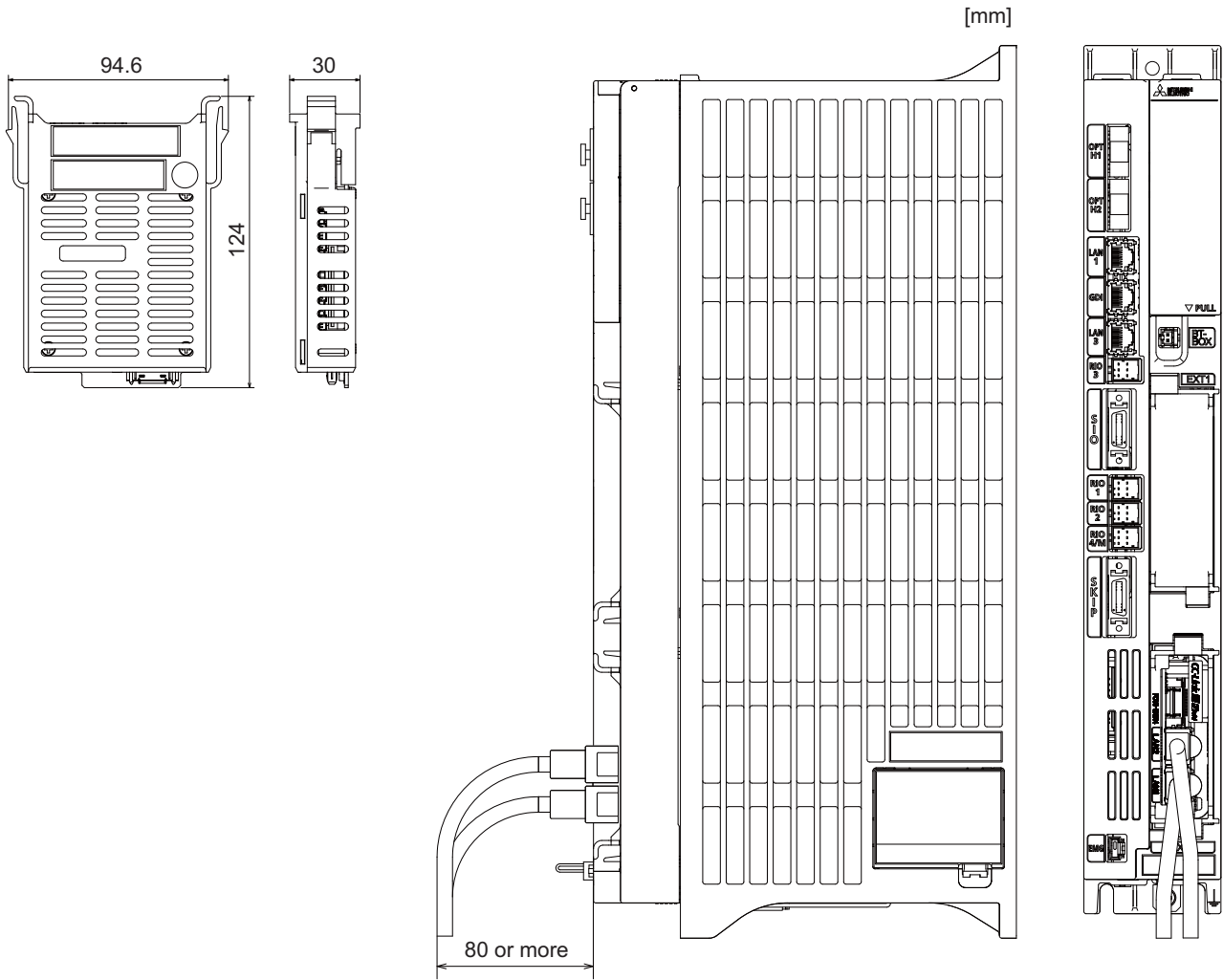

4.12.5 EtherNet/IP (FCU8-EX565)

Outline dimensions

[mm]

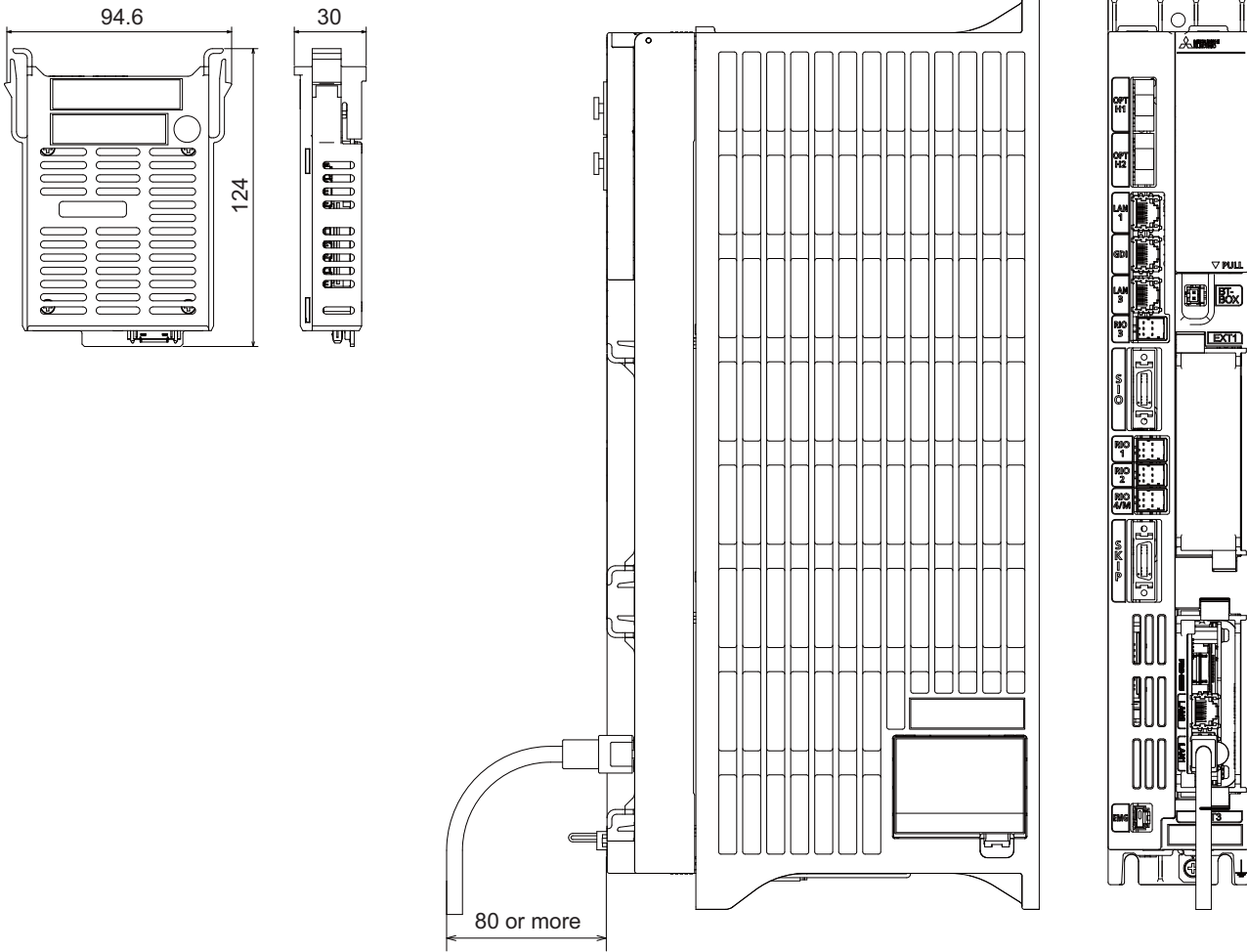

4.12.6 FL-net (FCU8-EX568)

Outline dimensions

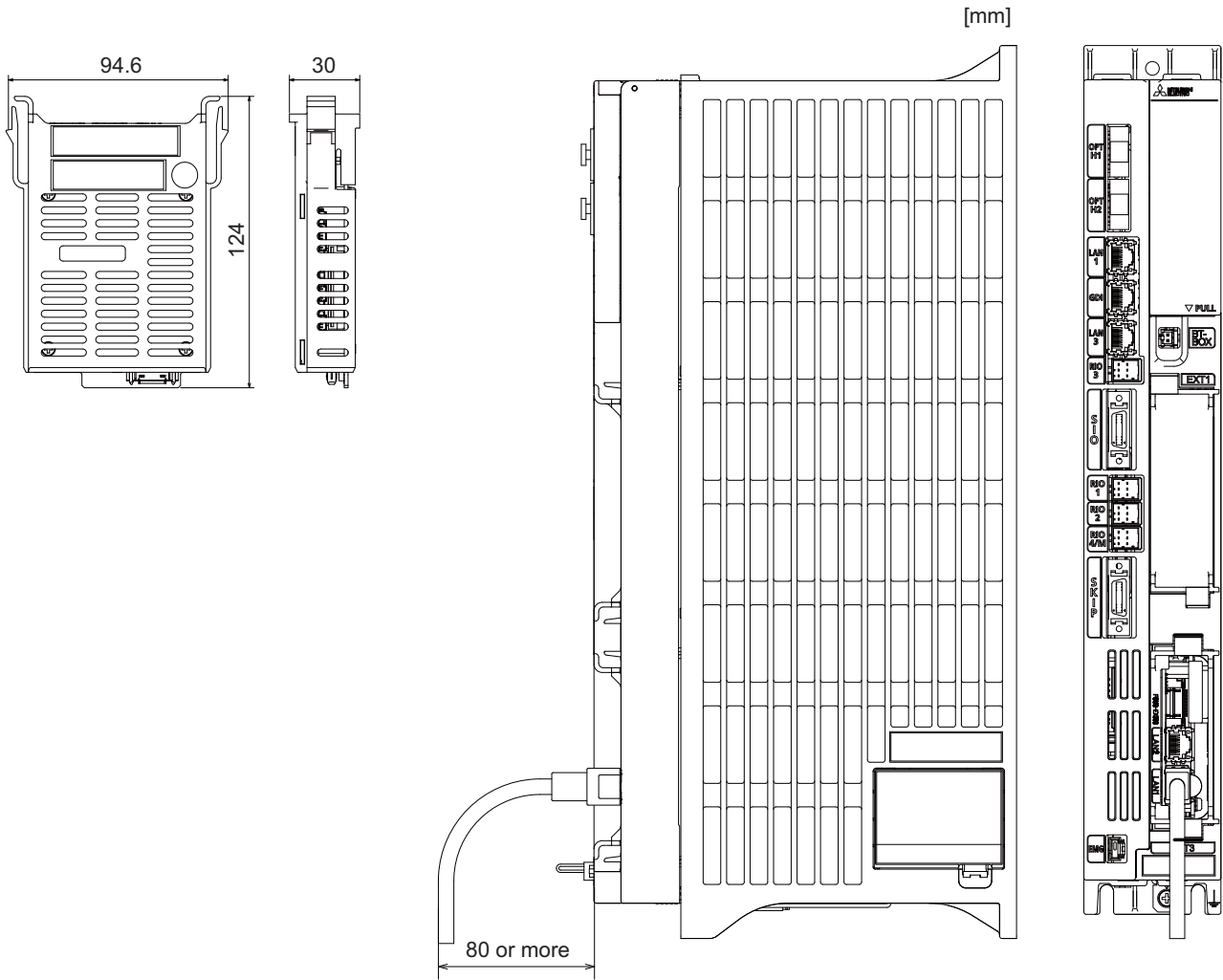

4.13 Side Memory I/F Unit

Note

(1) Side memory I/F unit is only for 19-type display unit.

4.13.1 FCU8-EP201-2

Outline dimensions

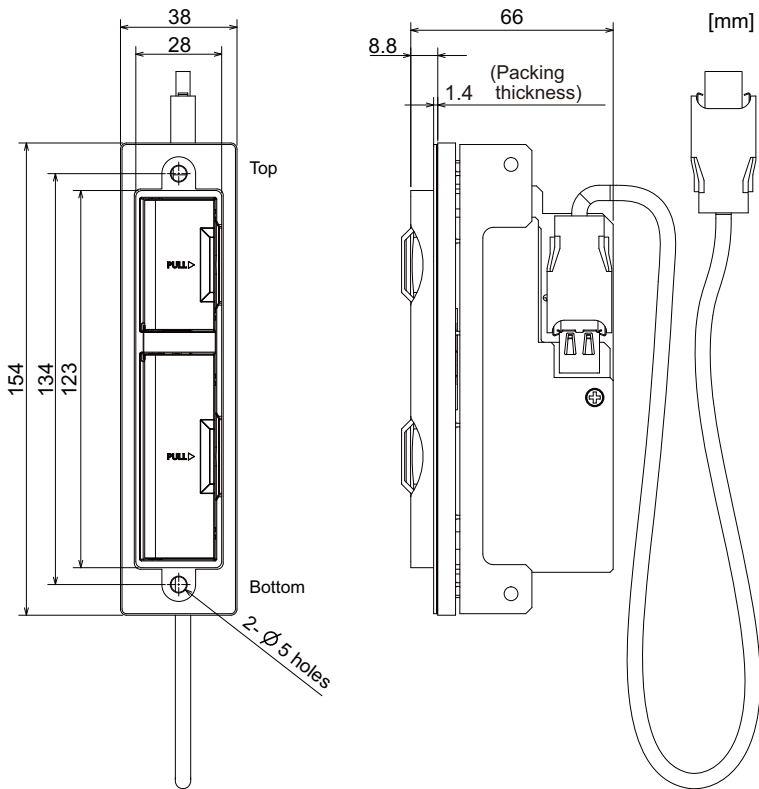

Installation dimensions

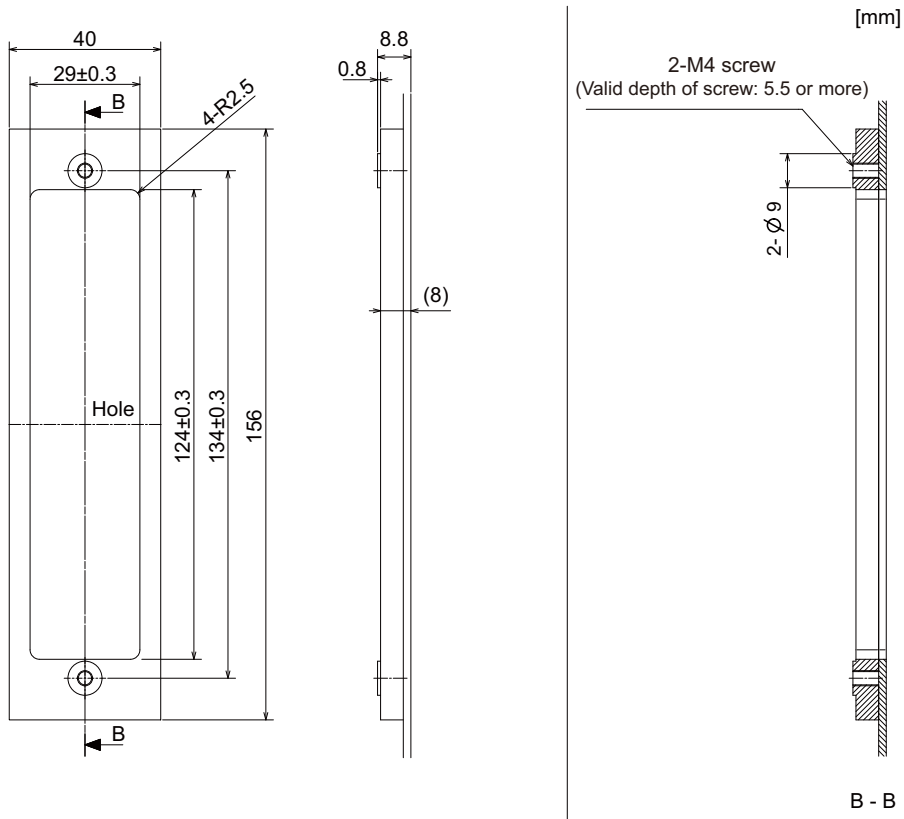

4.14 Manual Pulse Generator

4.14.1 5 V Manual Pulse Generator (UFO-01-2Z9)

■ 100 pulse/rev

Outline dimensions

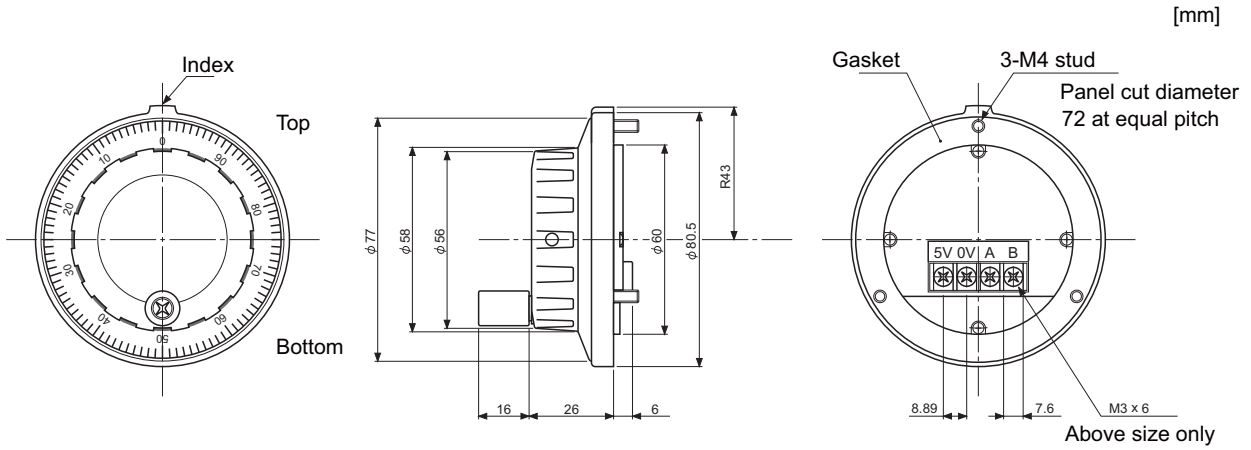

Panel cut dimensions

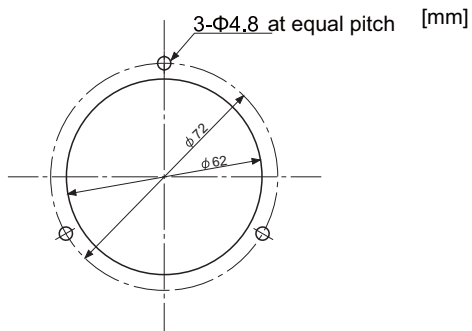

Produced by NIDEC NEMICON CORPORATION

4.14.2 12 V Manual Pulse Generator (HD60C)

■ 25 pulse/rev

Outline dimensions

[mm]

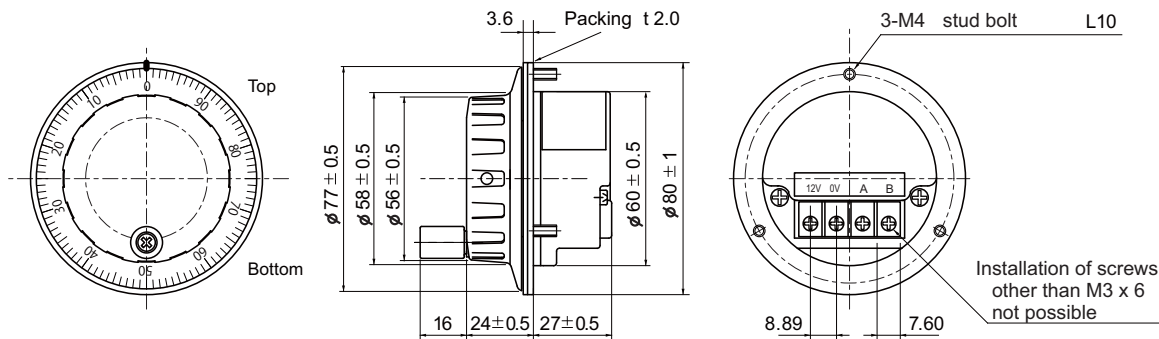

Panel cut dimensions

[mm]

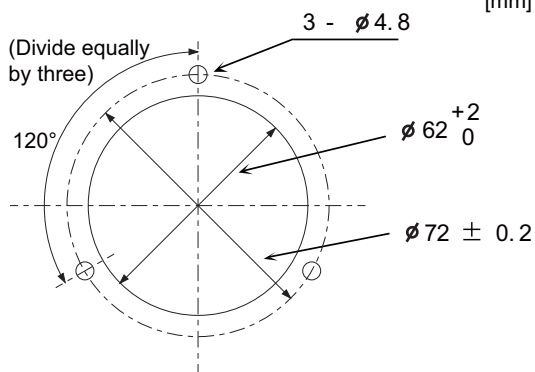

4.15 Synchronous Feed Encoder

4.15.1 Synchronous Feed Encoder (OSE-1024-3-15-68)

Outline dimensions

[mm]

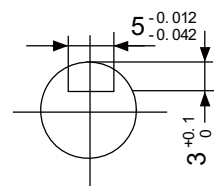
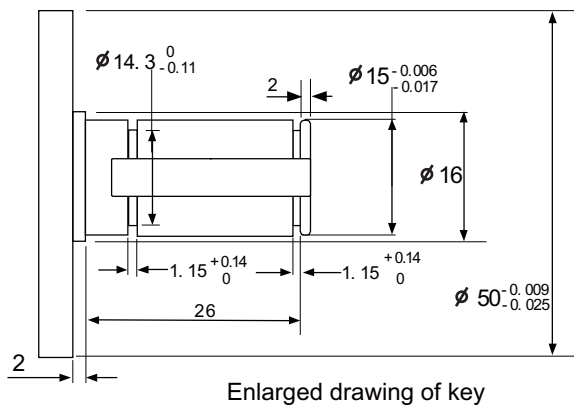
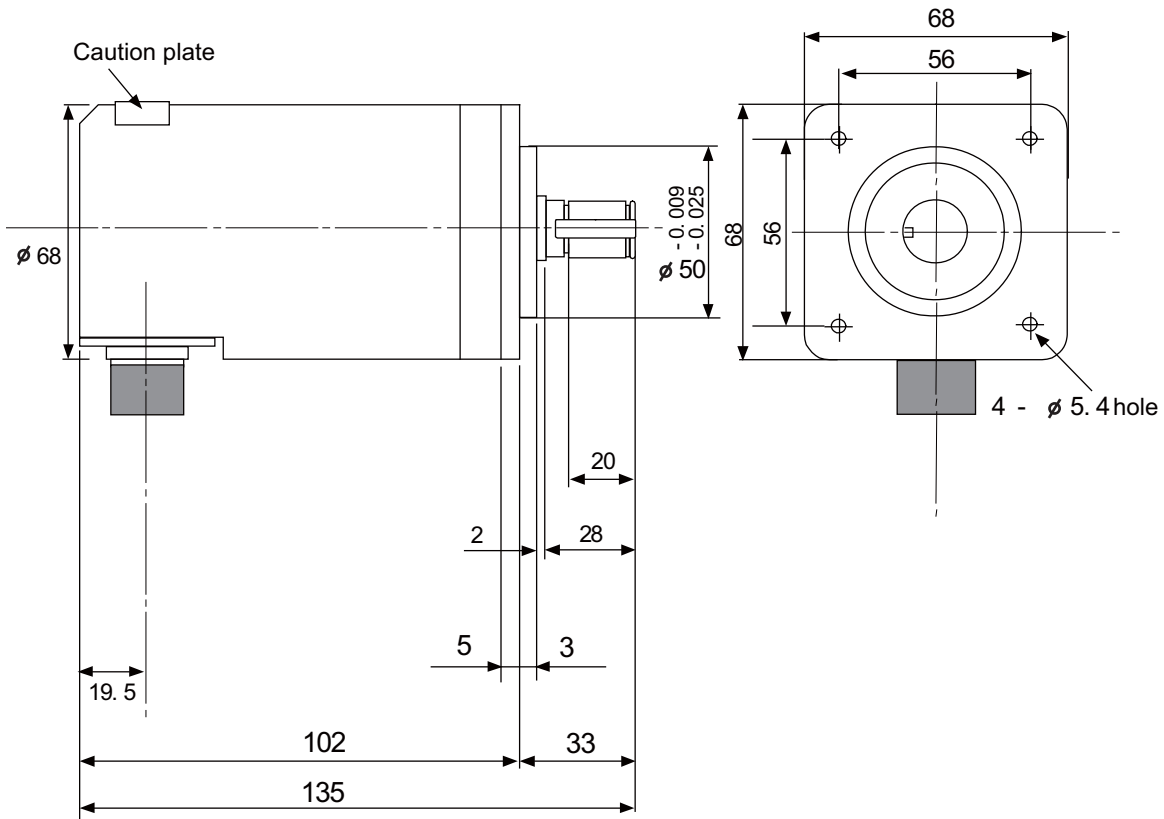

Cross section BB
Valid depth of key groove is 21mm

Connector

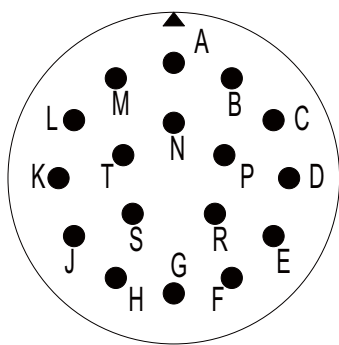

<Connector pin assignment>

Pin	Function	Pin	Function
A	A phase	K	0 V
B	Z phase	L	-
C	B phase	M	-
D	-	N	A phase reverse
E	Case grounding	P	Z phase reverse
F	-	R	B phase reverse
G	-	S	-
H	+5 V	T	-
J	-		

4.16 Machine Operation Panel

4.16.1 Main Panels A/B

(FCU8-KB921/FCU8-KB922/FCU8-KB925, FCU8-KB923/FCU8-KB924/FCU8-KB926)

Outline dimensions: FCU8-KB921

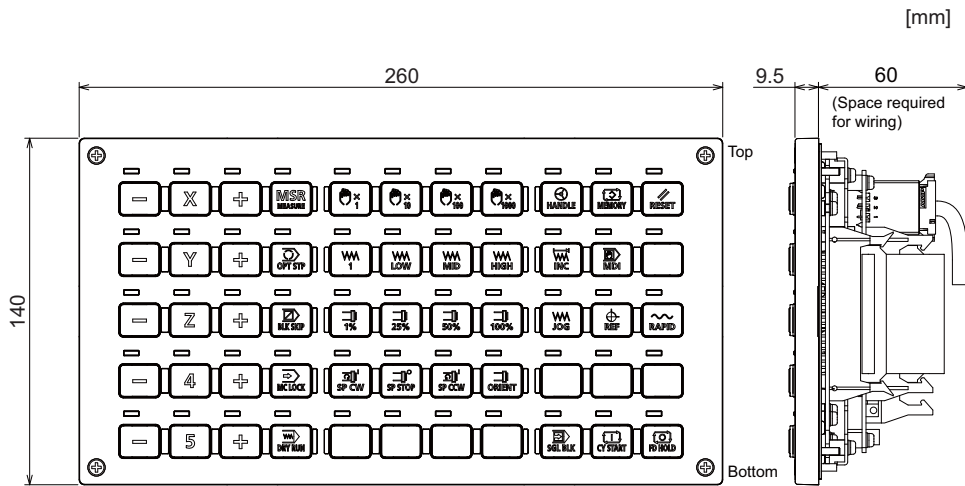

Outline dimensions: FCU8-KB922

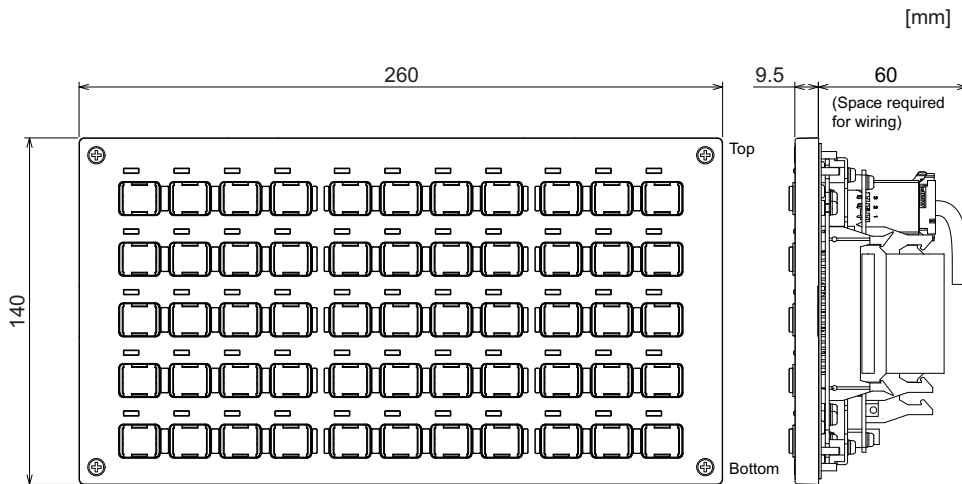

Outline dimensions: FCU8-KB925

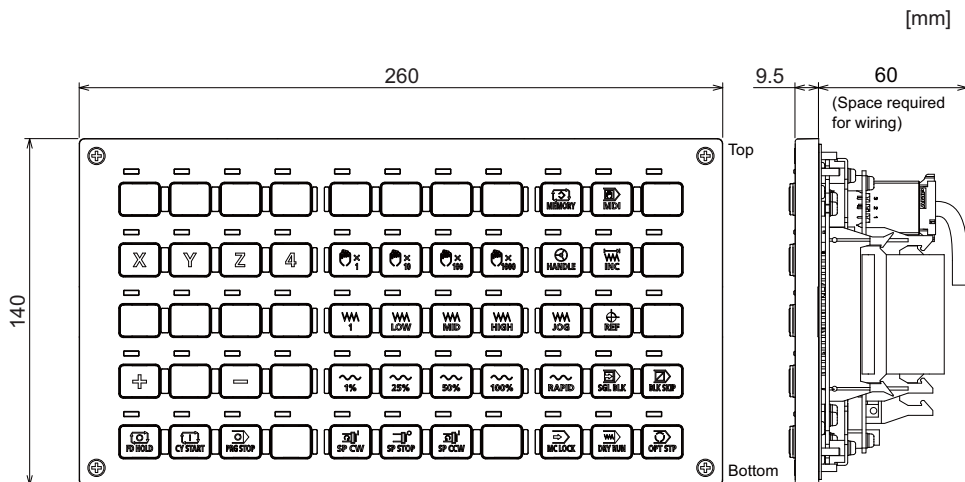

Outline dimensions: FCU8-KB923

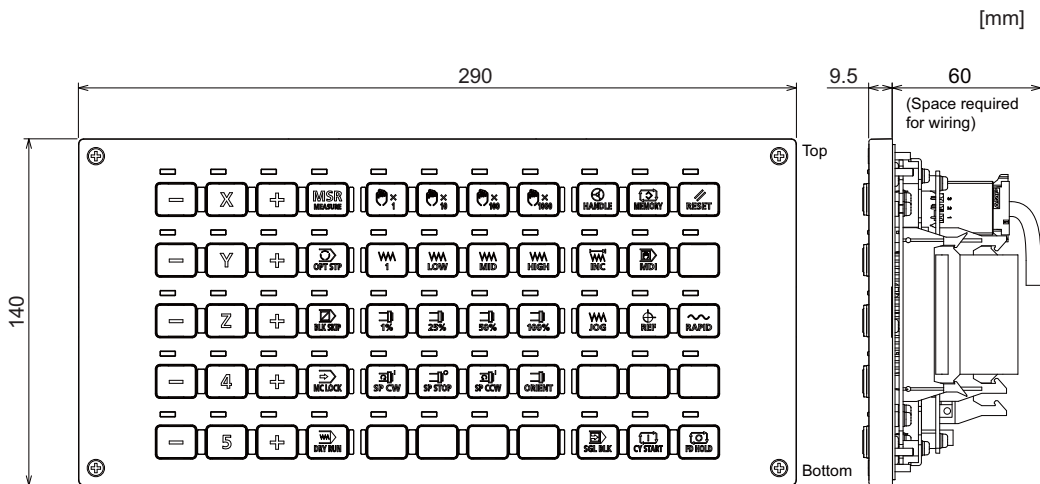

Outline dimensions: FCU8-KB924

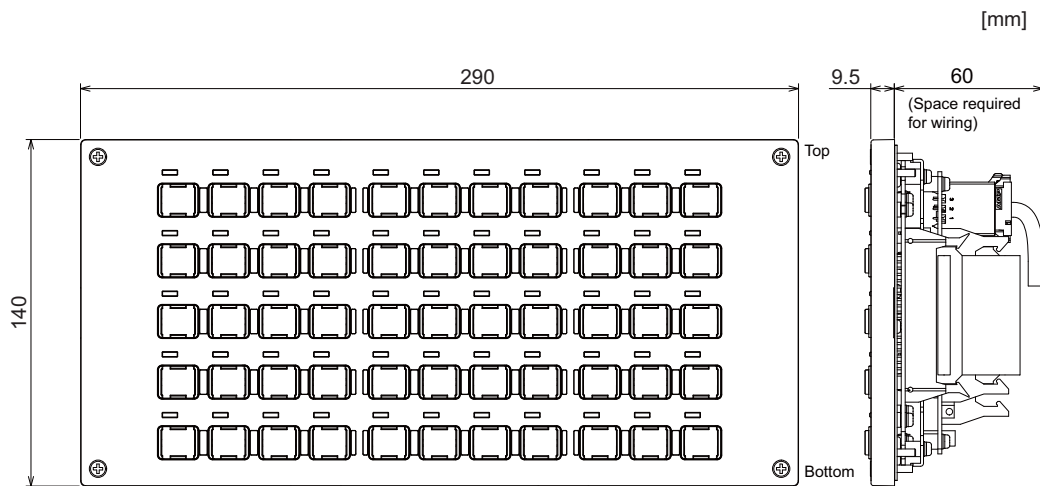

Outline dimensions: FCU8-KB926

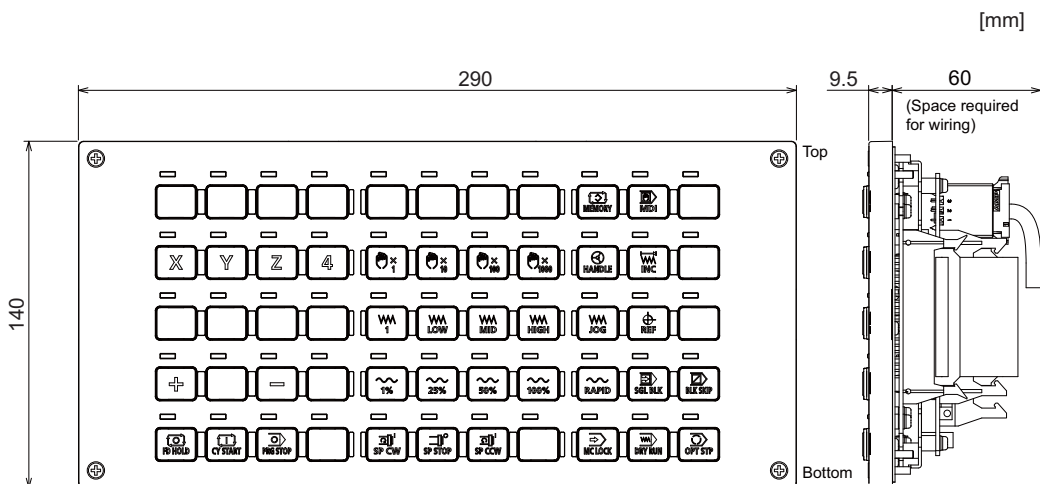

Letter label dimension: FCU8-KB922/FCU8-KB924

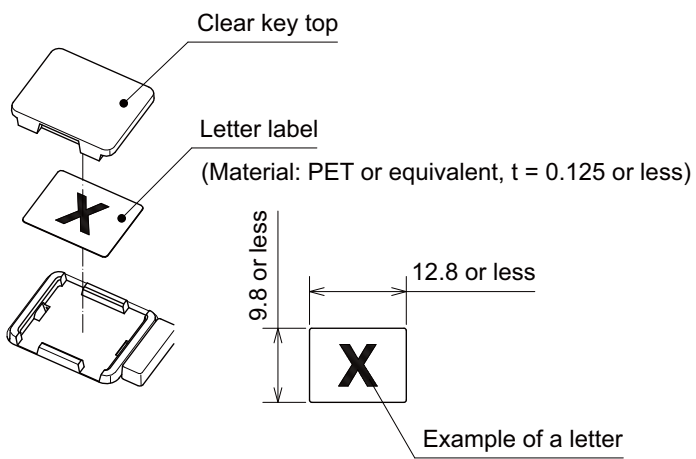

4.16.2 Sub Panel A (FCU8-KB931/FCU8-KB941)

Outline dimensions: FCU8-KB931

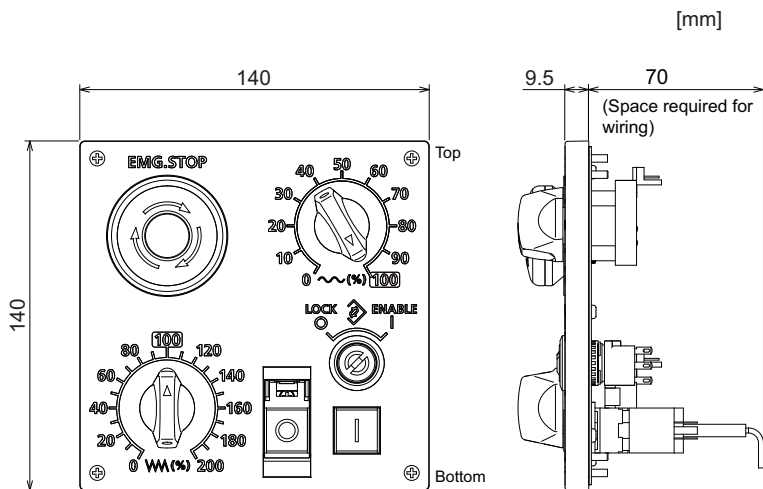

Outline dimensions: FCU8-KB941

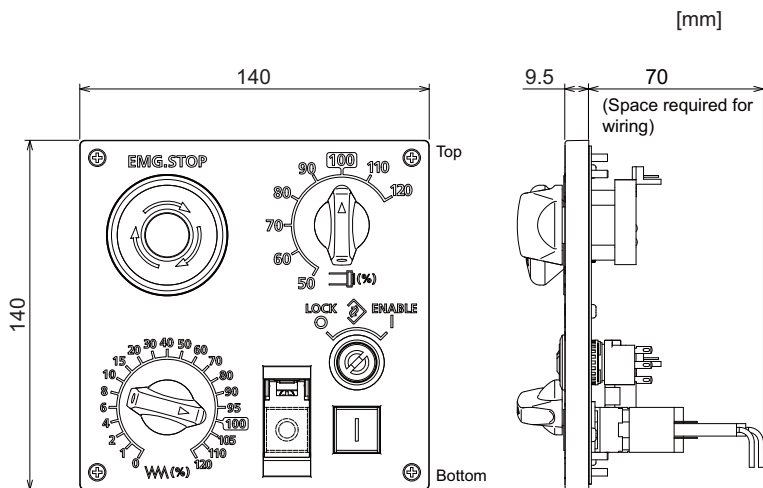

Panel cut dimensions: FCU8-KB931/FCU8-KB941

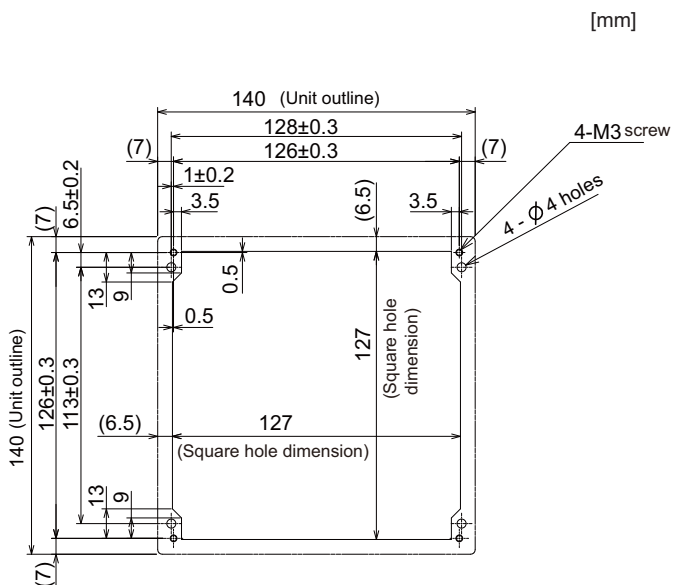

4.17 Handy Terminal

Item	Unit name		Handy terminal
	Type		HG1T-SB12UH-MK1346-L5
General specifications	Ambient temperature	During operation	0 to 40 °C
		During storage	-20 °C to 60 °C
	Ambient humidity		Long term: 10 to 75% RH (with no dew condensation)
			Short term: 10 to 95% RH (with no dew condensation) (*1)
	Vibration resistance	During operation	9.8 m/s ² [1.0 G] or less, 10 to 55 Hz
	Shock resistance	During storage	98 m/s ² [10.0 G] or less
Working atmosphere		No corrosive gases, dust or oil mist	
Power specifications	Power supply voltage		24 VDC ±5% Ripple noise 240 mV (P-P)
	Current consumption	(max.)	0.2A
	Instantaneous stop tolerance time		24 VDC : 4 ms or less
Others	Heating value		4 W (max.)
	Mass		0.6 kg

(*1) "Short term" means within one month.

Note

(1) The unit is an IP65F equivalent.

Dimension and names of parts

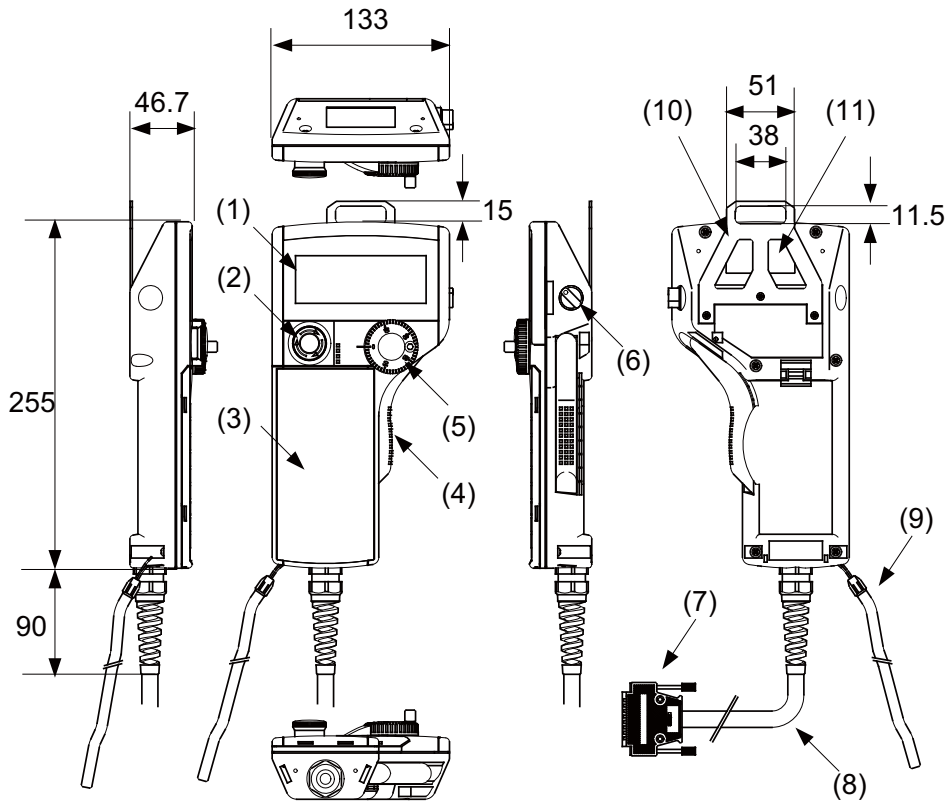

No.	Name	Function/Specification	No.	Name	Function/Specification
(1)	LCD	Monochrome display with backlight 192 (W) × 64 (H) dots	(7)	HOST	Host interface connector (DDK: 17JE-23250-02(D8A6))
(2)	SW1	Emergency stop switch Contact rating/Contact: 24 VDC, 1A Contact configuration: 2b contacts (IDEC Corporation: HA1E-V2S2VR)	(8)	-	Host interface cable (5 m)
(3)	-	Membrane switch (*1)	(9)	-	Simplified hand strap (IDEC Corporation: HG9Z-PS1)
(4)	SW2	Enable switch Contact rating/Contact: 24 VDC , 50 mA Contact configuration: 3-position contact × 2 (OFF-ON-OFF) (IDEC Corporation: HE3B-M2)	(10)	-	Panel mounting bracket (IDEC Corporation: HG9Z-TK1)
(5)	SW4	Manual Pulse Generator Output: Open collector 4.7 kΩ pull-up resistor is connected. (TOKYO SOKUTEIKIZAI CO., LTD: RE19PH50C16RR)	(11)	-	Serial number plate
(6)	SW6	Selector switch			

(*1) Do not press multiple switches simultaneously: When three or more switches are pressed simultaneously, unpressed switches are also detected as pressed ones.

4.18 Thermistor

4.18.1 Thermistor(PT3C-51F-M2)

Outline dimensions

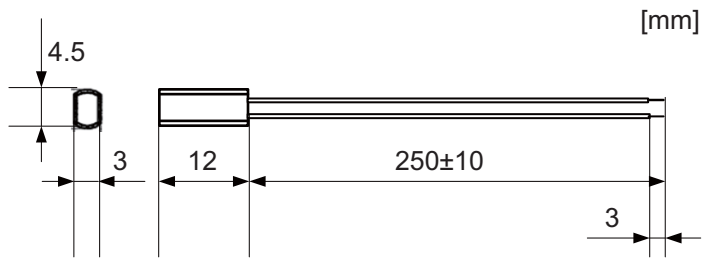

Made by SHIBAURA ELECTRONICS Co., Ltd.

Ambient temperature	-10 to + 190 °C
Insulation resistance	100 MΩ or more at 500 VDC [between case and lead wire]

4.19 Exclusive SD Cards

Item		FCU8-SD001G	FCU8-SD004G
Capacity		1 GB	4 GB
NAND Flash		SLC (*1)	
Ambient temperature	During operation	-25 °C to +85 °C	
	During storage	-40 °C to +85 °C	
Ambient humidity	During operation	5% to 95%RH (with no dew condensation)	
	During storage	5% to 95%RH (with no dew condensation)	

(*1) SLC stands for Single Level Cell, and it stores one bit data in each memory cell.

This provides longer life span and high product reliability in comparison with MLC (Multi Level Cell) and TLC (Triple Level Cell), which are commonly applied to SD cards.

Note

- (1) Do not touch the terminal part with fingers, etc. when handling the SD cards.
The contamination of the terminal part of SD card causes a contact failure or a trouble.

4.20 Specifications and Precautions of USB/SD/LAN Interface

4.20.1 USB Interface (Personal Computer Unit, Side Memory I/F Unit)

Standards	USB3.0	USB2.0
Data transfer speed(*1)	Super Speed (5 Gbps) High Speed (480 Mbps) Full Speed (12 Mbps) Low Speed (1.5 Mbps)	High Speed (480 Mbps) Full Speed (12 Mbps) Low Speed (1.5 Mbps)
Power supply to USB device	Supply voltage: 5 V \pm 5% Supply current: Max. 900 mA/port	Supply voltage: 5 V \pm 5% Supply current: Max. 500 mA/port (However, max. 200 mA/port for side memory I/F unit)
Number of free ports	Personal computer unit \times 2	Personal computer unit \times 4, Side memory interface unit \times 1
Max. cable length	3 m (For Super Speed. 5 m for up to High Speed)	5 m

(*1) Data transfer speed is the theoretical value on the standard, and the actual speed will be inferior to the value listed above. The transfer speed may be restrained depending on the specification of the connected device.

Note

(1) Side memory I/F unit is only for 19-type display unit.

■ Precautions for use of commercially available USB keyboards and mice (Only for the display unit with the computer.)

Mitsubishi Electric will not provide performance guarantee and maintenance for commercially available USB keyboards and mice. When any of them is to be used, careful performance check must be required by the machine tool builder.

Commercially available devices may not be compatible with Mitsubishi Electric units or appropriate temperature- or noise-wise for the factory automation environment.

Commercially available USB keyboards/mice are susceptible to noise, etc., and may cause a malfunction in the unit that may lead to an accident. Do not use them while the machine is operated.

■ Precautions for use of other commercially available USB devices (Only for the display unit with the computer.)

When connecting a commercially available USB device that requires power exceeding the maximum current, select the one of which power can be supplied from an outside source.

Mitsubishi Electric will not provide performance guarantee and maintenance for commercially available USB printer, USB floppy disk, USB memory, USB hub, USB-CD drive, USB-DVD drive, and other USB devices. Commercially available devices may not be compatible with Mitsubishi Electric units or appropriate temperature- or noise-wise for the factory automation environment.

In the case of using one of them, careful performance check must be required by the machine tool builder, and necessary noise countermeasures, such as executing EMI countermeasures or adding the ferrite cores, must be taken.

■ Precautions for insertion/removal of USB memory

When inserting/removing a USB memory, turn the Mitsubishi Electric device's power OFF. Do not pull out the USB memory or turn OFF the power during access to the USB memory. Failure to observe this could cause the memory contents to be erased.

When inserting/removing a USB memory, be sure to have enough interval to perform that (about 10 seconds or more).

In case of emergency, always perform backups by having your important data duplicate, etc. as Mitsubishi Electric will not guarantee the broken or lost data.

■ Precaution for operation with front-side USB memory

A USB memory to be used has to be supported USB2.0 Hi-Speed (480 Mbps).

When connecting the USB memory, connect it directly without using the extension cable or USB hub.

Machine vibration may cause the USB memory to fall out depending on environment. Therefore, the operation with the front-side USB memory is required to be performed on your own responsibility.

■ Static electricity

Static electricity may cause malfunction of USB memory. Before using the USB memory, make sure to touch a conductive material such as a grounded metal object to discharge static electricity accumulated in human body, etc.

4.20.2 SD Interface (Control Unit, Side Memory I/F Unit)

Standards	SD/SDHC (*1)
Transfer speed	According to the connecting SD card
Maximum capacity	32 GB
Number of free ports	Control unit × 1, Side memory I/F unit × 1

(*1) SDXC is not supported.

Note

(1) Side memory I/F unit is only for 19-type display unit.

■ Precautions for use of commercially available SD card

Mitsubishi Electric will not provide performance guarantee and maintenance for commercially available SD card, mini SD card or micro SD card (requires converting adapter). When any of them is to be used, careful performance check must be required by the machine tool builder.

Commercially available devices may not be compatible with Mitsubishi Electric units or suitable FA environment for temperature- or noise-wise.

■ Precautions for insertion/removal of SD card

When inserting/removing an SD card, turn the Mitsubishi Electric device's power OFF. Do not pull out the card or turn OFF the power during access to the SD card. Failure to observe this could cause the memory contents to be erased.

In case of emergency, always perform backups by having your important data duplicate, etc. as Mitsubishi Electric will not guarantee the broken or lost data.

■ Static electricity

Static electricity may cause malfunction of SD card. Before using the SD card, make sure to touch a conductive material such as a grounded metal object to discharge static electricity accumulated in human body, etc.

4.20.3 LAN Interface (Control Unit, Personal Computer Unit)

Standards	1000BASE-T/100BASE-TX/10BASE-T	100BASE-TX/10BASE-T
Data transfer speed (*1)	1000 Mbps/100 Mbps/10 Mbps	100 Mbps/10 Mbps
Number of free ports	Control unit (LAN1) × 1, Personal computer unit × 1	Control unit (LAN3) × 1
Max. cable length	100 m	100 m

(*1) Data transfer speed is the theoretical value on the standard, and the actual speed will be inferior to the value listed above. The transfer speed may be restrained depending on the specification of the connected device.

Note

(1) When half-duplex communication is made, the response time may become long depending on the connected device. Use full-duplex communication to connect with the opposite device via a switching HUB.

■ Precautions for selection of LAN cable

Make sure to select the LAN cables which are "category 5e or above" and "shielded". Cable wire material with double shielded, which is appropriate for FA environment, is recommended.

M800VS/M80V Series Hardware



System Basic Configuration (M800VS/M80V Series)

1.1 System Basic Configuration Drawing

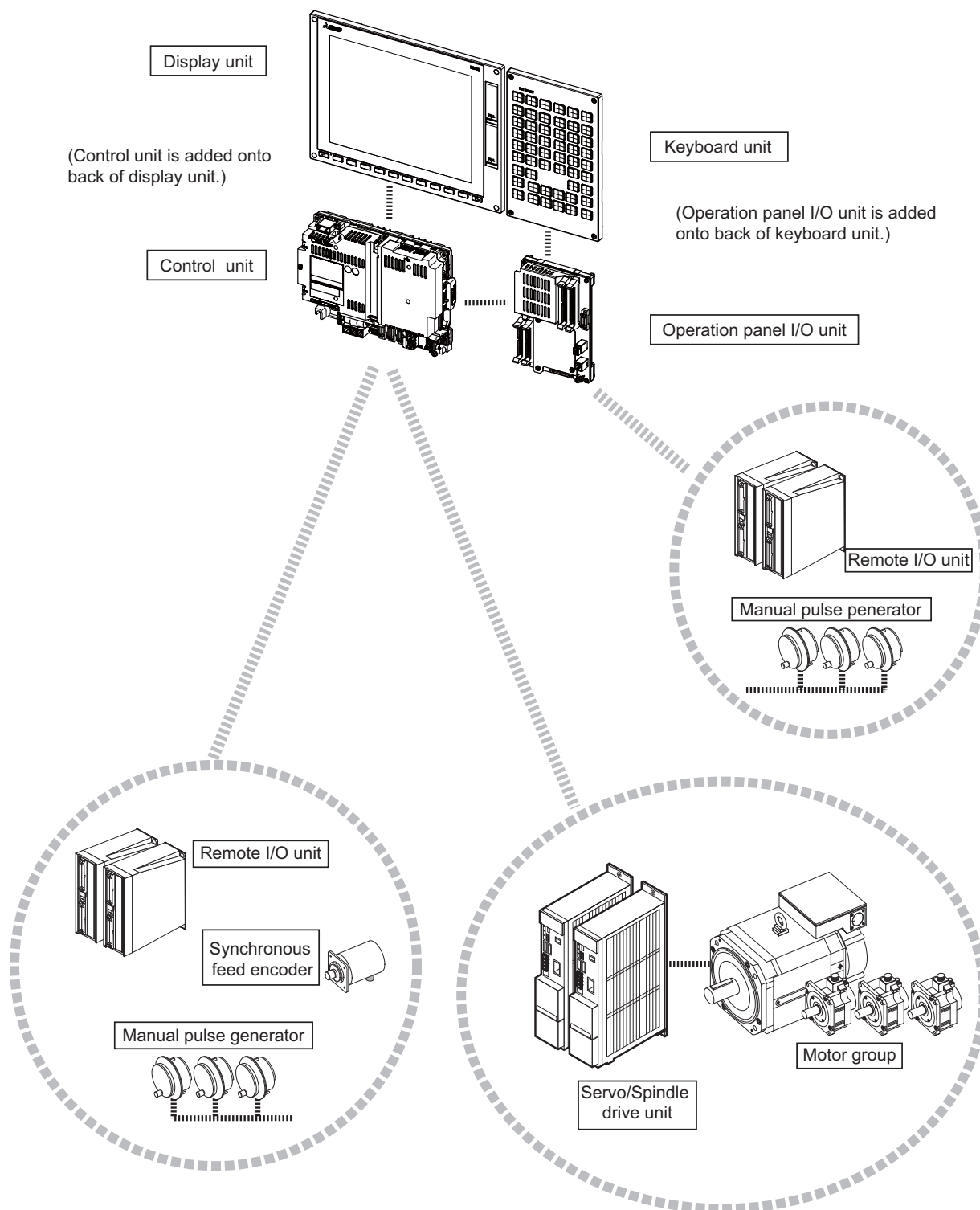

Note

(1) For the drive unit configuration, refer to the instruction manual of the drive unit you use.

General Connection Diagram (M800VS/M80V Series)

Typical general connection diagrams for respective models are described.

Refer to the following chapters for parts where the connection differs depending on the unit configuration.

2.3 19-type Display Unit

2.4 Connecting an Operation Panel I/O Unit (FCU8-DX834)

2.5 Connecting a Pulse-controlled Inverter (M80V Series)

2.6 Connecting a BiSS Encoder

2.7 Connecting an Image Input Expansion Unit

2.8 Connecting a Laser I/F Unit

2.9 Connecting an EcoMonitorLight

2.1 M800VS Series

⋯ Dotted lines indicate the sections prepared by the machine tool builder.
 <> Angle brackets indicates attached cable of unit.

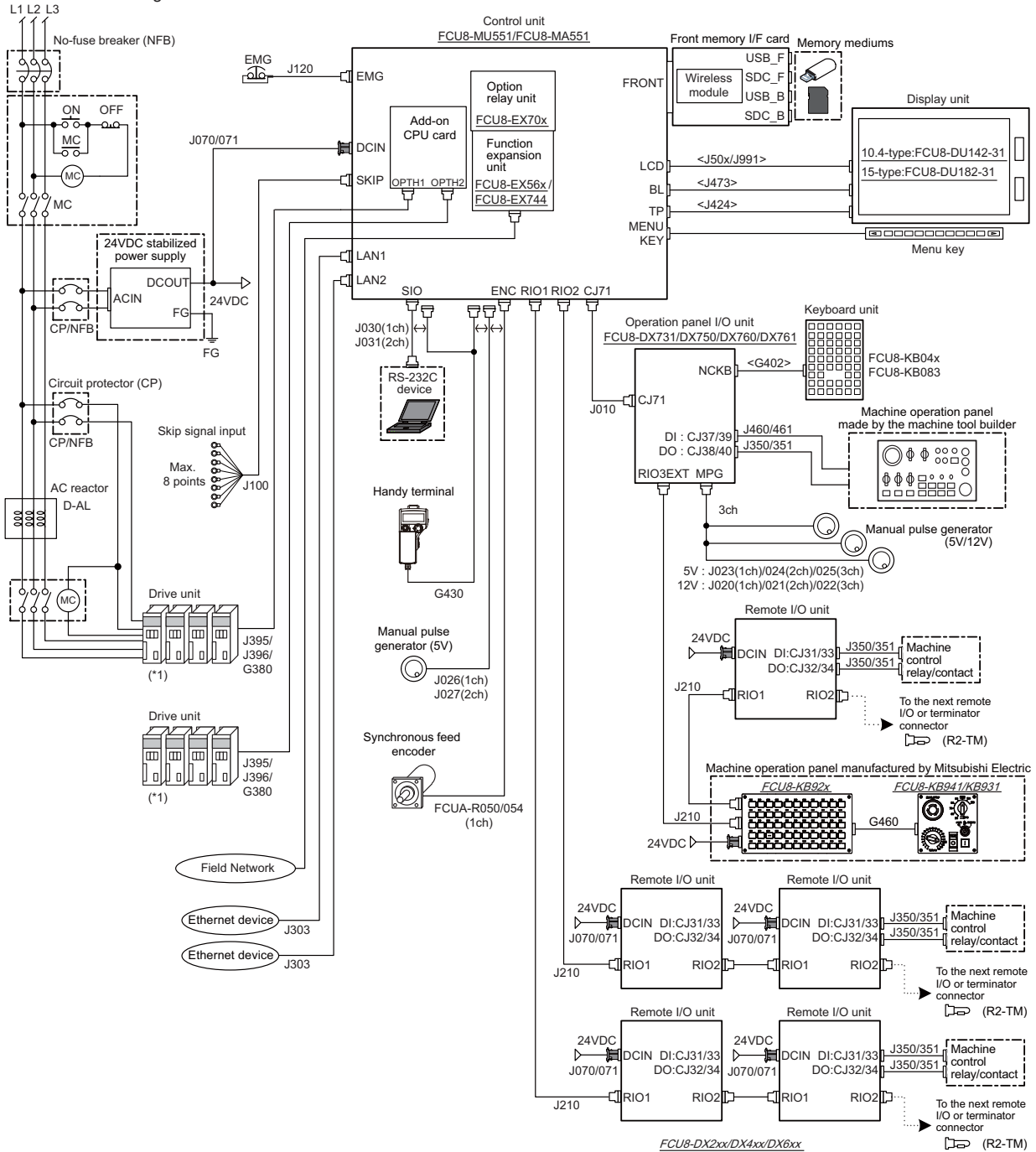

(*1) For information on how to connect the drive unit, refer to the drive unit's manual.

2.2 M80V Series

The general connection diagram with smart safety observation function is as below.

Without smart safety observation function, functional safety expansion unit is not installed in the control unit.

⋯ Dotted lines indicate the sections prepared by the machine tool builder.

<> Angle brackets indicates attached cable of unit.

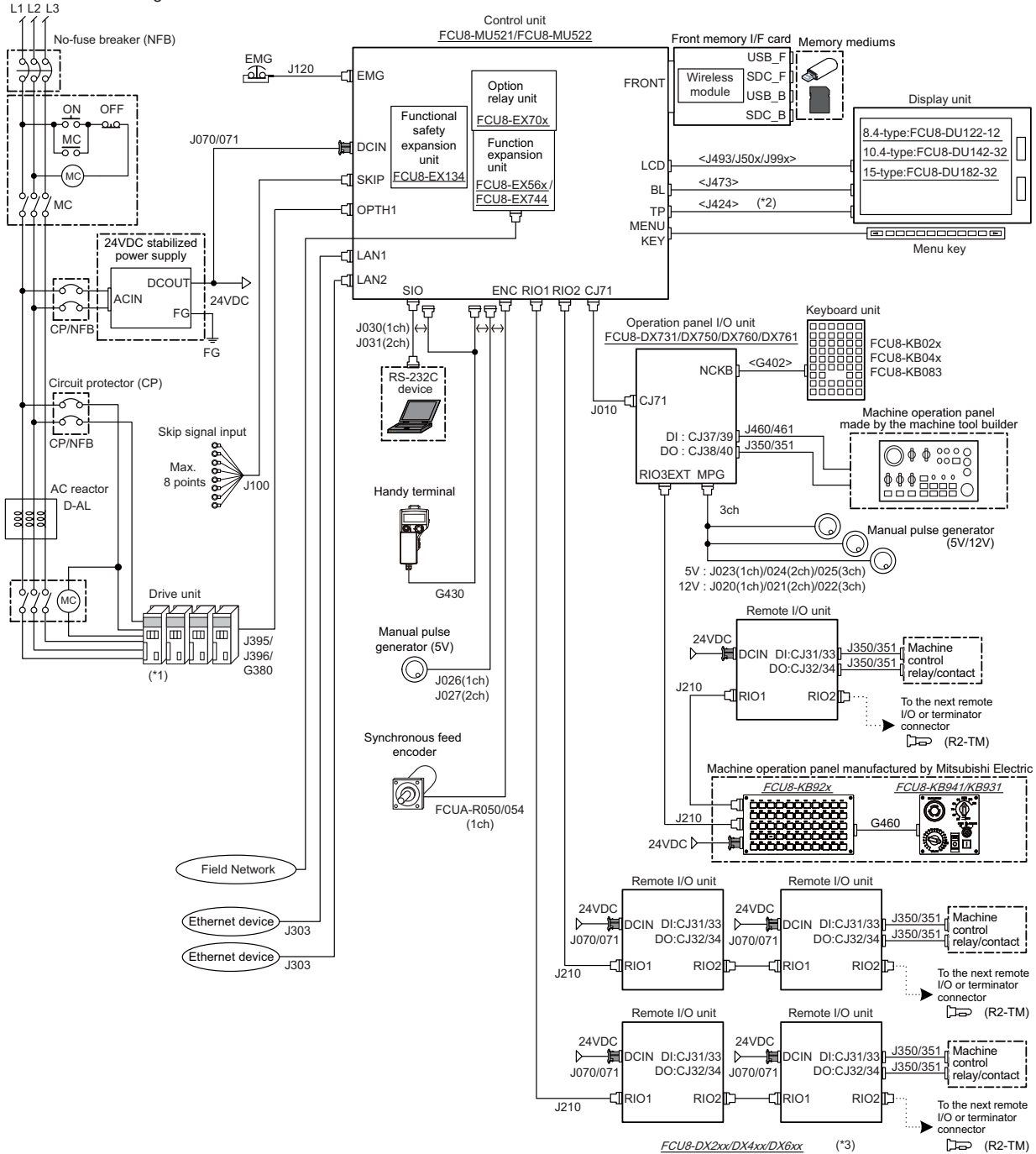

(*1) For information on how to connect the drive unit, refer to the drive unit's manual.

(*2) For the 8.4-type display unit, TP connector is not used.

(*3) The safety remote I/O unit is available only when the functional safety expansion unit is mounted.

2.3 19-type Display Unit

Dotted lines indicate the sections which is different from the other display units (8.4-type, 10.4-type, and 15-type) in the display unit (19-type).

To connect the 19-type display unit to the CNC, an image input expansion unit is required.

19-type display unit

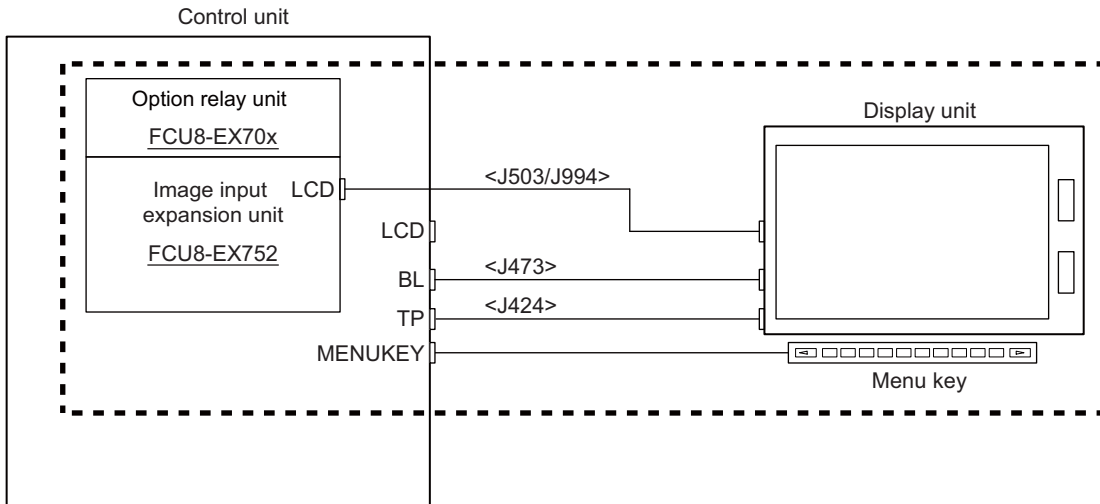

Other display units (8.4-type, 10.4-type, and 15-type)

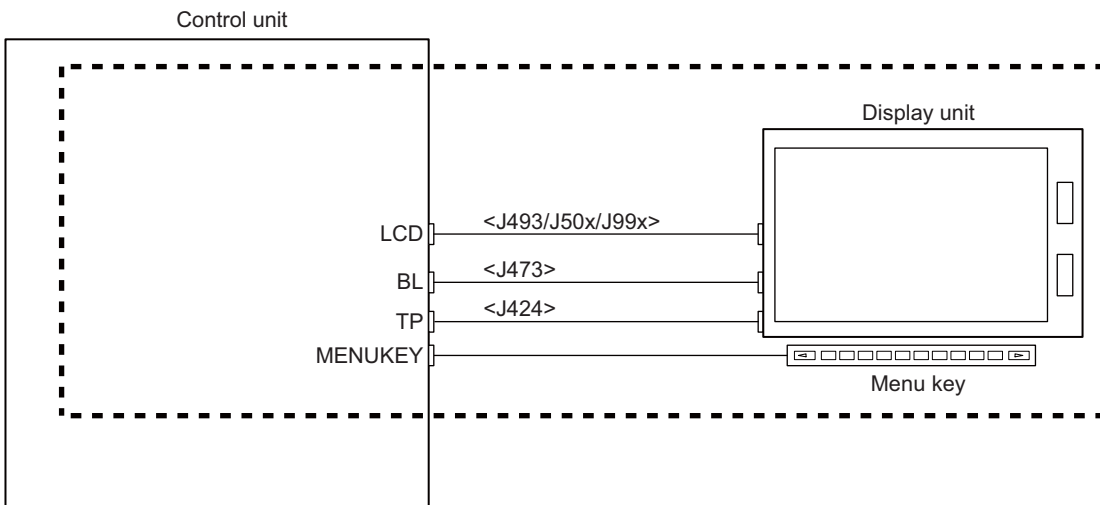

2.4 Connecting an Operation Panel I/O Unit (FCU8-DX834)

Dotted lines indicate the sections which is different from the FCU8-DX731/DX750/DX760/DX761 in FCU8-DX834.

FCU8-DX834

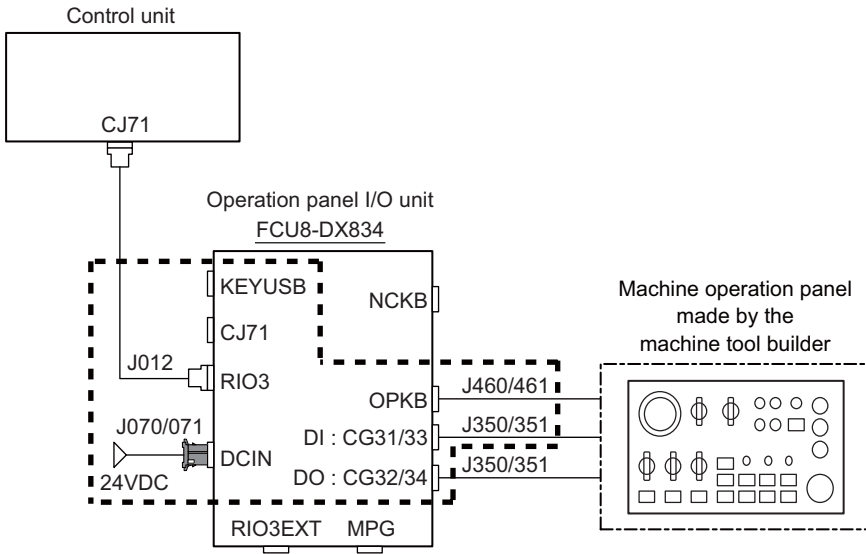

FCU8-DX731/DX750/DX760/DX761

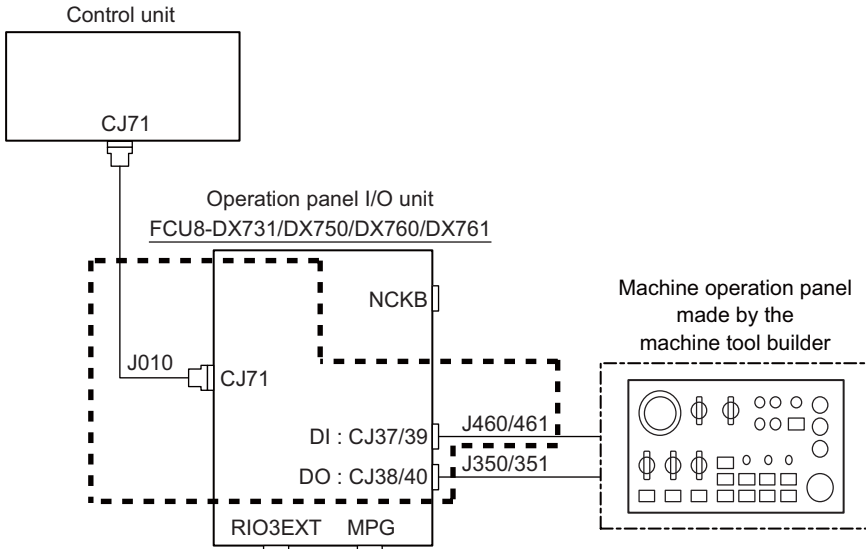

2.5 Connecting a Pulse-controlled Inverter (M80V Series)

Pulse-controlled inverter refers to an inverter capable of controlling spindle operation through pulse train input.

Connect a pulse-controlled inverter to RIO1 and RIO2 of the control unit.

The parts surrounded by the dotted lines in the figures below are different.

Connecting a pulse-controlled inverter

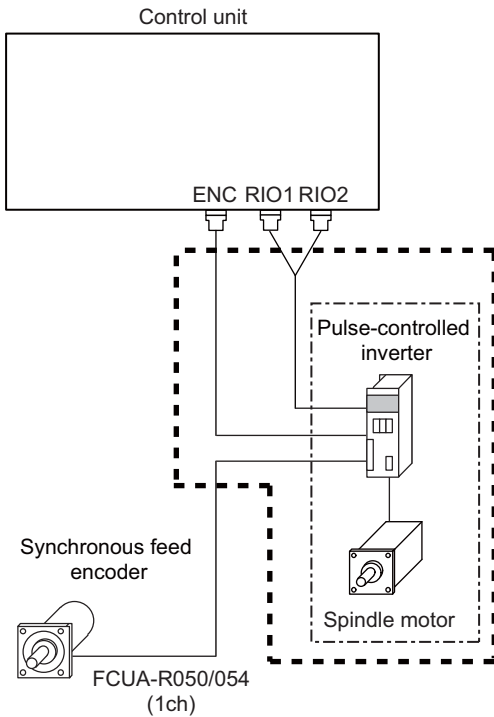

ENC/RIO1/RIO2 when the spindle drive unit is connected

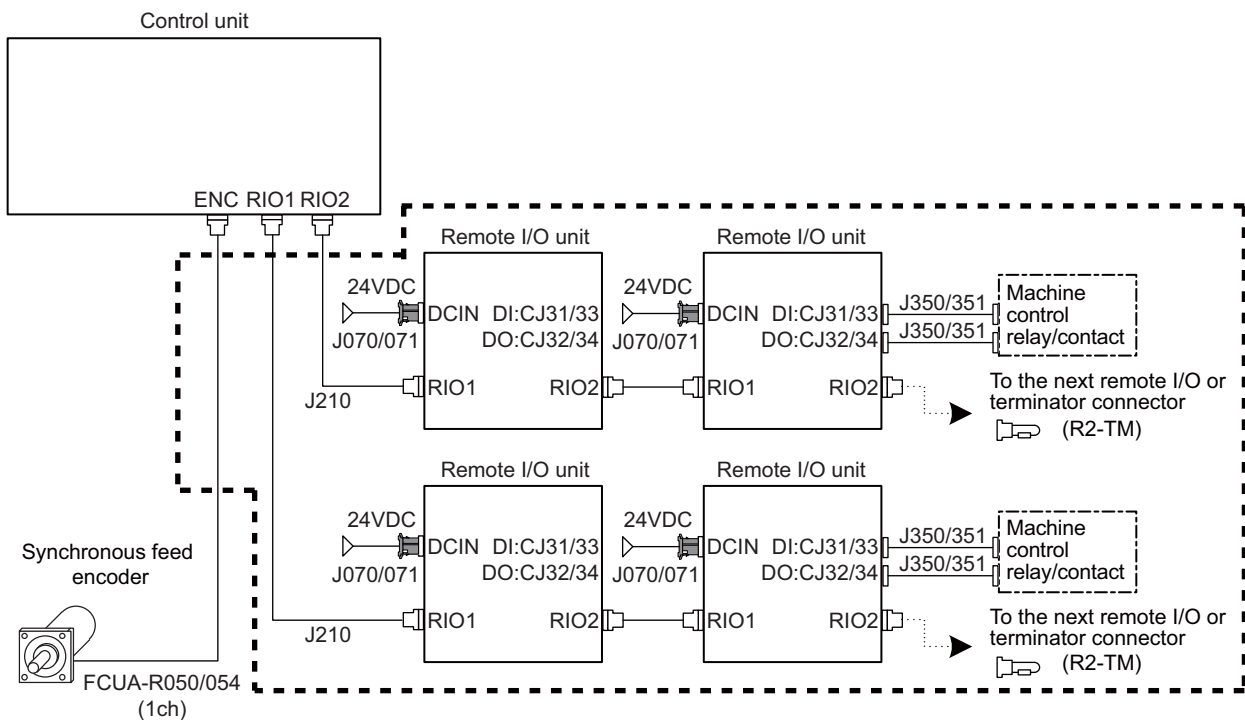

注意

- (1) When the pulse-controlled inverter is connected, the remote I/O unit cannot be connected to the either of the RIO1 connector or the RIO2 connector.

2.6 Connecting a BiSS Encoder

BiSS encoder refers to an encoder compatible with BiSS-C.

Connect the BiSS encoder to the ENC connector and the RIO2 connector of the control unit.

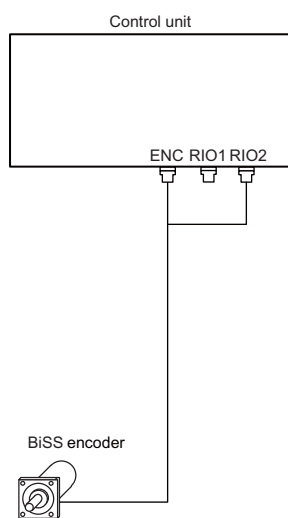

2.7 Connecting an Image Input Expansion Unit

Some connections differ depending on the display unit type.

10.4-type display unit and 15-type display unit

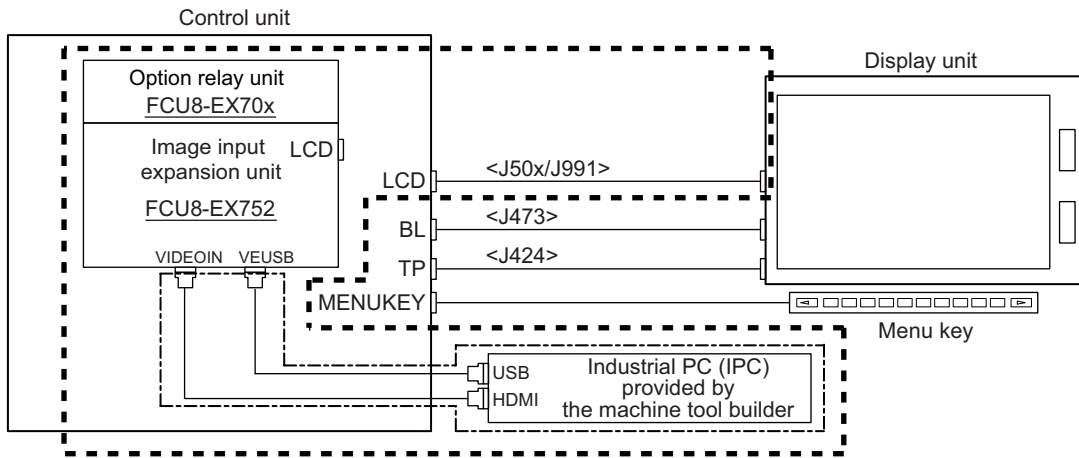

19-type display unit

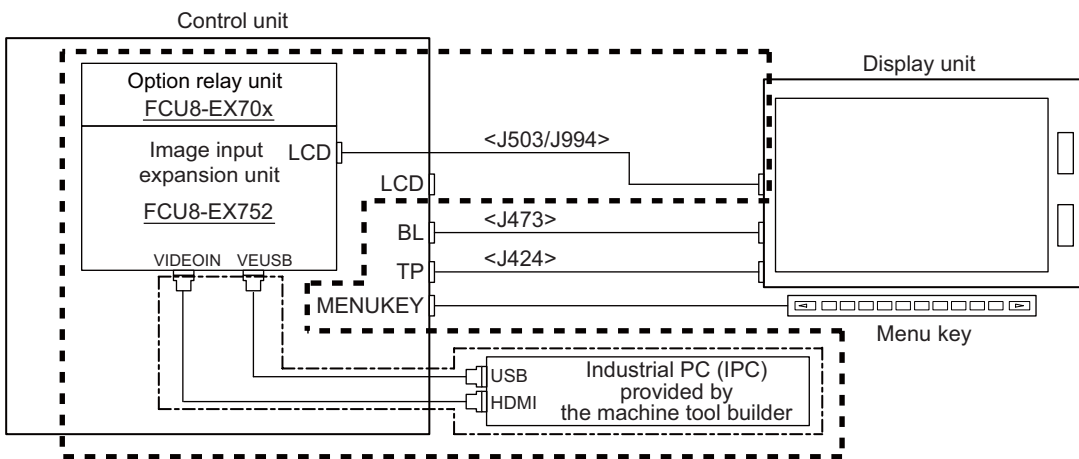

Connection without the image input expansion unit

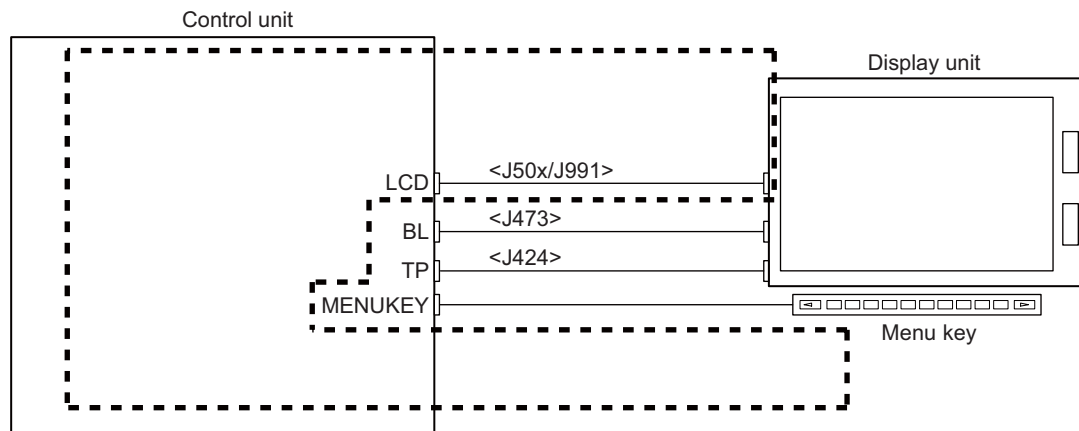

注意

(1) 8.4-type display unit does not support the image input expansion unit.

2.8 Connecting a Laser I/F Unit

Connect the laser I/F unit to RIO1 or RIO2 of the control unit.

The following figure shows an example of connecting the laser I/F unit to RIO2.

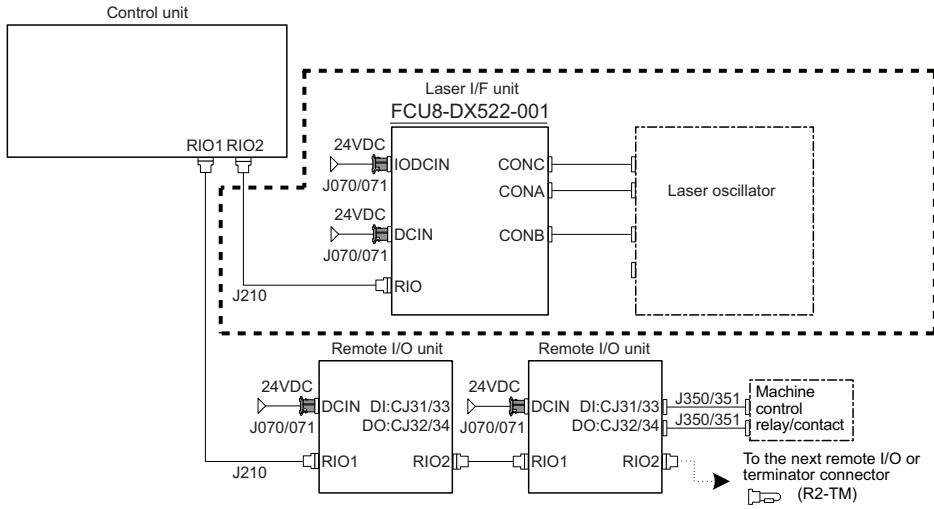

注意

- (1) The laser I/F unit occupies all one channel; therefore, a remote I/O unit cannot be connected before or after the laser I/F unit.

2.9 Connecting an EcoMonitorLight

Connect the EcoMonitorLight to RIO2 of the control unit.

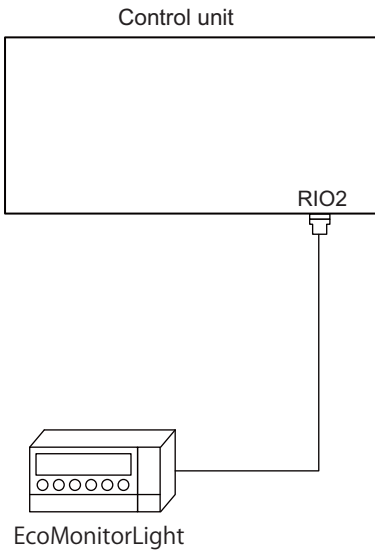

List of Configuration (M800VS/M80V Series)

3 List of Configuration (M800VS/M80V Series)

3.1 Control Unit [M800VS]

3.1 Control Unit [M800VS]

Classification	Type	Components	Remarks
NC functions and display controller For M830VS	FCU8-MU551	Base control card Add-on CPU card Front-side memory I/F card	This unit is not compliant with both Export Trade Control Order and Foreign Exchange Order.
NC functions and display controller For M850VS	FCU8-MA551	Base control card Add-on CPU card Front-side memory I/F card	This unit is not compliant with Export Trade Control Order, and it is compliant with Foreign Exchange Order.

3.2 Control Unit [M80V]

Classification	Type	Components	Remarks
NC functions and display controller For M80V Type B	FCU8-MU521	Base control card Front-side memory I/F card	This unit is not compliant with both Export Trade Control Order and Foreign Exchange Order.
NC functions and display controller For M80V Type A	FCU8-MU522	Base control card Front-side memory I/F card	This unit is not compliant with both Export Trade Control Order and Foreign Exchange Order.

3.3 Display Unit [M800VS]

Classification	Type	Components	Remarks
10.4-type color LCD touchscreen (VGA: 640 x 480)	FCU8-DU142-31	LCD panel Menu keys Escutcheon Base metal plate Cable Screw cap set	Front-side memory I/F is normally equipped with the control unit
15-type color LCD touchscreen (XGA: 1024 x 768)	FCU8-DU182-31	LCD panel Menu keys Escutcheon Base metal plate Cable Screw cap set	Front-side memory I/F is normally equipped with the control unit
19-type color LCD touchscreen (SXGA:1280 x 1024)	FCU8-DU194-31	LCD panel Menu keys Escutcheon Base metal plate Cable Screw cap set	Front-side memory I/F is normally equipped with the control unit.

3.4 Display Unit [M80V]

Classification	Type	Components	Remarks
8.4-type color LCD (VGA: 640 x 480)	FCU8-DU122-12	LCD panel Menu keys Escutcheon Base metal plate Cable Screw cap set	Front-side memory I/F is normally equipped with the control unit
10.4-type color LCD touchscreen (VGA: 640 x 480)	FCU8-DU142-32	LCD panel Menu keys Escutcheon Base metal plate Cable Screw cap set	Front-side memory I/F is normally equipped with the control unit
15-type color LCD touchscreen (XGA: 1024 x 768)	FCU8-DU182-32	LCD panel Menu keys Escutcheon Base metal plate Cable Screw cap set	Front-side memory I/F is normally equipped with the control unit
19-type color LCD touchscreen (SXGA: 1280 x 1024)	FCU8-DU194-32	LCD panel Menu keys Escutcheon Base metal plate Cable Screw cap set	Front-side memory I/F is normally equipped with the control unit.

3.5 Keyboard Unit [M800VS]

Classification	Type	Components	Remarks
Keyboard for 10.4-type display unit Clear key	FCU8-KB041	Escutcheon, key switch G402 cable Screw cap set	ONG layout (for L system, XZF)
Keyboard for 10.4-type display unit Clear key	FCU8-KB046	Escutcheon, key switch G402 cable Screw cap set	ONG layout (for M system/L system, XYZ)
Keyboard for 10.4-type display unit Clear key	FCU8-KB047	Escutcheon, key switch G402 cable Screw cap set	Full keyboard (for M system/L system) (in tandem)
Keyboard for 10.4-type display unit Clear key	FCU8-KB048	Escutcheon, key switch G402 cable Screw cap set	ABC layout (for M system/L system)
Keyboard for 15-type display unit Clear key	FCU8-KB083	Escutcheon, key switch G402 cable Screw cap set	Full keyboard (for M system/L system) (in tandem)
Keyboard for 19-type display unit	FCU8-KB091	Escutcheon, key switch G402 cable Screw cap set	Full keyboard (QWERTY layout) (in tandem)

3.6 Keyboard Unit [M80V]

Classification	Type	Components	Remarks
Keyboard for 8.4-type display unit Clear key	FCU8-KB026	Escutcheon, key switch G402 cable Screw cap set	ONG layout (for M system/L system, XYZ)
Keyboard for 8.4-type display unit Clear key	FCU8-KB028	Escutcheon, key switch G402 cable Screw cap set	ONG layout (for L system, XZF)
Keyboard for 8.4-type display unit Clear key	FCU8-KB029	Escutcheon, key switch G402 cable Screw cap set	ONG layout (for M system/L system) (in tandem)
Keyboard for 10.4-type display unit Clear key	FCU8-KB041	Escutcheon, key switch G402 cable Screw cap set	ONG layout (for L system, XZF)
Keyboard for 10.4-type display unit Clear key	FCU8-KB046	Escutcheon, key switch G402 cable Screw cap set	ONG layout (for M system/L system, XYZ)
Keyboard for 10.4-type display unit Clear key	FCU8-KB047	Escutcheon, key switch G402 cable Screw cap set	Full keyboard (for M system/L system) (in tandem)
Keyboard for 10.4-type display unit Clear key	FCU8-KB048	Escutcheon, key switch G402 cable Screw cap set	ABC layout (for M system/L system)
Keyboard for 15-type display unit Clear key	FCU8-KB083	Escutcheon, key switch G402 cable Screw cap set	Full keyboard (for M system/L system) (in tandem)
Keyboard for 19-type display unit	FCU8-KB091	Escutcheon, key switch G402 cable Screw cap set	Full keyboard (QWERTY layout) (in tandem)

3 List of Configuration (M800VS/M80V Series)

3.7 Operation Panel I/O Unit

3.7 Operation Panel I/O Unit

Classification	Type	Components	Remarks
DI 24 V/0 V common input [64 points] DO Source output [48 points] AO analog output [1 point]	FCU8-DX731	Base card RIO 2.0 terminator connector (R2-TM)	DI: 64-point 24 V/0 V common type DO: 48-point source type (200 mA/point) AO: 1 point Manual pulse generator input: 2 ch Control unit I/F Keyboard unit I/F Remote I/O 2.0 I/F RIO occupied stations (fixed): 1, 3, 7 to 12, 20 to 22 RIO extensible stations: 2, 4 to 6, 13 to 19, 23 to 64
DI 24 V/0 V common input [96 points] DO Source output [64 points]	FCU8-DX750	Base card RIO 2.0 terminator connector (R2-TM)	DI: 96-point 24 V/0 V common type DO: 64-point source type (200 mA/point) Manual pulse generator input: 3 ch Control unit I/F Keyboard unit I/F Remote I/O 2.0 I/F RIO occupied stations (fixed): 1 to 3, 7 to 12, 20 to 22 RIO extensible stations: 4 to 6, 13 to 19, 23 to 64
DI 24 V/0 V common input [96 points] DO Source output [96 points]	FCU8-DX760	Base card Add-on card RIO 2.0 terminator connector (R2-TM)	DI: 96-point 24 V/0 V common type DO: 96-point source type (200 mA/point) Manual pulse generator input: 3 ch Control unit I/F Keyboard unit I/F Remote I/O 2.0 I/F RIO occupied stations (fixed): 1 to 4, 7 to 12, 20 to 22 RIO extensible stations: 5, 6, 13 to 19, 23 to 64
DI 24 V/0 V common input [96 points] DO Source output [64 points] AI Analog input [1 point] AO Analog output [1 point]	FCU8-DX761	Base card Add-on card RIO 2.0 terminator connector (R2-TM)	DI: 96-point 24 V/0 V common type DO: 64-point source type (200 mA/point) AI: 1 point AO: 1 point Manual pulse generator input: 3 ch Control unit I/F Keyboard unit I/F Remote I/O 2.0 I/F RIO occupied stations (fixed): 1 to 5, 7 to 12, 20 to 22 RIO extensible stations: 6, 13 to 19, 23 to 64
DI 24 V/0 V common input [64 points] DO Source output [64 points] Scan input [64 points] Scan output [64 points]	FCU8-DX834	Base card Add-on card RIO 2.0 terminator connector (R2-TM)	DI: 64-point 24 V/0 V common type DO: 64-point source type (200 mA/point) Scan input: 64 points Scan output: 64 points Manual pulse generator input: 3ch Keyboard unit I/F Remote I/O 2.0 I/F RIO occupied stations (fixed): 1 to 4, 7 to 14, 20 to 22 RIO extensible stations: 5, 6, 15 to 19, 23 to 64

- ♦ DI: Digital input signals, DO: Digital output signals

3.8 Remote I/O Unit

Classification	Type	Components	Remarks
DI 24 V/0 V common input [32 points] DO Source output [32 points]	FCU8-DX220	Base card RIO 2.0 connector set	DI: 32-point 24 V/0 V common type DO: 32-point source type (200 mA/point) Number of occupied stations: 1
DI 24 V/0 V common input [64 points] DO Source output [48 points]	FCU8-DX230	Base card RIO 2.0 connector set	DI: 64-point 24 V/0 V common type DO: 48-point source type (200 mA/point) Number of occupied stations: 2
DI 24 V/0 V common input [64 points] DO Source output [48 points] AO analog output [1 point]	FCU8-DX231	Base card RIO 2.0 connector set	DI: 64-point 24 V/0 V common type DO: 48-point source type (200 mA/point) AO: 1 point Number of occupied stations: 2
AI analog input [4 points] AO analog output [1 point]	FCU8-DX202	Base card RIO 2.0 connector set	AI: 4 points AO: 1 point Number of occupied stations: 1
DI 0 V common input [16 points] DO Source output (large capacity) [8 points]	FCU8-DX213	Base card RIO 2.0 connector set	DI: 16-point 0 V common type (3 mA/point) DO: 8-point source type (2 A/point) Number of occupied stations: 1
DI 0 V common input [16 points] DO Source output (large capacity) [8 points]	FCU8-DX213-1	Base card RIO 2.0 connector set	DI: 16-point 0 V common type (9 mA/point) DO: 8-point source type (2 A/point) Number of occupied stations: 1
Safety DI 0 V common input [8 points] Safety DO Source output (large capacity) [4 points]	FCU8-DX654	Base card RIO 2.0 connector set	Safety DI: 8-point 0 V common type (3 mA/point) Safety DO: 4-point source type (2 A/point) Number of occupied stations: 2
Safety DI 0 V common input [8 points] Safety DO Source output (large capacity) [4 points]	FCU8-DX654-1	Base card RIO 2.0 connector set	Safety DI: 8-point 0 V common type (9 mA/point) Safety DO: 4-point source type (2 A/point) Number of occupied stations: 2
DI 24 V/0 V common input [32 points] DO Source output [32 points] Safety DI 0 V common input [8 points] (*1) Safety relay output [4 points] (*2)	FCU8-DX651	Base card Add-on card RIO 2.0 connector set	DI: 32-point 24 V/0 V common type DO: 32-point source type (200 mA/point) Safety DI: 8-point 0 V common type Safety relay: 4 points (non-voltage contact) Relay contact welding detection Number of occupied stations: 3
Thermistor input [12 points]	FCU8-DX408	Base card RIO 2.0 connector set	Thermistor input: 12 points Number of occupied stations: 3
Multi-analog input [4 points] (*3)	FCU8-DX409	Base card RIO 2.0 connector set	Multi-analog input: 4 points Number of occupied stations: 4

(*1) Safety DI uses 16 points of terminal because of the duplication wiring.

(*2) Safety relay output uses 8 points of terminal because of the duplication wiring.

(*3) Voltage input, current input, thermocouple input and resistance temperature detector input are selected for each channel.

♦ DI: Digital input signals, DO: Digital output signals, AI: Analog input signals, AO: Analog output signals

3.9 Laser I/F Unit

Classification	Type	Components	Remarks
Laser I/F unit	FCU8-DX522-001	Base card Connector set	DI: 26-point 0 V common type DO: 22-point source type (200 mA/point) PWM: 1 point Relay: 3 points (1 A/point) AI: 1 point AO: 1 point Remote I/O occupies 1 ch.

3 List of Configuration (M800VS/M80V Series)

3.10 Functional Safety Expansion Unit [M80V]

3.10 Functional Safety Expansion Unit [M80V]

Classification	Type	Components	Remarks
Functional safety expansion unit	FCU8-EX134	Add-on card	Smart safety observation

3.11 Function Expansion Unit

Classification	Type	Components	Remarks
CC-Link expansion unit	FCU8-EX561	CC-Link I/F PCB	CC-Link 1ch
PROFIBUS-DP master unit	FCU8-EX563	PROFIBUS-DP I/F PCB	PROFIBUS-DP 1ch
CC-Link IE Field Master/local unit	FCU8-EX564	Base card Add-on card	CC-Link IE Field 2 ch
EtherNet/IP scanner/adaptor unit	FCU8-EX565	Base card Add-on card	EtherNet/IP 1 ch (LAN1 only; LAN2 unavailable)
FL-net expansion unit	FCU8-EX568	Base card Add-on card	FL-net 1 ch (LAN1 only; LAN2 unavailable)
Vibration cutting expansion unit	FCU8-EX744	Base card	Vibration cutting function
Image input expansion unit	FCU8-EX752	Base card Add-on card Cable holder	19-type display function, Image input function with IPC (Image input I/F: HD-MI)

Classification	Type	Components	Remarks
Option relay unit	FCU8-EX704	Relay PCB	Function expansion unit for 1 slot
Option relay unit	FCU8-EX705	Relay PCB	Function expansion unit for 2 slots

- To use the function expansion unit, the option relay unit (FCU8-EX70x) is required.

3.12 Manual Pulse Generator

Classification	Type	Components	Remarks
5 V manual pulse generator	UFO-01-2Z9	UFO-01-2Z9 (Produced by NIDEC NEMICON)	Input: 5 VDC 100 pulse/rev
12 V manual pulse generator	HD60C	HD60C	Input: 12 VDC 25 pulse/rev

3.13 Synchronous feed encoder

Classification	Type	Components	Remarks
Synchronous feed encoder	OSE1024-3-15-68	OSE1024-3-15-68	Input: 5 VDC 1024 pulse/rev 6000 rpm, 68-square flange
Synchronous feed encoder	OSE1024-3-15-68-8	OSE1024-3-15-68-8	Input: 5 VDC 1024 pulse/rev 8000 rpm, 68-square flange
Synchronous feed encoder	OSE1024-3-15-160	OSE1024-3-15-160	Input: 5 VDC 1024 pulse/rev 6000 rpm, 160-square flange

3.14 Machine Operation Panel

Classification	Type	Components	Remarks
Main panel A (For 8.4-type/15-type display unit)	FCU8-KB921	Escutcheon, key switch Control card G054 cable, screw cap set	Mitsubishi Electric standard key layout (55 keys) (Standard specification A)
Main panel A (For 8.4-type/15-type display unit)	FCU8-KB922	Escutcheon, key switch Control card G054 cable, screw cap set	Custom specification, 55-key layout (Clear key top cover sold separately)
Main panel B (For 10.4-type display unit)	FCU8-KB923	Escutcheon, key switch Control card G054 cable, screw cap set	Mitsubishi Electric standard key layout (55 keys) (Standard specification A)
Main panel B (For 10.4-type display unit)	FCU8-KB924	Escutcheon, key switch Control card G054 cable, screw cap set	Custom specification, 55-key layout (Clear key top cover sold separately)
Main panel A (For 8.4-type/15-type display unit)	FCU8-KB925	Escutcheon, key switch Control card G054 cable, screw cap set	Mitsubishi Electric standard key layout (55 keys) (Standard specification B)
Main panel B (For 10.4-type display unit)	FCU8-KB926	Escutcheon, key switch Control card G054 cable, screw cap set	Mitsubishi Electric standard key layout (55 keys) (Standard specification B)
Sub panel A (Common for all display units)	FCU8-KB931	Escutcheon Emergency stop switch, override switch ON/OFF switch, screw cap set	Mitsubishi Electric standard switch specification (Standard specification A)
Sub panel A (Common for all display units)	FCU8-KB941	Escutcheon Emergency stop switch, override switch ON/OFF switch, screw cap set	Mitsubishi Electric standard switch specification (Standard specification B)
Clear key top set	N030C975G51/ N030C975G55	Clear key top cover (20 pieces/60 pieces)	
Set of labels for M7 standard key layout	N939A169G51	Labels for M7 standard key layout (1 sheet)	

3.15 Handy Terminal

Classification	Type	Components	Remarks
Handy terminal	HG1T-SB12UH- MK1346-L5		

3 List of Configuration (M800VS/M80V Series)

3.16 Cable Connector Sets

3.16 Cable Connector Sets

Classification	Type	Components	Remarks
General I/O (For SKIP, SIO, MPG, AIO)	FCUA-CS000	Connector (10120-3000PE, 2 pcs.) Shell kit (10320-52F0-008, 2 pcs.)	
Emergency stop connector (For EMG)	005057-9403 0016020103 x 3 pcs.	Connector (50-57-9403), Contact (0016020103, 3 pcs.)	
Connector kit for RIO 2.0 unit	RIO2 CON	Connector (1-1318119-3, 2 pcs.), Contact (1318107-1, 8 pcs.), Connector (2-178288-3), Contact (1-175218-5, 3 pcs.)	
Connector kit for laser I/F	RIOL-CON	Connector (1-1318119-3, 2 pcs.), Contact (1318107-1, 8 pcs.), Connector (2-178288-3, 2 pcs.), Contact (1-175218-5, 6 pcs.)	
24 VDC power supply connector (For DCIN)	FCUA-CN220	Connector (2-178288-3), Contact (1-175218-5, 3 pcs.)	
DI/DO connector (For operation panel I/O unit) (For remote I/O unit)	7940-6500SC x 4 pcs. 3448-7940 x 4 pcs.	Connector (7940-6500SC, 4 pcs.), Strain relief (3448-7940, 4 pcs.)	FCU8-DX731
DI connector (For operation panel I/O unit)	7950-6500SC x 2 pcs. 3448-7950 x 2 pcs.	Connector (7950-6500SC, 2 pcs.), Strain relief (3448-7950, 2 pcs.)	FCU8-DX750/760/761
Connector for CJ71	2-1318119-4 1318107-1 x 8 pcs.	Connector (2-1318119-4), Contact (1318107-1, 8 pcs.)	
THERMISTOR connector	37104-2165- 000FL 10P	Connector (37104-2165-000FL, 10 pcs.)	

3.17 Thermistor Set

Classification	Type	Components	Remarks
Thermistor	PT3C-51F-M2 10P	Thermistor (PT3C-51F-M2, 10 pieces)	

3.18 Genuine Memory Card

Classification	Type	Components	Remarks
Exclusive SD cards for 1 GB	FCU8-SD001G	FCU8-SD001G	1 GB capacity
Exclusive SD cards for 4 GB	FCU8-SD004G	FCU8-SD004G	4 GB capacity

3.19 Durable Parts

Durable parts	Part type
Battery for control unit	Q6BAT

- Contact the Service Center, Sales Office or dealer for repairs or part replacement.

3.20 Replacements

Replacements	Part type	Manufacturer
Protection fuse for operation panel I/O unit	LM50	Daito Communication Apparatus Co., Ltd.
Protection fuse for FCU8-DX220/230/231/651	LM50	Daito Communication Apparatus Co., Ltd.
Protection fuse for FCU8-DX213/654/213-1/654-1	MP63	Daito Communication Apparatus Co., Ltd.
Protection fuse for FCU8-DX522-001	LM50	Daito Communication Apparatus Co., Ltd.
Pair of SD/USB covers for display unit	N031C089G51	-

3.21 List of Cables

[Cable relating to NC]

Type	Application	Available cable length (m)	Max. cable length
FCUA-R050-xM	Wiring between synchronous encoder and control unit (straight, with connector)	5	30 m
FCUA-R054-xM	Wiring between synchronous encoder and control unit (right angle, with connector)	3, 5, 10, 15, 20	30 m
G071 LxM	24 VDC relay cable for machine operation panel	0.12, 0.5, 1	1 m
G123	Cable for emergency stop release	-	-
G430 LxM	Cable for connection to handy terminal	3, 5, 10	10 m
G460 LxM	Cable for machine operation panel (Cable between main panel and sub panel)	0.5	0.5 m
J010 LxM	Operation panel I/O interface cable	0.5, 1	1 m
J012 LxM	Operation panel I/O interface cable (for FCU8-DX834)	0.5, 1	1 m
J020 LxM	Manual pulse generator cable (12 V): 1 ch	1, 2, 3, 5, 7, 10, 15, 20, 30	50 m
J021 LxM	Manual pulse generator cable (12 V): 2 ch	1, 2, 3, 5, 7, 10, 15, 20, 30	50 m
J022 LxM	Manual pulse generator cable (12 V): 3 ch	1, 2, 3, 5, 7, 10, 15, 20, 30	50 m
J023 LxM	Manual pulse generator cable (5 V): 1 ch	1, 2, 3, 5, 7, 10, 15, 20	20 m
J024 LxM	Manual pulse generator cable (5 V): 2 ch	1, 2, 3, 5, 7, 10, 15, 20	20 m
J025 LxM	Manual pulse generator cable (5 V): 3 ch	1, 2, 3, 5, 7, 10, 15, 20	20 m
J026 LxM	Manual pulse generator cable (5 V): 1 ch (For connection to control unit)	1, 2, 3, 5, 7, 10, 15, 20	20 m (*)
J027 LxM	Manual pulse generator cable (5 V): 2 ch (For connection to control unit)	1, 2, 3, 5, 7, 10, 15, 20	20 m (*)
J030 LxM	RS-232C I/F cable: 1 ch	1, 2, 3, 5, 7, 10	15 m (*)
J031 LxM	RS-232C I/F cable: 2 ch	1, 2, 3, 5, 7, 10	15 m (*)
J070 LxM	24 VDC power cable	1, 2, 3, 5, 7, 10, 15	15 m
J071 LxM	24 VDC power cable (for long distance)	20	20 m
J100 LxM	SKIP input cable	1, 2, 3, 5, 7, 10, 15, 20	20 m
J120 LxM	Emergency stop cable	1, 2, 3, 5, 7, 10, 15, 20, 30	30 m
J121 LxM	Emergency stop cable for machine operation panel	1, 2, 3, 5, 7, 10, 15, 20, 30	30 m
J210 LxM	Remote I/O 2.0 communication cable	0.3, 1, 2, 3, 5, 7, 10, 15, 20, 30	50 m
J221 LxM	Analog input/output cable (for remote I/O unit)	2, 3, 7	30 m
J224 LxM	Analog input/output cable (for operation panel I/O unit)	1, 2, 3, 5, 7, 10, 15, 20	30 m
J225 LxM	Analog output cable (for operation panel I/O unit)	1, 2, 3, 5, 7, 10, 15, 20	30 m
J303 LxM	LAN straight cable	1, 2, 3, 5, 7, 10, 15, 20, 30	50 m
J350 LxM	DI/DO cable (connectors at both ends)	1, 2, 3, 5	50 m
J351 LxM	DI/DO cable (connector at one end)	3	50 m
J460 LxM	DI/DO cable (connectors at both ends)	1, 2, 3, 5	50 m
J461 LxM	DI/DO cable (connector at one end)	3	50 m
R2-TM	Terminator for remote I/O interface	-	-

Note

- (1) "x" in type columns indicate cable length (unit: m).
- (2) Lengths indicated with an asterisk (*) in the "Max. cable length" column indicate the maximum cable length when connecting via other unit.

3 List of Configuration (M800VS/M80V Series)

3.21 List of Cables

[Cable Relating to Drive Unit]

Type	Application	Available cable length (m)	Max. cable length
CNP2E-1-xM	Motor side PLG cable Spindle side accuracy encoder TS5690 cable	2, 3, 4, 5, 7, 10, 15, 20, 25, 30	30 m
CNP3EZ-2P-xM	Spindle side detector cable OSE-1024 cable	2, 3, 4, 5, 7, 10, 15, 20, 25, 30	30 m
CNP3EZ-3P-xM	Spindle side detector cable OSE-1024 cable	2, 3, 4, 5, 7, 10, 15, 20, 25, 30	30 m
CNV2E-8P-xM	For HG/HG-H, HQ-H, HK/HK-H, HG-JR Motor side encoder cable (for D47/D48/D51/D74/G48) Ball screw side encoder cable (OSA405ET2AS, OSA676ET2AS)	2, 3, 4, 5, 7, 10, 15, 20, 25, 30	30 m
CNV2E-9P-xM	For HG/HG-H, HQ-H, HK/HK-H, HG-JR Motor side encoder cable (for D47/D48/D51/D74/G48) Ball screw side encoder cable (OSA405ET2AS, OSA676ET2AS)	2, 3, 4, 5, 7, 10, 15, 20, 25, 30	30 m
MR-ENE4CBLxM-HMTH	For HG-H1502 Motor side encoder cable (for D48/D51/D74)	5, 10, 20, 30	30 m
CNV2E-D-xM	MDS-B-SD unit cable	2, 3, 4, 5, 7, 10, 15, 20, 25, 30	30 m
CNV2E-HP-xM	MDS-EX-HR unit cable	2, 3, 4, 5, 7, 10, 15, 20, 25, 30	30 m
DG30-xM	Battery cable (for wiring between drive unit and battery box, between drive units)	0.3, 0.5, 1, 2, 3, 5, 7, 10	10 m
G380 LxM	Optical communication cable Wiring between drive units (outside panel)	5, 10, 12, 15, 20, 25, 30	30 m
J395 LxM	Optical communication cable Wiring between drive units (outside panel) Wiring between NC and-drive unit	3, 5, 7, 10	10 m
J396 LxM	Optical communication cable Wiring between drive units (inside panel)	0.2, 0.3, 0.5, 1, 2, 3, 5	10 m
MR-BKS1CBLx-MA1-H	<200V Series> Brake cable for HG96 load side angle	2, 3, 5, 7, 10	10 m
MR-BKS1CBLx-MA2-H	<200V Series> Brake cable for HG96 reverse load side angle	2, 3, 5, 7, 10	10 m
MR-BT6V2CBL LxM	Battery cable (MDS-EJ/EJH) (for wiring between drive units)	0.3, 1	1 m
MR-D05UDL3M-B	STO cable	3	3 m
MR-PWS1CBLx-MA1-H	<200V Series> Power cable for HG96 load side angle	2, 3, 5, 7, 10	10 m
MR-PWS1CBLx-MA2-H	<200V Series> Power cable for HG96 reverse load side angle	2, 3, 5, 7, 10	10 m
SH21 LxM	Power supply communication cable Backup unit communication cable	0.35, 0.5, 1, 2, 3	30 m

Note

- (1) "x" in type columns indicate cable length (unit: m).
- (2) Lengths indicated with an asterisk (*) in the "Max. cable length" column indicate the maximum cable length when connecting via other unit.

3.22 System Type

Series	Model name	System type	Control unit	Display unit
M800VS Series	M850VS	FCA850H-9SV	FCU8-MA551-001	FCU8-DU194-31 (19-type color LCD touchscreen)
		FCA850H-8SV		FCU8-DU182-31 (15-type color LCD touchscreen)
		FCA850H-4SV		FCU8-DU142-31 (10.4-type color LCD touchscreen)
	M830VS	FCA830H-9SV	FCU8-MU551-001	FCU8-DU194-31 (19-type color LCD touchscreen)
		FCA830H-8SV		FCU8-DU182-31 (15-type color LCD touchscreen)
		FCA830H-4SV		FCU8-DU142-31 (10.4-type color LCD touchscreen)
M80V Series	M80V TypeA	FCA80H-9AV	FCU8-MU522-001	FCU8-DU194-32 (19-type color LCD touchscreen)
		FCA80H-8AV		FCU8-DU182-32 (15-type color LCD touchscreen)
		FCA80H-4AV		FCU8-DU142-32 (10.4-type color LCD touchscreen)
		FCA80P-2AV		FCU8-DU122-12 (8.4-type color LCD)
	M80V TypeB	FCA80H-9BV	FCU8-MU521-001	FCU8-DU194-32 (19-type color LCD touchscreen)
		FCA80H-8BV		FCU8-DU182-32 (15-type color LCD touchscreen)
		FCA80H-4BV		FCU8-DU142-32 (10.4-type color LCD touchscreen)
		FCA80P-2BV		FCU8-DU122-12 (8.4-type color LCD)

General Specifications (M800VS/M80V Series)

4.1 Environment Conditions [M800VS]

4.1.1 Installation Environment Conditions

Item	Unit name		Control unit	Display unit	
	Type		FCU8-MU551/MA551	FCU8-DU142-31: (10.4-type) FCU8-DU182-31: (15-type) FCU8-DU194-31: (19-type)	
General specifications	Ambient temperature	During operation	0 °C to 58 °C		
		During storage	-20 °C to 60 °C		
	Ambient humidity	Long term	10% to 75% RH (with no dew condensation)		
		Short term	10% to 95% RH (with no dew condensation) (*1)		
	Vibration resistance		4.9 m/s ² or less		
	Shock resistance		29.4 m/s ² or less		
	Working atmosphere		No corrosive gases, dust or oil mist		
	Altitude		Operation/Storage: 1000 meters or less above sea level, Transportation: 13000 meters or less above sea level		
	Power supply voltage		24 VDC	FCU8-DU142-31: 12 VDC/5 VDC/3.3 VDC FCU8-DU182-31: 12 VDC/5 VDC/3.3 VDC FCU8-DU194-31: 12 VDC/5 VDC/3.3 VDC (Supply from control unit)	
	Current consumption		2.5 A	- (*2)	
	Maximum heating value	(W)	16	FCU8-DU142-31: 10 FCU8-DU182-31: 14 FCU8-DU194-31: 33	
	Mass	(kg)	1.1	FCU8-DU142-31: 1.7 FCU8-DU182-31: 4.1 FCU8-DU194-31: 5.5	
	Outline dimensions W × H or W × H × D	(mm)	239.1 × 173.4 × 75	FCU8-DU142-31: 290 × 220 FCU8-DU182-31: 400 × 320 FCU8-DU194-31: 475 × 400	

(*1) "Short term" means roughly within one month.

(*2) The current consumption of the display unit is included in that of the control unit.

Note

(1) For the whole NC system, consider the characteristics of the drive units when the altitude is more than 1000 meters above sea level.

Refer to the manual of drive unit for details.

(2) When the display unit is mounted on an incline, the inclination angle to place the unit should be 30 degrees or less from the vertical direction.

4 General Specifications (M800VS/M80V Series)

4.1 Environment Conditions [M800VS]

Item	Unit name		Keyboard unit	Operation panel I/O unit		Machine operation panel	
	Type		FCU8-KB041/KB046: (10.4-type) FCU8-KB047: (10.4-type/vertical arrangement) FCU8-KB048: (10.4-type) FCU8-KB083: (15-type/vertical arrangement) FCU8-KB091: (19-type/vertical arrangement)	FCU8-DX731 FCU8-DX750 FCU8-DX760 FCU8-DX761	FCU8-DX834	FCU8-KB921/KB922/ KB925 FCU8-KB923/KB924/ KB926 FCU8-KB931/KB941	
General specifications	Ambient temperature	During operation	0 °C to 58 °C				
		During storage	-20 °C to 60 °C				
	Ambient humidity	Long term	10% to 75% RH (with no dew condensation)				
		Short term	10% to 95% RH (with no dew condensation) (*1)				
	Vibration resistance		4.9 m/s ² or less				
	Shock resistance		29.4 m/s ² or less				
	Working atmosphere		No corrosive gases, dust or oil mist				
	Altitude		Operation/Storage: 1000 meters or less above sea level, Transportation: 13000 meters or less above sea level				
	Power supply voltage		5 VDC (Supply from control unit)	5 VDC/3.3 VDC	24 VDC	24 VDC (*4)	
	Current consumption		- (*2)		0.3 A (*5)	0.3 A (*4)	
	Maximum heating value	(W)	1	4 (*3)	8 (*3)	7.2	
	Mass	(kg)	FCU8-KB041/KB046: 0.8 FCU8-KB047: 1.3 FCU8-KB048: 1.4 FCU8-KB083: 1.5 FCU8-KB091: 1.6	FCU8-DX731: 0.3 FCU8-DX750: 0.4 FCU8-DX760: 0.5 FCU8-DX761: 0.5	0.4	FCU8-KB921/KB922/ KB925: 1.1 FCU8-KB923/KB924/ KB926: 1.2 FCU8-KB931/KB941: 0.5	
	Outline dimensions W × H	(mm)	FCU8-KB041/KB046: 140 × 220 FCU8-KB047: 290 × 160 FCU8-KB048: 230 × 220 FCU8-KB083: 400 × 140 FCU8-KB091: 475 × 120	116 × 179		FCU8-KB921/KB922/ KB925: 260 × 140 FCU8-KB923/KB924/ KB926: 290 × 140 FCU8-KB931/KB941: 140 × 140	

(*1) "Short term" means roughly within one month.

(*2) The current consumption of the keyboard unit and the operation panel I/O unit (control section) are included in that of the control unit. Current consumption for the I/O circuit needs to be separately calculated based on the number of points used and its load.

(*3) For the heating value of the I/O circuit, calculate with the number of points used.

(*4) 24 V power input is not required for FCU8-KB931/KB941.

(*5) Current consumption for the I/O circuit needs to be separately calculated based on the number of points used and its load.

Note

(1) For the whole NC system, consider the characteristics of the drive units when the altitude is more than 1000 meters above sea level.

Refer to the manual of drive unit for details.

4 General Specifications (M800VS/M80V Series)

4.1 Environment Conditions [M800VS]

Item	Unit name		Remote I/O unit					
	Type		FCU8-DX220/ DX230/DX231	FCU8-DX202	FCU8-DX213/ DX213-1/ DX654/ DX654-1	FCU8-DX408	FCU8-DX409	FCU8-DX651
General specifications	Ambient temperature	During operation	0 °C to 58 °C					
		During storage	-20 °C to 60 °C					
	Ambient humidity	Long term	10% to 75% RH (with no dew condensation)					
		Short term	10% to 95% RH (with no dew condensation) (*1)					10% to 85% RH (with no dew condensation) (*1)
	Vibration resistance		4.9 m/s ² or less					
	Shock resistance		29.4 m/s ² or less					
	Working atmosphere		No corrosive gases, dust or oil mist					
	Altitude		Operation/Storage: 1000 meters or less above sea level, Transportation: 13000 meters or less above sea level					
	Power supply voltage		24 VDC					
	Current consumption		3.5 A (*2)	0.3 A	0.3 A (*3)	0.1 A	0.2 A	3.7 A (*2)
	Maximum heating value	(W)	8 (*4)			3	6 (*5)	8 (*4)
	Mass	(kg)	0.4			0.2	0.3	0.8
	Outline dimensions W × H × D	(mm)	40 × 175 × 133	40 × 175 × 119	40 × 175 × 130	40 × 175 × 109	40 × 175 × 130	104 × 175 × 115

(*1) "Short term" means roughly within one month.

(*2) This value includes the maximum value of DO external load current (3.2 A).

(*3) This value does not include DO external load current.

(*4) For the heating value of the I/O circuit, calculate with the number of points used.

(*5) The maximum value including the heating value of analog input circuit.

Note

(1) For the whole NC system, consider the characteristics of the drive units when the altitude is more than 1000 meters above sea level.

Refer to the manual of drive unit for details.

4 General Specifications (M800VS/M80V Series)

4.1 Environment Conditions [M800VS]

Item	Unit name		Laser I/F unit
	Type		FCU8-DX522-001
General specifications	Ambient temperature	During operation	0 °C to 58 °C
		During storage	-20 °C to 60 °C
	Ambient humidity	Long term	10% to 75% RH (with no dew condensation)
		Short term	10% to 95% RH (with no dew condensation) (*1)
	Vibration resistance		4.9 m/s ² or less
	Shock resistance		29.4 m/s ² or less
	Working atmosphere		No corrosive gases, dust or oil mist
	Altitude		Operation/Storage: 1000 meters or less above sea level, Transportation: 13000 meters or less above sea level
	Power supply voltage		24 VDC
	Current consumption		0.3 A (*2)
	Maximum heating value	(W)	8 (*3)(*4)
	Mass	(kg)	0.4
	Outline dimensions W × H × D	(mm)	40 × 175 × 133

(*1) "Short term" means roughly within one month.

(*2) This value does not include DO external load current.

(*3) For the heating value of the I/O circuit, calculate with the number of points used.

(*4) The maximum value including the heating value of analog input circuit.

Note

(1) For the whole NC system, consider the characteristics of the drive units when the altitude is more than 1000 meters above sea level.

Refer to the manual of drive unit for details.

4.1.2 24 VDC Stabilized Power Supply Selecting Conditions

Consider the following characteristics for the stabilized power supply, and select the power supply that complies with laws, regulations, or safety standards of the country where the machine will be installed.

	Item	Specifications	Remarks
Output	Voltage	24 VDC	When the stabilized power supply and 24 VDC input unit are distant, select the stabilized power supply which is possible to set output voltage 24 VDC or more allowing for the influence of voltage down by the cable.
	Voltage fluctuation	±5%	
	Current	-	Calculate the current value as a reference of maximum current consumption for the unit which uses the power supply.
	Ripple noise	0.2 V (P-P)	
	Output holding time	min 20ms	Output holding time is decided by loading ratio; however, the stabilized power supply which complies with the specification on the left must be selected during maximum loading.
	Overcurrent output shutoff function	-	Use a power supply having the overcurrent output shutoff function.

CAUTION

Using a stabilized power supply without overcurrent protection may cause the unit's failure due to miswiring of 24 V.

4.2 Environment Conditions [M80V]

4.2.1 Installation Environment Conditions

Item	Unit name		Control unit	Display unit
	Type		FCU8-MU521/MU522	FCU8-DU122-12: (8.4-type) FCU8-DU142-32: (10.4-type) FCU8-DU182-32: (15-type) FCU8-DU194-32: (19-type)
General specifications	Ambient temperature	During operation	0 °C to 58 °C	
		During storage	-20 °C to 60 °C	
	Ambient humidity	Long term	10% to 75% RH (with no dew condensation)	
		Short term	10% to 95% RH (with no dew condensation) (*1)	
	Vibration resistance		4.9 m/s ² or less	
	Shock resistance		29.4 m/s ² or less	
	Working atmosphere		No corrosive gases, dust or oil mist	
	Altitude		Operation/Storage: 1000 meters or less above sea level, Transportation: 13000 meters or less above sea level	
	Power supply voltage		24 VDC	FCU8-DU122-12: 12 VDC/3.3 VDC FCU8-DU142-32: 12 VDC/5 VDC/3.3 VDC FCU8-DU182-32: 12 VDC/5 VDC/3.3 VDC FCU8-DU194-32: 12 VDC/5 VDC/3.3 VDC (Supplied from control unit)
	Current consumption		2.5 A	- (*2)
	Maximum heating value	(W)	12	FCU8-DU122-12: 8 FCU8-DU142-32: 10 FCU8-DU182-32: 14 FCU8-DU194-32: 33
	Mass	(kg)	1.1	FCU8-DU122-12: 1.2 FCU8-DU142-32: 1.7 FCU8-DU182-32: 4.1 FCU8-DU194-32: 5.5
	Outline dimensions W × H or W × H × D	(mm)	239.1 × 173.4 × 75	FCU8-DU122-12: 260 × 200 FCU8-DU142-32: 290 × 220 FCU8-DU182-32: 400 × 320 FCU8-DU194-32: 475 × 400

(*1) "Short term" means roughly within one month.

(*2) The current consumption of the display unit is included in that of the control unit.

Note

- For the whole NC system, consider the characteristics of the drive units when the altitude is more than 1000 meters above sea level.
Refer to the manual of drive unit for details.
- When the display unit is mounted on an incline, the inclination angle to place the unit should be 30 degrees or less from the vertical direction.

4 General Specifications (M800VS/M80V Series)

4.2 Environment Conditions [M80V]

Item	Unit name		Keyboard unit	Operation panel I/O unit		Machine operation panel	
		Type		FCU8-KB026/KB028: (8.4-type) FCU8-KB029: (8.4-type/vertical arrangement) FCU8-KB041/KB046: (10.4-type) FCU8-KB047: (10.4-type/vertical arrangement) FCU8-KB048: (10.4-type) FCU8-KB083: (15-type/vertical arrangement) FCU8-KB091: (19-type/vertical arrangement)	FCU8-DX731 FCU8-DX750 FCU8-DX760 FCU8-DX761	FCU8-DX834	FCU8-KB921/KB922/KB925 FCU8-KB923/KB924/KB926 FCU8-KB931/KB941
General specifications	Ambient temperature	During operation	0 °C to 58 °C				
		During storage	-20 °C to 60 °C				
	Ambient humidity	Long term	10% to 75% RH (with no dew condensation)				
		Short term	10% to 95% RH (with no dew condensation) (*1)				
	Vibration resistance		4.9 m/s ² or less				
	Shock resistance		29.4 m/s ² or less				
	Working atmosphere		No corrosive gases, dust or oil mist				
	Altitude		Operation/Storage: 1000 meters or less above sea level, Transportation: 13000 meters or less above sea level				
	Power supply voltage		5 VDC (Supply from control unit)	5 VDC/3.3 VDC	24 VDC	24 VDC (*4)	
	Current consumption		- (*2)		0.3 A (*5)	0.3 A (*4)	
	Maximum heating value	(W)	1	4 (*3)	8 (*3)	7.2	
Mass	(kg)	FCU8-KB026/KB028: 0.75 FCU8-KB029: 1.0 FCU8-KB041/KB046: 0.8 FCU8-KB047: 1.3 FCU8-KB048: 1.4 FCU8-KB083: 1.5 FCU8-KB091: 1.6	FCU8-DX731: 0.3 FCU8-DX750: 0.4 FCU8-DX760: 0.5 FCU8-DX761: 0.5	0.4	FCU8-KB921/KB922/KB925: 1.1 FCU8-KB923/KB924/KB926: 1.2 FCU8-KB931/KB941: 0.5		
Outline dimensions W × H	(mm)	FCU8-KB026/KB028: 140 × 200 FCU8-KB029: 260 × 140 FCU8-KB041/KB046: 140 × 220 FCU8-KB047: 290 × 160 FCU8-KB048: 230 × 220 FCU8-KB083: 400 × 140 FCU8-KB091: 475 × 120	116 × 179		FCU8-KB921/KB922/KB925: 260 × 140 FCU8-KB923/KB924/KB926: 290 × 140 FCU8-KB931/KB941: 140 × 140		

(*1) "Short term" means roughly within one month.

(*2) The current consumption of the keyboard unit and the operation panel I/O unit (control section) are included in that of the control unit. Current consumption for the I/O circuit needs to be separately calculated based on the number of points used and its load.

(*3) For the heating value of the I/O circuit, calculate with the number of points used.

(*4) 24 V power input is not required for FCU8-KB931/KB941.

(*5) Current consumption for the I/O circuit needs to be separately calculated based on the number of points used and its load.

Note

(1) For the whole NC system, consider the characteristics of the drive units when the altitude is more than 1000 meters above sea level.

Refer to the manual of drive unit for details.

4 General Specifications (M800VS/M80V Series)

4.2 Environment Conditions [M80V]

Item	Unit name		Remote I/O unit					
	Type		FCU8-DX220/ DX230/DX231	FCU8-DX202	FCU8-DX213/ DX213-1/ DX654/ DX654-1	FCU8-DX408	FCU8-DX409	FCU8-DX651
General specifications	Ambient temperature	During operation	0 °C to 58 °C					
		During storage	-20 °C to 60 °C					
	Ambient humidity	Long term	10% to 75% RH (with no dew condensation)					
		Short term	10% to 95% RH (with no dew condensation) (*1)				10% to 85% RH (with no dew condensation) (*1)	
	Vibration resistance		4.9 m/s ² or less					
	Shock resistance		29.4 m/s ² or less					
	Working atmosphere		No corrosive gases, dust or oil mist					
	Altitude		Operation/Storage: 1000 meters or less above sea level, Transportation: 13000 meters or less above sea level					
	Power supply voltage		24 VDC					
	Current consumption		3.5 A (*2)	0.3 A	0.3 A (*3)	0.1 A	0.2 A	3.7 A (*2)
	Maximum heating value	(W)	8 (*4)			3	6 (*5)	8 (*4)
	Mass	(kg)	0.4			0.2	0.3	0.8
	Outline dimensions W × H × D	(mm)	40 × 175 × 133	40 × 175 × 119	40 × 175 × 130	40 × 175 × 109	40 × 175 × 130	104 × 175 × 115

(*1) "Short term" means roughly within one month.

(*2) This value includes the maximum value of DO external load current (3.2 A).

(*3) This value does not include DO external load current.

(*4) For the heating value of the I/O circuit, calculate with the number of points used.

(*5) The maximum value including the heating value of analog input circuit.

Note

(1) For the whole NC system, consider the characteristics of the drive units when the altitude is more than 1000 meters above sea level.

Refer to the manual of drive unit for details.

4 General Specifications (M800VS/M80V Series)

4.2 Environment Conditions [M80V]

Item	Unit name		Laser I/F unit
	Type		FCU8-DX522-001
General specifications	Ambient temperature	During operation	0 °C to 58 °C
		During storage	-20 °C to 60 °C
	Ambient humidity	Long term	10% to 75% RH (with no dew condensation)
		Short term	10% to 95% RH (with no dew condensation) (*1)
	Vibration resistance		4.9 m/s ² or less
	Shock resistance		29.4 m/s ² or less
	Working atmosphere		No corrosive gases, dust or oil mist
	Altitude		Operation/Storage: 1000 meters or less above sea level, Transportation: 13000 meters or less above sea level
	Power supply voltage		24 VDC
	Current consumption		0.3 A (*2)
	Maximum heating value	(W)	8 (*3)(*4)
	Mass	(kg)	0.4
Outline dimensions W × H × D	(mm)	40 × 175 × 133	

(*1) "Short term" means roughly within one month.

(*2) This value does not include DO external load current.

(*3) For the heating value of the I/O circuit, calculate with the number of points used.

(*4) The maximum value including the heating value of analog input circuit.

Note

(1) For the whole NC system, consider the characteristics of the drive units when the altitude is more than 1000 meters above sea level.

Refer to the manual of drive unit for details.

4.2.2 24 VDC Stabilized Power Supply Selecting Conditions

Consider the following characteristics for the stabilized power supply, and select the power supply that complies with laws, regulations, or safety standards of the country where the machine will be installed.

	Item	Specifications	Remarks
Output	Voltage	24 VDC	When the stabilized power supply and 24 VDC input unit are distant, select the stabilized power supply which is possible to set output voltage 24 VDC or more allowing for the influence of voltage down by the cable.
	Voltage fluctuation	±5%	
	Current	-	Calculate the current value as a reference of maximum current consumption for the unit which uses the power supply.
	Ripple noise	0.2 V (P-P)	
	Output holding time	min 20ms	Output holding time is decided by loading ratio; however, the stabilized power supply which complies with the specification on the left must be selected during maximum loading.
	Overcurrent output shutoff function	-	Use a power supply having the overcurrent output shutoff function.

CAUTION

Using a stabilized power supply without overcurrent protection may cause the unit's failure due to miswiring of 24 V.

4.3 Control Unit [M800VS]

4.3.1 FCU8-MU551 / FCU8-MA551

Outline dimensions

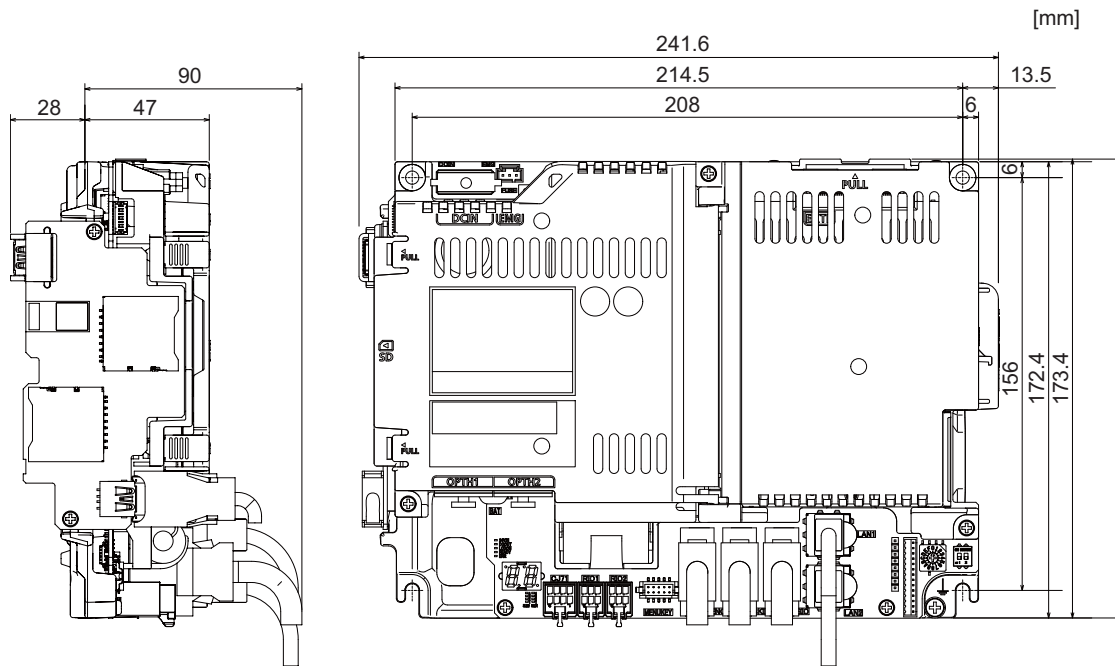

4.4 Control Unit [M80V]

4.4.1 FCU8-MU521 / FCU8-MU522

Outline dimensions

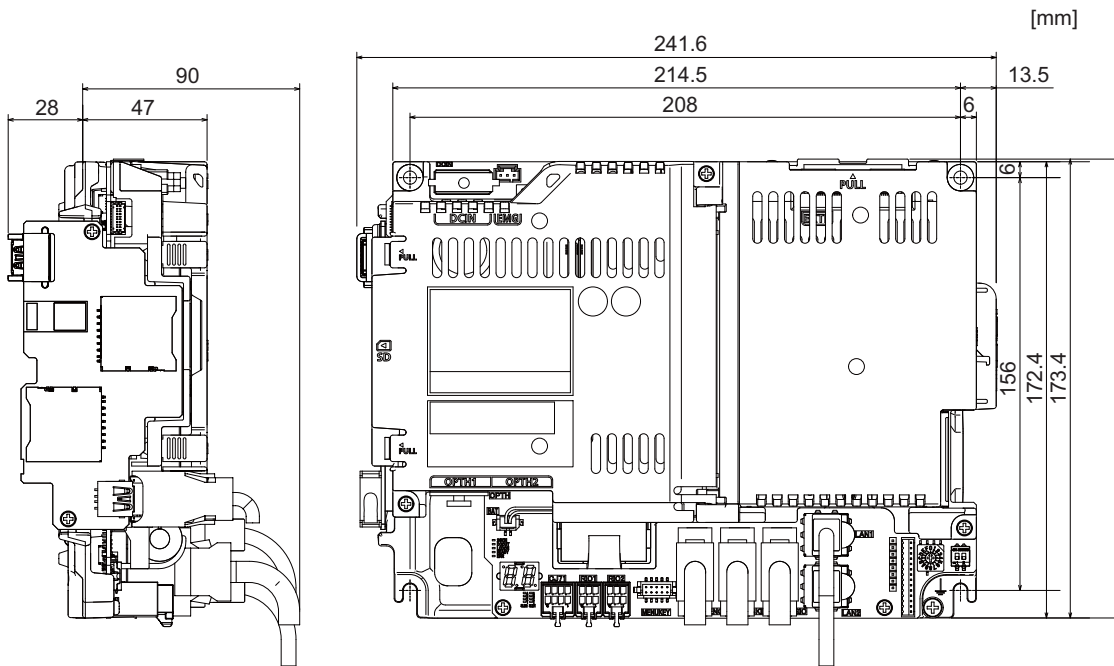

4.5 Display Unit [M800VS]

4.5.1 10.4-type (FCU8-DU142-31)

Outline dimensions

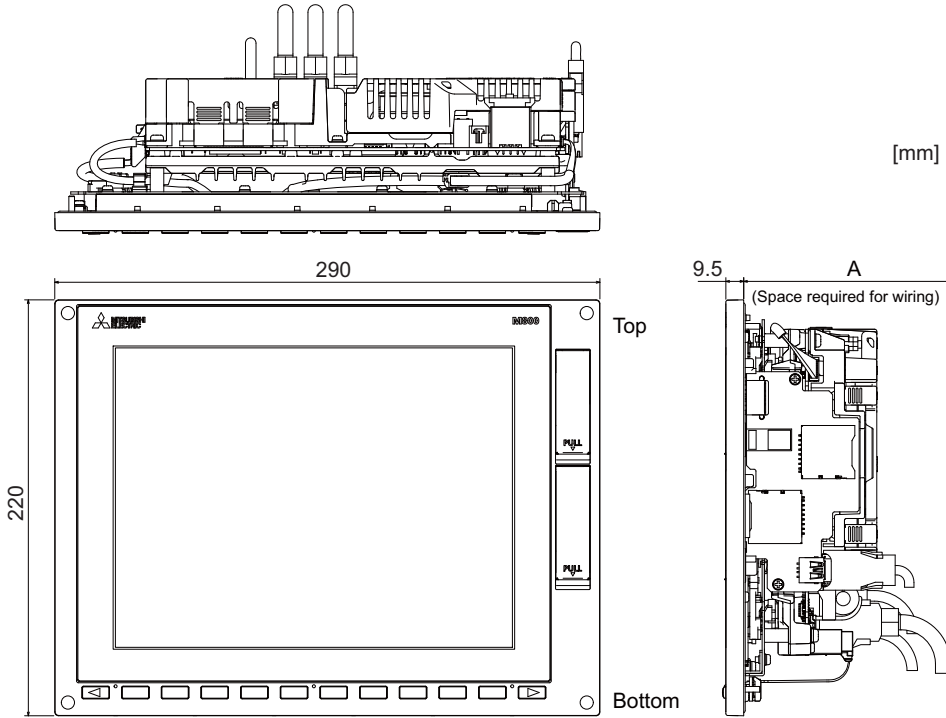

	Option relay unit not mounted	Option relay unit FCU8-EX704 mounted	Option relay unit FCU8-EX705 mounted
A (Space required for wiring)	110	114	114

Note

(1) The figure above shows the state with the control unit mounted.

Panel cut dimensions

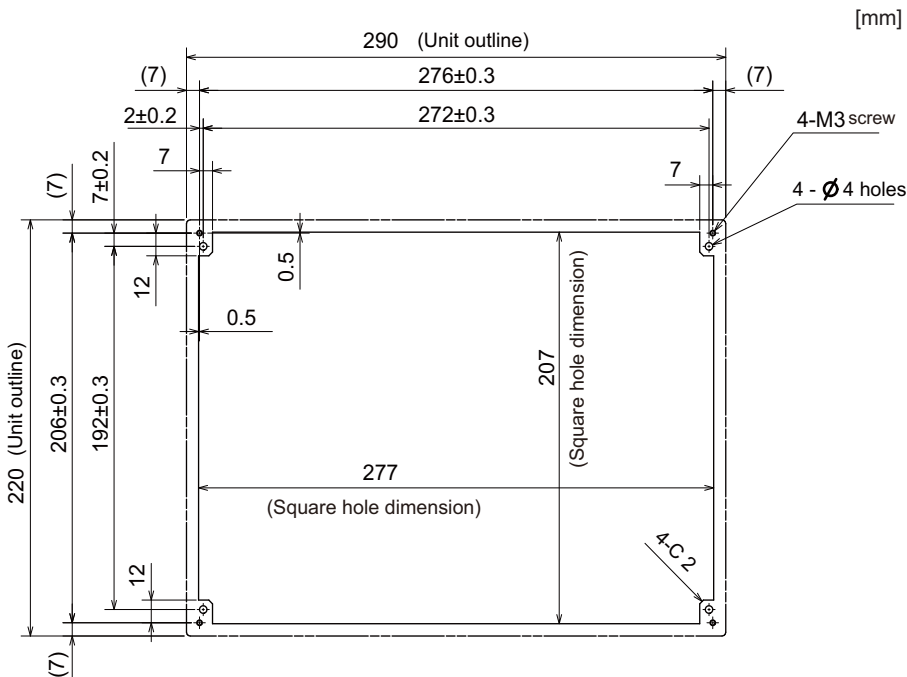

4.5.2 15-type (FCU8-DU182-31)

Outline dimensions

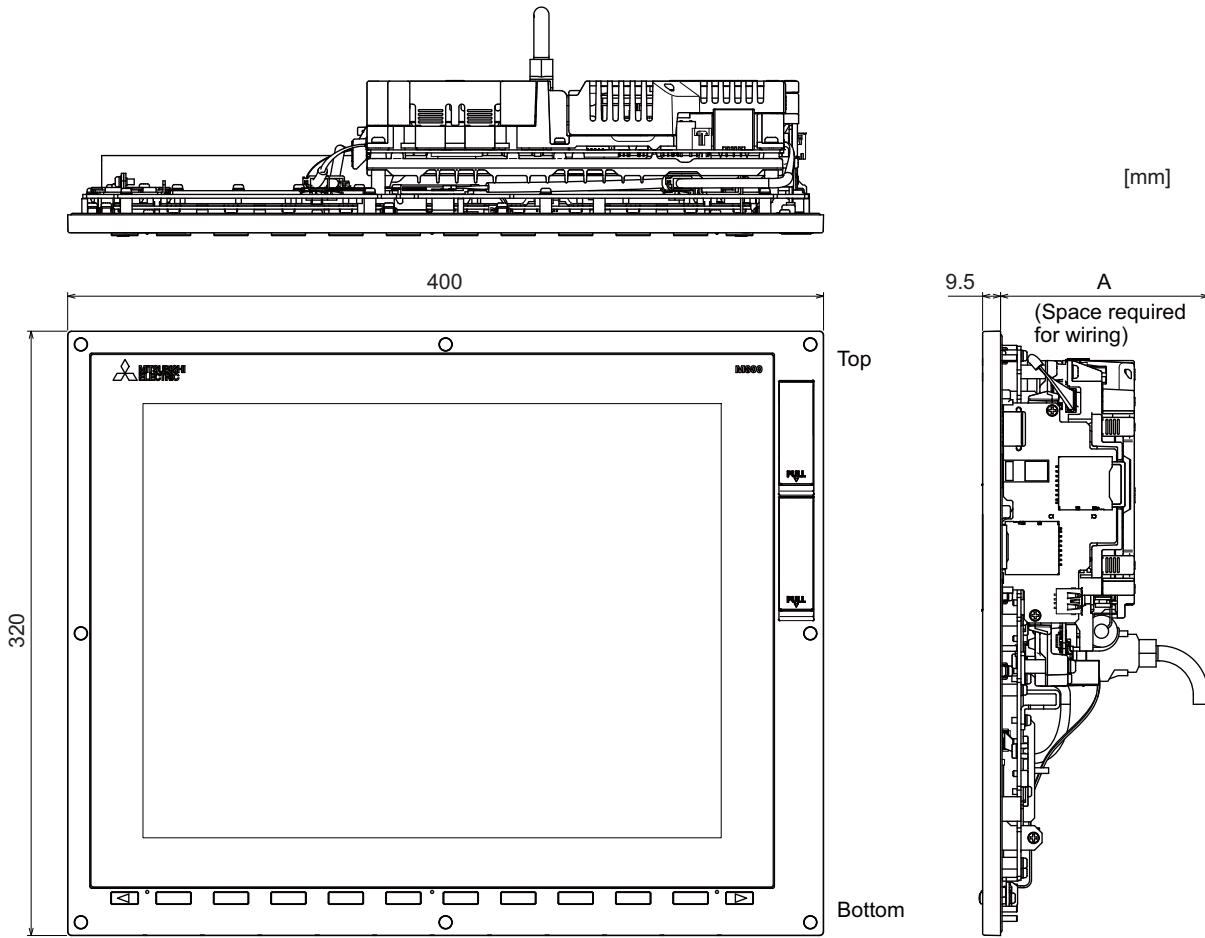

	Option relay unit not mounted	Option relay unit FCU8-EX704 mounted	Option relay unit FCU8-EX705 mounted
A (Space required for wiring)	110	114	114

Note

(1) The figure above shows the state with the control unit mounted.

Panel cut dimensions

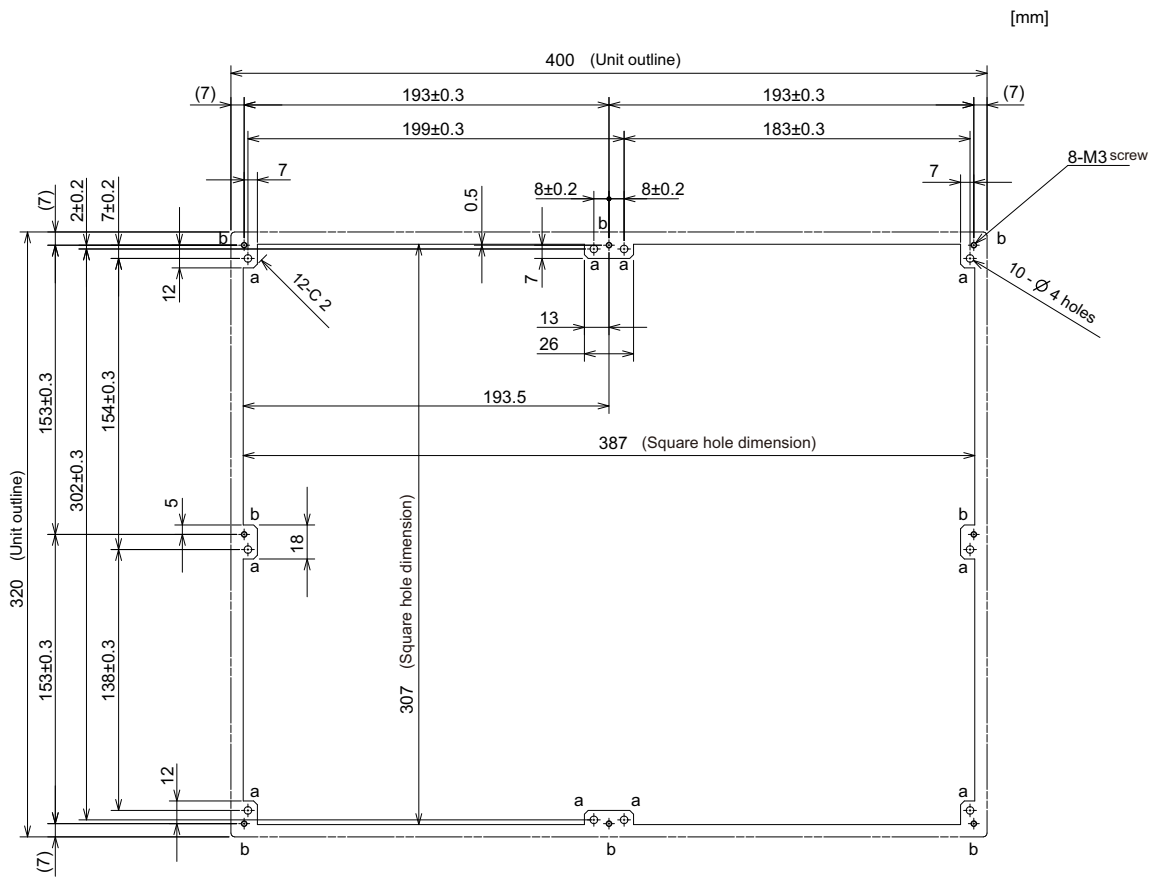

4.5.3 19-type (FCU8-DU194-31)

Outline dimensions

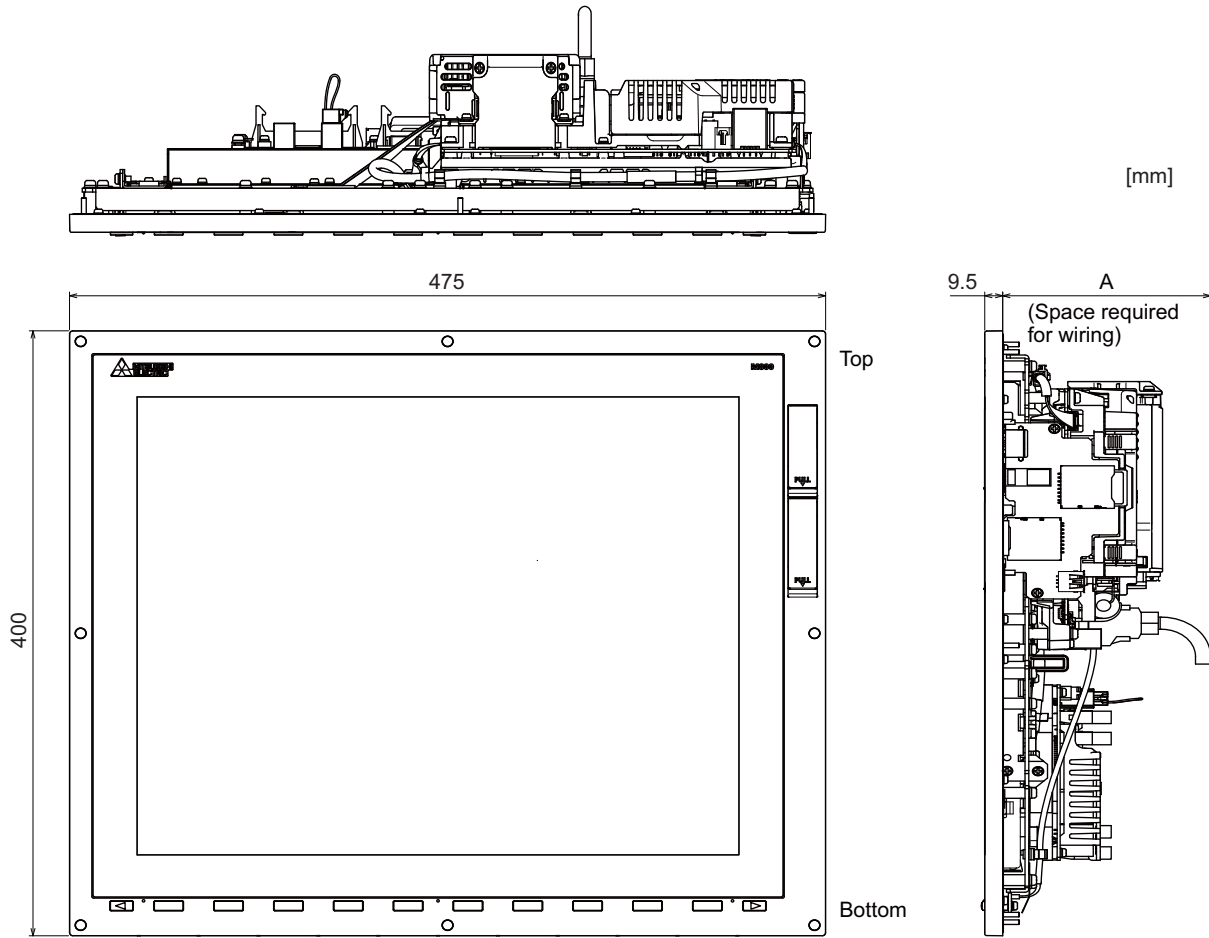

	Option relay unit not mounted	Option relay unit FCU8-EX704 mounted	Option relay unit FCU8-EX705 mounted
A (Space required for wiring)	110	114	

Note

(1) The figure above shows the state with the control unit mounted.

Panel cut dimensions

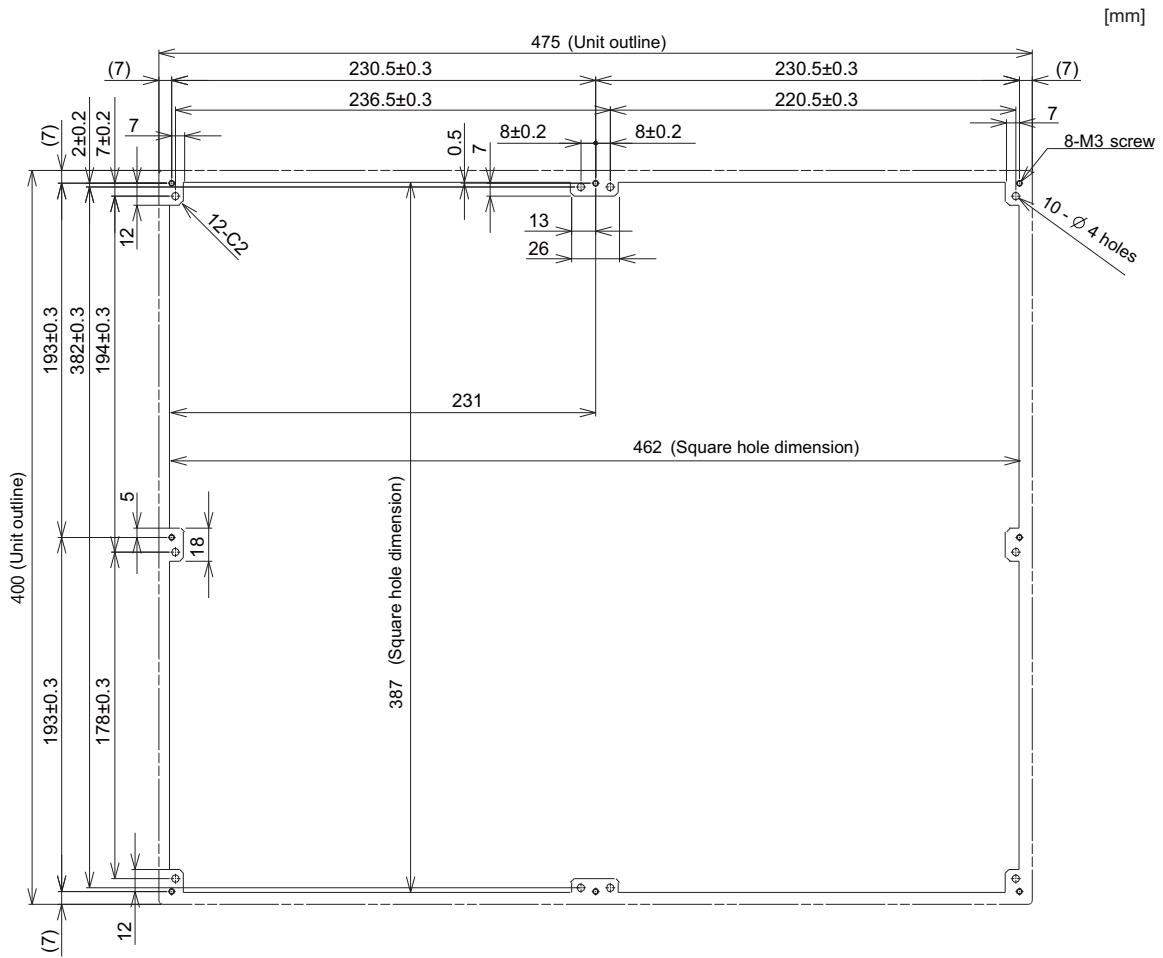

4.6 Display Unit [M80V]

4.6.1 8.4-type (FCU8-DU122-12)

Outline dimensions

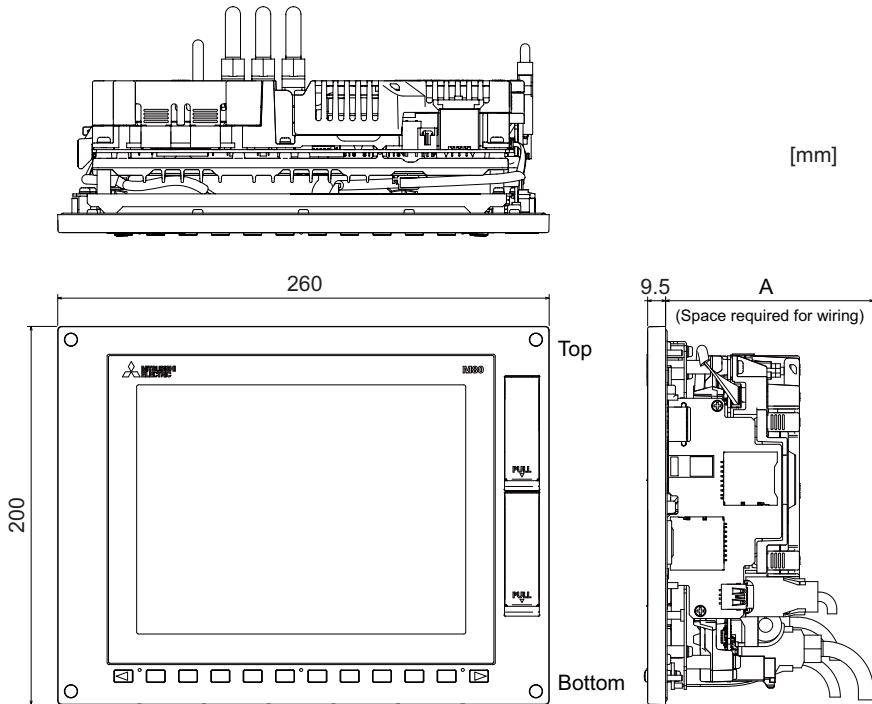

	Option relay unit not mounted	Option relay unit FCU8-EX704 mounted	Option relay unit FCU8-EX705 mounted
A (Space required for wiring)	110	114	114

Note

- (1) The 8.4-type display unit is incompatible with the touchscreen.
- (2) The figure above shows the state with the control unit mounted.

Panel cut dimensions

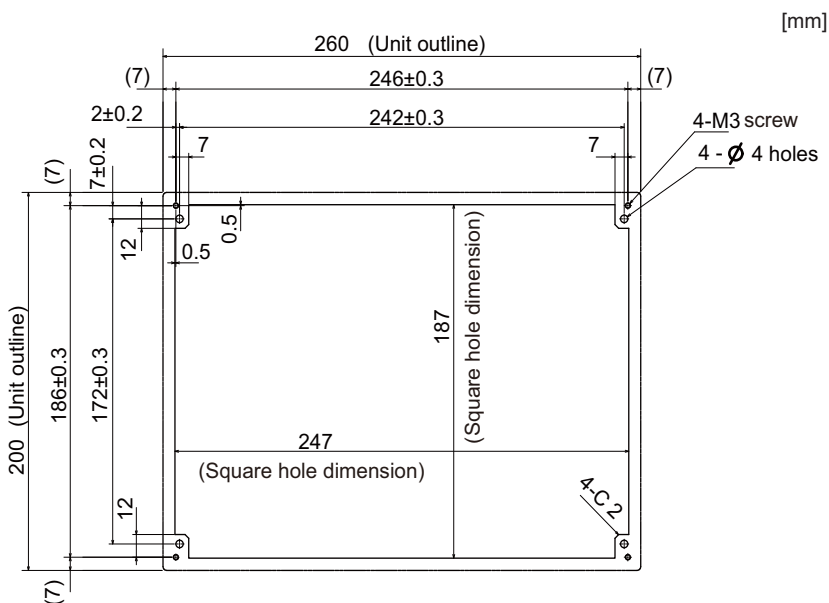

4.6.2 10.4-type (FCU8-DU142-32)

Outline dimensions

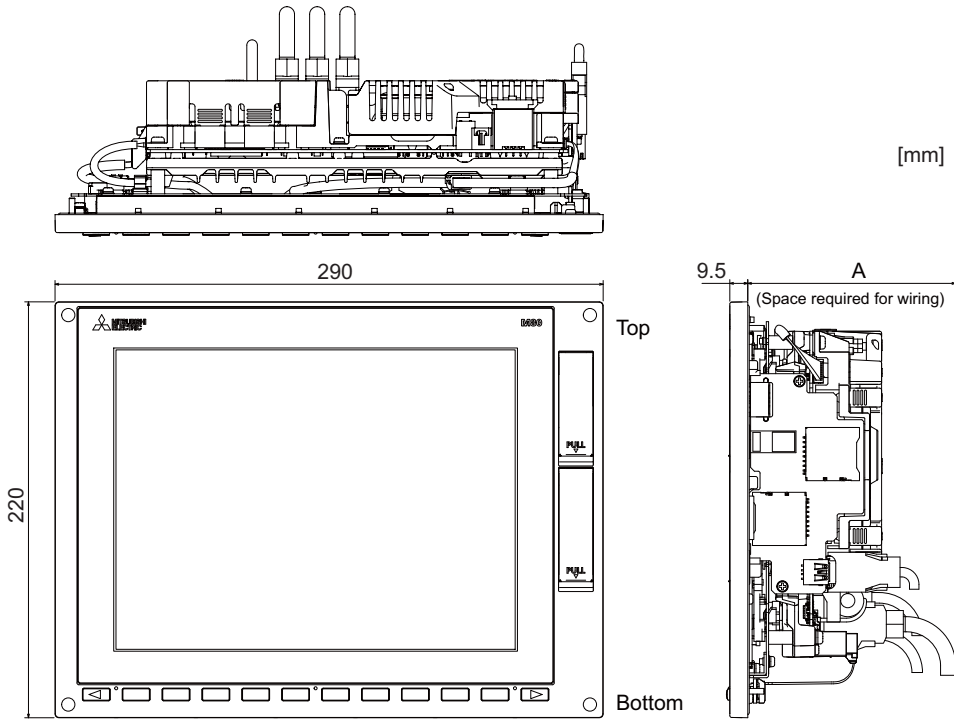

	Option relay unit not mounted	Option relay unit FCU8-EX704 mounted	Option relay unit FCU8-EX705 mounted
A (Space required for wiring)	110		114

Note

(1) The figure above shows the state with the control unit mounted.

Panel cut dimensions

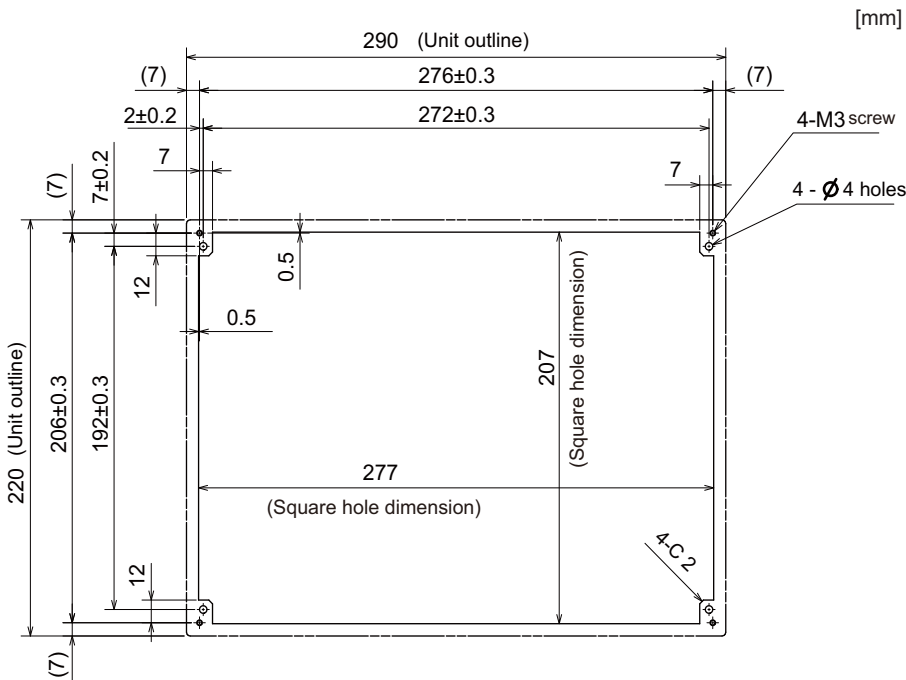

4.6.3 15-type (FCU8-DU182-32)

Outline dimensions

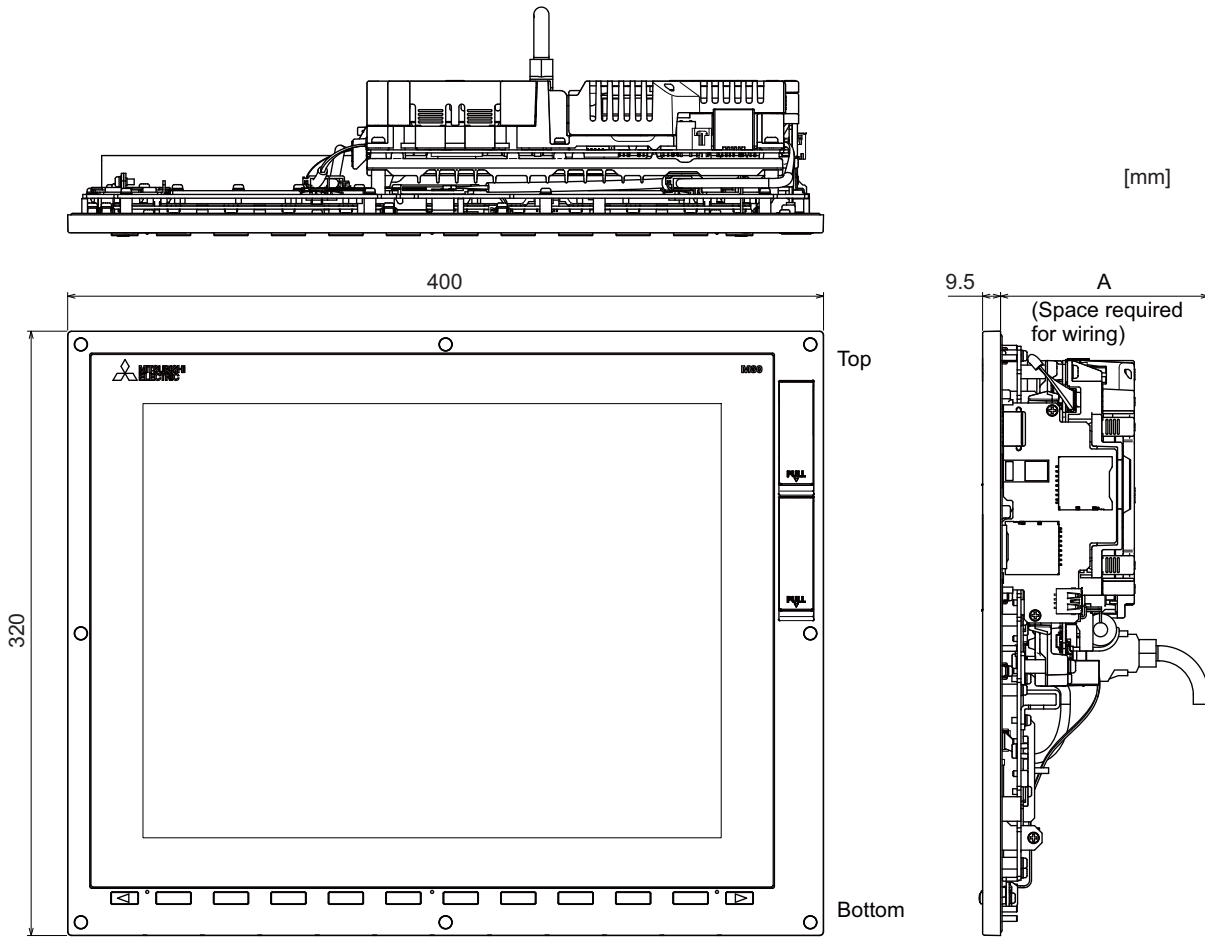

	Option relay unit not mounted	Option relay unit FCU8-EX704 mounted	Option relay unit FCU8-EX705 mounted
A (Space required for wiring)	110	114	114

Note

(1) The figure above shows the state with the control unit mounted.

Panel cut dimensions

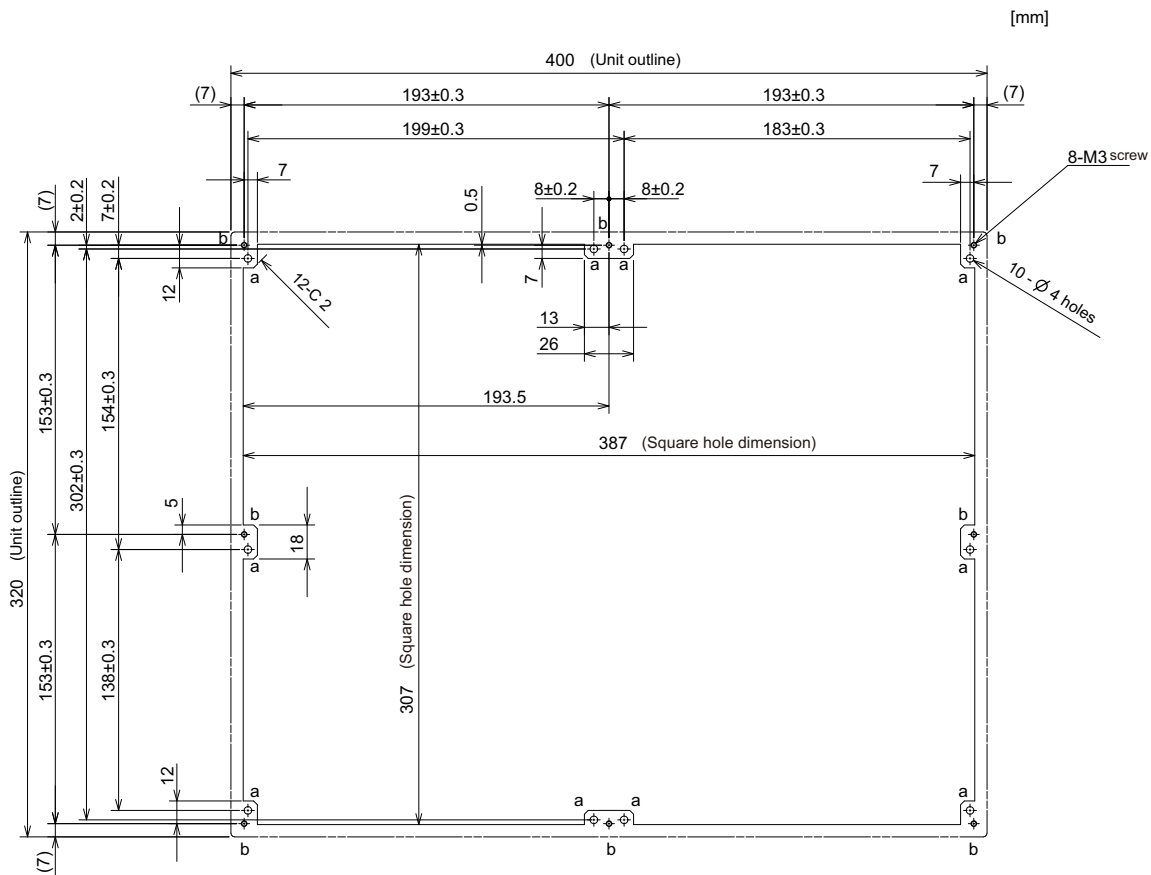

4.6.4 19-type (FCU8-DU194-32)

Outline dimensions

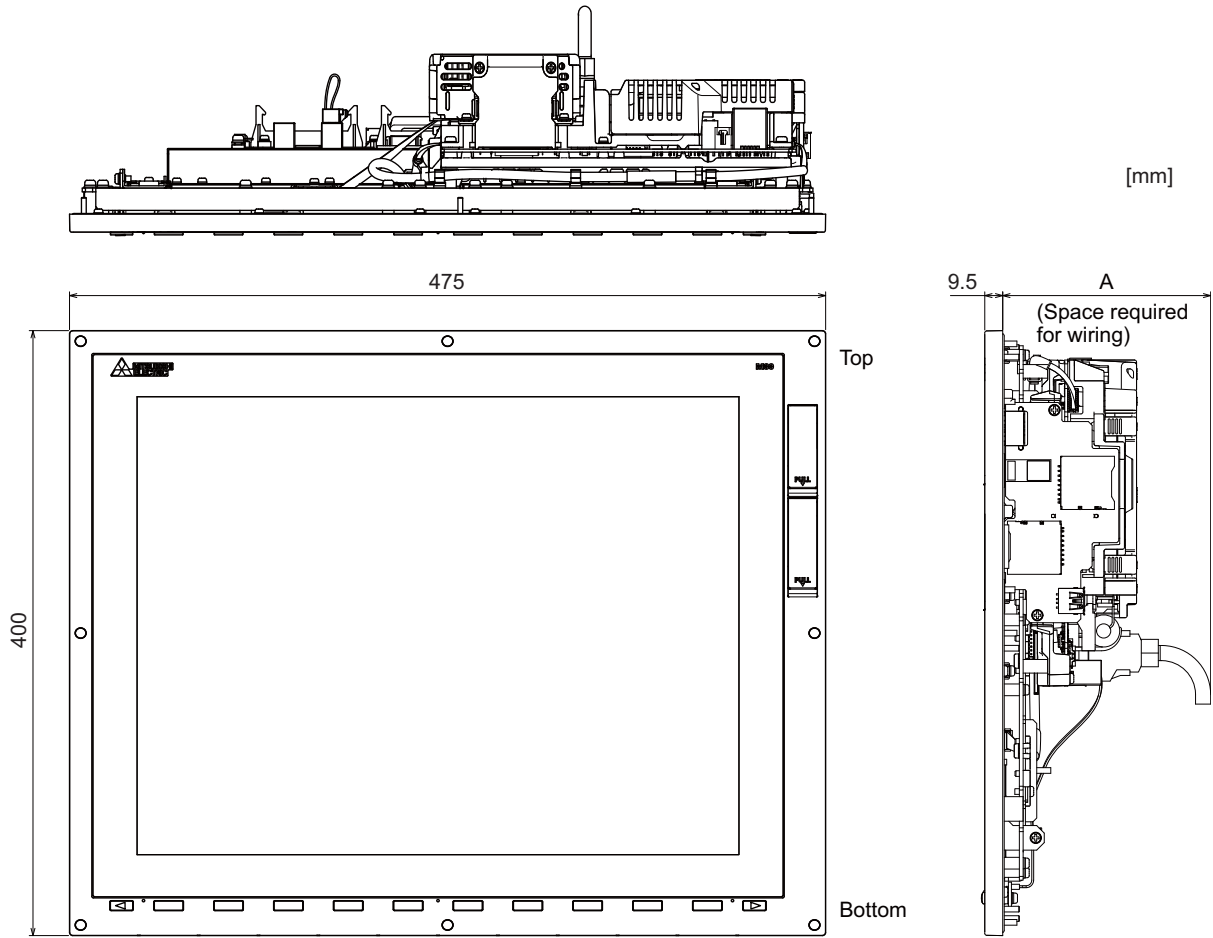

	Option relay unit not mounted	Option relay unit FCU8-EX704 mounted	Option relay unit FCU8-EX705 mounted
A (Space required for wiring)	110	114	114

Note

(1) The figure above shows the state with the control unit mounted.

Panel cut dimensions

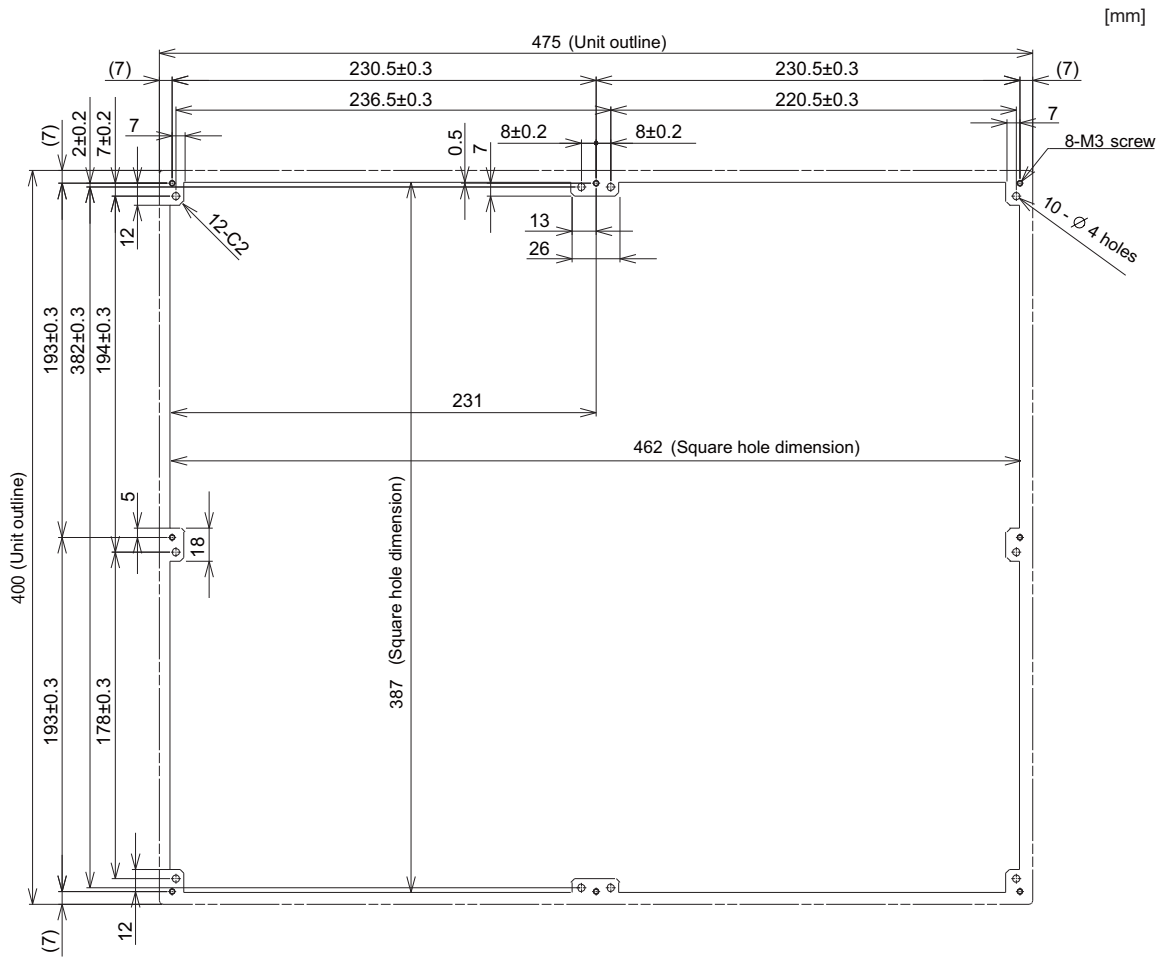

4.7 Keyboard Unit

Note

- (1) Do not change the setting for the rotary switch mounted on the keyboard unit.
If the setting is changed, the keyboard will not work.

Type name	The initial value of the rotary switch
FCU8-KB026	1
FCU8-KB028	3
FCU8-KB029	0
FCU8-KB041	2
FCU8-KB046	0
FCU8-KB047	0
FCU8-KB048	0
FCU8-KB083	A
FCU8-KB091	0

4.7.1 Keyboard for 8.4-type Display Unit (FCU8-KB026)

Outline dimensions

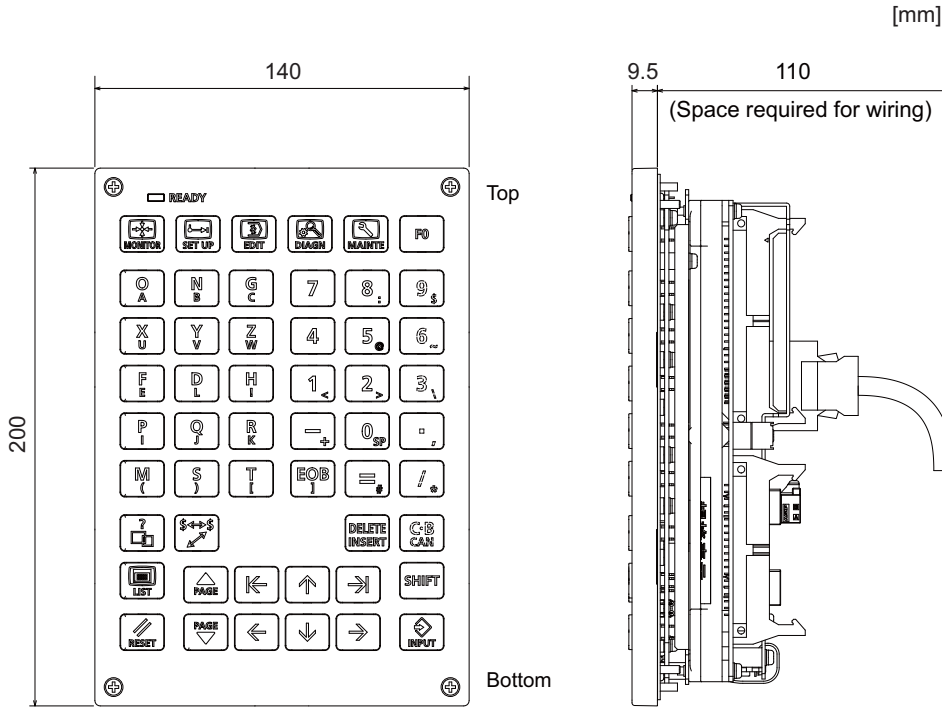

Note

(1) The above side view shows the state with the operation panel I/O unit mounted.

Panel cut dimensions

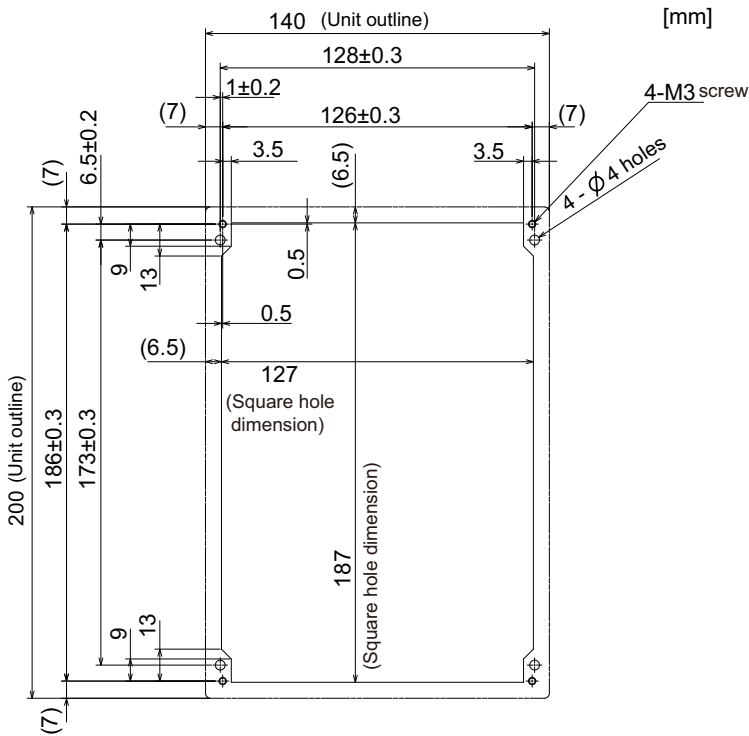

4.7.2 Keyboard for 8.4-type Display Unit (FCU8-KB028)

Outline dimensions

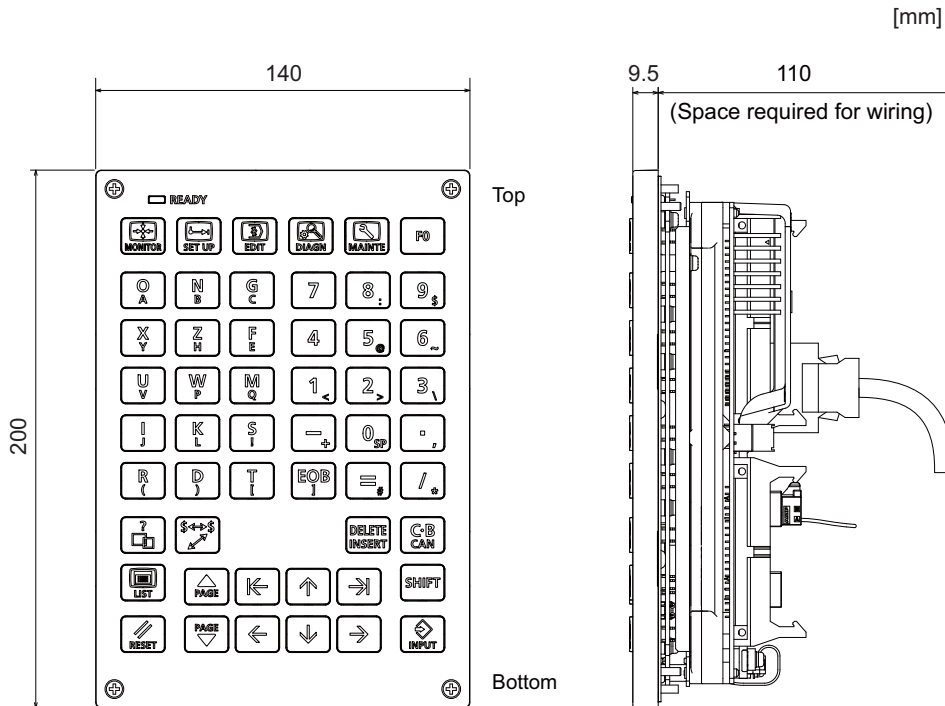

Note

(1) The above side view shows the state with the operation panel I/O unit mounted.

Panel cut dimensions

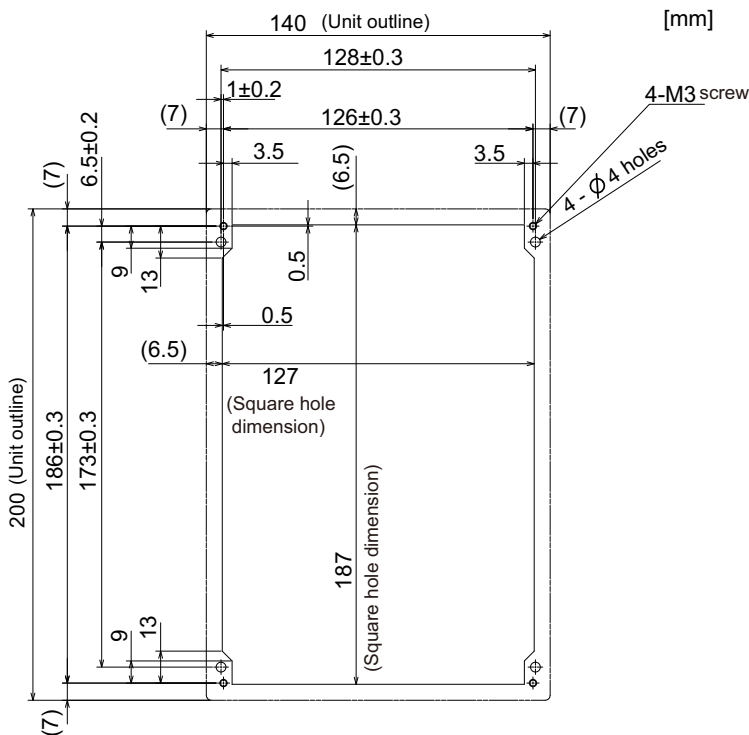

4.7.3 Keyboard for 8.4-type Display Unit (FCU8-KB029)

Outline dimensions

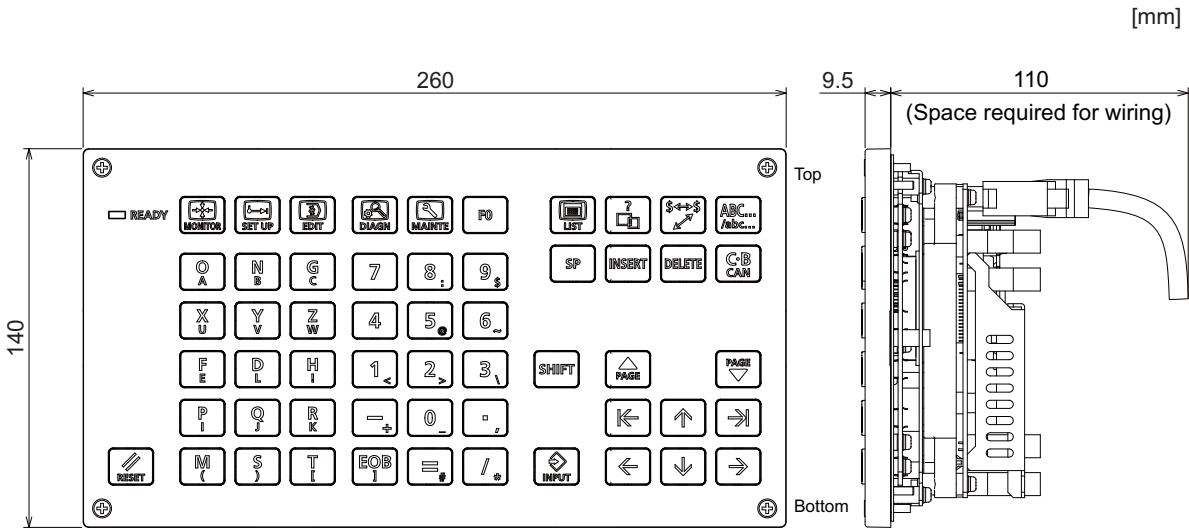

Note

(1) The above side view shows the state with the operation panel I/O unit mounted.

Panel cut dimensions

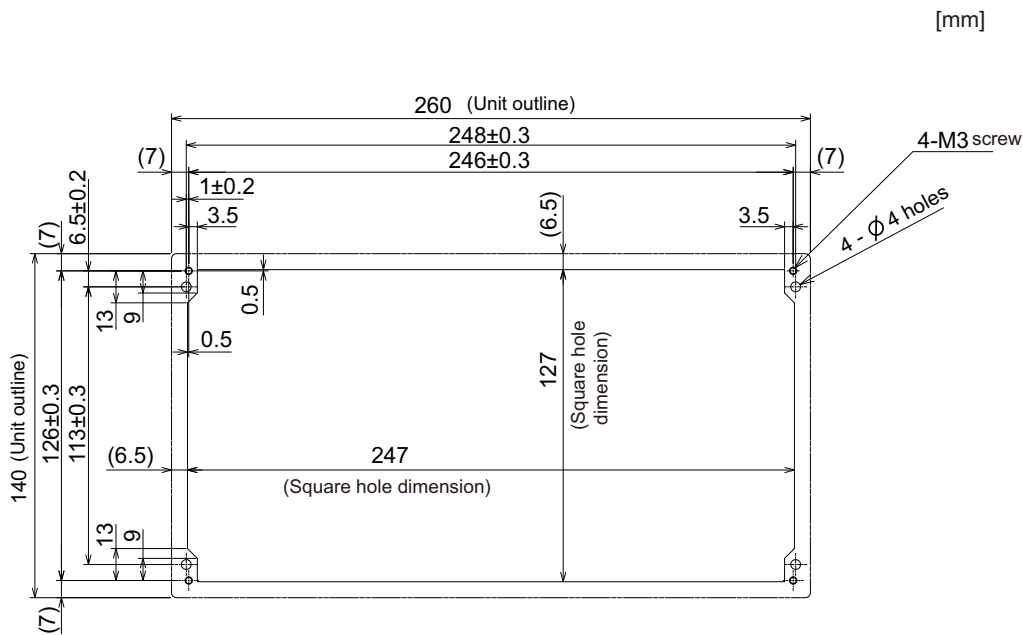

4.7.4 Keyboard for 10.4-type Display Unit (FCU8-KB041)

Outline dimensions

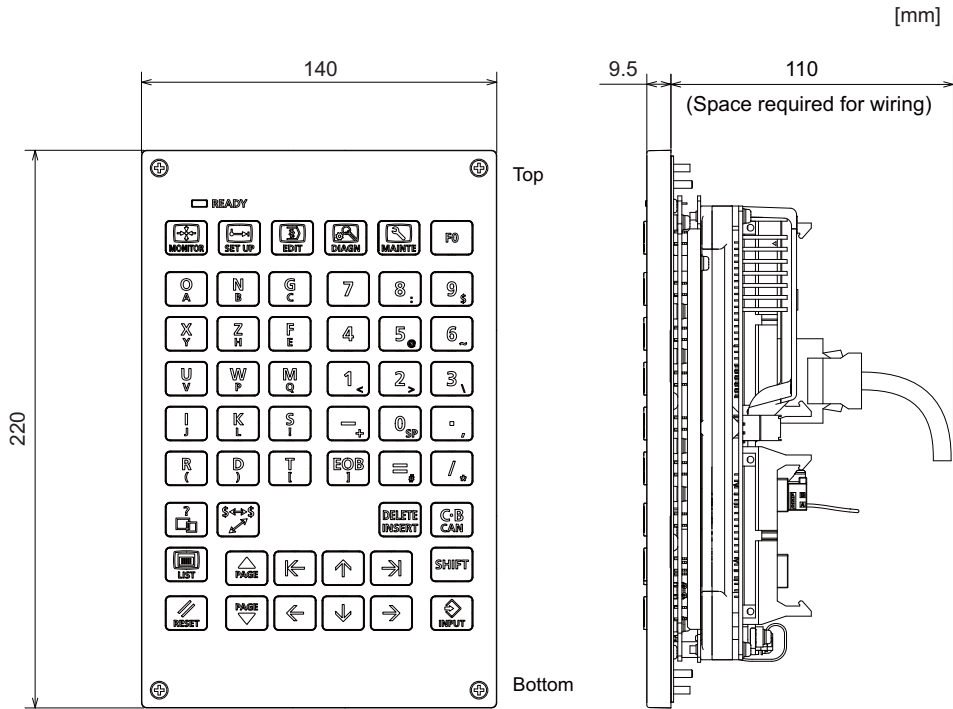

Note

(1) The above side view shows the state with the operation panel I/O unit mounted.

Panel cut dimensions

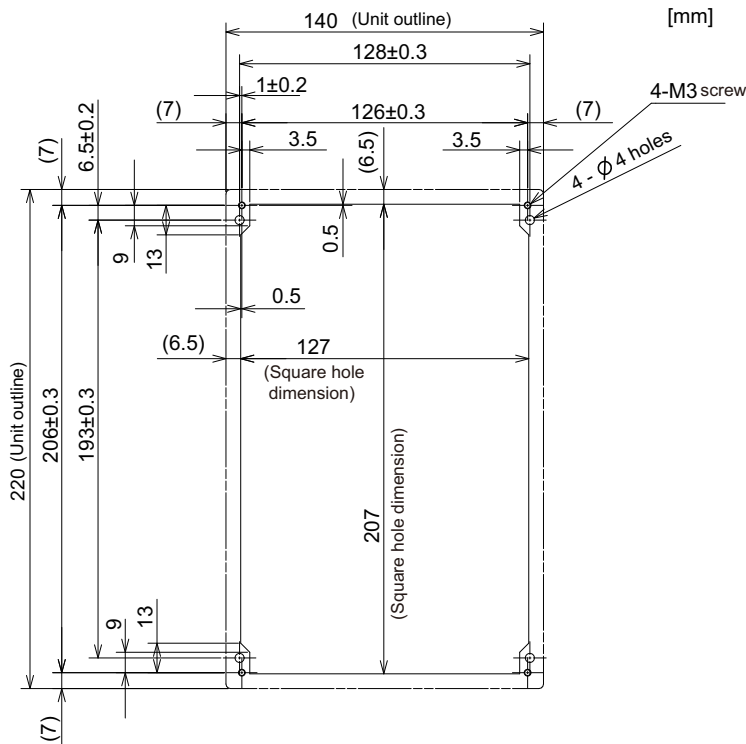

4.7.5 Keyboard for 10.4-type Display Unit (FCU8-KB046)

Outline dimensions

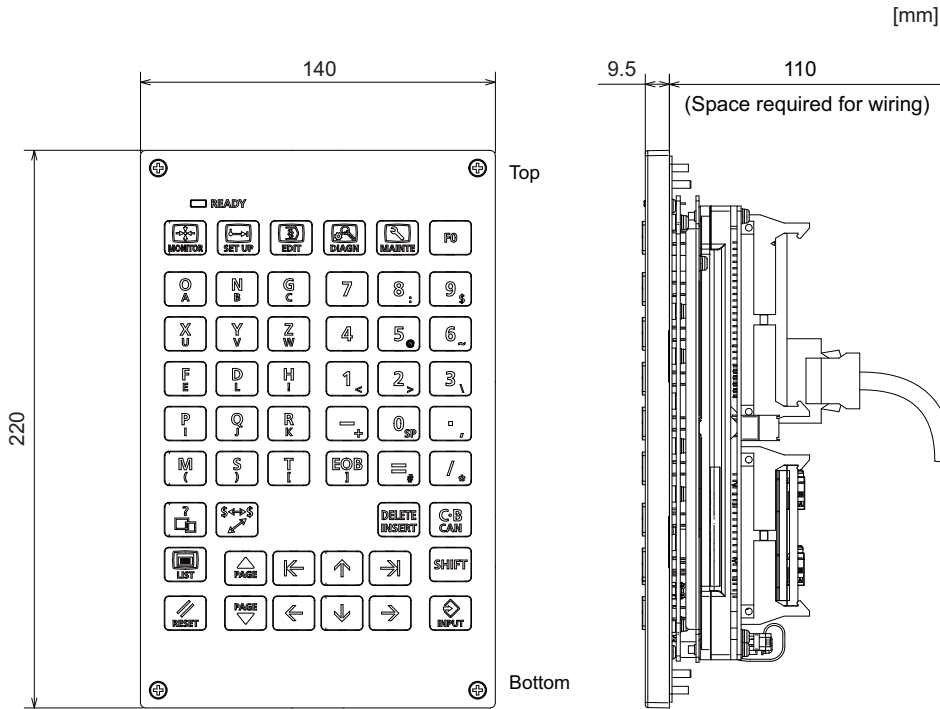

Note

(1) The above side view shows the state with the operation panel I/O unit mounted.

Panel cut dimensions

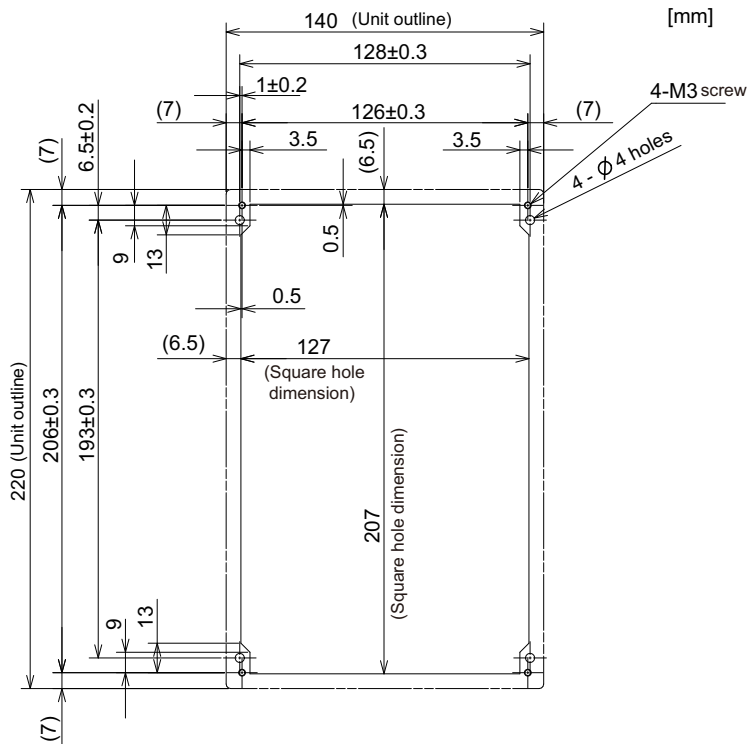

4.7.6 Keyboard for 10.4-type Display Unit (FCU8-KB047)

Outline dimensions

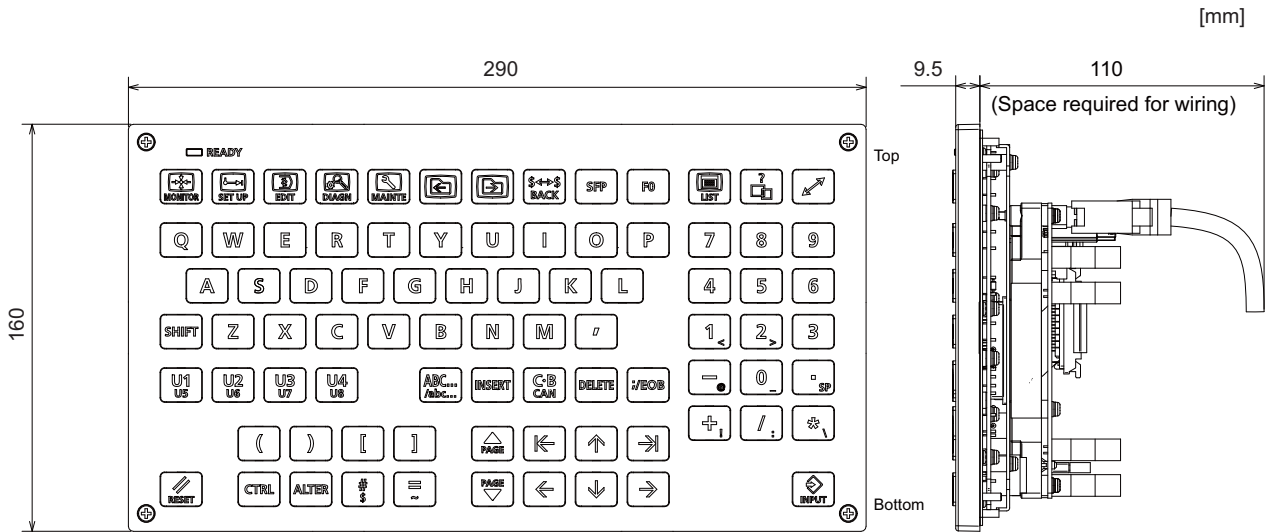

Note

- (1) The above side view shows the state with the operation panel I/O unit mounted.

Panel cut dimensions

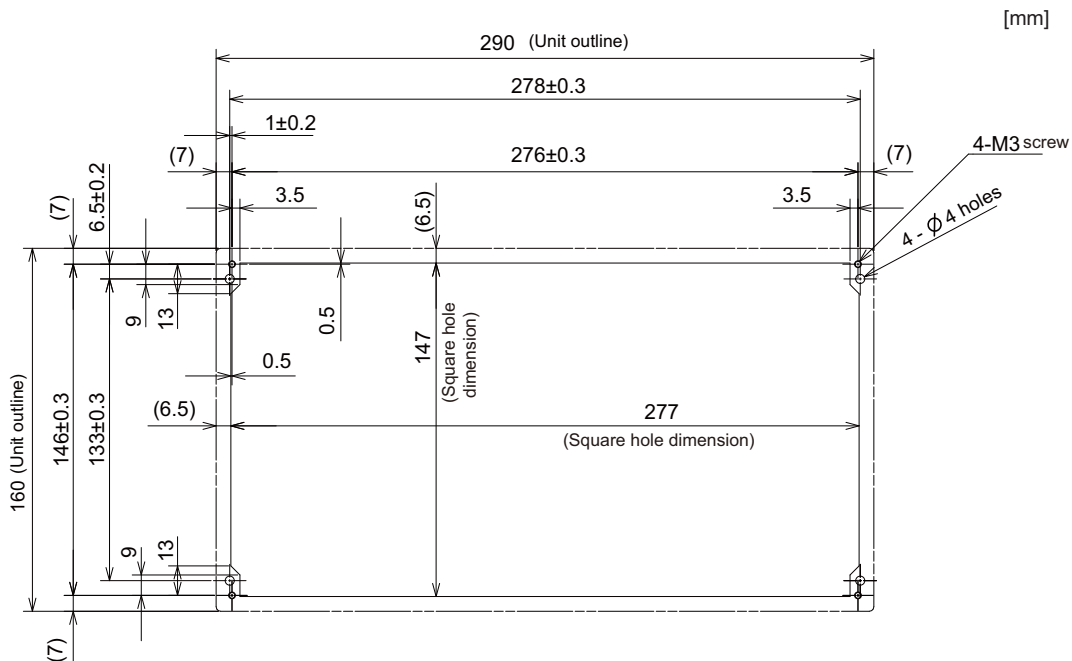

4.7.8 Keyboard for 15-type Display Unit (FCU8-KB083)

Outline dimensions

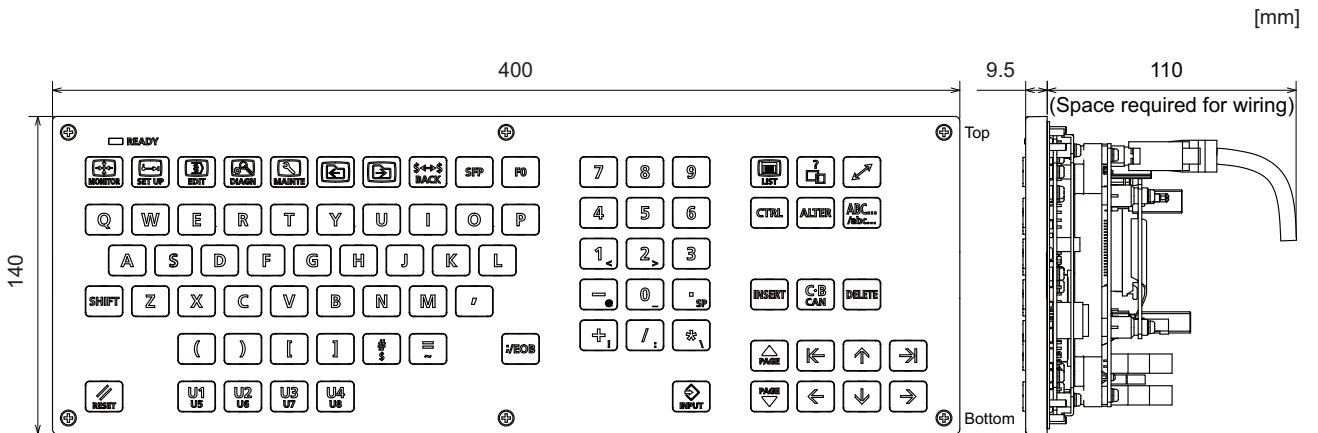

Note

(1) The above side view shows the state with the operation panel I/O unit mounted.

Panel cut dimensions

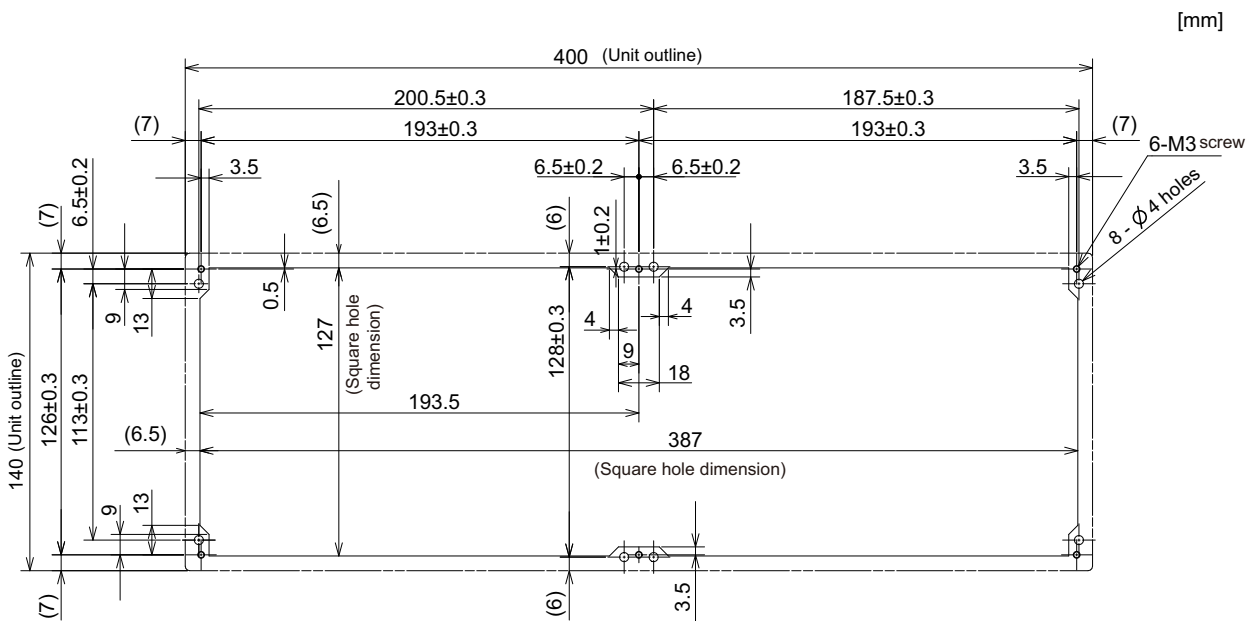

4.7.9 Keyboard for 19-type Display Unit (FCU8-KB091)

Outline dimensions

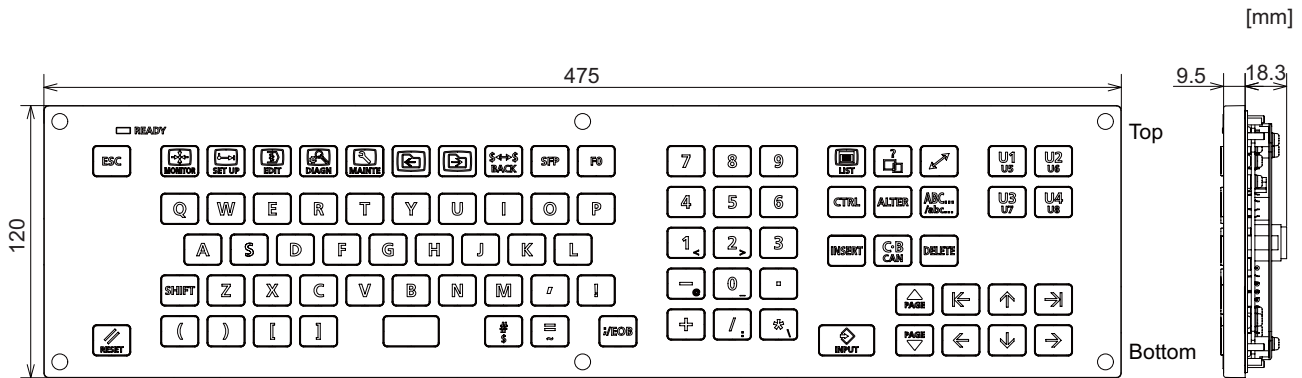

Note

(1) The above side view shows the state with the operation panel I/O unit mounted.

Panel cut dimensions

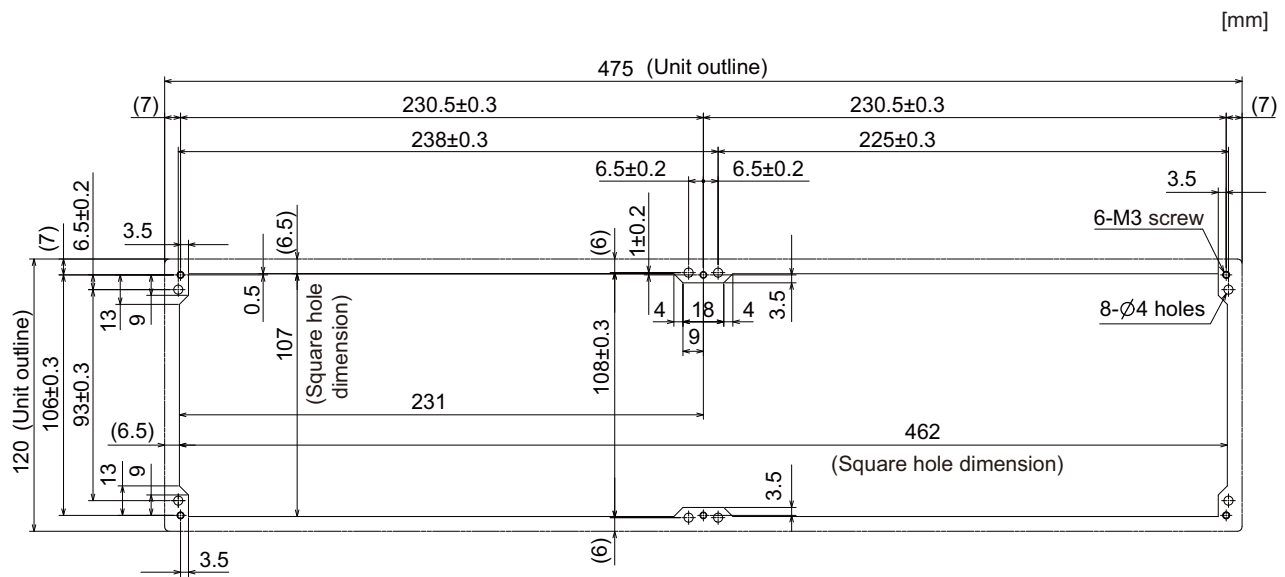

4.8 Operation Panel I/O Unit

4.8.1 List of Units

Classification	Type	Components	Remarks
DI 24 V/0 V common input [64 points] DO Source output [48 points] AO analog output [1 point]	FCU8-DX731 (*1)	Base card RIO 2.0 terminator connector (R2-TM)	DI: 64-point 24 V/0 V common type DO: 48-point source type (200 mA/point) AO: 1 point Manual pulse generator input: 2 ch Control unit I/F Keyboard unit I/F Remote I/O 2.0 I/F RIO occupied stations (fixed): 1, 3, 7 to 12, 20 to 22 RIO extensible stations: 2, 4 to 6, 13 to 19, 23 to 64
DI 24 V/0 V common input [96 points] DO Source output [64 points]	FCU8-DX750	Base card RIO 2.0 terminator connector (R2-TM)	DI: 96-point 24 V/0 V common type DO: 64-point source type (200 mA/point) Manual pulse generator input: 3 ch Control unit I/F Keyboard unit I/F Remote I/O 2.0 I/F RIO occupied stations (fixed): 1 to 3, 7 to 12, 20 to 22 RIO extensible stations: 4 to 6, 13 to 19, 23 to 64
DI 24 V/0 V common input [96 points] DO Source output [96 points]	FCU8-DX760	Base card Add-on card RIO 2.0 terminator connector (R2-TM)	DI: 96-point 24 V/0 V common type DO: 96-point source type (200 mA/point) Manual pulse generator input: 3 ch Control unit I/F Keyboard unit I/F Remote I/O 2.0 I/F RIO occupied stations (fixed): 1 to 4, 7 to 12, 20 to 22 RIO extensible stations: 5, 6, 13 to 19, 23 to 64
DI 24 V/0 V common input [96 points] DO Source output [64 points] AI Analog input [1 point] AO Analog output [1 point]	FCU8-DX761	Base card Add-on card RIO 2.0 terminator connector (R2-TM)	DI: 96-point 24 V/0 V common type DO: 64-point source type (200 mA/point) AI: 1 point AO: 1 point Manual pulse generator input: 3 ch Control unit I/F Keyboard unit I/F Remote I/O 2.0 I/F RIO occupied stations (fixed): 1 to 5, 7 to 12, 20 to 22 RIO extensible stations: 6, 13 to 19, 23 to 64
DI 24 V/0 V common input [64 points] DO Source output [64 points] Scan input [64 points] Scan output [64 points]	FCU8-DX834 (*2)	Base card Add-on card RIO 2.0 terminator connector (R2-TM)	DI: 64-point 24 V/0 V common type DO: 64-point source type (200 mA/point) Scan input: 64 points Scan output: 64 points Manual pulse generator input: 3 ch Keyboard unit I/F Remote I/O 2.0 I/F RIO occupied stations (fixed): 1 to 4, 7 to 14, 20 to 22 RIO extensible stations: 5, 6, 15 to 19, 23 to 64

(*1) The form of the CG31/CG32/CG35/CG36 connectors on FCU8-DX731 are the same as that of CJ38/CJ40/CJ42 connectors on other units. Be careful not to connect to a wrong connector. See the descriptions mentioned in the later section for more specific explanation on connections.

(*2) The connection method of DO (CG32/CG34) of FCU8-DX834 is different from other operation panel I/O units. Be careful not to connect to a wrong connector. See the descriptions mentioned in the later section for more specific explanation on connections.

4.8.2 FCU8-DX731/FCU8-DX750/FCU8-DX760/FCU8-DX761/FCU8-DX834

Outline dimensions: FCU8-DX731

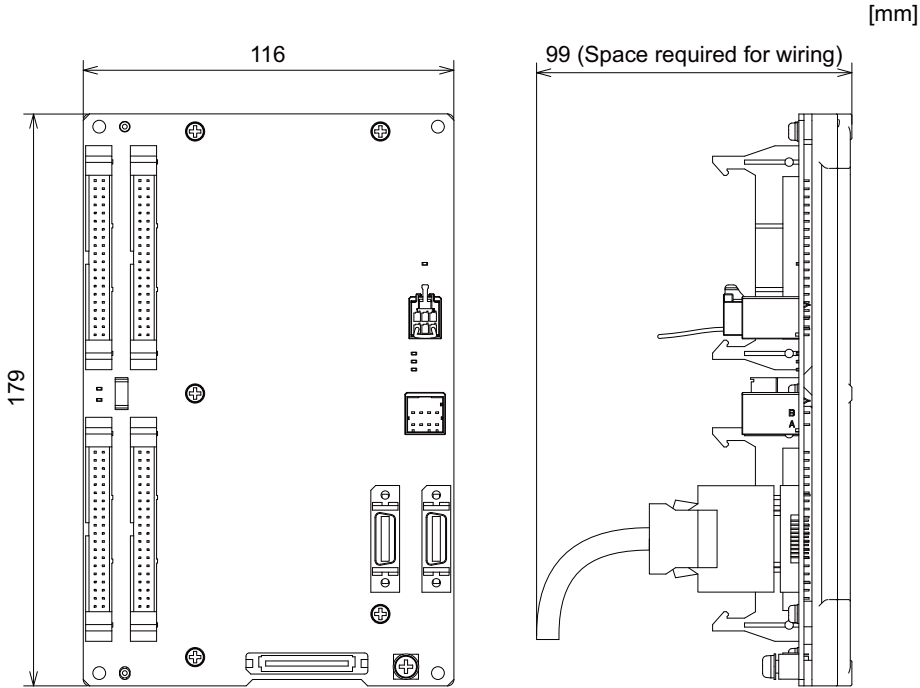

Outline dimensions: FCU8-DX750

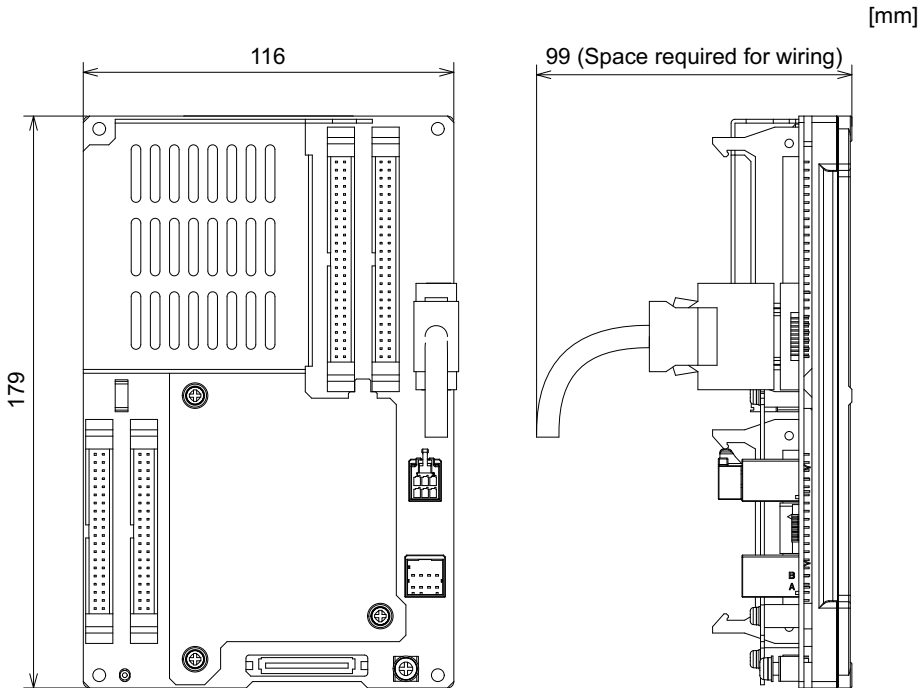

Outline dimensions: FCU8-DX760

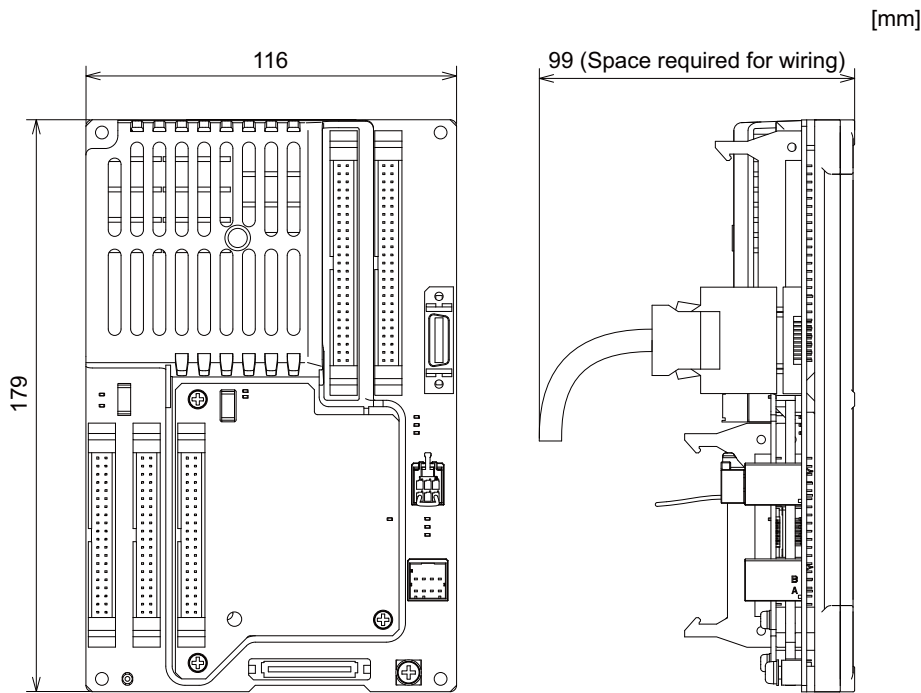

Outline dimensions: FCU8-DX761

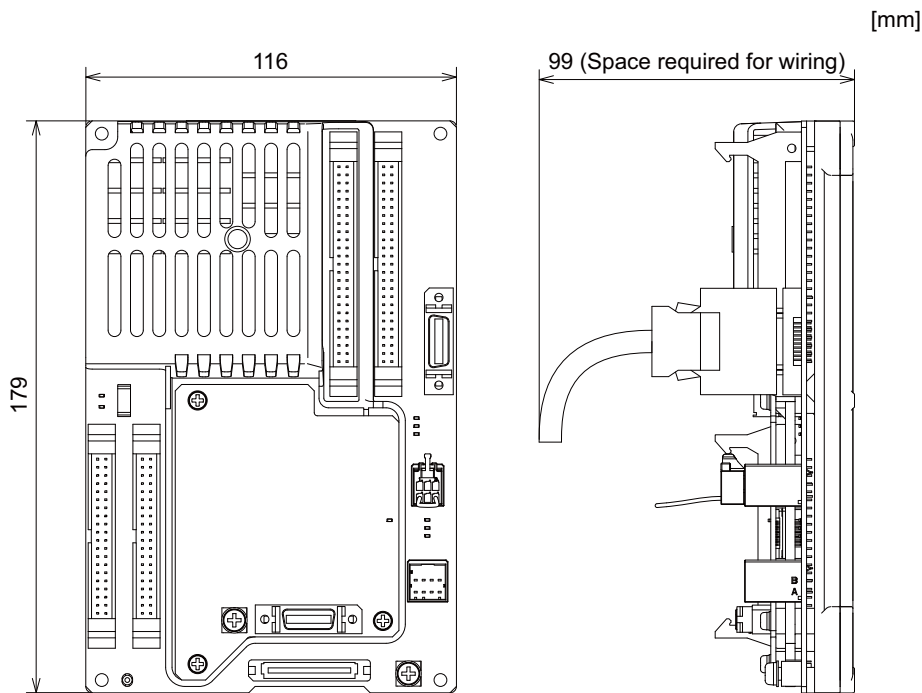

Outline dimensions: FCU8-DX834

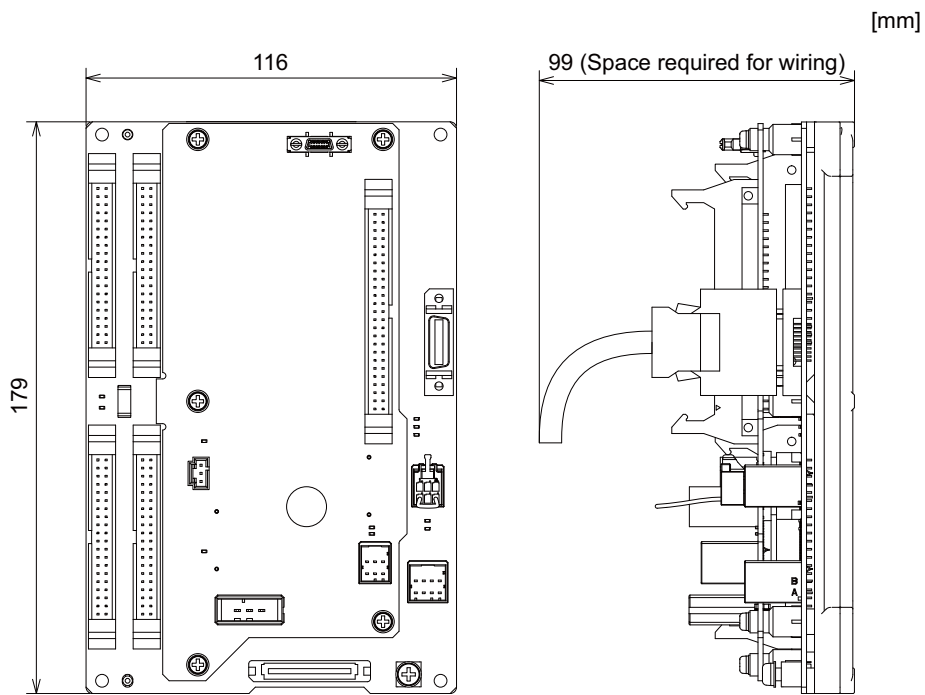

Installation dimension: FCU8-DX731/FCU8-DX750/FCU8-DX760/FCU8-DX761/FCU8-DX834

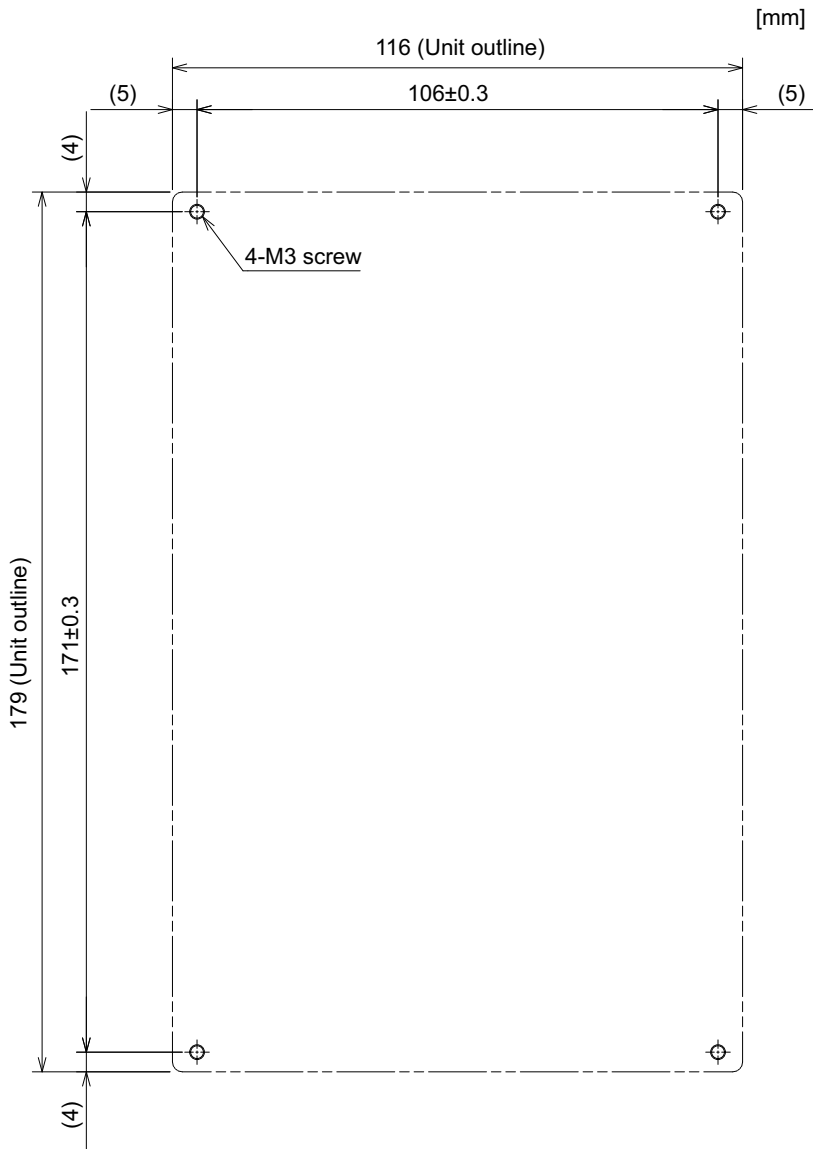

Note

- The unit thickness of the fixed part with screws is 16.6 mm.
Select the fixing screws having the length suitable for the thickness.

4.9 Remote I/O Unit

Types of signals described on the list of units can be input/output from the remote I/O unit (FCU8-DXxxx) according to the type and No. of contacts. Remote I/O units are used by being connected to the control unit or the operation panel I/O unit. Multiple remote I/O units can be used as long as the total number of occupied stations is 64 or less.

Note

(1) The maximum connectable number of remote I/O units is 32.

4.9.1 List of Units

Classification	Type	Components	Remarks
DI 24 V/0 V common input [32 points] DO Source output [32 points]	FCU8-DX220	Base card RIO 2.0 connector set	DI: 32-point 24 V/0 V common type DO: 32-point source type (200 mA/point) Number of occupied stations: 1
DI 24 V/0 V common input [64 points] DO Source output [48 points]	FCU8-DX230	Base card RIO 2.0 connector set	DI: 64-point 24 V/0 V common type DO: 48-point source type (200 mA/point) Number of occupied stations: 2
DI 24 V/0 V common input [64 points] DO Source output [48 points] AO analog output [1 point]	FCU8-DX231	Base card RIO 2.0 connector set	DI: 64-point 24 V/0 V common type DO Source type [48 points] (200 mA/point) AO: 1 point Number of occupied stations: 2
AI analog input [4 points] AO analog output [1 point]	FCU8-DX202	Base card RIO 2.0 connector set	AI: 4 points AO: 1 point Number of occupied stations: 1
DI 0 V common input [16 points] DO Source output (large capacity) [8 points]	FCU8-DX213	Base card RIO 2.0 connector set	DI: 16-point 0 V common type (3 mA/point) DO: 8-point source type (2 A/point) Number of occupied stations: 1
DI 0 V common input [16 points] DO Source output (large capacity) [8 points]	FCU8-DX213-1	Base card RIO 2.0 connector set	DI: 16-point 0 V common type (9 mA/point) DO: 8-point source type (2 A/point) Number of occupied stations: 1
Safety DI 0 V common input [8 points] Safety DO Source output (large capacity) [4 points]	FCU8-DX654	Base card RIO 2.0 connector set	Safety DI: 8-point 0 V common type (3 mA/point) Safety DO: 4-point source type (2 A/point) Number of occupied stations: 2
Safety DI 0 V common input [8 points] Safety DO Source output (large capacity) [4 points]	FCU8-DX654-1	Base card RIO 2.0 connector set	Safety DI: 8-point 0 V common type (9 mA/point) Safety DO: 4-point source type (2 A/point) Number of occupied stations: 2
DI 24 V/0 V common input [32 points] DO Source output [32 points] Safety DI 0V common input [8 points] (*1) Safety relay output [4 points] (*2)	FCU8-DX651	Base card Add-on card RIO 2.0 connector set	DI: 24 V/0 V common type [32 points] DO: 32-point source type (200 mA/point) Safety DI: 8-point 0 V common type Safety relay: 4 points (non-voltage contact) Relay contact welding detection Number of occupied stations: 3
Thermistor input (12 points)	FCU8-DX408	Base card RIO 2.0 connector set	Thermistor input: 12 points Number of occupied stations: 3
Multi-analog input [4 points] (*3)	FCU8-DX409	Base card RIO 2.0 connector set	Multi-analog input: 4 points Number of occupied stations: 4

(*1) Safety DI uses 16 points of terminal because of the duplication wiring.

(*2) Safety relay output uses 8 points of terminal because of the duplication wiring.

(*3) Voltage input, current input, thermocouple input and resistance temperature detector input are selected for each CH.

**4.9.2 FCU8-DX220/FCU8-DX230/FCU8-DX231/FCU8-DX202/FCU8-DX213/
FCU8-DX213-1/FCU8-DX654/FCU8-DX654-1/FCU8-DX651/FCU8-DX408/
FCU8-DX409**

Outline dimensions: FCU8-DX220

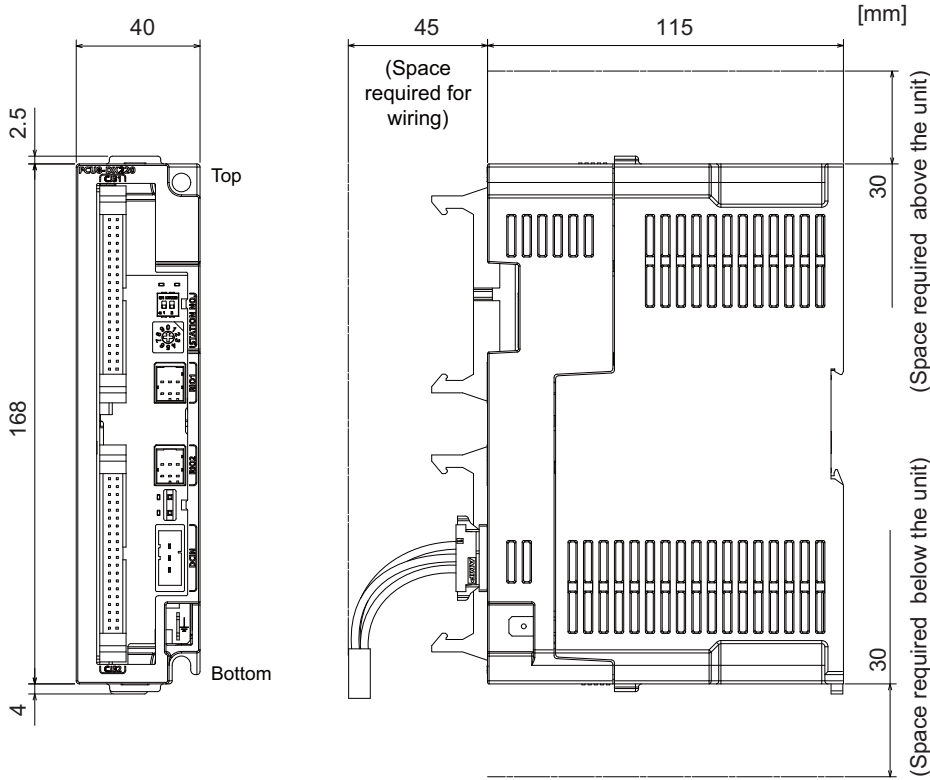

Outline dimensions: FCU8-DX230

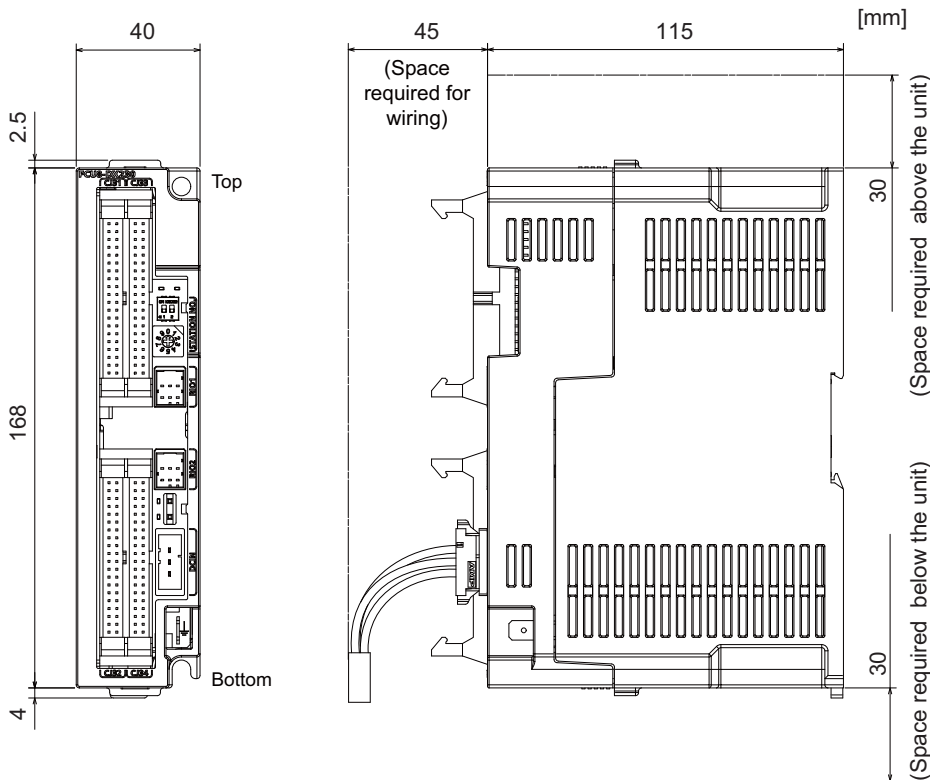

Outline dimensions: FCU8-DX231

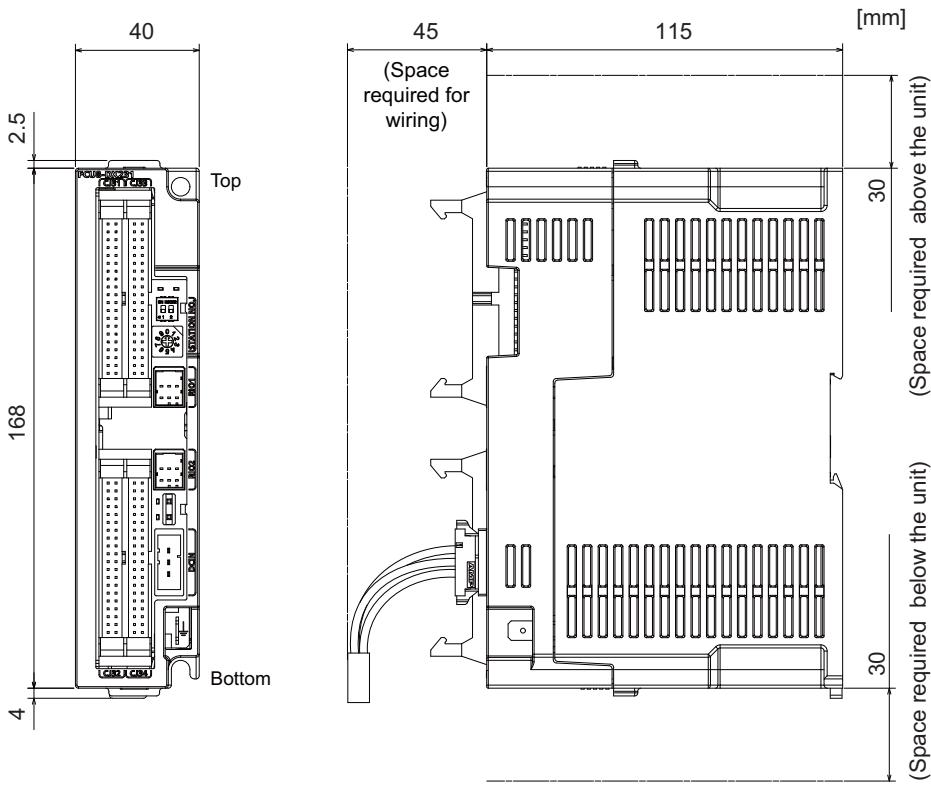

Outline dimensions: FCU8-DX202

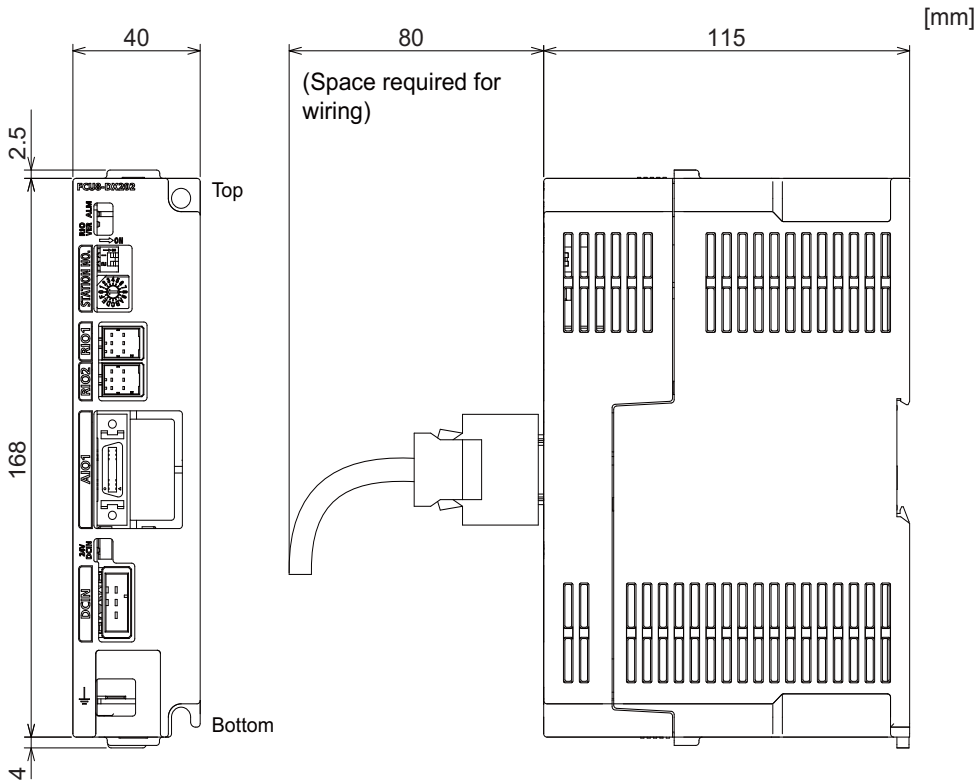

Outline dimensions: FCU8-DX213

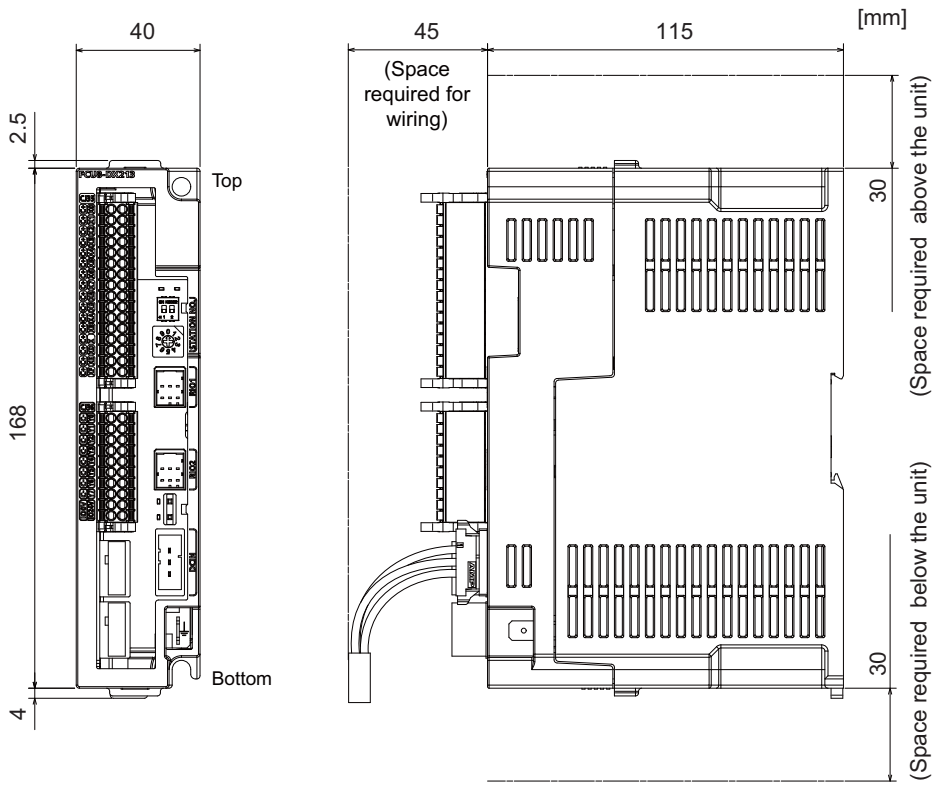

Outline dimensions: FCU8-DX213-1

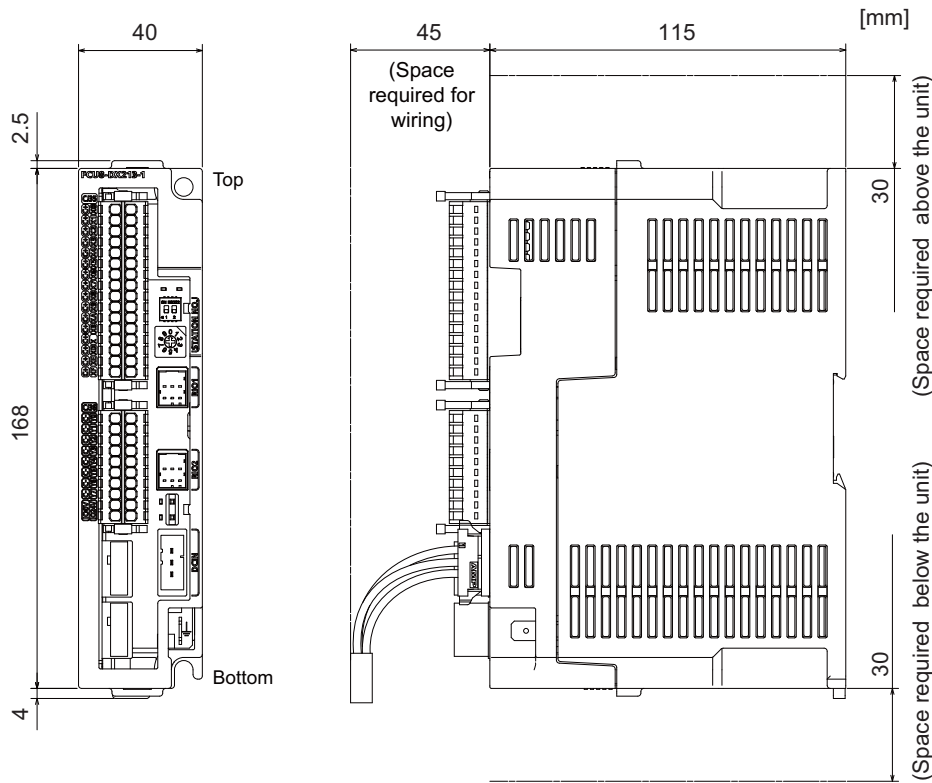

Outline dimensions: FCU8-DX654

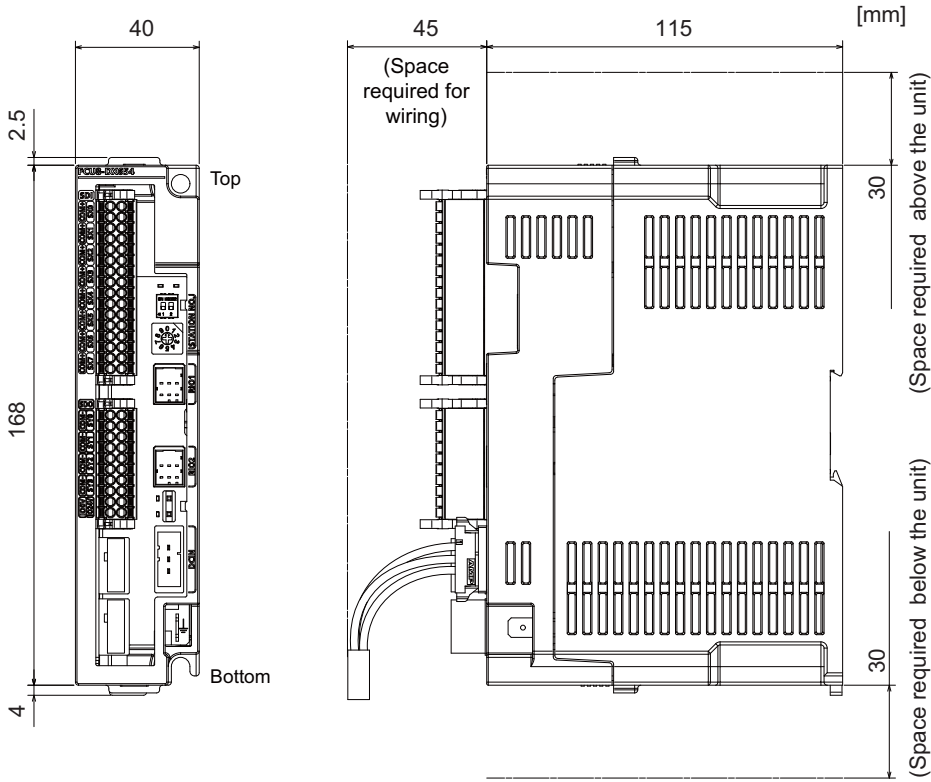

Outline dimensions: FCU8-DX654-1

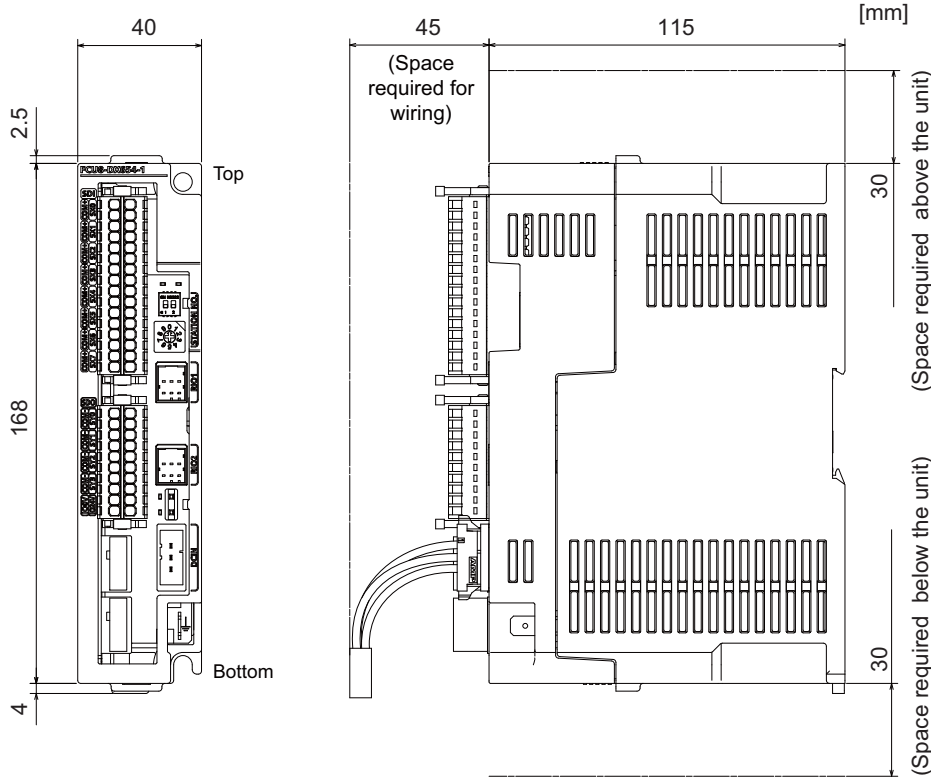

Outline dimensions: FCU8-DX651

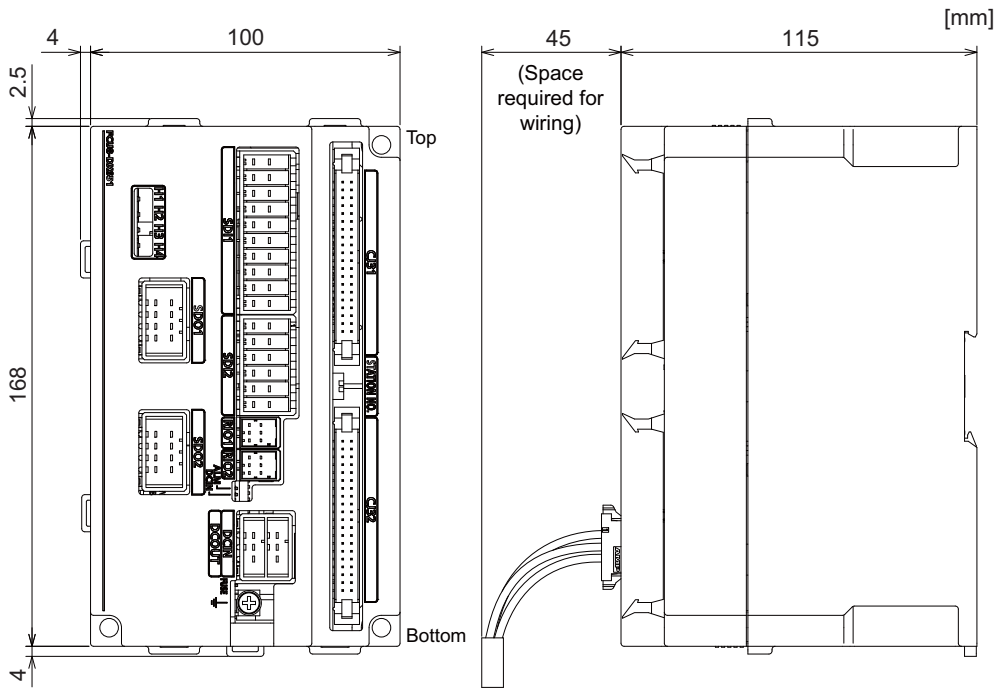

Outline dimensions: FCU8-DX408

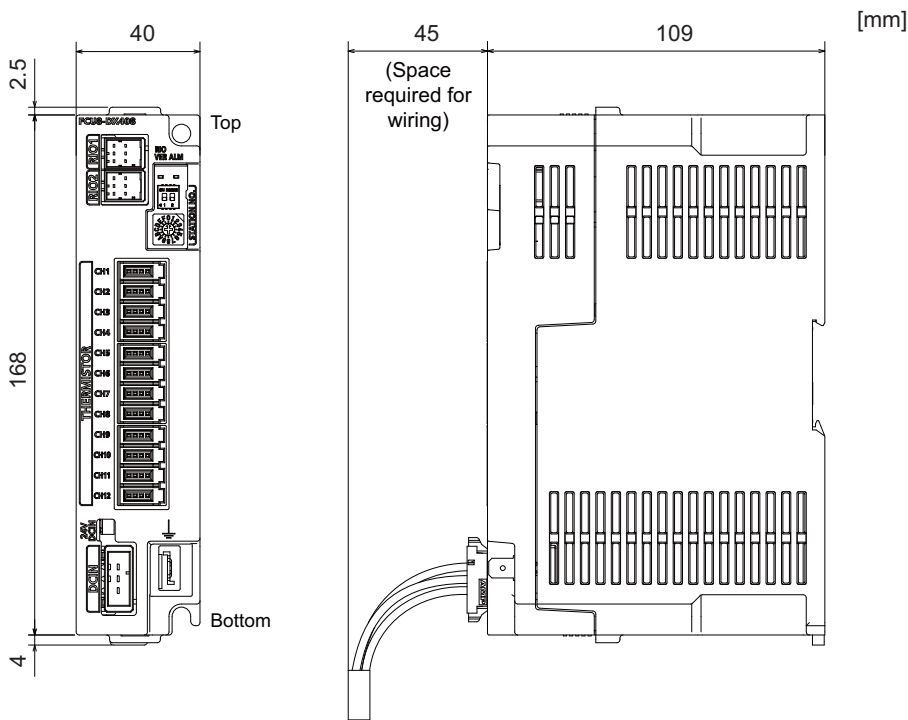

Outline dimensions: FCU8-DX409

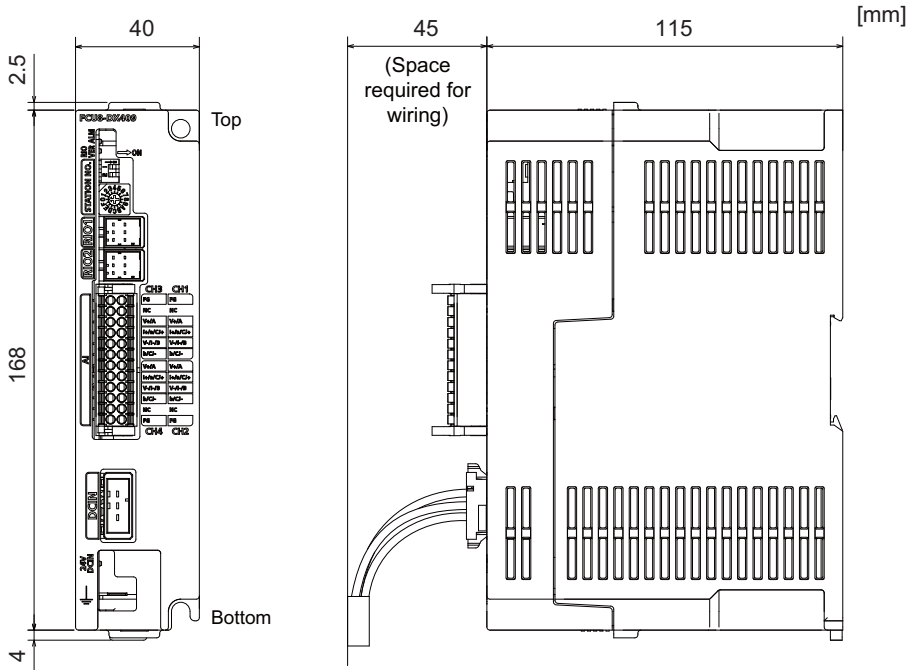

**Installation dimensions: FCU8-DX220/FCU8-DX230/FCU8-DX231/FCU8-DX202/FCU8-DX213/
FCU8-DX213-1/FCU8-DX654/FCU8-DX654-1/FCU8-DX408/FCU8-DX409**

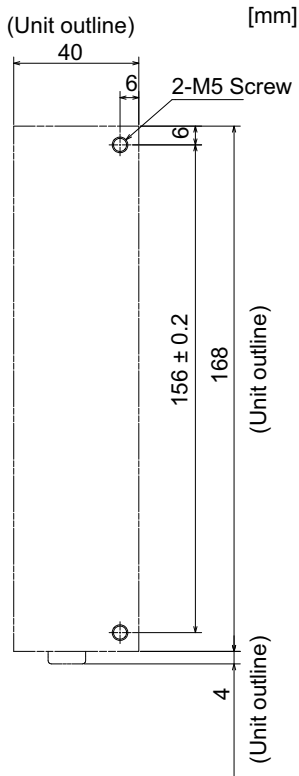

Installation dimensions: FCU8-DX651

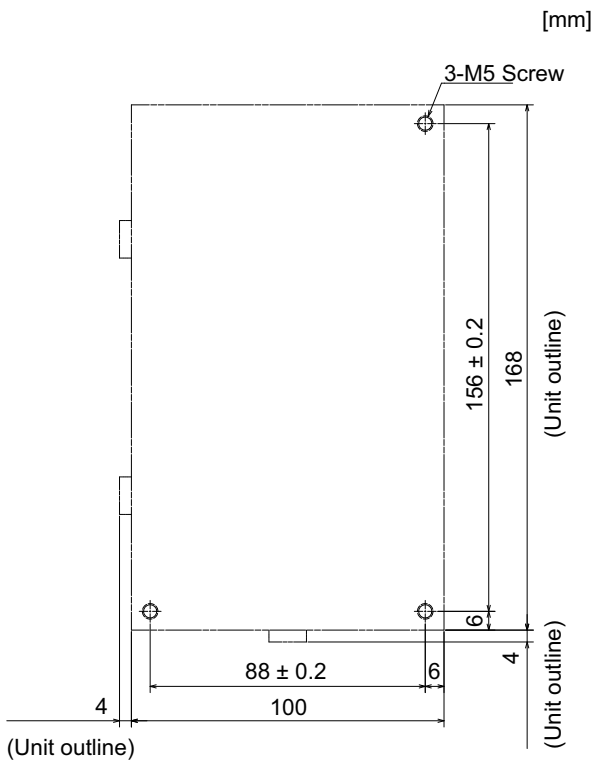

4.10 Laser I/F Unit

4.10.1 FCU8-DX522-001

Outline dimensions

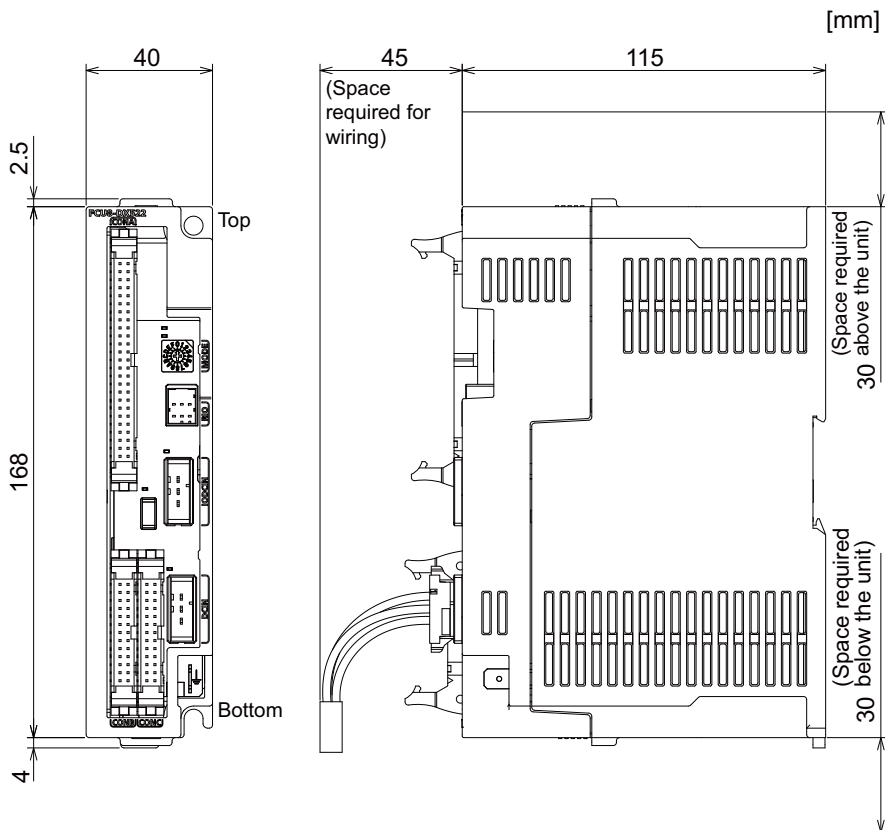

Installation dimensions

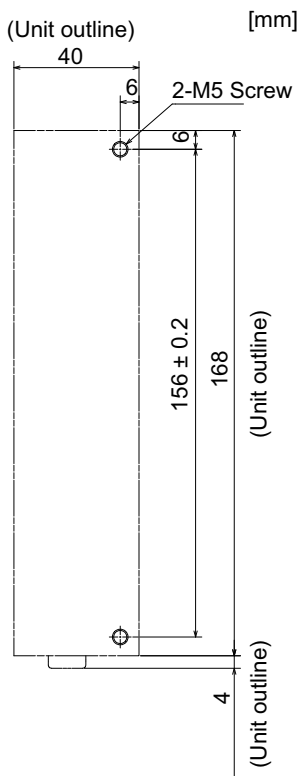

4.11 Functional Safety Expansion Unit

4.11.1 Functional Safety Expansion Unit (FCU8-EX134)

Outline dimensions

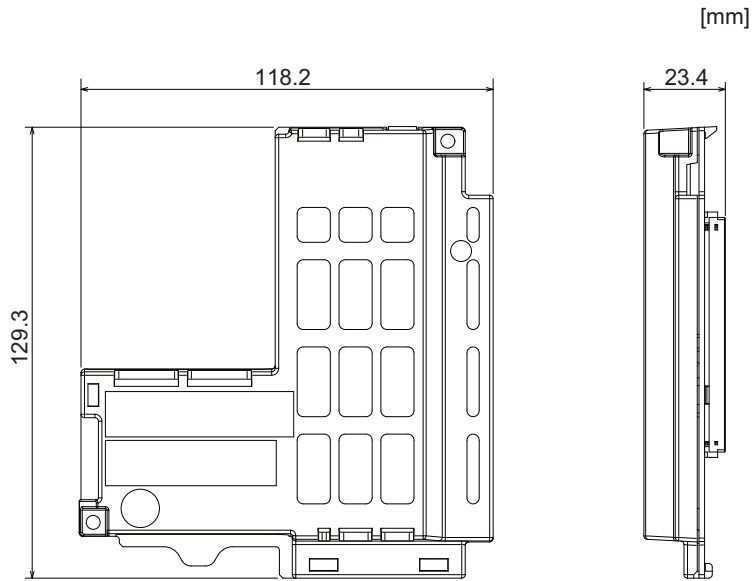

4.12 Function Expansion Unit

4.12.1 CC-Link (FCU8-EX561)

Outline dimensions

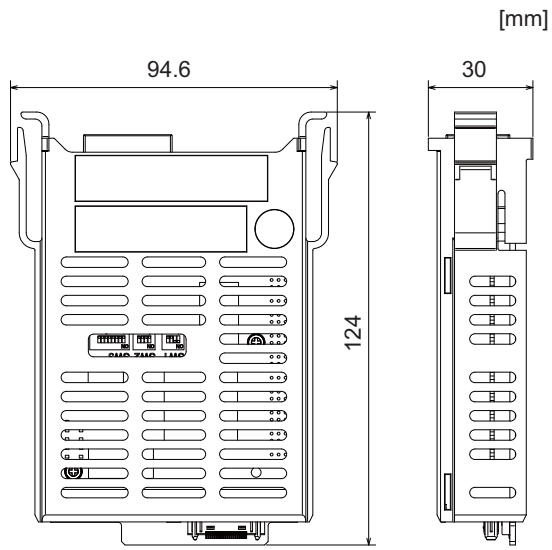

4.12.2 PROFIBUS-DP (FCU8-EX563)

Outline dimensions

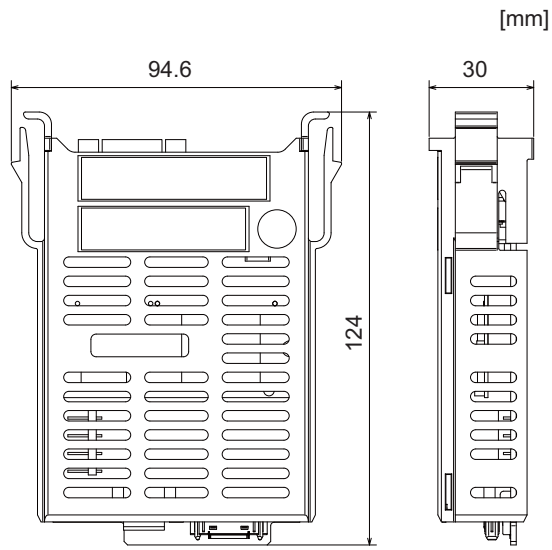

4.12.3 CC-Link IE Field (FCU8-EX564)

Outline dimensions

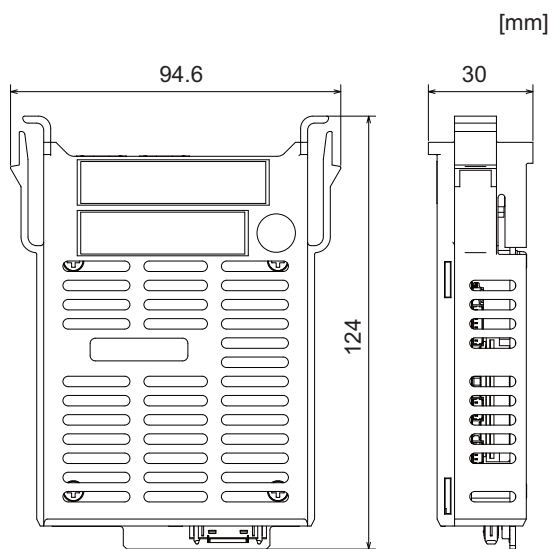

4.12.4 EtherNet/IP (FCU8-EX565)

Outline dimensions

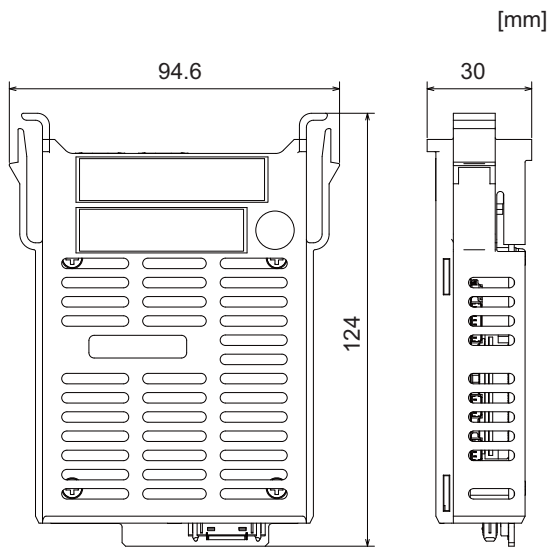

4.12.5 FL-net (FCU8-EX568)

Outline dimensions

[mm]

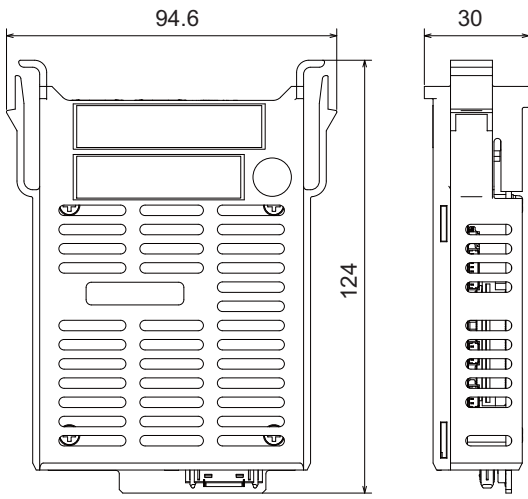

4.12.6 Vibration Cutting Expansion Unit (FCU8-EX744)

Outline dimensions

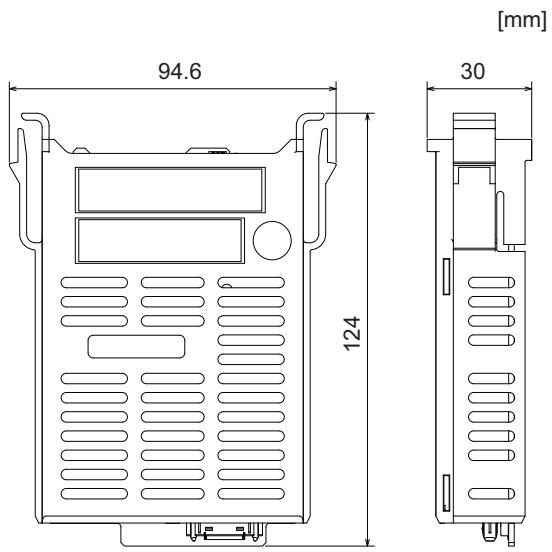

4.12.7 Image Input Expansion Unit (FCU8-EX752)

Outline dimensions

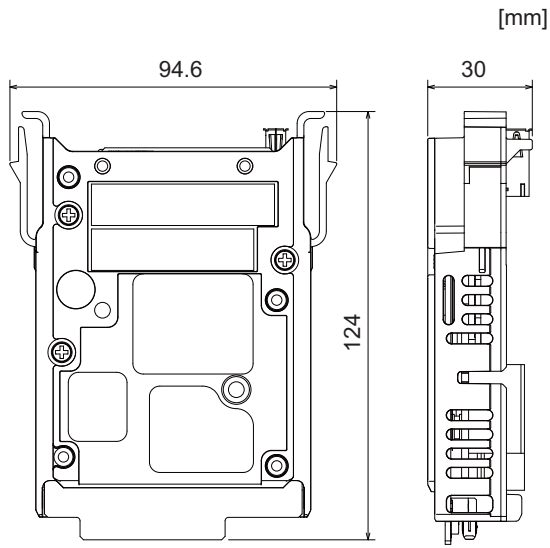

4.12.8 Option Relay Unit (FCU8-EX704)

Outline dimensions

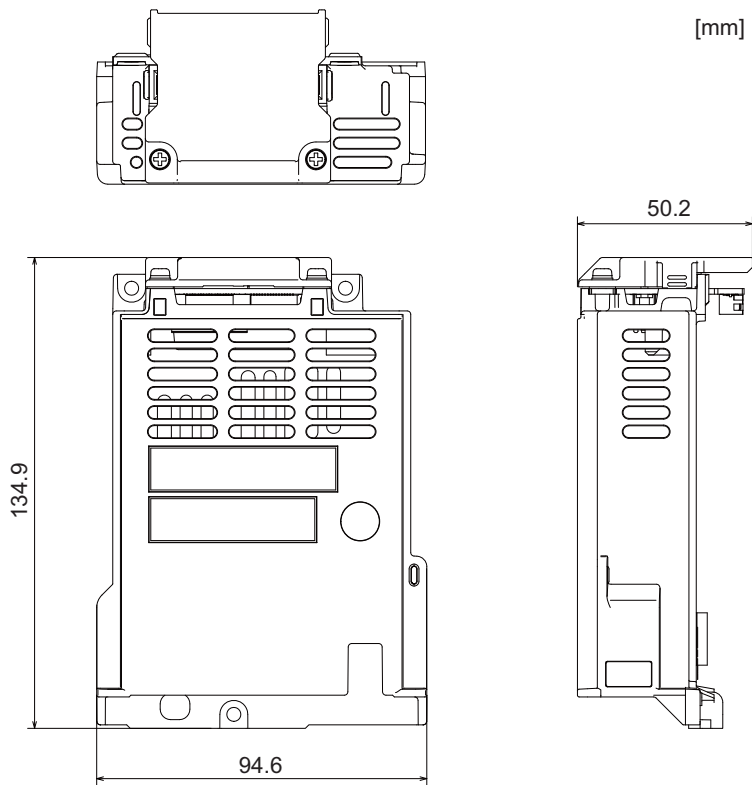

4.12.9 Option Relay Unit (FCU8-EX705)

Outline dimensions

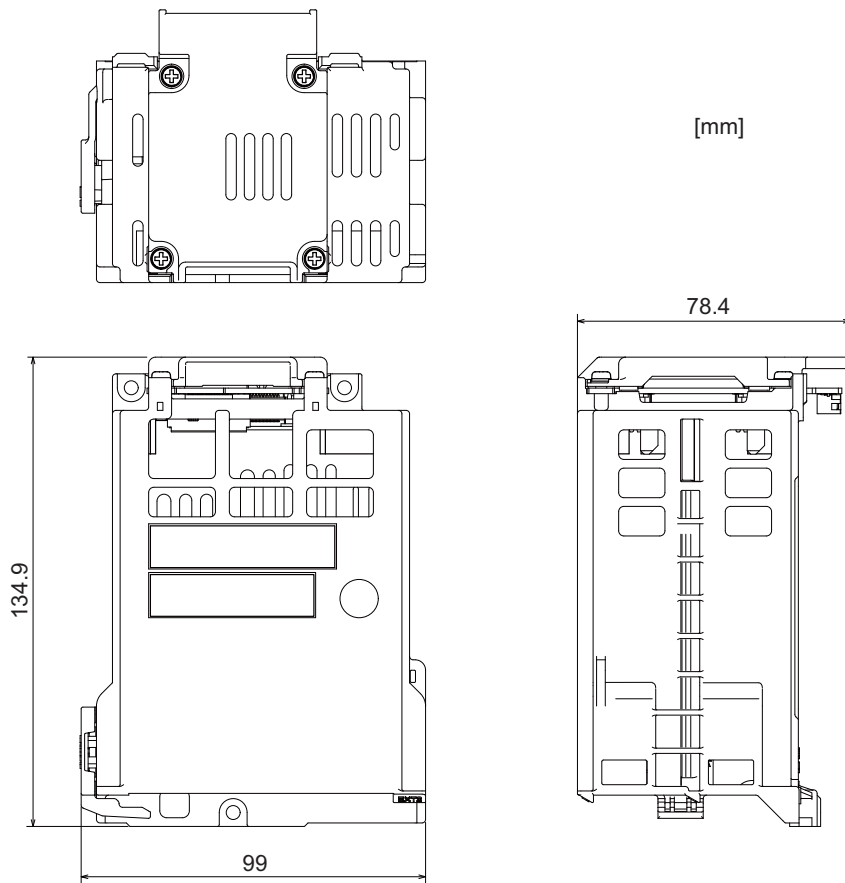

4.13.2 12 V Manual Pulse Generator (HD60C)

■ 25 pulse/rev

Outline dimensions

[mm]

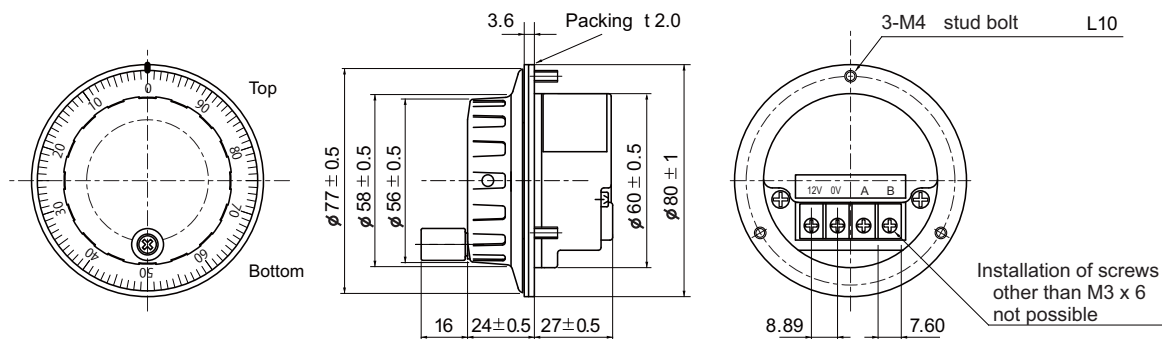

Panel cut dimensions

[mm]

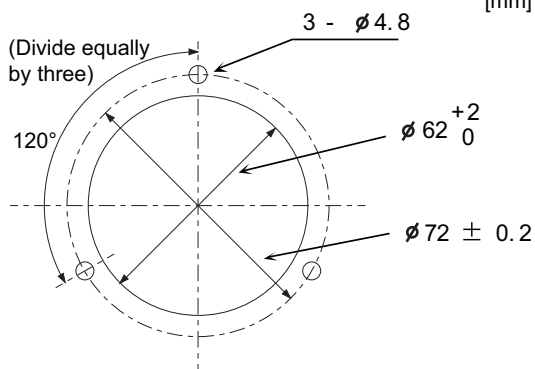

4.14 Synchronous Feed Encoder

4.14.1 Synchronous Feed Encoder (OSE-1024-3-15-68)

Outline dimensions

[mm]

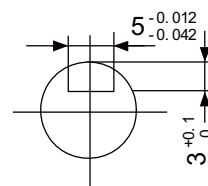
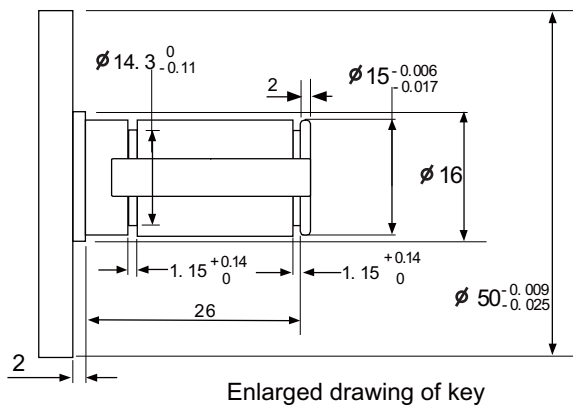
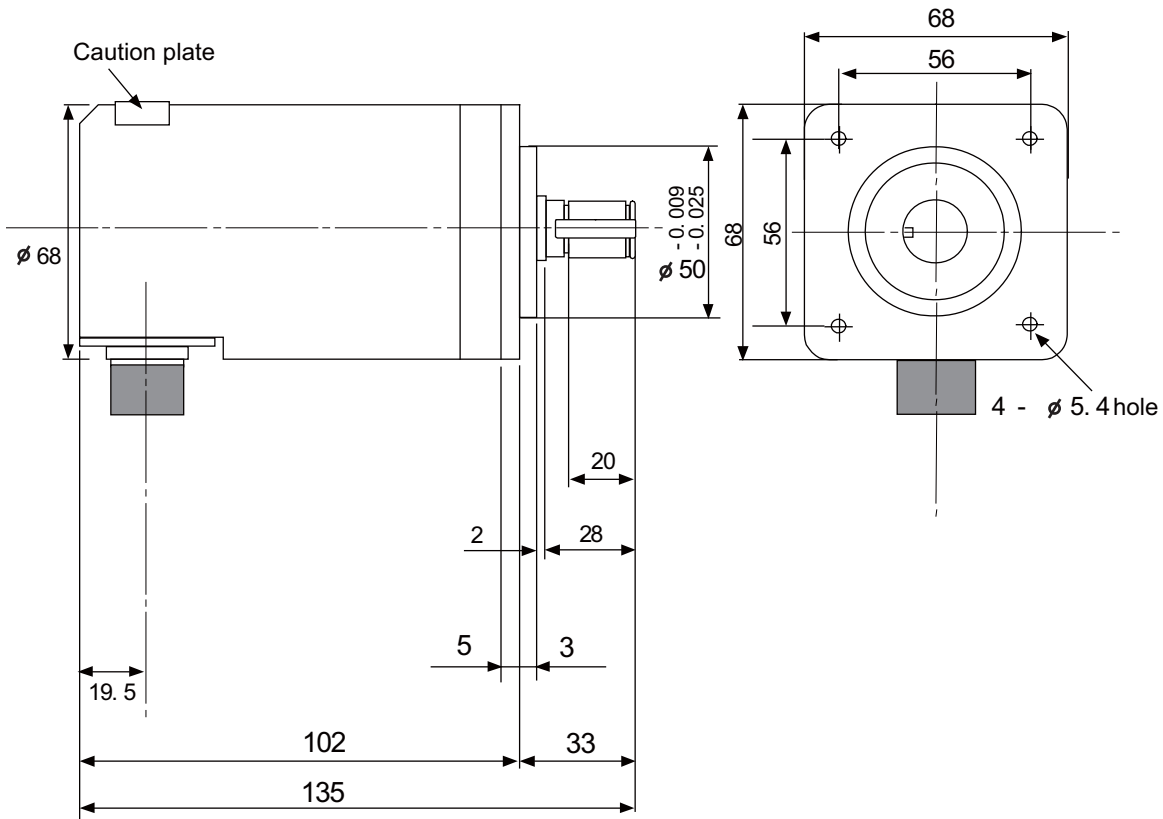

Cross section BB
Valid depth of key groove is 21mm

Connector

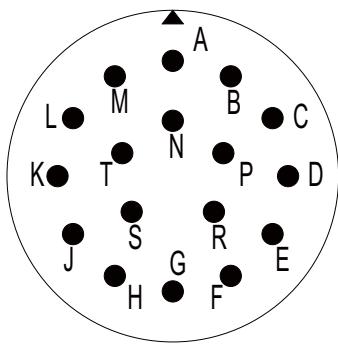

<Connector pin assignment>

Pin	Function	Pin	Function
A	A phase	K	0 V
B	Z phase	L	-
C	B phase	M	-
D	-	N	A phase reverse
E	Case grounding	P	Z phase reverse
F	-	R	B phase reverse
G	-	S	-
H	+5 V	T	-
J	-		

4.15 Machine Operation Panel

4.15.1 Main Panels A/B

(FCU8-KB921/FCU8-KB922/FCU8-KB925, FCU8-KB923/FCU8-KB924/FCU8-KB926)

Outline dimensions: FCU8-KB921

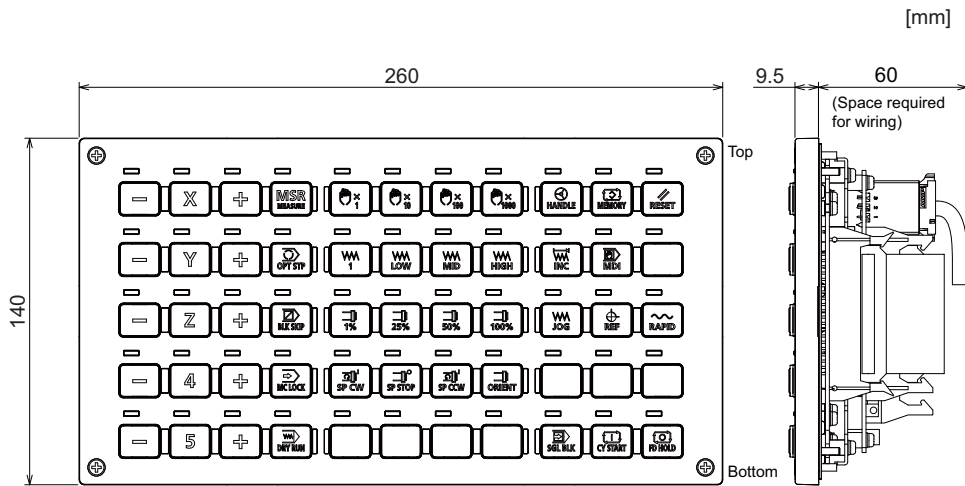

Outline dimensions: FCU8-KB922

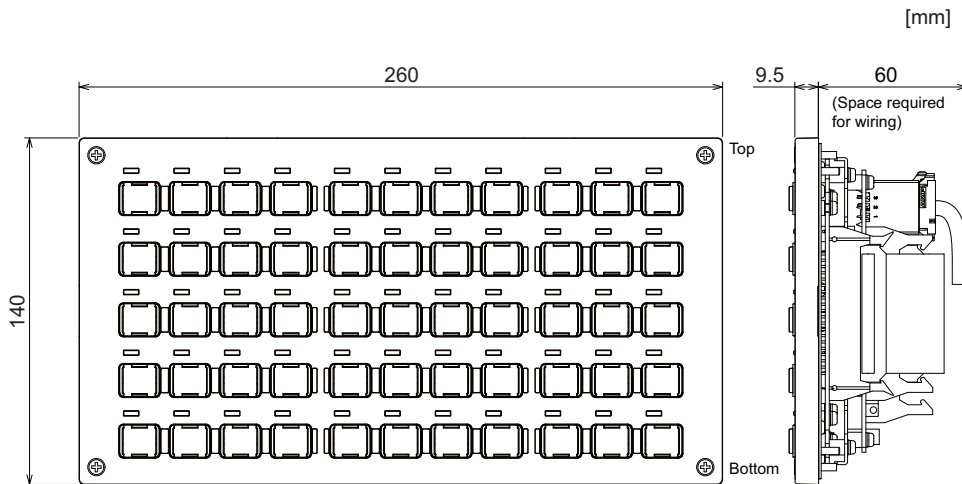

Outline dimensions: FCU8-KB925

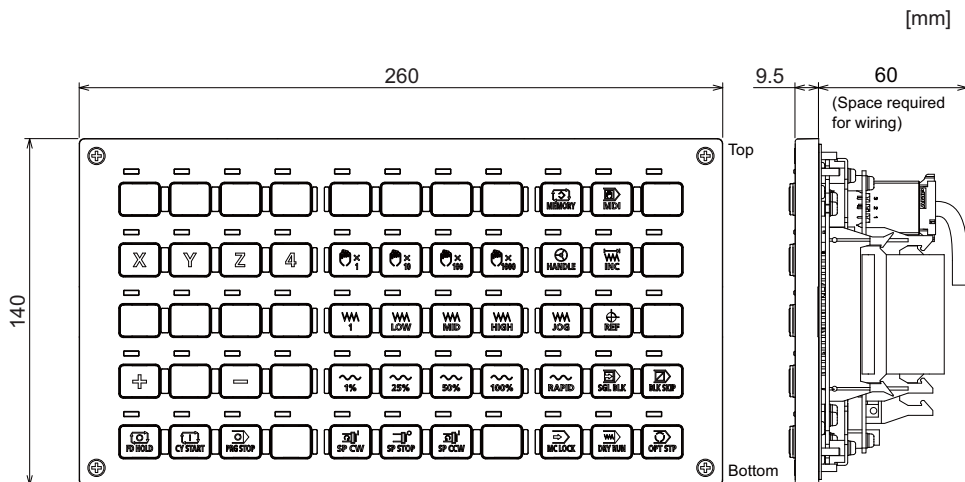

Outline dimensions: FCU8-KB923

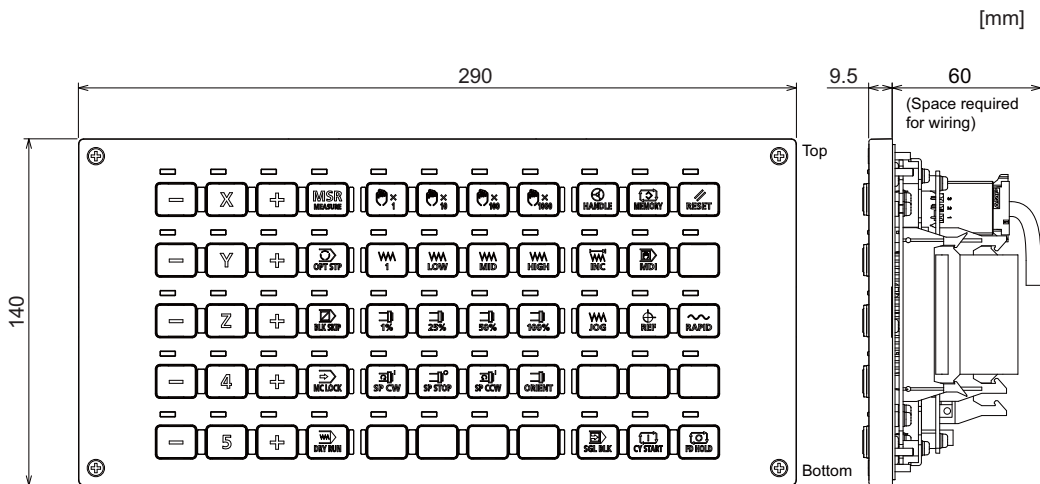

Outline dimensions: FCU8-KB924

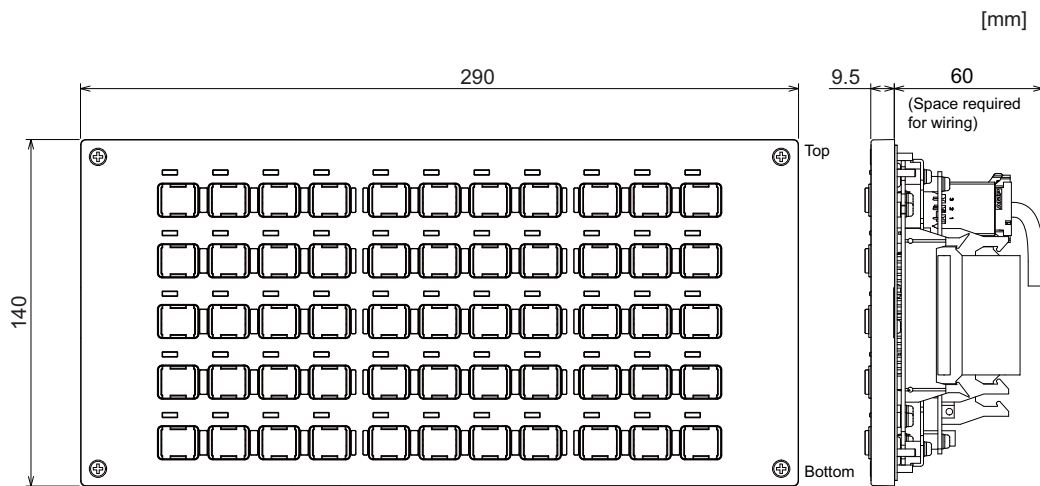

Outline dimensions: FCU8-KB926

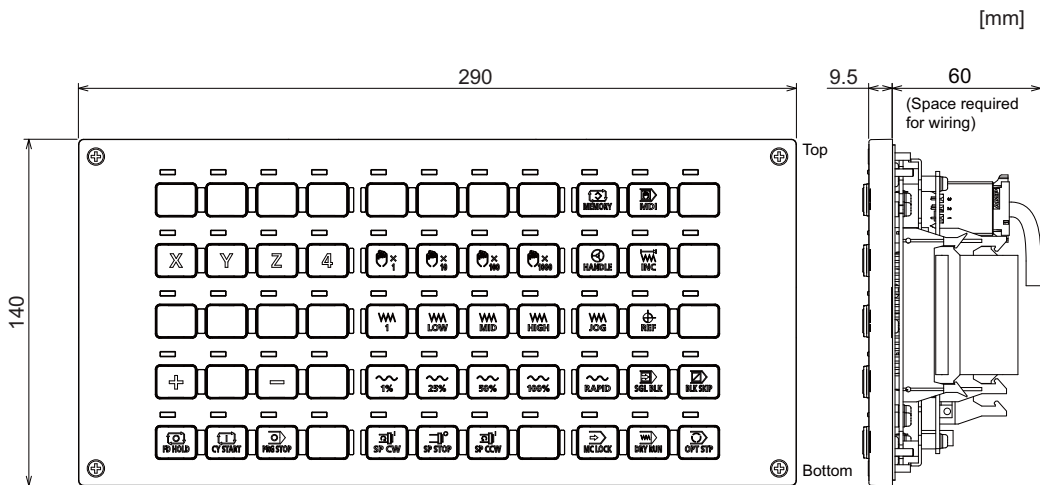

Panel cut dimensions: FCU8-KB921/FCU8-KB922/FCU8-KB925

[mm]

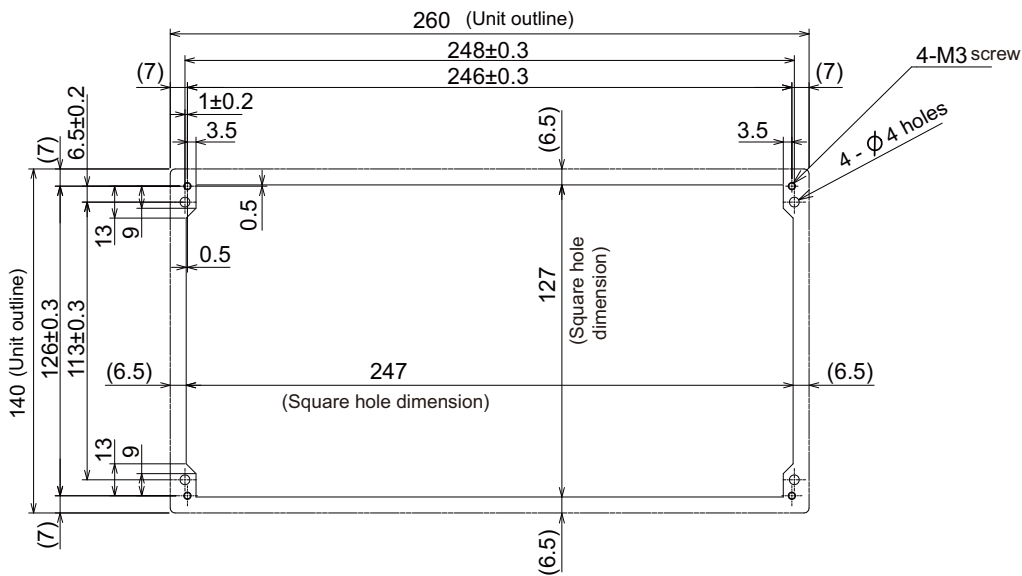

Panel cut dimensions: FCU8-KB923/FCU8-KB924/FCU8-KB926

[mm]

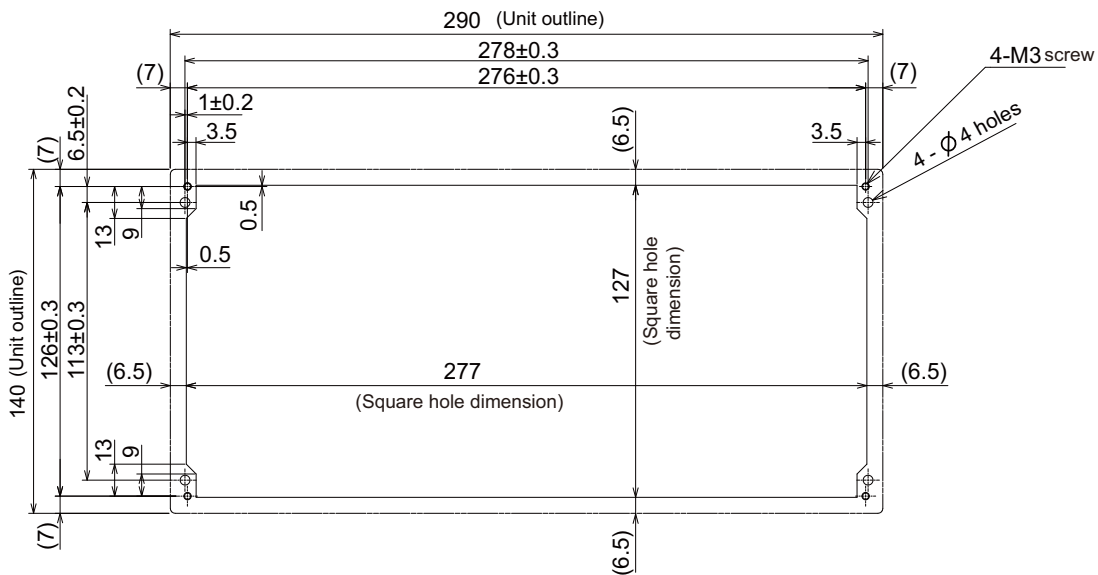

Letter label dimension: FCU8-KB922/FCU8-KB924

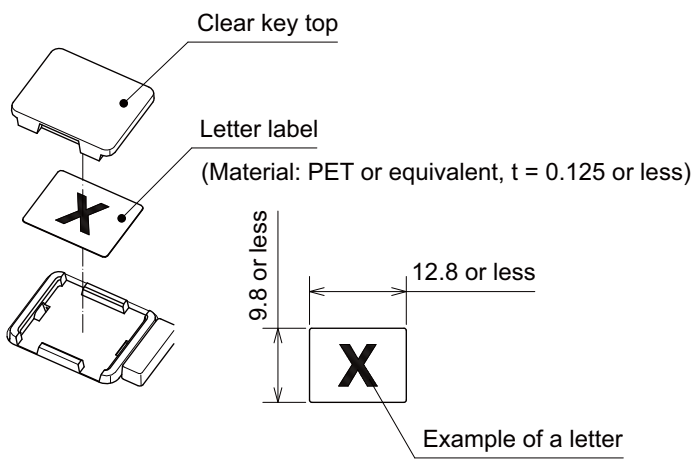

4.15.2 Sub Panel A (FCU8-KB931/FCU8-KB941)

Outline dimensions: FCU8-KB931

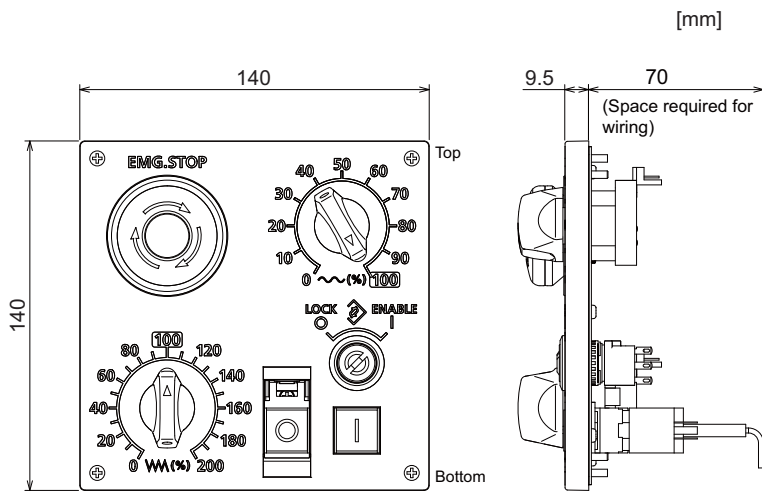

Outline dimensions: FCU8-KB941

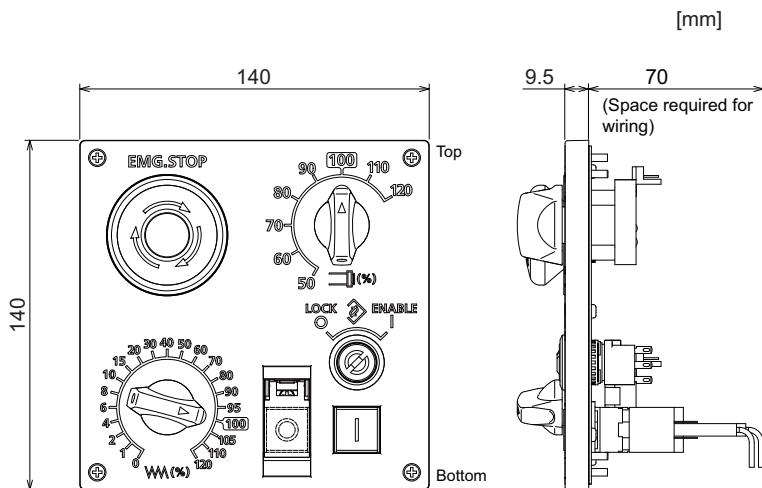

Panel cut dimensions: FCU8-KB931/FCU8-KB941

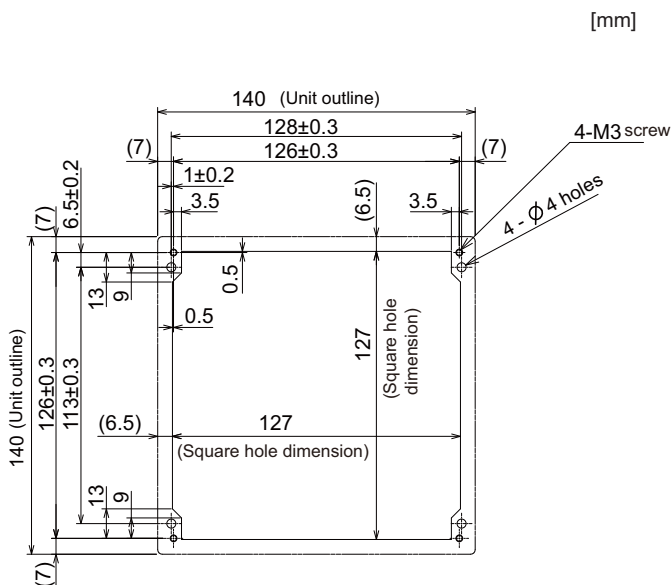

4.16 Handy Terminal

Item	Unit name		Handy terminal
	Type		HG1T-SB12UH-MK1346-L5
General specifications	Ambient temperature	During operation	0 to 40 °C
		During storage	-20 °C to 60 °C
	Ambient humidity		Long term: 10 to 75% RH (with no dew condensation)
			Short term: 10 to 95% RH (with no dew condensation) (*1)
	Vibration resistance	During operation	9.8 m/s ² [1.0 G] or less, 10 to 55 Hz
	Shock resistance	During storage	98 m/s ² [10.0 G] or less
Working atmosphere		No corrosive gases, dust or oil mist	
Power specifications	Power supply voltage		24 VDC ±5% Ripple noise 240 mV (P-P)
	Current consumption	(max.)	0.2A
	Instantaneous stop tolerance time		24 VDC : 4 ms or less
Others	Heating value		4 W (max.)
	Mass		0.6 kg

(*1) "Short term" means within one month.

Note

(1) The unit is an IP65F equivalent.

Dimension and names of parts

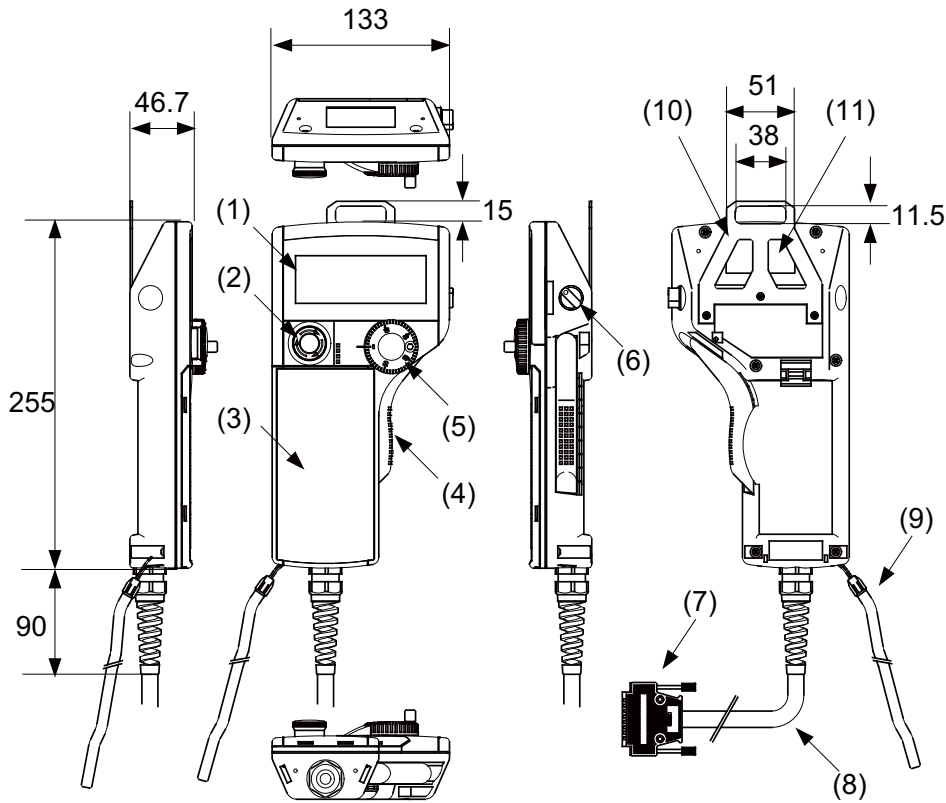

No.	Name	Function/Specification	No.	Name	Function/Specification
(1)	LCD	Monochrome display with backlight 192 (W) × 64 (H) dots	(7)	HOST	Host interface connector (DDK: 17JE-23250-02(D8A6))
(2)	SW1	Emergency stop switch Contact rating/Contact: 24 VDC, 1A Contact configuration: 2b contacts (IDEC Corporation: HA1E-V2S2VR)	(8)	-	Host interface cable (5 m)
(3)	-	Membrane switch (*1)	(9)	-	Simplified hand strap (IDEC Corporation: HG9Z-PS1)
(4)	SW2	Enable switch Contact rating/Contact: 24 VDC , 50 mA Contact configuration: 3-position contact × 2 (OFF-ON-OFF) (IDEC Corporation: HE3B-M2)	(10)	-	Panel mounting bracket (IDEC Corporation: HG9Z-TK1)
(5)	SW4	Manual Pulse Generator Output: Open collector 4.7 kΩ pull-up resistor is connected. (TOKYO SOKUTEIKIZAI CO., LTD: RE19PH50C16RR)	(11)	-	Serial number plate
(6)	SW6	Selector switch			

(*1) Do not press multiple switches simultaneously: When three or more switches are pressed simultaneously, unpressed switches are also detected as pressed ones.

4.17 Thermistor

4.17.1 Thermistor(PT3C-51F-M2)

Outline dimensions

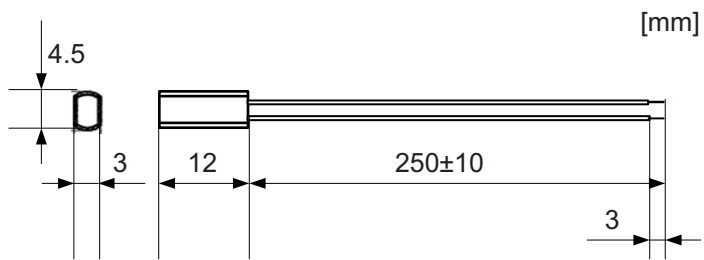

Made by SHIBAURA ELECTRONICS Co., Ltd.

Ambient temperature	-10 to + 190 °C
Insulation resistance	100 MΩ or more at 500 VDC [between case and lead wire]

4.18 Exclusive SD Cards

Item		FCU8-SD001G	FCU8-SD004G
Capacity		1 GB	4 GB
NAND Flash		SLC (*1)	
Ambient temperature	During operation	-25 °C to +85 °C	
	During storage	-40 °C to +85 °C	
Ambient humidity	During operation	5% to 95%RH (with no dew condensation)	
	During storage	5% to 95%RH (with no dew condensation)	

(*1) SLC stands for Single Level Cell, and it stores one bit data in each memory cell.

This provides longer life span and high product reliability in comparison with MLC (Multi Level Cell) and TLC (Triple Level Cell), which are commonly applied to SD cards.

Note

(1) Do not touch the terminal part with fingers, etc. when handling the SD cards.

The contamination of the terminal part of SD card causes a contact failure or a trouble.

4.19 Specifications and Precautions of USB/SD/LAN/Wireless LAN/HDMI Interface

4.19.1 USB Interface (Memory I/F card)

Standards	USB2.0
Data transfer speed (*1)	High Speed (480 Mbps) Full Speed (12 Mbps) Low Speed (1.5 Mbps)
Power supply to USB device	Supply voltage: 5 V \pm 5% Supply current: Max. 500 mA/port
Number of free ports	Front \times 1
Maximum cable length	5 m

(*1) Data transfer speed is the theoretical value on the standard, and the actual speed will be inferior to the value listed above. The transfer speed may be restrained depending on the specification of the connected device.

Note

(1) Do not connect the devices other than the USB memory.

■ Precautions for insertion/removal of USB memory

When inserting/removing a USB memory, turn the Mitsubishi Electric device's power OFF. Do not pull out the USB memory or turn OFF the power during access to the USB memory. Failure to observe this could cause the memory contents to be erased.

When inserting/removing a USB memory, be sure to have enough interval to perform that (about 10 seconds or more).

In case of emergency, always perform backups by having your important data duplicate, etc. as Mitsubishi Electric will not guarantee the broken or lost data.

■ Precaution for operation with front-side USB memory

A USB memory to be used has to be supported USB2.0 Hi-Speed (480 Mbps).

When connecting the USB memory, connect it directly without using the extension cable or USB hub.

Machine vibration may cause the USB memory to fall out depending on environment. Therefore, the operation with the front-side USB memory is required to be performed on your own responsibility.

■ Static electricity

Static electricity may cause malfunction of USB memory. Before using the USB memory, make sure to touch a conductive material such as a grounded metal object to discharge static electricity accumulated in human body, etc.

4.19.2 USB Interface (Image Input Expansion Unit)

Standards	USB2.0
Data transfer speed (*1)	High Speed (480 Mbps) Full Speed (12 Mbps) Low Speed (1.5 Mbps)
Number of free ports	Image input expansion unit \times 1

(*1) Data transfer speed is the theoretical value on the standard, and the actual speed will be inferior to the value listed above. The transfer speed may be restrained depending on the specification of the connected device.

Note

(1) Do not connect any cables or devices other than USB Type A cable.

■ Precautions for insertion/removal of USB cable

When inserting/removing a USB cable, turn the Mitsubishi Electric device's power OFF. If the cable is inserted/removed while the power is ON, an overvoltage is applied to the IC mounted inside the Mitsubishi Electric device, which may cause a failure.

4.19.3 SD Interface (Memory I/F card)

Standards	SD/SDHC (*1)
Transfer speed	According to the connecting SD card
Maximum capacity	32 GB
Number of free ports	Front × 1, Rear × 1

(*1) SDXC is not supported.

■ Precautions for use of commercially available SD card

Mitsubishi Electric will not provide performance guarantee and maintenance for commercially available SD card, mini SD card or micro SD card (requires converting adapter). When any of them is to be used, careful performance check must be required by the machine tool builder.

Commercially available devices may not be compatible with Mitsubishi Electric units or suitable FA environment for temperature- or noise-wise.

■ Precautions for insertion/removal of SD card

When inserting/removing an SD card, turn the Mitsubishi Electric device's power OFF. Do not pull out the card or turn OFF the power during access to the SD card. Failure to observe this could cause the memory contents to be erased.

In case of emergency, always perform backups by having your important data duplicate, etc. as Mitsubishi Electric will not guarantee the broken or lost data.

■ Static electricity

Static electricity may cause malfunction of SD card. Before using the SD card, make sure to touch a conductive material such as a grounded metal object to discharge static electricity accumulated in human body, etc.

4.19.4 LAN Interface (Control Unit)

Standards	100BASE-TX/10BASE-T
Data transfer speed(*1)	100 Mbps/10 Mbps
Number of free ports	Control unit × 2

(*1) Data transfer speed is the theoretical value on the standard, and the actual speed will be inferior to the value listed above. The transfer speed may be restrained depending on the specification of the connected device.

■ Note

(1) When half-duplex communication is made, the response time may become long depending on the connected device. Use full-duplex communication to connect with the opposite device via a switching HUB.

■ Precautions for selection of LAN cable

Make sure to select the LAN cables which are "category 5e or above" and "shielded". Cable wire material with double shielded, which is appropriate for FA environment, is recommended.

4.19.5 Wireless LAN Interface (Control Unit)

Compatible standards		IEEE802.11b/IEEE802.11g/IEEE802.11a/IEEE802.11n
Data transfer speed (*1)		11 Mbps/54 Mbps/54 Mbps/150 Mbps
Communication frequency band		2.4/5 GHz band
Operation mode		Infrastructure mode (AP/STA) (*2)
Supported channel (*3)	AP mode	1-13 ch, 36-48 ch (W52), 149-165 ch (W58)
	STA mode	Automatically track the connected AP.
Maximum connectable number in AP mode		5 pieces
Security		WEP WPA-PSK WPA2-PSK
Number of antennas		1 (built-in chip antenna)

(*1) Data transfer speed is the theoretical value on the standard, and the actual speed will be inferior to the value listed above. The transfer speed may be restrained depending on the specification of the connected device.

(*2) "AP" is the access point or the parent device, and "STA" is the station or the child device.

(*3) The supported channel depends on the setting of the country code.

■ Name of this function

This product has not received Wi-Fi certification. Use terms such as "wireless LAN", "WLAN", etc.

4.19.6 HDMI Interface (Image Input Expansion Unit)

Standards	HDMI Type A High Speed
Input resolution	Full HD (*1) HD SXGA XGA VGA
Number of free ports	Image input expansion unit x 1

(*1) The maximum available input resolution of the image signals is Full HD, but the resolution of the display units for Mitsubishi Electric is 19-type (SXGA), 15-type (VGA) and 10.4-type (VGA).

■ Note

(1) Do not connect any cables or devices other than HDMI Type A cable.

■ Precautions for insertion/removal of HDMI cable

When inserting/removing an HDMI cable, turn the Mitsubishi Electric device's power OFF. If the cable is inserted/removed while the power is ON, an overvoltage is applied to the IC mounted inside the Mitsubishi Electric device, which may cause a failure.

Revision History

Date of revision	Manual No.	Revision details
Mar. 2021	IB(NA)1501611-A	The first edition was created.
Jul. 2021	IB(NA)1501611-B	<p>Contents were revised to correspond to Mitsubishi Electric CNC M800VS/M80V Series.</p> <p>Part "M800VS/M80V Series Hardware" was added.</p> <p>Other mistakes were corrected.</p>
Mar. 2022	IB(NA)1501611-C	<p>Contents were revised to correspond to Mitsubishi Electric CNC M800V/M80V Series software version A3.</p> <p>"M800VW/M80VW Series Hardware"</p> <p>The following units were added.</p> <ul style="list-style-type: none"> • FCU8-DX522-001 (Laser I/F Unit) <p>The following chapters were added.</p> <ul style="list-style-type: none"> • 2.3 19-type Display Unit • 2.4 Connecting a Laser I/F Unit • 3.9 Laser I/F Unit • 4.11 Laser I/F Unit <p>The following chapters were changed.</p> <ul style="list-style-type: none"> • 2.1 M800VW Series, Windows-based Display Unit • 2.2 M80VW Series, Windows-based Display Unit • 3.16 Cable Connector Sets • 3.19 Durable Parts • 3.20 Replacements • 4.1.1 Environment Conditions Inside the Operation Panel • 4.1.2 Environment Conditions Inside the Control Panel • 4.2.1 Environment Conditions Inside the Operation Panel • 4.2.2 Environment Conditions Inside the Control Panel • 4.20.1 USB Interface (Personal Computer Unit, Side Memory I/F Unit) • 4.20.2 SD Interface (Control Unit, Side Memory I/F Unit) • 4.20.3 LAN Interface (Control Unit, Personal Computer Unit) <p>"M800VS/M80V Series Hardware"</p> <p>The following units were added.</p> <ul style="list-style-type: none"> • FCU8-DU194-31 (19-type color LCD touchscreen) • FCU8-DU194-32 (19-type color LCD touchscreen) • FCU8-KB091 (Keyboard for 19-type display unit) • FCU8-DX522-001 (Laser I/F Unit) • FCU8-EX752 (Image input expansion unit) <p>The following chapters were added.</p> <ul style="list-style-type: none"> • 2.3 19-type Display Unit • 2.6 Connecting a BiSS Encoder • 2.7 Connecting an Image Input Expansion Unit • 2.8 Connecting a Laser I/F Unit • 3.9 Laser I/F Unit • 4.5.3 19-type (FCU8-DU194-31) • 4.6.4 19-type (FCU8-DU194-32) • 4.7.10 Keyboard for 19-type Display Unit (FCU8-KB091) • 4.10 Laser I/F Unit • 4.12.7 Image Input Expansion Unit (FCU8-EX752) • 4.19.2 USB Interface (Image Input Expansion Unit) • 4.19.5 Wireless LAN Interface (Control Unit) • 4.19.6 HDMI Interface (Image Input Expansion Unit) <p>The following chapters were changed.</p> <ul style="list-style-type: none"> • 2.1 M800VS Series • 2.2 M80V Series • 2.4 Connecting an Operation Panel I/O Unit (FCU8-DX834) • 2.5 Connecting a Pulse-controlled Inverter (M80V Series) • 3.3 Display Unit [M800VS] • 3.4 Display Unit [M80V] • 3.5 Keyboard Unit [M800VS] • 3.6 Keyboard Unit [M80V]

(Continue to the next page)

Date of revision	Manual No.	Revision details
		<p style="text-align: right;">(Continued from the previous page)</p> <ul style="list-style-type: none"> ♦ 3.11 Function Expansion Unit ♦ 3.16 Cable Connector Sets ♦ 3.20 Replacements ♦ 3.22 System Type ♦ 4.1.1 Installation Environment Conditions ♦ 4.2.1 Installation Environment Conditions ♦ 4.3.1 FCU8-MU551 / FCU8-MA551 ♦ 4.5.2 15-type (FCU8-DU182-31) ♦ 4.6.3 15-type (FCU8-DU182-32) ♦ 4.7 Keyboard Unit ♦ 4.19.1 USB Interface (Memory I/F card) ♦ 4.19.3 SD Interface (Memory I/F card) <p>Other mistakes were corrected.</p>
Mar. 2023	IB(NA)1501611-D	<p>Contents were revised to correspond to Mitsubishi Electric CNC M800V/M80V Series software version A7.</p> <p>"M800VW/M80VW Series Hardware"</p> <p>The following chapters were changed.</p> <ul style="list-style-type: none"> ♦ 2.1 M800VW Series, Windows-based Display Unit ♦ 2.2 M80VW Series, Windows-based Display Unit ♦ 2.3 19-type Display Unit ♦ 2.4 Connecting a Laser I/F Unit ♦ 3.1 Control Unit [M800VW] ♦ 3.2 Control Unit [M80VW] ♦ 4.1.1 Environment Conditions Inside the Operation Panel ♦ 4.2.1 Environment Conditions Inside the Operation Panel ♦ 4.3.1 M830VW(FCU8-MU052)/M850VW(FCU8-MA051) ♦ 4.4.1 FCU8-MU054 ♦ 4.10.2 FCU8-DX220/FCU8-DX230/FCU8-DX231/FCU8-DX202/FCU8-DX213/ FCU8-DX213-1/ FCU8-DX654/FCU8-DX654-1/FCU8-DX651/FCU8-DX408/ FCU8-DX409 ♦ 4.16.1 Main Panels A/B (FCU8-KB921/FCU8-KB922/FCU8-KB925, FCU8-KB923/FCU8-KB924/ FCU8-KB926) <p>"M800VS/M80V Series Hardware"</p> <p>The following chapter was added.</p> <ul style="list-style-type: none"> ♦ 2.9 Connecting an EcoMonitorLight <p>The following chapters were changed.</p> <ul style="list-style-type: none"> ♦ 2.1 M800VS Series ♦ 2.2 M80V Series ♦ 2.3 19-type Display Unit ♦ 4.3.1 FCU8-MU551 / FCU8-MA551 ♦ 4.9.2 FCU8-DX220/FCU8-DX230/FCU8-DX231/FCU8-DX202/FCU8-DX213/ FCU8-DX213-1/ FCU8-DX654/FCU8-DX654-1/FCU8-DX651/FCU8-DX408/ FCU8-DX409 ♦ 4.15.1 4.15.1 Main Panels A/B (FCU8-KB921/FCU8-KB922/FCU8-KB925, FCU8-KB923/FCU8-KB924/FCU8-KB926) <p>Other mistakes were corrected.</p>

Date of revision	Manual No.	Revision details
Jul. 2023	IB(NA)1501611-E	<p>Contents were revised to correspond to Mitsubishi Electric CNC M800V/M80V Series software version A8.</p> <p>"M800VW/M80VW Series Hardware"</p> <p>The following chapter was changed.</p> <ul style="list-style-type: none"> ♦ 3.21 List of Cables <p>"M800VS/M80V Series Hardware"</p> <p>The following chapters were changed.</p> <ul style="list-style-type: none"> ♦ 2.3 19-type Display Unit ♦ 2.7 Connecting an Image Input Expansion Unit ♦ 3.6 Keyboard Unit [M80V] ♦ 3.21 List of Cables ♦ 4.2.1 Installation Environment Conditions ♦ 4.7 Keyboard Unit <p>The following chapter was deleted.</p> <ul style="list-style-type: none"> ♦ 4.7.1 Keyboard for 8.4-type Display Unit (FCU8-KB025) <p>Other mistakes were corrected.</p>

Global Service Network

AMERICA

MITSUBISHI ELECTRIC AUTOMATION INC. (AMERICA FA CENTER)

Central Region Service Center (Chicago)
500 CORPORATE WOODS PARKWAY, VERNON HILLS, ILLINOIS 60061, U.S.A.
TEL: +1-847-478-2500 / FAX: +1-847-478-2650
Minneapolis, MN Service Satellite
Detroit, MI Service Satellite
Grand Rapids, MI Service Satellite
Milwaukee, WI Service Satellite
Cleveland, OH Service Satellite
Indianapolis, IN Service Satellite
St. Louis, MO Service Satellite

South/East Region Service Center (Georgia)

1845 SATELLITE BOULEVARD STE. 450, DULUTH, GEORGIA 30097, U.S.A.
TEL: +1-678-258-4529 / FAX: +1-678-258-4519
Charleston, SC Service Satellite
Charlotte, NC Service Satellite
Raleigh, NC Service Satellite
Dallas, TX Service Satellite
Houston, TX Service Satellite
Hartford, CT Service Satellite
Knoxville, TN Service Satellite
Nashville, TN Service Satellite
Baltimore, MD Service Satellite
Pittsburg, PA Service Satellite
Tampa, FL Service Satellite
Syracuse, NY Service Satellite
Orlando, FL Service Satellite
Lafayette, LA Service Satellite
Philadelphia, PA Service Satellite

Western Region Service Center (California)

5900-B KATELLA AVE. - 5900-A KATELLA AVE. CYPRESS, CALIFORNIA 90630, U.S.A.
TEL: +1-714-699-2625 / FAX: +1-847-478-2650
San Jose, CA Service Satellite
Seattle, WA Service Satellite
Denver, CO Service Satellite

Canada Region Service Center (Toronto)

4299 14TH AVENUE MARKHAM, ONTARIO L3R 0J2, CANADA
TEL: +1-905-475-7728 / FAX: +1-905-475-7935
Edmonton, AB Service Satellite
Montreal, QC Service Satellite

Mexico Region Service Center (Querétaro)

Parque Tecnológico Innovación Querétaro, Lateral Carretera Estatal 431, Km 2+200, Lote 91 Modulos 1 y 2
Hacienda la Machorra, CP 76246, El Marqués, Querétaro, México
TEL: +52-442-153-6050
Monterrey, NL Service Satellite
Mexico City, DF Service Satellite

BRAZIL

MITSUBISHI ELECTRIC DO BRASIL COMÉRCIO E SERVIÇOS LTDA.

Votorantim Office
AV. GISELE CONSTANTINO,1578, PARQUE BELA VISTA, VOTORANTIM-SP, BRAZIL CEP:18.110-650
TEL: +55-15-3023-9000
Blumenau, Santa Catarina Office

EUROPE

MITSUBISHI ELECTRIC EUROPE B.V.

European Service Headquarters (Dusseldorf, GERMANY)
Mitsubishi-Electric-Platz 1 40882 RATINGEN, GERMANY
TEL: +49-2102-486-5000 / FAX: +49-2102-486-5910

South Germany Service Center (Stuttgart)

SCHELMENWASENSTRASSE 16-20, 70567 STUTTGART, GERMANY
TEL: +49-711-770598-0 / FAX: +49-711-770598-141

France Service Center (Paris)

2 RUE DE L'UNION, 92565 RUEIL-MALMAISON CEDEX, FRANCE
TEL: +33-1-41-02-83-13 / FAX: +33-1-49-01-07-25

France Service Satellite (Lyon)

240, ALLEE JACQUES MONOD 69800 SAINT PRIEST FRANCE
TEL: +33-1-41-02-83-13 / FAX: +33-1-49-01-07-25

Italy Service Center (Milan)

VIA ENERGY PARK 14, VIMERCATE 20871 (MB) ITALY
TEL: +39-039-6053-342 / FAX: +39-039-6053-206

Italy Service Satellite (Padova)

VIA G. SAVELLI, 24 - 35129 PADOVA, ITALY
TEL: +39-039-6053-342 / FAX: +39-039-6053-206

U.K. Service Center

TRAVELLERS LANE, HATFIELD, HERTFORDSHIRE, AL10 8XB, U.K.
TEL: +44-1707-288-780 / FAX: +44-1707-278-695

Spain Service Center

CTRA. RUBI, 76-80 8174 SAINT CUGAT DEL VALLES, BARCELONA, SPAIN
TEL: +34-935-65-2236 / FAX: +34-935-89-1579

Poland Service Center

UL.KRAKOWSKA 50, 32-083 BALICE, POLAND
TEL: +48-12-347-6500 / FAX: +48-12-630-4701

Hungary Service Center

BUDAÖRS OFFICE PARK, SZABADSÁG ÚT 117., 2040 BUDAÖRS, HUNGARY
TEL: +48-12-347-6500 / FAX: +48-12-630-4701

Turkey Service Center

MITSUBISHI ELECTRIC TURKEY ELEKTRİK ÜRÜNLERİ A.Ş
SERIFALI MAHALLESİ KALE SOKAK, NO.41 34775
UMRANIYE, ISTANBUL, TURKEY
TEL: +90-216-969-2500 / FAX: +90-216-661-44-47

Czech Republic Service Center

AutoCont Control Systems s.r.o (Service Partner)
KAFKOVA 1853/3, 702 00 OSTRAVA 2, CZECH REPUBLIC
TEL: +420-59-5691-185 / FAX: +420-59-5691-199

Russia Service Center

MITSUBISHI ELECTRIC RUSSIA LLC
LETNIKOVSKAYA STREET 2, BLD.1, 5TH 115114 MOSCOW, RUSSIA
TEL: +7-495-721-2070 / FAX: +7-495-721-2071

Sweden Service Center

HAMMARBACKEN 14, P.O.BOX 750 SE-19127, SOLLENTUNA, SWEDEN
TEL: +46-8-6251200 / FAX: +46-8-6251014

Bulgaria Service Center

AKHNATON Ltd. (Service Partner)
4 ANDREJ LJAPCHEV BLVD. POB 21, BG-1756 SOFIA, BULGARIA
TEL: +359-2-8176009 / FAX: +359-2-9744061

Ukraine Service Center (Kiev)

CSC Automation Ltd. (Service Partner)
4 B. YEVHENA SVERTYUKA STR., 02002 KIEV, UKRAINE
TEL: +380-44-494-3344 / FAX: +380-44-494-3366

Belarus Service Center

TECHNIKON Ltd. (Service Partner)
NEZAVISIMOSTI PR.177, 220125 MINSK, BELARUS
TEL: +375-17-393-1177 / FAX: +375-17-393-0081

South Africa Service Center

Adroit Technologies (Service Partner)
20 WATERFORD OFFICE PARK, WATERFORD DRIVE, CNR OF WITKOPPEN ROAD,
FOURWAYS JOHANNESBURG SOUTH AFRICA
TEL: +27-11-658-6100 / FAX: +27-11-658-6101

ASEAN**MITSUBISHI ELECTRIC ASIA PTE. LTD. (ASEAN FA CENTER)**

Singapore Service Center
307 ALEXANDRA ROAD MITSUBISHI ELECTRIC BUILDING SINGAPORE 159943
TEL: +65-6473-2308 / FAX: +65-6476-7439

PHILIPPINES**MELCO FACTORY AUTOMATION PHILIPPINES INC.**

Head Office
128 LOPEZ RIZAL STREET, BRGY., HIGHWAY HILLS, MANDALUYONG CITY, MM PHILIPPINES 1550
TEL: +63-2-8256-8042 / FAX: +632-8637-2294

Philippines Service Center

KM.23 WEST SERVICE ROAD SSH, CUPANG, MUNTINLUPA CITY, PHILIPPINES
TEL: +63-2-8807-0420 / FAX: +63-2-8842-5202

VIETNAM**MITSUBISHI ELECTRIC VIETNAM CO., LTD.**

Vietnam Ho Chi Minh Service Center
11TH & 12TH FLOOR, VIETTEL TOWER B, 285 CACH MANG THANG 8 STREET, WARD 12, DISTRICT 10,
HO CHI MINH CITY, VIETNAM
TEL: +84-28-3910-5945 / FAX: +84-28-3910-5947

Vietnam Hanoi Service Center

14TH FLOOR, CAPITAL TOWER, 109 TRAN HUNG DAO STREET, CUA NAM WARD,
HOAN KIEM DISTRICT, HA NOI CITY, VIETNAM
TEL: +84-24-3937-8075 / FAX: +84-24-3937-8076

INDONESIA**PT. MITSUBISHI ELECTRIC INDONESIA**

Indonesia Service Center (Cikarang)
JL. KENARI RAYA BLOK G2-07A, DELTA SILICON 5, LIPPO CIKARANG - BEKASI 17550, INDONESIA
TEL: +62-21-2961-7797 / FAX: +62-21-2961-7794

MALAYSIA**MITSUBISHI ELECTRIC SALES MALAYSIA SDN. BHD.**

Malaysia Service Center (Kuala Lumpur Service Center)
LOT 11, JALAN 219, P.O BOX 1036, 46860 PETALING JAYA, SELANGOR DARUL EHSAN, MALAYSIA
TEL: +60-3-7626-5032
Johor Bahru Service Satellite
Pulau Pinang Service Satellite

THAILAND**MITSUBISHI ELECTRIC FACTORY AUTOMATION (THAILAND) CO., LTD.**

Thailand Service Center (Bangkok)
101, TRUE DIGITAL PARK OFFICE, 5TH FLOOR, SUKHUMVIT ROAD, BANGCHAK, PHRA KHANONG,
BANGKOK, 10260 THAILAND
TEL: +66-2-092-8600 / FAX: +66-2-043-1231-33

INDIA**MITSUBISHI ELECTRIC INDIA PVT., LTD.**

CNC Technical Center (Bangalore)
PLOT NO. 56, 4TH MAIN ROAD, PEENYA PHASE 3,
PEENYA INDUSTRIAL AREA, BANGALORE 560058, KARNATAKA, INDIA
TEL: +91-80-4655-2121
Chennai Service Satellite
Coimbatore Service Satellite
Hyderabad Service Satellite

North India Service Center (Gurgaon)

PLOT 517, GROUND FLOOR, UDYOG VIHAR PHASE-III, GURUGRAM 122008, HARYANA, INDIA
TEL: +91-124-463-0300
Ludhiana Service Satellite
Panthenagar Service Satellite
Delhi Service Satellite
Jamshedpur Service Satellite
Manesar Service Satellite

West India Service Center (Pune)

ICC-Devi GAURAV TECHNOLOGY PARK, UNIT NO.402, FOURTH FLOOR, NORTH WING,
SURVEY NUMBER 191-192 (P), NEXT to INDIAN CARD CLOTHING COMPANY Ltd,
OPP. VALLABH NAGAR, PIMPRI, PUNE- 411 018, MAHARASHTRA, INDIA
TEL: +91-20-6819-2274
Kolhapur Service Satellite
Aurangabad Service Satellite
Mumbai Service Satellite

West India Service Center (Ahmedabad)

204-209, 2ND FLOOR, 31FIVE, CORPORATE ROAD PRAHLADNAGAR,
AHMEDABAD -390015, GUJARAT, INDIA
TEL: + 91-79-6777-7888
Rajkot Service Satellite

CHINA**MITSUBISHI ELECTRIC AUTOMATION (CHINA) LTD. (CHINA FA CENTER)**

CNC Call Center
TEL: +86-400-921-5130

Shanghai Service Center

NO.1386 HONG QIAO ROAD, CHANG NING QU, SHANGHAI 200336, CHINA
TEL: +86-21-2322-3030 / FAX: +86-21-2322-3000*8422

Qingdao Service Center**Suzhou Service Center****Wuhan Service Center****Ningbo Service Center****Hefei Service Center****Beijing Service Center****Tianjin Service Center****Xian Service Center****Dalian Service Center****Chengdu Service Center****Shenzhen Service Center**

LEVEL8, GALAXY WORLD TOWER B, 1 YABAO ROAD, LONGGANG DISTRICT,
SHENZHEN 518129, CHINA
TEL: +86-755-2399-8272 / FAX: +86-755-8229-3686

Dongguan Service Center**Xiamen Service Center****KOREA****MITSUBISHI ELECTRIC AUTOMATION KOREA CO., LTD. (KOREA FA CENTER)**

Korea Service Center
8F GANGSEO HANGANG XI-TOWER A, 401 YANGCHEON-RO, GANGSEO-GU,
SEOUL 07528 KOREA
TEL: +82-2-3660-9631 / FAX: +82-2-3664-8668
Korea Daegu Service Satellite

TAIWAN**MITSUBISHI ELECTRIC TAIWAN CO., LTD. (TAIWAN FA CENTER)**

Taiwan Taichung Service Center
NO. 8-1, GONGYEQU 16th RD., XITUN DIST., TAICHUNG CITY 40768, TAIWAN
TEL: +886-4-2359-0688 / FAX: +886-4-2359-0689

Taiwan Taipei Service Center

11F, NO.88, SEC.6, ZHONGSHAN N. RD., SHILIN DIST., TAIPEI CITY 11155, TAIWAN
TEL: +886-2-2833-5430 / FAX: +886-2-2833-5433

Taiwan Tainan Service Center

11F.-1, NO.30, ZHONGZHENG S. RD., YONGKANG DIST., TAINAN CITY 71067, TAIWAN
TEL: +886-6-252-5030 / FAX: +886-6-252-5031

OCEANIA**MITSUBISHI ELECTRIC AUSTRALIA PTY. LTD.**

Oceania Service Center
348 VICTORIA ROAD, RYDALMERE, N.S.W. 2116 AUSTRALIA
TEL: +61-2-9684-7269 / FAX: +61-2-9684-7245

Notice

Every effort has been made to keep up with software and hardware revisions in the contents described in this manual. However, please understand that in some unavoidable cases simultaneous revision is not possible. Please contact your Mitsubishi Electric dealer with any questions or comments regarding the use of this product.

Duplication Prohibited

This manual may not be reproduced in any form, in part or in whole, without written permission from Mitsubishi Electric Corporation.

COPYRIGHT 2021-2023 MITSUBISHI ELECTRIC CORPORATION ALL RIGHTS RESERVED

MITSUBISHI ELECTRIC CORPORATION

HEAD OFFICE : TOKYO BLDG.,2-7-3 MARUNOUCHI,CHIYODA-KU,TOKYO 100-8310,JAPAN

MODEL	M800V/M80V Series
MODEL CODE	100-742
Manual No.	IB-1501611