

Numerical Control (CNC) NC Specification Selection Guide M800/M80/E80/C80 Series



- **M800W Series**
- **M800S Series**
- **M80W Series**
- **M80 Series**
- **E80 Series**
- **C80 Series**

GLOBAL IMPACT OF MITSUBISHI ELECTRIC



Through Mitsubishi Electric's vision, "Changes for the Better" are possible for a brighter future.

Changes for the Better

"Changes for the Better" represents the Mitsubishi Electric Group's attitude to "always strive to achieve something better", as we continue to change and grow. Each one of us shares a strong will and passion to continuously aim for change, reinforcing our commitment to creating "an even better tomorrow".

Mitsubishi Electric is involved in many areas including the following:

Energy and Electric Systems

A wide range of power and electrical products from generators to large-scale displays.

Electronic Devices

A wide portfolio of cutting-edge semiconductor devices for systems and products.

Home Appliance

Dependable consumer products like air conditioners and home entertainment systems.

Information and Communication Systems

Commercial and consumer-centric equipment, products and systems.

Industrial Automation Systems

Maximizing productivity and efficiency with cutting-edge automation technology.

Our advances in AI and IoT are adding new value to society in diverse areas from automation to information systems. The creation of game-changing solutions is helping to transform the world, which is why we are honored to be recognized in the 2019 "Forbes Digital 100" as one of world's most influential digital corporations.



OVERVIEW

- CNC LINEUP3
- SELECTION PROCEDURE4
- PRODUCT LINES (M800/M80/E80 Series).....5
- PRODUCT LINES (C80 Series)7
- M800/M80/E80/C80 SERIES LINEUP.....9
- CNC SYSTEM.....11
 - M800/M80/E80/C80 SERIES SPECIFICATIONS LIST 11
 - CONTROL UNIT/DISPLAY UNIT 47
 - GENERAL CONNECTION DIAGRAM..... 53
 - HARDWARE..... 45
 - I/O UNIT AND OTHERS..... 49
 - LIST OF CABLES 69
- DRIVE SYSTEM.....77
 - SYSTEM CONFIGURATION..... 79
 - SPECIFICATIONS..... 85
 - TYPE..... 87
- SERVO MOTOR /DIRECT-DRIVE MOTOR /LINEAR SERVO MOTOR 200V ...96
 - HG Series..... 96
 - TM-RB Series..... 99
 - LM-F Series..... 100
- SPINDLE MOTOR /BUILT-IN SPINDLE MOTOR /TOOL SPINDLE MOTOR 200V...102
 - SJ-D Series 102
 - SJ-DL Series 106
 - SJ-VL Series..... 111
 - SJ-PMB Series..... 120
 - SJ-DG Series 104
 - SJ-DN Series..... 107
 - SJ-BG Series..... 112
 - HG-JR Series 121
 - SJ-DJ Series 105
 - SJ-V Series 108
 - SJ-B Series 116
 - HG Series..... 121
- SERVO MOTOR /LINEAR SERVO MOTOR 400V.....123
 - HG-H Series 123
 - HQ-H Series 124
 - LM-F Series..... 125
- SPINDLE MOTOR /BUILT-IN SPINDLE MOTOR /TOOL SPINDLE MOTOR 400V...126
 - SJ-4-V Series 126
 - HG-JR Series 130
 - SJ-4BG Series..... 128
 - SJ-4BGS Series 129
- DRIVE UNIT131
 - MDS-E Series..... 131
 - MDS-EJ/EJH Series 138
 - MDS-EH Series 133
 - MDS-EX-CVP Series 141
 - MDS-EM/EMH Series..... 136
- SELECTION143
- DRIVE SYSTEM DEDICATED OPTIONS/CABLES.....156
 - SERVO OPTIONS..... 156
 - ENCODER INTERFACE UNIT 167
 - SELECTION OF CABLES AND CONNECTORS... 176
 - SPINDLE OPTIONS..... 161
 - DRIVE UNIT OPTION..... 170
 - LIST OF CABLES 187
- SOFTWARE TOOLS193
- GLOBAL SALES & SERVICE NETWORK195

(Note) The characteristic values and numerical values without tolerances mentioned in this manual are representative values.



CNC LINEUP

M800W

**Premium CNC provides expandability and flexibility**

- Separated type, a control unit separated from display
- Windows-based display is included in the lineup, which provides excellent expandability
- Four expansion slots are provided as standard specifications, allowing for expansion using option card slot

M800S

**High-grade CNC well suited to high-speed high-accuracy machining and multi-axis multi-part system control**

- Panel-in type, a control unit with integrated display
- Multi-CPU architecture allows for high performance and high functional graphics
- Non-Windows-based display provides easy operability

M80W

**Standard CNC with expandability and flexibility**

- Separated type, a control unit separated from display
- Windows-based display is included in the lineup, which provides excellent expandability
- Packaged type for selecting a machine type easily
- Two expansion slots are provided as standard specifications, allowing for expansion using option cards slot

M80

**Standard CNC provides high productivity and easy operability**

- Panel-in type, a control unit with integrated display
- Provided in package (TypeA/TypeB) for easier selection
- Non-Windows-based display provides easy operability

E80

**Simple CNC E80 Series, offering easy operability and high cost performance**

- Panel-in type, a control unit with integrated display
- Provided in package (TypeA/TypeB) for easier selection
- Non-Windows-based display provides easy operability

C80

**iQ Platform compatible CNC C80 Series incorporated with Mitsubishi's state-of-the-art technologies**

- Easy linkage with many and varied MELSEC units.
- MELSEC sequencer for PLC and GOT2000 for display unit are used.
- Three of C80 can be mounted on one base and the control system with up to 21 part systems/48 axes can be established.

SELECTION PROCEDURE

Selection procedure flow chart

Start selecting the NC specifications!

STEP 1	Check the machine type and specifications	
	<ul style="list-style-type: none"> • Machine type: lathe / machining center / grinding machine / special-purpose machine, etc. • Details of control, required accuracy, with/without auxiliary axes (for workpiece feeding, turret, etc.) 	
STEP 2	Decide the NC specifications	P4
	<ul style="list-style-type: none"> • Number of axes, axis configuration, number of part systems, with/without spindles, number of I/O points • Check the position detection method and detection performance (absolute/relative position, number of pulses) • Select the size of the display unit, keyboard 	
STEP 3	Decide the servo motor	P96
	<ul style="list-style-type: none"> • Select the servo motor capacity (NC Servo Selection) • Check the outline dimensions, encoder, and whether it has a scale or break 	
STEP 4	Decide the spindle motor	P102
	<ul style="list-style-type: none"> • Check the spindle's base/maximum rotation speed, output, torque, outline dimensions and whether it has a keyway • Frame-type or built-in spindle motor • With/without optional specifications (orientation, spindle/C-axis, synchronization, etc.) • Check the C axis accuracy and the speed (when C axis is used) 	
STEP 5	Decide the drive unit	P131
	<ul style="list-style-type: none"> • Check the capacity and the dimensions of a drive unit • Check the power regeneration/resistor regeneration 	
STEP 6	Decide the power supply unit	P143
	<ul style="list-style-type: none"> • Select the power supply unit only when a power regenerative drive unit is used 	
STEP 7	Decide the hardware options	P45,P69,P176
	<ul style="list-style-type: none"> • Check the options (manual pulse generator, synchronous encoder, vibration cutting control, availability of network connection and PLC connection, etc.) • Check the required cables and connectors 	
STEP 8	Decide the software options	P11
	<ul style="list-style-type: none"> • Check the number of programs stored (memory capacity), number of variable sets, etc. • Check the required functions 	
STEP 9	Check the development tools	P193
	<ul style="list-style-type: none"> • Check the screen development tool (when screen customization is required) 	

NC specification selection completed!

PRODUCT LINES (M800/M80/E80 Series)

3

PRODUCT LINES (M800/M80/E80 Series)

Ethernet

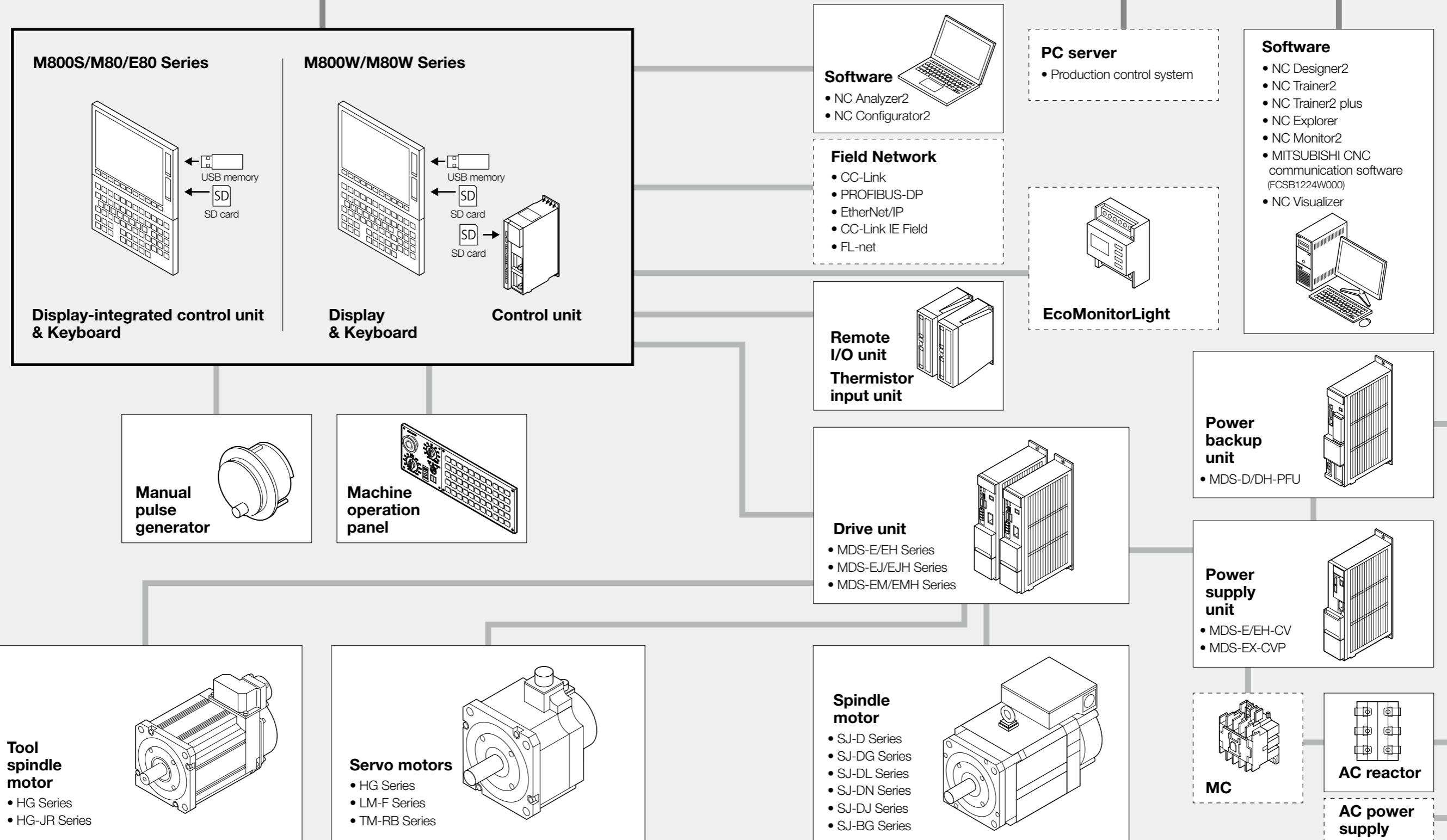

Optional parts are not provided as accessories for NC equipment. Please purchase desired components from a Mitsubishi Electric dealership, etc.

3

PRODUCT LINES (M800/M80/E80 Series)

PRODUCT LINES (C80 Series)

Ethernet

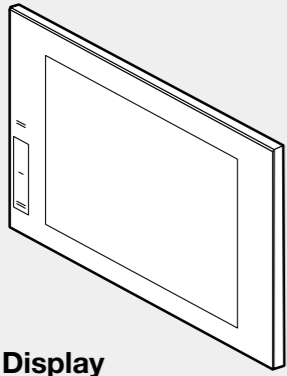

Display
•GOT2000 Series *1

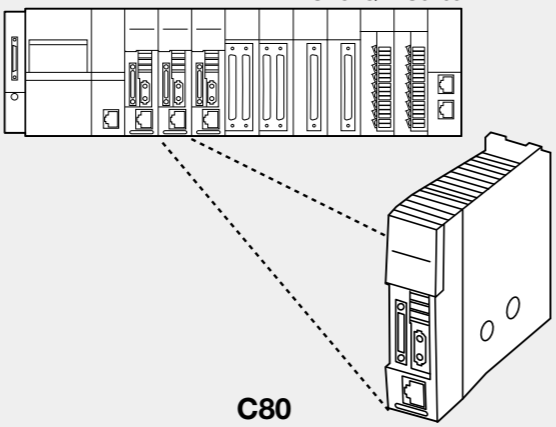

Control unit
MELSEC iQ-R Series
C80

Computer server
•Production control system

Field Network
•CC-Link
•FL-net

Software
•GX Works3
•GT Works3
•NC Analyzer2
•NC Configurator2
•NC Explorer
•NC Monitor2

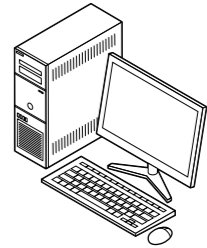
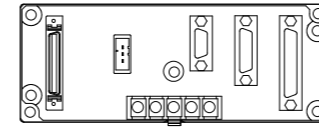
Signal splitter



Manual pulse generator



USB keyboard

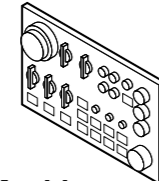

Machine operation panel
* Made by the machine tool builder

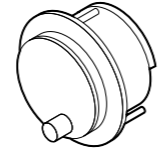

Manual pulse generator

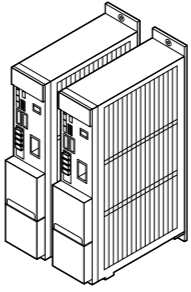

Drive unit *2
•MDS-E/EH Series
•MDS-EJ/EJH Series
•MDS-EM/EMH Series

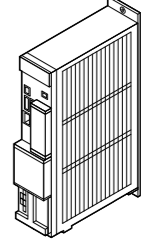

Power backup unit
•MDS-D/DH-PFU

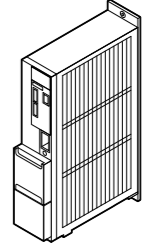

Power supply unit
•MDS-E/EH-CV
•MDS-EX-CVP

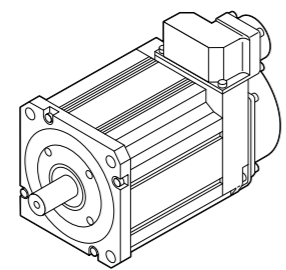

Tool spindle motor *2
•HG Series
•HG-JR Series

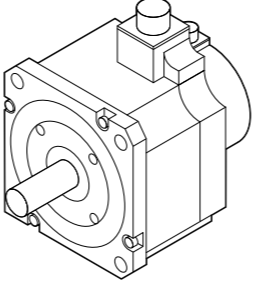

Servo motors *2
•HG Series
•LM-F Series
•TM-RB Series

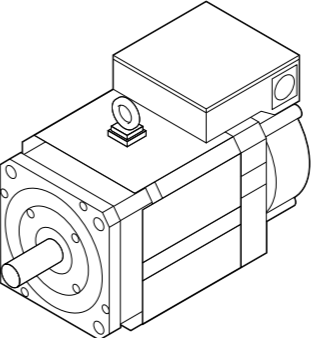

Spindle motor *2
•SJ-D Series
•SJ-DG Series
•SJ-DL Series
•SJ-DN Series
•SJ-DJ Series
•SJ-BG Series

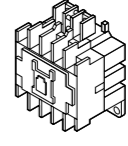

MC

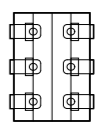

AC reactor



AC power supply

*1 For target models, refer to CNC SYSTEM CONTROL UNIT/DISPLAY UNIT.
*2 Use Mitsubishi CNC's dedicated drive unit and motor.
Optional parts are not provided as accessories for NC equipment.
Please purchase desired components from a Mitsubishi Electric dealership, etc.

M800/M80/E80/C80 SERIES LINEUP

		Lathe system											
		(Display/Control unit separated-type)		(Display/Control unit integrated-type)		(Display/Control unit separated-type)		(Display/Control unit integrated-type)		(Display/Control unit integrated-type)		(Display/Control unit integrated-type)	
Model name		M800W Series		M800S Series		M80W Series		M80 Series		E80 Series		C80 Series	
		M850W	M830W	M850S	M830S	—		TypeA	TypeB	TypeA	TypeB	—	
Number of control axes	Max. number of axes (NC axes + Spindles + PLC axes)	32		32		12		12	9	8	6	16	
	Max. number of NC axes (in total for all the part systems)	32		32		10		10	7	5	4	16	
	Max. number of spindles	8		8		4+G/B ^(*)		4+G/B ^(*)	4	3	3	7	
	Max. number of PLC axes	8		8		6		6		3		8	
	Max. number of PLC indexing axes	8		8		4		4		1	1	8	
	Number of simultaneous contouring control axes	8	4	8	4	4		4		4		4	
	Max. number of NC axes in a part system	12		12		8		8	5	5	4	8	
Max. number of part systems (main + sub)	8		8		4		4	2	1		7		
Max. number of main part systems	8		8		2		2	2	1		7		
Max. number of sub part systems	8		8		2		2	1	—		2		
Control unit-side High-speed program server mode	Available		—		Available		—		—		—		
Display unit-side High-speed program server mode	Available/— ^(*)		Available		Available/— ^(*)		Available		Available		—		
FTP high-speed program server mode	—		—		—		—		—		Available		
Front-side SD card mode	—		—		Available		—		—		—		
Front-side USB memory mode	—		—		Available		—		—		—		
Least command increment	1nm		1nm		0.1µm		0.1µm	0.1µm	0.1µm		0.1µm		
Least control increment	—		—		1nm		—		—		—		
Number of tool offset sets	999		999		256		256	99	99		256		
Max. program capacity	2,000kB (5,120m) (1,000programs)		2,000kB (5,120m) (1,000programs)		500kB (1,280m) (1,000programs)		500kB (1,280m) (1,000programs)		230kB (600m) (400programs)		2,000kB (5,120m) (1,000programs)		
Max. PLC program capacity [steps]	512,000		512,000		64,000		64,000	32,000	20,000		Available (MELSEC)		
Multi-project [number of PLC projects stored]	6		6		3		3	1	1		—		
Interactive cycle insertion	—		—		Available		—		—		—		
High-speed machining mode I maximum [kBPM]	33.7		33.7		33.7		33.7	—	—		33.7		
High-speed machining mode II maximum [kBPM]	168		168		67.5		67.5	—	—		67.5		
High-speed high-accuracy control I maximum [kBPM]	67.5		67.5		33.7		33.7	—	—		33.7		
High-speed high-accuracy control II maximum [kBPM]	168		168		67.5		67.5	—	—		67.5		
High-speed high-accuracy control III maximum [kBPM]	—		—		—		—		—		—		
High-accuracy control	—		—		Available		—		—		Available		
SSS control (Super Smooth Surface)	—		Available		—		(eSSS supported.)		—		—		
Tolerance control	—		—		Available		—		—		—		
CC-Link (Master/Local)	—		—		Available		—		—		Available (MELSEC)		
PROFIBUS-DP (Master)	—		—		Available		—		—		—		
MES interface library	—		—		Available		—		—		—		
Smart Safety observation	—		—		Available		—		—		Available		
Display unit ^(*)	19-type touchscreen, 19-type horizontal touchscreen, 15-type touchscreen, or 10.4-type touchscreen can be selected		15-type touchscreen or 10.4-type touchscreen can be selected		19-type touchscreen, 19-type horizontal touchscreen, 15-type touchscreen, 10.4-type touchscreen, or 8.4-type can be selected		15-type touchscreen, 10.4-type, touchscreen or 8.4-type can be selected		8.4-type		12.1-type touchscreen, 10.4-type touchscreen, 8.4-type touchscreen or 5.7-type touchscreen can be selected		
Windows®8 selection ^(*)	Available/— ^(*)		—		Available/— ^(*)		—		—		—		

* Maximum specifications including optional specifications are listed. Refer to the Specifications List for the details of each option.

(*) Rotary axis up to 1 axis

(*) G/B: Guide Bush

(*) Windows-based display unit/non-Windows-based display unit

(*) For details, refer to "CNC SYSTEM CONTROL UNIT/DISPLAY UNIT" described later.

		Machining center system											
		(Display/Control unit separated-type)		(Display/Control unit integrated-type)		(Display/Control unit separated-type)		(Display/Control unit integrated-type)		(Display/Control unit integrated-type)		(Display/Control unit integrated-type)	
Model name		M800W Series		M800S Series		M80W Series		M80 Series		E80 Series		C80 Series	
		M850W	M830W	M850S	M830S	—		TypeA	TypeB	TypeA	TypeB	—	
Number of control axes	Max. number of axes (NC axes + Spindles + PLC axes)	32		32		11		11	9	6	4	16	
	Max. number of NC axes (in total for all the part systems)	16		16		8		8	6	5 ^(*)	3	16	
	Max. number of spindles	4		4		2		2		1		7	
	Max. number of PLC axes	8		8		6		6		2		8	
	Max. number of PLC indexing axes	8		8		4		4		1		8	
	Number of simultaneous contouring control axes	8	4	8	4	4		4		4		4	
	Max. number of NC axes in a part system	12		12		8		8	5	5 ^(*)	3	8	
Max. number of part systems (main + sub)	2		2		2		2	1	1		7		
Max. number of main part systems	2		2		2		2	1	1		7		
Max. number of sub part systems	2		2		—		—		—		—		
Control unit-side High-speed program server mode	Available		—		Available		—		—		—		
Display unit-side High-speed program server mode	Available/— ^(*)		Available		Available/— ^(*)		Available		Available		—		
FTP high-speed program server mode	—		—		—		—		—		Available		
Front-side SD card mode	—		—		Available		—		—		—		
Front-side USB memory mode	—		—		Available		—		—		—		
Least command increment	1nm		1nm		0.1µm		0.1µm	0.1µm	0.1µm	1µm	0.1µm		
Least control increment	—		—		1nm		—		—		—		
Number of tool offset sets	999		999		400		400	400	200	99	400		
Max. program capacity	2,000kB (5,120m) (1,000programs)		2,000kB (5,120m) (1,000programs)		500kB (1,280m) (1,000programs)		500kB (1,280m) (1,000programs)		500kB (1,280m) (1,000programs)		2,000kB (5,120m) (1,000programs)		
Max. PLC program capacity [steps]	512,000		512,000		64,000		64,000	32,000	20,000		Available (MELSEC)		
Multi-project [number of PLC projects stored]	6		6		3		3	1	1		—		
Interactive cycle insertion	—		—		Available		—		—		—		
High-speed machining mode I maximum [kBPM]	33.7		33.7		33.7		33.7	16.8	—		33.7		
High-speed machining mode II maximum [kBPM]	168		168		67.5		67.5	—	—		67.5		
High-speed high-accuracy control I maximum [kBPM]	67.5		67.5		33.7		33.7	—	—		33.7		
High-speed high-accuracy control II maximum [kBPM]	168		168		67.5		67.5	—	—		67.5		
High-speed high-accuracy control III maximum [kBPM]	270		270		135		135	—	—		135		
High-accuracy control	—		—		Available		—		—		Available		
SSS control (Super Smooth Surface)	—		Available		—		(eSSS supported.)		—		—		
Tolerance control	—		—		Available		—		—		Available		
CC-Link (Master/Local)	—		—		Available		—		—		Available (MELSEC)		
PROFIBUS-DP (Master)	—		—		Available		—		—		—		
MES interface library	—		—		Available		—		—		—		
Smart Safety observation	—		—		Available		—		—		Available		
Display unit ^(*)	19-type touchscreen, 19-type horizontal touchscreen, 15-type touchscreen, or 10.4-type touchscreen can be selected		15-type touchscreen or 10.4-type touchscreen can be selected		19-type touchscreen, 19-type horizontal touchscreen, 15-type touchscreen, 10.4-type touchscreen, or 8.4-type can be selected		15-type touchscreen, 10.4-type, touchscreen or 8.4-type can be selected		8.4-type		12.1-type touchscreen, 10.4-type touchscreen, 8.4-type touchscreen or 5.7-type touchscreen can be selected		
Windows®8 selection ^(*)	Available/— ^(*)		—		Available/— ^(*)		—		—		Available		

CNC SYSTEM M800/M80/E80/C80 SERIES SPECIFICATIONS LIST

○Standard △Optional □Selection Specifications of separated-type display are classified with "Windows-based" and non-Windows-based

[M800/M80/E80]S/W ver.F2 [C80]S/W ver.B7

class	Lathe system										C80	General explanation
	M800W		M800S		M80W	M80		E80		—		
	M850W	M830W	M850S	M830S	—	M80 TypeA	M80 TypeB	E80 TypeA	E80 TypeB			
1 Control axes												
1 Control axes												
1	Number of basic control axes (NC axes)	○2	○2	○2	○2	○2	○2	○2	○2	○2	○2	
2	Max. number of axes (NC axes + Spindles + PLC axes)	○16 △32	○16 △32	○16 △32	○16 △32	12	12	9	8	6	16	
1	Max. number of NC axes (in total for all the part systems)	○16 △32	○16 △32	○16 △32	○16 △32	10	10	7	5	4	16	
2	Max. number of spindles	8	8	8	8	4+G/B*2	4+G/B*2	4	3	3	7	
3	Max. number of PLC axes	8	8	8	8	6	6	6	3	3	8	
4	Max. number of PLC indexing axes	8	8	8	8	4	4	4	1	1	8	
5	Number of simultaneous contouring control axes	8	4	8	4	4	4	4	4	4	4	
6	Max. number of NC axes in a part system	○8 △12	○8 △12	○8 △12	○8 △12	8	8	5	5	4	8	
7	Axis name extension	○	○	○	○	○	○	○	—	—	○	
2 Control part system												
1	Standard number of part systems	1	1	1	1	1	1	1	1	1	1	
2	Max. number of part systems (main + sub)	○4 △8	○4 △8	○4 △8	○4 △8	○4	○4	○2	○1	○1	○7	
1	Max. number of main part systems	○4 △8	○4 △8	○4 △8	○4 △8	○2	○2	○2	○1	○1	○7	
2	Max. number of sub part systems	○4 △8	○4 △8	○4 △8	○4 △8	○2	○2	○1	—	—	○2	
3 Control axes and operation modes												
1	Tape (RS-232C input) mode	○	○	○	○	○	○	○	○	○	—	
2	Memory mode	○	○	○	○	○	○	○	○	○	○	
3	MDI mode	○	○	○	○	○	○	○	○	○	○	
4	High-speed program server mode											
1	Control unit-side High-speed program server mode	△	△	—	—	○	—	—	—	—	—	
2	Display unit-side High-speed program server mode	△/—	△/—	△	△	○/—	○	○	○	○	—	
3	FTP high-speed program server mode	—	—	—	—	—	—	—	—	—	△	
5	Front-side SD card mode	○	○	○	○	○	○	○	○	○	—	
6	Front-side USB memory mode	○	○	○	○	○	○	○	○	○	—	
2 Input command												
1 Data increment												
1	Least command increment											
	Least command increment 1μm	○	○	○	○	○	○	○	○	○	○	
	Least command increment 0.1μm	○	○	○	○	○	○	○	○	○	○	
	Least command increment 0.01μm (10nm)	△	△	△	△	—	—	—	—	—	—	
	Least command increment 0.001μm (1nm)	△	△	△	△	—	—	—	—	—	—	
2	Least control increment											
	Least control increment 0.01μm (10nm)	○	○	○	○	○	○	○	○	○	○	
	Least control increment 0.001μm (1nm)	○	○	○	○	○	○	○	○	○	○	
3	Indexing increment	○	○	○	○	○	○	○	○	○	○	
2 Unit system												
1	Inch / Metric changeover	○	○	○	○	○	○	○	○	○	○	
2	Input command increment tenfold	—	—	—	—	—	—	—	—	—	—	
3 Program format												
1	Program format											
1	Format 1 for Lathe (G Code List 2, 3)	○	○	○	○	○	○	○	○	○	○	
2	Format 2 for Lathe (G Code List 4, 5)	○	○	○	○	○	○	○	○	○	○	
3	Special format for lathe (G Code List 6, 7)	○	○	○	○	○	○	○	○	○	○	
4	Format 1 for Machining center	—	—	—	—	—	—	—	—	—	—	
5	Format 2 for Machining center (M2 format)	—	—	—	—	—	—	—	—	—	—	
6	MITSUBISHI CNC special format	○	○	○	○	○	○	○	○	○	○	
2	Program format switch	△	△	△	△	—	—	—	—	—	—	
4 Command value												
1	Decimal point input I, II	○	○	○	○	○	○	○	○	○	○	
2	Absolute / Incremental command	○	○	○	○	○	○	○	○	○	○	

class	Machining center system										C80	General explanation
	M800W		M800S		M80W	M80		E80		—		
	M850W	M830W	M850S	M830S	—	M80 TypeA	M80 TypeB	E80 TypeA	E80 TypeB			
1 Control axes												
1 Control axes												
1	Number of basic control axes (NC axes)	○3	○3	○3	○3	○3	○3	○3	○3	○3	○3	
2	Max. number of axes (NC axes + Spindles + PLC axes)	○16 △32	○16 △32	○16 △32	○16 △32	11	11	9	6	4	16	
1	Max. number of NC axes (in total for all the part systems)	○16 △32	○16 △32	○16 △32	○16 △32	8	8	6	5*1	3	16	
2	Max. number of spindles	4	4	4	4	2	2	2	1	1	7	
3	Max. number of PLC axes	8	8	8	8	6	6	6	2	0	8	
4	Max. number of PLC indexing axes	8	8	8	8	4	4	4	1	0	8	
5	Number of simultaneous interpolation control axes	8	4	8	4	4	4	4	4	3	4	
6	Max. number of NC axes in a part system	○8 △12	○8 △12	○8 △12	○8 △12	8	8	5	5*	3	8	
7	Axis name extension	○	○	○	○	○	○	○	—	—	○	
2 Control part system												
1	Standard number of part systems	1	1	1	1	1	1	1	1	1	1	
2	Max. number of part systems (main + sub)	○2 △8	○2 △8	○2 △8	○2 △8	○2	○2	○1	○1	○1	○7	
1	Max. number of main part systems	○2 △8	○2 △8	○2 △8	○2 △8	○2	○2	○1	○1	○1	○7	
2	Max. number of sub part systems	○2 △8	○2 △8	○2 △8	○2 △8	○2	○2	○1	—	—	○2	
3 Control axes and operation modes												
1	Tape (RS-232C input) mode	○	○	○	○	○	○	○	○	○	—	
2	Memory mode	○	○	○	○	○	○	○	○	○	○	
3	MDI mode	○	○	○	○	○	○	○	○	○	○	
4	High-speed program server mode											
1	Control unit-side High-speed program server mode	△	△	—	—	○	—	—	—	—	—	
2	Display unit-side High-speed program server mode	△/—	△/—	△	△	○/—	○	○	○	○	—	
3	FTP high-speed program server mode	—	—	—	—	—	—	—	—	—	△	
5	Front-side SD card mode	○	○	○	○	○	○	○	○	○	—	
6	Front-side USB memory mode	○	○	○	○	○	○	○	○	○	—	
2 Input command												
1 Data increment												
1	Least command increment											
	Least command increment 1μm	○	○	○	○	○	○	○	○	○	○	
	Least command increment 0.1μm	○	○	○	○	○	○	○	○	○	○	
	Least command increment 0.01μm (10nm)	△	△	△	△	—	—	—	—	—	—	
	Least command increment 0.001μm (1nm)	△	△	△	△	—	—	—	—	—	—	
2	Least control increment											
	Least control increment 0.01μm (10nm)	○	○	○	○	○	○	○	○	○	○	
	Least control increment 0.001μm (1nm)	○	○	○	○	○	○	○	○	○	○	
3	Indexing increment	○	○	○	○	○	○	○	○	○	○	
2 Unit system												
1	Inch / Metric changeover	○	○	○	○	○	○	○	○	○	○	
2	Input command increment tenfold	—	—	—	—	—	—	—	—	—	—	
3 Program format												
1	Program format											
1	Format 1 for Lathe (G Code List 2, 3)	○	○	○	○	○	○	○	○	○	○	
2	Format 2 for Lathe (G Code List 4, 5)	○	○	○	○	○	○	○	○	○	○	
3	Special format for lathe (G Code List 6, 7)	○	○	○	○	○	○	○	○	○	○	
4	Format 1 for Machining center	—	—	—	—	—	—	—	—	—	—	
5	Format 2 for Machining center (M2 format)	—	—	—	—	—	—	—	—	—	—	
6	MITSUBISHI CNC special format	○	○	○	○	○	○	○	○	○	○	
2	Program format switch	△	△	△	△	—	—	—	—	—	—	
4 Command value												
1	Decimal point input type 1, II	○	○	○	○	○	○	○	○	○	○	
2	Absolute / Incremental command	○	○	○	○	○	○	○	○	○	○	

M800/M80/E80/C80 SERIES SPECIFICATIONS LIST

M800/M80/E80/C80 SERIES SPECIFICATIONS LIST

○Standard △Optional □Selection Specifications of separated-type display are classified with "Windows-based" and non-Windows-based

[M800/M80/E80]S/W ver.F2 [C80]S/W ver.B7

class		Lathe system									
		M800W		M800S		M80W	M80		E80		C80
		M850W	M830W	M850S	M830S	—	M80 TypeA	M80 TypeB	E80 TypeA	E80 TypeB	—
3	Diameter / Radius designation	○	○	○	○	○	○	○	○	○	○
4	Diameter / Radius designation switch	○	○	○	○	○	○	○	○	○	—
3 Positioning / Interpolation											
1 Positioning											
1	Positioning	○	○	○	○	○	○	○	○	○	○
2	Unidirectional positioning	—	—	—	—	—	—	—	—	—	—
2 Linear / Circular interpolation											
1	Linear interpolation	○	○	○	○	○	○	○	○	○	○
2	Circular interpolation (Center / Radius designation)	○	○	○	○	○	○	○	○	○	○
3	Helical interpolation	○	○	○	○	○	○	○	○	○	○
4	Spiral / Conical interpolation	—	—	—	—	—	—	—	—	—	—
5	Cylindrical interpolation	△	△	△	△	○	○	○	○	○	△
6	Polar coordinate interpolation	△	△	△	△	○	○	○	○	○	△
7	Milling interpolation	△	△	△	△	○	○	○	○	○	△
8	Hypothetical axis interpolation	—	—	—	—	—	—	—	—	—	—
3 Curve interpolation											
1	Involute interpolation	—	—	—	—	—	—	—	—	—	—
2	Exponential interpolation	△	△	△	△	—	—	—	—	—	—
3	Spline interpolation (G05.1Q2 / G61.2)	—	—	—	—	—	—	—	—	—	—
4	NURBS interpolation	—	—	—	—	—	—	—	—	—	—
5	3-dimensional circular interpolation	—	—	—	—	—	—	—	—	—	—
6	Spline interpolation2 (G61.4)	—	—	—	—	—	—	—	—	—	—
4 Feed											
1 Feedrate											
1	Rapid traverse rate (m / min)	1000	1000	1000	1000	1000	1000	1000	1000	1000	1000
2	Cutting feedrate (m / min)	1000	1000	1000	1000	1000	1000	1000	1000	1000	1000
3	Manual feedrate (m / min)	1000	1000	1000	1000	1000	1000	1000	1000	1000	1000
4	Rotary axis command speed tenfold	○	○	○	○	○	○	○	○	○	○
2 Feedrate input methods											
1	Feed per minute (Asynchronous feed)	○	○	○	○	○	○	○	○	○	○
2	Feed per revolution (Synchronous feed)	○	○	○	○	○	○	○	○	○	○
3	Inverse time feed	—	—	—	—	—	—	—	—	—	—
4	F 1-digit feed	○	○	○	○	○	○	○	○	○	○
5	Manual speed command	△	△	△	△	○	○	○	○	○	△
7	G00 feedrate designation (F command)	△	△	△	△	○	○	—	—	—	△
8	Selection of axis (axes) for feedrate command	—	—	—	—	—	—	—	—	—	—
3 Override											
1	Rapid traverse override	○	○	○	○	○	○	○	○	○	○
2	Cutting feed override	○	○	○	○	○	○	○	○	○	○
3	2nd cutting feed override	○	○	○	○	○	○	○	○	○	○
4	Override cancel	○	○	○	○	○	○	○	○	○	○

Machining center system										General explanation	
M800W		M800S		M80W	M80		E80		C80		
M850W	M830W	M850S	M830S	—	M80 TypeA	M80 TypeB	E80 TypeA	E80 TypeB	—		
—	—	—	—	—	—	—	—	—	—	—	The designation method of an axis command value can be changed over with parameters between the radius designation or diameter designation. When the diameter designation is selected, the scale of the length of the selected axis is doubled. (moves only half (1/2) the commanded amount)
○	○	○	○	—	—	—	—	—	—	—	Diameter/Radius designation switch function enables you to switch the diameter/radius designation of each axis using a G code at your desired timing.
○	○	○	○	○	○	○	○	○	○	○	This function carries out positioning at high speed using a rapid traverse rate with the travel command value given in the program.
△	△	△	△	○	○	○	○	○	○	△	The G code command always moves the tool to the final position in the direction determined by parameters.
○	○	○	○	○	○	○	○	○	○	○	Linear interpolation is a function that moves a tool linearly by the travel command value supplied in the program at the cutting feedrate designated by the F code.
○	○	○	○	○	○	○	○	○	○	○	This function moves a tool along a circular arc on the plane selected by the travel command value supplied in the program.
○	○	○	○	○	○	○	○	○	○	○	With this function, any two of three axes intersecting orthogonally are made to perform circular interpolation while the third axis performs linear interpolation in synchronization with the arc rotation. This control can be exercised to machine large-diameter screws or 3-dimensional cams.
△	△	△	△	○	○	—	—	—	—	△	This function interpolates arcs where the start point and end point are not on the circumference of the same circle into spiral shapes.
△	△	△	△	○	○	○	—	—	—	△	This function transfers the shape that is on the cylinder's side surface (shape yielded by the cylindrical coordinate system) onto a plane, and when the transferred shape is designated in the program in the form of plane coordinates, the shape is converted into a movement along the linear and rotary axes of the original cylinder coordinates, and the contours are controlled by means of the CNC unit during machining.
△	△	△	△	—	—	—	—	—	—	△	This function converts the commands programmed by the orthogonal coordinate axes into linear axis movements (tool movements) and rotary axis movements (workpiece rotation) to control the contours. It is useful for cutting linear cutouts on the outside diameter of the workpiece, grinding cam shafts, etc.
—	—	—	—	—	—	—	—	—	—	—	When a lathe with linear axes (X, Z axes) and rotary axis (C axis) serving as the control axis is to perform milling at a workpiece end face or in the longitudinal direction of the workpiece, this function uses the hypothetical axis Y, which is at right angles to both the X and Z axes, to enable the milling shape to be programmed as the X, Y and Z orthogonal coordinate system commands.
△	△	△	△	—	—	—	—	—	—	—	This function sets one of the axes of the helical interpolation or spiral interpolation, including a linear axis, as a hypothetical axis (axis with no actual movement), and performs pulse distribution. This enables SIN or COS interpolation, which corresponds to the side view (view from the hypothetical axis) of the helical interpolation or spiral interpolation.
△	△	△	△	○	○	—	—	—	—	—	Tools can be moved along the involute curve. This function can also move a tool helically (spirally) while moving the tool along the involute curve. This can be used for scroll machining of involute gears or compressors, and smooth accurate machining can be performed without stepping of path from the command by fine segment or without acceleration/deceleration by segment length.
△	△	△	△	—	—	—	—	—	—	—	With this function, the rotary axis movement is changed into exponential functions vis-a-vis the linear axis movements.
△	△	△	△	○	○	—	—	—	—	△	This function automatically generates spline curves that smoothly pass through rows of dots designated by a fine-segment machining program, and performs interpolation for the paths along the curves. This enables high-speed and high-accuracy machining.
△	△	△	△	—	—	—	—	—	—	—	This function realizes NURBS curve machining by commanding NURBS curve parameters (number of stages, weight, knot, control point). The path does not need to be replaced with fine segments.
△	△	△	△	○	○	—	—	—	—	—	An arc shape determined by three points (start point, intermediate point, end point) designated in the three-dimensional space can be machined.
△	△	△	△	○	○	—	—	—	—	△	This function automatically generates curves that smoothly pass in the tolerance error range, and moves on the paths along the curves. This enables smooth machining.
1000	1000	1000	1000	1000	1000	1000	1000	1000	1000	1000	The rapid traverse rate can be set independently for each axis using parameters.
1000	1000	1000	1000	1000	1000	1000	1000	1000	1000	1000	This function specifies the feedrate of the cutting commands, and gives a command for a feed amount per spindle rotation or feed amount per minute.
1000	1000	1000	1000	1000	1000	1000	1000	1000	1000	1000	The manual feedrates are designated as the feedrate in jog mode or incremental feed mode for manual operation and the feedrate during dry run ON for automatic operation. The manual feedrates are set using external signals.
○	○	○	○	○	○	○	○	○	○	○	This function multiplies the rotary axis' command speed by ten during initial inching.
○	○	○	○	○	○	○	○	○	○	○	By issuing a G command, the command from the block is issued directly with a numerical value following F as the feedrate per minute (mm / min or inch / min).
△	△	△	△	○	○	○	○	○	○	△	By issuing a G command, the command from the block is issued directly with a numerical value following F as the feedrate per spindle revolution (mm / rev or inch / rev).
△	△	△	△	○	○	—	—	—	—	△	This function can issue one block of machining time (inverse) commands in F commands, in place of normal feed commands. This enables the machining speed on the cutting surface to be constantly controlled and prevents the loss of accuracy, even if radius compensation is applied to the machining program that expresses the free curve surface with fine segment lines.
○	○	○	○	○	○	○	○	○	○	○	The feedrate registered by parameter in advance can be assigned by designating a single digit, following address F.
△	△	△	△	○	○	○	○	—	—	△	By enabling a manual speed command and selecting either handle feed or jog (manual) feed in the memory or MDI mode, automatic operation can be carried out at this feedrate.
△	△	△	△	○	○	—	—	—	—	△	Feedrates can be specified for G00 (positioning command). The speed of tool exchange, axis movement of gantry, etc. can be specified with the machining program so that the mechanical vibration can be suppressed.
△	△	△	△	—	—	—	—	—	—	—	This function enables designation of the feedrate of a specific axis (with the command F).
○	○	○	○	○	○	○	○	○	○	○	Override can be applied to manual or automatic rapid traverse using the external input signal.
○	○	○	○	○	○	○	○	○	○	○	Override can be applied to the feedrate command designated in the machining program using the external input signal.
○	○	○	○	○	○	○	○	○	○	○	Override can be further applied as a second-stage override to the feedrate after the cutting feed override has been applied.
○	○	○	○	○	○	○	○	○	○	○	By turning on the override cancel external signal, the override is automatically set to 100% for the cutting feed during the automatic operation mode (tape, memory and MDI).

M800/M80/E80/C80 SERIES SPECIFICATIONS LIST

M800/M80/E80/C80 SERIES SPECIFICATIONS LIST

○Standard △Optional □Selection Specifications of separated-type display are classified with "Windows-based" and non-Windows-based

[M800/M80/E80]S/W ver.F2 [C80]S/W ver.B7

class	Lathe system										C80	General explanation	
	M800W		M800S		M80W	M80		E80		—			
	M850W	M830W	M850S	M830S	—	M80 TypeA	M80 TypeB	E80 TypeA	E80 TypeB				
4 Acceleration / Deceleration													
1	Automatic acceleration / deceleration after interpolation	○	○	○	○	○	○	○	○	○	○	○	Acceleration / deceleration is automatically applied to all commands. The acceleration / deceleration patterns can be selected using a parameter from the following types: linear acceleration/deceleration, soft acceleration / deceleration, exponent function acceleration / deceleration and exponent function acceleration / linear deceleration.
2	Rapid traverse constant-gradient acceleration / deceleration	○	○	○	○	○	○	○	○	○	○	○	This function performs acceleration / deceleration at a constant-gradient during linear acceleration / deceleration by the rapid traverse command or the linear interpolation command. Compared to the method of acceleration / deceleration after interpolation, the constant-gradient acceleration / deceleration method enables improved cycle time.
3	Rapid traverse constant-gradient multi-step acceleration / deceleration	—	—	—	—	—	—	—	—	—	—	—	This function carries out the acceleration / deceleration according to the torque characteristic of the motor in the rapid traverse mode during automatic operation. (This function is not available in manual operation.) The rapid traverse constant-gradient multi-step acceleration / deceleration method makes for improved cycle time because the positioning time is shortened by using the motor ability to the maximum.
5 Thread cutting													
1	Thread cutting (Lead / Thread number designation)	○	○	○	○	○	○	○	○	○	○	○	Thread cutting with a designated lead can be performed. Inch threads are cut by designating the number of threads per inch with the E address.
2	Variable lead thread cutting	○	○	○	○	○	○	○	○	○	○	○	By commanding the lead increment/decrement amount per thread rotation, variable lead thread cutting can be performed.
3	Synchronous tapping												* With digital I/F spindle
1	Synchronous tapping cycle	○	○	○	○	○	○	○	○	○	○	○	This function performs tapping through synchronized control of the spindle and servo axis. This eliminates the need for floating taps and enables tapping to be conducted at a highly accurate tapping depth.
2	Pecking tapping cycle	△	△	△	△	○	○	○	○	○	○	△	The load applied to the tool can be reduced by designating the depth of cut per pass and cutting the workpiece to the hole bottom with a multiple number of passes.
3	Deep-hole tapping cycle	△	△	△	△	○	○	○	○	○	○	△	In the deep-hole tapping, the load applied to the tool can be reduced by designating the depth of cut per pass and cutting the workpiece to the hole bottom with a multiple number of passes.
4	Multiple spindle synchronous tapping	—	—	—	—	—	—	—	—	—	—	△	This function enables two or more spindles to perform synchronous tapping at a time, thereby improving the tapping efficiency.
5	Synchronous tapping with analog I/F spindle	○	○	○	○	○	○	○	○	○	○	—	This function performs tapping using the analog-connected spindle. A dedicated inverter with position controller is required.
4	Chamfering	○	○	○	○	○	○	○	○	○	○	○	Chamfering can be enabled during the thread cutting cycle by using external signals.
6	Circular thread cutting	△	△	△	△	○	○	—	—	—	—	—	Circular thread in which the lead is in longitudinal direction can be cut.
8	High-speed synchronous tapping (OMR-DD)	○	○	○	○	○	○	○	—	—	○	○	The servo axis directly detects and compensates the spindle's delay in tracking by using the communication between drive units over the high-speed optical servo network. By minimizing the synchronization error, the accuracy of the synchronous tapping is increased.
10	Thread recutting	△	△	△	△	○	○	—	—	—	—	△	The function stores a thread groove position and compensates a start position of spindle thread cutting automatically so that the tool can pass along the memorized position of the thread groove at the thread cutting execution.
11	Thread cutting override	△	△	△	△	○	○	—	—	—	—	△	The thread cutting feedrate can be changed by changing the spindle override depending on rough cutting, finish machining, etc.
12	Variable feed thread cutting	△	△	△	△	○	○	—	—	—	—	△	This function changes the cutting feedrate by the spindle override at the time of the thread cutting. The machining condition during thread cutting can be changed.
13	Thread cutting time constant switch	○	○	○	○	○	○	○	○	○	○	—	"Thread cutting time constant" can be applied to the acceleration/deceleration time constant of the NC control axis during the thread cutting.
6 Manual feed													
1	Manual rapid traverse	○	○	○	○	○	○	○	○	○	○	○	The tool can be moved at the rapid traverse rate for each axis separately. Override can also be applied to the rapid traverse rate by means of the rapid traverse override function.
2	Jog feed	○	○	○	○	○	○	○	○	○	○	○	The tool can be moved in the axis direction (+ or -) in which the machine is to be moved at the per-minute feedrate.
3	Incremental feed	○	○	○	○	○	○	○	○	○	○	○	The tool can be moved for the designated amount (incremental amount) in the axis direction each time the jog switch is pressed.
4	Handle feed	○	○	○	○	○	○	○	○	○	○	○	The machine can be moved in very small amounts by rotating the manual pulse generator.
5	Manual feedrate B	○	○	○	○	○	○	○	○	○	○	○	Manual feedrate B is a function that sets an arbitrary axis feedrate from the user PLC separately from the manual feedrate.
6	Manual feedrate B surface speed control	—	—	—	—	—	—	—	—	—	—	—	When machining with the manual feedrate B function by moving the orthogonal axis while rotating the rotary table, the table rotation speed is controlled according to the distance from the rotation center.
8	Manual speed clamp	○	○	○	○	○	○	○	○	○	○	○	The maximum speed for manual feed can be switched to the rapid traverse rate or the manual feed clamp speed.
7 Dwell													
1	Dwell (Time-based designation)	○	○	○	○	○	○	○	○	○	○	○	The G code command temporarily stops machine movements and sets the machine in the stand-by status for the time designated in the program.
2	Dwell (Revolution-based designation)	○	○	○	○	○	○	○	○	○	○	○	When G04 is commanded in the synchronous feed mode (G95), the machine waits for the spindle to rotate for the number of the revolutions designated.
5 Program memory / editing													
1 Memory capacity													
1	Memory capacity (number of programs stored)												Machining programs are stored in the NC memory, data server or external memory devices (front SD card, built-in disk of display unit, etc.). (Note) For a multi-part system, the specifications shown here is the total for all part systems.
	230kB [600m] (400 programs)	—	—	—	—	—	—	○	○	—	—	—	* Up to 2000 programs for C80
	500kB [1280m] (1000 programs)	○	○	○	○	○	○	○	○	○	○	○	
	1000kB [2560m] (1000 programs)	△	△	△	△	—	—	—	—	—	—	△*	
	2000kB [5120m] (1000 programs)	△	△	△	△	—	—	—	—	—	—	△*	
2 Editing													
1	Program editing	○	○	○	○	○	○	○	○	○	○	○	This function enables program editing such as correction, deletion and addition.
2	Background editing	○	○	○	○	○	○	○	○	○	○	○	This function enables one machining program to be created or edited while another program is running.
3	Buffer correction	○	○	○	○	○	○	○	○	○	○	○	During automatic operation (including memory, tape, SD card or Data Server (DS) operation) or MDI operation, this function initiates single block stop and enables the next command to be corrected or changed. When a program error has occurred, the function enables the block in which the error occurred to be corrected and operation to be resumed without having to perform NC resetting.
5	Multi-part system simultaneous program editing	○	○	○	○	○	○	○	—	—	—	○	When an operation to open a machining program in the NC memory is performed on the edit screen, machining programs are opened in the right and left areas at the same time; the specified machining program of the displayed part system in the edit area being selected and the machining program of another part system with the same name in the unselected edit area.
6	Special program editing display for synchronization between part systems	△	△	△	△	○	○	—	—	—	—	△	When the left and right edit areas are displaying the same named programs of different part systems stored on the NC memory, the display is switched to the synchronized display of the left- and right- side programs aligned using the timing synchronization symbols.
7	Finish shape view programming	△	△	△	△	○	○	○	○	—	—	—	This function shows the machining shape according to the command at the time the machining program is input. The machining shape can be confirmed easily without performing the automatic operation or the graphic check.

class	Machining center system										C80	General explanation	
	M800W		M800S		M80W	M80		E80		—			
	M850W	M830W	M850S	M830S	—	M80 TypeA	M80 TypeB	E80 TypeA	E80 TypeB				
4 Acceleration / Deceleration													
1	Automatic acceleration / deceleration after interpolation	○	○	○	○	○	○	○	○	○	○	○	Acceleration / deceleration is automatically applied to all commands. The acceleration / deceleration patterns can be selected using a parameter from the following types: linear acceleration/deceleration, soft acceleration / deceleration, exponent function acceleration / deceleration and exponent function acceleration / linear deceleration.
2	Rapid traverse constant-gradient acceleration / deceleration	○	○	○	○	○	○	○	○	○	○	○	This function performs acceleration / deceleration at a constant-gradient during linear acceleration / deceleration by the rapid traverse command or the linear interpolation command. Compared to the method of acceleration / deceleration after interpolation, the constant-gradient acceleration / deceleration method enables improved cycle time.
3	Rapid traverse constant-gradient multi-step acceleration / deceleration	△	△	△	△	○	○	○	—	—	—	△	This function carries out the acceleration / deceleration according to the torque characteristic of the motor in the rapid traverse mode during automatic operation. (This function is not available in manual operation.) The rapid traverse constant-gradient multi-step acceleration / deceleration method makes for improved cycle time because the positioning time is shortened by using the motor ability to the maximum.
5 Thread cutting													
1	Thread cutting (Lead / Thread number designation)	△	△	△	△	○	○	○	○	○	○	△	Thread cutting with a designated lead can be performed. Inch threads are cut by designating the number of threads per inch with the E address.
2	Variable lead thread cutting	—	—	—	—	—	—	—	—	—	—	—	By commanding the lead increment/decrement amount per thread rotation, variable lead thread cutting can be performed.
3	Synchronous tapping												* With digital I/F spindle
1	Synchronous tapping cycle	○	○	○	○	○	○	○	○	○	○	○	This function performs tapping through synchronized control of the spindle and servo axis. This eliminates the need for floating taps and enables tapping to be conducted at a highly accurate tapping depth.
2	Pecking tapping cycle	△	△	△	△	○	○	○	○	○	○	△	The load applied to the tool can be reduced by designating the depth of cut per pass and cutting the workpiece to the hole bottom with a multiple number of passes.
3	Deep-hole tapping cycle	△	△	△	△	○	○	○	○	○	○	△	In the deep-hole tapping, the load applied to the tool can be reduced by designating the depth of cut per pass and cutting the workpiece to the hole bottom with a multiple number of passes.
4	Multiple spindle synchronous tapping	—	—	—	—	—	—	—	—	—	—	△	This function enables two or more spindles to perform synchronous tapping at a time, thereby improving the tapping efficiency.
5	Synchronous tapping with analog I/F spindle	○	○	○	○	○	○	○	○	○	○	—	This function performs tapping using the analog-connected spindle. A dedicated inverter with position controller is required.
4	Chamfering	○	○	○	○	○	○	○	○	○	○	○	Chamfering can be enabled during the thread cutting cycle by using external signals.
6	Circular thread cutting	△	△	△	△	○	○	—	—	—	—	—	Circular thread in which the lead is in longitudinal direction can be cut.
8	High-speed synchronous tapping (OMR-DD)	○	○	○	○	○	○	○	—	—	○	○	The servo axis directly detects and compensates the spindle's delay in tracking by using the communication between drive units over the high-speed optical servo network. By minimizing the synchronization error, the accuracy of the synchronous tapping is increased.
10	Thread recutting	△	△	△	△	○	○	—	—	—	—	△	The function stores a thread groove position and compensates a start position of spindle thread cutting automatically so that the tool can pass along the memorized position of the thread groove at the thread cutting execution.
11	Thread cutting override	△	△	△	△	○	○	—	—	—	—	△	The thread cutting feedrate can be changed by changing the spindle override depending on rough cutting, finish machining, etc.
12	Variable feed thread cutting	△	△	△	△	○	○	—	—	—	—	△	This function changes the cutting feedrate by the spindle override at the time of the thread cutting. The machining condition during thread cutting can be changed.
13	Thread cutting time constant switch	○	○	○	○	○	○	○	○	○	○	—	"Thread cutting time constant" can be applied to the acceleration/deceleration time constant of the NC control axis during the thread cutting.
6 Manual feed													
1	Manual rapid traverse	○	○	○	○	○	○	○	○	○	○	○	The tool can be moved at the rapid traverse rate for each axis separately. Override can also be applied to the rapid traverse rate by means of the rapid traverse override function.
2	Jog feed	○	○	○	○	○	○	○	○	○	○	○	The tool can be moved in the axis direction (+ or -) in which the machine is to be moved at the per-minute feedrate.
3	Incremental feed	○	○	○	○	○	○	○	○	○	○	○	The tool can be moved for the designated amount (incremental amount) in the axis direction each time the jog switch is pressed.
4	Handle feed	○	○	○	○	○	○	○	○	○	○	○	The machine can be moved in very small amounts by rotating the manual pulse generator.
5	Manual feedrate B	○	○	○	○	○	○	○	○	○	○	○	Manual feedrate B is a function that sets an arbitrary axis feedrate from the user PLC separately from the manual feedrate.
6	Manual feedrate B surface speed control	△	△	△	△	—	—	—	—	—	—	—	When machining with the manual feedrate B function by moving the orthogonal axis while rotating the rotary table, the table rotation speed is controlled according to the distance from the rotation center.
8	Manual speed clamp	○	○	○	○	○	○	○	○	○	○	○	The maximum speed for manual feed can be switched to the rapid traverse rate or the manual feed clamp speed.
7 Dwell													
1	Dwell (Time-based designation)	○	○	○	○	○	○	○	○	○	○	○	The G code command temporarily stops machine movements and sets the machine in the stand-by status for the time designated in the program.
2	Dwell (Revolution-based designation)	○	○	○	○	○	○	○	○	○	○	○	When G04 is commanded in the synchronous feed mode (G95), the machine waits for the spindle to rotate for the number of the revolutions designated.
5 Program memory / editing													
1 Memory capacity													
1	Memory capacity (number of programs stored)												Machining programs are stored in the NC memory, data server or external memory devices (front SD card, built-in disk of display unit, etc.). (Note) For a multi-part system, the specifications shown here is the total for all part systems.
	230kB [600m] (400 programs)	—	—	—	—	—	—	○	○	—	—	—	* Up to 2000 programs for C80
	500kB [1280m] (1000 programs)	○	○	○	○	○	○	○	○	○	○	○	
	1000kB [2560m] (1000 programs)	△	△	△	△	—	—	—	—	—	—	△*	
	2000kB [5120m] (1000 programs)	△	△	△	△	—	—	—	—	—	—	△*	
2 Editing													
1	Program editing	○	○	○	○	○	○	○	○	○	○	○	This function enables program editing such as correction, deletion and addition.
2	Background editing	○	○	○	○	○	○	○	○	○	○	○	This function enables one machining program to be created or edited while another program is running.
3	Buffer correction	○	○	○	○	○	○	○	○	○	○	○	During automatic operation (including memory, tape, SD card or Data Server (DS) operation) or MDI operation, this function initiates single block stop and enables the next command to be corrected or changed. When a program error has occurred, the function enables the block in which the error occurred to be corrected and operation to be resumed without having to perform NC resetting.
5	Multi-part system simultaneous program editing	○	○	○	○	○	○	○	—	—	—	○	When an operation to open a machining program in the NC memory is performed on the edit screen, machining programs are opened in the right and left areas at the same time; the specified machining program of the displayed part system in the edit area being selected and the machining program of another part system with the same name in the unselected edit area.
6	Special program editing display for synchronization between part systems	△	△	△	△	○	○	—	—	—	—	△	When the left and right edit areas are displaying the same named programs of different part systems stored on the NC memory, the display is switched to the synchronized display of the left- and right- side programs aligned using the timing synchronization symbols.
7	Finish shape view programming	△	△	△	△	○	○	○	○	—	—	—	This function shows the machining shape according to the command at the time the machining program is input. The machining shape can be confirmed easily without performing the automatic operation or the graphic check.

○Standard △Optional □Selection Specifications of separated-type display are classified with "Windows-based" and non-Windows-based

[M800/M80/E80]S/W ver.F2 [C80]S/W ver.B7

class	Lathe system									
	M800W		M800S		M80W	M80		E80		C80
	M850W	M830W	M850S	M830S	—	M80 TypeA	M80 TypeB	E80 TypeA	E80 TypeB	—
6 Operation and display										
1 Structure of operation / display panel										
1	—	—	—	—	—	□	□	○	○	—
2	—	—	□	□	—	□	□	—	—	—
3	—	—	□	□	—	□	□	—	—	—
4	—	—	—	—	□	—	—	—	—	—
5	□	□	—	—	□	—	—	—	—	—
6	□	□	—	—	□	—	—	—	—	—
7	□	□	—	—	□	—	—	—	—	—
8	□	□	—	—	□	—	—	—	—	—
9	□	□	—	—	□	—	—	—	—	—
11	—	—	—	—	—	—	—	—	—	○
2 Operation methods and functions										
1	○	○	○	○	○	○	○	○	○	○
2	○	○	○	○	○	○	○	○	○	○
3	—	—	—	—	—	—	—	—	—	○(GOT)
4	—	—	—	—	—	—	—	—	—	○(GOT)
5	○	○	○	○	○	○	○	—	—	○
6	○	○	○	○	○	○	○	○	○	○
7	○	○	○	○	○	○	○	○	○	○
8	○	○	○	○	○	○	—	—	—	○
9	○	○	○	○	○	○	○	○	○	○(GOT)
10	○	○	○	○	○	○	○	○	○	○
11	○	○	○	○	○	○	○	○	○	○
12	△	△	△	△	—	—	—	—	—	—
14	—/○	—/○	○	○	—/○	○	○	○	○	○(GOT)
15	○	○	○	○	○	○	○	○	○	○
16	○/—	○/—	—	—	○/—	—	—	—	—	—
17	○	○	○	○	○	○	○	○	○	—
18	○	○	○	○	○	○	○	○	○	—
19	○	○	○	○	○	○	○	○	○	○
20	—/○	—/○	△	△	—/○	○	○	—	—	—
21	—/△	—/△	△	△	—/○	○	○	—	—	—
3 Display methods and contents										
1	○	○	○	○	○	○	○	○	○	○
2	○	○	○	○	○	○	○	○	○	○
3	○	○	○	○	○	○	○	○	○	○
4	○	○	○	○	○	○	○	○	○	○
5	○	○	○	○	○	○	○	○	○	○
6	○	○	○	○	○	○	○	○	○	○
7	○	○	○	○	○	○	○	○	○	○
8	○/—	○/—	—	—	○/—	—	—	—	—	—
9	○	○	○	○	○	○	○	○	○	—

General explanation	Machining center system									
	M800W		M800S		M80W	M80		E80		C80
	M850W	M830W	M850S	M830S	—	M80 TypeA	M80 TypeB	E80 TypeA	E80 TypeB	—
The setting and display unit consists of the display unit and the keyboard unit. Refer to "HARDWARE" described later for the details. (Note) Only software keyboard is available and there is no hardware keyboard for the separated-type color touchscreen display (19-type LCD TFT/Windows8 or 19-type horizontal LCD TFT/Windows8).	—	—	—	—	—	□	□	○	○	—
	—	—	□	□	—	□	□	—	—	—
	—	—	□	□	—	□	□	—	—	—
	—	—	—	—	□	—	—	—	—	—
	□	□	—	—	□	—	—	—	—	—
	□	□	—	—	□	—	—	—	—	—
	□	□	—	—	□	—	—	—	—	—
	□	□	—	—	□	—	—	—	—	—
	□	□	—	—	□	—	—	—	—	—
	□	□	—	—	□	—	—	—	—	—
	□	□	—	—	□	—	—	—	—	—
Select a GOT in its lineup. For details, refer to catalogs "GOT2000 series".	—	—	—	—	—	—	—	—	—	○
In addition to the method of directly inputting numeric data, a method to input the operation results using four basic arithmetic operators and function symbols can be used for specific data settings.	○	○	○	○	○	○	○	○	○	○
When setting the data, the absolute/incremental setting can be selected from the menu.	○	○	○	○	○	○	○	○	○	○
Using an Ethernet hub, one CNC module can be connected to and switched between up to eight displays. (Note that the max. number of connectable displays is limited depending on the machine operation panel specifications.)	—	—	—	—	—	—	—	—	—	○(GOT)
Using an Ethernet hub, one display can be connected to and switched between up to 64 CNC modules. (Note that the max. number of connectable displays is limited depending on the machine operation panel specifications.)	—	—	—	—	—	—	—	—	—	○(GOT)
The part system displayed on the screen can be changed.	○	○	○	○	○	○	—	—	—	○
The menu list function displays the menu configuration of each screen as a list, making it possible to directly select the menu for other screens.	○	○	○	○	○	○	○	○	○	○
The screen display changes when the screen mode selection switch is changed.	○	○	○	○	○	○	○	○	○	○
The screen display changes with the signal from PLC.	○	○	○	○	○	○	—	—	—	○
The screen saver function protects the display unit by turning the backlight OFF after the length of time specified in a parameter.	○	○	○	○	○	○	○	○	○	○(GOT)
This function displays the details of the parameters or the operation methods according to the state of the screen currently displayed.	○	○	○	○	○	○	○	○	○	○
Guidance is displayed for the alarm currently issued.	○	○	○	○	○	○	○	○	○	○
If an illegal input is found in the decimal point after the current cursor position, the cursor will move to that position, and a warning message will appear.	△	△	△	△	—	—	—	—	—	—
This function allows to output a bitmap file of a screen displayed on the setting and display unit to USB memory or SD card.	—/○	—/○	○	○	—/○	○	○	○	○	○(GOT)
This function allows to change the display order of the main menu in the "Monitor", "Setup" and "Edit" screens, and to change display / non-display selection.	○	○	○	○	○	○	○	○	○	○
This function supports to restore the connection when the network connection fails between the display unit and the control unit.	○/—	○/—	—	—	○/—	—	—	—	—	—
This function can set or change the user backed up area of the PLC device from the NC screen.	○	○	○	○	○	○	○	○	○	—
This function can set or change the SRAM open area for machine tool builders from the NC screen.	○	○	○	○	○	○	○	○	○	—
Menu items on the "Monitor", "Setup" and "Edit" screens (of MITSUBISHI standard format) can be moved within a screen or hidden as desired. The custom screen menu items added by machine tool builders, on the contrary, cannot be moved or hidden.	○	○	○	○	○	○	○	○	○	○
This enables the operation of the external personal computer on the screen of NC with UltraVNC Server embedded.	—/○	—/○	△	△	—/○	○	○	—	—	—
This function enables status confirmation and remote operation by displaying the NC screen display on the external computer/tablet type computer.	—/△	—/△	△	△	—/○	○	○	—	—	—
The status of the program currently being executed is indicated.	○	○	○	○	○	○	○	○	○	○
The clock is built in, and the date (year, month, date) and time (hour, minute, second) are displayed.	○	○	○	○	○	○	○	○	○	○
Various information related to operation, such as the axis counter, speed display and MSTB command are displayed.	○	○	○	○	○	○	○	○	○	○
Tool/workpiece related settings, user parameter settings, MDI editing, counter setting, manual numeric command issuing and pallet program registration (option) can be carried out.	○	○	○	○	○	○	○	○	○	○
Machining program editing (addition, deletion, change) and checking, simple program creation, and machining program input / output can be carried out.	○	○	○	○	○	○	○	○	○	○
The following operations related to the CNC diagnosis can be carried out. (1) Display the hardware and software configuration. (2) Display the CNC options. (3) Diagnose the PLC interface. (4) Display the drive unit information. (5) Display the alarm message / alarm history list etc.	○	○	○	○	○	○	○	○	○	○
Parameter setting and display, and NC data input/output, etc., can be carried out.	○	○	○	○	○	○	○	○	○	○
19-type vertical display unit has the expansion applications that display the machine status, software keyboard, etc. in the lower half of the screen in no linkage with the upper half.	○/—	○/—	—	—	○/—	—	—	—	—	—
Home screen is able to display the machine status (including spindle loads and positions of linear and rotary axes) which can be monitored by an operator. Also, each application can be called by pressing the application button on the home screen.	○	○	○	○	○	○	○	○	○	—

M800/M80/E80/C80 SERIES SPECIFICATIONS LIST

M800/M80/E80/C80 SERIES SPECIFICATIONS LIST

○Standard △Optional □Selection Specifications of separated-type display are classified with "Windows-based" and non-Windows-based

[M800/M80/E80]S/W ver.F2 [C80]S/W ver.B7

class	Lathe system										C80	General explanation	
	M800W		M800S		M80W	M80		E80		—			
	M850W	M830W	M850S	M830S	—	M80 TypeA	M80 TypeB	E80 TypeA	E80 TypeB				
10 Additional languages													
1 Japanese	○	○	○	○	○	○	○	○	○	○	○	○	
2 English	○	○	○	○	○	○	○	○	○	○	○	○	
3 German	○	○	○	○	○	○	○	○	○	○	○	○	
4 Italian	○	○	○	○	○	○	○	○	○	○	○	○	
5 French	○	○	○	○	○	○	○	○	○	○	○	○	
6 Spanish	○	○	○	○	○	○	○	○	○	○	○	○	
7 Chinese													
1 Traditional Chinese characters	○	○	○	○	○	○	○	○	○	○	○	○	
2 Simplified Chinese characters	○	○	○	○	○	○	○	○	○	○	○	○	
8 Korean	○	○	○	○	○	○	○	○	○	○	○	○	
9 Portuguese	○	○	○	○	○	○	○	○	○	○	○	○	
10 Hungarian	○	○	○	○	○	○	○	○	○	○	○	○	
11 Dutch	○	○	○	○	○	○	○	○	○	○	○	○	
12 Swedish	○	○	○	○	○	○	○	○	○	○	○	○	
13 Turkish	○	○	○	○	○	○	○	○	○	○	○	○	
14 Polish	○	○	○	○	○	○	○	○	○	○	○	○	
15 Russian	○	○	○	○	○	○	○	○	○	○	○	○	
16 Czech	○	○	○	○	○	○	○	○	○	○	○	○	
17 Indonesian	○	○	○	○	○	○	○	○	○	○	○	○	
7 Input / Output functions and devices													
1 Input / Output data													
1 Machining program input / output	○	○	○	○	○	○	○	○	○	○	○	○	
2 Tool offset data input / output	○	○	○	○	○	○	○	○	○	○	○	○	
3 Common variable input / output	○	○	○	○	○	○	○	○	○	○	○	○	
4 Parameter input / output	○	○	○	○	○	○	○	○	○	○	○	○	
5 History data output	○	○	○	○	○	○	○	○	○	○	○	○	
7 System configuration data output	○	○	○	○	○	○	○	○	○	○	○	○	
2 Input / Output I/F													
1 RS-232C I/F	○	○	○	○	○	○	○	○	○	○	○	○	
2 SD card I/F													
1 Control unit-side SD card I/F [up to 32GB]	○	○	○	○	○	○	○	○	○	○	○	○	
2 Front-side SD card I/F [up to 32GB]	○/—	○/—	○	○	○/—	○	○	○	○	○	○	○	
3 Ethernet I/F	○	○	○	○	○	○	○	○	○	○	○	○	○(GOT)
4 Display unit-side data server I/F	○	○	○	○	○	○	○	○	○	○	○	○	
5 Front-side USB memory I/F [up to 32GB]	○	○	○	○	○	○	○	○	○	○	○	○	
6 USB I/F (GOT front-side USB I/F)	—	—	—	—	—	—	—	—	—	—	—	○	
7 SD I/F (GOT back-side SD card I/F)	—	—	—	—	—	—	—	—	—	—	—	○	
3 Computer link													
1 Computer link B	△	△	△	△	○	○	○	—	—	—	—	—	
4 Others													
1 Handy terminal connection	○	○	○	○	○	○	○	—	—	—	—	—	
3 IP filter setting	○	○	○	○	○	○	○	○	○	○	○	○	
8 Spindle, Tool and Miscellaneous functions													
1 Spindle functions (S)													
1 Spindle control functions													
1 Spindle digital I/F	○	○	○	○	○	○	○	○	○	○	○	○	
2 Spindle analog I/F	○	○	○	○	○	○	○	○	○	○	○	△ (MELSEC)	
3 Coil switch	○	○	○	○	○	○	○	○	○	○	○	○	
4 Automatic coil switch	○	○	○	○	○	○	○	○	○	○	○	○	
5 Encoder input I/F	□	□	○	○	□	○	○	○	○	○	○	—	
6 Spindle-mode servo motor control	△	△	△	△	○	○	○	○	○	○	○	△	
7 Spindle-mode rotary axis control	—	—	—	—	—	—	—	—	—	—	—	—	
8 Turret gear change control	△	△	△	△	○	○	○	○	—	—	—	—	
9 Spindle control with pulse train output	—	—	—	—	—	○	○	○	○	○	○	—	
2 S code output	○	○	○	○	○	○	○	○	○	○	○	○	
3 Constant surface speed control	○	○	○	○	○	○	○	○	○	○	○	○	
4 Spindle override	○	○	○	○	○	○	○	○	○	○	○	○	

class	Machining center system										C80	General explanation	
	M800W		M800S		M80W	M80		E80		—			
	M850W	M830W	M850S	M830S	—	M80 TypeA	M80 TypeB	E80 TypeA	E80 TypeB				
10 Additional languages													
1 Japanese	○	○	○	○	○	○	○	○	○	○	○	○	
2 English	○	○	○	○	○	○	○	○	○	○	○	○	
3 German	○	○	○	○	○	○	○	○	○	○	○	○	
4 Italian	○	○	○	○	○	○	○	○	○	○	○	○	
5 French	○	○	○	○	○	○	○	○	○	○	○	○	
6 Spanish	○	○	○	○	○	○	○	○	○	○	○	○	
7 Chinese													
1 Traditional Chinese characters	○	○	○	○	○	○	○	○	○	○	○	○	
2 Simplified Chinese characters	○	○	○	○	○	○	○	○	○	○	○	○	
8 Korean	○	○	○	○	○	○	○	○	○	○	○	○	
9 Portuguese	○	○	○	○	○	○	○	○	○	○	○	○	
10 Hungarian	○	○	○	○	○	○	○	○	○	○	○	○	
11 Dutch	○	○	○	○	○	○	○	○	○	○	○	○	
12 Swedish	○	○	○	○	○	○	○	○	○	○	○	○	
13 Turkish	○	○	○	○	○	○	○	○	○	○	○	○	
14 Polish	○	○	○	○	○	○	○	○	○	○	○	○	
15 Russian	○	○	○	○	○	○	○	○	○	○	○	○	
16 Czech	○	○	○	○	○	○	○	○	○	○	○	○	
17 Indonesian	○	○	○	○	○	○	○	○	○	○	○	○	
7 Input / Output functions and devices													
1 Input / Output data													
1 Machining program input / output	○	○	○	○	○	○	○	○	○	○	○	○	
2 Tool offset data input / output	○	○	○	○	○	○	○	○	○	○	○	○	
3 Common variable input / output	○	○	○	○	○	○	○	○	○	○	○	○	
4 Parameter input / output	○	○	○	○	○	○	○	○	○	○	○	○	
5 History data output	○	○	○	○	○	○	○	○	○	○	○	○	
7 System configuration data output	○	○	○	○	○	○	○	○	○	○	○	○	
2 Input / Output I/F													
1 RS-232C I/F	○	○	○	○	○	○	○	○	○	○	○	○	
2 SD card I/F													
1 Control unit-side SD card I/F [up to 32GB]	○	○	○	○	○	○	○	○	○	○	○	○	
2 Front-side SD card I/F [up to 32GB]	○/—	○/—	○	○	○/—	○	○	○	○	○	○	○	
3 Ethernet I/F	○	○	○	○	○	○	○	○	○	○	○	○	○(GOT)
4 Display unit-side data server I/F	○	○	○	○	○	○	○	○	○	○	○	○	
5 Front-side USB memory I/F [up to 32GB]	○	○	○	○	○	○	○	○	○	○	○	○	
6 USB I/F (GOT front-side USB I/F)	—	—	—	—	—	—	—	—	—	—	—	○	
7 SD I/F (GOT back-side SD card I/F)	—	—	—	—	—	—	—	—	—	—	—	○	
3 Computer link													
1 Computer link B	△	△	△	△	○	○	○	—	—	—	—	—	
4 Others													
1 Handy terminal connection	○	○	○	○	○	○	○	—	—	—	—	—	
3 IP filter setting	○	○	○	○	○	○	○	○	○	○	○	○	
8 Spindle, Tool and Miscellaneous functions													
1 Spindle functions (S)													
1 Spindle control functions													
1 Spindle digital I/F	○	○	○	○	○	○	○	○	○	○	○	○	
2 Spindle analog I/F	○	○	○	○	○	○	○	○	○	○	○	△ (MELSEC)	
3 Coil switch	○	○	○	○	○	○	○	○	○	○	○	○	
4 Automatic coil switch	○	○	○	○	○	○	○	○	○	○	○	○	
5 Encoder input I/F	□	□	○	○	□	○	○	○	○	○	○	—	
6 Spindle-mode servo motor control	△	△	△	△	○	○	○	○	—	—	—	△	
7 Spindle-mode rotary axis control	—	—	—	—	—	—	—	—	—	—	—	—	
8 Turret gear change control	△	△	△	△	○	○	○	○	—	—	—	—	
9 Spindle control with pulse train output	—	—	—	—	—	○	○	○	○	○	○	—	
2 S code output	○	○	○	○	○	○	○	○	○	○	○	○	
3 Constant surface speed control	○	○	○	○	○	○	○	○	○	○	○	○	
4 Spindle override	○	○	○	○	○	○	○	○	○	○	○	○	

○Standard △Optional □Selection Specifications of separated-type display are classified with "Windows-based" and non-Windows-based

[M800/M80/E80]S/W ver.F2 [C80]S/W ver.B7

class	Lathe system										C80	General explanation
	M800W		M800S		M80W	M80		E80		—		
	M850W	M830W	M850S	M830S	—	M80 TypeA	M80 TypeB	E80 TypeA	E80 TypeB			
5	Multiple-spindle control											Multiple-spindle control is a function that controls all the spindles except the first spindle (main spindle) in a machine tool equipped with the second, third and fourth spindles (sub-spindles) in addition to the first spindle.
1	Multiple-spindle control I										○	This function controls the spindles in a machine tool equipped with several spindles.
2	Multiple-spindle control II										○	With this function, commands to the spindle are performed with one S command, and a signal from the PLC determines which spindle is selected.
6	Spindle orientation										○	This function stops the spindle rotation at a certain position.
7	Spindle position control (Spindle / C axis control)											
1	Spindle position control (Spindle / C axis control)										○	This function enables one spindle drive unit to be also used as the C axis (rotary axis) using an external signal.
2	C axis control during Spindle synchronization										△	This control enables C axis positioning while a long workpiece is controlled by front and back spindles that are in synchronization with each other. Under this control, the machine can perform milling at the center of workpiece.
8	Spindle synchronization											
1	Spindle synchronization I										○	In a machine with two or more spindles, this function controls the rotation speed and phase of one selected spindle (synchronized spindle) in synchronization with the rotation of the other selected spindle (basic spindle). There are two methods for giving commands: G code and PLC.
2	Spindle synchronization II										○	This function is used for a machine with a spindle motor to rotate a guide bushing. It synchronizes the guide bushing spindle (G/B spindle) with the spindle motor used as a reference (basic spindle).
3	Guide bushing spindle synchronization										△	
9	Tool spindle synchronization I (Polygon)											
1	Tool spindle synchronization I A (Spindle-Spindle, Polygon)										△	In a machine containing a rotary tool axis and that has a spindle controlled as the workpiece axis, spindle-spindle polygon machining can be carried out by controlling the workpiece axis rotation in synchronization with the rotation of the rotary tool axis.
2	Tool spindle synchronization I B (Spindle-Spindle, Polygon)										△	In a machine containing a workpiece axis and that has a spindle controlled as the rotary tool axis, spindle-spindle polygon machining can be carried out by controlling the rotary tool axis rotation in synchronization with the rotation of the workpiece axis.
3	Tool spindle synchronization I C (Spindle-NC axis, Polygon)										△	This function controls the workpiece (spindle) and tool (NC axis) so that they synchronously rotate at the commanded ratio, allowing polygon machining.
10	Tool spindle synchronization II (Hobbing)										△	This function is to cut the gear with a hob (hob cutter).
11	Spindle speed clamp										○	The spindle rotation speed is clamped between max. rotation speed and min. rotation speed.
13	Spindle oscillation										△	This function reciprocates (oscillates) the spindles with designated amplitude and frequency.
14	Spindle superimposition control										△	Spindles are controlled by superimposing the rotation speed of one spindle on the rotary speed of other spindles. Use this function when the tool spindle needs to be rotated with the superimposed speed on the spindle rotation speed.
15	Multiple spindle synchronization set control										○	By setting the parameter, spindle synchronization I, tool spindle synchronization I A/B (spindle-spindle, polygon), tool spindle synchronization II (hobbing) and spindle superimposition control can be executed simultaneously for multiple sets of spindles.
16	Spindle speed fluctuation detection										△	When this function is valid and the spindle actual speed fluctuates for the commanded speed by the program due to external factors such as load fluctuation, the NC outputs the signal to PLC and the operation error occurs. PLC can take the necessary measure for the fluctuation of the spindle speed using the output signal from the NC.
17	Spindle motor temperature output to PLC										○	This function outputs spindle temperature to an R register assigned for each spindle.
2	Tool functions (T)											
1	Tool functions (T command)										○	The tool function is commanded with an 8-digit number following the address T (T0 to T9999999) to specify the tool No. In the controller for a lathe, the tool compensation (tool length compensation, tool nose wear compensation) Nos. are also indicated.
3	Miscellaneous functions (M)											
1	Miscellaneous functions										○	Miscellaneous function, or M function, is used to command auxiliary functions for NC, such as rotating the spindle forward / backward or stopping it, as well as turning the cooling oil ON/OFF.
2	Multiple M codes in 1 block										○	Multiple sets of M commands can be issued in a block.
3	M code independent output										○	When the M00, M01, M02 or M30 command is issued during an automatic operation (tape, memory, MDI) or by a manual numerical command, the signal of this function is output. It is turned OFF after the miscellaneous function finishes or by the reset & rewind signal.
4	Miscellaneous function finish										○	These signals inform the CNC system that a miscellaneous function (M), spindle function (S), tool function (T) or 2nd miscellaneous function (A, B, C) has been issued, and that the PLC that has received it has completed the required operation. They include miscellaneous function finish signal 1 (FIN1) and miscellaneous function finish signal 2 (FIN2).
5	M code output during axis traveling										○	This function controls the timing at which miscellaneous functions are output, and it outputs a miscellaneous function when the axis reaches the designated position movement.
6	Miscellaneous function command high-speed output										○	This function shortens a processing time per miscellaneous function.
4	2nd miscellaneous functions (B)											
1	2nd miscellaneous functions										○	The code data and start signals are output when an 8-digit number is assigned following the address code A, B or C, whichever does not duplicate the axis name being used.
2	2nd miscellaneous function name extension										○	The 2nd miscellaneous function name same as the additional axes (A, B, C) can be used by specifying the command address of the 2nd miscellaneous function with two characters.
9	Tool compensation											
1	Tool length / Tool position											
1	Tool length offset										○	These commands make it possible to control the axis movement by offsetting the position of the end point of the travel command by the amount set in the tool compensation screen.
2	Tool position offset										—	This function uses commands to control the movement by changing the end point positions of the movement commands to positions which have been extended or reduced for a tool compensation amount.
3	Tool compensation for additional axes										○	The tool compensation for a lathe is valid for the X and Z axes. If an additional axis (Y axis) is added, the tool compensation will be validated for the additional axis.
4	Tool position compensation (G43.7)										△	The position compensation of a turning tool is executed when turning is performed in a machine of machining center system. *Option is "turning machining tool compensation".

class	Machining center system										C80	General explanation
	M800W		M800S		M80W	M80		E80		—		
	M850W	M830W	M850S	M830S	—	M80 TypeA	M80 TypeB	E80 TypeA	E80 TypeB			
5	Multiple-spindle control											Multiple-spindle control is a function that controls all the spindles except the first spindle (main spindle) in a machine tool equipped with the second, third and fourth spindles (sub-spindles) in addition to the first spindle.
1	Multiple-spindle control I										○	This function controls the spindles in a machine tool equipped with several spindles.
2	Multiple-spindle control II										○	With this function, commands to the spindle are performed with one S command, and a signal from the PLC determines which spindle is selected.
6	Spindle orientation										○	This function stops the spindle rotation at a certain position.
7	Spindle position control (Spindle / C axis control)											
1	Spindle position control (Spindle / C axis control)										○	This function enables one spindle drive unit to be also used as the C axis (rotary axis) using an external signal.
2	C axis control during Spindle synchronization										△	This control enables C axis positioning while a long workpiece is controlled by front and back spindles that are in synchronization with each other. Under this control, the machine can perform milling at the center of workpiece.
8	Spindle synchronization											
1	Spindle synchronization I										○	In a machine with two or more spindles, this function controls the rotation speed and phase of one selected spindle (synchronized spindle) in synchronization with the rotation of the other selected spindle (basic spindle). There are two methods for giving commands: G code and PLC.
2	Spindle synchronization II										○	This function is used for a machine with a spindle motor to rotate a guide bushing. It synchronizes the guide bushing spindle (G/B spindle) with the spindle motor used as a reference (basic spindle).
3	Guide bushing spindle synchronization										△	
9	Tool spindle synchronization I (Polygon)											
1	Tool spindle synchronization I A (Spindle-Spindle, Polygon)										△	In a machine containing a rotary tool axis and that has a spindle controlled as the workpiece axis, spindle-spindle polygon machining can be carried out by controlling the workpiece axis rotation in synchronization with the rotation of the rotary tool axis.
2	Tool spindle synchronization I B (Spindle-Spindle, Polygon)										△	In a machine containing a workpiece axis and that has a spindle controlled as the rotary tool axis, spindle-spindle polygon machining can be carried out by controlling the rotary tool axis rotation in synchronization with the rotation of the workpiece axis.
3	Tool spindle synchronization I C (Spindle-NC axis, Polygon)										△	This function controls the workpiece (spindle) and tool (NC axis) so that they synchronously rotate at the commanded ratio, allowing polygon machining.
10	Tool spindle synchronization II (Hobbing)										△	This function is to cut the gear with a hob (hob cutter).
11	Spindle speed clamp										○	The spindle rotation speed is clamped between max. rotation speed and min. rotation speed.
13	Spindle oscillation										△	This function reciprocates (oscillates) the spindles with designated amplitude and frequency.
14	Spindle superimposition control										△	Spindles are controlled by superimposing the rotation speed of one spindle on the rotary speed of other spindles. Use this function when the tool spindle needs to be rotated with the superimposed speed on the spindle rotation speed.
15	Multiple spindle synchronization set control										○	By setting the parameter, spindle synchronization I, tool spindle synchronization I A/B (spindle-spindle, polygon), tool spindle synchronization II (hobbing) and spindle superimposition control can be executed simultaneously for multiple sets of spindles.
16	Spindle speed fluctuation detection										△	When this function is valid and the spindle actual speed fluctuates for the commanded speed by the program due to external factors such as load fluctuation, the NC outputs the signal to PLC and the operation error occurs. PLC can take the necessary measure for the fluctuation of the spindle speed using the output signal from the NC.
17	Spindle motor temperature output to PLC										○	This function outputs spindle temperature to an R register assigned for each spindle.
2	Tool functions (T)											
1	Tool functions (T command)										○	The tool function is commanded with an 8-digit number following the address T (T0 to T9999999) to specify the tool No. In the controller for a lathe, the tool compensation (tool length compensation, tool nose wear compensation) Nos. are also indicated.
3	Miscellaneous functions (M)											
1	Miscellaneous functions										○	Miscellaneous function, or M function, is used to command auxiliary functions for NC, such as rotating the spindle forward / backward or stopping it, as well as turning the cooling oil ON/OFF.
2	Multiple M codes in 1 block										○	Multiple sets of M commands can be issued in a block.
3	M code independent output										○	When the M00, M01, M02 or M30 command is issued during an automatic operation (tape, memory, MDI) or by a manual numerical command, the signal of this function is output. It is turned OFF after the miscellaneous function finishes or by the reset & rewind signal.
4	Miscellaneous function finish										○	These signals inform the CNC system that a miscellaneous function (M), spindle function (S), tool function (T) or 2nd miscellaneous function (A, B, C) has been issued, and that the PLC that has received it has completed the required operation. They include miscellaneous function finish signal 1 (FIN1) and miscellaneous function finish signal 2 (FIN2).
5	M code output during axis traveling										○	This function controls the timing at which miscellaneous functions are output, and it outputs a miscellaneous function when the axis reaches the designated position movement.
6	Miscellaneous function command high-speed output										○	This function shortens a processing time per miscellaneous function.
4	2nd miscellaneous functions (B)											
1	2nd miscellaneous functions										○	The code data and start signals are output when an 8-digit number is assigned following the address code A, B or C, whichever does not duplicate the axis name being used.
2	2nd miscellaneous function name extension										○	The 2nd miscellaneous function name same as the additional axes (A, B, C) can be used by specifying the command address of the 2nd miscellaneous function with two characters.
9	Tool compensation											
1	Tool length / Tool position											
1	Tool length offset										○	These commands make it possible to control the axis movement by offsetting the position of the end point of the travel command by the amount set in the tool compensation screen.
2	Tool position offset										○	This function uses commands to control the movement by changing the end point positions of the movement commands to positions which have been extended or reduced for a tool compensation amount.
3	Tool compensation for additional axes										—	The tool compensation for a lathe is valid for the X and Z axes. If an additional axis (Y axis) is added, the tool compensation will be validated for the additional axis.
4	Tool position compensation (G43.7)										△	The position compensation of a turning tool is executed when turning is performed in a machine of machining center system. *Option is "turning machining tool compensation".

○Standard △Optional □Selection Specifications of separated-type display are classified with "Windows-based" and non-Windows-based

[M800/M80/E80]S/W ver.F2 [C80]S/W ver.B7

class	Lathe system										C80	General explanation		
	M800W		M800S		M80W	M80		E80		—				
	M850W	M830W	M850S	M830S	—	M80 TypeA	M80 TypeB	E80 TypeA	E80 TypeB					
2 Tool radius														
1	Tool radius compensation	—	—	—	—	—	—	—	—	—	—	—	This function provides tool radius compensation. Through a combination of the G command and D address assignment, the actual tool center path is compensated either inside or outside the programmed path by an amount equivalent to the tool radius.	
2	3-dimensional tool radius compensation	△*	△*	—	—	—	—	—	—	—	—	—		This command serves the function of compensating the spherical radius of ball end mills. It compensates the actual tool center path to be either more outside or inside the programmed path by an amount equivalent to the tool radius amount in accordance with the 3-dimensional vectors. *This function is available during program format switch for L system.
3	Tool nose radius compensation (G40 / 41 / 42)	○	○	○	○	○	○	○	○	○	○	○		
4	Automatic decision of nose radius compensation direction (G46 / 40)	○	○	○	○	○	○	○	○	○	○	○		The nose radius compensation direction is automatically determined from the tool tip and the specified movement vector.
5	Tool radius compensation diameter designation	—	—	—	—	—	—	—	—	—	—	—		
3 Tool offset amount														
1 Number of tool offset sets														
1	99 sets	—	—	—	—	—	—	○	○	○	—	—	The number of configurable sets of tool data such as tool length compensation and tool radius compensation.	
2	128 sets	○	○	○	○	—	—	—	—	—	○	—		
3	200 sets	—	—	—	—	—	—	—	—	—	—	—		
4	256 sets	—	—	—	—	○	○	—	—	—	—	△		
5	400 sets	△	△	△	△	—	—	—	—	—	—	—		
6	999 sets	△	△	△	△	—	—	—	—	—	—	—		
2 Offset memory														
1	Tool shape / wear offset amount	○	○	○	○	○	○	○	○	○	○	○	This function registers the tool shape compensation and wear compensation amounts.	
2	Compensation type selection by parameter	—	—	—	—	—	—	—	—	—	—	—		This function switches the tool compensation type to the tool compensation type III with the parameter. This function enables tool compensation for a turning tool by registering the tool compensation amount of the base axes IJK and tool tip point for a machining center system.
3	Number of tool offset sets allocation to part systems	○	○	○	○	○	○	—	—	—	—	—	* Variable number of per-part-system tool offset sets The number of tool offset sets can be set per part system. There are two types of the allocation: "Arbitrary allocation" which allocates the number of tool offset sets to each part system arbitrarily and "Fixed allocation" which automatically allocates the number of tool offset sets to each part system equally, and the type can be selected using the parameter.	
10 Coordinate system														
1 Coordinate system type and setting														
1	Machine coordinate system	○	○	○	○	○	○	○	○	○	○	○	This shows the coordinate systems handled by the NC. The points that can be commanded with the movement command are points in the local coordinate system or machine coordinate system.	
2	Coordinate system setting	○	○	○	○	○	○	○	○	○	○	○		The machine coordinate system is used to express the prescribed positions (such as the tool change position and stroke end position) that are specific to each machine, and it is automatically set immediately upon completion of the first dog-type reference position return after power ON, or immediately after power ON if the absolute position specifications apply.
3	Automatic coordinate system setting	○	○	○	○	○	○	○	○	○	○	○	The zero point position of the program coordinate system can be shifted to an arbitrary position by G92 command.	
4	Workpiece coordinate system selection	○	○	○	○	○	○	○	○	○	○	○		After turning the power ON, even without executing the reference position return, the basic machine coordinate system and the workpiece coordinate system are set automatically.
1	Workpiece coordinate system selection (6 sets)	○	○	○	○	○	○	○	○	○	○	○	When multiple workpieces with the same shape are to be machined, these commands enable the same shape to be machined by executing a single machining program in the coordinate system of each workpiece.	
2	Extended workpiece coordinate system selection (48 sets) G54.1P1 to P48	△	△	△	△	○	○	○	○	○	△	△		In addition to the six workpiece coordinate systems G54 to G59, 48/96 sets of workpiece coordinate systems can be used by assigning G54.1Pn command.
3	Extended workpiece coordinate system selection (96 sets) G54.1P1 to P96	—	—	—	—	—	—	—	—	—	—	—	An external workpiece coordinate offset that serves as a reference for all the workpiece coordinate systems is available outside the workpiece coordinates. By setting the external workpiece coordinate offset, the external workpiece coordinate system can be shifted, and all the workpiece coordinate systems can be simultaneously shifted by an amount equivalent to the offset.	
4	Extended workpiece coordinate system selection (300 sets) G54.1P1 to P300	—	—	—	—	—	—	—	—	—	—	—		This function presets the workpiece coordinate system, which has been shifted by the programmed command or the manual operation, as the workpiece coordinate system which has been offset by the programmed command (G92.1) from the machine zero point by an amount equivalent to the workpiece coordinate offset amount.
5	External workpiece coordinate offset	○	○	○	○	○	○	○	○	○	○	○	This function is for assigning another coordinate system in the workpiece coordinate system currently selected. This enables the workpiece coordinate system to be changed temporarily.	
6	Workpiece coordinate system preset (G92.1)	○	○	○	○	○	○	○	○	○	○	○		The rotary axis includes the rotating type (short-cut valid/invalid) or the linear type (workpiece coordinate position linear type, all coordinate position linear type). The workpiece coordinate position range is 0 to 359.999° for the rotating type, and 0 to 99999.999° for the linear type.
7	Local coordinate system	○	○	○	○	○	○	○	○	○	○	○	By issuing a G code, it is possible to specify the planes for the arc, tool radius compensation, coordinate rotation and other commands.	
8	Coordinate system for rotary axis	○	○	○	○	○	○	○	○	○	○	○		Origin set is a function that shifts the coordinate system so that the current position is set as the zero point in the workpiece coordinate system containing the workpiece coordinate system's offset value. Origin cancel is a function that manually cancels all deviated amounts, and shifts to the designated zero point with the workpiece offset.
9	Plane selection	○	○	○	○	○	○	○	○	○	○	○	The relative position counter can be set to an arbitrary value from the setting and display unit screen.	
10	Origin set / Origin cancel	○	○	○	○	○	○	○	○	○	○	○		For a machine equipped with a table rotary axis, this function corrects installation errors between workpiece coordinate zero point and workpiece reference position.
11	Counter set	○	○	○	○	○	○	○	○	○	○	○	When a workpiece coordinate system which is considered at programming is misaligned with an actual set workpiece coordinate or a workpiece coordinate set by automatic coordinate system setting, the measured workpiece coordinate system can be shifted to the workpiece coordinate system at the program creation so that the machining can be performed without modification of the machining program.	
12	Workpiece position offset for rotary axis	—	—	—	—	—	—	—	—	—	—	—		This function enables the tool to be returned manually to a position specific to the machine (reference position).
13	Workpiece coordinate system shift	○	○	○	○	○	○	○	○	○	○	○	By commanding the G code during an automatic operation, the 1st reference position return is executed. If an intermediate point is commanded, a positioning is made to the point at rapid traverse rate, then each axis returns to its 1st reference position.	
2 Return														
1	Manual reference position return	○	○	○	○	○	○	○	○	○	○	○	By commanding the G code during an automatic operation, the 1st reference position return is executed. If an intermediate point is commanded, a positioning is made to the point at rapid traverse rate, then each axis returns to its 1st reference position.	
2	Automatic 1st reference position return	○	○	○	○	○	○	○	○	○	○	○		

class	Machining center system										C80	General explanation		
	M800W		M800S		M80W	M80		E80		—				
	M850W	M830W	M850S	M830S	—	M80 TypeA	M80 TypeB	E80 TypeA	E80 TypeB					
2 Tool radius														
1	Tool radius compensation	○	○	○	○	○	○	○	○	○	○	○	This function provides tool radius compensation. Through a combination of the G command and D address assignment, the actual tool center path is compensated either inside or outside the programmed path by an amount equivalent to the tool radius.	
2	3-dimensional tool radius compensation	△	△	△	△	—	—	—	—	—	—	—		This command serves the function of compensating the spherical radius of ball end mills. It compensates the actual tool center path to be either more outside or inside the programmed path by an amount equivalent to the tool radius amount in accordance with the 3-dimensional vectors. *This function is available during program format switch for L system.
3	Tool nose radius compensation (G40 / 41 / 42)	△	△	△	△	—	—	—	—	—	—	—		
4	Automatic decision of nose radius compensation direction (G46 / 40)	—	—	—	—	—	—	—	—	—	—	—		The nose radius compensation direction is automatically determined from the tool tip and the specified movement vector.
5	Tool radius compensation diameter designation	○	○	○	○	○	○	○	○	○	○	○		
3 Tool offset amount														
1 Number of tool offset sets														
1	99 sets	—	—	—	—	—	—	—	—	—	○	—	The number of configurable sets of tool data such as tool length compensation and tool radius compensation.	
2	128 sets	—	—	—	—	—	—	—	—	—	—	—		
3	200 sets	—	—	—	—	—	—	—	—	—	—	—		
4	256 sets	—	—	—	—	—	—	—	—	—	—	—		
5	400 sets	△	△	△	△	—	—	—	—	—	—	—		
6	999 sets	△	△	△	△	—	—	—	—	—	—	—		
2 Offset memory														
1	Tool shape / wear offset amount	○	○	○	○	○	○	○	○	○	○	○	This function registers the tool shape compensation and wear compensation amounts.	
2	Compensation type selection by parameter	—	—	—	—	—	—	—	—	—	—	—		This function switches the tool compensation type to the tool compensation type III with the parameter. This function enables tool compensation for a turning tool by registering the tool compensation amount of the base axes IJK and tool tip point for a machining center system.
3	Number of tool offset sets allocation to part systems	○	○	○	○	○	○	—	—	—	—	—	* Variable number of per-part-system tool offset sets The number of tool offset sets can be set per part system. There are two types of the allocation: "Arbitrary allocation" which allocates the number of tool offset sets to each part system arbitrarily and "Fixed allocation" which automatically allocates the number of tool offset sets to each part system equally, and the type can be selected using the parameter.	
10 Coordinate system														
1 Coordinate system type and setting														
1	Machine coordinate system	○	○	○	○	○	○	○	○	○	○	○	This shows the coordinate systems handled by the NC. The points that can be commanded with the movement command are points in the local coordinate system or machine coordinate system.	
2	Coordinate system setting	○	○	○	○	○	○	○	○	○	○	○		The machine coordinate system is used to express the prescribed positions (such as the tool change position and stroke end position) that are specific to each machine, and it is automatically set immediately upon completion of the first dog-type reference position return after power ON, or immediately after power ON if the absolute position specifications apply.
3	Automatic coordinate system setting	○	○	○	○	○	○	○	○	○	○	○	The zero point position of the program coordinate system can be shifted to an arbitrary position by G92 command.	
4	Workpiece coordinate system selection	○	○	○	○	○	○	○	○	○	○	○		After turning the power ON, even without executing the reference position return, the basic machine coordinate system and the workpiece coordinate system are set automatically.
1	Workpiece coordinate system selection (6 sets)	○	○	○	○	○	○	○	○	○	○	○	When multiple workpieces with the same shape are to be machined, these commands enable the same shape to be machined by executing a single machining program in the coordinate system of each workpiece.	
2	Extended workpiece coordinate system selection (48 sets) G54.1P1 to P48	△	△	△	△	○	○	○	○	○	△	△		In addition to the six workpiece coordinate systems G54 to G59, 48/96 sets of workpiece coordinate systems can be used by assigning G54.1Pn command.
3	Extended workpiece coordinate system selection (96 sets) G54.1P1 to P96	—	—	—	—	—	—	—	—	—	—	—	An external workpiece coordinate offset that serves as a reference for all the workpiece coordinate systems is available outside the workpiece coordinates. By setting the external workpiece coordinate offset, the external workpiece coordinate system can be shifted, and all the workpiece coordinate systems can be simultaneously shifted by an amount equivalent to the offset.	
4	Extended workpiece coordinate system selection (300 sets) G54.1P1 to P300	—	—	—	—	—	—	—	—	—	—	—		This function presets the workpiece coordinate system, which has been shifted by the programmed command or the manual operation, as the workpiece coordinate system which has been offset by the programmed command (G92.1) from the machine zero point by an amount equivalent to the workpiece coordinate offset amount.
5	External workpiece coordinate offset	○	○	○	○	○	○	○	○	○	○	○	This function is for assigning another coordinate system in the workpiece coordinate system currently selected. This enables the workpiece coordinate system to be changed temporarily.	
6	Workpiece coordinate system preset (G92.1)	△	△	△	△	—	—	—	—	—	—	—		The rotary axis includes the rotating type (short-cut valid/invalid) or the linear type (workpiece coordinate position linear type, all coordinate position linear type). The workpiece coordinate position range is 0 to 359.999° for the rotating type, and 0 to 99999.999° for the linear type.
7	Local coordinate system	○	○	○	○	○	○	○	○	○	○	○	By issuing a G code, it is possible to specify the planes for the arc, tool radius compensation, coordinate rotation and other commands.	
8	Coordinate system for rotary axis	○	○	○	○	○	○	○	○	○	○	○		Origin set is a function that shifts the coordinate system so that the current position is set as the zero point in the workpiece coordinate system containing the workpiece coordinate system's offset value. Origin cancel is a function that manually cancels all deviated amounts, and shifts to the designated zero point with the workpiece offset.
9	Plane selection	○	○	○	○	○	○	○	○	○	○	○	The relative position counter can be set to an arbitrary value from the setting and display unit screen.	
10	Origin set / Origin cancel	○	○	○	○	○	○	○	○	○	○	○		For a machine equipped with a table rotary axis, this function corrects installation errors between workpiece coordinate zero point and workpiece reference position.
11	Counter set	○	○	○	○	○	○	○	○	○	○	○	When a workpiece coordinate system which is considered at programming is misaligned with an actual set workpiece coordinate or a workpiece coordinate set by automatic coordinate system setting, the measured workpiece coordinate system can be shifted to the workpiece coordinate system at the program creation so that the machining can be performed without modification of the machining program.	
12	Workpiece position offset for rotary axis	△	△	△	△	○	○	—	—	—	—	—		This function enables the tool to be returned manually to a position specific to the machine (reference position).
13	Workpiece coordinate system shift	—	—	—	—	—	—	—	—	—	—	—	By commanding the G code during an automatic operation, the 1st reference position return is executed. If an intermediate point is commanded, a positioning is made to the point at rapid traverse rate, then each axis returns to its 1st reference position.	
2 Return														
1	Manual reference position return	○	○	○	○	○	○	○	○	○	○	○	By commanding the G code during an automatic operation, the 1st reference position return is executed. If an intermediate point is commanded, a positioning is made to the point at rapid traverse rate, then each axis returns to its 1st reference position.	
2	Automatic 1st reference position return	○	○	○	○	○	○	○	○	○	○	○		

M800/M80/E80/C80 SERIES SPECIFICATIONS LIST

M800/M80/E80/C80 SERIES SPECIFICATIONS LIST

○Standard △Optional □Selection Specifications of separated-type display are classified with "Windows-based" and non-Windows-based

[M800/M80/E80]S/W ver.F2 [C80]S/W ver.B7

class		Lathe system										C80
		M800W		M800S		M80W	M80		E80			
		M850W	M830W	M850S	M830S	—	M80 TypeA	M80 TypeB	E80 TypeA	E80 TypeB		
3	2nd, 3rd, 4th reference position return	○	○	○	○	○	○	○	○	○	○	○
4	Reference position check	○	○	○	○	○	○	○	○	○	○	○
5	Absolute position detection	○	○	○	○	○	○	○	○	○	○	○
6	Tool exchange position return	○	○	○	○	○	○	○	○	○	○	○
11 Operation support functions												
1 Program control												
1	Optional block skip	○	○	○	○	○	○	○	○	○	○	○
2	Optional block skip addition	○	○	○	○	○	○	—	—	○	○	○
3	Single block	○	○	○	○	○	○	○	○	○	○	○
2 Program test												
1	Dry run	○	○	○	○	○	○	○	○	○	○	○
2	Machine lock	○	○	○	○	○	○	○	○	○	○	○
3	Miscellaneous function lock	○	○	○	○	○	○	○	○	○	○	○
4	Graphic check											
1	Graphic check	○	○	○	○	○	○	○	○	○	○	—
2	3D solid program check	○	○	○	○	○	○	○	○	○	○	—
3	Graphic check rotary axis drawing	△	△	△	△	○	○	○	○	○	○	—
5	Graphic trace											
1	Graphic trace	○	○	○	○	○	○	○	○	○	○	—
2	Graphic trace rotary axis drawing	△	△	△	△	○	○	○	○	○	○	—
6	Machining time computation	○	○	○	○	○	○	○	○	○	○	—
7	Manual arbitrary reverse run (Program check operation)	△	△	△	△	○	○	○	○	○	○	△
8	High-speed simple program check	○	○	○	○	○	○	○	○	○	○	○
3 Program search / start / stop												
1	Program search	○	○	○	○	○	○	○	○	○	○	○
2	Sequence number search	○	○	○	○	○	○	○	○	○	○	○
3	Verification stop	○	○	○	○	○	○	—	—	○	○	○
4	Program restart	○	○	○	○	○	○	○	○	○	○	○
5	Automatic operation start	○	○	○	○	○	○	○	○	○	○	○
6	NC reset	○	○	○	○	○	○	○	○	○	○	○
7	Feed hold	○	○	○	○	○	○	○	○	○	○	○
8	Search & Start	○	○	○	○	○	○	○	○	○	○	○
10	Auto-restart	○	○	○	○	○	○	○	○	○	○	○
4 Interrupt operation												
1	Manual interruption	○	○	○	○	○	○	○	○	○	○	○
2	Automatic operation handle interruption	○	○	○	○	○	○	○	○	○	○	○
3	Manual absolute switch	○	○	○	○	○	○	○	○	○	○	○
4	Thread cutting cycle retract	○	○	○	○	○	○	○	—	—	○	○
5	Tapping retract	○	○	○	○	○	○	○	○	○	○	○
6	Manual numerical value command	○	○	○	○	○	○	○	○	○	○	○
7	Arbitrary reverse run	—	—	—	—	—	—	—	—	—	—	—
8	MDI interruption	○	○	○	○	○	○	○	○	○	○	○
9	Simultaneous operation of manual and automatic modes	○	○	○	○	○	○	○	○	○	○	○
10	Simultaneous operation of JOG and handle modes	○	○	○	○	○	○	○	○	○	○	○
11	Reference position retract	○	○	○	○	○	○	○	○	○	○	○

		Machining center system										General explanation	
		M800W		M800S		M80W	M80		E80		C80		
		M850W	M830W	M850S	M830S	—	M80 TypeA	M80 TypeB	E80 TypeA	E80 TypeB	—		
		○	○	○	○	○	○	○	○	○	○	○	As in the automatic 1st reference position return, by commanding the G code during an automatic operation, an axis returns to a certain position specific to the machine (2nd/3rd/4th reference position).
		○	○	○	○	○	○	○	○	○	○	○	By issuing a G code, a machining program where the tool is programmed to start off from the reference position and return to the reference position can be checked if the tool will return successfully to the reference position.
		○	○	○	○	○	○	○	○	○	○	○	With this function, a battery stores the relation of the actual machine position and the machine coordinate kept in the CNC even during the power OFF, and an automatic operation is enabled without executing a reference position return.
		○	○	○	○	○	○	○	○	○	○	○	By specifying the tool change position in a parameter and also assigning a tool change position return command in a machining program, the tool can be changed at the most appropriate position.
		○	○	○	○	○	○	○	○	○	○	○	
		○	○	○	○	○	○	○	○	○	○	○	When "/" (slash code) is programmed at the head of a block, and the optional block skip input signal from the external source is turned ON for automatic operation, the block with the "/" code is skipped.
		○	○	○	○	○	○	○	○	—	—	○	When "/n (n: 1 to 9)" is programmed at the head of a block, and the optional block skip input n signal from the external source is turned ON for automatic operation, the block with the "/n" code is skipped.
		○	○	○	○	○	○	○	○	○	○	○	The commands for automatic operation can be executed one block at a time (block stop) by turning ON the single block input signal.
		○	○	○	○	○	○	○	○	○	○	○	F code feed commands for automatic operation can be switched to the manual feedrate data of the machine operation board by turning ON the dry run input signal.
		○	○	○	○	○	○	○	○	○	○	○	When the machine lock input signal is set to ON, the CNC operations can be executed without actually moving the NC axis.
		○	○	○	○	○	○	○	○	○	○	○	When the "External input" signal or "Miscellaneous function lock" signal is turned ON, the output signals of M, S, T, and B (2nd miscellaneous function) will not be output to the PLC. This is useful when checking only travel commands in a program check.
		○	○	○	○	○	○	○	○	○	○	○	This function traces the programmed movement path without executing an automatic operation. It enables three-dimensional drawing and also rotary axis drawing. By using this function, machining programs can be checked before they are actually run.
		○	○	○	○	○	○	○	○	○	○	○	
		○	○	○	○	○	○	○	○	○	○	○	This function traces the machine tool's machine positions. It draws the movement path of an actual automatic or manual operation, and the tool tip movement path. The function also monitors the machine operations during machining. It enables the drawing of a rotary axis as well.
		○	○	○	○	○	○	○	○	○	○	○	This function analyzes the machining program without moving the axis and calculates the approximate time required for machining.
		△	△	△	△	○	○	○	○	—	—	△	The manual arbitrary reverse run can be performed by controlling the feedrate being in the automatic operation in the memory or MDI mode in proportion to the manual feedrate by jog or the rotation speed by manual handle.
		○	○	○	○	○	○	○	○	○	○	○	This function checks whether a program error occurs by operating the machining program without the axes movements. The estimated machining time can be checked in time shorter than the actual execution time of the machining program.
		○	○	○	○	○	○	○	○	○	○	○	
		○	○	○	○	○	○	○	○	○	○	○	This function specifies the program No. of the program to run automatically and calls the program.
		○	○	○	○	○	○	○	○	○	○	○	Blocks can be indexed by setting the program No., sequence No. and block No. of the program to run automatically.
		○	○	○	○	○	○	○	○	○	○	○	This function enables the single block stop status to be established at any block without having to turn the SINGLE BLOCK switch ON.
		○	○	○	○	○	○	○	○	○	○	○	When a machining program is to be resumed after suspended midway due to tool damage or for some other reason, this function searches the program and the block to resume and enables machining to be resumed from the block.
		○	○	○	○	○	○	○	○	○	○	○	With the input of the automatic operation start signal (change from ON to OFF), automatic operation of the program that was found by an operation search is started by the controller (or the halted program is restarted).
		○	○	○	○	○	○	○	○	○	○	○	This function enables the controller to be reset.
		○	○	○	○	○	○	○	○	○	○	○	When the feed hold signal is set to ON during automatic operation, the machine feed is immediately decelerated and stopped.
		○	○	○	○	○	○	○	○	○	○	○	If the "Search & Start" signal is input when the memory mode is selected, the designated machining program is searched and executed from the beginning.
		○	○	○	○	○	○	○	○	○	○	○	A machining program is restarted automatically at the completion of the machining program execution.
		○	○	○	○	○	○	○	○	○	○	○	Manual interrupt is a function that enables manual operations to be performed during automatic operation.
		○	○	○	○	○	○	○	○	○	○	○	The handle command can interrupt and be superimposed onto a command without suspending automatic operation to move the machine by rotating the manual pulse generator during automatic operation.
		○	○	○	○	○	○	○	○	○	○	○	The program absolute positions are updated by an amount equivalent to the distance by which the tool is moved manually when the manual absolute switch signal is turned ON.
		○	○	○	○	○	○	○	○	○	○	○	This function suspends the thread cutting cycle if a feed hold signal has been input during thread cutting cycle.
		○	○	○	○	○	○	○	○	○	○	○	If tapping is interrupted by a reset or emergency stop signal that is input during tapping and the tap is left engaged inside the workpiece, the tap tool engaged inside the workpiece can be rotated in the reverse direction so that it will be disengaged by inputting the tap retract signal.
		○	○	○	○	○	○	○	○	○	○	○	On the screen of the setting and display unit, the M, S and T (and B when 2nd miscellaneous function is valid) commands can be executed by setting numerical values and pressing [INPUT].
		○	○	○	○	○	○	○	○	○	○	○	This function allows a program to run the executed blocks backward after the block stop in the automatic operation.
		○	○	○	○	○	○	○	○	○	○	○	This function enables MDI programs to be executed during automatic operation in the single block stop status. When the modal status is changed in a MDI program, the modal status in the automatic operation mode is also changed.
		○	○	○	○	○	○	○	○	○	○	○	This function enables manual operations to be performed during automatic operation by selecting an automatic operation mode (tape, MDI or memory) and manual mode (handle, step, jog or manual reference position return) simultaneously. (Arbitrary feed based on the PLC is also possible.)
		○	○	○	○	○	○	○	○	○	○	○	When executing the jog feed and handle feed, both these feeds are available without changing the mode each time by inputting the jog mode signal and simultaneous operation of jog and handle modes signal to the control unit.
		○	○	○	○	○	○	○	○	○	○	○	When the retract signal is turned ON during the automatic and manual operation, this function can retract the tool immediately to a set reference position.

○Standard △Optional □Selection Specifications of separated-type display are classified with "Windows-based" and non-Windows-based

[M800/M80/E80]S/W ver.F2 [C80]S/W ver.B7

class	Lathe system										C80	General explanation
	M800W		M800S		M80W	M80		E80		—		
	M850W	M830W	M850S	M830S	—	M80 TypeA	M80 TypeB	E80 TypeA	E80 TypeB			
12	Tool retract and return	△	△	△	△	○	○	○	—	—	—	
13	Skip retract	—	—	—	—	—	—	—	—	—	—	
14	PLC interruption	○	○	○	○	○	○	○	○	○	○	
16	Machining interruption	—	—	—	—	—	—	—	—	—	△	
12 Program support functions												
1 Machining method support functions												
1 Program												
1	Subprogram control [Layers]	○10	○10	○10	○10	○10	○10	○10	○10	○10	○8	
2	Figure rotation	—	—	—	—	—	—	—	—	—	—	
3	Scaling	—	—	—	—	—	—	—	—	—	—	
4	Axis name switch	○	○	○	○	○	○	○	○	○	○	
2 Macro program												
1	User macro [Layers]	○4	○4	○4	○4	○4	○4	○4	○4	○4	○4	
2	Machine tool builder macro	○	○	○	○	○	○	○	○	○	○	
3	Macro interruption	○	○	○	○	○	○	○	○	○	○	
4	Variable command											
1	200 sets	—	—	—	—	—	—	—	—	—	○	
2	600 sets	—	—	—	—	—	—	—	—	—	—	
3	700 sets	○	○	○	○	○	○	—	—	—	—	
4	8000 sets	△	△	△	△	○	○	—	—	—	—	
6	(600+100×number of part systems) sets	○	○	○	○	○	○	—	—	—	—	
7	(7900+100×number of part systems) sets	△	△	△	△	○	○	—	—	—	—	
3 Fixed cycle												
1	Fixed cycle for drilling	○	○	○	○	○	○	○	○	○	○	
2	Fixed cycle for drilling (Type II)	○	○	○	○	○	○	○	○	○	○	
3	Special fixed cycle	—	—	—	—	—	—	—	—	—	—	
4	Fixed cycle for turning machining	○	○	○	○	○	○	○	○	○	○	
5	Compound type fixed cycle for turning machining	△	△	△	△	○	○	○	○	○	○	
6	Compound type fixed cycle for turning machining (Type II)	△	△	△	△	○	○	○	○	○	△	
7	Small-diameter deep-hole drilling cycle	△	△	△	△	—	—	—	—	—	—	
4 Mirror image												
1	Mirror image by parameter setting	○	○	○	○	○	○	○	○	○	○	
2	Mirror image by external input	○	○	○	○	○	○	○	○	○	○	
3	Mirror image by G code	—	—	—	—	—	—	—	—	—	—	
4	Mirror image for facing tool posts	○	○	○	○	○	○	—	—	—	○	
5	T code mirror image for facing tool posts	○	○	○	○	○	○	—	—	—	○	
5 Coordinate system operation												
1	Coordinate rotation by program	△	△	△	△	○	○	—	—	—	△	
2	Coordinate rotation by parameter	—	—	—	—	—	—	—	—	—	—	
3	3-dimensional coordinate conversion	△	△	△	△	○	○	—	—	—	—	
6 Dimension input												
1	Corner chamfering / Corner R	△	△	△	△	○	○	○	○	○	△	
2	Linear angle command	△	△	△	△	○	○	○	○	○	△	
3	Geometric command	○	○	○	○	○	○	○	○	○	○	
4	Polar coordinate command	—	—	—	—	—	—	—	—	—	—	
7 Axis control												
1 Chopping												
1	Chopping	△	△	△	△	○	○	○	—	—	△	
2 Normal line control												
2	Normal line control	—	—	—	—	—	—	—	—	—	—	
3 Circular cutting												
3	Circular cutting	—	—	—	—	—	—	—	—	—	—	

Machining center system											General explanation
M800W		M800S		M80W	M80		E80		C80	—	
M850W	M830W	M850S	M830S	—	M80 TypeA	M80 TypeB	E80 TypeA	E80 TypeB			
△	△	△	△	○	○	○	—	—	—	—	Even if the machining program's operation is halted and the tool is retracted to change the tool or check the workpiece, etc., the tool can be returned to the halted point (machining halted point) and resume machining.
○	○	○	○	○	○	○	—	—	○	○	This function is used to return in the direction opposite the travel direction when the skip signal is input during G31 command.
○	○	○	○	○	○	○	○	○	○	○	The interrupt program set with the R register is executed with the signals from the PLC during single block stop in program operation or during the manual mode.
—	—	—	—	—	—	—	—	—	—	△	Machining interruption is a function which enables interrupt operations while a program is normally executed.
○10	○10	○10	○10	○10	○10	○10	○10	○10	○10	○8	When the same pattern is repeated during machining, the machining pattern is registered as one subprogram, which can be called from the main program as required, thereby realizing the same machining easily. This enables the efficient use of programs.
△	△	△	△	—	—	—	—	—	—	—	If the same pattern is used repeatedly on a concentric circle, one of the rotary machining patterns can be registered as a subprogram. When the subprogram is called from the main program, if the rotation center is designated, a path similar to the rotary phase can be easily created on the concentric circle. This simplifies the creation of a program.
△	△	△	△	○	○	○	○	—	—	△	The shape commanded by a program can be extended or reduced to the desired size by applying a scale factor to the movement axis command position.
—	—	—	—	—	—	—	—	—	—	—	The axis name switch function switches the name of a command axis and a control axis.
○4	○4	○4	○4	○4	○4	○4	○4	○4	○4	○4	In order to execute one integrated function, a group of control and arithmetic instructions can be used and registered as a macro program.
○	○	○	○	○	○	○	○	○	○	○	This function enables macro programs exclusively designed for use by a specific machine tool builder to be registered in addition to the regular user macro programs.
○	○	○	○	○	○	○	○	○	○	○	By inputting a user macro interrupt signal from the PLC, the program being currently executed is interrupted and other programs can be called instead.
—	—	—	—	—	—	—	—	—	○	—	Programming can be made flexible and versatile by designating variables instead of directly assigning numbers to addresses in programs and by supplying the values of those variables as required when running the programs.
○	○	○	○	○	○	○	○	—	—	○	Arithmetic operations (adding, subtracting, multiplying and dividing) can also be conducted for the variables.
△	△	△	△	○	○	—	—	—	—	—	
○	○	○	○	○	○	○	○	○	○	○	
—	—	—	—	—	—	—	—	—	—	—	These functions enable drilling, tapping and other hole machining cycles to be assigned in a simple 1-block program. Special fixed cycles must always be used in combination with fixed cycles.
△	△	△	△	○	○	○	○	○	○	△	
○	○	○	○	○	○	—	—	—	—	—	The shape normally programmed in several blocks for rough cutting, etc. in the turning machining can be commanded in one block. This function is useful for simplifying machining programs.
—	—	—	—	—	—	—	—	—	—	—	
○	○	○	○	○	○	○	—	—	—	—	In deep hole drilling, cutting and retract are repeated and the workpiece is machined multiple times. In addition, when PLC signals are input during cutting, the cutting for the time concerned is skipped. In this way, the load applied to the tool is reduced.
○	○	○	○	○	○	○	○	○	○	○	A parameter is used to designate the axis for which the mirror image function is to be executed before the machining program is run.
○	○	○	○	○	○	○	○	○	○	○	Signals from an external device (PLC) request the mirror image operation either during or before the execution of a machining program.
○	○	○	○	○	○	○	○	○	○	○	Using a program for the left or right side of an image, this function can machine the other side of the image when a left/right symmetrical shape is to be cut.
—	—	—	—	—	—	—	—	—	—	—	With machines in which the base tool post and the facing tool post are integrated in one post, this function enables the programs prepared for cutting at the base side to be executed by the tools on the facing side as well.
—	—	—	—	—	—	—	—	—	—	—	When tools that correspond to tool Nos. 1 to 64 are selected (T commands) but these are the tool Nos. for which the facing tool post mirror image function has already been designated with a parameter, the status equivalent to G68 (facing tool post mirror image ON) is established.
△	△	△	△	○	○	○	○	○	○	△	When it is necessary to machine a complicated shape at a position that has been rotated with respect to the coordinate system, you can machine a rotated shape by programming the shape prior to rotation on the local coordinate system, and then specifying the rotation center coordinates and rotation angle by means of this coordinate rotation command.
△	△	△	△	—	—	—	—	—	—	—	If a deviation occurs between the workpiece alignment line and the machine coordinate system's coordinate axis when the workpiece is mounted, the machine can be controlled to rotate the machining program coordinates according to the workpiece alignment line deviation.
△	△	△	△	○	○	—	—	—	—	△	With the 3-dimensional coordinate conversion function, a new coordinate system can be defined by rotating and moving in parallel the zero point in respect to the X, Y and Z axes of the currently set workpiece coordinate system.
△	△	△	△	○	○	○	○	○	○	△	This function executes corner processing by automatically inserting a straight line or arc in the commanded amount between two consecutive travel blocks.
△	△	△	△	○	○	○	○	○	—	△	The end point coordinates are automatically calculated by assigning one element (one component of the selected plane) of the end point coordinates and the linear angle.
△	△	△	△	○	○	○	○	○	—	—	When it is difficult to find the intersection point of two straight lines with a continuous linear interpolation command, this point can be calculated automatically by programming the command for the angle of the straight lines.
△	△	△	△	○	○	○	—	—	—	△	With this function, the end point position is commanded with the radius and angle.
△	△	△	△	○	○	○	—	—	—	△	This function continuously raises and lowers the chopping axis independently of program operation. During the grinding operation, chopping can produce a better surface accuracy than using abrasive grain.
○	○	○	○	○	○	○	—	—	—	○	This function controls the swiveling of the C axis (rotary axis) so that the tool is always pointing in the normal line direction for the X and Y axes movement commands during program operation.
○	○	○	○	○	○	○	○	○	○	○	In circular cutting, a system of cutting steps are performed; first, the tool departs from the center of the circle, and by cutting along the inside circumference of the circle, it draws a complete circle, then it returns to the center of the circle.

○Standard △Optional □Selection Specifications of separated-type display are classified with "Windows-based" and non-Windows-based

[M800/M80/E80]S/W ver.F2 [C80]S/W ver.B7

class	Lathe system										C80
	M800W		M800S		M80W	M80		E80		—	
	M850W	M830W	M850S	M830S	—	M80 TypeA	M80 TypeB	E80 TypeA	E80 TypeB		
4	Vibration cutting control										—
8	Multi-part system control										
1	Timing synchronization between part systems										○
2	Start point designation timing synchronization										○
3	Mixed control										
1	Mixed control (cross axis control)										△
2	Arbitrary axis exchange control										△
4	Control axis superimposition										
1	Control axis superimposition										△
2	Arbitrary axis superimposition control										△
5	Control axis synchronization between part systems										△
6	Balance cut										○
7	Common memory for part systems										○
8	Multi-part system simultaneous thread cutting										
1	Two-part system simultaneous thread cutting										△
2	Multi-part system simultaneous thread cutting										△
9	Multi-part system program management										○
10	Synchronization between part systems										
1	Single block between part systems										△
2	Dwell / Miscellaneous function time override										△
3	Synchronization between part systems OFF										△
11	Sub part system control I										△
12	Sub part system control II										△
9	Data input / output by program										
1	Parameter input by program										○
2	Compensation data input by program										○
3	Tool/Material shape input by program										○
5	API section and sub-section Nos. input / output by program										○
6	R-Navii data input by program										—
10	Machining modal										
1	Tapping mode										○
2	Cutting mode										○
11	High-speed parts machining										
1	Rapid traverse block overlap										△
2	Machining accuracy support functions										
1	Automatic corner override										○
2	Deceleration check										
1	Exact stop check mode										○
2	Exact stop check										○
3	Error detection										○
4	Programmable in-position check										○
5	Automatic error detection										△

class	Machining center system										General explanation
	M800W		M800S		M80W	M80		E80		C80	
	M850W	M830W	M850S	M830S	—	M80 TypeA	M80 TypeB	E80 TypeA	E80 TypeB		
—	—	—	—	—	—	—	—	—	—	—	While cutting machining is performed, the chips can be dispersed by applying vibration in synchronization with the spindle rotation to the feed axis so that an air-shot area is made. Difficult-to-cut workpieces such as stainless steel can be machined easily and at high speed. In addition, this function can reduce the heat generated by machining and extend tool life. * A vibration cutting expansion unit is required. * Only one axis per programmed part system vibrates. Even for a cutting command involving two or more axes (e.g. taper machining), only one axis selected vibrates.
○	○	○	○	○	○	○	—	—	—	○	The multi-axis, multi-part system compound control CNC system can simultaneously run multiple machining programs independently. This function is used in cases when, at some particular point during operation, the operations of different part systems are to be synchronized or in cases when the operation of only one part system is required.
○	○	○	○	○	○	○	—	—	—	○	The synchronizing point can be placed in the middle of a block by designating the start point.
—	—	—	—	—	—	—	—	—	—	—	This function enables any axis to be replaced with another axis between part systems. There are two methods for giving commands: G code and PLC.
△	△	△	△	○	○	—	—	—	—	△	An arbitrary axis can be exchanged freely across part systems in the multiple part systems. The machining can be freed by exchanging an axis which can be commanded for machining programs in each part system.
—	—	—	—	—	—	—	—	—	—	—	This function enables to superimpose on and control an axis in a part system with an axis in another part system. There are two methods for giving commands: G code and PLC.
—	—	—	—	—	—	—	—	—	—	—	The arbitrary control axis in other part system can be moved by superimposing on the movement command for the arbitrary control axis in own part system.
—	—	—	—	—	—	—	—	—	—	—	Synchronization control enables an arbitrary control axis in another part system to move in synchronization with the movement command assigned to an arbitrary control axis. There are two methods for giving commands: G code and PLC.
—	—	—	—	—	—	—	—	—	—	—	The deflection can be minimized by holding tools simultaneously from both sides of the workpiece and using them in synchronization to machine the workpiece (balance cutting). In addition, since the workpiece is machined by two tools, the machining time is reduced.
—	—	—	—	—	—	—	—	—	—	—	For a machine with multiple part systems, the common variables and tool compensation memory which exist for each part system can be made common to all part systems by setting the parameters.
—	—	—	—	—	—	—	—	—	—	—	This function performs synchronous thread cutting for the same spindle using the 1st and 2nd part systems.
—	—	—	—	—	—	—	—	—	—	—	This function performs thread cutting for the same spindle in the different part system. This has two commands: the command (G76.1) for simultaneously cutting threads in multiple places, which is known as "multi-part system simultaneous thread cutting cycle I", and the command (G76.2) for simultaneously cutting a thread by two part systems, which is known as "two-part system simultaneous thread cutting cycle II".
○	○	○	○	○	○	○	—	—	—	○	Separate programs, used in each part system, can be managed under a common name in a multi-part system.
—	—	—	—	—	—	—	—	—	—	—	Single block operation with part systems synchronized is the function for executing single block operation while maintaining the synchronization among the part systems when two or more part systems are operated in the multi-part system. When one part system has been stopped by single block stop, the other part systems pause in the cycle operation.
—	—	—	—	—	—	—	—	—	—	—	Override can be applied to dwell time and miscellaneous function finish wait time of all part systems. The synchronization among part systems can be maintained when the multiple machining programs are operated with override.
—	—	—	—	—	—	—	—	—	—	—	Synchronization among part systems and feedrate change are turned OFF in a part of a machining program to eliminate a synchronization relation among part systems by single block operation with part systems synchronized or variation of a machining program feedrate by dry run. This function is effective mainly in blocking the cycle operation pause or feedrate variation in only some of part systems when the sub part system control II function is being used.
△	△	△	△	△	○	○	—	—	—	△	This function activates and operates any non-operating part system (sub part system) in the multi-part system. An auxiliary axis machining program can be controlled in the sub part system by commanding Sub part system control I (G122) from the main part system.
—	—	—	—	—	—	—	—	—	—	—	This function activates and operates any non-operating part system (sub part system) in the multi-part system. Using sub part systems enables parallel operation between an operating program in main part system and a program called with Sub part system control II (G144).
○	○	○	○	○	○	○	○	○	○	○	The parameters set from the display can be changed using machining programs.
○	○	○	○	○	○	○	○	○	○	○	The value of the workpiece coordinate systems selected can be set or changed using program commands. The tool compensation amounts, that are set from the display can be input using program commands.
○	○	○	○	○	○	○	○	○	○	○	Tool shape data on the tool management screen and workpiece shape data of the 3D solid program check can be set with the machining program.
○	○	○	○	○	○	○	○	○	○	○	NC internal data can be read/written by specifying the section number, sub-section number, part system number and axis number using system variables.
△	△	△	△	△	○	○	—	—	—	—	The R-Navii setup parameter can be set from the machining program. The setting value can be checked and the machining surface can be selected on the setup screen for the parameter set from the machining program.
○	○	○	○	○	○	○	○	○	○	○	When tapping mode commands are issued, the CNC system is set to the internal control modes required for tapping.
○	○	○	○	○	○	○	○	○	○	○	When a cutting mode command is issued, the CNC system is set to the cutting mode that enables a smoothly cut surface.
△	△	△	△	△	○	○	—	—	—	△	This function enables the next block to start (overlap) without waiting for positioning (G00) or reference position return (G28/G30). Consequently, cycle time of machining can be reduced.
○	○	○	○	○	○	○	○	○	○	○	To prevent machining surface distortion due to increase in the cutting load when cutting corners, this function automatically applies an override on the cutting feedrate so that the cutting amount is not increased for a set time at the corner.
○	○	○	○	○	○	○	○	○	○	○	
○	○	○	○	○	○	○	○	○	○	○	This function decelerates and stops a motor before executing the next block, which reduces the impact on the machine caused by a rapid change of feedrate, and prevents a corner from being machined round.
○	○	○	○	○	○	○	○	○	○	○	
—	—	—	—	—	—	—	—	—	—	—	This function is effective to reduce the extension of cycle time for the cutting at the corner and realize the high edge accurate machining.

○Standard △Optional □Selection Specifications of separated-type display are classified with "Windows-based" and non-Windows-based

[M800/M80/E80]S/W ver.F2 [C80]S/W ver.B7

class	Lathe system										C80	General explanation
	M800W		M800S		M80W	M80		E80		—		
	M850W	M830W	M850S	M830S	—	M80 TypeA	M80 TypeB	E80 TypeA	E80 TypeB			
3 High-speed and high-accuracy functions [kBPM; k Block per Minute]												
1 High-speed machining mode												
1	High-speed machining mode I (G05P1) maximum [kBPM]	△33.7	△33.7	△33.7	△33.7	○33.7	○33.7	—	—	—	△33.7	This function runs a machining program that approximates a free curve with fine segments at a high speed.
2	High-speed machining mode II (G05P2) maximum [kBPM]	△168	△168	△168	△168	○67.5	○67.5	—	—	—	△67.5	
2 High-accuracy control												
1	High-accuracy control (G61.1 / G08)	△	△	△	△	○	○	○	○	○	△	Machining errors caused by delays in control systems can be inhibited. This function is useful for machining which needs to make an edge at a corner or reduce an error from an inner route of curved shape.
2	Multi-part system simultaneous high-accuracy control	△	△	△	△	—	—	—	—	—	—	
3	SSS control	△	△	△	△	○	○	○	—*	—*	—	High-accuracy control and high-speed machining mode are available respectively in all part systems. The simultaneous usage of high-accuracy control and high-speed machining mode (including High-speed high-accuracy control I/II/III) are available only in part systems which are limited by the parameter. * Up to 2 part systems
4	Tolerance control	△	△	△	△	○	○	○	○	○	—	
5	Variable-acceleration pre-interpolation acceleration / deceleration	—	—	—	—	—	—	—	—	—	—	With SSS (Super Smooth Surface) control, the large area path information is used instead of just the angle between the blocks. Thus, optimum speed control that is not adversely affected by minute steps or waviness is possible. This enables machining with a fewer scratches and streaks on the cutting surface compared to the normal high-accuracy control function. Multiple part systems simultaneous high-accuracy function is required to conduct the SSS control in the second or following part systems. * eSSS (There are limitations on the setting of some parameters.)
6	High-accuracy acceleration / deceleration time constant extension	—	—	—	—	—	—	—	—	—	—	
7	Axis-specific acceleration tolerance control	△	△	△	△	—	—	—	—	—	—	This function enables the smooth operation within the tolerance error range. The desired machining result can be obtained with simple parameter adjustment.
3 High-speed high-accuracy control												
1	High-speed high-accuracy control I (G05.1Q1) maximum [kBPM]	△67.5	△67.5	△67.5	△67.5	○33.7	○33.7	—	—	—	△33.7	This function can perform the acceleration / deceleration during SSS control by setting diverse acceleration to each axis. Therefore, the acceleration for the axis with high responsiveness can be larger than before so that cycle time can be reduced especially in the indexing machining.
2	High-speed high-accuracy control II (G05P10000) maximum [kBPM]	△168	△168	△168	△168	○67.5	○67.5	—	—	—	△67.5	
3	High-speed high-accuracy control III (G05P20000) maximum [kBPM]	—	—	—	—	—	—	—	—	—	—	This extends the upper limit of cutting feed time constant from 5,000[ms] to 30,000[ms] for acceleration/deceleration before interpolation. * 1st part system only
4	Smooth fairing	—	—	—	—	—	—	—	—	—	—	
4	Machining condition selection I	○	○	○	○	○	○	—	—	—	○	The acceleration to be generated at a seam between blocks is evaluated for each axis to control deceleration so that the seam is passed at the optimum speed. This enables highly accurate edge machining. * 1st part system only
5	Direct command mode	△	△	△	△	—	—	—	—	—	—	
4 Programming support functions												
1	Playback	△	△	△	△	—	—	—	—	—	—	A machining program that approximates a free curve with fine segments can be run at a high speed and with a high accuracy. This function is effective in decreasing the cycle time of machining dies with free curves. This function is also useful in machining which needs to make an edge at a corner or reduce a path error from inner route of curved shape because the high-accuracy control mode is turned ON automatically.
3	Interactive cycle insertion	△	△	△	△	○	○	○	○	○	—	
4	Simple programming (NAVI MILL / LATHE)	△	△	△	△	○	○	○	○	○	—	A path can be smoother by compensating commanded positions of a machining program. This function is useful when executing a fine segment program to machine smoothly at low speed or a rough machining program with long segment to machine smoothly.
5	G code guidance	○	○	○	○	○	○	○	○	○	○	
7	DXF data input	△	△	△	△	○	○	—	—	—	—	The machining condition parameter set which consists of parameters related to the high-accuracy control can be configured in advance for each machining application (such as part machining or die machining) or machining process (such as rough or finishing), and it can be switched according to the purpose.
13 Machine accuracy compensation												
1 Static accuracy compensation												
1	Backlash compensation	○	○	○	○	○	○	○	○	○	○	By reducing the load applied during the NC program analysis and interpolation to the minimum possible level, the machining programs expressed in fine segments are executed at a high processing speed.
2	Memory-type pitch error compensation [sets]	○32	○32	○32	○32	○16	○16	○16	○16	○16	○10	
3	Memory-type relative position error compensation	○	○	○	○	○	○	○	○	○	○	This function enables creation of a program while proceeding with simple machining by manual (handle or job) feed or mechanical handle feed.
4	External machine coordinate system compensation	△	△	△	△	○	○	○	○	○	△	
5	Circular radius error compensation	△	△	△	△	○	○	○	—	—	△	This function enables to interactively insert a cycle to assist in the machining and setup for the program opening on the edit screen. The cycle can easily be inserted by editing data in an interactive window.
6	Ball screw thermal expansion compensation	△	△	△	△	○	○	○	○	○	△	
7	Rotation center error compensation	△	△	△	△	—	—	—	—	—	—	Create a part program by using NAVI MILL (for machining center system) or NAVI LATHE (for lathe system).
8	Position-dependent gradually increasing-type backlash compensation	△	△	△	△	○	○	○	—	—	△	
9	Bidirectional pitch error compensation	△	△	△	△	○	○	○	—	—	△	G code guidance is a function to display illustration of the contents or movements of the commanded format for the G code currently under editing. This is used when creating or editing a machining program.
10	Cyclic error compensation	△	△	△	△	○	○	○	—	—	—	
11	Spatial error compensation	—	—	—	—	—	—	—	—	—	—	This function allows you to import a DXF drawing file from an external I/O device through DXF data input window, extract the figure element data from the drawing. Extracted data can be set as arbitrary shape data or as hole position data to the cycle being edited using the interactive cycle insertion function.
12	Backlash compensation II	—	—	—	—	—	—	—	—	—	—	

class	Machining center system										C80	General explanation
	M800W		M800S		M80W	M80		E80		—		
	M850W	M830W	M850S	M830S	—	M80 TypeA	M80 TypeB	E80 TypeA	E80 TypeB			
3 High-speed and high-accuracy functions [kBPM; k Block per Minute]												
1 High-speed machining mode												
1	High-speed machining mode I (G05P1) maximum [kBPM]	△33.7	△33.7	△33.7	△33.7	○33.7	○33.7	○16.8	—	—	△33.7	This function runs a machining program that approximates a free curve with fine segments at a high speed.
2	High-speed machining mode II (G05P2) maximum [kBPM]	△168	△168	△168	△168	○67.5	○67.5	○67.5	—	—	△67.5	
2 High-accuracy control												
1	High-accuracy control (G61.1 / G08)	△	△	△	△	○	○	○	○	—	△	Machining errors caused by delays in control systems can be inhibited. This function is useful for machining which needs to make an edge at a corner or reduce an error from an inner route of curved shape.
2	Multi-part system simultaneous high-accuracy control	△	△	△	△	—	—	—	—	—	—	
3	SSS control	△	△	△	△	○	○	○	—*	—*	—	High-accuracy control and high-speed machining mode are available respectively in all part systems. The simultaneous usage of high-accuracy control and high-speed machining mode (including High-speed high-accuracy control I/II/III) are available only in part systems which are limited by the parameter. * Up to 2 part systems
4	Tolerance control	△	△	△	△	○	○	○	○	○	—	
5	Variable-acceleration pre-interpolation acceleration / deceleration	—	—	—	—	—	—	—	—	—	—	With SSS (Super Smooth Surface) control, the large area path information is used instead of just the angle between the blocks. Thus, optimum speed control that is not adversely affected by minute steps or waviness is possible. This enables machining with a fewer scratches and streaks on the cutting surface compared to the normal high-accuracy control function. Multiple part systems simultaneous high-accuracy function is required to conduct the SSS control in the second or following part systems. * eSSS (There are limitations on the setting of some parameters.)
6	High-accuracy acceleration / deceleration time constant extension	—	—	—	—	—	—	—	—	—	—	
7	Axis-specific acceleration tolerance control	△	△	△	△	—	—	—	—	—	—	This function enables the smooth operation within the tolerance error range. The desired machining result can be obtained with simple parameter adjustment.
3 High-speed high-accuracy control												
1	High-speed high-accuracy control I (G05.1Q1) maximum [kBPM]	△67.5	△67.5	△67.5	△67.5	○33.7	○33.7	○33.7	—	—	△33.7	This function can perform the acceleration / deceleration during SSS control by setting diverse acceleration to each axis. Therefore, the acceleration for the axis with high responsiveness can be larger than before so that cycle time can be reduced especially in the indexing machining.
2	High-speed high-accuracy control II (G05P10000) maximum [kBPM]	△168	△168	△168	△168	○67.5	○67.5	○67.5	—	—	△67.5	
3	High-speed high-accuracy control III (G05P20000) maximum [kBPM]	—	—	—	—	—	—	—	—	—	—	This extends the upper limit of cutting feed time constant from 5,000[ms] to 30,000[ms] for acceleration/deceleration before interpolation. * 1st part system only
4	Smooth fairing	—	—	—	—	—	—	—	—	—	—	
4	Machining condition selection I	○	○	○	○	○	○	○	○	○	○	The acceleration to be generated at a seam between blocks is evaluated for each axis to control deceleration so that the seam is passed at the optimum speed. This enables highly accurate edge machining. * 1st part system only
5	Direct command mode	△	△	△	△	—	—	—	—	—	—	
4 Programming support functions												
1	Playback	△	△	△	△	—	—	—	—	—	—	A machining program that approximates a free curve with fine segments can be run at a high speed and with a high accuracy. This function is effective in decreasing the cycle time of machining dies with free curves. This function is also useful in machining which needs to make an edge at a corner or reduce a path error from inner route of curved shape because the high-accuracy control mode is turned ON automatically.
3	Interactive cycle insertion	△	△	△	△	○	○	○	○	○	—	
4	Simple programming (NAVI MILL / LATHE)	△	△	△	△	○	○	○	○	○	—	A path can be smoother by compensating commanded positions of a machining program. This function is useful when executing a fine segment program to machine smoothly at low speed or a rough machining program with long segment to machine smoothly.
5	G code guidance	○	○	○	○	○	○	○	○	○	○	
7	DXF data input	△	△	△	△	○	○	—	—	—	—	The machining condition parameter set which consists of parameters related to the high-accuracy control can be configured in advance for each machining application (such as part machining or die machining) or machining process (such as rough or finishing), and it can be switched according to the purpose.
13 Machine accuracy compensation												
1 Static accuracy compensation												
1	Backlash compensation	○	○	○	○	○	○	○	○	○	○	By reducing the load applied during the NC program analysis and interpolation to the minimum possible level, the machining programs expressed in fine segments are executed at a high processing speed.
2	Memory-type pitch error compensation [sets]	○32	○32	○32	○32	○16	○16	○16	○16	○16	○10	
3	Memory-type relative position error compensation	○	○	○	○	○	○	○	○	○	○	This function enables creation of a program while proceeding with simple machining by manual (handle or job) feed or mechanical handle feed.
4	External machine coordinate system compensation	△	△	△	△	○	○	○	○	○	△	
5	Circular radius error compensation	△	△	△	△	○	○	○	—	—	△	This function enables to interactively insert a cycle to assist in the machining and setup for the program opening on the edit screen. The cycle can easily be inserted by editing data in an interactive window.
6	Ball screw thermal expansion compensation	△	△	△	△	○	○	○	○	○	△	
7	Rotation center error compensation	△	△	△	△	—	—	—	—	—	—	Create a part program by using NAVI MILL (for machining center system) or NAVI LATHE (for lathe system).
8	Position-dependent gradually increasing-type backlash compensation	△	△	△	△	○	○	○	—	—	△	
9	Bidirectional pitch error compensation	△	△	△	△	○	○	○	—	—	△	G code guidance is a function to display illustration of the contents or movements of the commanded format for the G code currently under editing. This is used when creating or editing a machining program.
10	Cyclic error compensation	△	△	△	△	○	○	○	—	—	—	
11	Spatial error compensation	—	—	—	—	—	—	—	—	—	—	This function allows you to import a DXF drawing file from an external I/O device through DXF data input window, extract the figure element data from the drawing. Extracted data can be set as arbitrary shape data or as hole position data to the cycle being edited using the interactive cycle insertion function.
12	Backlash compensation II	—	—	—	—	—	—	—	—	—	—	

○Standard △Optional □Selection Specifications of separated-type display are classified with "Windows-based" and non-Windows-based

[M800/M80/E80]S/W ver.F2 [C80]S/W ver.B7

class	Lathe system										C80
	M800W		M800S		M80W	M80		E80		—	
	M850W	M830W	M850S	M830S	—	M80 TypeA	M80 TypeB	E80 TypeA	E80 TypeB		
4	△	△	△	△	○	○	—	—	—	—	—
5	○/—	○/—	—	—	○/—	—	—	—	—	—	—
6	—	—	—	—	—	—	—	—	—	—	○
7	□	□	□	□	□	□	□	□	□	□	—
15 Safety and maintenance											
1 Safety switches											
1	○	○	○	○	○	○	○	○	○	○	○
2	○	○	○	○	○	○	○	○	○	○	○
2 Display for ensuring safety											
1	○	○	○	○	○	○	○	○	○	○	○
2	○	○	○	○	○	○	○	○	○	○	○
3	○	○	○	○	○	○	○	○	○	○	○
4	○	○	○	○	○	○	○	○	○	○	○
5	○	○	○	○	○	○	○	○	○	○	○
6	○	○	○	○	○	○	○	○	○	○	○
3 Protection											
1	○	○	○	○	○	○	○	○	○	○	○
2 Stored stroke limit											
1	○	○	○	○	○	○	○	○	○	○	○
2	△	△	△	△	○	○	○	—	—	—	△
3	△	△	△	△	○	○	○	—	—	—	△
4	△	△	△	△	○	○	○	—	—	—	△
3	△	△	△	△	○	○	○	—	—	—	—
4	○	○	○	○	○	○	○	○	○	○	○
5	○	○	○	○	○	○	○	○	○	○	○
6	○	○	○	○	○	○	○	○	○	○	○
7	△	△	△	△	—	—	—	—	—	—	—
8	—	—	—	—	—	—	—	—	—	—	—
9 Door interlock											
1	○	○	○	○	○	○	○	○	○	○	○
2	○	○	○	○	○	○	○	○	○	○	○
10	○	○	○	○	○	○	○	○	○	○	○
11	○	○	○	○	○	○	○	○	○	○	○
12	○	○	○	○	○	○	○	○	○	○	○
13	△	△	△	△	○	○	○	○	○	○	△
15	○	○	○	○	○	○	○	○	○	○	○
16	△	△	△	△	○	○	○	—	—	—	△
17	○	○	○	○	○	○	—	—	—	—	—
18	○	○	○	○	○	○	○	—	—	—	—
4 Maintenance and troubleshooting											
1	○	○	○	○	○	○	○	○	○	○	○
2	○	○	○	○	○	○	○	○	○	○	○
3	○	○	○	○	○	○	○	○	○	○	○
4 Servo tuning support											
1	○	○	○	○	○	○	○	○	○	○	○
5	○	○	○	○	○	○	○	○	○	○	○(GOT)

(Note 1) The software sold separately is necessary.

class	Machining center system										C80	General explanation
	M800W		M800S		M80W	M80		E80		—		
	M850W	M830W	M850S	M830S	—	M80 TypeA	M80 TypeB	E80 TypeA	E80 TypeB			
△	△	△	△	○	○	—	—	—	—	—	—	This function aims at detecting tool wear or degradation by detecting and monitoring the actual load (current value) on spindle and NC axes on a real time basis.
○/—	○/—	—	—	○/—	—	—	—	—	—	—	—	This function turns the power supply ON / OFF, synchronizing the NC control unit and the HMI screen.
—	—	—	—	—	—	—	—	—	—	—	○	A current limit is available for the PLC axis as well as for the NC axis. This function can be used for actions such as stopper operation.
□	□	□	□	□	□	□	□	□	□	□	—	This function enables a robot to be connected to and directly operated by an NC.
1 Safety switches												
○	○	○	○	○	○	○	○	○	○	○	○	All operations are stopped by the emergency stop signal input and, at the same time, the drive section is stopped and the movement of the machine is stopped.
○	○	○	○	○	○	○	○	○	○	○	○	With the input from the user PLC, it is possible to prohibit the parameter setting or deletion, and the program edit from the setting and display unit.
2 Warnings												
○	○	○	○	○	○	○	○	○	○	○	○	Warnings are output by the CNC system. When one of these warnings occurs, a warning number is output to the PLC and a description of the warning appears on the screen. Operation can be continued without taking further action.
○	○	○	○	○	○	○	○	○	○	○	○	When an alarm has occurred, an alarm number is output to the PLC, and a description of the alarm appears on the screen. Operation cannot be continued without taking remedial action.
○	○	○	○	○	○	○	○	○	○	○	○	The stop cause of automatic operation is shown on the display.
○	○	○	○	○	○	○	○	○	○	○	○	When the "EMG" (emergency stop) message is displayed in the operation status area of the display, the cause of the emergency stop can be confirmed.
○	○	○	○	○	○	○	○	○	○	○	○	When overheating is detected in the control unit, an overheat signal is output at the same time as the alarm is displayed.
○	○	○	○	○	○	○	○	○	○	○	○	When it is time to change the batteries, an alarm and warning are displayed.
3 Protection												
○	○	○	○	○	○	○	○	○	○	○	○	Limit switches and dogs are attached to the machine, and when a limit switch has kicked a dog, the movement of the machine is stopped by the signal input from the limit switch.
4 Prohibited areas												
△	△	△	△	○	○	○	○	—	—	—	△	The areas where tool entry is prohibited can be set with parameters or program commands. There are multiple types of prohibitions according to the prohibited range and method.
△	△	△	△	○	○	○	○	—	—	—	△	By commanding, from the program, the boundary for prohibiting machine entry as a coordinate position in the machine coordinate system, entry into the inner side of that boundary can be prohibited.
—	—	—	—	—	—	—	—	—	—	—	—	By limiting the tool nose point movement range, this function prevents the tool from colliding with the chuck or tail stock because of a programming error.
○	○	○	○	○	○	○	○	○	○	○	○	The machine movement will decelerate and stop as soon as the interlock signal, serving as the external input, is turned ON. When the interlock signal is turned OFF, the machine starts moving again.
○	○	○	○	○	○	○	○	○	○	○	○	This function reduces the feedrate to the deceleration speed set by the parameter when the external deceleration input signal has been set to ON.
△	△	△	△	—	—	—	—	—	—	—	—	By checking the relative relation between interference objects, the interference can be prevented from occurring. One interference object is defined by one to sixteen tridimensional objects. The maximum definable number is 128 for the interference objects and is 256 for the tridimensional objects.
△	△	—	—	—	—	—	—	—	—	—	—	The machine pre-reads the position to be moved during the operation to check the interference by the 3D model (machine, tool and jig) registered in advance. When an interference is predicted, an alarm will be shown immediately and all the axes will be decelerated to stop.
5 CE marking												
○	○	○	○	○	○	○	○	○	○	○	○	Under the CE marking scheme of the European safety standards (machine directive), the opening of any protection doors while a machine is moving is prohibited. When the door open signal is input from the PLC, this function first decelerates, stops all the control axes, establishes the ready OFF status, and then shuts off the drive power inside the servo drive units so that the motors are no longer driven.
○	○	○	○	○	○	○	○	○	○	○	○	This function is used to prohibit the changing of machine parameters.
○	○	○	○	○	○	○	○	○	○	○	○	The edit lock function B or C inhibits machining program B or C (group by machining program numbers) from being edited or erased when these programs require protection.
○	○	○	○	○	○	○	○	○	○	○	○	This function allows the display of only a target program (label address 9000) to be disabled for the program display in the monitor screen, etc.
△	△	△	△	○	○	○	○	○	○	○	△	Up to 8 levels of access permission helps to prevent you from dispatching defective works.
○	○	○	○	○	○	○	○	○	○	○	○	This function prevents the tool from breakage, through pulling up the cutting tool during emergency stop or instantaneous power interruption at low cutting speed.
△	△	△	△	○	○	○	○	—	—	—	△	When an alarm occurs for an axis, this function performs an alarm stop only for the axes in a machine group to which the axis belongs.
—	—	—	—	—	—	—	—	—	—	—	—	This function checks the relative position of up to six cuboids (referred to as interfering objects) all the time, and if a command which causes the interfering objects to collide with each other is issued, the function stops the axis movement to prevent the interference in advance. Such interference can be prevented by covering the tool post, etc. with cuboids. * Up to 4 part systems.
○	○	○	○	○	○	○	○	—	—	—	—	This function consists of a function of calculating the equivalent load ratio of spindle motor and a function of outputting the equivalent load ratio and temperature of spindle motor to the log file.
6 Maintenance and troubleshooting												
○	○	○	○	○	○	○	○	○	○	○	○	This is a maintenance function which is useful for tracing down the history and NC operation information and analyzing problems, etc. This information is saved in the history data file, and can be displayed on the screen and output to a file.
○	○	○	○	○	○	○	○	○	○	○	○	The NC data sampling function samples the NC internal data (speed output from NC to drive unit, and feedback data from the drive unit, etc.). This data can be output as text data.
○	○	○	○	○	○	○	○	○	○	○	○	The NC data back up function backs up the NC parameters, etc., on a built-in disk of display unit or SD card. The data can also be restored.
7 Servo tuning support												
○	○	○	○	○	○	○	○	○	○	○	○	With this function, the servo parameters can be automatically adjusted by connecting the CNC and NC Analyzer2, which is an application that runs on a regular personal computer.
○	○	○	○	○	○	○	○	○	○	○	○(GOT)	With this function, system data, ladder program and custom software can be automatically backed up in case of system failure.

○Standard △Optional □Selection Specifications of separated-type display are classified with "Windows-based" and non-Windows-based

[M800/M80/E80]S/W ver.F2 [C80]S/W ver.B7

Table for Lathe system specifications. Columns include class, M800W, M800S, M80W, M80 (Type A/B), E80 (Type A/B), and C80. Rows cover application error detection, email notifications, diagnostics, backup, and various functional safety features like SLS, SLP, SOS, SSM, SBC, SCA, SS1/SS2, STO, and SCN.

Table for Machining center system specifications. Columns include M800W, M800S, M80W, M80 (Type A/B), E80 (Type A/B), and C80. Rows cover application error detection, email notifications, diagnostics, backup, and various functional safety features like SLS, SLP, SOS, SSM, SBC, SCA, SS1/SS2, STO, and SCN.

(Note 2) Please contact us to purchase a full function version. A limited function version is also available free of charge.

An exclusive sequence program that controls various signals between the controller and the machine to realize the operations applicable to each machine can be created and built in.

○Standard △Optional □Selection Specifications of separated-type display are classified with "Windows-based" and non-Windows-based

[M800/M80/E80]S/W ver.F2 [C80]S/W ver.B7

class	Lathe system										General explanation
	M800W		M800S		M80W	M80		E80		C80	
	M850W	M830W	M850S	M830S	—	M80 TypeA	M80 TypeB	E80 TypeA	E80 TypeB	—	
2	PLC functions										
1	Built-in PLC basic function										△ (MELSEC)
1	Index modification										△ (MELSEC)
2	Multi-program [number of programs]										△ (MELSEC)
3	Multi-project [number of projects stored]										
	Number of PLC projects: 2										—
	Number of PLC projects: 3										—
	Number of PLC projects: 6										—
4	Function block (FB)										△ (MELSEC)
5	Label programming										△ (MELSEC)
2	PLC exclusive instruction										△ (MELSEC)
3	Enhanced PLC security mode										—
3	PLC support functions										
1	Alarm message display										—
2	Operator message display										○*
3	Memory switch (PLC switch)										
1	Memory switch (PLC switch) 32 points										—
2	Memory switch (PLC switch) 64 points										—
3	Memory switch (PLC switch) 96 points										—
4	Load meter display										○
5	User PLC version display										○
6	Ladder program writing during RUN										△ (MELSEC)
7	PLC program protection										△ (MELSEC)
4	Built-in PLC capacity										
1	Standard PLC capacity [number of steps]										△ (MELSEC)
2	Large PLC capacity: 256K steps										—
3	Large PLC capacity: 512K steps										—
5	Machine contact input / output I/F										△ (MELSEC)
6	Ladder monitor										○(GOT)
7	PLC development										
1	On-board development										○(GOT)
2	MELSEC development tool (GX Developer)										—
3	MELSEC development tool (GX Works2) (Note 1)										—
4	MELSEC development tool (GX Works3) (Note 1)										○
8	PLC parameter										
1	PLC constant (150 points)										○
2	PLC constant extension (Up to 750 points)										—
9	GOT connection										
1	Ethernet connection										○
2	CC-Link connection										△ (MELSEC)
3	CC-Link IE field network connection										△ (MELSEC)
10	Pallet program registration										—
2	Machine construction										
1	Servo OFF										○
2	Axis detachment										○

class	Machining center system										General explanation
	M800W		M800S		M80W	M80		E80		C80	
	M850W	M830W	M850S	M830S	—	M80 TypeA	M80 TypeB	E80 TypeA	E80 TypeB	—	
	○	○	○	○	○	○	○	○	○	△ (MELSEC)	[M800/M80/E80] Basic commands (bit processing commands): LD, LDI, OR, ORI, AND, ANI, OUT, PLS, etc. Function commands: Data transfer, 4 basic arithmetic operations, logic arithmetic operations, large/small identification, binary/BCD conversion, branching, conditional branching, decoding, encoding, etc. [C80] For the details, refer to the manual of MITSUBISHI Programmable Controller "MELSEC IQ-R series".
	○	○	○	○	○	○	○	○	○	△ (MELSEC)	
	○120	○120	○120	○120	○60	○60	○60	○60	○60	△ (MELSEC)	
	○	○	○	○	—	—	○	○	○	—	
	△	△	△	△	○	○	—	—	—	—	
	△	△	△	△	—	—	—	—	—	—	
	○	○	○	○	○	○	○	○	○	△ (MELSEC)	
	○	○	○	○	○	○	○	○	○	△ (MELSEC)	
	○	○	○	○	○	○	○	○	○	△ (MELSEC)	
	○	○	○	○	○	○	○	○	○	△ (MELSEC)	
	○	○	○	○	○	○	○	○	○	△ (MELSEC)	PLC-dedicated instruction is provided for some limited applications, enabling a complex machining process, which is difficult to carry out only by the basic instructions and function instructions. This function restricts connections to the built-in PLC from applications such as PLC on-board and GX Developer/GX Works2.
	○	○	○	○	○	○	○	○	○	—	The contents of the alarms which have occurred during sequence (user PLC) processing can be displayed on the setting and display unit. When some conditions occur where you wish to inform a messages to the operator, an operator message can be displayed separately from the alarm message. * Only the macro alarm message can be displayed.
	○	○	○	○	○	○	○	○	○	○*	
	○	○	○	○	○	○	○	○	○	○	PLC switches can be set on the setting and display unit screen, and the ON / OFF control executed.
	○	○	○	○	○	○	○	○	○	○	A load meter can be displayed on the setting and display unit.
	○	○	○	○	○	○	○	○	○	○	The user PLC version can be displayed in the software list on the Software Configuration screen.
	○	○	○	○	○	○	○	○	○	○	Ladder program can be edited while PLC is running. This function is available, either by GX Developer or PLC onboard edit.
	○	○	○	○	○	○	○	○	○	△ (MELSEC)	[M800/M80/E80] For PLC data protection, the file password can be set to each file of PLC data. [C80] For the details, refer to the manual of MITSUBISHI Programmable Controller "MELSEC IQ-R series".
	○128K	○128K	○128K	○128K	○64K	○64K	○32K	○20K	○20K	△ (MELSEC)	[M800/M80/E80] In the program memory, it is possible to store the system area of parameters, intelligent function module parameters, sequence programs, device comments, and device initial values. [C80] For the details, refer to the manual of MITSUBISHI Programmable Controller "MELSEC IQ-R series".
	○	○	○	○	○	○	○	○	○	○	[M800/M80/E80] The operation panel I/O unit or the remote I/O unit is selected based on the types of input signals (sink/source) or output signals (source) available for input or output and the number of contacts required. [C80] The device is selected from the I/O modules of the MITSUBISHI Programmable Controller "MELSEC IQ-R Series".
	○	○	○	○	○	○	○	○	○	○	[M800/M80/E80] This function enables the operating status of the sequence circuit to be checked on the controller's setting and display unit. [C80] This function enables to display on GOT the operating status of the sequence circuit to be checked. "Sequence program monitor" (GOT2000) is used.
	○	○	○	○	○	○	○	○	○	○	On-board refers generically to the PLC related operations carried out with the CNC unit. The Mitsubishi CNC on-board realizes functions and operations similar to the MELSEC Series ladder development tool (GX Developer).
	○	○	○	○	○	○	○	○	○	○	This function enables the data of the PLC contained inside the NC system to be developed and debugged using the GX Developer.
	○	○	○	○	○	○	○	○	○	○	This function enables the data of the PLC contained inside the NC system to be developed and debugged using the GX Works2.
	—	—	—	—	—	—	—	—	—	○	Using GX Works3, the sequence programs of the MELSEC CPU can be developed and debugged.
	○	○	○	○	○	○	○	○	○	○	The PLC constants set with the data type, and the bit selection parameters set with the bit types can be specified on the screen as the parameters to use in the built-in PLC.
	○	○	○	○	○	○	○	○	○	○	For connecting a MITSUBISHI Graphic Operation Terminal (GOT), refer to the GOT Catalogs.
	△	△	△	△	—	—	—	—	—	—	Pallet program function assists the machining setups as it allows machining programs to be registered for each pallet of the auto pallet changer.
	○	○	○	○	○	○	○	○	○	○	When the servo OFF signal (per axis) is input, the corresponding axis is set in the servo OFF state. When the moving axis is mechanically clamped, this function is designed to prevent the servo motor from being overloaded by the clamping force.
	○	○	○	○	○	○	○	○	○	○	This function enables the control axis to be released from control.

(Note 1) The software sold separately is necessary.

○Standard △Optional □Selection Specifications of separated-type display are classified with "Windows-based" and non-Windows-based

[M800/M80/E80]S/W ver.F2 [C80]S/W ver.B7

class	Lathe system										C80
	M800W		M800S		M80W	M80		E80		—	
	M850W	M830W	M850S	M830S	—	M80 TypeA	M80 TypeB	E80 TypeA	E80 TypeB		
3	△	△	△	△	○	○	○	—	—	△	
4	△	△	△	△	○	○	○	○	○	△	
5	○24	○24	○24	○24	○24	○24	○24	○24	○24	○*	
7	○	○	○	○	○	○	○	○	○	○	
8	△*	△*	△*	△*	—	—	—	—	—	—	
9	—	—	—	—	—	—	—	—	—	—	
10	—	—	—	—	—	—	—	—	—	—	
11	—	—	—	—	—	—	—	—	—	—	
12	△	△	△	△	○	○	—	—	—	—	
13	△	△	△	△	○	○	○	○	—	—	
14	△*	△*	△*	△*	—	—	—	—	—	—	
15	△*	—	△*	—	—	—	—	—	—	—	
16	△	△	△	△	○	○	—	—	—	—	
17	—	—	—	—	—	—	—	—	—	—	
18	—	—	—	—	—	—	—	—	—	—	
20	Real-time tuning										
1	△	△	△	△	○	○	—	—	—	—	
2	△	△	△	△	○	○	—	—	—	—	
21	△	△	△	△	○	○	○	○	○	—	
22	○	○	○	○	○	○	○	○	○	—	
23	—	—	—	—	—	—	—	—	—	—	
3 PLC operation											
1	○	○	○	○	○	○	○	○	○	○	
2	△	△	△	△	○	○	○	—	—	—	
3	○	○	○	○	○	○	○	○	○	○	
5	○	○	○	○	○	○	○	○	○	○	
6	△	△	△	△	○	○	○	—	—	△	
4 PLC interface											
1	○	○	○	○	○	○	○	○	○	○	
2	○	○	○	○	○	○	○	○	○	○	
3	○	○	○	○	○	○	○	○	○	○	

class	Machining center system										General explanation
	M800W		M800S		M80W	M80		E80		C80	
	M850W	M830W	M850S	M830S	—	M80 TypeA	M80 TypeB	E80 TypeA	E80 TypeB		
△	△	△	△	○	○	○	—	—	△	The synchronous control is a control method whereby both master and slave axes are controlled with the same travel command by designating the travel command for the master axis also to the slave axis. This function is assumed to be used in such equipment as large machine tools, which drive one axis with two servo motors.	
△	△	△	△	○	○	○	—	—	—	Even when the control axes in a machine are mounted at an angle other than 90 degrees, this function enables it to be programmed and controlled in the same way as with an orthogonal axis.	
○24	○24	○24	○24	○24	○24	○24	○24	○24	○24	○*	Instead of a dog switch on a machine's axis, a hypothetical dog switch is established using a parameter to set a coordinate position to show the axis name and the hypothetical dog position. When the machine reaches the position, a signal is output to the PLC interface. * 24 points for each part system and 32 points for the whole PLC axes.
○	○	○	○	○	○	○	○	○	○	○	The indexing of the index table can be performed by setting the index axes. (1) Changing the tool length compensation along the tool axis and compensation amount Even if the tool axis direction is not the Z axis direction because the rotary axis is rotated, the tool can be compensated in the tool axis direction. (2) Machine configuration The tool length compensation along the tool axis is carried out in respect to the direction of the tool nose axis (rotary axis). * This function is available during program format switch for L system.
△	△	△	△	—	—	—	—	—	—	—	This function makes it possible to move the axis with the manual pulse generator in the tool axis direction, tool diameter direction X and tool diameter direction Y in the hypothetical coordinate system over the tool axis.
△	△	△	△	—	—	—	—	—	—	—	The tool center coordinates, handle interrupt amount (tool axis movement) and tool center point speed are displayed during the tool center point control function, tool length compensation along the tool axis function, and tool handle feed & interrupt function (tool axis direction handle feed, tool handle interrupt, tool diameter direction handle feed, nose center rotation handle feed).
△	△*	△	△*	○*	○*	—	—	—	—	—	This function controls so that the position command in a machining program is at the tool center point in the coordinate system (table coordinate system) which rotates together with the workpiece. * Restrained to 4-axis simultaneous contouring for M830/M80W/M80A
△	△	△	△	○	○	—	—	—	—	△	An arbitrary spatial plane defined with this function can be machined using normal program commands. * This includes simple tool center point control. This function is used when a lathe with the orthogonal axes XYZ and the turret with B axis performs the milling on the inclined surface in the end face direction. This allows the operator to perform cutting on an inclined surface with no need for considering the inclination angle.
△	△	△	△	—	—	—	—	—	—	—	This function is to compensate the tool radius of the 5-axis machine with two rotary axes, in accordance with the change of the workpiece direction and inclination of the tool due to the movement of the rotary axis. * This function is available during program format switch for L system.
△	—	△	—	—	—	—	—	—	—	—	This function is used for a 5-axis machine. This compensates the error when a workpiece is placed off the workpiece coordinate system to enable machining according to the program. * This function is available during program format switch for L system.
△	△	△	△	○	○	—	—	—	—	△	By selecting the hypothetical coordinate system to be machined, axis can be moved with manual feed (JOG, HANDLE or INCREMENTAL) in the coordinate system with this function. It can be easy to setup because multiple axes is moved by NC according to the tool angle or the inclination of the table.
△	△	△	△	○	○	—	—	—	—	—	This provides easy setup of index machining (multiple/inclined surface machining) using a rotary axis.
△	△	△	△	○	○	—	—	—	—	—	This function enables an axis to be synchronized with the axis previously defined as master axis for the synchronous control, and another axis to be synchronized with the slave axis.
△	△	△	△	○	○	—	—	—	—	—	This function estimates the inertia (or workpiece weight) of mechanical system and changes the speed control gain automatically according to the estimation results to suppress mechanical vibration. Users can expect suppression of vibration caused by inertia fluctuation, as well as reduction of machining time through adaptation of appropriate speed control gain.
△	△	△	△	○	○	—	—	—	—	—	This function estimates the inertia (or workpiece weight) of mechanical system and optimizes the acceleration/deceleration time constant automatically according to the estimation results. It achieves the cycle time reduction when the inertia of workpiece to machine changes significantly.
△	△	△	△	○	○	○	○	○	○	—	The servo motor of the axis designated for [Constant torque control] outputs the torque set by the parameter in a constant direction. The servo motor of the axis designated for [Proportional torque stopper control] generates the torque set by the parameter in the stopper direction.
○	○	○	○	○	○	○	○	○	○	—	This function outputs the position (angle) of external encoder to PLC device based on the input pulses from the encoder. This function can be used to monitor the position of angular head which the external encoder is connected to. * Encoder expansion card is required for M800W/M80W
△	△	△	△	○	○	○	○	○	—	—	Multiple-axis synchronization control is the function that enables multiple slave axes to be synchronized with commands to the master axis.
○	○	○	○	○	○	○	○	○	○	○	This is a function to control the NC control axis with command from the PLC in addition to the normal automatic operation command on the NC.
△	△	△	△	○	○	○	—	—	—	—	By specifying a hypothetical coordinate on the machine coordinate from the user PLC, oblique linear interpolation or circular interpolation is executed with jog / handle feed, manual rapid traverse or incremental feed of either X axis or Y axis.
○	○	○	○	○	○	○	○	○	—	○	This function allows independent axes to be controlled with PLC-based commands, separately from the NC control axes.
○	○	○	○	○	○	○	○	○	—	○	PLC axis indexing allows a PLC axis to function as an auxiliary axis with no need for changing the user ladder used conventionally for an auxiliary axis.
△	△	△	△	○	○	○	—	—	—	△	This function is to use one drive unit by switching the control from the NC or the PLC dynamically. The function of the NC axis can be used during the NC axis control and the function of the PLC axis can be used during the PLC axis control respectively.
○	○	○	○	○	○	○	○	○	○	○	Control commands to the CNC system are assigned from the PLC. Input signals with skip inputs that respond at high speed can also be used.
○	○	○	○	○	○	○	○	○	○	○	The status signals are output from the CNC system. They can be utilized by referencing them from the PLC.
○	○	○	○	○	○	○	○	○	○	○	[M800/M80/E80] This function uses the "read window" or "write window" assigned to the R register's user area to read and write the CNC operation status, axis information, parameters and tool data, etc. [C80] This function uses the "read window" or "write window" to read and write the CNC operation status, axis information, parameters and tool data, etc.

○Standard △Optional □Selection Specifications of separated-type display are classified with "Windows-based" and non-Windows-based

[M800/M80/E80]S/W ver.F2 [C80]S/W ver.B7

class	Lathe system									
	M800W		M800S		M80W	M80		E80		C80
	M850W	M830W	M850S	M830S	—	M80 TypeA	M80 TypeB	E80 TypeA	E80 TypeB	—
4 External search	○	○	○	○	○	○	○	○	○	○
5 Direct Screen Selection	○	○	○	○	○	○	○	○	○	○
6 Buzzer sound control	○	○	○	○	○	○	○	○	○	—
5 Machine contact I/O										
1 Operation Panel I/O										
1 DI:64 / DO:64	□/—	□/—	—	—	□/—	—	—	□	□	—
2 DI:64 / DO:64+SDI:8	□/—	□/—	—	—	□/—	—	—	□	□	—
3 DI:96 / DO:64	—/□	—/□	□	□	—/□	□	□	□	□	—
5 DI:64 / DO:48 / AO:1	—/□	—/□	□	□	—/□	□	□	□	□	—
2 Remote I/O										
1 DI:32 / DO:32	□	□	□	□	□	□	□	□	□	—
2 DI:64 / DO:48	□	□	□	□	□	□	□	□	□	—
3 DI:64 / DO:48+AO:1	□	□	□	□	□	□	□	□	□	—
5 DI:16 / DO:8	□	□	□	□	□	□	□	□	□	—
6 DI:32 / DO:32+SDI:8 / SDO:4	□	□	□	□	□	□	□	□	□	—
7 SDI:8 / SDO:4	□	□	□	□	□	□	□	□	□	—
6 External PLC link										
1 CC-Link (Master / Local)	□	□	□	□	□	□	□	□	□	△ (MELSEC)
2 PROFIBUS-DP (Master)	□	□	□	□	□	□	□	□	□	—
3 CC-Link IE Field network (Master / Local)	□	□	□	□	□	□	□	□	□	△ (MELSEC)
5 EtherNet/IP	□	□	□	□	□	□	□	□	□	—
8 FL-net	□	□	□	□	□	□	□	□	□	△ (MELSEC)
10 CC-Link IE Field Basic	○	○	○	○	○	○	○	○	○	—
7 Installing S/W for machine tools										
1 Customization(NC Designer2) (Note 1)	○	○	○	○	○	○	○	○	○	—
1 Customization data storage capacity [MB]	□	□	6	6	□	6	6	1	1	—
2 Customization working memory size [MB]	6	6	6	6	3	3	3	1	1	—
2 User-defined key	○	○	○	○	○	○	○	○	○	—
3 EZSocket I/F (Note 1)	○	○	○	○	○	○	○	○	○	—
4 APLC release (Note 1)	△	△	△	△	○	○	○	○	○	△
5 Custom API library	○	○	○	○	○	○	○	○	○	—
6 MES interface library	△	△	△	△	○	○	○	○	○	—
7 SLMP Server	○	○	○	○	○	○	○	○	○	—
8 Mitsubishi CNC communication software FCSB1224W000 (Note 1)	○	○	○	○	○	○	○	○	○	—
10 GOT2000 screen design tool GT Works3	—	—	—	—	—	—	—	—	—	○
8 Others										
1 System lock	△	△	△	△	○	○	○	○	○	—
2 CNC remote operation tool										
1 NC Monitor2 (Note 1)	○	○	○	○	○	○	○	○	○	○
2 NC Explorer (Note 3)	○	○	○	○	○	○	○	○	○	○
3 Automatic operation lock	○	○	○	○	○	○	○	○	○	○
4 Power consumption computation	○	○	○	○	○	○	○	○	○	○
5 EcoMonitorLight connection	○	○	○	○	○	○	○	○	○	—
6 GOT Window	—	—	—	—	—	—	—	—	—	○
7 Log Viewer	—	—	—	—	—	—	—	—	—	○

(Note 1) The software sold separately is necessary.
(Note 3) This tool is free of charge. Please contact us.

class	Machining center system										General explanation
	M800W		M800S		M80W	M80		E80		C80	
	M850W	M830W	M850S	M830S	—	M80 TypeA	M80 TypeB	E80 TypeA	E80 TypeB	—	
4 External search	○	○	○	○	○	○	○	○	○	○	This function enables searching of the program to automatically start from the PLC. The program No., block No. and sequence No. can be designated. In addition, the details of the search in progress can be read.
5 Direct Screen Selection	○	○	○	○	○	○	○	○	○	○	This signal allows an automatic transition to the alarm display screen when an alarm occurs.
6 Buzzer sound control	○	○	○	○	○	○	○	○	○	○	This function gives a buzzer mounted on the NC keyboard by operating the PLC device. This is effective in applications of sounding a buzzer such as during the alarm occurrence, or for the program operation end notification.
5 Machine contact I/O											
1 Operation Panel I/O											
1 DI:64 / DO:64	□/—	□/—	—	—	□/—	—	—	□	□	—	Some types of signals can be input/output from the operation panel I/O unit according to the type and No. of contacts.
2 DI:64 / DO:64+SDI:8	□/—	□/—	—	—	□/—	—	—	□	□	—	
3 DI:96 / DO:64	—/□	—/□	□	□	—/□	□	□	□	□	—	
5 DI:64 / DO:48 / AO:1	—/□	—/□	□	□	—/□	□	□	□	□	—	
2 Remote I/O											
1 DI:32 / DO:32	□	□	□	□	□	□	□	□	□	—	The remote I/O unit equipped with the maximum number of DI/DO points is the one with 64 points for DI and 48 points for DO. Multiple remote I/O units can be used as long as the total number of occupied stations is 64 or less. * Safety card is required for M80 when using "DI:32/DO:32+SDI:8/SDO:4" or "SDI:8/SDO:4".
2 DI:64 / DO:48	□	□	□	□	□	□	□	□	□	—	
3 DI:64 / DO:48+AO:1	□	□	□	□	□	□	□	□	□	—	
5 DI:16 / DO:8	□	□	□	□	□	□	□	□	□	—	
6 DI:32 / DO:32+SDI:8 / SDO:4	□	□	□	□	□	□	□	□	□	—	
7 SDI:8 / SDO:4	□	□	□	□	□	□	□	□	□	—	
6 External PLC link											
1 CC-Link (Master / Local)	□	□	□	□	□	□	□	□	□	△ (MELSEC)	[M800/M80/E80] NC unit can be directly connected to the network to serve as the master/local station of the MELSEC CC-Link. [C80] Refer to manuals of each unit of MITSUBISHI Programmable Controller "MELSEC IQ-R series" for information on the function and the performance.
2 PROFIBUS-DP (Master)	□	□	□	□	□	□	□	□	□	—	NC can input / output devices to / from slave stations as a master station of PROFIBUS-DP communication by connecting to PROFIBUS-DP-capable slave stations.
3 CC-Link IE Field network (Master / Local)	□	□	□	□	□	□	□	□	□	△ (MELSEC)	Refer to manuals of each unit of MITSUBISHI Programmable Controller "MELSEC IQ-R series" for information on the function and the performance.
5 EtherNet/IP	□	□	□	□	□	□	□	□	□	—	By mounting EtherNet/IP function expansion unit on NC control unit to connect EtherNet/IP-compatible equipment, PLC devices can be input/output using NC control unit as a scanner or an adapter for EtherNet/IP communication.
8 FL-net	□	□	□	□	□	□	□	□	□	△ (MELSEC)	[M800/M80/E80] FL-net communication is available by mounting FL-net expansion unit on the NC control unit. [C80] Refer to manuals of each unit of MITSUBISHI Programmable Controller "MELSEC IQ-R series" for information on the function and the performance.
10 CC-Link IE Field Basic	○	○	○	○	○	○	○	○	○	—	CC-Link IE Field Basic enables periodical data communication (cyclic data transmission) between master station and slave station by connecting the NC controller to CC-Link IE Field Network Basic compatible devices via built-in Ethernet port.
7 Installing S/W for machine tools											
1 Customization(NC Designer2) (Note 1)	○	○	○	○	○	○	○	○	○	—	It is an optional function that allows a user-created screen or window to be displayed as an HMI screen or another application on the screen. * Capacity depends on memory space for M800W/M80W
1 Customization data storage capacity [MB]	□	□	6	6	□	6	6	1	1	—	
2 Customization working memory size [MB]	6	6	6	6	3	3	3	1	1	—	
2 User-defined key	○	○	○	○	○	○	○	○	○	—	This function allows an arbitrary character string to be assigned to a key and makes it easy to input a typical character string.
3 EZSocket I/F (Note 1)	○	○	○	○	○	○	○	○	○	—	This middleware makes it easy to develop applications having the Windows interface.
4 APLC release (Note 1)	△	△	△	△	○	○	○	○	○	△	APLC (Advanced Programmable Logic Controller) release is a function that allows the user-generated C language module to be called from the NC. Control operations that are difficult to express in a sequence program can be created with the C language.
5 Custom API library	○	○	○	○	○	○	○	○	○	—	This function is designed to interface an NC with an application developed by a user. You can set and refer the data for NC using this function. * Please contact us for details.
6 MES interface library	△	△	△	△	○	○	○	○	○	—	The MES interface library function links the NC internal data and the database of information system (manufacturing execution system) without a communication gateway.
7 SLMP Server	○	○	○	○	○	○	○	○	○	—	Transfers data using the SLMP between an NC and an external device. This function enables easy connection with external devices and read/write NC data through the Ethernet cable.
8 Mitsubishi CNC communication software FCSB1224W000 (Note 1)	○	○	○	○	○	○	○	○	○	—	The software designed to help development of an application with Windows interface for Mitsubishi computerized numerical controller. The product can accelerate development by using OLE interface common to computerized numerical controller without knowing internal processing of the machine.
10 GOT2000 screen design tool GT Works3	—	—	—	—	—	—	—	—	—	○	This integrated software is used to create professional screen designs for GOTs.
8 Others											
1 System lock	△	△	△	△	○	○	○	○	○	—	This function locks the operations of the NC if the release code is not entered before the specified time limit.
2 CNC remote operation tool											
1 NC Monitor2 (Note 1)	○	○	○	○	○	○	○	○	○	○	NC Monitor2 is a PC software tool that monitors information in the NC unit connected with the Ethernet.
2 NC Explorer (Note 3)	○	○	○	○	○	○	○	○	○	○	NC Explorer is a software tool to operate the machining data files of each NC unit connected with a host personal computer by Ethernet connection from the Explorer on the host personal computer.
3 Automatic operation lock	○	○	○	○	○	○	○	○	○	○	Automatic operation lock function prevents the falsification of APLC (C language module) by a third party.
4 Power consumption computation	○	○	○	○	○	○	○	○	○	○	Present power consumption and accumulated power consumption can be acquired with this function. The present power consumption notifies the instantaneous power consumption and the accumulated power consumption notifies the integrated value of the present power consumption.
5 EcoMonitorLight connection	○	○	○	○	○	○	○	○	○	—	NC system can collect and manage the electric power of the machine tool which is measured by the energy measuring unit "EcoMonitorLight (sold separately)".
6 GOT Window	—	—	—	—	—	—	—	—	—	○	This is the interface to display the variety of NC data on GOT connected to the CNC CPU.
7 Log Viewer	—	—	—	—	—	—	—	—	—	○	This reads out the running machining program No., the running machining program and the coordinate values, etc. by the device read command. This function enables the recorded data by the data sampling function of the NC to display with a graph on the GOT, and to store the data as a file.

CNC SYSTEM HARDWARE

[mm]

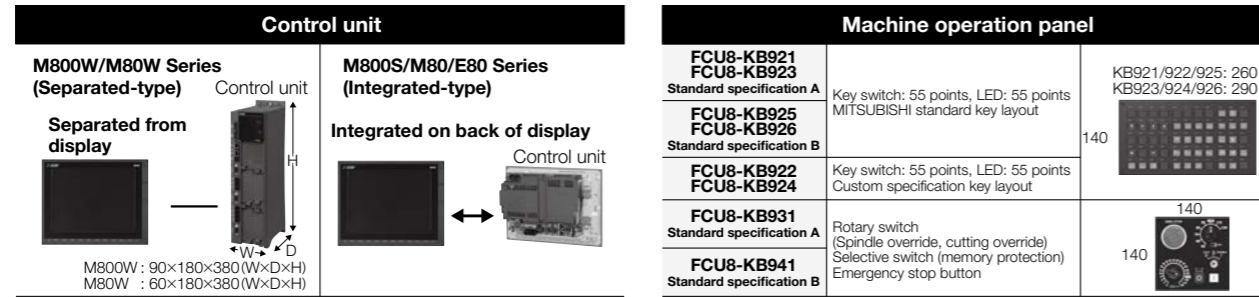

Machine operation panel Key layout

FCU8-KB921/923 (Standard specification A)

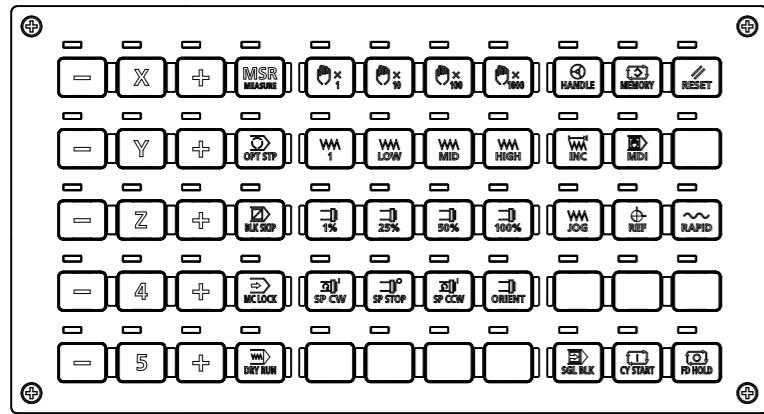

FCU8-KB925/926 (Standard specification B)

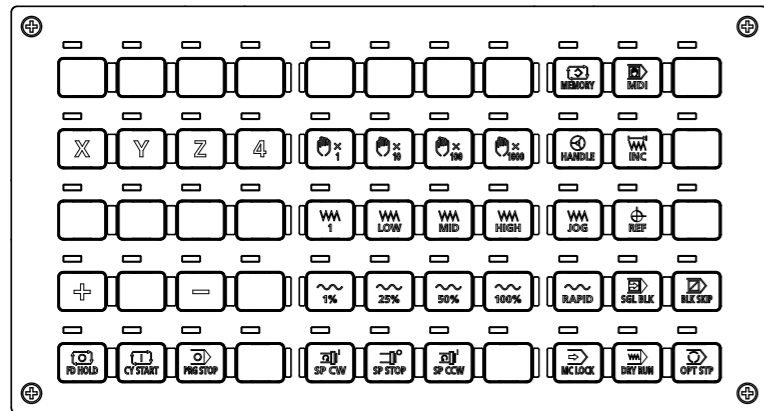

FCU8-KB931 (Standard specification A)

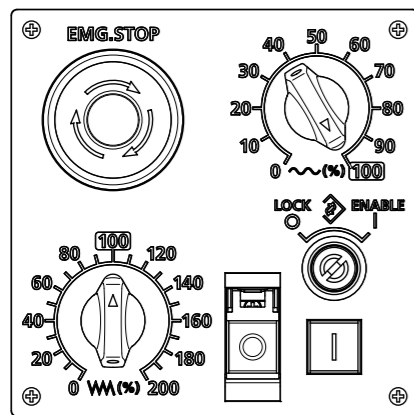

FCU8-KB941 (Standard specification B)

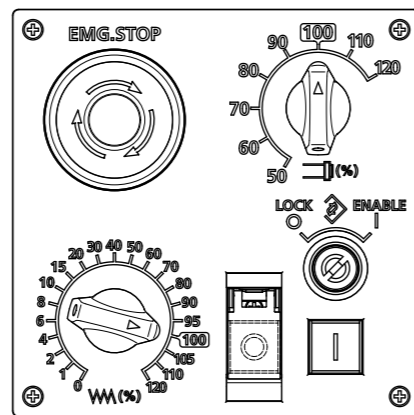

Display	Keyboard	M800W Series	M800S Series	M80W Series	M80 Series	E80 Series
19-type Touchscreen	—	365 440 Windows based	—	365 440 Windows based	—	—
19-type, horizontal Touchscreen	—	440 365 Windows based	—	440 365 Windows based	—	—
15-type Touchscreen	FCU8-KB083 Clear key Full keyboard	400 320 140 Windows-based display can be selected	400 320 140	400 320 140 Windows-based display can be selected	400 320 140	—
10.4-type Touchscreen	FCU8-KB047 Clear key Full keyboard	290 160	290 160	290 160	290 160	—
10.4-type Touchscreen	FCU8-KB041 Clear key ONG(XZF) layout for L system FCU8-KB046 Clear key ONG(XYZ) layout	290 140	290 140	290 140	290 140	—
10.4-type Touchscreen	FCU8-KB048 Clear key ABC layout	290 230	290 230	290 230	290 230	—
8.4-type	FCU8-KB026 Clear key ONG(XYZ) layout FCU8-KB028 Clear key ONG(XZF) layout for L system	—	—	260 140	260 140	—
8.4-type	FCU8-KB029 Clear key ONG layout	—	—	260 140	260 140	—
8.4-type	FCU8-KB025 Sheet keys ONG(XZF) layout for L system FCU8-KB024 Sheet keys ONG(XZF) layout	—	—	—	—	260 140 200

CNC SYSTEM CONTROL UNIT/DISPLAY UNIT

[M800/M80 Series]

■Display unit/control unit separated-type

CNC System

Series	Model name	System type	NC control unit
M800W Series	M850W	FCA850U	FCU8-MA041-001
	M830W	FCA830U	FCU8-MU042-001
M80W Series	M80W	FCA80U	FCU8-MU044-001

Display unit

Classification	Type	Remarks	Supported Series	
			M800	M80W
Windows-based display unit	19-type vertical color LCD touchscreen	FCU8-DU191-75	○	—
		FCU8-DU191-77	—	○
	19-type horizontal color LCD touchscreen	FCU8-DU192-75	○	—
		FCU8-DU192-77	—	○
15-type color LCD touchscreen	FCU8-DU181-34	○	—	
	FCU8-DU181-36	—	○	
non-Windows-based display unit	15-type color LCD touchscreen	FCU8-DU181-31	○	—
		FCU8-DU181-32	—	○
	10.4-type color LCD touchscreen	FCU8-DU141-31	○	—
		FCU8-DU141-32	—	○
8.4-type color LCD	FCU8-DU121-12	—	○	

■Display unit/control unit integrated-type

Series	Model name	System type	NC control unit	Display unit
M800S Series	M850S	FCA850H-8S	FCU8-MA542-001	FCU8-DU181-31 (15-type color LCD touchscreen)
		FCA850H-4S		FCU8-DU141-31 (10.4-type color LCD touchscreen)
	M830S	FCA830H-8S	FCU8-MU542-001	FCU8-DU181-31 (15-type color LCD touchscreen)
		FCA830H-4S		FCU8-DU141-31 (10.4-type color LCD touchscreen)
M80 Series	M80 TypeA	FCA80H-8A	FCU8-MU512-001	FCU8-DU181-32 (15-type color LCD touchscreen)
		FCA80H-4A		FCU8-DU141-32 (10.4-type color LCD touchscreen)
		FCA80P-2A		FCU8-DU121-12 (8.4-type color LCD)
	M80 TypeB	FCA80H-8B	FCU8-MU511-001	FCU8-DU181-32 (15-type color LCD touchscreen)
		FCA80H-4B		FCU8-DU141-32 (10.4-type color LCD touchscreen)
		FCA80P-2B		FCU8-DU121-12 (8.4-type color LCD)
E80 Series	E80 TypeA	FCA80P-2EA	FCU8-MU514-001	FCU8-DU121-13(8.4-type color LCD)
	E80 TypeB	FCA80P-2EB	FCU8-MU513-001	FCU8-DU121-13(8.4-type color LCD)

[C80 Series]

■CNC-CPU unit

Product	Model	Remarks
CNC control module	R16NCCPU-S1	

■GOT2000 related unit

SD card

Product	Model	Model code	Remarks
SD card	NZ1MEM-2GBSD	1WC535	2GB SD memory card for GOT

GT27 Model

Product	Model	Model code	Remarks	
GT27 Model	GT2715	GT2715-XTBA	1EA790	15" XGA [1024×768 dots] TFT color LCD 65536 colors (Multimedia & Video/RGB compliant Multi-touch compliant) 100 to 240VAC, User memory Memory for storage (ROM): 57MB, Memory for operation (RAM): 128MB GT Designer3 Version (GOT2000) 1.117X or later is required.
	GT2712	GT2712-STBA	1EA780	12.1" SVGA [800×600 dots] TFT color LCD 65536 colors (Multimedia & Video / RGB compliant Multi-touch compliant) 100 to 240VAC, User memory Memory for storage (ROM): 57MB, Memory for operation (RAM): 128MB GT Designer3 Version1 (GOT2000) 1.155M or later is required.
		GT2712-STBD	1EA781	12.1" SVGA [800×600 dots] TFT color LCD 65536 colors (Multimedia & Video / RGB compliant Multi-touch compliant) 24VDC, User memory Memory for storage (ROM): 57MB, Memory for operation (RAM): 128MB GT Designer3 Version1 (GOT2000) 1.155M or later is required.
	GT2710	GT2710-STBA	1EA770	10.4" SVGA [800×600 dots] TFT color LCD 65536 colors (Multimedia & Video / RGB compliant Multi-touch compliant) 100 to 240VAC, User memory Memory for storage (ROM): 57MB, Memory for operation (RAM): 128MB GT Designer3 Version1 (GOT2000) 1.155M or later is required.
		GT2710-STBD	1EA771	10.4" SVGA [800×600 dots] TFT color LCD 65536 colors (Multimedia & Video / RGB compliant Multi-touch compliant) 24VDC, User memory Memory for storage (ROM): 57MB, Memory for operation (RAM): 128MB GT Designer3 Version1 (GOT2000) 1.155M or later is required.
	GT2708	GT2708-STBA	1EA740	8.4" SVGA [800×600 dots] TFT color LCD 65536 colors (Multimedia & Video / RGB compliant Multi-touch compliant) 100 to 240VAC, User memory Memory for storage (ROM): 57MB, Memory for operation (RAM): 128MB GT Designer3 Version1 (GOT2000) 1.155M or later is required.
		GT2708-STBD	1EA741	8.4" SVGA [800×600 dots] TFT color LCD 65536 colors (Multimedia & Video / RGB compliant Multi-touch compliant) 24VDC, User memory Memory for storage (ROM): 57MB, Memory for operation (RAM): 128MB GT Designer3 Version1 (GOT2000) 1.155M or later is required.
	GT2710	GT2710-VTBA	1EA760	10.4" VGA [640×480 dots] TFT color LCD 65536 colors (Multimedia & Video / RGB compliant Multi-touch compliant) 100 to 240VAC, User memory Memory for storage (ROM): 57MB, Memory for operation (RAM): 128MB GT Designer3 Version1 (GOT2000) 1.165X or later is required.
		GT2710-VTBD	1EA761	10.4" VGA [640×480 dots] TFT color LCD 65536 colors (Multimedia & Video / RGB compliant Multi-touch compliant) 24VDC, User memory Memory for storage (ROM): 57MB, Memory for operation (RAM): 128MB GT Designer3 Version1 (GOT2000) 1.165X or later is required.
	GT2708	GT2708-VTBA	1EA730	8.4" VGA [640×480 dots] TFT color LCD 65536 colors (Multimedia & Video / RGB compliant Multi-touch compliant) 100 to 240VAC, User memory Memory for storage (ROM): 57MB, Memory for operation (RAM): 128MB GT Designer3 Version1 (GOT2000) 1.165X or later is required.
		GT2708-VTBD	1EA731	8.4" VGA [640×480 dots] TFT color LCD 65536 colors (Multimedia & Video / RGB compliant Multi-touch compliant) 24VDC, User memory Memory for storage (ROM): 57MB, Memory for operation (RAM): 128MB GT Designer3 Version1 (GOT2000) 1.165X or later is required.
	GT2705	GT2705-VTBD	1EA721	5.7" VGA [640×480 dots] TFT color LCD 65536 colors (Multi-touch compliant) 24VDC, User memory Memory for storage (ROM): 32MB, Memory for operation (RAM): 80MB GT Designer3 Version1 (GOT2000) 1.165X or later is required.
	Protective sheet	GT27-15PSCC	1EK313	Surface treatment: anti-glare, Sheet color: transparent, USB environmental protection cover area: open, Number of sheets included in a set: 5
		GT25-12PSCC	1EK307	For 12.1" Clear type, Transparent, With a hole for the USB environmental protection cover, A set of 5 sheets.
GT25-10PSCC		1EK304	For 10.4" Clear type, Transparent, With a hole for the USB environmental protection cover, A set of 5 sheets.	
GT25-08PSCC		1EK301	For 8.4" Clear type, Transparent, With a hole for the USB environmental protection cover, A set of 5 sheets.	
	GT25-05PSCC	1EK316	For 5.7" Clear type, Transparent, With a hole for the USB environmental protection cover, A set of 5 sheets.	

GT25 Model

Product	Model	Model code	Remarks	
GT25 Model	GT2512	GT2512-STBA	1EA580	12.1" SVGA [800×600 dots] TFT color LCD 65536 colors 100 to 240VAC, User memory Memory for storage (ROM): 32MB, Memory for operation (RAM): 80MB GT Designer3 Version1 (GOT2000) 1.155M or later is required.
		GT2512-STBD	1EA581	12.1" SVGA [800×600 dots] TFT color LCD 65536 colors 24VDC, User memory Memory for storage (ROM): 32MB, Memory for operation (RAM): 80MB GT Designer3 Version1 (GOT2000) 1.155M or later is required.
	GT2510	GT2510-VTBA	1EA560	10.4" VGA [640×480 dots] TFT color LCD 65536 colors 100 to 240VAC, User memory Memory for storage (ROM): 32MB, Memory for operation (RAM): 80MB GT Designer3 Version1 (GOT2000) 1.165X or later is required.
		GT2510-VTBD	1EA561	10.4" VGA [640×480 dots] TFT color LCD 65536 colors 24VDC, User memory Memory for storage (ROM): 32MB, Memory for operation (RAM): 80MB GT Designer3 Version1 (GOT2000) 1.165X or later is required.
	GT2508	GT2508-VTBA	1EA530	8.4" VGA [640×480 dots] TFT color LCD 65536 colors 100 to 240VAC, User memory Memory for storage (ROM): 32MB, Memory for operation (RAM): 80MB GT Designer3 Version1 (GOT2000) 1.165X or later is required.
		GT2508-VTBD	1EA531	8.4" VGA [640×480 dots] TFT color LCD 65536 colors 24VDC, User memory Memory for storage (ROM): 32MB, Memory for operation (RAM): 80MB GT Designer3 Version1 (GOT2000) 1.165X or later is required.
GT25 Handy GOT	GT2506HS-VTBD	09J922	Display section: 6.5" VGA, TFT color LCD, 65536 colors, panel color: black, power supply: 24VDC GT Works3 Version1.195D or later.	

CNC SYSTEM I/O UNIT AND OTHERS

[M800/M80/E80 Series]

List of Units

Classification	Type	Remarks	Supported Series				
			M800W	M800S	M80W	M80	E80
[Operation Panel I/O Unit]							
DI 24V/0V common input	DO Source output	FCU8-DX830	DI: 64-points 24V/0V common type, DO: 64-points source type, Manual pulse generator input: 3ch, Remote I/O 2.0 I/F, RIO occupied stations (fixed): 1 to 4 and 7 to 14, 20 to 22, RIO extensible stations: 5, 6, 15 to 19, 23 to 64 (For Windows-based display unit)	○	○	○	○
		FCU8-DX730	DI: 64-points 24V/0V common type, DO: 64-points source type, Manual pulse generator input: 3ch, Remote I/O 2.0 I/F, RIO occupied stations (fixed): 1, 2 and 7 to 12, 20 to 22, RIO extensible stations: 3 to 6 and 15 to 19, 23 to 64 (For non-Windows-based display unit)	○	○	○	○
		FCU8-DX750	DI: 96-points 24V/0V common type, DO: 64-points source type, Manual pulse generator input: 3ch, Remote I/O 2.0 I/F, RIO occupied stations (fixed): 1 to 3 and 7 to 12, 20 to 22, RIO extensible stations: 4 to 6 and 13 to 19, 23 to 64	○	○	○	○
		FCU8-DX760	DI: 96-points 24V/0V common type, DO: 96-points source type, Manual pulse generator input: 3ch, Remote I/O 2.0 I/F, RIO occupied stations (fixed): 1 to 4 and 7 to 12, 20 to 22, RIO extensible stations: 5, 6 and 13 to 19, 23 to 64	○	○	○	○
DI 24V/0V common input Safety DI 24V/0V common input	DO Source output	FCU8-DX837	DI: 64-points 24V/0V common type, DO: 64-points source type, Safety DI: 8-points 0V common type, Manual pulse generator input: 3ch, Remote I/O 2.0 I/F, RIO occupied stations (fixed): 1 to 4 and 7 to 14, 20 to 22, RIO extensible stations: 5, 6 and 15 to 19, 23 to 64 (For Windows-based display unit)	○	○	○	○
		FCU8-DX761	DI: 96-points 24V/0V common type, DO: 64-points source type, AI: 1 point, AO: 1 point, Manual pulse generator input: 3ch, Remote I/O 2.0 I/F, RIO occupied stations (fixed): 1 to 5 and 7 to 12, 20 to 22, RIO extensible stations: 6 and 13 to 19, 23 to 64	○	○	○	○
DI 24V/0V common input AO analog input	DO Source output AO Analog output	FCU8-DX834	DI: 64-points 24V/0V common type, DO: 64-points source type, Scan input: 64 points, Scan output: 64 points, Manual pulse generator input: 3ch, Remote I/O 2.0 I/F, RIO occupied stations (fixed): 1 to 4, 7 to 14, 20 to 22, RIO extensible stations: 5, 6, 15 to 19, 23 to 64 (for windows-based display)	○	○	○	○
DI 24V/0V common input Scan input	DO Source output Scan output	FCU8-DX834	DI: 64-points 24V/0V common type, DO: 64-points source type, Scan input: 64 points, Scan output: 64 points, Manual pulse generator input: 3ch, Remote I/O 2.0 I/F, RIO occupied stations (fixed): 1 to 4, 7 to 14, 20 to 22, RIO extensible stations: 5, 6, 15 to 19, 23 to 64	○	○	○	○
[Remote I/O Unit]							
DI 24V/0V common input	DO Source output	FCU8-DX220	DI: 32-points 24V/0V common type, DO: 32-points source type, Number of occupied stations: 1	○	○	○	○
	DO Source output AO Analog output	FCU8-DX230	DI: 64-points 24V/0V common type, DO: 48-points source type, Number of occupied stations: 2	○	○	○	○
AI analog input	AO Analog output	FCU8-DX202	AI: 4 points, AO: 1 point, Number of occupied stations: 1	○	○	○	○
DI 0V common input	DO Source output (large capacity)	FCU8-DX213	DI: 16-points 0V common type (3mA/point), DO: 8-points source type (2A/point), Number of occupied stations: 1	○	○	○	○
		FCU8-DX213-1	DI: 16-points 0V common type (9mA/point), DO: 8-points source type (2A/point), Number of occupied stations: 1	○	○	○	○
Thermistor input (12 points)		FCU8-DX408	Thermistor input: 12 points Number of occupied stations: 3	○	○	○	○
Multi-analog input (4 points)		FCU8-DX409	Multi-analog input: 4 points * Voltage input, current input, thermocouple input and resistance temperature detector input are selected for each CH. Number of occupied stations: 4	○	○	○	○
Safety DI 0V common input	Safety DO Source output (large capacity)	FCU8-DX654	Safety DI: 8-points 0V common type (3mA/point) Safety DO: 4-points source type (2A/point) Number of occupied stations: 2	○	○	○	○
		FCU8-DX654-1	Safety DI: 8-points 0V common type (9mA/point) Safety DO: 4-points source type (2A/point) Number of occupied stations: 2	○	○	○	○
DI 24V/0V common input Safety DI 0V common input	DO Source output Safety relay output	FCU8-DX651	DI: 32-points 24V/0V common type, DO: 32-points source type, Safety DI: 8-points 0V common type, Safety relay: 4-points (non-voltage contact), Relay contact welding detection Number of occupied stations: 3	○	○	○	○
[Functional safety expansion unit]							
Functional safety expansion unit		FCU8-EX133	Smart Safety observation	○	○	○	○
[Function Expansion Unit]							
Encoder (manual pulse generator) I/F expansion unit		FCU8-EX544	Encoder input 1ch 5V manual pulse generator input 2ch	○	○	○	○
CC-Link expansion unit		FCU8-EX561	CC-Link 1ch	○	○	○	○
PROFIBUS-DP master unit		FCU8-EX563	PROFIBUS-DP 1ch	○	○	○	○
CC-Link IE Field Master/local unit		FCU8-EX564	CC-Link IE Field 2ch	○	○	○	○
EtherNet/IP scanner/adaptor unit		FCU8-EX565	EtherNet/IP 1ch (Only LAN1, LAN2 cannot be used)	○	○	○	○
FL-net expansion unit		FCU8-EX568	FL-net 1ch (Only LAN1, LAN2 cannot be used)	○	○	○	○
Option relay unit		FCU8-EX702	For function expansion unit 1slot (*1)	○	○	○	○
		FCU8-EX703	For function expansion unit 2slots (*1)	○	○	○	○
Vibration cutting expansion unit		FCU8-EX744	Vibration cutting control	○	○	○	○
[Side Memory I/F Unit]							
Side memory I/F Unit		FCU8-EP201-2	SDHC 1ch, USB2.0 1ch USB communication (between side memory I/F PCB and personal computer) Unit lid (resin molded article), metal plate, etc. Exclusive for 19-type display unit	○	○	○	○
[Manual Pulse Generator]							
5V Manual pulse generator		UFO-01-2Z9	Input 5VDC, 100pulse/rev	○	○	○	○
12V Manual pulse generator		HD60C	Input 12VDC, 25 pulse/rev	○	○	○	○
[Encoder]							
Synchronous feed encoder		OSE1024-3-15-68	Input 5VDC, 1024 pulse/rev, 6000r/min, 68-square flange	○	○	○	○
		OSE1024-3-15-68-8	Input 5VDC, 1024 pulse/rev, 8000r/min, 68-square flange	○	○	○	○
		OSE1024-3-15-160	Input 5VDC, 1024 pulse/rev, 6000r/min, 160-square flange	○	○	○	○
[Handy Terminal]							
Handy terminal		HG1T-SB12UHK1346-L5		○	○	○	○
[Thermistor Sets]							
Thermistor		PT3C-51F-M2 10P		○	○	○	○
[Genuine Memory Card]							
Exclusive SD cards for MITSUBISHI CNC 1GB		FCU8-SD001G	1GB capacity	○	○	○	○
Exclusive SD cards for MITSUBISHI CNC 4GB		FCU8-SD004G	4GB capacity	○	○	○	○
[Durable Parts]							
Battery for control unit		Q6BAT	Battery cumulative data holding time: 45,000 hours (At 0 to 45°C. The life will be shorter if the temperature is high.) Battery life: Approx. 5 years (from date of battery manufacture)	○	○	○	○
[IoT Unit]							
Remote service gateway unit		FCU8-RT601	For details of a remote service gateway unit, refer to "Remote Service IQ Care Remote4U User's Manual" (IB-1501552).	○	○	○	○

DI: Digital input signals, DO: Digital output signals, AI: Analog input signals, AO: Analog output signals

(*1) This is required when FCU8-EX56x/FCU8-EX744 is used in M800S/M80 series.

[C80 Series]

MELSEC iQ-R Series modules

Product	Model	Model code	Remarks			
PLC CPU	R04CPU	1FMA00	Program capacity, 40K steps; basic operation processing speed (LD instruction), 0.98 ns			
	R08CPU	1FMA01	Program capacity, 80K steps; basic operation processing speed (LD instruction), 0.98 ns			
	R16CPU	1FMA02	Program capacity, 160K steps; basic operation processing speed (LD instruction), 0.98 ns			
	R32CPU	1FMA03	Program capacity, 320K steps; basic operation processing speed (LD instruction), 0.98 ns			
	R120CPU	1FMA04	Program capacity, 1200K steps; basic operation processing speed (LD instruction), 0.98 ns			
SD memory card	NZ1MEM-2GBSD	1WC535	SD memory card, 2GB bytes			
Extended SRAM cassette	NZ2MC-1MBS	1FMB00	1M bytes			
Main base	R35B	1FME00	5 slots, for MELSEC iQ-R Series modules			
	R38B	1FME01	8 slots, for MELSEC iQ-R Series modules			
	R312B	1FME02	12 slots, for MELSEC iQ-R Series modules			
	R65B	1FME07	5 slots, for MELSEC iQ-R Series modules			
Extension base	R68B	1FME06	8 slots, for MELSEC iQ-R Series modules			
	R612B	1FME05	12 slots, for MELSEC iQ-R Series modules			
	RQ65B	1FME08	5 slots, for MELSEC-Q Series modules			
RQ extension base	RQ68B	1FME03	8 slots, for MELSEC-Q Series modules			
	RQ612B	1FME04	12 slots, for MELSEC-Q Series modules			
Extension cable	RC06B	1FM001	0.6 m cable for extension and RQ extension base units			
	RC12B	1FM002	1.2 m cable for extension and RQ extension base units			
	RC30B	1FM003	3 m cable for extension and RQ extension base units			
	RC50B	1FM004	5 m cable for extension and RQ extension base units			
Power supply	R61P	1FMC00	AC power supply; input, 100 to 240 V AC; output, 5 V DC/6.5 A			
	R62P	1FMC02	AC power supply; input, 100 to 240 V AC; output, 5 V DC/3.5 A, 24 V DC/0.6 A			
	R63P	1FMC01	DC power supply; input, 24 V DC; output, 5 V DC/6.5 A			
	R64P	1FMC03	AC power supply; input, 100 to 240 V AC; output, 5 V DC/9 A			
Input	AC	RX10	1FM103	AC input, 16 points; 100 to 120 V AC (50/60 Hz)		
		RX40C7	1FM100	DC input, 16 points; 24 V DC, 7.0 mA		
		RX41C4	1FM101	DC input, 32 points; 24 V DC, 4.0 mA		
		RX42C4	1FM102	DC input, 64 points; 24 V DC, 4.0 mA		
	DC(Positive Common/Negative Common Shared Type)	RX41C4-TS	1FM113	DC input, 32 points; 24VDC, 4.0mA, Spring clamp terminal block		
		RY10R2	1FM153	Relay output, 16 points; 24 V DC/2 A, 240 V AC/2 A		
		RY18R2A	1FM15A	Relay output, 8 points; 24VDC/2A, 240VAC/2A		
Output	Relay	RY20S6	1FM157	Triac output, 16 points; 100 to 240VAC/0.6A		
		RY40NT5P	1FM150	Transistor (sink) output, 16 points; 12 to 24 V DC, 0.5 A		
	Triac	RY41NT2P	1FM151	Transistor (sink) output, 32 points; 12 to 24 V DC, 0.2 A		
		RY42NT2P	1FM152	Transistor (sink) output, 64 points; 12 to 24 V DC, 0.2 A		
	Transistor (Sink)	RY40PT5P	1FM154	Transistor (source) output, 16 points; 12 to 24 V DC, 0.5 A		
		RY41PT1P	1FM155	Transistor (source) output, 32 points; 12 to 24 V DC, 0.1 A		
		RY42PT1P	1FM156	Transistor (source) output, 64 points; 12 to 24 V DC, 0.1 A		
		RY41PT1P-TS	1FM15E	Transistor (source) output, 32 points; 12 to 24VDC, 0.1A, Spring clamp terminal block		
I/O combined	DC input/transistor output	RH42C4NT2P	1FM200	DC input, 32 points; 24 V DC, 4.0 mA Transistor (sink) output, 32 points; 12 to 24 V DC, 0.2 A		
Connector		A6CON1	13L101	Soldering 32 point-connector (40-pin connector)		
		A6CON2	13L102	Solderless terminal connection 32 point-connector (40-pin connector)		
		A6CON3	13L103	Flat-cable pressure displacement 32 point-connector (40-pin connector)		
		A6CON4	13L124	Soldering 32 point-connector (40-pin connector, bidirectional cable mountable)		
Spring clamp terminal block		Q6TE-18SN	1W4299	For 16-point I/O modules, 0.3 to 1.5 mm ² (22...16 AWG)		
Connector/terminal block conversion module		A6TBX70	13L112	For positive common input modules (3-wire type)		
		A6TBXY36	13L106	For positive common input modules and sink output modules (standard type)		
		A6TBXY54	13L109	For positive common input modules and sink output modules (2-wire type)		
		AC05TB	13L006	For A6TBXY36, A6TBXY54, and A6TBX70 (positive common/sink type), 0.5 m		
Connector/terminal block conversion module	cable	AC10TB	13L007	For A6TBXY36, A6TBXY54, and A6TBX70 (positive common/sink type), 1 m		
		AC20TB	13L008	For A6TBXY36, A6TBXY54, and A6TBX70 (positive common/sink type), 2 m		
		AC30TB	13L009	For A6TBXY36, A6TBXY54, and A6TBX70 (positive common/sink type), 3 m		
		AC50TB	13L010	For A6TBXY36, A6TBXY54, and A6TBX70 (positive common/sink type), 5 m		
		AC80TB	13L026	For A6TBXY36, A6TBXY54, and A6TBX70 (positive common/sink type), 8 m *Common current 0.5 A or lower		
		AC100TB	13L027	For A6TBXY36, A6TBXY54, and A6TBX70 (positive common/sink type), 10 m *Common current 0.5 A or lower		
		Relay terminal module		A6TE2-16SRN	13L131	For 40-pin connector 24 V DC transistor output modules (sink type)
		Relay terminal module	cable	AC06TE	13L021	For A6TE2-16SRN, 0.6 m
AC10TE	13L022			For A6TE2-16SRN, 1 m		
AC30TE	13L023			For A6TE2-16SRN, 3 m		
AC50TE	13L024			For A6TE2-16SRN, 5 m		
AC100TE	13L025			For A6TE2-16SRN, 10 m		
Analog input	Voltage input	R60ADV8	1FM503	8 channels for voltage inputs -10 to 10 V DC, -32000 to 32000; 80 μs/CH		
		R60ADI8	1FM504	8 channels for current inputs 0 to 20 mA DC/0 to 32000; 80 μs/CH		
	Voltage/current input	R60AD4	1FM501	4 channels for voltage/current inputs -10 to 10 V DC, -32000 to 32000; 0 to 20 mA DC, 0 to 32000; 80 μs/CH		
Analog output	Voltage output	R60DAV8	1FM505	8 channels for voltage outputs -32000 to 32000, -10 to 10 V DC; 80 μs/CH		
		R60DAI8	1FM506	8 channels for current outputs 0 to 32000, 0 to 20 mA DC; 80 μs/CH		
	Voltage/current output	R60DA4	1FM502	4 channels for voltage/current outputs -32000 to 32000, -10 to 10 V DC; 0 to 20 mA DC; 80 μs/CH		
Temperature control	Platinum temperature-measuring resistor	R60TCRT4	1FY40E	RTD (Pt100, JPt100), 4 channels for input		
		R60TCRT4BW	1FY40F	RTD (Pt100, JPt100), 4 channels for input, heater disconnection detection		
	Thermocouple	R60TCRT2TT2	1FY40C	Thermocouple (B, R, S, K, E, J, T, N, U, L, PL@, W5Re/W26Re), 4 channels for input (2 channels can also be used for RTD input)		
		R60TCRT2TT2BW	1FY40D	Thermocouple (B, R, S, K, E, J, T, N, U, L, PL@, W5Re/W26Re), 4 channels for input (2 channels can also be used for RTD input), heater disconnection detection		

MEMO

Product	Model	Model code	Remarks	
High-speed counter	RD62P2	1FM50B	5/12/24 V DC input, 2 channels; counting speed, max. 200k pulse/s; external output, transistor (sink type)	
	RD62D2	1FM50C	Differential input, 2 channels; max. counting speed, 8M pulse/s; external output, transistor (sink type)	
	RD62P2E	1FM50D	5/12/24 V DC input, 2 channels; counting speed, max. 200k pulse/s; external output, transistor (source type)	
Ethernet	RJ71EN71	1FM601	1 Gbps/100 Mbps/10 Mbps, 2 ports Multi-network connectivity (Ethernet/CC-Link IE)	
Serial communication	RJ71C24	1FM604	Max. 230.4 kbps; RS-232, 1 channel; RS-422/485, 1 channel	
	RJ71C24-R2	1FM605	Max. 230.4 kbps; RS-232, 2 channels	
	RJ71C24-R4	1FM606	Max. 230.4 kbps; RS-422/485, 2 channels	
MES Interface	RD81MES96	1FTD00	1000BASE-T/100BASE-TX/10BASE-T Database connection (MX MESInterface-R is required)	
CC-Link IE Control	RJ71GP21-SX	1FM602	1 Gbps, fiber-optic cable, control/normal station	
CC-Link IE Field	RJ71GF11-T2	1FM600	1 Gbps, master/local station	
CC-Link	RJ61BT11	1FM603	Max. 10 Mbps, master/local station, CC-Link Ver.2 supported	
CC-Link Remote I/O module	Screw terminal block type	AJ65SBTB1-16D	1W5131	Input 16 points: 24VDC (positive/negative common shared) 1-wire type Terminal block type Response time 1.5ms
		AJ65SBTB1-32D	1W5141	Input 32 points: 24VDC (positive/negative common shared) 1-wire type Terminal block type Response time 1.5ms
		AJ65SBTB1-16TE	1W5128	Output 16 points: 12/24VDC (0.1A) Transistor output (source type) 1-wire type Terminal block type
	Waterproof connector type	AJ65SBTB1-32TE1	1W5452	Output 32 points: 12/24VDC (0.5A) Transistor output (source type) 1-wire type Terminal block type
		AJ65FBTA4-16DE	1W5108	Input 24VDC (negative common) 4-wire type Thin, waterproof type Response time 1.5ms
		AJ65FBTA2-16TE	1W5103	Output 16 points: 12/24VDC (1.0A) Transistor output (source type) 2-wire type Thin, waterproof type

MELSEC Q Series modules

Product	Model	Model code	Remarks	
Extension base	Q63B	1W4E07	3 slots, 1 power supply module required, for Q Series modules	
	Q65B	1W4E03	5 slots, 1 power supply module required, for Q Series modules	
	Q68B	1W4E04	8 slots, 1 power supply module required, for Q Series modules	
	Q612B	1W4E05	12 slots, 1 power supply module required, for Q Series modules	
	Q52B	1W4E14	2 slots, power supply module not required, for Q Series modules	
	Q55B	1W4E15	5 slots, power supply module not required, for Q Series modules	
Extension cable	QC06B	1W4006	0.45 m cable for connecting extension base unit	
	QC06B	1W4000	0.6 m cable for connecting extension base unit	
	QC12B	1W4001	1.2 m cable for connecting extension base unit	
	QC30B	1W4002	3m cable for connecting extension base unit	
	QC50B	1W4003	5m cable for connecting extension base unit	
	QC100B	1W4004	10m cable for connecting extension base unit	
Power supply	Q61P	1W4C11	Input voltage: 100 to 240 V AC, output voltage: 5 V DC, output current: 6A	
	Q63P	1W4C02	Input voltage: 24 V DC, output voltage: 5 V DC, output current: 6A	
	Q64PN	1W4C12	Input voltage: 100 to 240 V AC, output voltage: 5 V DC, output current: 8.5A	
Output (Independent)	QY68A	1W4310	8 points, 5 to 24 V DC, 2 A/point, 8 A/module, response time: 10 ms, sink/source type, 18-point terminal block, with surge suppression, all points independent	
Analog output	Q62DA-FG	1W4571	2 channels, input (resolution): 0 to 12000, -12000 to 12000, -16000 to 16000, output: -12 to 12 V DC, 0 to 22 mA DC, conversion speed: 10 ms/2 channels, 18-point terminal block, channel isolated	
MELSECNET/H	Optical loop (SI)	QJ71LP21-25	1W4516	SI/QSI/H-PCF/broadband H-PCF fiber optic cable, dual loop, control network (control/normal station) or remote I/O network (remote master station)
	Coaxial bus	QJ71BR11	1W4511	3C-2V/5C-2V coaxial cable, single bus, control network (control/normal station) or remote I/O network (remote master station)
FL-net(OPCN-2)	Ver.2.00	QJ71FL71-T-F01	1W4593	10BASE-T, 100BASE-TX
AS-I		QJ71AS92	1W4524	Master station, AS-Interface Specification Version 2.11 compatible
DeviceNet		QJ71DN91	1W4518	Master station/local station combined use, for QCPU, DeviceNet(Release2.0) compatible.

Peripheral unit

Product	Model	Remarks	
Dual signal module	Dual-signal modules	R173SXY	I/O redundant monitoring module (Up to three modules)
	Terminal block	FA-TBS40P	Terminal block conversion (separately prepared: Mitsubishi Electric Engineering) UL supported
	Terminal block	FA-LTB40P	Terminal block conversion (separately prepared: Mitsubishi Electric Engineering)
	Cable	FA-CBL□□FMV-M	Terminal block conversion connection cable (length □□= 05: 0.5m, 10: 1m, 20: 2m, 30: 3m, 50: 5m) (separately prepared: Mitsubishi Electric Engineering)
Signal splitter		FCU7-HN387	Option (Necessary when manual pulse generator is used for two or three axes)
FL-net (OPCN-2) Interface module		ER-1FL2-T	10BASE-T, 100BASE-TX

Parts

Product	Model	Remarks
Manual pulse generator	UFO-01-2Z9	5V specification
	HD60C	12V specification, for the operation board signal splitter connection, 12V power supply separately necessary
Encoder	OSE 1024-3-15-68	6000 r/min, no straight type connector enclosed, new JIS key, 68 square flange
	OSE 1024-3-15-68-8	8000 r/min, no straight type connector enclosed, 68 square flange
	OSE 1024-3-15-160	6000 r/min, no straight type connector enclosed, new JIS key, 160 square flange
Grounding plate	Grounding plate D	With cable clamp A(2)
	Grounding plate E	With cable clamp B(1)

CNC SYSTEM GENERAL CONNECTION DIAGRAM

M800W Series Windows-based display unit (19-type)

* For connecting a remote service gateway unit, refer to the "M800W/M80W Series (Connection example of a remote service gateway unit)" described later.

⋮ Dotted lines indicate the sections prepared by the machine tool builder.
 <> Angle brackets indicates attached cable of unit.

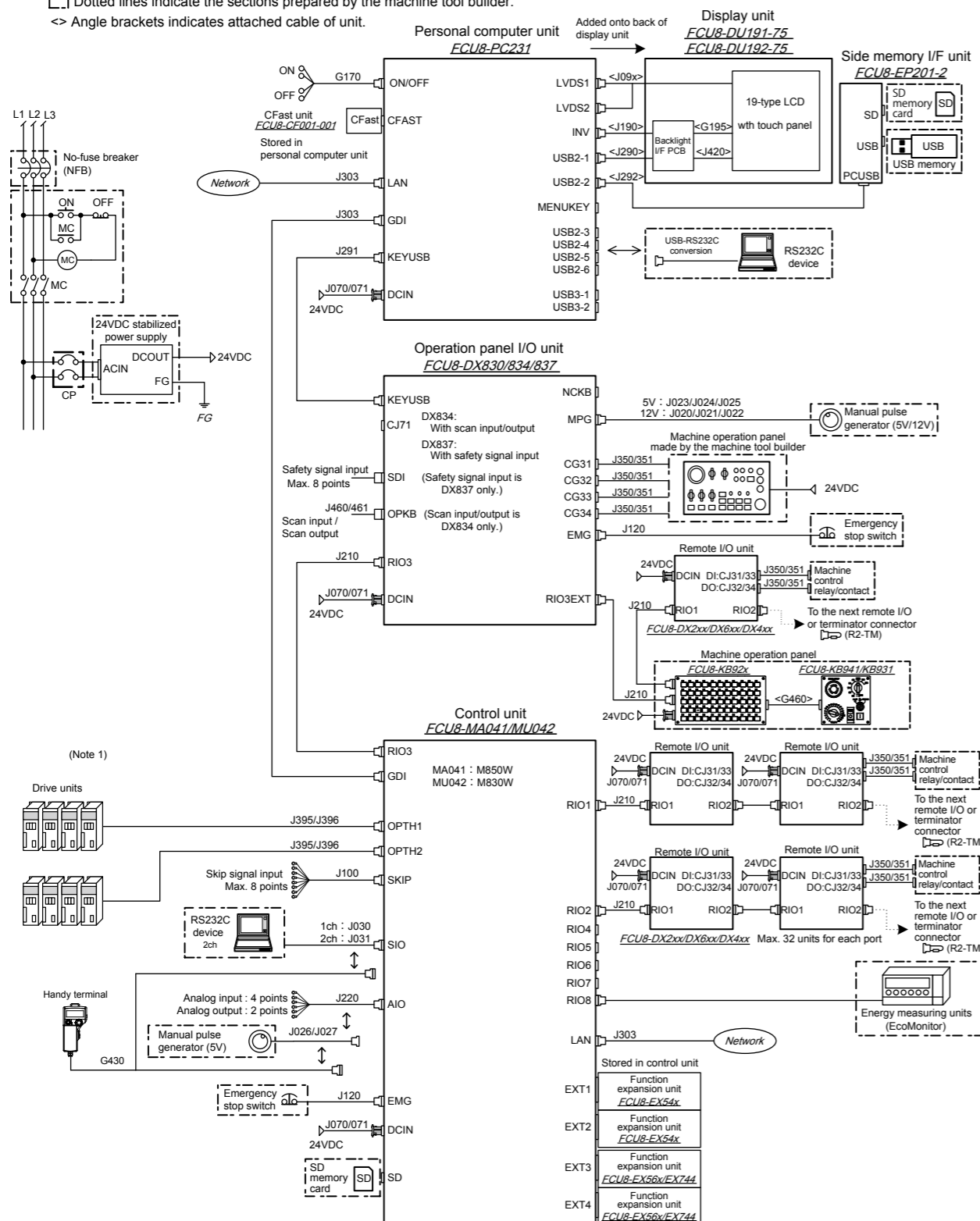

(Note 1) For connections of the drive units, refer to "DRIVE SYSTEM SYSTEM CONFIGURATION DRAWING" described later.
 (Note 2) For details of the cable and the connector, refer to "CNC SYSTEM CABLES LIST" described later.
 (Note 3) Q6BAT can be connected to the control unit for backup use.

M800W Series Windows-based display unit (15-type)

* For connecting a remote service gateway unit, refer to the "M800W/M80W Series (Connection example of a remote service gateway unit)" described later.

⋮ Dotted lines indicate the sections prepared by the machine tool builder.
 <> Angle brackets indicates attached cable of unit.

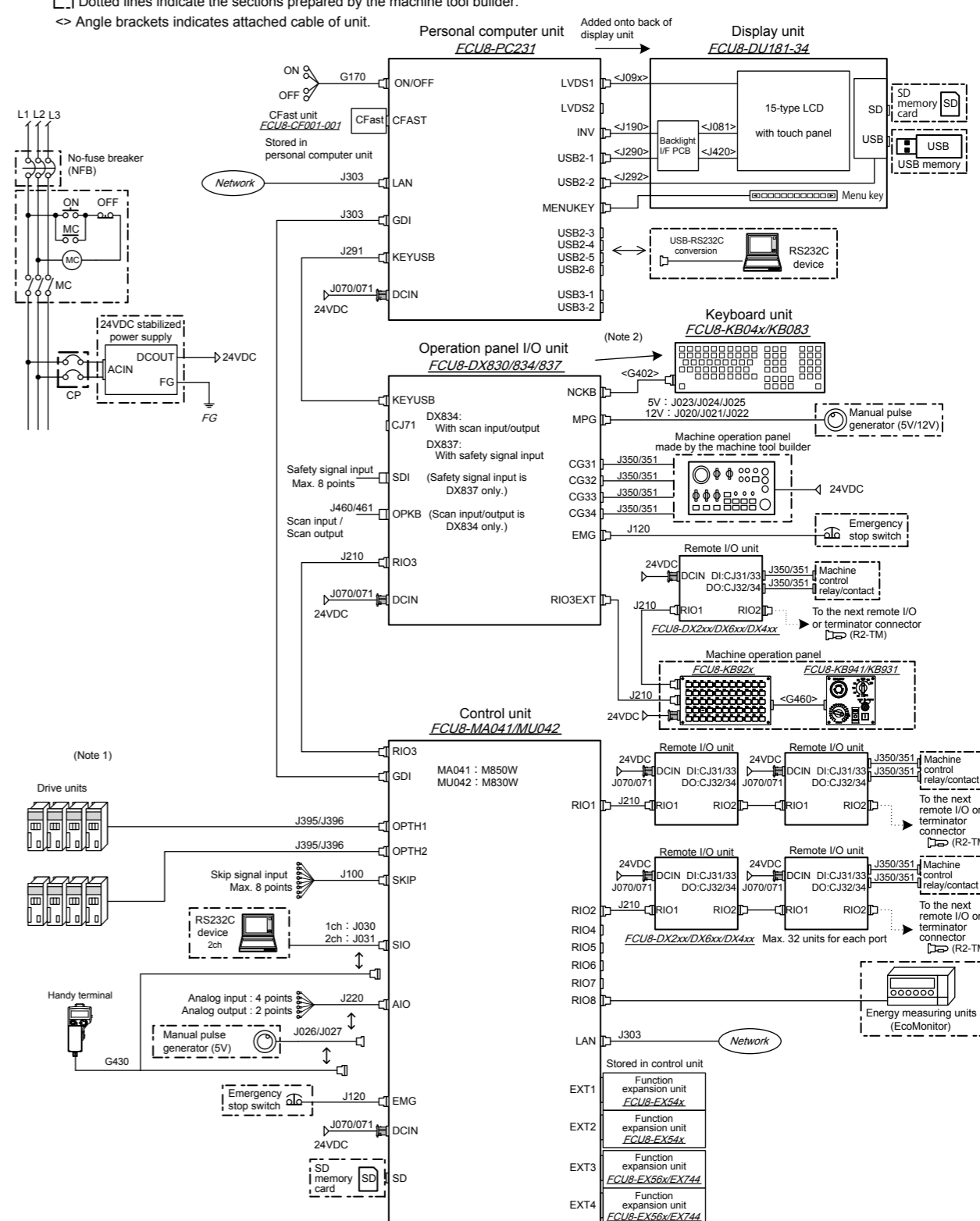

(Note 1) For connections of the drive units, refer to "DRIVE SYSTEM SYSTEM CONFIGURATION DRAWING" described later.
 (Note 2) When using a keyboard unit, install the operation panel I/O unit on the back of the keyboard unit.
 (Note 3) For details of the cable and the connector, refer to "CNC SYSTEM CABLES LIST" described later.
 (Note 4) Q6BAT can be connected to the control unit for backup use.

M800W Series non-Windows-based display unit (10.4-type/15-type)

M800S Series

(Operation panel I/O unit: FCU8-DX731/DX750/DX760/DX761)

* For connecting a remote service gateway unit, refer to the "M800W/M80W Series (Connection example of a remote service gateway unit)" described later.

* For connecting a remote service gateway unit, refer to the "M800S/M80/E80 Series (Connection example of a remote service gateway unit)" described later.

* For an operation panel I/O unit with model number FCU8-DX834, refer to the "M800S/M80/E80 Series (Connection example of an operation panel I/O unit with model number FCU8-DX834)" described later.

⋮ Dotted lines indicate the sections prepared by the machine tool builder.
 <> Angle brackets indicates attached cable of unit.

⋮ Dotted lines indicate the sections prepared by the machine tool builder.
 <> Angle brackets indicates attached cable of unit.

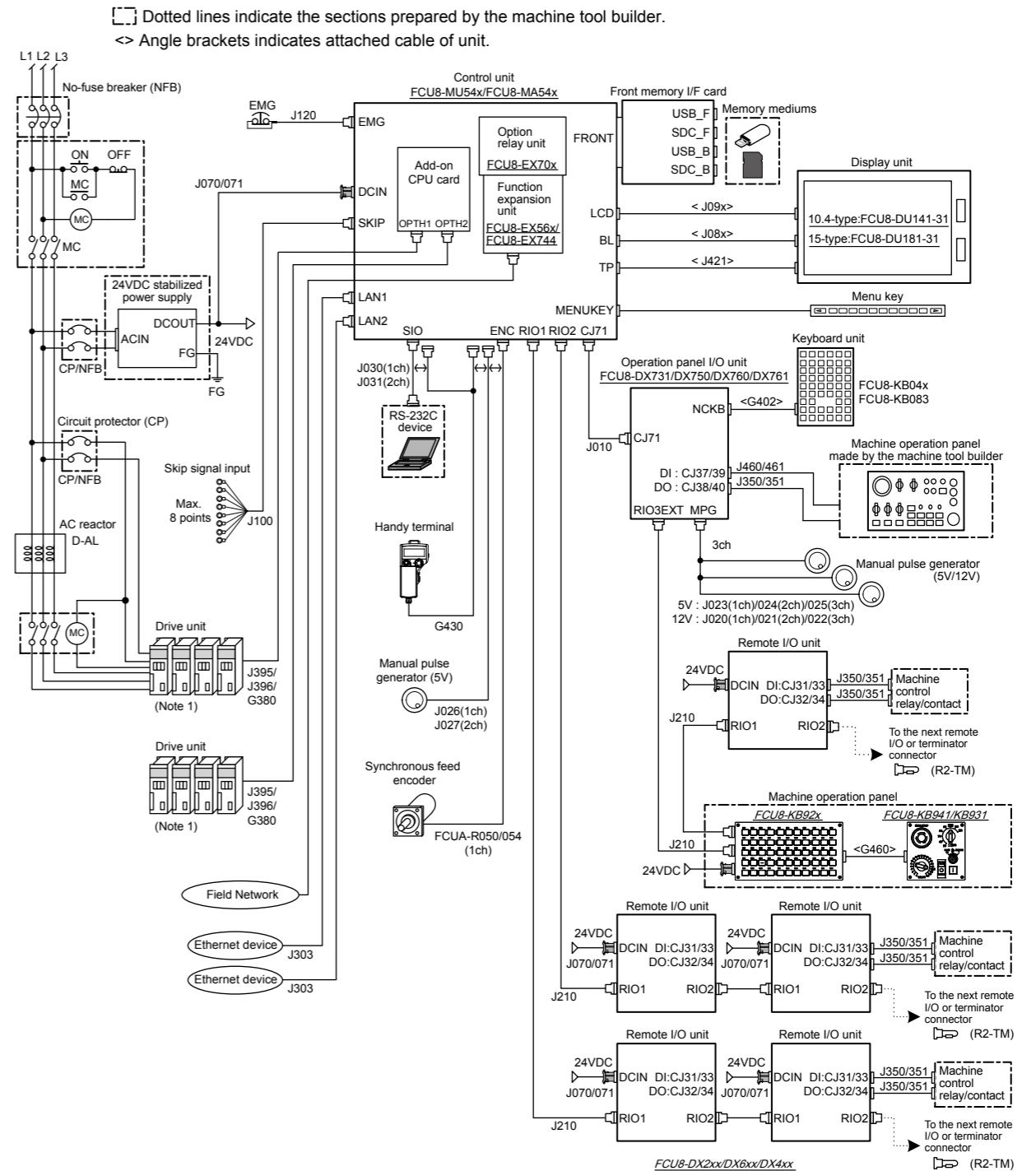
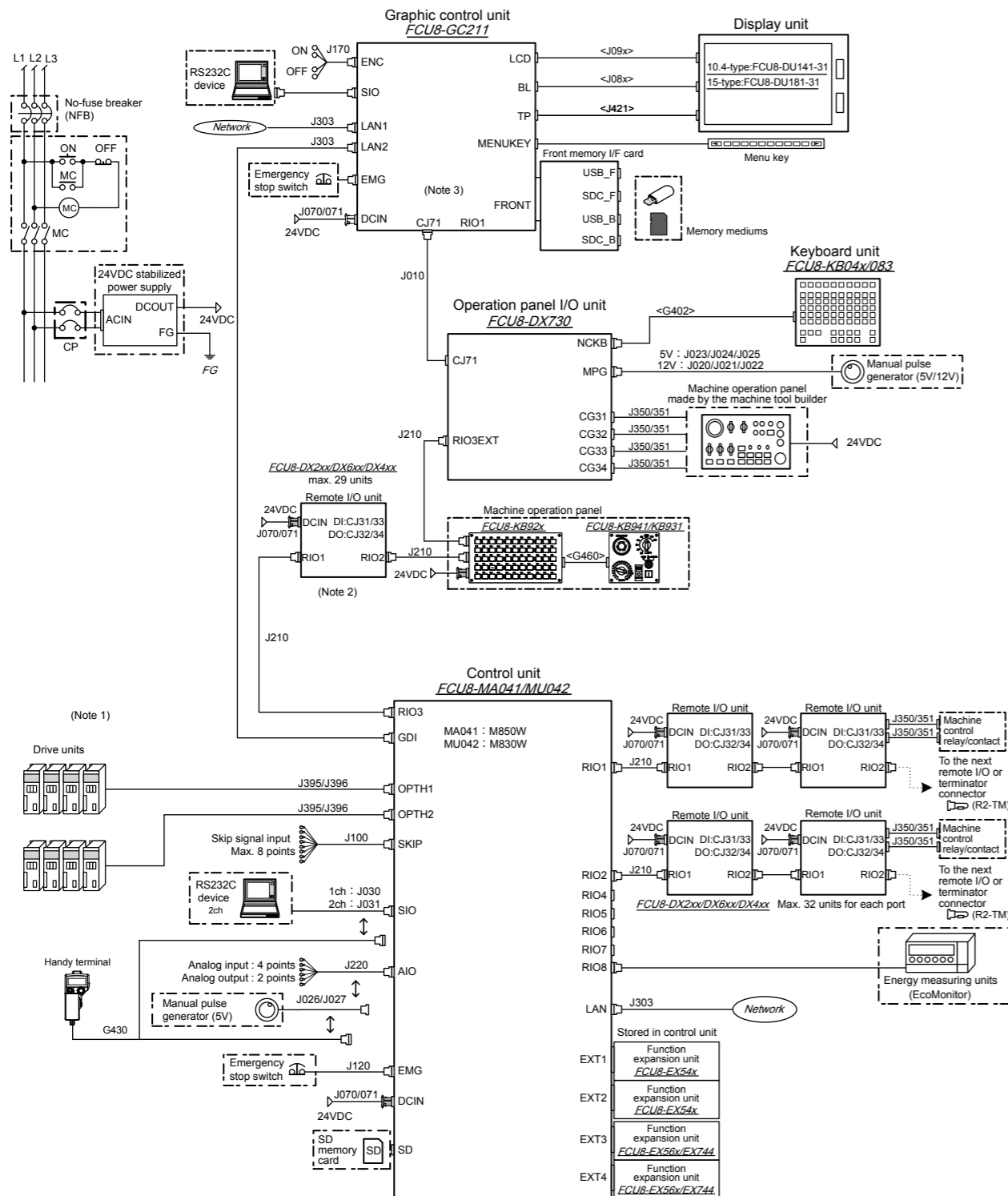

(Note 1) For connections of the drive units, refer to "DRIVE SYSTEM CONFIGURATION DRAWING" described later.
 (Note 2) When connecting a remote I/O unit to the 3rd RIO channel, insert it between the control unit and operation panel I/O unit.
 (Note 3) There is no need to connect a terminator R2-TM to the graphic control unit.
 (Note 4) For details of the cable and the connector, refer to "CNC SYSTEM CABLES LIST" described later.
 (Note 5) Q6BAT can be connected to the control unit or the graphic control unit for backup use.

(Note 1) For connections of the drive units, refer to "DRIVE SYSTEM CONFIGURATION DRAWING" described later.
 (Note 2) For details of the cable and the connector, refer to "CNC SYSTEM CABLES LIST" described later.
 (Note 3) Q6BAT can be connected to the control unit for backup use.

■M80W Series Windows-based display unit (19-type)

■M80W Series Windows-based display unit (15-type)

* For connecting a remote service gateway unit, refer to the "M800W/M80W Series (Connection example of a remote service gateway unit)" described later.

* For connecting a remote service gateway unit, refer to the "M800W/M80W Series (Connection example of a remote service gateway unit)" described later.

⋮ Dotted lines indicate the sections prepared by the machine tool builder.
 <> Angle brackets indicates attached cable of unit.

⋮ Dotted lines indicate the sections prepared by the machine tool builder.
 <> Angle brackets indicates attached cable of unit.

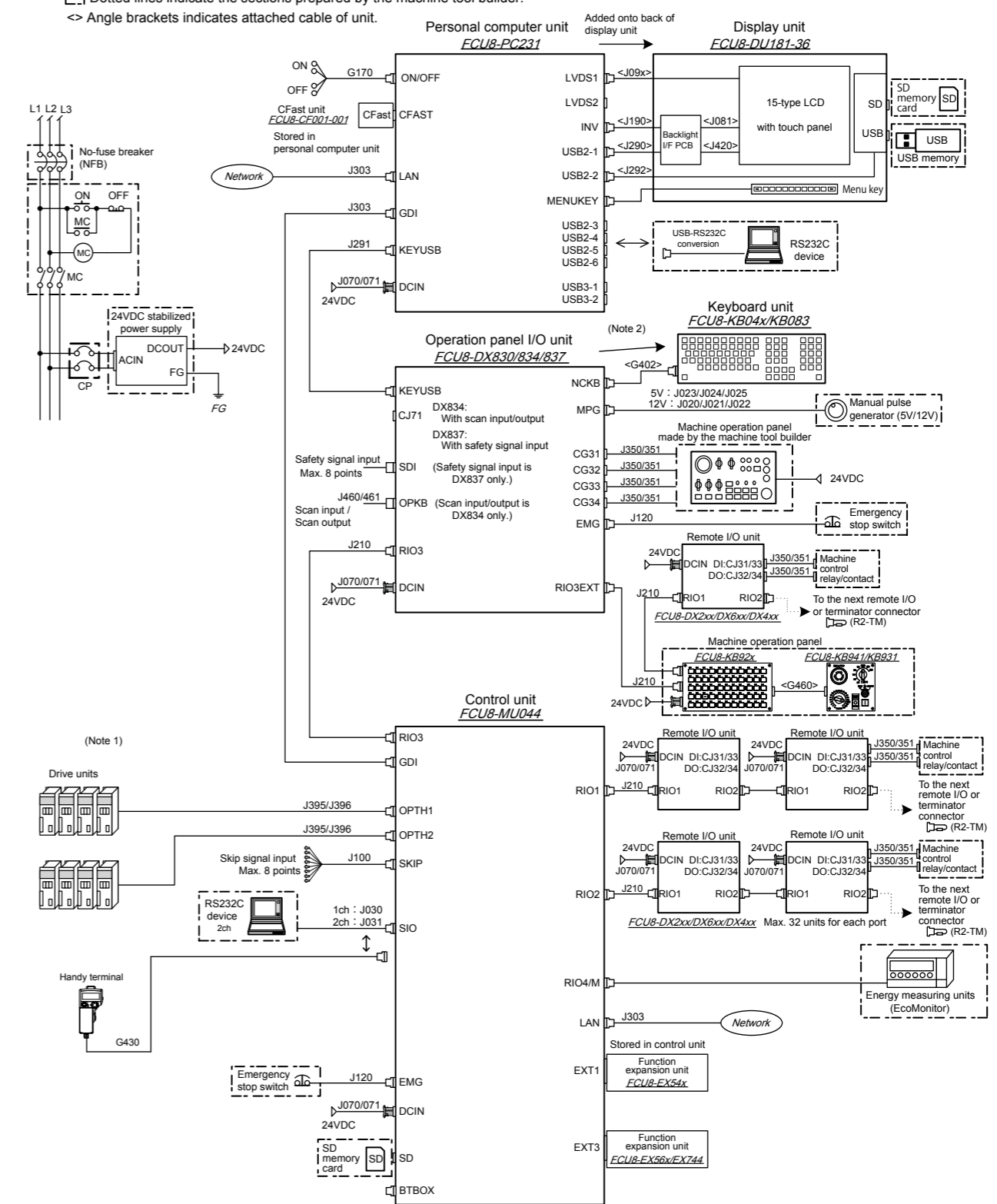
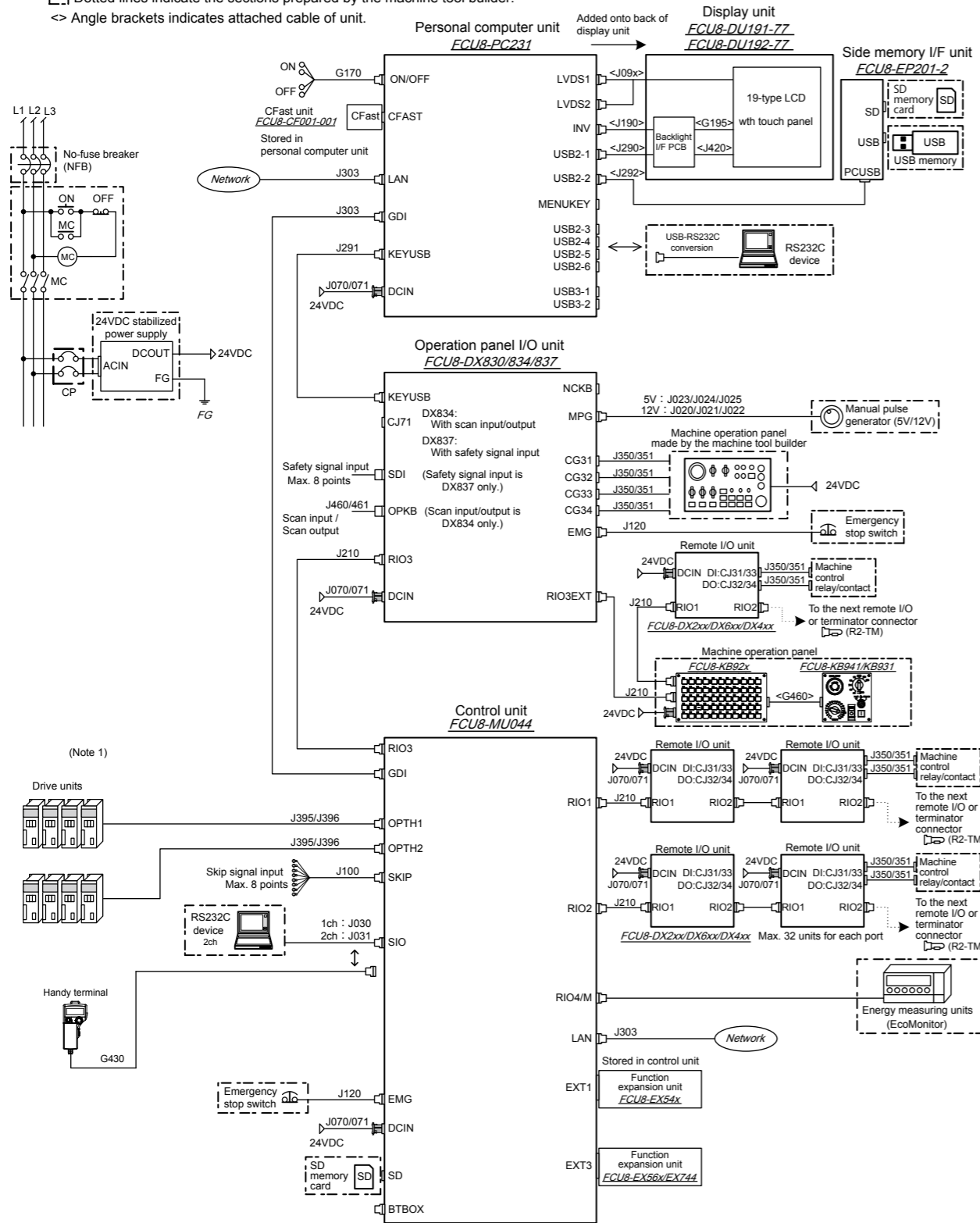

(Note 1) For connections of the drive units, refer to "DRIVE SYSTEM SYSTEM CONFIGURATION DRAWING" described later.
 (Note 2) For details of the cable and the connector, refer to "CNC SYSTEM CABLES LIST" described later.
 (Note 3) Q6BAT can be connected to the control unit for backup use.

(Note 1) For connections of the drive units, refer to "DRIVE SYSTEM SYSTEM CONFIGURATION DRAWING" described later.
 (Note 2) When using a keyboard unit, install the operation panel I/O unit on the back of the keyboard unit.
 (Note 3) For details of the cable and the connector, refer to "CNC SYSTEM CABLES LIST" described later.
 (Note 4) Q6BAT can be connected to the control unit for backup use.

M80W Series non-Windows-based display unit (8.4-type/10.4-type/15-type)

* For connecting a remote service gateway unit, refer to the "M800W/M80W Series (Connection example of a remote service gateway unit)" described later.

⋮ Dotted lines indicate the sections prepared by the machine tool builder.
 <> Angle brackets indicates attached cable of unit.

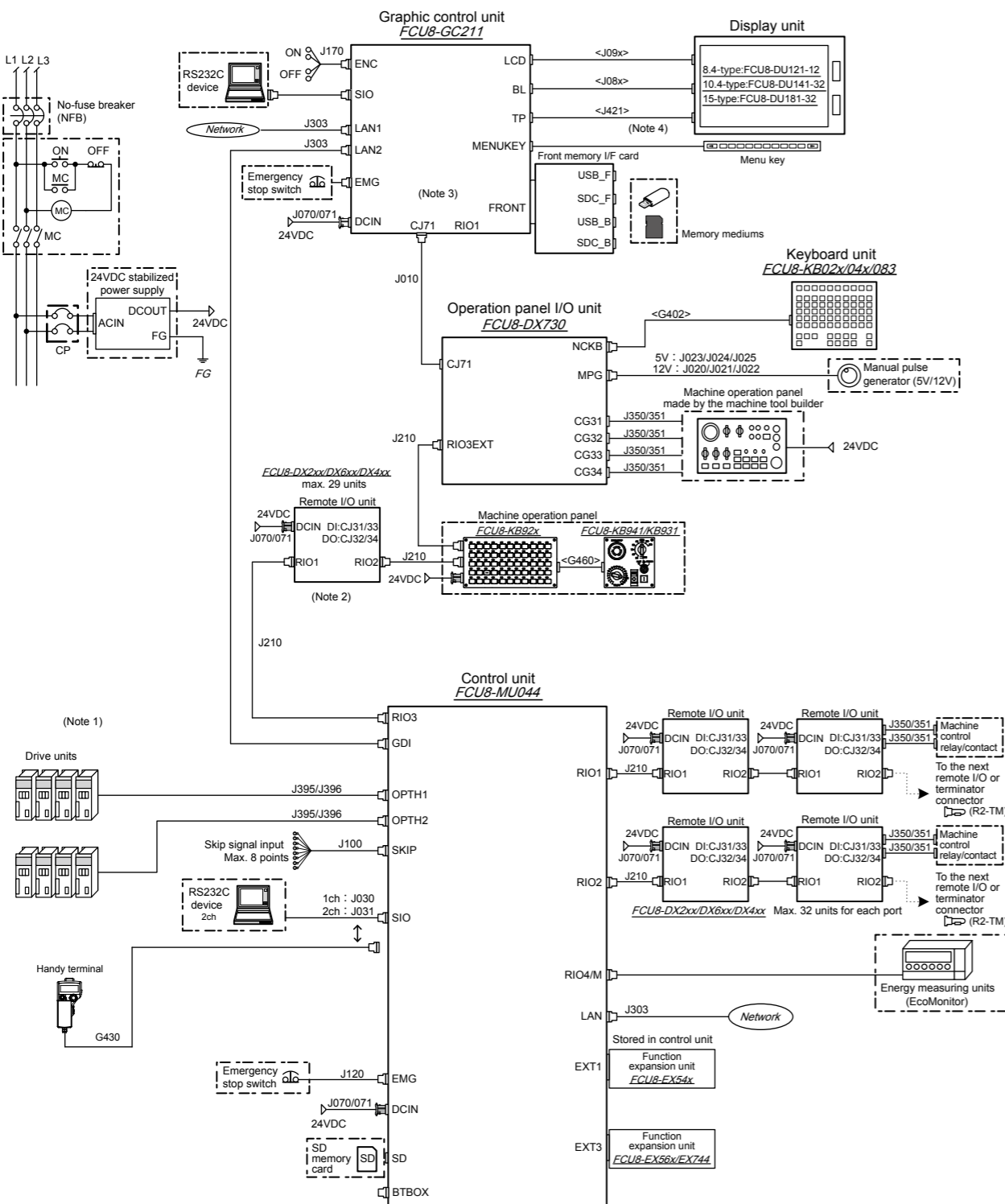

(Note 1) For connections of the drive units, refer to "DRIVE SYSTEM SYSTEM CONFIGURATION DRAWING" described later.
 (Note 2) When connecting a remote I/O unit to the 3rd RIO channel, insert it between the control unit and operation panel I/O unit.
 (Note 3) There is no need to connect a terminator R2-TM to the graphic control unit.
 (Note 4) The 8.4-type display unit is incompatible with the touchscreen. TP connector is not used.
 (Note 5) For details of the cable and the connector, refer to "CNC SYSTEM CABLES LIST" described later.
 (Note 6) Q6BAT can be connected to the control unit or the graphic control unit for backup use.

M80 Series without smart safety observation

(Operation panel I/O unit: FCU8-DX731/DX750/DX760/DX761)

* For connecting a remote service gateway unit, refer to the "M800S/M80/E80 Series (Connection example of a remote service gateway unit)" described later.

* For an operation panel I/O unit with model number FCU8-DX834, refer to the "M800S/M80/E80 Series (Connection example of an operation panel I/O unit with model number FCU8-DX834)" described later.

⋮ Dotted lines indicate the sections prepared by the machine tool builder.
 <> Angle brackets indicates attached cable of unit.

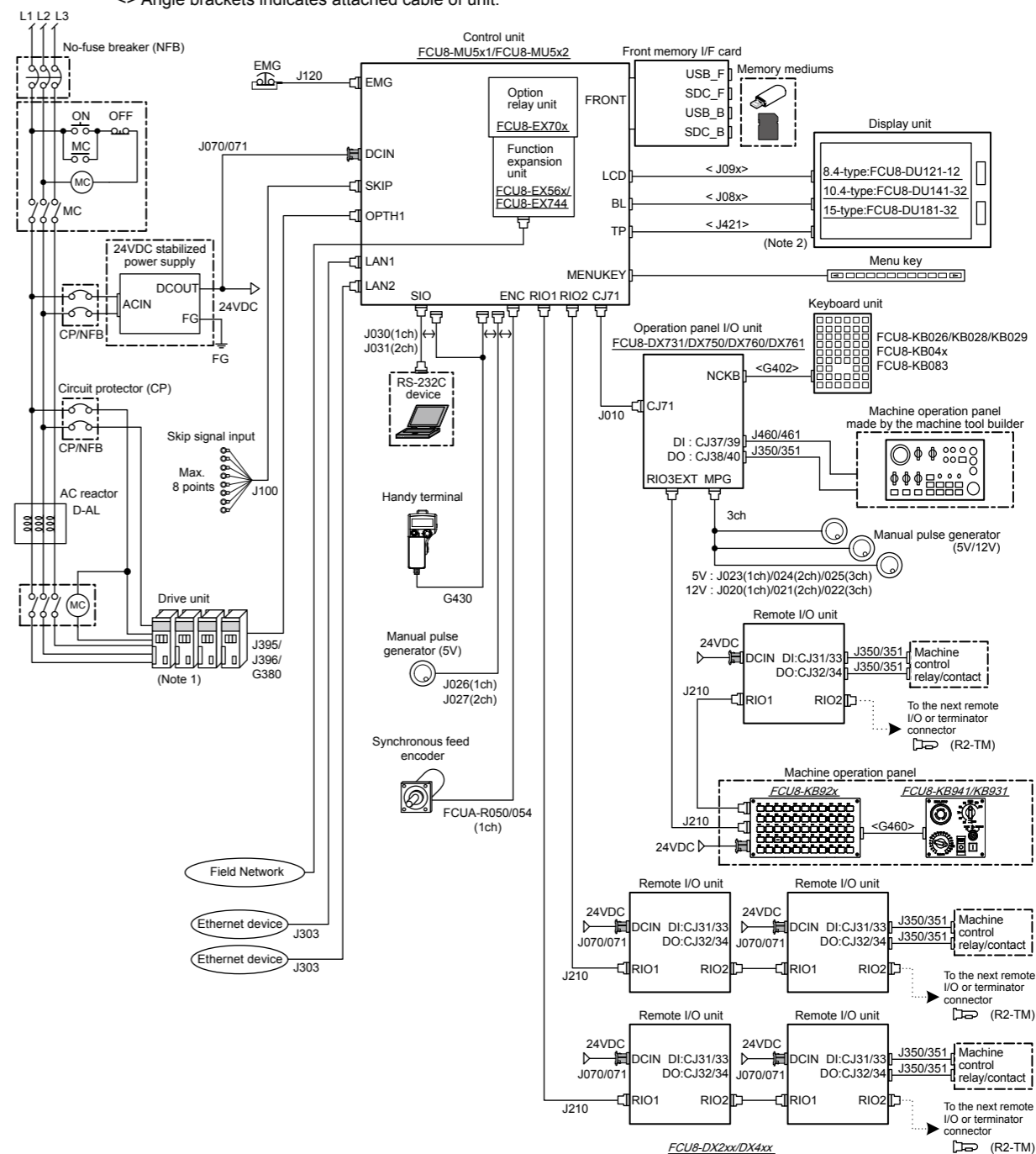

(Note 1) For connections of the drive units, refer to "DRIVE SYSTEM SYSTEM CONFIGURATION DRAWING" described later.
 (Note 2) The 8.4-type display unit is incompatible with the touchscreen. TP connector is not used.
 (Note 3) For details of the cable and the connector, refer to "CNC SYSTEM CABLES LIST" described later.
 (Note 4) Q6BAT can be connected to the control unit for backup use.

M80 Series with smart safety observation

(Operation panel I/O unit: FCU8-DX731/DX750/DX760/DX761)

- * For connecting a remote service gateway unit, refer to the "M800S/M80/E80 Series (Connection example of a remote service gateway unit)" described later.
- * For an operation panel I/O unit with model number FCU8-DX834, refer to the "M800S/M80/E80 Series (Connection example of an operation panel I/O unit with model number FCU8-DX834)" described later.

□ Dotted lines indicate the sections prepared by the machine tool builder.
 <> Angle brackets indicates attached cable of unit.

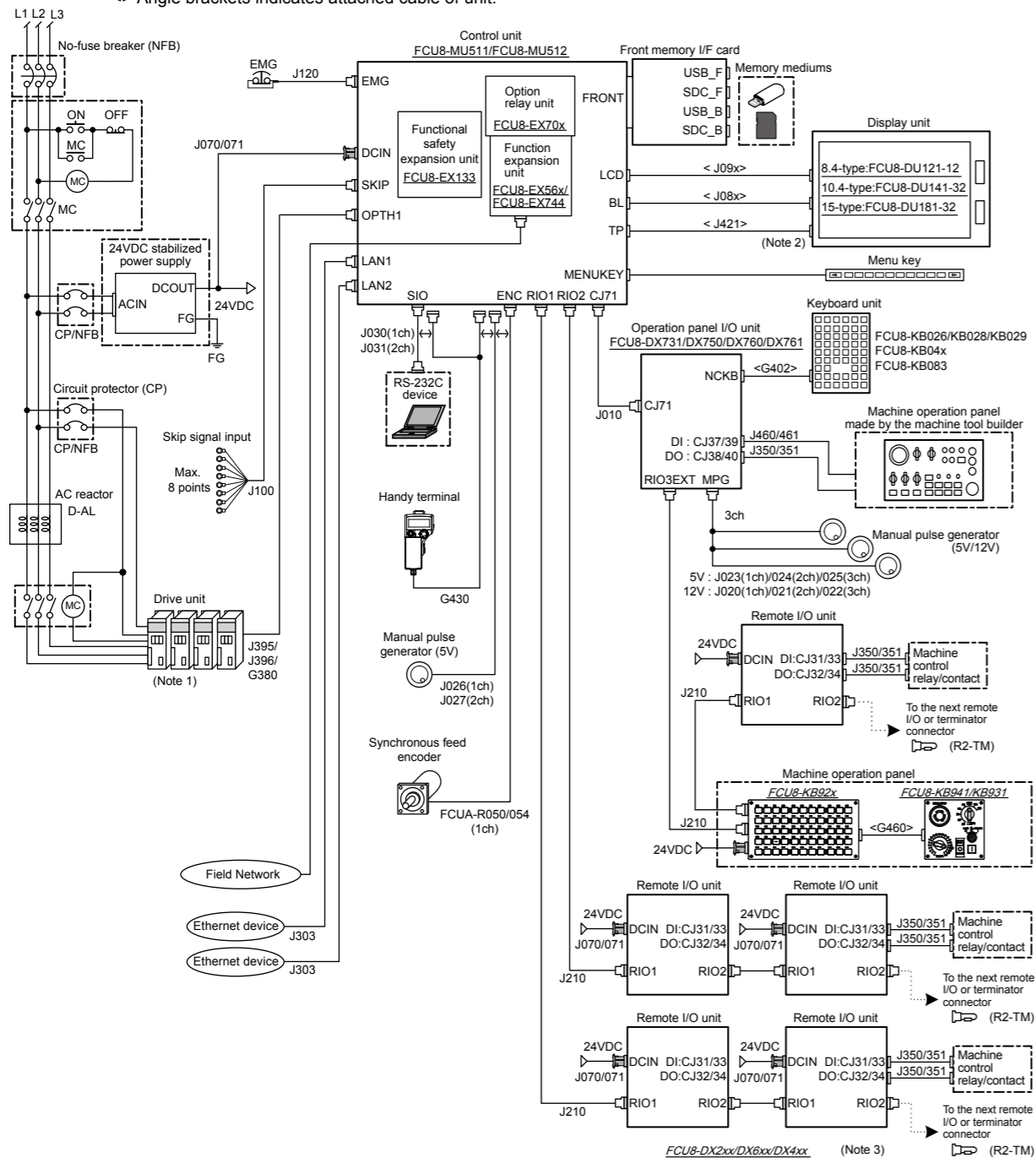

(Note 1) For connections of the drive units, refer to "DRIVE SYSTEM SYSTEM CONFIGURATION DRAWING" described later.
 (Note 2) The 8.4-type display unit is incompatible with the touchscreen. TP connector is not used.
 (Note 3) The safety remote I/O unit is available only when the functional safety expansion unit is mounted.
 (Note 4) For details of the cable and the connector, refer to "CNC SYSTEM CABLES LIST" described later.
 (Note 5) Q8BAT can be connected to the control unit for backup use.

M80 Series connecting a pulse-controlled inverter

(Operation panel I/O unit: FCU8-DX731/DX750/DX760/DX761, without smart safety observation)

- * Pulse-controlled inverter refers to an inverter capable of controlling spindle operation through pulse train input.
- * For connecting a remote service gateway unit, refer to the "M800S/M80/E80 Series (Connection example of a remote service gateway unit)" described later.
- * For an operation panel I/O unit with model number FCU8-DX834, refer to the "M800S/M80/E80 Series (Connection example of an operation panel I/O unit with model number FCU8-DX834)" described later.

□ Dotted lines indicate the sections prepared by the machine tool builder.
 <> Angle brackets indicates attached cable of unit.

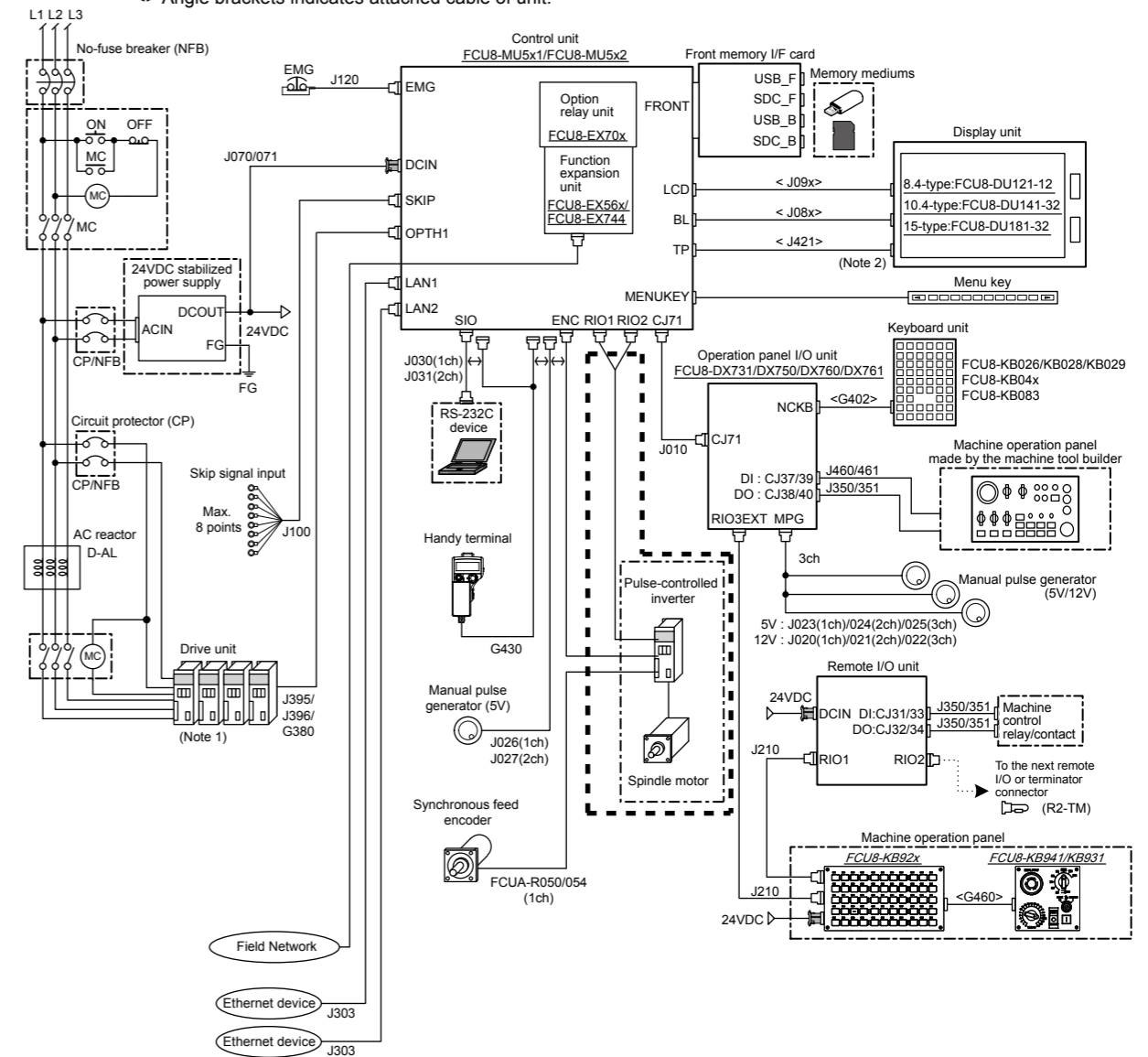

(Note 1) For connections of the drive units, refer to "DRIVE SYSTEM SYSTEM CONFIGURATION DRAWING" described later.
 (Note 2) The 8.4-type display unit is incompatible with the touchscreen. TP connector is not used.
 (Note 3) When the pulse-controlled inverter is connected, the remote I/O unit cannot be connected to the either of the RIO1 connector or the RIO2 connector.
 (Note 4) For details of the cable and the connector, refer to "CNC SYSTEM CABLES LIST" described later.
 (Note 5) Q8BAT can be connected to the control unit for backup use.

E80 Series connecting a spindle drive unit

(Operation panel I/O unit: FCU8-DX731/DX750/DX760/DX761)

- * For connecting a remote service gateway unit, refer to the "M800S/M80/E80 Series (Connection example of a remote service gateway unit)" described later.
- * For an operation panel I/O unit with model number FCU8-DX834, refer to the "M800S/M80/E80 Series (Connection example of an operation panel I/O unit with model number FCU8-DX834)" described later.

⋯ Dotted lines indicate the sections prepared by the machine tool builder.
 <> Angle brackets indicates attached cable of unit.

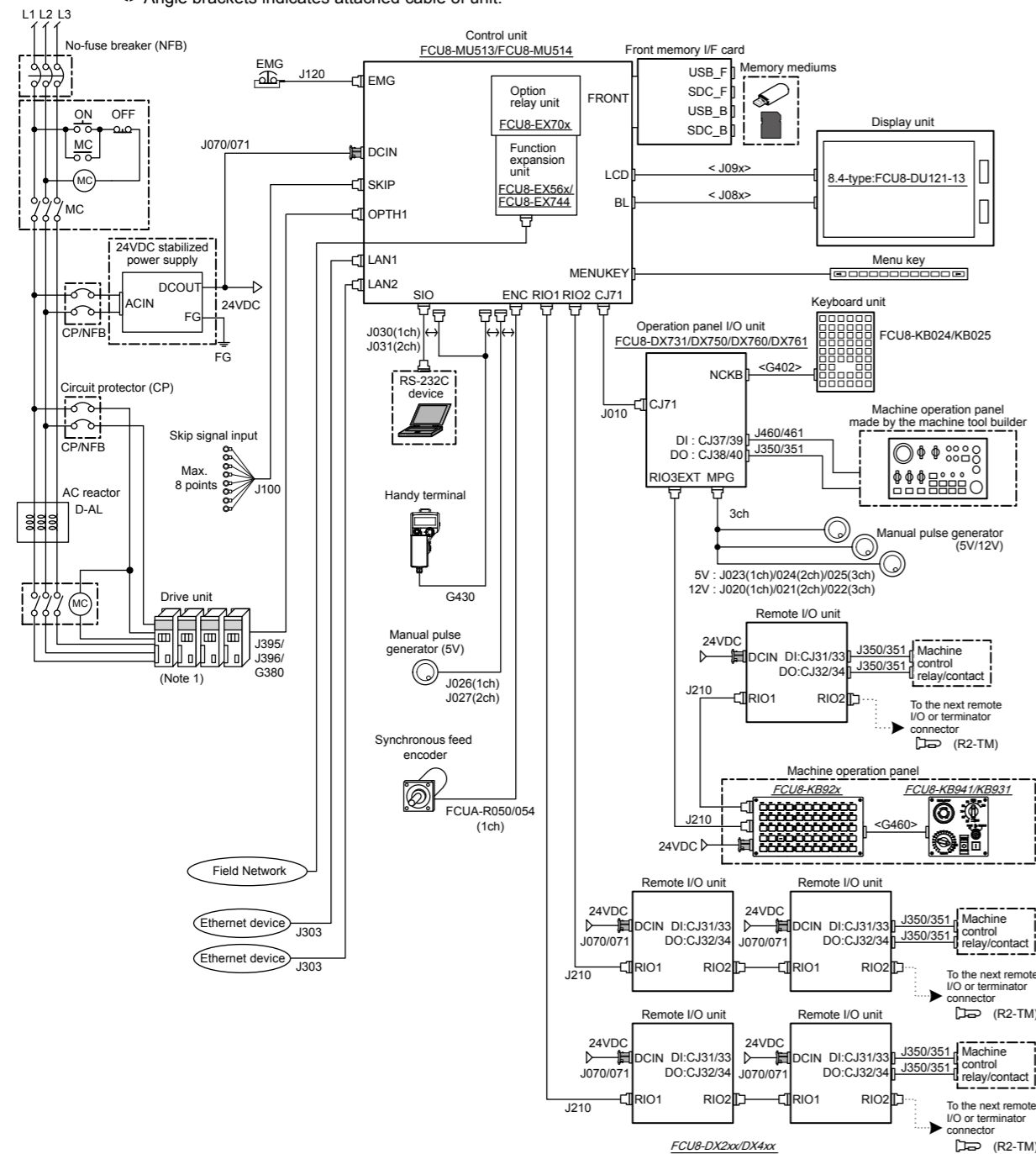

E80 Series connecting a pulse-controlled inverter

(Operation panel I/O unit: FCU8-DX731/DX750/DX760/DX761)

- * Pulse-controlled inverter refers to an inverter capable of controlling spindle operation through pulse train input.
- * For connecting a remote service gateway unit, refer to the "M800S/M80/E80 Series (Connection example of a remote service gateway unit)" described later.
- * For an operation panel I/O unit with model number FCU8-DX834, refer to the "M800S/M80/E80 Series (Connection example of an operation panel I/O unit with model number FCU8-DX834)" described later.

⋯ Dotted lines indicate the sections prepared by the machine tool builder.
 <> Angle brackets indicates attached cable of unit.

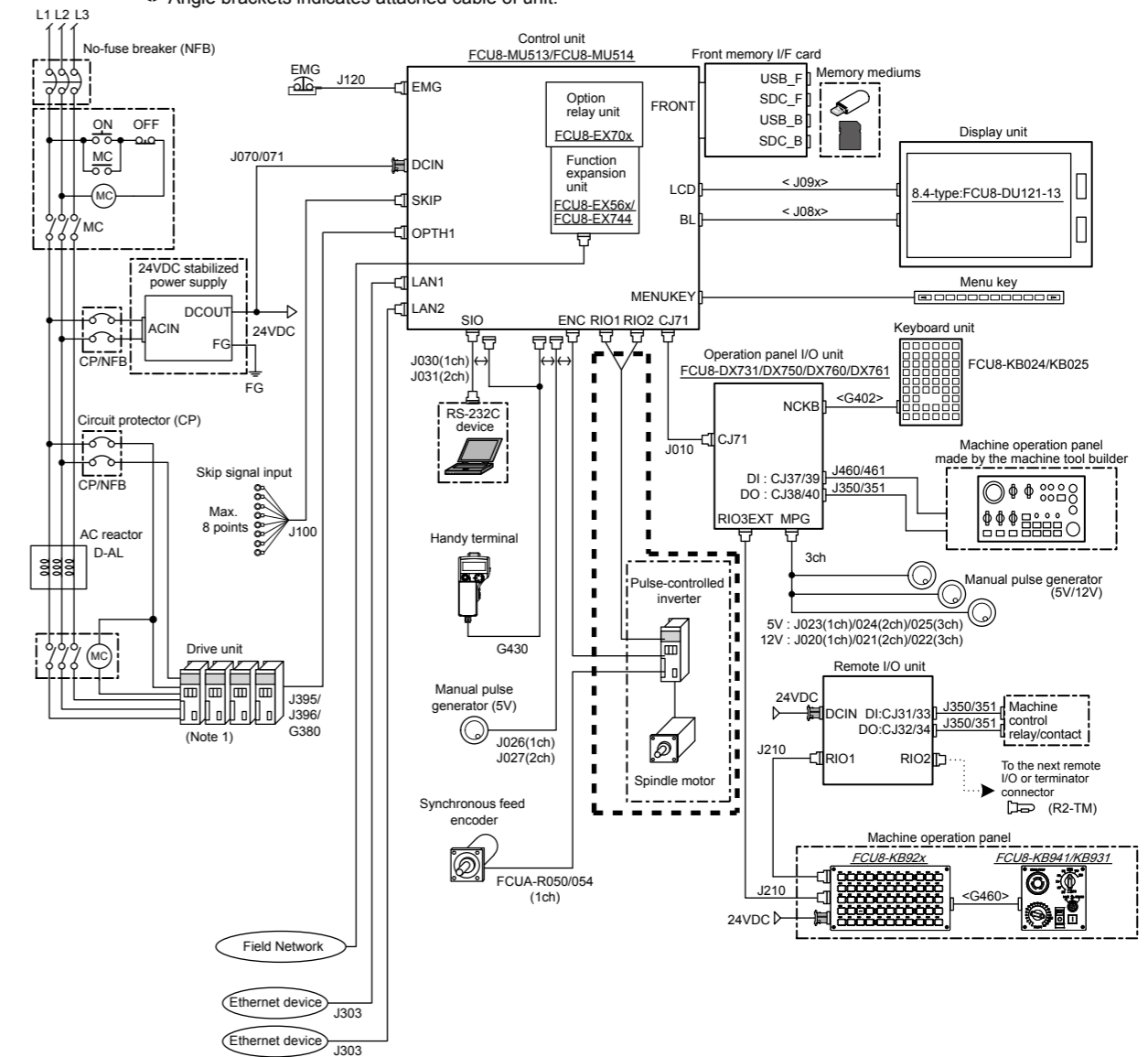

(Note 1) For connections of the drive units, refer to "DRIVE SYSTEM SYSTEM CONFIGURATION DRAWING" described later.
 (Note 2) For details of the cable and the connector, refer to "CNC SYSTEM CABLES LIST" described later.
 (Note 3) Q6BAT can be connected to the control unit for backup use.

(Note 1) For connections of the drive units, refer to "DRIVE SYSTEM SYSTEM CONFIGURATION DRAWING" described later.
 (Note 2) When the pulse-controlled inverter is connected, the remote I/O unit cannot be connected to the either of the RIO1 connector or the RIO2 connector.
 (Note 3) For details of the cable and the connector, refer to "CNC SYSTEM CABLES LIST" described later.
 (Note 4) Q6BAT can be connected to the control unit for backup use.

■M800W/M80W Series

(Connection example of remote service gateway unit)

This is an example of M800W Series, Windows-based display (19-type).

□ Dotted lines indicate the sections prepared by the machine tool builder.
 <> Angle brackets indicates attached cable of unit.

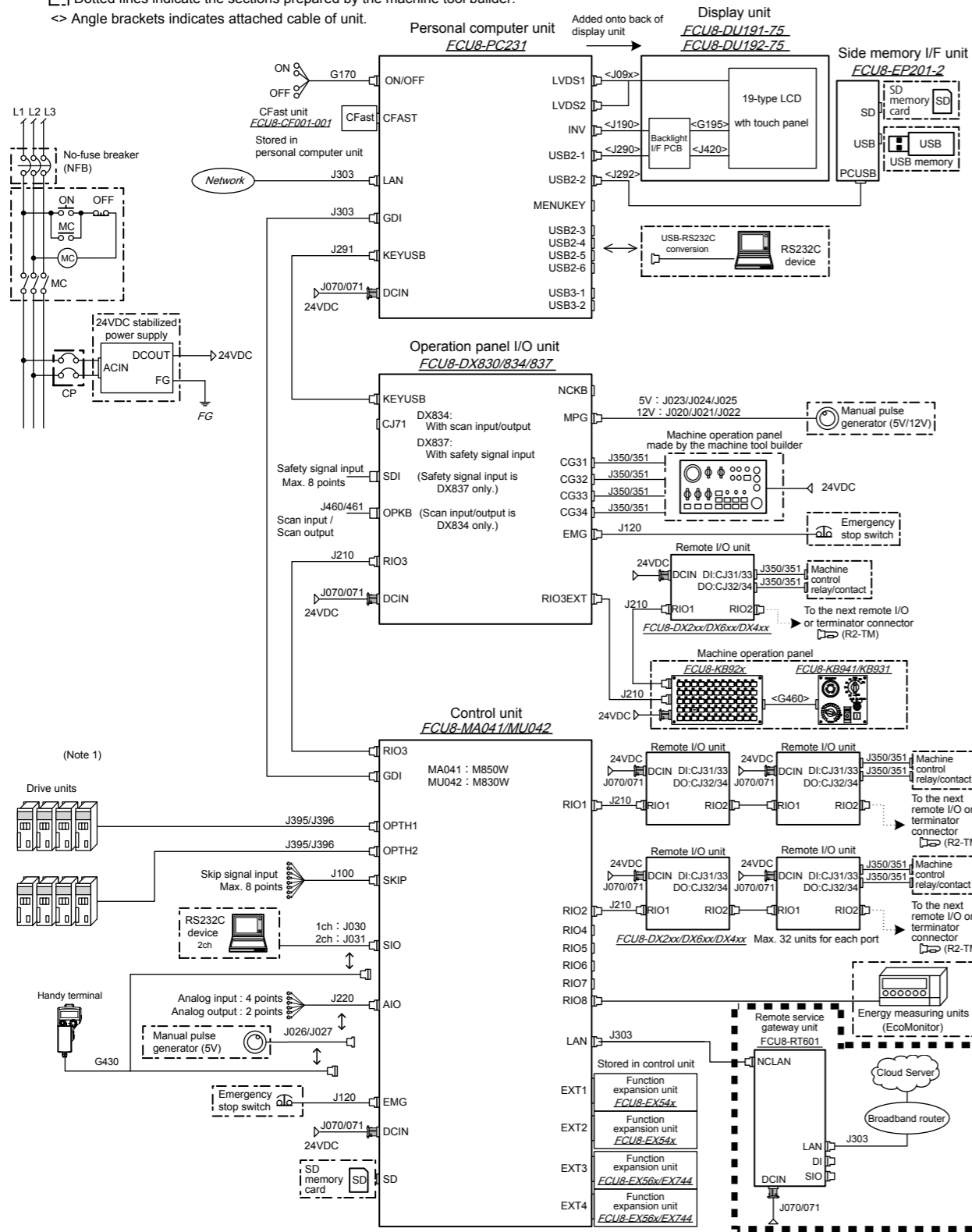

(Note 1) For connections of the drive units, refer to "DRIVE SYSTEM SYSTEM CONFIGURATION DRAWING" described later.
 (Note 2) For details of the cable and the connector, refer to "CNC SYSTEM CABLES LIST" described later.
 (Note 3) For details of a remote service gateway unit, refer to "Remote Service iQ Care Remote4U User's Manual" (IB-1501552).
 (Note 4) Q6BAT can be connected to the control unit for backup use.

■M800S/M80/E80 Series

(Connection example of a remote service gateway unit)

This is an example of M800S Series, equipped with the operation panel I/O unit FCUB-DX731/DX750/DX760/DX761.

* For an operation panel I/O unit with model number FCUB-DX834, refer to the "■M800S/M80/E80 Series (Connection example of an operation panel I/O unit with model number FCUB-DX834)" described later.

□ Dotted lines indicate the sections prepared by the machine tool builder.
 <> Angle brackets indicates attached cable of unit.

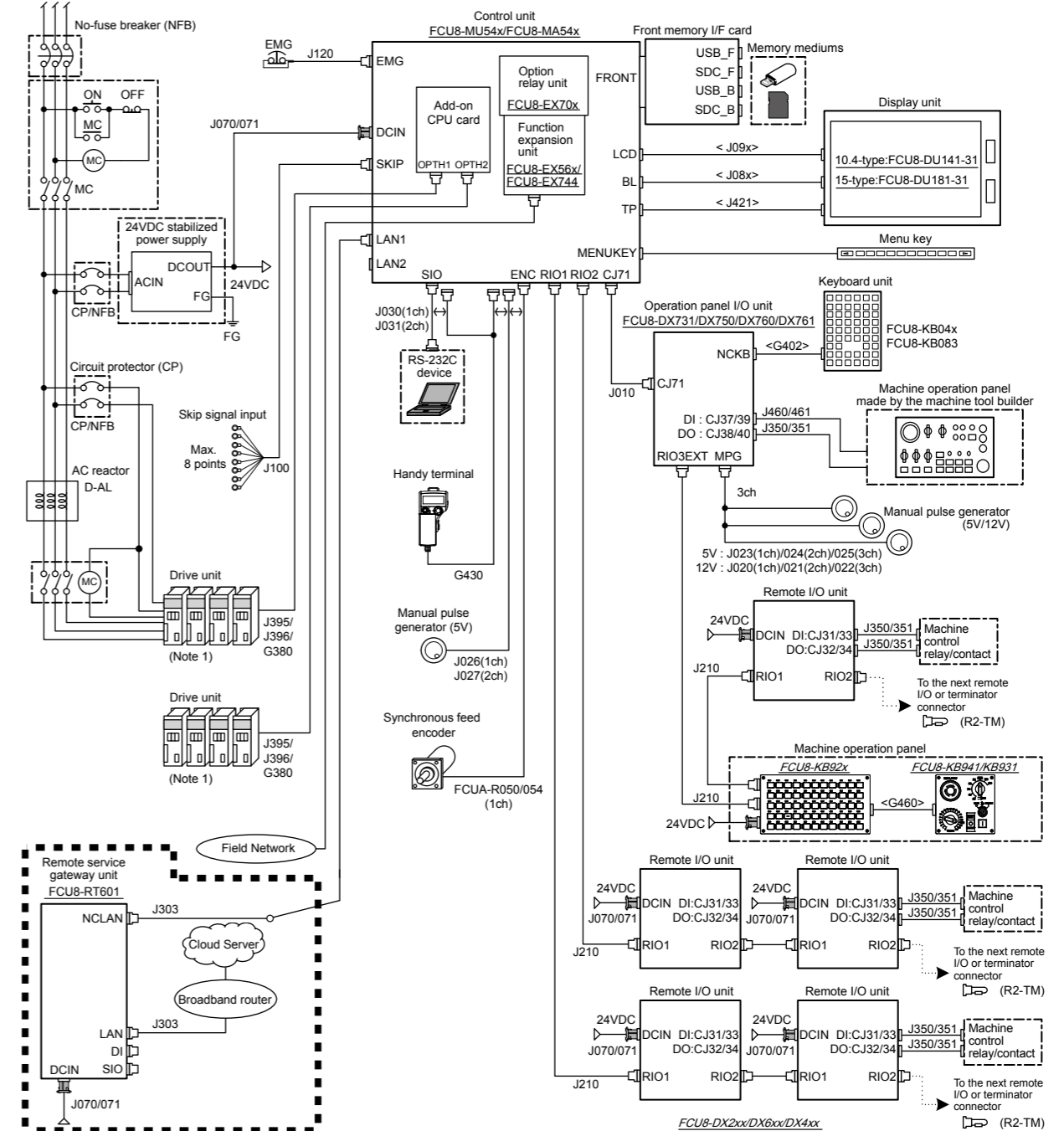

(Note 1) For connections of the drive units, refer to "DRIVE SYSTEM SYSTEM CONFIGURATION DRAWING" described later.
 (Note 2) For details of the cable and the connector, refer to "CNC SYSTEM CABLES LIST" described later.
 (Note 3) For details of a remote service gateway unit, refer to "Remote Service iQ Care Remote4U User's Manual" (IB-1501552).
 (Note 4) Q6BAT can be connected to the control unit for backup use.

■ M800S/M80/E80 Series

(Connection example of an operation panel I/O unit with model number FCU8-DX834)

Example of M800S Series.

□ Dotted lines indicate the sections prepared by the machine tool builder.
 <> Angle brackets indicates attached cable of unit.

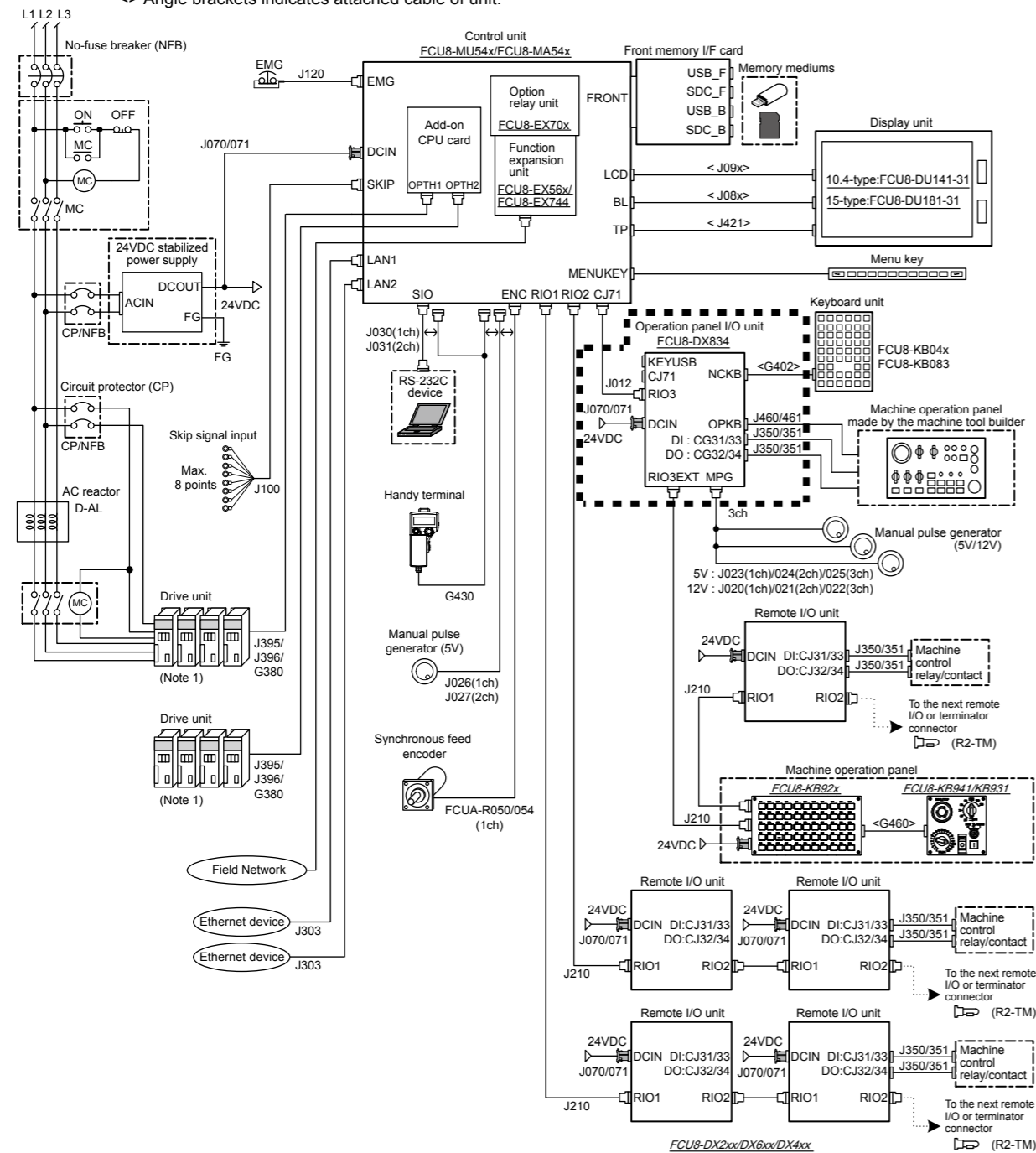

■ C80 Series

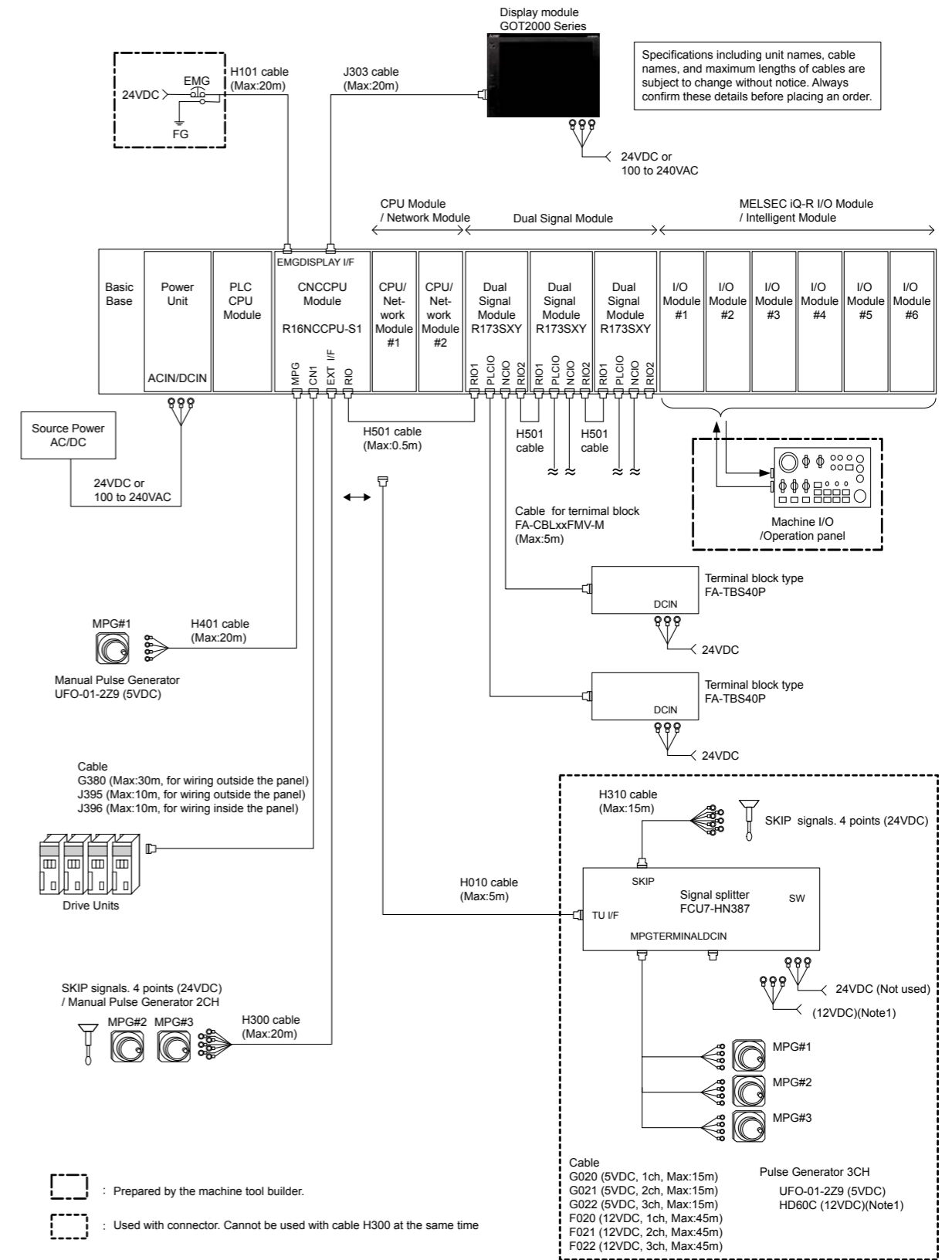

□ : Prepared by the machine tool builder.
 □ : Used with connector. Cannot be used with cable H300 at the same time

Cable
 G020 (5VDC, 1ch, Max:15m)
 G021 (5VDC, 2ch, Max:15m)
 G022 (5VDC, 3ch, Max:15m)
 F020 (12VDC, 1ch, Max:45m)
 F021 (12VDC, 2ch, Max:45m)
 F022 (12VDC, 3ch, Max:45m)

Pulse Generator 3CH
 UFO-01-229 (5VDC)
 HD60C (12VDC)(Note1)

(Note 1) For connections of the drive units, refer to "DRIVE SYSTEM SYSTEM CONFIGURATION DRAWING" described later.
 (Note 2) For details of the cable and the connector, refer to "CNC SYSTEM CABLES LIST" described later.
 (Note 3) Q6BAT can be connected to the control unit for backup use.

(Note 1) HD60C (12VDC) requires another power source 12VDC.
 (Note 2) A CPU module can be mounted on the CPU slot of the base unit or the slot No. 0 to 6. A slot between CPU modules can be left empty for reservation. Note that you cannot mount an I/O module or intelligent function module on a slot between CPU modules.

CNC SYSTEM LIST OF CABLES

[M800/M80/E80 Series]

	Application	Type	Length (m)	Contents	Supported model				
					M800W	M800S	M80W	M80	E80
(1)	Connection cable between personal computer unit and operation panel I/O unit	J291 L0.15M	0.15		○	—	○	—	—
		J291 L0.5M	0.5						
		J291 L1.0M	1						
(2)	24VDC relay cable for MITSUBISHI CNC machine operation panel	G071 L0.12M	0.12		○	○	○	○	○
		G071 L0.5M	0.5						
		G071 L1M	1						
(3)	ON/OFF switch cable (ON/OFF switch - Personal computer unit) (for Windows-based display unit)	G170 L1M	1		○	—	○	—	—
		G170 L2M	2						
		G170 L3M	3						
		G170 L5M	5						
		G170 L10M	10						
		G170 L15M	15						
(4)	Cable for connection to handy terminal	G430 3M	3		○	○	○	○	○
		G430 5M	5						
		G430 10M	10						
(5)	Cable for MITSUBISHI CNC machine operation panel (Cable between main panel and sub panel)	G460 0.5M	0.5		○	○	○	○	○
(6)	ON/OFF switch cable (ON/OFF switch - Graphic control unit) (for non-Windows-based display unit)	J170 L1M	1		○	—	○	—	—
		J170 L2M	2						
		J170 L3M	3						
		J170 L5M	5						
		J170 L10M	10						
		J170 L15M	15						
(7)	Analog output cable	J220 L2M	2		○	—	—	—	—
		J220 L3M	3						
		J220 L7M	7						
(8)	Analog input/output cable (for remote I/O unit)	J221 L2M	2		○	○	○	○	○
		J221 L3M	3						
		J221 L7M	7						
(9)	Analog input/output cable (for operation panel I/O unit)	J224 L1M	1		—	○	—	○	○
		J224 L2M	2						
		J224 L3M	3						
		J224 L5M	5						
		J224 L7M	7						
		J224 L10M	10						
		J224 L15M	15						
J224 L20M	20								
(10)	Analog output cable (for operation panel I/O unit)	J225 L1M	1		—	○	—	○	○
		J225 L2M	2						
		J225 L3M	3						
		J225 L5M	5						
		J225 L7M	7						
		J225 L10M	10						
		J225 L15M	15						
J225 L20M	20								
(11)	Operation panel I/O interface cable (for non-Windows-based display unit of M800W/M80W)	J010 L0.5M (for 8.4/10.4-type display)	0.5		○	○	○	○	○
		J010 L1M	1						
(12)	Manual pulse generator cable (12V) : 1ch	J020 L1M	1		○	○	○	○	○
		J020 L2M	2						
		J020 L3M	3						
		J020 L5M	5						
		J020 L7M	7						
		J020 L10M	10						
		J020 L15M	15						
		J020 L20M	20						
		J020 L30M	30						

	Application	Type	Length (m)	Contents	Supported model												
					M800W	M800S	M80W	M80	E80								
(13)	Manual pulse generator cable (12V) : 2ch	J021 L1M	1		○	○	○	○	○								
		J021 L2M	2														
		J021 L3M	3														
		J021 L5M	5														
		J021 L7M	7														
		J021 L10M	10														
		J021 L15M	15														
		J021 L20M	20														
		J021 L30M	30														
		(14)	Manual pulse generator cable (12V) : 3ch							J022 L1M	1		○	○	○	○	○
J022 L2M	2																
J022 L3M	3																
J022 L5M	5																
J022 L7M	7																
J022 L10M	10																
J022 L15M	15																
J022 L20M	20																
J022 L30M	30																
(15)	Manual pulse generator cable (5V) : 1ch			J023 L1M	1		○	○	○	○	○						
		J023 L2M	2														
		J023 L3M	3														
		J023 L5M	5														
		J023 L7M	7														
		J023 L10M	10														
		J023 L15M	15														
		J023 L20M	20														
		J023 L30M	30														
		(16)	Manual pulse generator cable (5V) : 2ch	J024 L1M	1								○	○	○	○	○
J024 L2M	2																
J024 L3M	3																
J024 L5M	5																
J024 L7M	7																
J024 L10M	10																
J024 L15M	15																
J024 L20M	20																
(17)	Manual pulse generator cable (5V) : 3ch	J025 L1M	1		○	○	○	○	○								
		J025 L2M	2														
		J025 L3M	3														
		J025 L5M	5														
		J025 L7M	7														
		J025 L10M	10														
		J025 L15M	15														
J025 L20M	20																
(18)	Manual pulse generator cable (5V) : 1ch (for connection to control unit)	J026 L1M	1		○	○	○	○	○								
		J026 L2M	2														
		J026 L3M	3														
		J026 L5M	5														
		J026 L7M	7														
		J026 L10M	10														
		J026 L15M	15														
J026 L20M	20																
(19)	Manual pulse generator cable (5V) : 2ch (for connection to control unit)	J027 L1M	1		○	○	○	○	○								
		J027 L2M	2														
		J027 L3M	3														
		J027 L5M	5														
		J027 L7M	7														
		J027 L10M	10														
		J027 L15M	15														
		J027 L20M	20														
		(20)	RS-232C I/F cable: 1ch (for control unit)							J030 L1M	1		○	○	○	○	○
										J030 L2M	2						
J030 L3M	3																
J030 L5M	5																
J030 L7M	7																
J030 L10M	10																
(21)	RS-232C I/F cable: 2ch (for control unit)	J031 L1M	1		○	○	○	○	○								
		J031 L2M	2														
		J031 L3M	3														
		J031 L5M	5														
		J031 L7M	7														
J031 L10M	10																

Application	Type	Length (m)	Contents	Supported model				
				M800W	M800S	M80W	M80	E80
(22) 24VDC power cable	J070 L1M	1		○	○	○	○	○
	J070 L2M	2						
	J070 L3M	3						
	J070 L5M	5						
	J070 L7M	7						
	J070 L10M	10						
	J070 L15M	15						
(23) SKIP input cable	J100 L1M	1		○	○	○	○	○
	J100 L2M	2						
	J100 L3M	3						
	J100 L5M	5						
	J100 L7M	7						
	J100 L10M	10						
	J100 L15M	15						
(24) Emergency stop cable	J120 L1M	1		○	○	○	○	○
	J120 L2M	2						
	J120 L3M	3						
	J120 L5M	5						
	J120 L7M	7						
	J120 L10M	10						
	J120 L15M	15						
	J120 L20M	20						
	J120 L30M	30						
	(25) Emergency stop cable for MITSUBISHI CNC machine operation panel	J121 L1M						
J121 L2M		2						
J121 L3M		3						
J121 L5M		5						
J121 L7M		7						
J121 L10M		10						
J121 L15M		15						
J121 L20M		20						
J121 L30M		30						
(26) Remote I/O 2.0 communication cable		J210 L0.3M	0.3		○	○	○	○
	J210 L1M	1						
	J210 L2M	2						
	J210 L3M	3						
	J210 L5M	5						
	J210 L7M	7						
	J210 L10M	10						
	J210 L15M	15						
	J210 L20M	20						
	J210 L30M	30						
(27) LAN straight cable	J303 L1M	1		○	○	○	○	○
	J303 L2M	2						
	J303 L3M	3						
	J303 L5M	5						
	J303 L7M	7						
	J303 L10M	10						
	J303 L15M	15						
	J303 L20M	20						
J303 L30M	30							
(28) DI/DO cable (connectors at both ends)	J350 L1M	1		○	○	○	○	○
	J350 L2M	2						
	J350 L3M	3						
	J350 L5M	5						
(29) DI/DO cable (connector at one end)	J351	3		○	○	○	○	○
(30) DI/DO cable (connectors at both ends) (for operation panel I/O unit)	J460 L1M	1		—	○	—	○	○
	J460 L2M	2						
	J460 L3M	3						
	J460 L5M	5						
(31) DI/DO cable (connector at one end) (for operation panel I/O unit)	J461	3		—	○	—	○	○

Application	Type	Length (m)	Contents	Supported model				
				M800W	M800S	M80W	M80	E80
(32) Synchronous encoder - control unit (straight, with connector) (for FCU8-EX544 (M800W/M80W))	FCUA-R050-5M	5		○	○	○	○	○
(33) Synchronous encoder - control unit (right angle, with connector) (for FCU8-EX544 (M800W/M80W))	FCUA-R054-3M	3		○	○	○	○	○
	FCUA-R054-5M	5						
	FCUA-R054-10M	10						
	FCUA-R054-15M	15						
(34) Cable for emergency stop release	G123	—		○	○	○	○	○
(35) Terminator for remote I/O interface	R2-TM	—		○	○	○	○	○

One terminator is required to be installed at the final end of remote IO unit.

■ Cable connector sets for CNC

Application	Type	Contents	Supported model					
			M800W	M800S	M80W	M80	E80	
(1) General I/O units (for SKIP,SIO,MPG,AIO)	FCUA-CS000	Connector (3M) 10120-3000PE x 2pcs. 	Shell kit (3M) 10320-52F0-008 x 2pcs. 	○	○	○	○	○
(2) Emergency stop connector (for EMG)	005057-9403 16-02-0103	Connector (MOLEX) 50-57-9403 x 1pc. 	Gold contact (MOLEX) 16-02-0103 x 3pcs. 	○	○	○	○	○
(3) Connector kit for RIO2.0 unit	RIO2 CON	Connector (Tyco Electronics) 1-1318119-3 x 2pcs. 	Contact (Tyco Electronics) 1318107-1 x 8pcs. 	○	○	○	○	○
		Connector (Tyco Electronics) 2-178288-3 x 1pc. 	Contact (Tyco Electronics) 1-175218-5 x 3pcs. 					
(4) 24VDC power supply connector (for DCIN)	FCUA-CN220	Connector (Tyco Electronics) 2-178288-3 x 1pc. 	Contact (Tyco Electronics) 1-175218-5 x 3pcs. 	○	○	○	○	○
(5) DI/DO connector (for operation panel I/O unit) (for remote I/O unit)	7940-6500SC 3448-7940	Connector (3M) 7940-6500SC x 4pcs. 	Strain relief (3M) 3448-7940 x 4pcs. 	○	○	○	○	○
(6) DI connector (for operation panel I/O unit)	7950-6500SC 3448-7950	Connector (3M) 7950-6500SC x 2pcs. 	Strain relief (3M) 3448-7950 x 2pcs. 	○	○	○	○	○
(7) ON/OFF switch connector	005057-9404 16-02-0103	Connector (MOLEX) 50-57-9404 x 1pc. 	Contact (MOLEX) 16-02-0103 x 4pcs. 	○	—	○	—	—
(8) CJ71 connector	2-1318119-4 1318107-1	Connector (Tyco Electronics) 2-1318119-4 x 1pc. 	Contact (Tyco Electronics) 1318107-1 x 8pcs. 	—	○	—	○	○
(9) THERMISTOR connector (for thermistor input unit)	37104-2165-000FL 10P	Connector (3M) 37104-2165-000FL x 10pcs. 		○	○	○	○	○

[C80 Series]

Application	Type	Length (m)	Contents	Supported model				
					(1) Emergency stop cable	H101 L0.5M H101 L1M H101 L2M H101 L3M H101 L5M H101 L7M H101 L10M H101 L15M H101 L20M	0.5 1 2 3 5 7 10 15 20	
(2) Display communication cable (Shielded twisted pair cable)	J303 L1M J303 L2M J303 L3M J303 L5M J303 L10M J303 L15M J303 L20M	1 2 3 5 10 15 20		Display interface, maximum length: 20m				
	(3) Skip/manual pulse generator input cable (For CNC CPU unit)	H300 L0.5M H300 L1M H300 L2M H300 L3M H300 L5M H300 L7M H300 L10M H300 L15M H300 L20M	0.5 1 2 3 5 7 10 15 20		Skip/manual pulse generator input interface, maximum length: 20m (Note) This cable cannot be used together with the H010 cable.			
		(4) Skip input cable (For signal splitter)	H310 L0.5M H310 L1M H310 L2M H310 L3M H310 L5M H310 L7M H310 L10M H310 L15M	0.5 1 2 3 5 7 10 15		Skip input interface when signal splitter is used, maximum length: 15m		
			(5) Manual pulse generator cable (For CNC CPU unit)	H401 L0.5M H401 L1M H401 L2M H401 L3M H401 L5M H401 L7M H401 L10M H401 L15M H401 L20M	0.5 1 2 3 5 7 10 15 20		Manual pulse generator (1ch), maximum length: 20m (5V power supply type)	
				(6) Safety signal unit connection cable	H501 L0.1M H501 L0.2M H501 L0.3M H501 L0.5M	0.1 0.2 0.3 0.5		Between safety signal units, maximum length: 0.5m
					(7) Signal splitter connection cable	H010 L0.5M H010 L1M H010 L2M H010 L3M H010 L5M	0.5 1 2 3 5	

MEMO

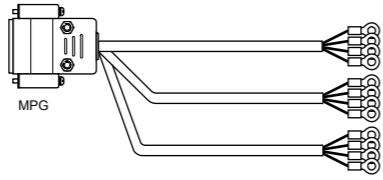
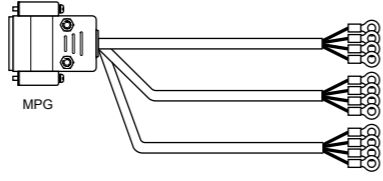
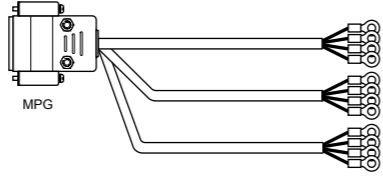
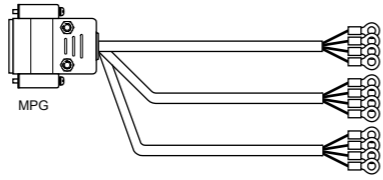
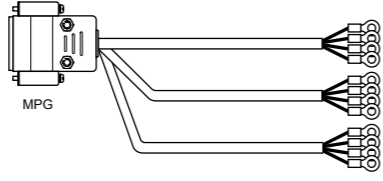
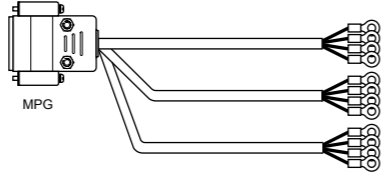
Application	Type	Length (m)	Contents	Supported model
(8) Manual pulse generator cable (For signal splitter)	F020 L0.5M	0.5		Manual pulse generator (1ch), maximum length: 45m (12V power supply type) 12V power supply separately necessary
	F020 L1M	1		
	F020 L2M	2		
	F020 L3M	3		
	F020 L5M	5		
	F020 L7M	7		
	F020 L10M	10		
	F020 L15M	15		
(9) Manual pulse generator cable (For signal splitter)	F021 L0.5M	0.5		Manual pulse generator (2ch), maximum length: 45m (12V power supply type) 12V power supply separately necessary
	F021 L1M	1		
	F021 L2M	2		
	F021 L3M	3		
	F021 L5M	5		
	F021 L7M	7		
	F021 L10M	10		
	F021 L15M	15		
(10) Manual pulse generator cable (For signal splitter)	F022 L0.5M	0.5		Manual pulse generator (3ch), maximum length: 45m (12V power supply type) 12V power supply separately necessary
	F022 L1M	1		
	F022 L2M	2		
	F022 L3M	3		
	F022 L5M	5		
	F022 L7M	7		
	F022 L10M	10		
	F022 L15M	15		
(11) Manual pulse generator cable (For signal splitter)	G020 L0.5M	0.5		Manual pulse generator (1ch), maximum length: 15m (5V power supply type)
	G020 L1M	1		
	G020 L2M	2		
	G020 L3M	3		
	G020 L5M	5		
	G020 L7M	7		
	G020 L10M	10		
	G020 L15M	15		
(12) Manual pulse generator cable (For signal splitter)	G021 L0.5M	0.5		Manual pulse generator (2ch), maximum length: 15m (5V power supply type)
	G021 L1M	1		
	G021 L2M	2		
	G021 L3M	3		
	G021 L5M	5		
	G021 L7M	7		
	G021 L10M	10		
	G021 L15M	15		
(13) Manual pulse generator cable (For signal splitter)	G022 L0.5M	0.5		Manual pulse generator (3ch), maximum length: 15m (5V power supply type)
	G022 L1M	1		
	G022 L2M	2		
	G022 L3M	3		
	G022 L5M	5		
	G022 L7M	7		
	G022 L10M	10		
	G022 L15M	15		

DRIVE SYSTEM

•Drive units



High-performance Servo/ Spindle Drive Units MDS-E/EH Series

- The servo control-dedicated core processor realizes improved control speed, leading to enhanced basic performance. When combined with a higher resolution motor sensor and advanced high-speed optical communication, this drive contributes to high-speed, high-accuracy control.
- The motor power connector is equipped with an anti-misinsertion mechanism. This helps to eliminate connection errors.
- Improved diagnostic and preventive-maintenance features
- Safe Torque Off (STO) and Safe Brake Control (SBC) are also incorporated as additional safety features.

Multi-hybrid Drive Units MDS-EM/EMH Series

- The multi-hybrid drive units are capable of driving a maximum of three servo axes and one spindle. This contributes to the downsizing of machines and offers technical advantages.
- The motor power connector is equipped with an anti-misinsertion mechanism. This helps to eliminate connection errors.
- Safe Torque Off (STO) and Safe Brake Control (SBC) are also incorporated as additional safety features.
- Fan unit contributes to easier fan exchange
- MDS-EMH 400V system drive unit is available.

All-in-one Compact Drive Units MDS-EJ/EJH Series

- Ultra-compact drive units with built-in power supplies contribute to smaller control panel size.
- The 2-axis type is added for further downsizing.
- The servo control-dedicated core processor realizes an increase in control speed, leading to improved basic performance. When combined with a higher resolution motor sensor and enhanced high-speed optical communication, this drive contributes to high-speed, high-accuracy control.
- Safe Torque Off (STO) and Safe Brake Control (SBC) are also incorporated as additional safety features.
- MDS-EJH 400V system drive unit is available (Note 1).

PWM Converter MDS-EX-CVP Series

- Product of the PWM converter series which has a stabilizing DC voltage function and boost function. MDS-EX-CVP series reduces the output deceleration of the spindle motor and improves output in the high-speed range.
- Only 400V system power supply unit is available.

•Servo motors



Medium-inertia, High-accuracy, High-speed Motors HG Series

- Sensor resolution has been significantly improved. The servo motors, which boast smooth rotation and outstanding acceleration capabilities, are well-suited to serve as feed axes of machine tools.
- Range: 0.2 to 11 [kW]
- Maximum rotation speed: 2,000 to 6,000 [r/min]
- Safety support sensors are included as standard specification. Sensor connectors are screw-locked and have enhanced vibration resistance. Three sensor resolutions (i.e., 1, 4 or 67 million pulses/rev) are available.
- This can also be used as a tool spindle motor.
- Small-sized connector allows horizontal cable connection, which helps to save space in machines. (Note 2)

Linear Servo Motors LM-F Series

- Use in clean environments is possible since no ball screws are used, eliminating possible contamination from grease.
- Elimination of transmission mechanisms, including backlash, enables smooth, quiet operation even at high speeds.
- Range: Maximum thrust: 900 to 18,000 [N·m]

Direct-drive Servo Motors TM-RB Series

- High-torque, direct-drive motors combined with high-gain control provide quick acceleration and positioning, which makes rotation smoother.
- Suitable for rotary axes that drive tables or spindle heads
- Range: Maximum torque: 36 to 1,280 [N·m]



•Spindle motors



High-output, High-speed Spindle Motors SJ-DG Series

- Addition of S3 rating (%ED rating) has improved output and torque acceleration/deceleration characteristics.
- Balance adjustment ring added to the counter-load side for fine tuning.
- Range: S3 rating: 5.5 to 15 [kW]
- Maximum speed: 10,000 to 12,000 [r/min]

Low-inertia, High-speed Spindle Motors SJ-DL Series

- This series of spindle motors is dedicated to use in tapping machines that require faster drilling and tapping.
- The latest design technologies have made it possible to attain lower vibration and greater rigidity even with the lighter weight.
- Range: 0.75 to 7.5 [kW]
- Maximum speed: 10,000 to 24,000 [r/min]

High-performance Spindle Motors SJ-D Series

- Motor energy loss has been significantly reduced by optimizing the magnetic circuit.
- High-speed bearings are incorporated as a standard feature, helping to achieve higher speed, lower vibration and improved durability.
- Range: 3.7 to 26 [kW]
- Maximum speed: 8,000 to 12,000 [r/min]

High-torque Spindle Motors SJ-DN Series

- Higher torque characteristics than those of SJ-D series with the same output. This series has made it possible to drive with the small-capacity multi-hybrid drive unit.
- Suitable for heavy cutting. This helps to improve productivity.
- Range: 7.5 to 18.5 [kW]
- Maximum speed: 8,000 [r/min]

Compact, Lightweight Spindle Motors SJ-DJ Series

- Spindle motors that are smaller and lighter than those of SJ-D series with the same output. This helps to further downsize machines.
- Range: 5.5 to 15 [kW]
- Maximum speed: 8,000 to 12,000 [r/min]

High-output high-torque IPM spindle motor SJ-DM Series

- The use of magnets allows for a higher output and torque, leading to a reduced cycle time.
- SJ-DM Series can provide torque characteristics comparable to the former SJ-D Series of the next frame number.
- Maximum rotation speed: 12,000 [r/min]



Built-in Spindle Motors SJ-BG Series

- The electrical design has been optimized to increase the continuous rated torque per unit volume, contributing to the downsizing of spindle units.
- Options for mold specification and cooling jacket specification are prepared.

Tool Spindle Motors HG-JR Series

- Compact tool spindle motors are designed to have the small, high-output characteristics of servo motors yet offer high-speed rotation (8,000r/min). These motors contribute to downsizing spindle size, like rotary tool spindles.
- Range: 0.75 to 1.5 [kW]
- Maximum rotation speed: 8,000 [r/min]
- Small-sized connector allows horizontal cable connection, which helps to save space in machines. (Note 2)

(Note 1) For servo motors only
(Note 2) Options supported (Flange size 90SQ only)
* Use Mitsubishi Electric CNC's dedicated drive unit and motor.

SYSTEM CONFIGURATION

■MDS-E/EH Series

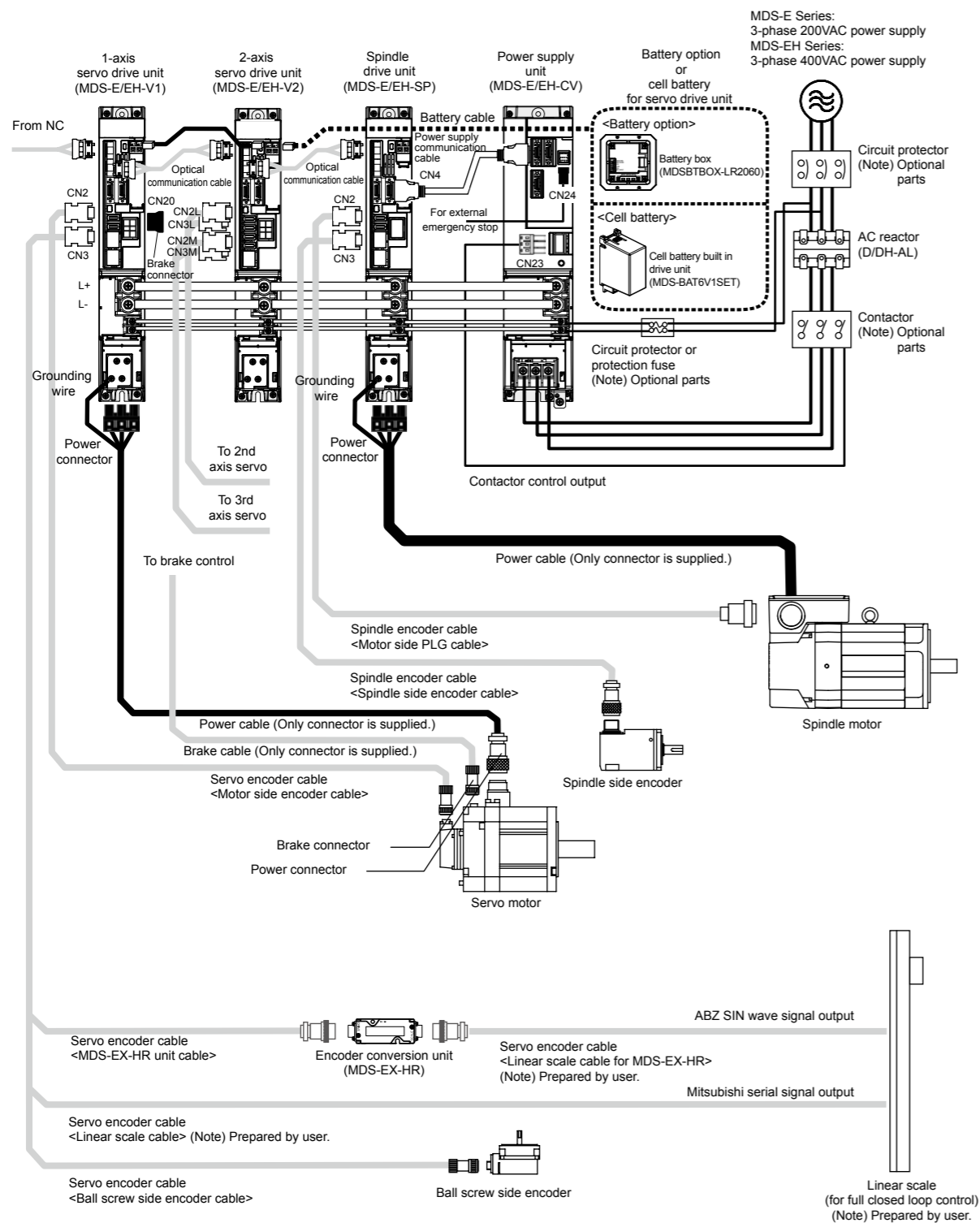

■MDS-EM/EMH Series

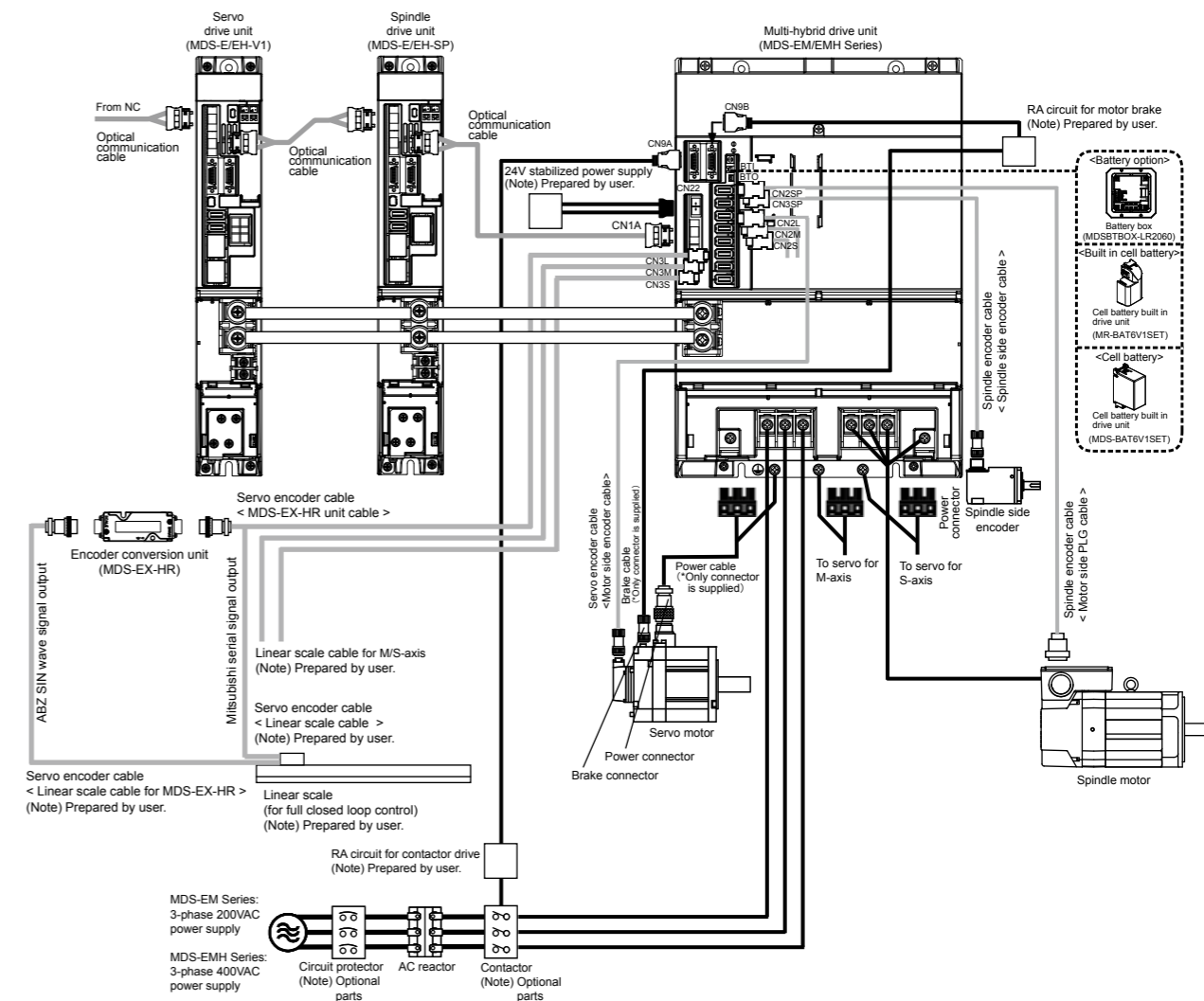

■ MDS-EJ/EJH Series

MDS-EJ Series:
3-phase 200VAC power supply
MDS-EJH Series:
3-phase 400VAC power supply (MDS-EJH-V1 only)

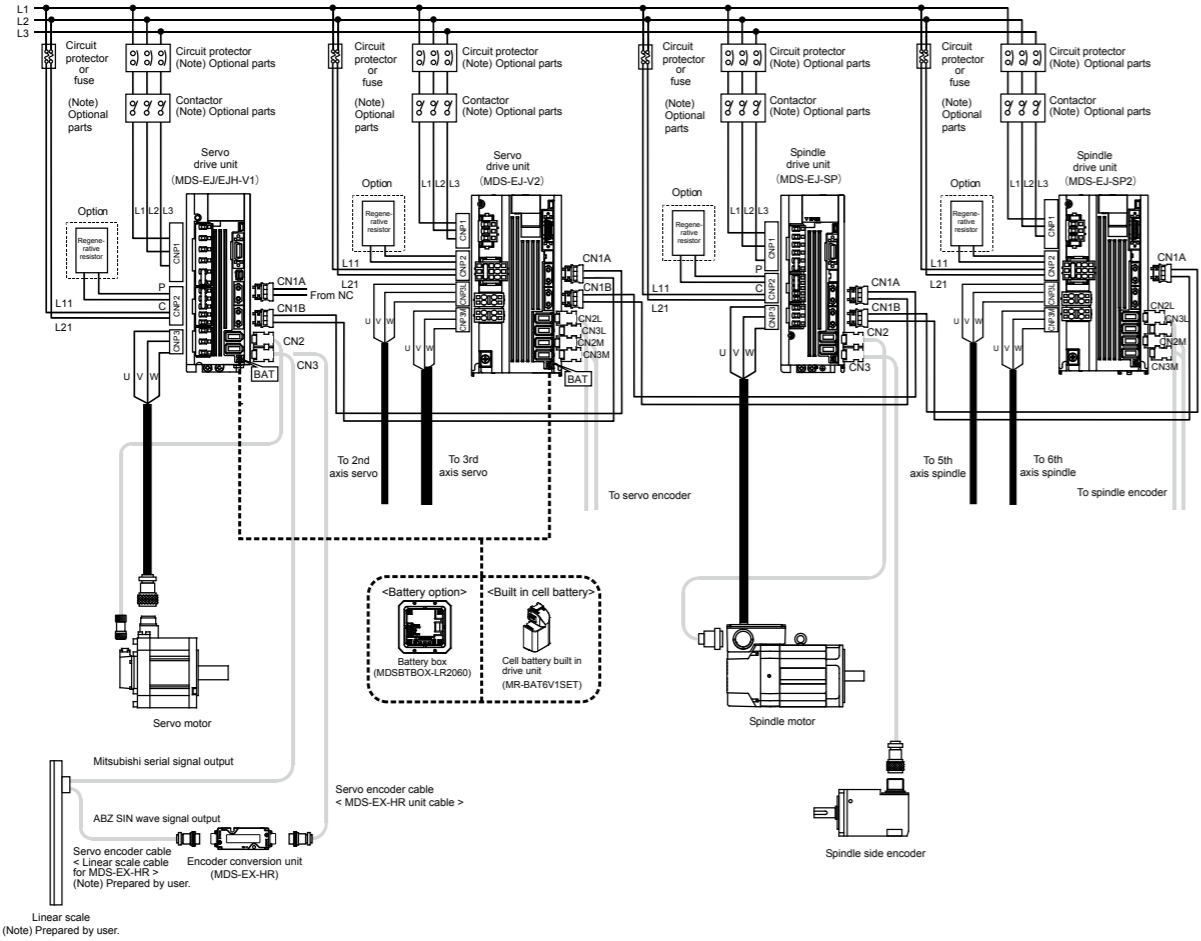

<For single-phase power supply>

MDS-EJ Series:
Single-phase 200VAC power supply

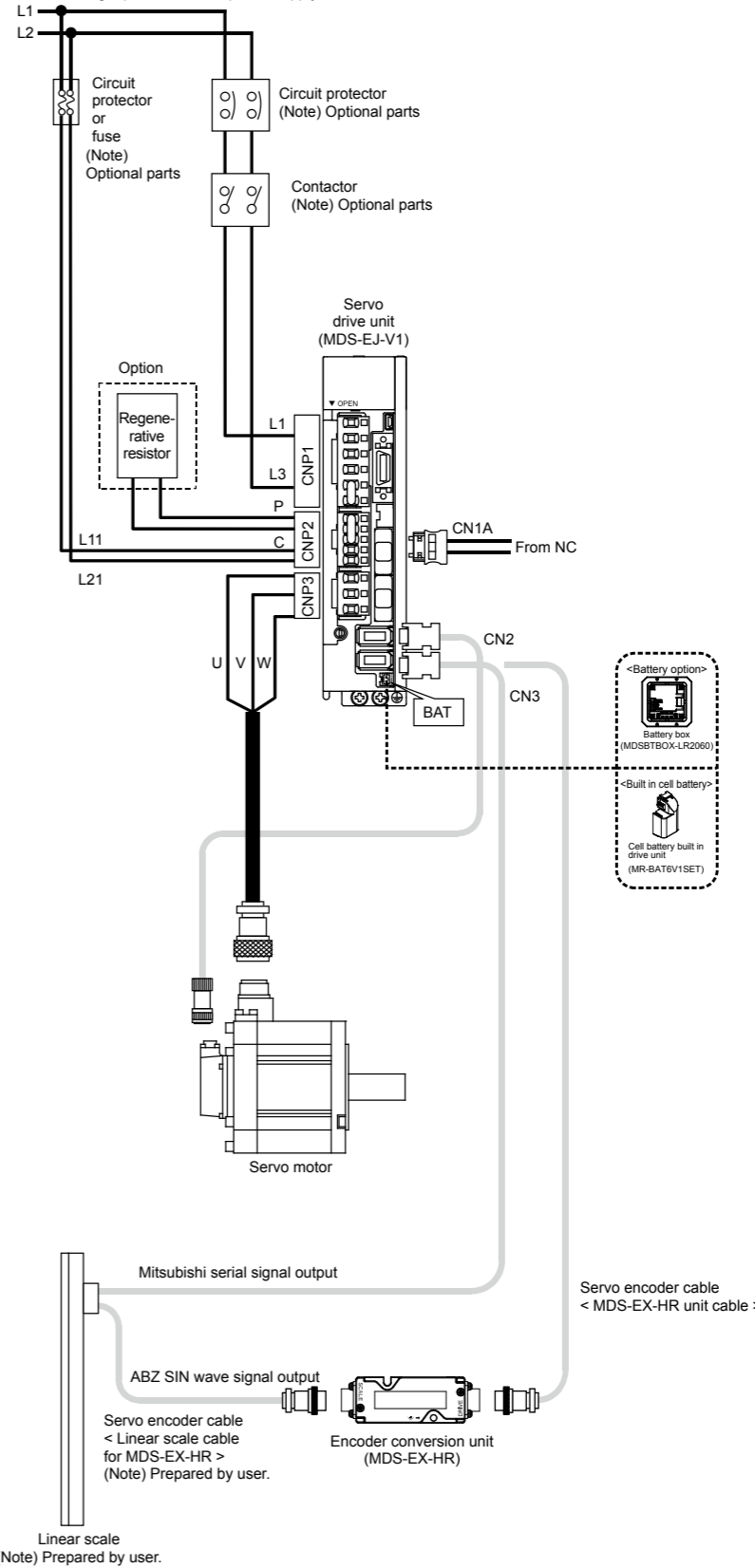

When using the battery box <MDSBTBOX-LR2060>

< Parallel connection >

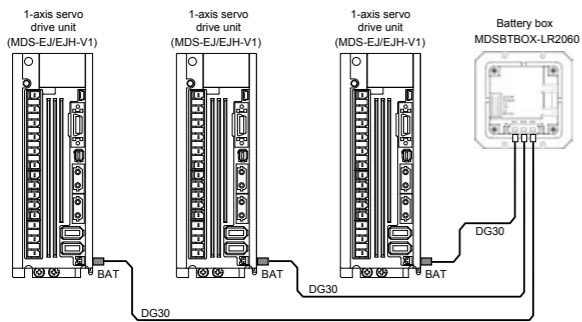

< Daisy-chain connection >

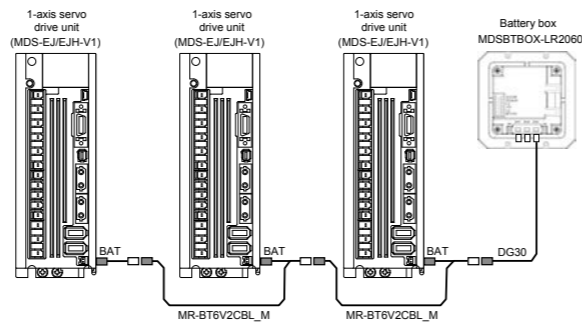

■MDS-EX-CVP Series

■MEMO

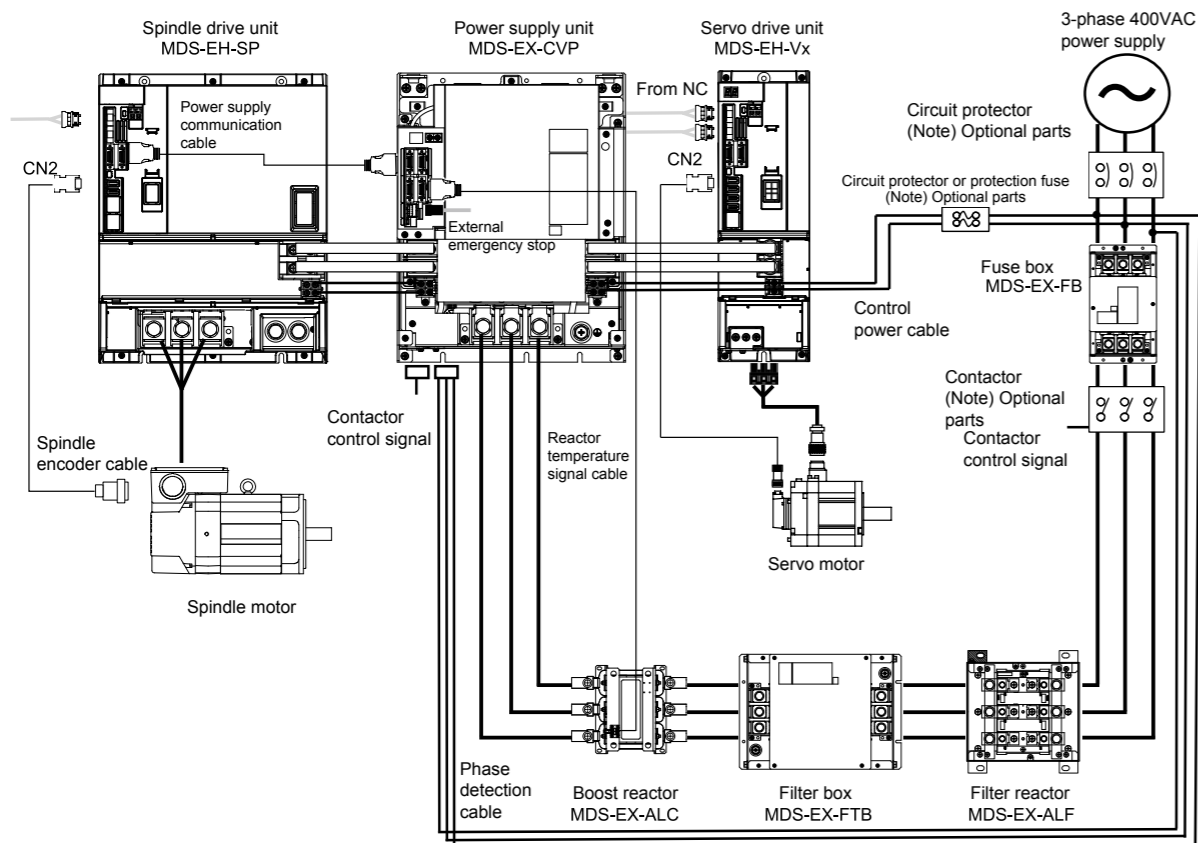

SPECIFICATIONS

<Servo specification>

Item	MDS-E-V1/V2/V3	MDS-EH-V1/V2	MDS-EM/EMH-SPV3	MDS-EJ/EJH-V1	MDS-EJ-V2	
1 Base control functions	1.1 Full closed loop control	●	●	●	●	
	1.2 Position command synchronous control	●	●	●	●	
	1.3 Speed command synchronous control	● (Note 1)	●	●	●	
	1.4 Distance-coded reference position control	●	●	●	●	
2 Servo control function	2.1 Torque limit function (stopper function)	●	●	●	●	
	2.2 Variable speed loop gain control	●	●	●	●	
	2.3 Gain changeover for synchronous tapping control	●	●	●	●	
	2.4 Speed loop PID changeover control	●	●	●	●	
	2.5 Disturbance torque observer	●	●	●	●	
	2.6 Smooth High Gain control (SHG control)	●	●	●	●	
	2.7 High-speed synchronous tapping control (OMR-DD control)	●	●	●	●	
	2.8 Dual feedback control	●	●	●	●	
	2.9 HAS control	●	●	●	●	
	2.10 OMR-FF control	●	●	●	●	
3 Compensation control function	3.1 Jitter compensation	●	●	●	●	
	3.2 Notch filter	Variable frequency: 4 Fixed frequency: 1	Variable frequency: 4 Fixed frequency: 1	Variable frequency: 4 Fixed frequency: 1	Variable frequency: 4 Fixed frequency: 1	Variable frequency: 4 Fixed frequency: 1
	3.3 Adaptive tracking-type notch filter	●	●	●	●	●
	3.4 Overshooting compensation	●	●	●	●	●
	3.5 Machine end compensation control	●	●	●	●	●
	3.6 Lost motion compensation type 2	●	●	●	●	●
	3.7 Lost motion compensation type 3	●	●	●	●	●
	3.9 Real-time tuning I	●	●	●	●	●
	3.10 Full-closed torsion compensation function	●	●	●	●	●
	4 Protection function	4.1 Deceleration control at emergency stop	●	●	●	●
4.2 Vertical axis drop prevention/pull-up control		●	●	●	●	
4.3 Earth fault detection		●	●	●	●	
4.4 Collision detection function		●	●	●	●	
4.5 Fan stop detection		●	●	●	●	
4.8 STO (Safe Torque Off) function		●	●	● (Note 2)	●	
4.9 SBC (Safe Brake Control) function		●	●	●	●	
4.10 Deceleration and stop function at power failure (Note 3)		●	●	●	●	
4.11 Retraction function at power failure (Note 4)		●	●	●	●	
5 Sequence function		5.2 Motor brake control function	●	●	●	●
		5.4 Specified speed output	●	●	●	●
	5.5 Quick READY ON sequence	●	●	●	●	
6 Diagnosis function	6.1 Monitor output function	●	●	●	●	
	6.2 Machine resonance frequency display function	●	●	●	●	
	6.3 Machine inertia display function	●	●	●	●	

(Note 1) Always set L-axis as primary axis and M-axis as secondary axis for the speed command synchronous control using MDS-E-V3. Other settings cause the initial parameter error alarm.
 (Note 2) The dedicated wiring STO is not supported by MDS-EM/EMH Series.
 (Note 3) The power backup unit and resistor unit option are required.
 (Note 4) The power backup unit and capacitor unit option are required.

<Spindle specification>

Item	MDS-E/EH-SP	MDS-E-SP2	MDS-EM/EMHSPV3	MDS-EJ-SP	MDS-EJ-SP2	
1 Base control functions	1.1 Full closed loop control	●	●	●	●	
	1.5 Spindle's continuous position loop control	●	●	●	●	
	1.6 Coil changeover control	●	●	●	●	
	1.7 Gear changeover control	●	●	●	●	
	1.8 Orientation control	●	●	●	●	
	1.9 Indexing control	●	●	●	●	
	1.10 Synchronous tapping control	●	●	●	●	
	1.11 Spindle synchronous control	●	●	●	●	
	1.12 Spindle/C axis control	●	●	●	●	
	1.13 Proximity switch orientation control	●	● (Note 1)	●	● (Note 1)	
	2 Spindle control functions	2.1 Torque limit function	●	●	●	●
		2.2 Variable speed loop gain control	●	●	●	●
		2.5 Disturbance torque observer	●	●	●	●
2.6 Smooth High Gain control (SHG control)		●	●	●	●	
2.7 High-speed synchronous tapping control (OMR-DD control)		●	●	●	●	
2.8 Dual feedback control		●	●	●	●	
2.10 OMR-FF control		●	●	●	●	
2.11 Control loop gain changeover		●	●	●	●	
2.12 Spindle output stabilizing control		●	●	●	●	
2.13 High-response spindle acceleration/deceleration function		●	●	●	●	
3 Compensation control function	3.1 Jitter compensation	●	●	●	●	
	3.2 Notch filter	Variable frequency: 4 Fixed frequency: 1	Variable frequency: 4 Fixed frequency: 1	Variable frequency: 4 Fixed frequency: 1	Variable frequency: 4 Fixed frequency: 1	
	3.3 Adaptive tracking-type notch filter	●	●	●	●	
	3.4 Overshooting compensation	●	●	●	●	
	3.6 Lost motion compensation type 2	●	●	●	●	
	3.8 Spindle motor temperature compensation function	●	●	●	●	
4 Protection function	4.1 Deceleration control at emergency stop	●	●	●	●	
	4.3 Earth fault detection	●	●	●	●	
	4.5 Fan stop detection	●	●	●	●	
	4.8 STO (Safe Torque Off) function	●	●	● (Note 2)	●	
	4.10 Deceleration and stop function at power failure (Note 3)	●	●	●	●	
	4.11 Retraction function at power failure (Note 4)	●	●	●	●	
	5 Sequence functions	5.4 Specified speed output	●	●	●	●
		5.5 Quick READY ON sequence	●	●	●	●
	6 Diagnosis functions	6.1 Monitor output function	●	●	●	●
		6.2 Machine resonance frequency display function	●	●	●	●
		6.3 Machine inertia display function	●	●	●	●
6.4 Motor temperature display function		●	●	●	●	
6.5 Load monitor output function		●	●	●	●	

(Note 1) As for 2-axis spindle drive unit, setting is available only for one of the axes.
 (Note 2) The dedicated wiring STO is not supported by MDS-EM/EMH Series.
 (Note 3) The power backup unit and resistor unit option are required.
 (Note 4) The power backup unit and capacitor unit option are required.

<Power Supply>

Item	MDS-E-CV	MDS-EH-CV	MDS-EM/EMH-SPV3 built-in converter	MDS-EJV1/V2 built-in converter	MDS-EJH-V1 built-in converter	MDS-EJSP/SP2 built-in converter	MDS-EX-CVP Series
1 Base control functions	1.14 Power regeneration control	●	●	●	●	●	●
	1.15 Resistor regeneration control	●	●	●	●	●	●
4 Protection function	1.16 PWM control	●	●	●	●	●	●
	4.5 Fan stop detection	●	●	●	●	●	●
	4.6 Open-phase detection	●	●	●	●	●	●
	4.7 Contactor weld detection	●	●	●	●	●	●
	4.10 Deceleration and stop function at power failure (Note 1)	●	●	●	●	●	●
	4.11 Retraction function at power failure (Note 2)	●	●	●	●	●	●
	5 Sequence function	5.1 Contactor control function	●	●	●	●	●
5.3 External emergency stop function		●	●	●	●	●	●
5.5 High-speed READY ON sequence		●	●	●	●	●	●
6 Diagnosis function	6.6 Power supply diagnosis display function	●	●	●	●	●	●
	6.7 Drive unit diagnosis display function	●	●	●	●	●	●

(Note 1) The power backup unit and resistor unit option are required.
 (Note 2) The power backup unit and capacitor unit option are required.

■ MITSUBISHI CNC DRIVE SYSTEM LINES

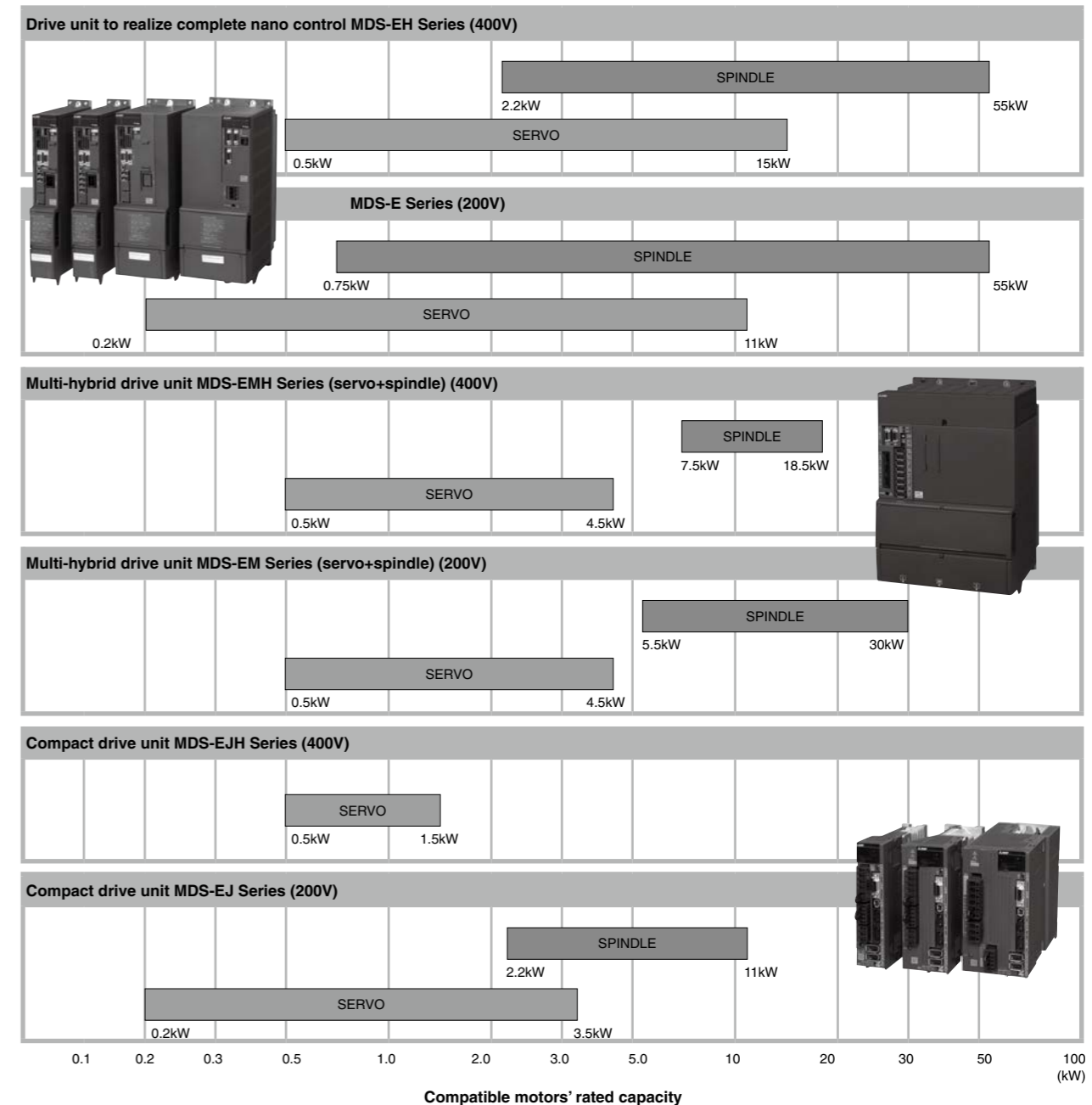

TYPE

200V HG servo motor

<HG Series>
 HG ① ② ③ - ④ - ⑤

① **Rated output and maximum rotation speed**

Symbol	Rated output	Max. rotation speed	Flange size (mm)
46	0.2 kW	6000 r/min	60 SQ.
56	0.4 kW	6000 r/min	60 SQ.
96	0.75 kW	6000 r/min	80 SQ.
75	0.75 kW	5000 r/min	90 SQ.
105	1.0 kW	5000 r/min	90 SQ.
54	0.5 kW	4000 r/min	130 SQ.
104	1.0 kW	4000 r/min	130 SQ.
154	1.5 kW	4000 r/min	130 SQ.
224	2.2 kW	4000 r/min	130 SQ.
204	2.0 kW	4000 r/min	176 SQ.
354	3.5 kW	4000 r/min	176 SQ.
123	1.2 kW	3000 r/min	130 SQ.
223	2.2 kW	3000 r/min	130 SQ.
303	3.0 kW	3000 r/min	176 SQ.
453	4.5 kW	3500 r/min	176 SQ.
603	6.0 kW	3000 r/min	176 SQ.
702	7.0 kW	2000 r/min	176 SQ.
703	7.0 kW	3000 r/min	176 SQ.
903	9.0 kW	3000 r/min	204 SQ.
1103	11.0 kW	3000 r/min	220 SQ.
142	1.4 kW	2000 r/min	130 SQ.
302	3.0 kW	2000 r/min	176 SQ.

② **Magnetic brake**

Symbol	Magnetic brake
None	None
B	With magnetic brake

③ **Shaft end structure**

Symbol	Shaft end structure
K	With keyway (with key)
S	Straight
T	Taper

(Note 1) "Taper" is available for the motor whose flange size is 90 SQ. mm or 130 SQ. mm.
 (Note 2) "K: With keyway (with key)" is only available for HG46/56/96.

④ **Power connector**

Symbol	Connector
None	Normal
S105010	Compact (horizontal direction)

(Note) S105010 can only be used with HG75/105.

⑤ **Encoder**

Symbol	Type	Detection method	Resolution
D47	OSA24RS-120	Absolute position	1,048,576 p/rev
D48	OSA24RS		1,048,576 p/rev
D51	OSA405S5AS		4,194,304 p/rev
D74	OSA676S5AS		67,108,864 p/rev

(Note) Encoder D47 can only be used with HG46/56/96.

200V Direct-drive motor

<TM-RB Series>
 Primary side [coil side] TM-RBP ① ② ③
 Secondary side [magnet side] TM-RBS ① ② ③

① **Rated torque**

Symbol	Rated torque
012	12 N·m
036	36 N·m
048	48 N·m
105	105 N·m
150	150 N·m
340	340 N·m
500	500 N·m

② **Stator dimensions**

Symbol	Dimension
C	DIA 130 mm
E	DIA 180 mm
G	DIA 230 mm
J	DIA 330 mm

③ **Rated rotation speed**

Symbol	Speed
10	100 r/min
20	200 r/min

(Note) This explains the model name system of a direct-drive motor, and all combinations of motor types listed above do not exist.

200V Linear servo motor

<LM-F Series>
 Primary side [coil side] LM-FP ① ② - ③ M-1WW0
 Secondary side [magnet side] LM-FS ① 0- ② -1WW0

① **Width**

Symbol	Width (nominal)
2	120 mm
4	200 mm

② **Length**

Symbol	Length (nominal)
A	170 mm
B	290 mm
D	530 mm
F	770 mm
H	1010 mm

③ **Rated thrust**

Symbol	Rated thrust
03	300 N
06	600 N
12	1200 N
18	1800 N
24	2400 N
36	3600 N
48	4800 N

④ **Width**

Symbol	Width (nominal)
2	120 mm
4	200 mm

⑤ **Length**

Symbol	Length (nominal)
384	384 mm
480	480 mm
576	576 mm

(Note) The linear dimension of 384mm is available for LM-FS20 only.

(Note) This explains the model name system of a linear servo motor, and all combinations of motor types listed above do not exist.

SPINDLE MOTOR WITH FRAME LINES

Series	Feature	Application	Specifications
SJ-D	Standard specifications with general-purpose capabilities	Machining center Lathe	Flange type Flange type (hollow shaft) Type with leg
SJ-DG	High-output and high-speed specifications with S3 rating added	Machining center	
SJ-DN	High-torque specifications with lower base rotation speed	Machining center Lathe	
SJ-DL	Lower rotor inertia and higher acceleration/deceleration output	Tapping	Flange type Type with leg
SJ-DJ	Compact & lightweight specifications suitable for popular machines	Machining center Lathe	

200V Spindle with frame

<SJ-D/DG/DJ/DL/DN Series> SJ-D ① ② / ③ - ④ ⑤ - ⑥

① **Series**

Symbol	Series
None	Normal specifications
G	High-output specifications
J	Compact & lightweight specifications
L	Low-inertia specifications
N	High-torque specifications

② **Short-time (or %ED) rated output**

Symbol	Short-time rated output
0.75	0.75 kW
1.5	1.5 kW
3.7	3.7 kW
5.5	5.5 kW
7.5	7.5 kW
11	11 kW
15	15 kW
18.5	18.5 kW
22	22 kW
26	26 kW

③ **Maximum rotation speed**
 Indicates the hundreds place and higher order digits.

④ **Specification code**
 Indicates a specification code (01 to 99).

⑤ **Encoder**

Symbol	Type
None	Type 1
T	Type 2

⑥ **Specifications (Note)**

Symbol	Specifications
None	Standard
A	With leg
C	Shaft with key
J	Oil seal
K	Coil changeover
S	Hollow shaft
X	Reversed cooling air

(Note) If more than one option is included, the symbols are in alphabetical order.

<SJ-V/VL Series> SJ- ① ② ③ ④ - ⑤ ⑥ T

① **Series**

Symbol	Series
V	Medium inertia Series
VL	Low inertia Series

② **Coil changeover**

Symbol	Coil changeover
None	Unavailable
K	Available

③ **Shaft configuration**

Symbol	Shaft configuration
None	Standard

④ **Short-time rated output (Standard specification)**

Symbol	Short-time rated output
0.75	0.75 kW
1.5	1.5 kW
2.2	2.2 kW
3.7	3.7 kW
5.5	5.5 kW
7.5	7.5 kW
11	11 kW
15	15 kW
18.5	18.5 kW
22	22 kW
26	26 kW
37	37 kW
45	45 kW
55	55 kW

⑤ **Specification code**
 The SJ-V/VL Series is indicated with a specification code (01 to 99).

⑥ **Special specifications**

Symbol	Special specifications
None	Standard
Z	High-speed bearing
FZ	High-speed bearing front-lock

(Note) This explains the model name system of a spindle motor, and all combinations of motor types listed above do not exist.

For the motors not shown in the following tables, contact your Mitsubishi Electric dealer.

■200V Flange type

Flange type	Short-time rating Max. rotation speed	Power (kW)													
		0.75kW	1.5kW	2.2kW	3.7kW	5.5kW	7.5kW	11kW	15kW	18.5kW	22kW	26kW	37kW	45kW	55kW
Normal specifications	8,000 [r/min]								D15/80-01	D18.5/80-01	D22/80-01	D26/80-01	V37-01ZT (6,000 [r/min])	V45-01ZT (6,000 [r/min])	V55-01ZT (4,500 [r/min])
	10,000 [r/min]			V2.2-01T	D3.7/100-01	D5.5/100-01	D7.5/100-01	D11/100-01	V22-06ZT						
	12,000 [r/min]				V3.7-02ZT (15,000 [r/min])	D5.5/120-01	D7.5/120-01								
Wide range constant output specifications	6,000 [r/min]					V11-01T	V11-09T V15-03T (9kW)	V18.5-03T	V22-05T	V22-09T (4,500 [r/min])	VK22-19ZT (Coil changeover)				
High-output specifications	10,000 [r/min]							DG11/100-03T							
	12,000 [r/min]				DG3.7/120-03T	DG5.5/120-04T	DG7.5/120-05T	DG11/120-03T	DG15/120-02T-K						
Compact & lightweight specifications	10,000 [r/min]					DJ5.5/100-01	DJ7.5/100-01	DJ11/100-01	DJ15/80-01 (8,000 [r/min])						
	12,000 [r/min]					DJ5.5/120-01	DJ7.5/120-01								
Low-inertia specifications	15,000 [r/min]	DL0.75/100-01 (10,000 [r/min])	DL1.5/100-01 (10,000 [r/min])	VL2.2-02ZT	VL11-02FZT	DL5.5/150-01T	DL7.5/150-01T								
	20,000 [r/min]				VL11-05FZT-S01 (3kW)	DL5.5/200-01T									
	24,000 [r/min]				DL3.7/240-01T	DL5.5/240-05T									
High-torque specifications	8,000 [r/min]						DN7.5/80-01	DN11/80-01	DN15/80-01	DN18.5/80-01					

■200V Flange type (hollow shaft)

Flange type (hollow shaft)	Short-time rating Max. rotation speed	Power (kW)													
		0.75kW	1.5kW	3.7kW	5.5kW	7.5kW	11kW	15kW	18.5kW	22kW	26kW				
Normal specifications	8,000 [r/min]											D15/80-01	D18.5/80-01	D22/80-01	D26/80-01
	10,000 [r/min]			D3.7/100-01	D5.5/100-01	D7.5/100-01	D11/100-01								
High-output specifications	10,000 [r/min]							DG11/100-03T							
	12,000 [r/min]			DG3.7/120-03T	DG5.5/120-04T	DG7.5/120-05T	DG11/120-03T								
Low-inertia specifications	15,000 [r/min]	DL0.75/100-01 (10,000 [r/min])	DL1.5/100-01 (10,000 [r/min])		DL5.5/150-01T	DL7.5/150-01T									
	20,000 [r/min]				DL5.5/200-01T										
	24,000 [r/min]			DL3.7/240-01T	DL5.5/240-05T										
High-torque specifications	8,000 [r/min]						DN7.5/80-01	DN11/80-01	DN15/80-01	DN18.5/80-01					

■200V Type with leg

Type with leg	Short-time rating Max. rotation speed	Power (kW)													
		0.75kW	1.5kW	2.2kW	3.7kW	5.5kW	7.5kW	11kW	15kW	18.5kW	22kW	26kW	37kW	45kW	55kW
Normal specifications	8,000 [r/min]								V15-09ZT	V18.5-01ZT	V22-01ZT	V26-01ZT	V37-01ZT (6,000 [r/min])	V45-01ZT (6,000 [r/min])	V55-01ZT (4,500 [r/min])
	10,000 [r/min]			V2.2-01T	D3.7/100-01	D5.5/100-01	D7.5/100-01	D11/100-01	V22-06ZT						
	12,000 [r/min]				V3.7-02ZT (15,000 [r/min])	D5.5/120-01	D7.5/120-01								
Wide range constant output specifications	6,000 [r/min]					V11-01T	V11-09T V15-03T (9kW)	V18.5-03T	V22-05T	V22-09T (4,500 [r/min])	VK22-19ZT (Coil changeover)				
High-torque specifications	8,000 [r/min]						DN7.5/80-01	DN11/80-01	DN15/80-01	DN18.5/80-01					

■200V Built-in spindle motor

<SJ-BG Series> SJ-BG ① ② / ③ - ④ ⑤ ⑥ ⑦

① **Stator dimensions**

Symbol	Stator dimensions
90	ø90mm
110	ø110mm
120	ø120mm
135	ø135mm
150	ø150mm
160	ø160mm
180	ø180mm
240	ø240mm
300	ø300mm

② **Core width (A to Z)**

③ **Maximum rotation speed**
Indicates the hundreds place and higher order digits.

④ **Specification code (01 to 99)**

⑤ **Power line**

Symbol	Length of lead
1	500mm
2	1000mm
3	1500mm
4	2000mm

⑥ **Coil changeover**

Symbol	Coil changeover
None	Unavailable
K	Available (人-Δ)
W	Available (人-人)

⑦ **Option**

Symbol	Stator dimensions
None	Standard (varnish)
J	Varnish with sleeve (cooling jacket)
S	With sleeve (cooling jacket), mold without metal ring
F	With sleeve (cooling jacket), mold with metal ring
L	Without sleeve (cooling jacket), mold without metal ring
G	Without sleeve (cooling jacket), mold with metal ring
R	Rotor inner diameter expanded specifications

<SJ-B Series> SJ- ① B ② ③ ④ ⑤ ⑥

① **Voltage**

Symbol	Voltage
2	200V
4	400V

* 400V is available by special order.

② **Number of poles**

Symbol	Number of poles
2	2 poles
4	4 poles
6	6 poles

③ **Motor size**

Symbol	Stator dimensions
0	ø110
1	ø128
2	ø160
3	ø180
4	ø210
5	ø230
6	ø255
7	ø300
9	ø370
A	ø90
B	ø115

Stator outline (frame No.) is indicated with 0 to 9, A, B.

④ **Specification code**
Specification code (01 to 99)

⑤ **Overheat protection sensor**

Symbol	Overheat protection sensor
T	Thermistor

⑥ **Coil changeover**

Symbol	Coil changeover
None	Unavailable
D	Available (Δ-2/Δ)
K	Available (人-Δ)

<SJ-PMB Series> SJ- ① PMB ② ③ ④ - ⑤

① **Voltage**

Symbol	Voltage
None	200V
4	400V

* 400V is available by special order.

② **Continuous rated torque**
Indicates with 3 digits.
For 1000 [N·m] or more (for 9999 [N·m] or less), the upper digit is indicated by alphabetic character and the others are indicated by the carried number.
Example) 020 : 20 [N·m] A55 : 1550 [N·m]

③ **Base rotation speed**
Indicates the thousands and the hundreds places (the ten places are rounded off.)
Example) 03 : 250 to 349 [r/min] 15 : 1450 to 1549 [r/min]

④ **Overheat protection sensor**

Symbol	Overheat protection sensor
T	Thermistor

⑤ **Design management No.**
Indicates with 2 digits number or alphabetic characters Example) 00, A1

(Note) This explains the model name system of a spindle motor, and all combinations of motor types listed above do not exist.

For the motors not shown in the following tables, contact your Mitsubishi Electric dealer.

For the encoder of the built-in spindle motor, refer to p.163 to 165 "Spindle side PLG serial output encoder (TS5690, MU1606 Series)".

200V SJ-BG Series

Motor type	Motor type	Stator outer diameter [mm]	Rotor inner diameter [mm]	Total length of motor [mm]	Coil	Continuous rated output [kW]	Short time rated output [kW]		
Normal specifications	SJ-BG090A/300-01□(R)	89.5	33(35)	81	-	0.75	1.1		
	SJ-BG090B/300-03□		33	100	-	1.2	1.5		
	SJ-BG090D/300-03□		153	-	5.5	9			
	SJ-BG110F/240-01□	109.5	42	240	-	3	5.5		
	SJ-BG120A/200-01□(R)	119.5	41(52)	135	Low-speed coil	1.5	3.7		
	SJ-BG120C/200-01□(R)			195	High-speed coil	1.5	5.5		
	SJ-BG135D/200-01□	134.5	60	219	Low-speed coil	11	15		
	SJ-BG150D/150-01□	149.5	55	170	High-speed coil	18.5	26		
	SJ-BG160B/150-01□(R)			153	-	3.7	5.5		
	SJ-BG160D/150-01□(R)	159.5	60(70)	188	-	3.7	7.5		
	SJ-BG160D/150-02□(R)			188	-	3.7	5.5		
	SJ-BG180B/150-01□	179.5	75	212	Low-speed coil	11	18.5		
	SJ-BG180D/150-01□			277	High-speed coil	18.5	30		
	SJ-BG180F/150-01□			322	Low-speed coil	15	22		
	SJ-BG180H/150-01□			377	High-speed coil	22	30		
	SJ-BG240H/100-01□			239.5	101	460	Low-speed coil	15	26
	SJ-BG300L/080-01□			299.5	130	515	High-speed coil	26	37
	High-speed specifications	SJ-BG160D/200-03□	159.5	70	197	Low-speed coil	7.5	15	
		SJ-BG180F/200-01□	179.5	75	322	High-speed coil	15	22	
		SJ-BG240H/130-01□	239.5	101	460	Low-speed coil	15	22	
SJ-BG240H/130-01□		460			High-speed coil	18.5	30		

(Note) A value in brackets is for the rotor inner diameter of the motor type which has (R) in the end of the type name.

200V SJ-B Series

Motor type	Motor type	Stator outer diameter [mm]	Rotor inner diameter [mm]	Total length of motor [mm]	Coil	Continuous rated output [kW]	Short time rated output [kW]		
Normal specifications	SJ-2B4002T	109.5	42	120	-	0.4	0.75		
	SJ-2B4004T			160	-	0.75	1.5		
	SJ-2B4003T			160	-	1.5	2.2		
	SJ-2B4501TK	229.5	95	320	Low-speed coil	7.5	11		
	SJ-2B4502TK			380	High-speed coil	7.5	11		
	SJ-2B4503TK			445	Low-speed coil	7.5	11		
	SJ-2B4602TK			440	High-speed coil	11	15		
	SJ-2B4601TK			440	Low-speed coil	15	22		
	SJ-2B6611TK			380	High-speed coil	18.5	22		
	Normal specifications	SJ-2B6602TK	254.5	110	320	Low-speed coil	22	26	
		SJ-2B6605TK			380	High-speed coil	22	26	
		SJ-2B6603TK			320	Low-speed coil	7.5	11	
		SJ-2B6705TK			380	High-speed coil	7.5	11	
		SJ-2B6711TK			440	Low-speed coil	11	15	
		SJ-2B6706TK			440	High-speed coil	11	15	
		Normal specifications	SJ-2B6720TK	299.5	130	440	Low-speed coil	15	22
			SJ-2B6704TK			440	High-speed coil	15	22
			SJ-2B6709TK			445	Low-speed coil	15	22
			SJ-2B6721TK			445	High-speed coil	15	22
			SJ-2B6905TK			400	Low-speed coil	15	22
			SJ-2B6908TK			400	High-speed coil	15	22
	Normal specifications		SJ-2B6906TK	369.5	165	405	Low-speed coil	7.5	11
			SJ-2B6914TK			405	High-speed coil	7.5	11
			SJ-2B6706TK			405	Low-speed coil	11	15
			SJ-2B6706TK			405	High-speed coil	11	15
			SJ-2B6720TK			300	Low-speed coil	15	22
			SJ-2B6704TK			300	High-speed coil	15	22
	Normal specifications	SJ-2B6709TK	299.5	130	470	Low-speed coil	15	22	
		SJ-2B6709TK			470	High-speed coil	15	22	
		SJ-2B6709TK			450	Low-speed coil	22	30	
SJ-2B6709TK		450			High-speed coil	22	30		
SJ-2B6721TK		390			Low-speed coil	18.5	22		
SJ-2B6721TK		390			High-speed coil	22	30		
Normal specifications	SJ-2B6905TK	369.5	165	465	Low-speed coil	22	26		
	SJ-2B6908TK			465	High-speed coil	22	26		
	SJ-2B6906TK			545	Low-speed coil	15	22		
	SJ-2B6906TK			545	High-speed coil	15	22		
	SJ-2B6906TK			555	Low-speed coil	22	30		
	SJ-2B6906TK			555	High-speed coil	30	37		
Normal specifications	SJ-2B6914TK	369.5	165	520	Low-speed coil	25	30		
	SJ-2B6914TK			520	High-speed coil	25	30		

200V SJ-PMB Series

Motor type	Motor type	Stator outer diameter [mm]	Rotor inner diameter [mm]	Total length of motor [mm]	Coil	Continuous rated output [kW]	Short time rated output [kW]
IPM motor	SJ-PMB02215T-02	139.5	60	150	-	3.5	5.5
	SJ-PMB04412T-B0	179.5	70.6	225	Low-speed coil	5.5	7.5
	SJ-PMB04412T-B0	179.5	70.6	225	High-speed coil	5.5	7.5
	SJ-PMB14007T-01	254.5	95	250	Low-speed coil	11	15
SJ-PMB14007T-01	254.5	95	250	High-speed coil	11	15	

200V Tool spindle motor

<HG Series> HG ① ② - ③ - ④

① Rated output · Maximum rotation speed

Symbol	Rated output	Max. rotation speed	Flange size (mm)
46	0.4 kW	6000 r/min	60 SQ.
56	0.5 kW	6000 r/min	60 SQ.
96	0.9 kW	6000 r/min	80 SQ.
75	0.75 kW	4000 r/min	90 SQ.
105	1.0 kW	4000 r/min	90 SQ.
54	0.5 kW	3000 r/min	130 SQ.
104	1.0 kW	3000 r/min	130 SQ.
154	1.5 kW	3000 r/min	130 SQ.
224	2.2 kW	3000 r/min	130 SQ.
204	2.0 kW	3000 r/min	176 SQ.
354	3.5 kW	3000 r/min	176 SQ.
453	4.5 kW	3000 r/min	176 SQ.
703	7.0 kW	3000 r/min	176 SQ.
903	9.0 kW	3000 r/min	204 SQ.

② Shaft end structure

Symbol	Shaft end structure
S	Straight
K	With keyway (with key)

(Note) "K: With keyway (with key)" is only available for HG46/56/96.

③ Power connector

Symbol	Connector
None	Normal
S105010	Compact (horizontal direction)

(Note) S105010 can only be used with HG75/105.

④ Encoder

Symbol	Type	Resolution
D47	OSA24RS-120	1,048,576 p/rev
D48	OSA24RS	1,048,576 p/rev

(Note 1) Encoder D51 and D74 can not be used with the tool spindle motor.
(Note 2) Encoder D47 can only be used with HG46/56/96.

<HG-JR Series> HG-JR ① E1 ② W9C - ③

① Rated output · Maximum rotation speed

Symbol	Rated output	Max. rotation speed	Flange size (mm)
73	0.75 kW	8000 r/min	90 SQ.
153	1.5 kW	8000 r/min	90 SQ.

② Shaft end structure

Symbol	Shaft end structure
None	Straight
K	With keyway (without key)

③ Power connector

Symbol	Connector
S105003	Normal (vertical direction)
S105010	Compact (horizontal direction)

400V HG-H servo motor

<HG-H Series>

HG-H ① ② ③ - ④ - ⑤

① Rated output · Maximum rotation speed

Symbol	Rated output	Max. rotation speed	Flange size (mm)
75	0.75 kW	5000 r/min	90 SQ.
105	1.0 kW	5000 r/min	90 SQ.
54	0.5 kW	4000 r/min	130 SQ.
104	1.0 kW	4000 r/min	130 SQ.
154	1.5 kW	4000 r/min	130 SQ.
224	2.2 kW	4000 r/min	130 SQ.
204	2.0 kW	4000 r/min	176 SQ.
354	3.5 kW	4000 r/min	176 SQ.
453	4.5 kW	3500 r/min	176 SQ.
703	7.0 kW	3000 r/min	176 SQ.
903	9.0 kW	3000 r/min	204 SQ.
1502	15.0kW	2500 r/min	250 SQ.

② Magnetic brake

Symbol	Magnetic brake
None	None
B	With magnetic brake

(Note) Magnetic brakes cannot be used for HG-H1502.

③ Shaft end structure

Symbol	Shaft end structure
S	Straight
T	Taper

(Note) "Taper" is available for the motor whose flange size is 90 SQ. mm or 130 SQ. mm.

④ Power connector

Symbol	Connector
None	Normal
S105010	Compact (horizontal direction)

(Note) S105010 can only be used with HG-H75/105.

⑤ Encoder

Symbol	Type	Detection method	Resolution
D48	OSA24RS	Absolute position	1,048,576 p/rev
D51	OSA405S5AS		4,194,304 p/rev
D74	OSA676S5AS		67,108,864 p/rev

<HQ-H Series>

HQ-H ① ② S - ③

① Rated output · Maximum rotation speed

Symbol	Rated output	Max. rotation speed	Flange size (mm)
903	9.0kW	3000 r/min	220 SQ.
1103	11.0kW	3000 r/min	220 SQ.

② Magnetic brake

Symbol	Magnetic brake
None	None
B	With magnetic brake

③ Encoder

Symbol	Type	Detection method	Resolution
D48	OSA24RS	Absolute position	1,048,576 p/rev
D51	OSA405S5AS		4,194,304 p/rev
D74	OSA676S5AS		67,108,864 p/rev

400V Linear servo motor

<LM-F Series>

Primary side [coil side]

LM-FP ① ② - ③ M-1WW0

① Width		② Length		③ Rated thrust	
Symbol	Width (nominal)	Symbol	Length (nominal)	Symbol	Rated thrust
5	240 mm	H	1010 mm	60	6000 N

Secondary side [magnet side]

LM-FS ① 0- ② -1WW0

① Width		② Length	
Symbol	Width (nominal)	Symbol	Length (nominal)
5	240 mm	480	480 mm
		576	576 mm

400V Spindle motor with frame

<SJ-4-V Series>

SJ-4- ① ② ③ ④ - ⑤ ⑥ T

① Motor Series

Symbol	Motor Series
V	Medium inertia Series

② Coil changeover

Symbol	Coil changeover
None	Unavailable

③ Shaft configuration

Symbol	Shaft configuration
None	Standard

④ Short-time rated output (Standard specification)

Symbol	Short-time rated output
2.2	2.2kW
3.7	3.7kW
5.5	5.5kW
7.5	7.5kW
11	11kW
15	15kW
18.5	18.5kW
22	22kW
26	26kW
37	37kW
45	45kW
55	55kW

⑤ Specification code

The SJ-4-V Series is indicated with a specification code (01 to 99).

⑥ Special specifications

Symbol	Special specifications
None	None
Z	High-speed bearing

(Note) This explains the model name system of a spindle motor, and all combinations of motor types listed above do not exist.

400V SJ-4-V Series

Flange type With leg	Short-time rating Max. rotation speed	2.2kW	3.7kW	5.5kW	7.5kW	9kW	11kW	15kW	18.5kW	22kW	26kW	37kW	45kW	55kW
		Normal specifications	6,000 [r/min]					V11-18T	V18.5-14T		V22-15T		V37-04ZT	V45-02T (4,500 [r/min])
	8,000 [r/min]			V5.5-07T	V7.5-12T			V22-18ZT						
	10,000 [r/min]	V2.2-03T	V3.7-03T							V26-08ZT				
	12,000 [r/min]				V7.5-13ZT									
Wide range constant output specifications	6,000 [r/min]					V15-20T		V22-16T						

400V Built-in spindle motor

<SJ-4BG Series>

SJ-4BG ① ② / ③ - ④ ⑤ ⑥ ⑦

① Stator dimensions

Symbol	Stator dimensions
160	φ160mm
180	φ180mm
300	φ300mm

② Core width (A to Z)

③ Maximum rotation speed
Indicates the hundreds place and higher order digits.

④ Specification code (01 to 99)

⑤ Power line

Symbol	Length of lead
1	500mm
2	1000mm
3	1500mm
4	2000mm

⑥ Coil changeover

Symbol	Coil changeover
None	Unavailable
K	Available (人-△)
W	Available (人-人)

⑦ Option

Symbol	Stator dimensions
None	Standard (varnish)
J	Varnish with sleeve (cooling jacket)
S	With sleeve (cooling jacket), mold without metal ring
F	With sleeve (cooling jacket), mold with metal ring
L	Without sleeve (cooling jacket), mold without metal ring
G	Without sleeve (cooling jacket), mold with metal ring
R	Rotor inner diameter expanded specifications

<SJ-4BGS Series>

SJ-4BGS ① ② / ③ - ④ ⑤ ⑥ ⑦

① Stator dimensions

Symbol	Stator dimensions
160	φ160mm
210	φ210mm
240	φ240mm

② Core width (A to Z)

③ Maximum rotation speed
Indicates the hundreds place and higher order digits.

④ Specification code (01 to 99)

⑤ Power line

Symbol	Length of lead
1	500mm
2	1000mm
3	1500mm
4	2000mm

⑥ Coil changeover

Symbol	Coil changeover
None	Unavailable
K	Available (人-△)
W	Available (人-人)

⑦ Coil changeover

Symbol	Option
None	Varnish
L	Without sleeve (cooling jacket), mold without metal ring
G	Without sleeve (cooling jacket), mold with metal ring
R	With rotor sleeve

(Note) This explains the model name system of a spindle motor, and all combinations of motor types listed above do not exist.

■400V SJ-4BG Series

Motor type	Motor type	Stator outer diameter [mm]	Rotor inner diameter [mm]	Total length of motor [mm]	Coil	Continuous rated output [kW]	Short time rated output [kW]
Normal specifications	SJ-4BG160D/150-01	159.5	60	188	—	3.7	7.5
	SJ-4BG180F/150-01	179.5	75	322	Low-speed coil	7.5	11
					High-speed coil	7.5	11
	SJ-4BG300C/080-02	299.5	130	295	Low-speed coil	11	15
High-speed coil					15	22	

■400V SJ-4BGS Series

Motor type	Motor type	Stator outer diameter [mm]	Rotor inner diameter [mm]	Total length of motor [mm]	Coil	Continuous rated output [kW]	Short time rated output [kW]
SPM motor	SJ-4BGS160B/300-01	159.5	80.9	194	—	65	70
	SJ-4BGS210B/120-01	209.5	84	180	Low-speed coil	22	24
					High-speed coil	22	24
	SJ-4BGS240B/120-01	239.5	100	220	Low-speed coil	27	37
High-speed coil					27	37	

■400V Tool spindle motor

<HG-JR Series>

HG-JR ① E1 ② W9C- ③

① Rated output · Maximum rotation speed

Symbol	Rated output	Max. rotation speed	Flange size (mm)
734	0.75 kW	8000 r/min	90 SQ.
1534	1.5 kW	8000 r/min	90 SQ.

② Shaft end structure

Symbol	Shaft end structure
None	Straight
K	With keyway (without key)

③ Power connector

Symbol	Connector
S105003	Normal (vertical direction)
S105010	Compact (horizontal direction)

SERVO MOTOR 200V

■HG Series

Motor type	HG46	HG56	HG96	
Compatible drive unit	1-axis type MDS-E-V1-	20	20	20
	2-axis type MDS-E-V2-	20	20	20
	3-axis type MDS-E-V3-	20	20	20
	Multi-hybrid type MDS-EM-SPV3-	—	—	10040, 16040, 16040S
	Regenerative resistor type MDS-EJ-V1- MDS-EJ-V2-	10	15	30
Output				
Rated output [kW]	0.2	0.4	0.75	
Max. rotation speed [r/min]	6000			
Motor inertia [$\times 10^{-4}$ kg·m ²]	0.234	0.379	1.27	
Motor inertia with a brake [$\times 10^{-4}$ kg·m ²]	0.261	0.407	1.37	
Degree of protection (The shaft-through portion is excluded.)	IP67			
Outline dimension drawing (Without a brake, Straight shaft) [mm]				
Flange fitting diameter [mm]	ø50	ø50	ø70	
Shaft diameter [mm]	ø14	ø14	ø19	
Mass (with a brake) [kg]	1.2(1.6)	1.6(2.0)	2.9(3.7)	
Absolute position encoder compatible drive unit	1,048,576 [p/rev] (D47)	E, EJ	E, EJ	
	E, EJ	E, EJ	E, EM, EJ	

Motor type	HG75	HG105	HG54	HG104	HG154	
Compatible drive unit	1-axis type MDS-E-V1-	20	20	40	40	80
	2-axis type MDS-E-V2-	20	20	40	40	80
	3-axis type MDS-E-V3-	40	40	80	80	160
	Multi-hybrid type MDS-EM-SPV3-	20	20	40	40	80
	Regenerative resistor type MDS-EJ-V1- MDS-EJ-V2-	40	40	80	80	40
Output						
Rated output [kW]	0.75	1.0	0.5	1.0	1.5	
Max. rotation speed [r/min]	5000					
Motor inertia [$\times 10^{-4}$ kg·m ²]	2.62	5.12	6.13	11.9	17.8	
Motor inertia with a brake [$\times 10^{-4}$ kg·m ²]	2.70	5.20	8.26	14.0	20.0	
Degree of protection (The shaft-through portion is excluded.)	IP67	IP67	IP67	IP67	IP67	
Outline dimension drawing (Without a brake, Straight shaft, D48 encoder) [mm]						
(Note) The total length will be 3.5mm longer when using a D51 or D74 encoder.						
Flange fitting diameter [mm]	ø80	ø80	ø110	ø110	ø110	
Shaft diameter [mm]	ø14	ø14	ø24	ø24	ø24	
Mass (with a brake) [kg]	2.6(3.6)	4.4(5.3)	4.8(6.7)	6.5(8.5)	8.3(11.0)	
Absolute position encoder compatible drive unit	67,108,864 [p/rev] (D74)	E	E	E	E	
	4,194,304 [p/rev] (D51)	E	E	E	E	
	1,048,576 [p/rev] (D48)	E, EJ	E, EJ	E, EJ	E, EJ	
		E, EJ	E, EJ	E, EJ	E	

(Note 1) Only the combination designated in this manual can be used for the motor and drive unit. Always use the designated combination.
 (Note 2) Stall torque is the maximum torque that can be output continuously when the motor rotation is stopped.

■HG Series

Motor type		HG224	HG204		HG354		
Compatible drive unit	1-axis type MDS-E-V1-	80	-	80	-	-	160
	2-axis type MDS-E-V2-	80	-	80	-	-	160
	3-axis type MDS-E-V3-	160	-	160	-	-	160W
	Multi-hybrid type MDS-EM-SPV3-	10080, 16080, 20080, 200120, 320120	-	10080, 16080, 20080, 200120, 320120	-	-	200120, 320120
	Regenerative resistor type	MDS-EJ-V1- MDS-EJ-V2-	80	80	-	100	-
Output							
Rated output	[kW]	2.2	2.0		3.5		
Max. rotation speed	[r/min]	4000	4000		3500		
Motor inertia	[$\times 10^{-4} \text{kg} \cdot \text{m}^2$]	23.7	38.3		75.0		
Motor inertia with a brake	[$\times 10^{-4} \text{kg} \cdot \text{m}^2$]	25.9	47.9		84.7		
Degree of protection (The shaft-through portion is excluded.)		IP67	IP67		IP67		
Outline dimension drawing (Without a brake, Straight shaft, D48 encoder)	[mm]	130 SQ. 184.5	176 SQ. 143.5		176 SQ. 183.5		
(Note) The total length will be 3.5mm longer when using a D51 or D74 encoder.							
Flange fitting diameter	[mm]	$\phi 110$	$\phi 114.3$		$\phi 114.3$		
Shaft diameter	[mm]	$\phi 24$	$\phi 35$		$\phi 35$		
Mass (with a brake)	[kg]	10.0(12.0)	12.0(18.0)		19.0(25.0)		
Absolute position encoder compatible drive unit		67,108,864 [p/rev] (D74) 4,194,304 [p/rev] (D51) 1,048,576 [p/rev] (D48)	E EM, EJ	- EJ	E EM	- EJ	EM E

Motor type		HG123	HG223	HG303	HG453		
Compatible drive unit	1-axis type MDS-E-V1-	20	40	80	-	160	
	2-axis type MDS-E-V2-	20	40	80	-	160	
	3-axis type MDS-E-V3-	40	80	160	-	160W	
	Multi-hybrid type MDS-EM-SPV3-	10040, 16040, 16040S	10040, 16040, 16040S, 10080, 16080, 20080	10080, 16080, 20080, 200120, 320120	-	-	
	Regenerative resistor type	MDS-EJ-V1- MDS-EJ-V2-	40	40	80	-	-
Output							
Rated output	[kW]	1.2	2.2	3.0	4.5		
Max. rotation speed	[r/min]	3000	3000	3000	3500		
Motor inertia	[$\times 10^{-4} \text{kg} \cdot \text{m}^2$]	11.9	23.7	75.0	112.0		
Motor inertia with a brake	[$\times 10^{-4} \text{kg} \cdot \text{m}^2$]	14.0	25.9	84.7	122.0		
Degree of protection (The shaft-through portion is excluded.)		IP67	IP67	IP67	IP67		
Outline dimension drawing (Without a brake, Straight shaft, D48 encoder)	[mm]	130 SQ. 140.5	130 SQ. 184.5	176 SQ. 183.5	176 SQ. 223.5		
(Note) The total length will be 3.5mm longer when using a D51 or D74 encoder.							
Flange fitting diameter	[mm]	$\phi 110$	$\phi 110$	$\phi 114.3$	$\phi 114.3$		
Shaft diameter	[mm]	$\phi 24$	$\phi 24$	$\phi 35$	$\phi 35$		
Mass (with a brake)	[kg]	6.5(8.5)	10.0(12.0)	19.0(25.0)	25.0(31.0)		
Absolute position encoder compatible drive unit		67,108,864 [p/rev] (D74) 4,194,304 [p/rev] (D51) 1,048,576 [p/rev] (D48)	E EM, EJ	E EM, EJ	- EM	E	

(Note 1) Only the combination designated in this manual can be used for the motor and drive unit. Always use the designated combination.
(Note 2) Stall torque is the maximum torque that can be output continuously when the motor rotation is stopped.

■HG Series

Motor type		HG603	HG702	HG703	HG903	HG1103
Compatible drive unit	1-axis type MDS-E-V1-	160	160	160W	320	320W
	2-axis type MDS-E-V2-	160	160	160W	-	-
	3-axis type MDS-E-V3-	-	-	-	-	-
	Multi-hybrid type MDS-EM-SPV3-	-	200120, 320120	-	-	-
	Regenerative resistor type	MDS-EJ-V1- MDS-EJ-V2-	-	-	-	-
Output						
Rated output	[kW]	6.0	7.0	7.0	9.0	11.0
Max. rotation speed	[r/min]	3000	2000	3000	3000	3000
Motor inertia	[$\times 10^{-4} \text{kg} \cdot \text{m}^2$]	154.0	154.0	154.0	196.0	315.0
Motor inertia with a brake	[$\times 10^{-4} \text{kg} \cdot \text{m}^2$]	164.0	164.0	164.0	206.0	336.0
Degree of protection (The shaft-through portion is excluded.)		IP67	IP67	IP67	IP67	IP67
Outline dimension drawing (Without a brake, Straight shaft, D48 encoder)	[mm]	176 SQ. 263.5	176 SQ. 263.5	176 SQ. 263.5	204 SQ. 330	220 SQ. 438
(Note) The total length will be 3.5mm longer when using a D51 or D74 encoder.						
Flange fitting diameter	[mm]	$\phi 114.3$	$\phi 114.3$	$\phi 114.3$	$\phi 180$	$\phi 200$
Shaft diameter	[mm]	$\phi 35$	$\phi 35$	$\phi 35$	$\phi 42$	$\phi 55$
Mass (with a brake)	[kg]	32.0(38.0)	32.0(38.0)	32.0(38.0)	43.0(49.0)	86.0(97.0)
Absolute position encoder compatible drive unit		67,108,864 [p/rev] (D74) 4,194,304 [p/rev] (D51) 1,048,576 [p/rev] (D48)	E E, EM	E	E	E

Motor type		HG142	HG302
Compatible drive unit	1-axis type MDS-E-V1-	20	40
	2-axis type MDS-E-V2-	20	40
	3-axis type MDS-E-V3-	40	80
	Multi-hybrid type MDS-EM-SPV3-	10040, 16040, 16040S	10040, 16040, 16040S, 10080, 16080, 20080
	Regenerative resistor type	MDS-EJ-V1- MDS-EJ-V2-	40
Output			
Rated output	[kW]	1.4	3.0
Max. rotation speed	[r/min]	2000	2000
Motor inertia	[$\times 10^{-4} \text{kg} \cdot \text{m}^2$]	17.8	75.0
Motor inertia with a brake	[$\times 10^{-4} \text{kg} \cdot \text{m}^2$]	20.0	84.7
Degree of protection (The shaft-through portion is excluded.)		IP67	IP67
Outline dimension drawing (Without a brake, Straight shaft, D48 encoder)	[mm]	130 SQ. 162.5	176 SQ. 183.5
(Note) The total length will be 3.5mm longer when using a D51 or D74 encoder.			
Flange fitting diameter	[mm]	$\phi 110$	$\phi 114.3$
Shaft diameter	[mm]	$\phi 24$	$\phi 35$
Mass (with a brake)	[kg]	8.3(11.0)	19.0(25.0)
Absolute position encoder compatible drive unit		67,108,864 [p/rev] (D74) 4,194,304 [p/rev] (D51) 1,048,576 [p/rev] (D48)	E E, EM, EJ

(Note 1) Only the combination designated in this manual can be used for the motor and drive unit. Always use the designated combination.
(Note 2) Stall torque is the maximum torque that can be output continuously when the motor rotation is stopped.

DIRECT-DRIVE MOTOR 200V

TM-RB Series

Motor type	Primary side type		TM-RBP012C20	TM-RBP036E20	TM-RBP048G20	TM-RBP105G10
	Secondary side type		TM-RBS012C20	TM-RBS036E20	TM-RBS048G20	TM-RBS105G10
Compatible drive unit	1-axis type	MDS-E-V1-	40	80	80	160
	2-axis type	MDS-E-V2-	40	80	80	160
	Regenerative resistor type	MDS-EJ-V1-	40	80	80	100
Output	Rated torque (liquid-cooling)		[N·m]			
	Max. torque		[N·m]			
Rated output			252	754	1005	1100
Max. rotation speed			500	500	500	250
Motor inertia			22	127	280	395
Degree of protection			IP00	IP00	IP00	IP00
Outline dimension drawing			[mm]			
			[mm]			
Mass [kg]	Primary side (coil)		3.9	7.1	10	13
	Secondary side (magnet)		1.7	3.7	5	7

Motor type	Primary side type		TM-RBP105G20	TM-RBP150G20	TM-RBP340J20	TM-RBP500J20
	Secondary side type		TM-RBS105G20	TM-RBS150G20	TM-RBS340J20	TM-RBS500J20
Compatible drive unit	1-axis type	MDS-E-V1-	160	160	320	320W
	2-axis type	MDS-E-V2-	160	160	-	-
	Regenerative resistor type	MDS-EJ-V1-	-	-	-	-
Output	Rated torque (liquid-cooling)		[N·m]			
	Max. torque		[N·m]			
Rated output			2199	3141	7120	10471
Max. rotation speed			500	500	400	400
Motor inertia			395	510	2778	3538
Degree of protection			IP00	IP00	IP00	IP00
Outline dimension drawing			[mm]			
			[mm]			
Mass [kg]	Primary side (coil)		13	16	33	41
	Secondary side (magnet)		7	9	20	26

(Note 1) The encoder should be procured by the user.
 (Note 2) Only the combination designated in this manual can be used for the motor and drive unit. Always use the designated combination.

LINEAR SERVO MOTOR 200V

LM-F Series

Motor type	Primary side type		LM-FP2A-03M-1WW0	LM-FP2B-06M-1WW0	LM-FP2D-12M-1WW0	LM-FP2F-18M-1WW0
	Secondary side type		LM-FS20-□-1WW0	LM-FS20-□-1WW0	LM-FS20-□-1WW0	LM-FS20-□-1WW0
Compatible drive unit	1-axis type	MDS-E-V1-	40	40	80	160
	2-axis type	MDS-E-V2-	40	40	80	160
	3-axis type	MDS-E-V3-	40	40	80	-
	Regenerative resistor type	MDS-EJ-V1- MDS-EJ-V2-	40 40	40 40	80 -	- -
Thrust force	Continuous (natural-cooling)		[N]			
	Continuous (liquid-cooling)		[N]			
	Maximum		[N]			
Rated thrust			300	600	1200	1800
Maximum speed (Note 1)			2.0	2.0	2.0	2.0
Magnetic attraction force			2500	4500	9000	13500
Degree of protection			IP00	IP00	IP00	IP00
Outline dimension drawing			[mm]			
			[mm]			
Mass [kg]	Primary side (coil)		5	9	18	27
	Secondary side (magnet)		5.8(384mm) 7.1(480mm) 9.0(576mm)	5.8(384mm) 7.1(480mm) 9.0(576mm)	5.8(384mm) 7.1(480mm) 9.0(576mm)	5.8(384mm) 7.1(480mm) 9.0(576mm)
Motor type	Primary side type		LM-FP4B-12M-1WW0	LM-FP4D-24M-1WW0	LM-FP4F-36M-1WW0	LM-FP4H-48M-1WW0
	Secondary side type		LM-FS40-□-1WW0	LM-FS40-□-1WW0	LM-FS40-□-1WW0	LM-FS40-□-1WW0
Compatible drive unit	1-axis type	MDS-E-V1-	80	160	320	320W
	2-axis type	MDS-E-V2-	80	160	320W	320W
	3-axis type	MDS-E-V3-	80	-	-	-
	Regenerative resistor type	MDS-EJ-V1- MDS-EJ-V2-	80 -	- -	- -	- -
Thrust force	Continuous (natural-cooling)		[N]			
	Continuous (liquid-cooling)		[N]			
	Maximum		[N]			
Rated thrust			1200	2400	3600	4800
Maximum speed (Note 1)			2.0	2.0	2.0	2.0
Magnetic attraction force			9000	18000	27000	36000
Degree of protection			IP00	IP00	IP00	IP00
Outline dimension drawing			[mm]			
			[mm]			
Mass [kg]	Primary side (coil)		14	28	42	56
	Secondary side (magnet)		13.5(480mm) 16.0(576mm)	13.5(480mm) 16.0(576mm)	13.5(480mm) 16.0(576mm)	13.5(480mm) 16.0(576mm)

(Note 1) The maximum speed in actual use is either the linear scale's maximum speed or this specified value, whichever is smaller.
 (Note 2) Only the combination designated in this manual can be used for the motor and drive unit. Always use the designated combination.

LM-F Series (Dual-axis drive unit)

Motor type	Primary side type		LM-FP2A-03M-1WW0	LM-FP2B-06M-1WW0	LM-FP2D-12M-1WW0	LM-FP2F-18M-1WW0			
	Secondary side type		LM-FS20-□-1WW0	LM-FS20-□-1WW0	LM-FS20-□-1WW0	LM-FS20-□-1WW0			
Compatible drive unit	1-axis type	MDS-E-V1-	80	80	160 160W	320 320W			
	2-axis type	MDS-E-V2-	80	80	160 160W	-			
	Regenerative resistor type	MDS-EJ-V1-	80	80	-	-			
Thrust force	Continuous (natural-cooling)								
	Continuous (liquid-cooling)								
	Maximum								
Rated thrust	[N]	600	1200	2400	3600				
Maximum speed (Note 1)	[m/s]	2.0	2.0	2.0	2.0				
Magnetic attraction force (per motor)	[N]	2500	4500	9000	13500				
Degree of protection		IP00	IP00	IP00	IP00				
Outline dimension drawing	Primary side	Secondary side	Primary side	Secondary side	Primary side	Secondary side			
	[mm]								
Mass [kg]	Primary side (coil)	5x2		9x2		18x2		27x2	
	Secondary side (magnet)	5.8(384mm) 7.1(480mm) 9.0(576mm)		5.8(384mm) 7.1(480mm) 9.0(576mm)		5.8(384mm) 7.1(480mm) 9.0(576mm)		5.8(384mm) 7.1(480mm) 9.0(576mm)	

Motor type	Primary side type		LM-FP4B-12M-1WW0	LM-FP4D-24M-1WW0	
	Secondary side type		LM-FS40-□-1WW0	LM-FS40-□-1WW0	
Compatible drive unit	1-axis type	MDS-E-V1-	160 160W	320 320W	
	2-axis type	MDS-E-V2-	160 160W	-	
	Regenerative resistor type	MDS-EJ-V1-	-	-	
Thrust force	Continuous (natural-cooling)				
	Continuous (liquid-cooling)				
	Maximum				
Rated thrust	[N]	2400	4800		
Maximum speed (Note 1)	[m/s]	2.0	2.0		
Magnetic attraction force (per motor)	[N]	9000	18000		
Degree of protection		IP00	IP00		
Outline dimension drawing	Primary side	Secondary side	Primary side	Secondary side	
	[mm]				
Mass [kg]	Primary side (coil)	14x2		28x2	
	Secondary side (magnet)	13.5(480mm) 16.0(576mm)		13.5(480mm) 16.0(576mm)	

(Note 1) The maximum speed in actual use is either the linear scale's maximum speed or this specified value, whichever is smaller.
 (Note 2) Only the combination designated in this manual can be used for the motor and drive unit. Always use the designated combination.

SPINDLE MOTOR 200V

SJ-D Series (Normal specifications)

Motor type	SJ-D3.7/100-01		SJ-D5.5/100-01		SJ-D5.5/120-01		SJ-D5.5/120-02	
	1-axis type	MDS-E-SP-	80	80	80	-	160	200
Compatible drive unit	2-axis type	MDS-E-SP2-	80 16080(M)	80 16080(M)	80 16080(M)	-	16080(L)	-
	Multi-hybrid type	MDS-EM-SPV3-	-	10040, 10080, 16040S	10040, 10080, 16040S	10040, 10080	16040, 16080, 16040S	20080, 200120
	Regenerative resistor type	MDS-EJ-SP-	80	100	100	-	-	-
Output	Acceleration/Deceleration							
	%ED rating							
	Short-time rating							
	Continuous rating							
Standard output during acceleration/deceleration	[kW]	3.7	5.5	5.5	7.5	9.2	10.4	
Actual acceleration/deceleration output (Note 2)	[kW]	4.4	6.6	6.6	9	11.0	12.5	
Continuous base rotation speed	[r/min]	1500	1500	1500	2800	8000	12000	
Max. rotation speed in constant output range	[r/min]	6000	6000	6000	8000	12000	12000	
Maximum rotation speed	[r/min]	10000	10000	12000	12000	12000	12000	
Continuous rated torque	[N·m]	14.0	23.6	23.6	12.6	12.6	12.6	
Motor inertia	[kg·m ²]	0.0074	0.013	0.013	0.0074	0.0074	0.0074	
Degree of protection (The shaft-through portion is excluded.)		IP54	IP54	IP54	IP54	IP54	IP54	
Outline dimension drawing (flange type)	[mm]		[mm]		[mm]		[mm]	
	[mm]		[mm]		[mm]		[mm]	
Flange fitting diameter	[mm]	ø150	ø150	ø150	ø150	ø150	ø150	
Shaft diameter	[mm]	ø28	ø28	ø28	ø28	ø28	ø28	
Mass	[kg]	26	39	39	26	26	26	
With leg		Possible	Possible	Possible	Possible	Possible	Possible	

Motor type	SJ-D7.5/100-01		SJ-D7.5/120-01		SJ-D11/100-01		SJ-D15/80-01		SJ-D18.5/80-01	
	1-axis type	MDS-E-SP-	160	160	160	200	240	320	240	320
Compatible drive unit	2-axis type	MDS-E-SP2-	16080(L)	16080(L)	16080(L)	-	-	-	-	-
	Multi-hybrid type	MDS-EM-SPV3-	10040, 10080, 16040S	10040, 10080, 16040S	16040, 16080, 16040S	20080, 200120	-	320120	-	-
	Regenerative resistor type	MDS-EJ-SP-	120	120	160	-	-	-	-	-
Output	%ED rating									
	Short-time rating									
	Continuous rating									
Standard output during acceleration/deceleration	[kW]	7.5	7.5	11	18.5	18.5	25.0			
Actual acceleration/deceleration output (Note 2)	[kW]	9	9	13.2	22.2	22.2	30.0			
Continuous base rotation speed	[r/min]	1500	1500	1500	1500	1500	1500			
Max. rotation speed in constant output range	[r/min]	6000	6000	4500	6000	6000	6000			
Maximum rotation speed	[r/min]	10000	12000	10000	8000	8000	8000			
Continuous rated torque	[N·m]	35.0	35.0	47.7	70.0	70.0	95.5			
Motor inertia	[kg·m ²]	0.023	0.023	0.031	0.086	0.086	0.10			
Degree of protection (The shaft-through portion is excluded.)		IP54	IP54	IP54	IP54	IP54	IP54			
Outline dimension drawing (flange type)	[mm]		[mm]		[mm]		[mm]		[mm]	
	[mm]		[mm]		[mm]		[mm]		[mm]	
Flange fitting diameter	[mm]	ø180	ø180	ø180	ø230	ø230	ø230			
Shaft diameter	[mm]	ø32	ø32	ø48	ø48	ø48	ø48			
Mass	[kg]	53	53	64	93	93	103			
With leg		Possible	Possible	Possible	under development	under development	under development			

(Note 1) Only the combination designated in this manual can be used for the motor and drive unit. Always use the designated combination.
 (Note 2) Actual acceleration/deceleration output is 1.2-fold of "Standard output during acceleration/deceleration" or "Short time rated output".
 (Note 3) IP code classifies the degree of protection of the motor body. It does not apply to the other electronic parts such as the cooling fan and the encoder.

■SJ-D Series (Normal specifications)

Motor type		SJ-D22/80-01		SJ-D26/80-01	
Compatible drive unit	1-axis type	MDS-E-SP-	240	320	320
	2-axis type	MDS-E-SP2-	-	-	-
	Multi-hybrid type	MDS-EM-SPV3-	-	320120	320120
	Regenerative resistor type	MDS-EJ-SP-	-	-	-
Output	%ED rating				
	Short-time rating				
	Continuous rating				
Standard output during acceleration/deceleration [kW]			22.0	30.0	35.0
Actual acceleration/deceleration output (Note 2) [kW]			26.4	36.0	42.0
Continuous base rotation speed [r/min]			1500	1500	1500
Max. rotation speed in constant output range [r/min]			6000	6000	6000
Maximum rotation speed [r/min]			8000	8000	8000
Continuous rated torque [N·m]			118	140	140
Motor inertia [kg·m ²]			0.14	0.16	0.16
Degree of protection (The shaft-through portion is excluded.)			IP54	IP54	IP54
Outline dimension drawing (flange type)					
	[mm]		538.5	583.5	583.5
Flange fitting diameter [mm]			ø230	ø230	ø230
Shaft diameter [mm]			ø55	ø55	ø55
Mass [kg]			131	147	147
With leg			under development	under development	under development

■SJ-D Series (Hollow shaft specifications)

Motor type		SJ-D5.5/120-02T-S		
Compatible drive unit	1-axis type	MDS-E-SP-	160	200
	2-axis type	MDS-E-SP2-	16080(L)	-
	Multi-hybrid type	MDS-EM-SPV3-	10040, 10080	20080, 200120
	Regenerative resistor type	MDS-EJ-SP-	-	-
Output	Acceleration/Deceleration			
	%ED rating			
	Short-time rating			
Standard output during acceleration/deceleration [kW]			7.5	9.2
Actual acceleration/deceleration output (Note 2) [kW]			9	11.0
Continuous base rotation speed [r/min]			2800	2800
Max. rotation speed in constant output range [r/min]			8000	8000
Maximum rotation speed [r/min]			12000	12000
Continuous rated torque [N·m]			12.6	12.6
Motor inertia [kg·m ²]			0.0075	0.0075
Degree of protection (The shaft-through portion is excluded.)			IP54	IP54
Outline dimension drawing (flange type)				
	[mm]		327	327
Flange fitting diameter [mm]			ø150	ø150
Shaft diameter [mm]			ø28	ø28
Mass [kg]			24	24
With leg			Not possible	Not possible

(Note 1) Only the combination designated in this manual can be used for the motor and drive unit. Always use the designated combination.
 (Note 2) Actual acceleration/deceleration output is 1.2-fold of "Standard output during acceleration/deceleration" or "Short time rated output".
 (Note 3) IP code classifies the degree of protection of the motor body. It does not apply to the other electronic parts such as the cooling fan and the encoder.

■SJ-DG Series (High-output specifications)

Motor type		SJ-DG3.7/120-03T	SJ-DG5.5/120-04T	SJ-DG7.5/120-05T	SJ-DG11/100-03T	SJ-DG11/120-03T	
Compatible drive unit	1-axis type	MDS-E-SP-	160	160	160	200	160
	2-axis type	MDS-E-SP2-	-	-	-	-	16080(L)
	Multi-hybrid type	MDS-EM-SPV3-	10040, 10080, 16040S	16040, 16080, 16040S	16040, 16080, 16040S	20080, 200120	16040, 16080, 16040S
	Regenerative resistor type	MDS-EJ-SP-	-	-	-	-	-
Output	%ED rating						
	Short-time rating						
	Continuous rating						
Standard output during acceleration/deceleration [kW]			5.5	7.5	11.0	15.0	11.0
Actual acceleration/deceleration output (Note 2) [kW]			6.6	9.0	13.2	18.0	13.2
Continuous base rotation speed [r/min]			1500	1500	1500	1500	1500
Max. rotation speed in constant output range [r/min]			10000	7000	8000	6000	6000
Maximum rotation speed [r/min]			12000	12000	12000	10000	12000
Continuous rated torque [N·m]			14.0	23.6	35.0	47.7	47.7
Motor inertia [kg·m ²]			0.0066	0.012	0.022	0.029	0.029
Degree of protection (The shaft-through portion and rotation seal portion are excluded.)			IP54	IP54	IP54	IP54	IP54
Outline dimension drawing (flange type)							
	[mm]	327	417	439	489	489	489
Flange fitting diameter [mm]		ø150	ø150	ø180	ø180	ø180	ø180
Shaft diameter [mm]		ø28	ø28	ø32	ø48	ø48	ø48
Mass [kg]		24	37	50	61	61	61
With leg		Not possible	Not possible	Not possible	Not possible	Not possible	Not possible

Motor type		SJ-DG15/120-02T-K			
Compatible drive unit	1-axis type	MDS-E-SP-	200		240
	2-axis type	MDS-E-SP2-	-		-
	Multi-hybrid type	MDS-EM-SPV3-	20080, 200120		-
	Regenerative resistor type	MDS-EJ-SP-	-		-
Output	Acceleration/Deceleration				
	%ED rating				
	Short-time rating				
Standard output during acceleration/deceleration [kW]			18.5	18.5	25.0
Actual acceleration/deceleration output (Note 2) [kW]			22.2	22.2	30
Continuous base rotation speed [r/min]			1350	3550	1350
Max. rotation speed in constant output range [r/min]			5500	12000	5500
Maximum rotation speed [r/min]				12000	
Continuous rated torque [N·m]			77.8	29.6	77.8
Motor inertia [kg·m ²]				0.086	
Degree of protection (The shaft-through portion and rotation seal portion are excluded.)				IP54	
Outline dimension drawing (flange type)					
	[mm]		438.5	438.5	438.5
Flange fitting diameter [mm]			ø230	ø230	ø230
Shaft diameter [mm]			ø48	ø48	ø48
Mass [kg]			93	93	93
With leg			Not possible	Not possible	Not possible

(Note 1) Only the combination designated in this manual can be used for the motor and drive unit. Always use the designated combination.
 (Note 2) Actual acceleration/deceleration output is 1.2-fold of "Standard output during acceleration/deceleration" or "Short time rated output".
 (Note 3) IP code classifies the degree of protection of the motor body. It does not apply to the other electronic parts such as the cooling fan and the encoder.

■SJ-DJ Series (Compact & lightweight specifications)

Motor type		SJ-DJ5.5/100-01	SJ-DJ5.5/120-01	SJ-DJ7.5/100-01
Compatible drive unit	1-axis type	MDS-E-SP-80	80	160
	2-axis type	MDS-E-SP2-80	80	16080(M)
	Multi-hybrid type	MDS-EM-SPV3-16080(M)	16080(M)	16080(M)
	Regenerative resistor type	MDS-EJ-SP-100	100	120
Output	%ED rating			
	Short-time rating			
Standard output during acceleration/deceleration [kW]		5.5	5.5	7.5
Actual acceleration/deceleration output (Note 2) [kW]		6.6	6.6	9
Base rotation speed	Short-time	1500	1500	1500
	Continuous	2000	2000	2000
Max. rotation speed in constant output range [r/min]		4500	4500	4500
Maximum rotation speed [r/min]		10000	12000	10000
Continuous rated torque [N·m]		17.7	17.7	26.3
Motor inertia [kg·m ²]		0.0074	0.0074	0.013
Degree of protection (The shaft-through portion is excluded.)		IP54	IP54	IP54
Outline dimension drawing (flange type)	[mm]			
		174 SQ. 327	174 SQ. 327	174 SQ. 417
Flange fitting diameter [mm]		ø150	ø150	ø150
Shaft diameter [mm]		ø28	ø28	ø28
Mass [kg]		26	26	39
With leg		Possible	Possible	Possible

■SJ-DL Series (Low-inertia specifications)

Motor type		SJ-DL0.75/100-01	SJ-DL1.5/100-01	SJ-DL3.7/240-01T
Compatible drive unit	1-axis type	MDS-E-SP-20	40	200
	2-axis type	MDS-E-SP2-20	40	-
	Multi-hybrid type	MDS-EM-SPV3-	-	20080, 200120
	Regenerative resistor type	MDS-EJ-SP-	-	-
Output	Acceleration/Deceleration			
	Short-time rating			
Standard output during acceleration/deceleration [kW]		0.9	1.5	15.0
Actual acceleration/deceleration output (Note 2) [kW]		1.1	1.8	18.0
Continuous base rotation speed [r/min]		1500	1500	3000
Max. rotation speed in constant output range [r/min]		10000	10000	24000
Maximum rotation speed [r/min]		10000	10000	24000
Continuous rated torque [N·m]		2.55	4.8	4.8
Motor inertia [kg·m ²]		0.0011	0.0019	0.0024
Degree of protection (The shaft-through portion is excluded.)		IP54	IP54	IP54
Outline dimension drawing (flange type)	[mm]			
		130 SQ. 264	130 SQ. 317	130 SQ. 375
Flange fitting diameter [mm]		ø110	ø110	ø110
Shaft diameter [mm]		ø22	ø22	ø22
Mass [kg]		10	14	17
With leg		Not possible	Not possible	Not possible

Motor type		SJ-DJ7.5/120-01	SJ-DJ11/100-01	SJ-DJ15/80-01
Compatible drive unit	1-axis type	MDS-E-SP-160	160	200
	2-axis type	MDS-E-SP2-16080(L)	16080(L)	-
	Multi-hybrid type	MDS-EM-SPV3-10040, 10080, 16040S	16040, 16080, 16040S	20080, 200120
	Regenerative resistor type	MDS-EJ-SP-120	160	-
Output	%ED rating			
	Short-time rating			
Standard output during acceleration/deceleration [kW]		7.5	11	15
Actual acceleration/deceleration output (Note 2) [kW]		9	13.2	18
Base rotation speed	Short-time	1500	1500	1500
	Continuous	2000	2000	2000
Max. rotation speed in constant output range [r/min]		4500	4500	4000
Maximum rotation speed [r/min]		12000	10000	8000
Continuous rated torque [N·m]		26.3	35.8	52.5
Motor inertia [kg·m ²]		0.013	0.023	0.031
Degree of protection (The shaft-through portion is excluded.)		IP54	IP54	IP54
Outline dimension drawing (flange type)	[mm]			
		174 SQ. 417	204 SQ. 439	204 SQ. 489
Flange fitting diameter [mm]		ø150	ø180	ø180
Shaft diameter [mm]		ø28	ø32	ø48
Mass [kg]		39	53	64
With leg		Possible	Possible	Possible

Motor type		SJ-DL5.5/150-01T	SJ-DL5.5/200-01T	SJ-DL5.5/240-05T	SJ-DL7.5/150-01T
Compatible drive unit	1-axis type	MDS-E-SP-160	160	200	160
	2-axis type	MDS-E-SP2-16080(L)	16080(L)	-	16080(L)
	Multi-hybrid type	MDS-EM-SPV3-16040, 16080, 16040S	-	20080, 200120	16040, 16080, 16040S
	Regenerative resistor type	MDS-EJ-SP-	-	-	-
Output	Acceleration/Deceleration				
	Short-time rating				
Standard output during acceleration/deceleration [kW]		11	11	22.0	11
Actual acceleration/deceleration output (Note 2) [kW]		13.2	13.2	26.4	13.2
Continuous base rotation speed [r/min]		2500	2500	2500	1500
Max. rotation speed in constant output range [r/min]		15000	20000	20000	8000
Maximum rotation speed [r/min]		15000	20000	24000	15000
Continuous rated torque [N·m]		14.1	14.1	14.1	35.0
Motor inertia [kg·m ²]		0.0046	0.0046	0.0042	0.016
Degree of protection (The shaft-through portion is excluded.)		IP54	IP54	IP54	IP54
Outline dimension drawing (flange type)	[mm]				
		174 SQ. 377	174 SQ. 377	174 SQ. 377	204 SQ. 489
Flange fitting diameter [mm]		ø150	ø150	ø150	ø180
Shaft diameter [mm]		ø28	ø28	ø22	ø32
Mass [kg]		30	30	27	56
With leg		Not possible	Not possible	Not possible	Not possible

(Note 1) Only the combination designated in this manual can be used for the motor and drive unit. Always use the designated combination.
 (Note 2) Actual acceleration/deceleration output is 1.2-fold of "Standard output during acceleration/deceleration" or "Short time rated output".
 (Note 3) %ED is a load time ratio of operating time relative to a 10-minute cycle time. At 25%ED, for example, the operating time is 2.5 minutes and non-operation time is 7.5 minutes of a 10-minute cycle time.
 (Note 4) IP code classifies the degree of protection of the motor body. It does not apply to the other electronic parts such as the cooling fan and the encoder.

(Note 1) Only the combination designated in this manual can be used for the motor and drive unit. Always use the designated combination.
 (Note 2) Actual acceleration/deceleration output is 1.2-fold of "Standard output during acceleration/deceleration" or "Short time rated output".
 (Note 3) IP code classifies the degree of protection of the motor body. It does not apply to the other electronic parts such as the cooling fan and the encoder.

■SJ-DL Series (Hollow shaft specifications)

Motor type		SJ-DL5.5/200-01T-S	
Compatible drive unit	1-axis type	MDS-E-SP-	160
	2-axis type	MDS-E-SP2-	16080(L)
	Multi-hybrid type	MDS-EM-SPV3-	-
	Regenerative resistor type	MDS-EJ-SP-	-
Output	Acceleration/Deceleration	<input type="checkbox"/>	
	Short-time rating	<input type="checkbox"/>	
Standard output during acceleration/deceleration [kW]		11	
Actual acceleration/deceleration output (Note 2) [kW]		13.2	
Continuous base rotation speed [r/min]		2500	
Max. rotation speed in constant output range [r/min]		20000	
Maximum rotation speed [r/min]		20000	
Continuous rated torque [N·m]		14.1	
Motor inertia [kg·m ²]		0.0046	
Degree of protection (The shaft-through portion is excluded.)		IP54	
Outline dimension drawing (flange type)			
	[mm]		
Flange fitting diameter	[mm]	ø150	
Shaft diameter	[mm]	ø22	
Mass	[kg]	28	
With leg		Not possible	

■SJ-DN Series (High-torque specifications)

Motor type		SJ-DN7.5/80-01	SJ-DN11/80-01	SJ-DN15/80-01	SJ-DN18.5/80-01				
Compatible drive unit	1-axis type	MDS-E-SP-	160	200	200				
	2-axis type	MDS-E-SP2-	16080(L)	-	-				
	Multi-hybrid type	MDS-EM-SPV3-	10040, 10080, 16040S	20080, 200120	20080, 200120	20080, 200120			
	Regenerative resistor type	MDS-EJ-SP-	-	-	-	-			
Output	%ED rating	<input type="checkbox"/>							
	Short-time rating	<input type="checkbox"/>							
Standard output during acceleration/deceleration [kW]		7.5		11		15		18.5	
Actual acceleration/deceleration output (Note 2) [kW]		9		13.2		18		22.2	
Continuous base rotation speed [r/min]		1000		1000		900		1000	
Max. rotation speed in constant output range [r/min]		2500		5000		5000		3500	
Maximum rotation speed [r/min]		8000		8000		8000		8000	
Continuous rated torque [N·m]		52.5		85.9		117		143	
Motor inertia [kg·m ²]		0.031		0.10		0.14		0.16	
Degree of protection (The shaft-through portion is excluded.)		IP54		IP54		IP54		IP54	
Outline dimension drawing (flange type)									
	[mm]								
Flange fitting diameter	[mm]	ø180		ø230		ø230		ø230	
Shaft diameter	[mm]	ø48		ø48		ø55		ø55	
Mass	[kg]	86		103		131		147	
With leg		Possible		Possible		Possible		Possible	

(Note 1) Only the combination designated in this manual can be used for the motor and drive unit. Always use the designated combination.
 (Note 2) Actual acceleration/deceleration output is 1.2-fold of "Standard output during acceleration/deceleration" or "Short time rated output".
 (Note 3) IP code classifies the degree of protection of the motor body. It does not apply to the other electronic parts such as the cooling fan and the encoder.

■SJ-V Series (Normal specifications)

Motor type		SJ-V2.2-01T	SJ-V3.7-02ZT
Compatible drive unit	1-axis type	MDS-E-SP-	40
	2-axis type	MDS-E-SP2-	40
	Multi-hybrid type	MDS-EM-SPV3-	-
			80
Output	Short-time rating	<input type="checkbox"/>	
	Continuous rating	<input type="checkbox"/>	
Standard output during acceleration/deceleration [kW]		2.2	
Actual acceleration/deceleration output (Note 2) [kW]		2.6	
Continuous base rotation speed [r/min]		1500	
Max. rotation speed in constant output range [r/min]		6000	
Maximum rotation speed [r/min]		10000	
Continuous rated torque [N·m]		9.5	
Motor inertia [kg·m ²]		0.00675	
Degree of protection		IP44	
Outline dimension drawing (flange type)			
	[mm]		
Flange fitting diameter	[mm]	ø150	
Shaft diameter	[mm]	ø28	
Mass	[kg]	25	
With leg		Possible	

Motor type		SJ-V15-09ZT	SJ-V18.5-01ZT	SJ-V18.5-04ZT	SJ-V22-01ZT				
Compatible drive unit	1-axis type	MDS-E-SP-	200	200	240				
	2-axis type	MDS-E-SP2-	-	-	-				
	Multi-hybrid type	MDS-EM-SPV3-	20080, 200120	20080, 200120	-	-			
Output	Short-time rating	<input type="checkbox"/>							
	Continuous rating	<input type="checkbox"/>							
Standard output during acceleration/deceleration [kW]		15		18.5		22			
Actual acceleration/deceleration output (Note 2) [kW]		18		22.2		26.4			
Continuous base rotation speed [r/min]		1500		1500		1500			
Max. rotation speed in constant output range [r/min]		6000		4500		6000			
Maximum rotation speed [r/min]		8000		8000		8000			
Continuous rated torque [N·m]		70		95.5		118			
Motor inertia [kg·m ²]		0.0575		0.0575		0.08			
Degree of protection		IP44		IP44		IP44			
Outline dimension drawing (flange type)									
	[mm]								
Flange fitting diameter	[mm]	ø230		ø230		ø230		ø230	
Shaft diameter	[mm]	ø48		ø48		ø48		ø55	
Mass	[kg]	110		110		110		135	
With leg		Possible		Possible		Possible		Possible	

(Note 1) Only the combination designated in this manual can be used for the motor and drive unit. Always use the designated combination.
 (Note 2) Actual acceleration/deceleration output is 1.2-fold of "Standard output during acceleration/deceleration" or "Short time rated output".
 (Note 3) IP code classifies the degree of protection of the motor body. It does not apply to the other electronic parts such as the cooling fan and the encoder.

■SJ-V Series (Normal specifications)

Motor type		SJ-V22-04ZT	SJ-V22-06ZT	SJ-V26-01ZT	SJ-V37-01ZT
Compatible drive unit	1-axis type	MDS-E-SP-320	240	320	400
	2-axis type	MDS-E-SP2-	-	-	-
	Multi-hybrid type	MDS-EM-SPV3-	-	-	-
Output	Short-time rating				
	Continuous rating				
Standard output during acceleration/deceleration [kW]		22	15	26	37
Actual acceleration/deceleration output (Note 2) [kW]		26.4	18	31.2	44.4
Continuous base rotation speed [r/min]		1500	1500	1500	1150
Max. rotation speed in constant output range [r/min]		6000	9500	6000	3450
Maximum rotation speed [r/min]		8000	10000	8000	6000
Continuous rated torque [N·m]		118	70.0	140	249
Motor inertia [kg·m ²]		0.08	0.0575	0.0925	0.34
Degree of protection		IP44	IP44	IP44	IP44
Outline dimension drawing (flange type) [mm]					
Flange fitting diameter [mm]		ø230	ø230	ø230	ø300
Shaft diameter [mm]		ø55	ø48	ø55	ø60
Mass [kg]		135	110	155	300
With leg		Possible	Possible	Possible	Possible

Motor type		SJ-V45-01ZT	SJ-V55-01ZT
Compatible drive unit	1-axis type	MDS-E-SP-640	640
	2-axis type	MDS-E-SP2-	-
	Multi-hybrid type	MDS-EM-SPV3-	-
Output	Short-time rating		
	Continuous rating		
Standard output during acceleration/deceleration [kW]		45	55
Actual acceleration/deceleration output (Note 2) [kW]		54	66
Continuous base rotation speed [r/min]		1500	1150
Max. rotation speed in constant output range [r/min]		4500	3450
Maximum rotation speed [r/min]		6000	4500
Continuous rated torque [N·m]		236	374
Motor inertia [kg·m ²]		0.34	0.8475
Degree of protection		IP44	IP44
Outline dimension drawing (flange type) [mm]			
Flange fitting diameter [mm]		ø300	ø450
Shaft diameter [mm]		ø60	ø75
Mass [kg]		300	450
With leg		Possible	Possible

■SJ-V Series (Wide range constant output specifications)

Motor type		SJ-V11-01T	SJ-V11-09T	SJ-V15-03T	SJ-V18.5-03T
Compatible drive unit	1-axis type	MDS-E-SP-160	160	200	240
	2-axis type	MDS-E-SP2-16080(L)	16080(L)	-	-
	Multi-hybrid type	MDS-EM-SPV3-16040, 16080, 16040S	16040, 16080, 16040S	20080, 200120	-
Output	Short-time rating				
	Continuous rating				
Standard output during acceleration/deceleration [kW]		5.5	7.5	9	11
Actual acceleration/deceleration output (Note 2) [kW]		6.6	9	10.8	13.2
Continuous base rotation speed [r/min]		750	750	750	750
Max. rotation speed in constant output range [r/min]		6000	6000	6000	6000
Maximum rotation speed [r/min]		6000	6000	6000	6000
Continuous rated torque [N·m]		47.1	70.0	95.5	115
Motor inertia [kg·m ²]		0.03	0.0575	0.0575	0.08
Degree of protection		IP44	IP44	IP44	IP44
Outline dimension drawing (flange type) [mm]					
Flange fitting diameter [mm]		ø180	ø230	ø230	ø230
Shaft diameter [mm]		ø48	ø48	ø48	ø55
Mass [kg]		70	110	110	135
With leg		Possible	Possible	Possible	Possible

Motor type		SJ-V22-05T	SJ-V22-09T	SJ-VK22-19ZT
Compatible drive unit	1-axis type	MDS-E-SP-320	320	320
	2-axis type	MDS-E-SP2-	-	-
	Multi-hybrid type	MDS-EM-SPV3-	-	-
Output	Short-time rating			
	Continuous rating			
Standard output during acceleration/deceleration [kW]		15	18.5	18.5
Actual acceleration/deceleration output (Note 2) [kW]		18	22.2	22.2
Continuous base rotation speed [r/min]		750	600	400
Max. rotation speed in constant output range [r/min]		6000	3500	750
Maximum rotation speed [r/min]		6000	4500	6000
Continuous rated torque [N·m]		140	239	310
Motor inertia [kg·m ²]		0.08	0.308	0.34
Degree of protection		IP44	IP44	IP44
Outline dimension drawing (flange type) [mm]				
Flange fitting diameter [mm]		ø230	ø300	ø300
Shaft diameter [mm]		ø55	ø60	ø60
Mass [kg]		135	280	300
With leg		Possible	Possible	Possible

(Note 1) Only the combination designated in this manual can be used for the motor and drive unit. Always use the designated combination.
 (Note 2) Actual acceleration/deceleration output is 1.2-fold of "Standard output during acceleration/deceleration" or "Short time rated output".
 (Note 3) IP code classifies the degree of protection of the motor body. It does not apply to the other electronic parts such as the cooling fan and the encoder.

(Note 1) Only the combination designated in this manual can be used for the motor and drive unit. Always use the designated combination.
 (Note 2) Actual acceleration/deceleration output is 1.2-fold of "Standard output during acceleration/deceleration" or "Short time rated output".
 (Note 3) IP code classifies the degree of protection of the motor body. It does not apply to the other electronic parts such as the cooling fan and the encoder.

■SJ-VL Series (Low-inertia specifications)

Motor type		SJ-VL2.2-02ZT	SJ-VL11-02FZT	SJ-VL11-05FZT-S01 **
Compatible drive unit	1-axis type	MDS-E-SP-40	160	160
	2-axis type	MDS-E-SP2-40	16080(L)	16080(L)
	Multi-hybrid type	MDS-EM-SPV3-	16040, 16080, 16040S	16040, 16080, 16040S
Output	Acceleration/Deceleration			
	Short-time rating			
	Continuous rating			
Standard output during acceleration/deceleration [kW]		2.2	11	11
Actual acceleration/deceleration output (Note 2) [kW]		2.6	13.2	13.2
Continuous base rotation speed [r/min]		3000	1500	5000
Max. rotation speed in constant output range [r/min]		15000	15000	20000
Maximum rotation speed [r/min]		15000	15000	20000
Continuous rated torque [N·m]		4.8	14.0	2.86
Motor inertia [kg·m ²]		0.0024	0.003	0.0024
Degree of protection		IP44	IP44	IP44
Outline dimension drawing (flange type)	[mm]			
	Flange fitting diameter [mm]	ø110	ø150	ø110
Shaft diameter [mm]		ø22	ø28	ø22
Mass [kg]		20	42	20
With leg		Not possible	Not possible	Not possible

*1 The acceleration/deceleration frequency is limited by the regenerative resistor.

(Note 1) Only the combination designated in this manual can be used for the motor and drive unit. Always use the designated combination.

(Note 2) Actual acceleration/deceleration output is 1.2-fold of "Standard output during acceleration/deceleration" or "Short time rated output".

(Note 3) IP code classifies the degree of protection of the motor body. It does not apply to the other electronic parts such as the cooling fan and the encoder.

BUILT-IN SPINDLE MOTOR 200V

■SJ-BG Series (Normal specifications)

Motor type (Note 1)		SJ-BG090A/300-01 (R)	SJ-BG090B/300-03	SJ-BG090D/300-03	SJ-BG110F/240-01
Compatible drive unit	MDS-E-SP-	20	40	160	80
	MDS-E-SP2-	20	40	16080(L)	80
Output	Acceleration/Deceleration				
	%ED rating				
	Continuous rating				
Standard output during acceleration/deceleration [kW]		1.5	1.5	9.0	5.5
Actual acceleration/deceleration output (Note 3) [kW]		1.8	1.8	10.8	6.6
Continuous base rotation speed [r/min]		8400	6000	12000	3000
Maximum rotation speed [r/min]		30000	30000	30000	24000
Continuous rated torque [N·m]		0.85	1.91	4.38	9.5
Rotor inertia [kg·m ²]		0.00021	0.0004	0.0008	0.0026
Outline dimension drawing	[mm]				
	Stator [kg]	0.7	1.2	2.6	7.4
Rotor [kg]		0.4	0.7	1.4	3.2

Motor type (Note 1)		SJ-BG120A/200-01 (R)	SJ-BG120C/200-01 (R)	SJ-BG135D/200-01	
Compatible drive unit	MDS-E-SP-	80	80	320	
	MDS-E-SP2-	80	80	16080(M)	
Output	Acceleration/Deceleration				
	%ED rating				
	Continuous rating				
Standard output during acceleration/deceleration [kW]		3.7	5.5	3.7	15
Actual acceleration/deceleration output (Note 3) [kW]		4.4	6.6	4.4	18.0
Continuous base rotation speed [r/min]		2500	5500	2500	3280
Maximum rotation speed [r/min]		15000	20000	20000	8000
Continuous rated torque [N·m]		5.7	2.6	8.4	32.0
Rotor inertia [kg·m ²]		0.0016 (0.0014)		0.0032 (0.0027)	
Outline dimension drawing	[mm]				
	Stator [kg]	3.0		12	
Rotor [kg]		1.3		3.3	

(Note 1) Please contact your Mitsubishi Electric dealer for the special products not listed above.

(Note 2) Only the combination designated in this manual can be used for the motor and drive unit. Always use the designated combination.

(Note 3) Actual acceleration/deceleration output is 1.2-fold of "Standard output during acceleration/deceleration" or "Short time rated output".

(Note 4) A value in brackets is for the motor type which has (R) in the end of the type name.

■SJ-BG Series (Normal specifications)

Motor type (Note 1)		SJ-BG150D/150-01 □	SJ-BG160B/150-01 □ (R)		SJ-BG160D/150-01 □ (R)
Compatible drive unit	MDS-E-SP-	80	40	80	160
	MDS-E-SP2-	80 16080(M)	40	80 16080(M)	16080(L)
Output Acceleration/Deceleration %ED rating Continuous rating					
	Standard output during acceleration/deceleration [kW]	5.5	3.7	3.7	7.5
	Actual acceleration/deceleration output (Note 3) [kW]	6.6	4.44	4.44	9
	Continuous base rotation speed [r/min]	2500	3500	1300	1770
Maximum rotation speed [r/min]	15000	15000	15000	15000	
Continuous rated torque [N·m]	14.1	6.0	16.2	20.0	
Rotor inertia [kg·m ²]	0.0057	0.0048(0.0042)	0.0048(0.0042)	0.0048(0.0042)	
Outline dimension drawing					
	Mass	Stator [kg] Rotor [kg]	8.1 3.7	7.1 2.9(2.3)	7.1 2.9(2.3)

■SJ-BG Series (Normal specifications)

Motor type (Note 1)		SJ-BG180F/150-01 □		SJ-BG180H/150-01 □	
Compatible drive unit	MDS-E-SP-	400		400	
	MDS-E-SP2-	-		-	
Output Acceleration/Deceleration %ED rating Continuous rating					
	Standard output during acceleration/deceleration [kW]	22	37	26	37
	Actual acceleration/deceleration output (Note 3) [kW]	26.4	44.4	31.2	44.4
	Continuous base rotation speed [r/min]	1650	5700	1200	4700
Maximum rotation speed [r/min]	4000	15000	6000	15000	
Continuous rated torque [N·m]	86.8	36.9	119	52.8	
Rotor inertia [kg·m ²]	0.023		0.029		
Outline dimension drawing					
	Mass	Stator [kg] Rotor [kg]	27 10	33 12	

Motor type (Note 1)		SJ-BG160D/150-02 □ (R)	SJ-BG180B/150-01 □		SJ-BG180D/150-01 □	
Compatible drive unit	MDS-E-SP-	160	400		400	
	MDS-E-SP2-	16080(L)	-		-	
Output Acceleration/Deceleration %ED rating Continuous rating						
	Standard output during acceleration/deceleration [kW]	9.0	18.5	30	22	30
	Actual acceleration/deceleration output (Note 3) [kW]	10.8	22.2	36	26.4	36
	Continuous base rotation speed [r/min]	1500	2300	6000	2000	6500
Maximum rotation speed [r/min]	15000	6000	15000	6000	15000	
Continuous rated torque [N·m]	23.6	45.7	29.4	71.6	32.3	
Rotor inertia [kg·m ²]	0.0070(0.0061)	0.012		0.018		
Outline dimension drawing						
	Mass	Stator [kg] Rotor [kg]	11 4.2(3.3)	14 5.1	21 8.0	

*1 The cycle times for 10%ED rating, 15%ED rating, and 25%ED rating (Low-speed coil) are 5 minutes.

(Note 1) Please contact your Mitsubishi Electric dealer for the special products not listed above.

(Note 2) Only the combination designated in this manual can be used for the motor and drive unit. Always use the designated combination.

(Note 3) Actual acceleration/deceleration output is 1.2-fold of "Standard output during acceleration/deceleration" or "Short time rated output".

(Note 4) A value in brackets is for the motor type which has (R) in the end of the type name.

Motor type (Note 1)		SJ-BG240H/100-01 □		SJ-BG300L/080-01 □	
Compatible drive unit	MDS-E-SP-	400		640	
	MDS-E-SP2-	-		-	
Output Acceleration/Deceleration %ED rating Continuous rating					
	Standard output during acceleration/deceleration [kW]	30	45	37	55
	Actual acceleration/deceleration output (Note 3) [kW]	36	54	44.4	66
	Continuous base rotation speed [r/min]	700	2500	350	1800
Maximum rotation speed [r/min]	2000	10000	1500	8000	
Continuous rated torque [N·m]	252	99.3	600	196	
Rotor inertia [kg·m ²]	0.14		0.48		
Outline dimension drawing					
	Mass	Stator [kg] Rotor [kg]	63 32	107 63	

*1 The cycle times for 10%ED rating, 15%ED rating, 25%ED rating (Low-speed coil), and 25%ED rating (High-speed coil) are 5 minutes.

(Note 1) Please contact your Mitsubishi Electric dealer for the special products not listed above.

(Note 2) Only the combination designated in this manual can be used for the motor and drive unit. Always use the designated combination.

(Note 3) Actual acceleration/deceleration output is 1.2-fold of "Standard output during acceleration/deceleration" or "Short time rated output".

■SJ-BG Series (High-speed specifications)

Motor type (Note 1)		SJ-BG160D/200-03		SJ-BG180F/200-01		
Compatible drive unit		240		400		
		MDS-E-SP- MDS-E-SP2-		-		
Output Acceleration/Deceleration %ED rating Continuous rating	Low-speed coil		High-speed coil		High-speed coil	
	Standard output during acceleration/deceleration [kW]		15		37	
	Actual acceleration/deceleration output (Note 3) [kW]		18.0		44.4	
Continuous base rotation speed [r/min]		2700		5700		
Maximum rotation speed [r/min]		5500		20000		
Continuous rated torque [N·m]		26.5		36.9		
Rotor inertia [kg·m ²]		0.0062		0.023		
Outline dimension drawing [mm]						
Mass	Stator [kg]	10		27		
	Rotor [kg]	3.4		10		

■SJ-B Series

Motor type (Note 1)		SJ-2B4002T	SJ-2B4004T	SJ-2B4003T
Compatible drive unit		20	40	40
		MDS-E-SP- MDS-E-SP2-	-	-
Output Acceleration/Deceleration Short-time rating Continuous rating				
	Standard output during acceleration/deceleration [kW]		0.75	
	Actual acceleration/deceleration output (Note 3) [kW]		1.8	
	Continuous base rotation speed [r/min]		3000	
Maximum rotation speed [r/min]		15000		
Continuous rated torque [N·m]		2.39		
Rotor inertia [kg·m ²]		0.00078		
Outline dimension drawing [mm]				
Mass	Stator [kg]	2.2		3.9
	Rotor [kg]	0.9		1.7

Motor type (Note 1)		SJ-BG240H/130-01		
Compatible drive unit		400		
		MDS-E-SP- MDS-E-SP2-		
Output Acceleration/Deceleration %ED rating Continuous rating	Low-speed coil		High-speed coil	
	Standard output during acceleration/deceleration [kW]		30	
	Actual acceleration/deceleration output (Note 3) [kW]		36	
Continuous base rotation speed [r/min]		700		
Maximum rotation speed [r/min]		2000		
Continuous rated torque [N·m]		252		
Rotor inertia [kg·m ²]		0.14		
Outline dimension drawing [mm]				
Mass	Stator [kg]	63		
	Rotor [kg]	32		

*1 The cycle times for 10%ED rating, 15%ED rating, 25%ED rating (Low-speed coil), and 25%ED rating (High-speed coil) are 5 minutes.

(Note 1) Please contact your Mitsubishi Electric dealer for the special products not listed above.

(Note 2) Only the combination designated in this manual can be used for the motor and drive unit. Always use the designated combination.

(Note 3) Actual acceleration/deceleration output is 1.2-fold of "Standard output during acceleration/deceleration" or "Short time rated output".

Motor type (Note 1)		SJ-2B4501TK	SJ-2B6611TK	SJ-2B4502TK
Compatible drive unit		200	200	320
		MDS-E-SP- MDS-E-SP2-	-	-
Output Acceleration/Deceleration Short-time rating Continuous rating	Low-speed coil		High-speed coil	
	Standard output during acceleration/deceleration [kW]		15	
	Actual acceleration/deceleration output (Note 3) [kW]		18	
Continuous base rotation speed [r/min]		700		
Maximum rotation speed [r/min]		2250		
Continuous rated torque [N·m]		102		
Rotor inertia [kg·m ²]		0.08		
Outline dimension drawing [mm]				
Mass	Stator [kg]	29		37
	Rotor [kg]	18		24

(Note 1) Please contact your Mitsubishi Electric dealer for the special products not listed above.

(Note 2) Only the combination designated in this manual can be used for the motor and drive unit. Always use the designated combination.

(Note 3) Actual acceleration/deceleration output is 1.2-fold of "Standard output during acceleration/deceleration" or "Short time rated output".

■SJ-B Series

Motor type (Note 1)		SJ-2B602TK		SJ-2B4601TK		SJ-2B6605TK		
Compatible drive unit		MDS-E-SP-320 MDS-E-SP2-		320		240		
Output Acceleration/Deceleration Short-time rating Continuous rating								
	Standard output during acceleration/deceleration [kW]		15		26		15	
	Actual acceleration/deceleration output (Note 3) [kW]		18		31.2		18	
	Continuous base rotation speed [r/min]		550		1250		440	
Maximum rotation speed [r/min]		2000		3500		1500		
Continuous rated torque [N·m]		191		168		239		
Rotor inertia [kg·m ²]		0.133		0.105		0.173		
Outline dimension drawing [mm]								
Mass	Stator [kg]	49		55		63		
	Rotor [kg]	25		24		33		

■SJ-B Series

Motor type (Note 1)		SJ-2B6720TK		SJ-2B6705TK		SJ-2B6711TK		
Compatible drive unit		MDS-E-SP-320 MDS-E-SP2-		200		320		
Output %ED rating Short-time rating Continuous rating								
	Standard output during acceleration/deceleration [kW]		22		11		22	
	Actual acceleration/deceleration output (Note 3) [kW]		26.4		13.2		26.4	
	Continuous base rotation speed [r/min]		700		250		400	
Maximum rotation speed [r/min]		1500		750		1700		
Continuous rated torque [N·m]		205		286		263		
Rotor inertia [kg·m ²]		0.20		0.288		0.280		
Outline dimension drawing [mm]								
Mass	Stator [kg]	45		65		65		
	Rotor [kg]	26		38		37		

Motor type (Note 1)		SJ-2B4503TK		SJ-2B6603TK		SJ-2B4602TK		
Compatible drive unit		MDS-E-SP-320 MDS-E-SP2-		320		320		
Output %ED rating Short-time rating Continuous rating								
	Standard output during acceleration/deceleration [kW]		15		22		22	
	Actual acceleration/deceleration output (Note 3) [kW]		18		26.4		26.4	
	Continuous base rotation speed [r/min]		475		600		720	
Maximum rotation speed [r/min]		2000		1500		2000		
Continuous rated torque [N·m]		221		239		245		
Rotor inertia [kg·m ²]		0.135		0.173		0.135		
Outline dimension drawing [mm]								
Mass	Stator [kg]	48		63		71		
	Rotor [kg]	31		33		31		

Motor type (Note 1)		SJ-2B6706TK		SJ-2B6721TK		SJ-2B6704TK		
Compatible drive unit		MDS-E-SP-400 MDS-E-SP2-		320		320		
Output Acceleration/Deceleration %ED rating Short-time rating Continuous rating								
	Standard output during acceleration/deceleration [kW]		26		22		22	
	Actual acceleration/deceleration output (Note 3) [kW]		31.2		26.4		26.4	
	Continuous base rotation speed [r/min]		450		500		475	
Maximum rotation speed [r/min]		2000		1500		1150		
Continuous rated torque [N·m]		318		353		302		
Rotor inertia [kg·m ²]		0.288		0.283		0.37		
Outline dimension drawing [mm]								
Mass	Stator [kg]	65		70		83		
	Rotor [kg]	38		35		49		

(Note 1) Please contact your Mitsubishi Electric dealer for the special products not listed above.
 (Note 2) Only the combination designated in this manual can be used for the motor and drive unit. Always use the designated combination.
 (Note 3) Actual acceleration/deceleration output is 1.2-fold of "Standard output during acceleration/deceleration" or "Short time rated output".

(Note 1) Please contact your Mitsubishi Electric dealer for the special products not listed above.
 (Note 2) Only the combination designated in this manual can be used for the motor and drive unit. Always use the designated combination.
 (Note 3) Actual acceleration/deceleration output is 1.2-fold of "Standard output during acceleration/deceleration" or "Short time rated output".

■SJ-B Series

Motor type (Note 1)		SJ-2B6709TK		SJ-2B6905TK		SJ-2B6908TK	
Compatible drive unit		MDS-E-SP-400 MDS-E-SP2-		320		320	
Output	%ED rating						
	Short-time rating						
Continuous rating							
Standard output during acceleration/deceleration [kW]		22	30	26	26	22	30
Actual acceleration/deceleration output (Note 3) [kW]		26.4	36	31.2	31.2	26.4	36
Continuous base rotation speed [r/min]		350	1000	420	1000	175	450
Maximum rotation speed [r/min]		1500	6000	1500	4000	1000	3300
Continuous rated torque [N·m]		409	210	500	210	819	467
Rotor inertia [kg·m ²]		0.37		0.853		1.105	
Outline dimension drawing [mm]							
Mass	Stator [kg]	83		110		143	
	Rotor [kg]	49		70		91	

■SJ-PMB Series

Motor type (Note 1)		SJ-PMB02215T-02		SJ-PMB04412T-B0		SJ-PMB14007T-01	
Compatible drive unit		MDS-E-SP-240 MDS-E-SP2-		200		320	
Output	%ED rating						
	Short-time rating						
Continuous rating							
Standard output during acceleration/deceleration [kW]		5.5	7.5	7.5	15	15	
Actual acceleration/deceleration output (Note 3) [kW]		6.6	9	9	18	18	
Continuous base rotation speed [r/min]		1500	1200	3000	750	1800	
Maximum rotation speed [r/min]		10000	3000	8000	1800	6000	
Continuous rated torque [N·m]		22.3	43.8	17.5	140	58.4	
Rotor inertia [kg·m ²]		0.006		0.0162		0.0633	
Outline dimension drawing [mm]							
Mass	Stator [kg]	4.4		14.0		30	
	Rotor [kg]	3.7		8.0		15	

(Note 1) Please contact your Mitsubishi Electric dealer for the special products not listed above.
 (Note 2) Only the combination designated in this manual can be used for the motor and drive unit. Always use the designated combination.
 (Note 3) Actual acceleration/deceleration output is 1.2-fold of "Standard output during acceleration/deceleration" or "Short time rated output".

Motor type (Note 1)		SJ-2B6906TK		SJ-2B6914TK	
Compatible drive unit		MDS-E-SP-400 MDS-E-SP2-		640	
Output	Acceleration/Deceleration				
	Short-time rating				
Continuous rating					
Standard output during acceleration/deceleration [kW]		22	37	30	45
Actual acceleration/deceleration output (Note 3) [kW]		26.4	44.4	36	54
Continuous base rotation speed [r/min]		175	600	240	470
Maximum rotation speed [r/min]		1000	3300	1000	3300
Continuous rated torque [N·m]		819	477	995	508
Rotor inertia [kg·m ²]		1.105		1.105	
Outline dimension drawing [mm]					
Mass	Stator [kg]	143		143	
	Rotor [kg]	91		91	

(Note 1) Please contact your Mitsubishi Electric dealer for the special products not listed above.
 (Note 2) Only the combination designated in this manual can be used for the motor and drive unit. Always use the designated combination.
 (Note 3) Actual acceleration/deceleration output is 1.2-fold of "Standard output during acceleration/deceleration" or "Short time rated output".

TOOL SPINDLE MOTOR 200V

■HG-JR Series

Motor type		HG-JR Series	
		HG-JR73	HG-JR153
Compatible drive unit	1-axis type MDS-E-SP-	40	80
	2-axis type MDS-E-SP2-	40	16080
	Regenerative resistor type MDS-EJ-SP-MDS-EJ-SP2-	80	-
Output		[N·m]	
Rated torque			
Max. torque			
Rated output		0.75	1.5
Max. rotation speed		8000	8000
Motor inertia		2.09	3.79
Degree of protection (The shaft-through portion is excluded.)		IP67	IP67
Outline dimension drawing			
Flange fitting diameter		ø80	ø80
Shaft diameter		ø16	ø16
Mass		3.7	5.9

■HG Series

Motor type		HG Series					
		HG□-D48					
		HG75	HG105	HG54	HG104	HG154	HG224
Compatible drive unit	1-axis type MDS-E-SP-	20	20	40	40	80	80
	2-axis type MDS-E-SP2-	20	20	40	40	80	80
	Regenerative resistor type MDS-EJ-SP-MDS-EJ-SP2-	40	40	80	80	16080	16080
Output		[N·m]					
Rated torque							
Max. torque							
Rated output		0.75	1.0	0.5	1.0	1.5	2.2
Rated rotation speed		4000			3000		
Max. rotation speed		4000			3000		
Motor inertia		2.62	5.12	6.13	11.9	17.8	23.7
Degree of protection (The shaft-through portion is excluded.)		IP67					
Outline dimension drawing (flange type)							
Flange fitting diameter		ø80	ø80	ø110	ø110	ø110	ø110
Shaft diameter		ø14	ø14	ø24	ø24	ø24	ø24
Mass		2.6	4.4	4.8	6.5	8.3	10.0

■HG Series

Motor type		HG Series			
		HG□-D47			
		HG46	HG56	HG96	
Compatible drive unit	1-axis type MDS-E-SP-	20	20	20	
	2-axis type MDS-E-SP2-	20	20	40	
	Regenerative resistor type MDS-EJ-SP-MDS-EJ-SP2-	20	20	20	
Output		[N·m]			
Rated torque					
Max. torque					
Rated output		0.4	0.5	0.9	
Max. rotation speed		6000	6000	6000	
Motor inertia		0.234	0.379	1.27	
Degree of protection (The shaft-through portion is excluded.)		IP67	IP67	IP67	
Outline dimension drawing					
Flange fitting diameter		ø50	ø50	ø70	
Shaft diameter		ø14	ø14	ø19	
Mass		1.2	1.6	2.9	

(Note 1) The above characteristics values are representative values. The maximum current and maximum torque are the values when combined with the drive unit.

(Note 2) Only the combination designated in this manual can be used for the motor and drive unit. Always use the designated combination.











Motor type		HG Series				
		HG□-D48				
		HG204	HG354	HG453	HG703	HG903
Compatible drive unit	1-axis type MDS-E-SP-	80	160	160	160	320
	2-axis type MDS-E-SP2-	80	16080	16080	16080	-
	Regenerative resistor type MDS-EJ-SP-MDS-EJ-SP2-	16080	-	-	-	-
Output		[N·m]				
Rated torque						
Max. torque						
Rated output		2.0	3.5	4.5	7.0	9.0
Rated rotation speed		3000				
Max. rotation speed		3000				
Motor inertia		38.3	75.0	112.0	154.0	196.0
Degree of protection (The shaft-through portion is excluded.)		IP67				
Outline dimension drawing (flange type)						
Flange fitting diameter		ø114.3	ø114.3	ø114.3	ø114.3	ø180
Shaft diameter		ø35	ø35	ø35	ø35	ø42
Mass		12.0	19.0	25.0	32.0	43.0











(Note 1) The above characteristics values are representative values. The maximum current and maximum torque are the values when combined with the drive unit.

(Note 2) Only the combination designated in this manual can be used for the motor and drive unit. Always use the designated combination.

SERVO MOTOR 400V

■HG-H Series





Motor type		HG-H75	HG-H105	HG-H54	HG-H104	HG-H154
Compatible drive unit	1-axis type MDS-EH-V1-	10	10	20	20	40
	2-axis type MDS-EH-V2-	10	10	20	20	40
	3-axis type MDS-EH-V3-	20	20	40	40	80
	Multi-hybrid type MDS-EMH-SPV3-	-	-	40	40	40
	Regenerative resistor type MDS-EJH-V1	-	-	8040, 10040	8040, 10040	8040, 10040, 10060
Output						
Stall torque	█					
Max. torque	□					
Rated output	[kW]	0.75	1.0	0.5	1.0	1.5
Max. rotation speed	[r/min]	5000				
Motor inertia	[$\times 10^{-4}$ kg·m ²]	2.62	5.12	6.13	11.9	17.8
Motor inertia with a brake	[$\times 10^{-4}$ kg·m ²]	2.70	5.20	8.26	14.0	20.0
Degree of protection (The shaft-through portion is excluded.)		IP67				
Outline dimension drawing (flange type) (Without a brake, Straight shaft, D48 encoder)	[mm]					
(Note) The total length will be 3.5mm longer when using a D51 or D74 encoder.						
Flange fitting diameter	[mm]	ø80	ø80	ø110	ø110	ø110
Shaft diameter	[mm]	ø14	ø14	ø24	ø24	ø24
Mass (with a brake)	[kg]	2.6(3.6)	4.4(5.3)	4.8(6.7)	6.5(8.5)	8.3(11.0)
Absolute position encoder compatible drive unit		EH, EJH	EH, EJH	EH, EMH, EJH	EH, EMH, EJH	EH, EMH, EJH

Motor type		HG-H224	HG-H204	HG-H354	HG-H453	HG-H703
Compatible drive unit	1-axis type MDS-EH-V1-	40	40	80	80	80W
	2-axis type MDS-EH-V2-	40	40	80	80	80W
	3-axis type MDS-EH-V3-	80	80	80W	80W	160
	Multi-hybrid type MDS-EMH-SPV3-	40	40	-	-	-
	Regenerative resistor type MDS-EJH-V1	-	-	8040, 10040, 10060	10060	10060
Output						
Stall torque	█					
Max. torque	□					
Rated output	[kW]	2.2	2.0	3.5	4.5	7.0
Max. rotation speed	[r/min]	4000				
Motor inertia	[$\times 10^{-4}$ kg·m ²]	23.7	38.3	75.0	112.0	154.0
Motor inertia with a brake	[$\times 10^{-4}$ kg·m ²]	25.9	47.9	84.7	122.0	164.0
Degree of protection (The shaft-through portion is excluded.)		IP67				
Outline dimension drawing (flange type) (Without a brake, Straight shaft, D48 encoder)	[mm]					
(Note) The total length will be 3.5mm longer when using a D51 or D74 encoder.						
Flange fitting diameter	[mm]	ø110	ø114.3	ø114.3	ø114.3	ø114.3
Shaft diameter	[mm]	ø24	ø35	ø35	ø35	ø35
Mass (with a brake)	[kg]	10.0(12.0)	12.0(18.0)	19.0(25.0)	25.0(31.0)	32.0(38.0)
Absolute position encoder compatible drive unit		EH	EH, EMH	EH, EMH	EH, EMH	EH





(Note 1) Only the combination designated in this manual can be used for the motor and drive unit. Always use the designated combination.

(Note 2) Stall torque is the maximum torque that can be output continuously when the motor rotation is stopped.

■HG-H Series

Motor type		HG-H903	HG-H1502
Compatible drive unit	1-axis type MDS-EH-V1-	160	200
	2-axis type MDS-EH-V2-	160	-
	3-axis type MDS-EH-V3-	-	-
	Multi-hybrid type MDS-EMH-SPV3-	-	-
	Regenerative resistor type MDS-EJH-V1	-	-
Output			
Stall torque	█		
Max. torque	□		
Rated output	[kW]	9.0	15.0
Max. rotation speed	[r/min]	3000	2500
Motor inertia	[$\times 10^{-4}$ kg·m ²]	196.0	489.0
Motor inertia with a brake	[$\times 10^{-4}$ kg·m ²]	206.0	-
Degree of protection (The shaft-through portion is excluded.)		IP67	IP44
Outline dimension drawing (flange type)	[mm]		
(Note) The total length will be 3.5mm longer when using a D51 or D74 encoder.			
Flange fitting diameter	[mm]	ø180	ø230
Shaft diameter	[mm]	ø42	ø65
Mass (with a brake)	[kg]	43.0(49.0)	120
Absolute position encoder compatible drive unit		EH	EH

■HQ-H Series

Motor type		HQ-H903	HQ-H1103
Compatible drive unit	1-axis type MDS-EH-V1-	160	160W
	2-axis type MDS-EH-V2-	160	-
Stall torque		70.0	110.0
Output			
Stall torque	█		
Max. torque	□		
Max. rotation speed	[r/min]	3000	3000
Motor inertia	[$\times 10^{-4}$ kg·m ²]	230.0	350.0
Motor inertia with a brake	[$\times 10^{-4}$ kg·m ²]	254.0	374.0
Degree of protection (The shaft-through portion is excluded.)		IP67	IP67
Outline dimension drawing (flange type) (Without a brake, Straight shaft, D48 encoder)	[mm]		
(Note) The total length will be 3.5mm longer when using a D51 or D74 encoder.			
Flange fitting diameter	[mm]	ø200	ø200
Shaft diameter	[mm]	ø55	ø55
Mass (with a brake)	[kg]	51.0(61.4)	74.0(84.4)
Absolute position encoder compatible drive unit		EH	EH

(Note 1) Only the combination designated in this manual can be used for the motor and drive unit. Always use the designated combination.

(Note 2) Stall torque is the maximum torque that can be output continuously when the motor rotation is stopped.

LINEAR SERVO MOTOR 400V

LM-F Series

Motor type	Primary side type	LM-FP5H-60M-1WW0
	Secondary side type	LM-FS50-□-1WW0
	Compatible drive unit	200
Compatible drive unit	1-axis type	MDS-EH-V1-
	2-axis type	MDS-EH-V2-
	Regenerative resistor type	MDS-EJH-V1-
Thrust force	Continuous (natural-cooling)	[N]
	Continuous (liquid-cooling)	
	Maximum	
Rated thrust	[N]	6000
Maximum speed (Note 1)	[m/s]	2.0
Magnetic attraction force	[N]	45000
Degree of protection		IP00
Outline dimension drawing	Primary side	[mm]
	Secondary side	
Mass [kg]	Primary side (coil)	67
	Secondary side (magnet)	20.0(480mm) 26.0(576mm)

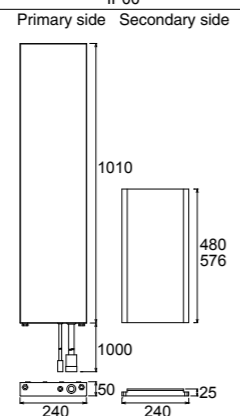
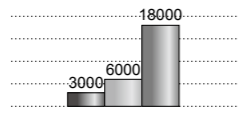

(Note 1) The maximum speed in actual use is either the linear scale's maximum speed or this specified value, whichever is smaller.
 (Note 2) Only the combination designated in this manual can be used for the motor and drive unit. Always use the designated combination.

SPINDLE MOTOR 400V

SJ-4-V Series (Normal)

Motor type	SJ-4-V2.2-03T	SJ-4-V3.7-03T	SJ-4-V5.5-07T	SJ-4-V7.5-12T	SJ-4-V7.5-13ZT
Compatible drive unit	MDS-EH-SP-20 MDS-EMH-SPV3-	20	20	40	40
Output	2.2	3.7	5.5	7.5	7.5
Short-time rating	2.2	3.7	5.5	7.5	7.5
Continuous rating	2.2	3.7	5.5	7.5	7.5
Standard output during acceleration/deceleration [kW]	2.2	3.7	5.5	7.5	7.5
Actual acceleration/deceleration output (Note 2) [kW]	2.64	4.44	6.6	9	9
Base rotation speed [r/min]	1500	1500	1500	1500	1500
Maximum rotation speed [r/min]	10000	10000	8000	8000	12000
Continuous rated torque [N·m]	9.5	14.0	23.6	35.0	35.0
Inertia [kg·m ²]	0.007	0.009	0.015	0.025	0.025
Degree of protection	IP44	IP44	IP44	IP44	IP44
Outline dimension drawing (flange type)	174 SQ.	174 SQ.	174 SQ.	204 SQ.	204 SQ.
	300	330	425	440	440
Flange fitting diameter [mm]	ø150	ø150	ø150	ø180	ø180
Shaft diameter [mm]	ø28	ø28	ø28	ø32	ø32
Mass [kg]	25	30	49	60	60

Motor type	SJ-4-V11-18T	SJ-4-V18.5-14T	SJ-4-V22-18ZT	SJ-4-V22-15T	SJ-4-V26-08ZT
Compatible drive unit	MDS-EH-SP-80 MDS-EMH-SPV3-	100	160	160	160
Output	11	18.5	15	22	26
Short-time rating	11	18.5	15	22	26
Continuous rating	11	18.5	15	22	26
Standard output during acceleration/deceleration [kW]	11	18.5	15	22	26
Actual acceleration/deceleration output (Note 2) [kW]	13.2	22.2	18	26.4	31.2
Base rotation speed [r/min]	6000	6000	1500	6000	10000
Maximum rotation speed [r/min]	6000	6000	8000	6000	10000
Continuous rated torque [N·m]	47.7	95.5	70.0	118	140
Inertia [kg·m ²]	0.03	0.06	0.06	0.10	0.10
Degree of protection	IP44	IP44	IP44	IP44	IP44
Outline dimension drawing (flange type)	204 SQ.	250 SQ.	250 SQ.	250 SQ.	250 SQ.
	490	469.5	469.5	539.5	585.5
Flange fitting diameter [mm]	ø180	ø230	ø230	ø230	ø230
Shaft diameter [mm]	ø48	ø48	ø48	ø55	ø48
Mass [kg]	70	110	110	135	155

(Note 1) Only the combination designated in this manual can be used for the motor and drive unit. Always use the designated combination.
 (Note 2) Actual acceleration/deceleration output is 1.2-fold of "Standard output during acceleration/deceleration" or "Short time rated output".
 (Note 3) The rated output is guaranteed at the rated input voltage (380 to 440VAC 50Hz / 380 to 480VAC 60Hz) to the power supply unit.
 If the input voltage fluctuates and drops below 380VAC, the rated output may not be attained.
 (Note 4) IP code classifies the degree of protection of the motor body. It does not apply to the other electronic parts such as the cooling fan and the encoder.

SPINDLE MOTOR/BUILT-IN SPINDLE MOTOR/TOOL SPINDLE MOTOR 400V

SERVO MOTOR/LINEAR SERVO MOTOR 400V

■SJ-4-V Series (Normal)

Motor type		SJ-4-V37-04ZT	SJ-4-V45-02T	SJ-4-V55-03T
Compatible drive unit	MDS-EH-SP- MDS-EMH-SPV3	200	320	320
Output				
Standard output during acceleration/deceleration [kW]		37	45	55
Actual acceleration/deceleration output (Note 2) [kW]		44.4	54	66
Base rotation speed [r/min]		1150	1500	1150
Maximum rotation speed [r/min]		6000	4500	3450
Continuous rated torque [N·m]		249	236	374
Inertia [kg·m ²]		0.34	0.34	0.85
Degree of protection		IP44	IP44	IP44
Outline dimension drawing (flange type)				
Flange fitting diameter [mm]		ø300	ø300	ø450
Shaft diameter [mm]		ø60	ø60	ø75
Mass [kg]		300	300	450

■SJ-4-V Series (Wide range constant output)

Motor type		SJ-4-V15-20T	SJ-4-V22-16T
Compatible drive unit	MDS-EH-SP- MDS-EMH-SPV3	100 10040, 10060	160
Output			
Standard output during acceleration/deceleration [kW]		9	15
Actual acceleration/deceleration output (Note 2) [kW]		10.8	18
Base rotation speed [r/min]			750
Maximum rotation speed [r/min]			6000
Continuous rated torque [N·m]		95.5	140
Inertia [kg·m ²]		0.06	0.08
Degree of protection		IP44	IP44
Outline dimension drawing (flange type)			
Flange fitting diameter [mm]		ø230	ø230
Shaft diameter [mm]		ø48	ø55
Mass [kg]		110	135

(Note 1) Only the combination designated in this manual can be used for the motor and drive unit. Always use the designated combination.
 (Note 2) Actual acceleration/deceleration output is 1.2-fold of "Standard output during acceleration/deceleration" or "Short time rated output".
 (Note 3) The rated output is guaranteed at the rated input voltage (380 to 440VAC 50Hz / 380 to 480VAC 60Hz) to the power supply unit.
 If the input voltage fluctuates and drops below 380VAC, the rated output may not be attained.
 (Note 4) IP code classifies the degree of protection of the motor body. It does not apply to the other electronic parts such as the cooling fan and the encoder.

BUILT-IN SPINDLE MOTOR 400V

■SJ-4BG Series

Motor type (Note 1)		SJ-4BG160D/150-01	SJ-4BG180F/150-01	
Compatible drive unit	MDS-EH-SP-	80	160	
Output				
Standard output during acceleration/deceleration [kW]		9.0	15	18.5
Actual acceleration/deceleration output (Note 3) [kW]		10.8	18	22.2
Continuous base rotation speed [r/min]		1500	900	1500
Maximum rotation speed [r/min]		15000	2500	15000
Continuous rated torque [N·m]		23.6	79.6	47.7
Rotor inertia [kg·m ²]		0.0070	0.023	
Outline dimension drawing				
Mass	Stator [kg] Rotor [kg]	11 4.2	27 10	

Motor type (Note 1)		SJ-4BG300C/080-02	
Compatible drive unit	MDS-EH-SP-	100	
Output			
Standard output during acceleration/deceleration [kW]		15	22
Actual acceleration/deceleration output (Note 3) [kW]		18	26.4
Continuous base rotation speed [r/min]		450	1100
Maximum rotation speed [r/min]		1500	8000
Continuous rated torque [N·m]		233	130
Rotor inertia [kg·m ²]		0.21	
Outline dimension drawing			
Mass	Stator [kg] Rotor [kg]	48 28	

(Note 1) Please contact your Mitsubishi Electric dealer for the special products not listed above.
 (Note 2) Only the combination designated in this manual can be used for the motor and drive unit. Always use the designated combination.
 (Note 3) Actual acceleration/deceleration output is 1.2-fold of "Standard output during acceleration/deceleration" or "Short time rated output".

■SJ-4BGS Series (Normal)

Motor type (Note 1)		SJ-4BGS160B/300-01		SJ-4BGS210B/120-01	
Compatible drive unit	MDS-EH-SP-	600		160	
Output Acceleration/Deceleration %ED rating Short-time rating Continuous rating	<input type="checkbox"/>				
	<input type="checkbox"/>	70		30	
Standard output during acceleration/deceleration [kW]		70		30	
Actual acceleration/deceleration output (Note 3) [kW]		84		36	
Continuous base rotation speed [r/min]		17500		2300	
Maximum rotation speed [r/min]		30000		5000	
Continuous rated torque [N·m]		35.5		91.3	
Rotor inertia [kg·m ²]		0.0043		0.020	
Outline dimension drawing [mm]					
		14		18	
Mass	Stator [kg]	14		18	
	Rotor [kg]	2.2		6.8	

Motor type (Note 1)		SJ-4BGS240B/120-01	
Compatible drive unit	MDS-EH-SP-	320	
Output %ED rating Continuous rating	<input type="checkbox"/>		
	<input type="checkbox"/>	37	
Standard output during acceleration/deceleration [kW]		37	
Actual acceleration/deceleration output (Note 3) [kW]		44.4	
Continuous base rotation speed [r/min]		1600	
Maximum rotation speed [r/min]		4000	
Continuous rated torque [N·m]		161	
Rotor inertia [kg·m ²]		0.054	
Outline dimension drawing [mm]			
		28	
Mass	Stator [kg]	28	
	Rotor [kg]	13	

(Note 1) Please contact your Mitsubishi Electric dealer for the special products not listed above.
 (Note 2) Only the combination designated in this manual can be used for the motor and drive unit. Always use the designated combination.
 (Note 3) Actual acceleration/deceleration output is 1.2-fold of "Standard output during acceleration/deceleration" or "Short time rated output".
 (Note 4) SJ-4BGS160B/300-01 is without rotor sleeve, and SJ-4BGS210B/120-01 and SJ-4BGS240B/120-01 are with rotor sleeves.

TOOL SPINDLE MOTOR 400V

■HG-JR Series

Motor type		HG-JR734	HG-JR1534
Compatible drive unit	1-axis type MDS-EH-SP-	20	40
Output Rated torque Max. torque	<input type="checkbox"/>		
	<input type="checkbox"/>		
Rated output [kW]		0.75	1.5
Max. rotation speed [r/min]		8000	
Motor inertia [$\times 10^{-4}$ kg·m ²]		2.09	3.79
Degree of protection (The shaft-through portion is excluded.)		IP67	
Outline dimension drawing [mm]			
		ø80	
Flange fitting diameter [mm]		ø80	
Shaft diameter [mm]		ø16	
Mass [kg]		3.7	5.9

(Note) Only the combination designated in this manual can be used for the motor and drive unit. Always use the designated combination.

DRIVE UNIT

■MDS-E Series

1-axis servo drive unit

Drive unit type	MDS-E-V1-20	MDS-E-V1-40	MDS-E-V1-80	MDS-E-V1-160	MDS-E-V1-160W	MDS-E-V1-320	MDS-E-V1-320W
Drive unit category	1-axis servo						
Nominal maximum current (peak) [A]	20	40	80	160	160	320	320
Power input	Rated voltage [V]	270 to 324DC					
	Rated current [A]	7.0	7.0	14	30	35	45
Control power input	Voltage [V]	200 to 240AC Tolerable fluctuation: between +10% and -15%					
	Current [A]	MAX. 0.6					
	Frequency [Hz]	50/60 Tolerable fluctuation: between +5% and -5%					
Control method	Sine wave PWM control method						
Dynamic brakes	Built-in						External (MDS-D-DBU)
Machine end encoder	Compatible						
Degree of protection	IP20 (excluding terminal block)						
Cooling method	Forced air cooling						
Mass [kg]	3.8	3.8	3.8	3.8	4.5	5.8	7.5
Unit outline dimension drawing	A1	A1	A1	A1	B1	C1	D1

2-axis servo drive unit

Drive unit type	MDS-E-V2-20	MDS-E-V2-40	MDS-E-V2-80	MDS-E-V2-160	MDS-E-V2-160W
Drive unit category	2-axis servo				
Nominal maximum current (peak) [A]	20/20	40/40	80/80	160/160	160/160
Power input	Rated voltage [V]	270 to 324DC			
	Rated current [A]	14	14	28	60
Control power input	Voltage [V]	200 to 240AC Tolerable fluctuation: between +10% and -15%			
	Current [A]	MAX. 0.6			
	Frequency [Hz]	50/60 Tolerable fluctuation: between +5% and -5%			
Control method	Sine wave PWM control method				
Dynamic brakes	Built-in				
Machine end encoder	Compatible				
Degree of protection	IP20 (excluding terminal block)				
Cooling method	Forced air cooling				
Mass [kg]	4.5	4.5	4.6	5.2	6.3
Unit outline dimension drawing	A1	A1	A1	B1	C1

3-axis servo drive unit

Drive unit type	MDS-E-V3-20	MDS-E-V3-40	MDS-E-V3-80
Drive unit category	3-axis servo		
Nominal maximum current (peak) [A]	20/20/20	40/40/40	80/80/80
Power input	Rated voltage [V]	270 to 324DC	
	Rated current [A]	21	21
Control power input	Voltage [V]	200 to 240AC Tolerable fluctuation: between +10% and -15%	
	Current [A]	MAX. 0.6	
	Frequency [Hz]	50/60 Tolerable fluctuation: between +5% and -5%	
Control method	Sine wave PWM control method		
Dynamic brakes	Built-in		
Machine end encoder	Compatible		
Degree of protection	IP20 (excluding terminal block)		
Cooling method	Forced air cooling		Natural-cooling
Mass [kg]	4.3		6.2
Unit outline dimension drawing	A1		B2

■MDS-E Series

1-axis spindle drive unit

Drive unit type	MDS-E-SP-20	MDS-E-SP-40	MDS-E-SP-80	MDS-E-SP-160	MDS-E-SP-200	MDS-E-SP-240	MDS-E-SP-320	MDS-E-SP-400	MDS-E-SP-640	
Drive unit category	1-axis spindle									
Nominal maximum current (peak) [A]	20	40	80	160	200	240	320	400	640	
Power input	Rated voltage [V]	270 to 324DC								
	Rated current [A]	7.0	13	20	41	76	95	140	150	210
Control power input	Voltage [V]	200 to 240AC Tolerable fluctuation: between +10% and -15%								
	Current [A]	MAX. 0.6								
	Frequency [Hz]	50/60 Tolerable fluctuation: between +5% and -5%								
Control method	Sine wave PWM control method									
Degree of protection	IP20 (excluding terminal block)									
Cooling method	Forced air cooling									
Mass [kg]	3.8	3.8	3.8	4.5	5.8	7.5	8.5	15.6	18.3	
Unit outline dimension drawing	A1	A1	A1	B1	C1	D1	D2	E1	F1	

2-axis spindle drive unit

Drive unit type	MDS-E-SP2-20	MDS-E-SP2-40	MDS-E-SP2-80	MDS-E-SP2-16080
Drive unit category	2-axis spindle			
Nominal maximum current (peak) [A]	20/20	40/40	80/80	160/80
Power input	Rated voltage [V]	270 to 324DC		
	Rated current [A]	14	26	40
Control power input	Voltage [V]	200 to 240AC Tolerable fluctuation: between +10% and -15%		
	Current [A]	MAX. 0.6		
	Frequency [Hz]	50/60 Tolerable fluctuation: between +5% and -5%		
Control method	Sine wave PWM control method			
Degree of protection	IP20 (excluding terminal block)			
Cooling method	Forced air cooling			
Mass [kg]	4.5	4.5	5.2	5.2
Unit outline dimension drawing	A1	A1	B1	B1

Power supply unit

Power supply unit	MDS-E-CV-37	MDS-E-CV-75	MDS-E-CV-110	MDS-E-CV-185	MDS-E-CV-300	MDS-E-CV-370	MDS-E-CV-450	MDS-E-CV-550
30-minute rated output [kW]	3.7	7.5	11.0	18.5	30.0	37.0	45.0	55.0
Continuous rated output [kW]	2.2	5.5	7.5	15.0	26.0	30.0	37.0	45.0
Power input	Rated voltage [V]	200 to 240AC Tolerable fluctuation: between +10% and -15%						
	Rated current [A]	15	26	35	65	107	121	148
Control power input	Voltage [V]	200 to 240AC Tolerable fluctuation: between +10% and -15%						
	Current [A]	MAX. 0.2						
	Frequency [Hz]	50/60 Tolerable fluctuation: between +5% and -5%						
Regeneration method	Power regeneration method							
Degree of protection	IP20 (excluding terminal block)							
Cooling method	Natural-cooling				Forced air cooling			
Mass [kg]	3.5	3.5	5.6	5.7	10.6	11.2	11.7	25.5
Unit outline dimension drawing	A2	A2	B1	B1	D1	D1	D2	F1

AC reactor

AC reactor model	D-AL-7.5K	D-AL-11K	D-AL-18.5K	D-AL-30K	D-AL-37K	D-AL-45K	D-AL-55K
Compatible power supply unit type	MDS-E-CV-						
Rated capacity [kW]	37, 75	110	185	300	370	450	550
Rated voltage [V]	200 to 240AC Tolerable fluctuation: between +10% and -15%						
Rated current [A]	7.5	11	18.5	30	37	45	55
Rated current [A]	27	40	66	110	133	162	198
Frequency [Hz]	50/60 Tolerable fluctuation: between +5% and -5%						
Mass [kg]	4.2	3.7	5.3	6.1	8.6	9.7	11.5
Unit outline dimension drawing	R1	R1	R2	R2	R3	R3	R4

■MDS-EH Series

1-axis servo drive unit

Drive unit type		MDS-EH-V1-10	MDS-EH-V1-20	MDS-EH-V1-40	MDS-EH-V1-80	MDS-EH-V1-80W	MDS-EH-V1-160	MDS-EH-V1-160W	MDS-EH-V1-200
Drive unit category		1-axis servo							
Nominal maximum current (peak) [A]		10	20	40	80	80	160	160	200
Power input	Rated voltage [V]	513 to 648DC							
	Rated current [A]	0.9	1.6	2.9	6.0	8.0	11.9	16.7	39
Control power input	Voltage [V]	380 to 480AC Tolerable fluctuation: between +10% and -15%							
	Current [A]	MAX. 0.3							
	Frequency [Hz]	50/60 Tolerable fluctuation: between +5% and -5%							
Control method		Sine wave PWM control method							
Dynamic brakes		Built-in						External (MDS-D-DBU)	
Degree of protection		IP20 (excluding terminal block)							
Cooling method		Natural-cooling		Forced air cooling					
Mass [kg]		3.8	3.8	3.8	3.8	4.5	5.8	7.5	15.4
Unit outline dimension drawing		A1	A1	A1	A1	B1	C1	D1	E1

2-axis servo drive unit

Drive unit type		MDS-EH-V2-10	MDS-EH-V2-20	MDS-EH-V2-40	MDS-EH-V2-80	MDS-EH-V2-80W	MDS-EH-V2-160
Drive unit category		2-axis servo					
Nominal maximum current (peak) [A]		10/10	20/20	40/40	80/80	80/80	160/160
Power input	Rated voltage [V]	513 to 648DC					
	Rated current [A]	1.8	3.2	5.8	12	16	23.8
Control power input	Voltage [V]	380 to 480AC Tolerable fluctuation: between +10% and -15%					
	Current [A]	MAX. 0.3					
	Frequency [Hz]	50/60 Tolerable fluctuation: between +5% and -5%					
Control method		Sine wave PWM control method					
Dynamic brakes		Built-in					
Degree of protection		IP20 (excluding terminal block)					
Cooling method		Natural-cooling		Forced air cooling			
Mass [kg]		4.6	4.6	4.6	5.2	6.3	7.2
Unit outline dimension drawing		A1	A1	A1	B1	C1	C1

3-axis servo drive unit

Drive unit type		MDS-EH-V3-40
Drive unit category		3-axis servo
Nominal maximum current (peak) [A]		40/40/40
Power input	Rated voltage [V]	513 to 648DC
	Rated current [A]	8.7
Control power input	Voltage [V]	380 to 480AC Tolerable fluctuation: between +10% and -15%
	Current [A]	MAX. 0.3
	Frequency [Hz]	50/60 Tolerable fluctuation: between +5% and -5%
Control method		Sine wave PWM control method
Dynamic brakes		Built-in
Degree of protection		IP20 (excluding terminal block)
Cooling method		Natural-cooling
Mass [kg]		6.2
Unit outline dimension drawing		B2

1-axis spindle drive unit

Drive unit type		MDS-EH-SP-20	MDS-EH-SP-40	MDS-EH-SP-80	MDS-EH-SP-100	MDS-EH-SP-160	MDS-EH-SP-200	MDS-EH-SP-320	MDS-EH-SP-480	MDS-EH-SP-600
Drive unit category		1-axis spindle								
Nominal maximum current (peak) [A]		20	40	80	100	160	200	320	480	600
Power input	Rated voltage [V]	513 to 648DC								
	Rated current [A]	10	15	21	38	72	82	119	150	200
Control power input	Voltage [V]	380 to 480AC Tolerable fluctuation: between +10% and -15%								
	Current [A]	MAX. 0.3								
	Frequency [Hz]	50/60 Tolerable fluctuation: between +5% and -5%								
Control method		Sine wave PWM control method								
Degree of protection		IP20 (excluding terminal block)								
Cooling method		Forced air cooling								
Mass [kg]		3.8	3.8	4.5	5.8	7.5	15.4	15.4	18.3	20.1
Unit outline dimension drawing		A1	A1	B1	C1	D1	E1	E1	F1	F1

(Note) Rated output capacity and rated speed of the motor used in combination with the drive unit are as indicated when using the power supply voltage and frequency listed. The torque drops when the voltage is less than specified.

■MDS-EH Series

Power supply unit

Power supply unit type		MDS-EH-CV-37	MDS-EH-CV-75	MDS-EH-CV-110	MDS-EH-CV-185	MDS-EH-CV-300	MDS-EH-CV-370	MDS-EH-CV-450	MDS-EH-CV-550	MDS-EH-CV-750
30-minute rated output [kW]		3.7	7.5	11.0	18.5	30.0	37.0	45.0	55.0	75.0
Continuous rated output [kW]		2.2	5.5	7.5	15	26	30	37	45	55
Power input	Rated voltage [V]	380 to 480AC Tolerable fluctuation: between +10% and -15%								
	Rated current [A]	5.2	13	18	35	61	70	85	106	130
Control power input	Voltage [V]	380 to 480AC Tolerable fluctuation: between +10% and -15%								
	Current [A]	MAX. 0.1								
	Frequency [Hz]	50/60 Tolerable fluctuation: between +5% and -5%								
Main circuit method		Converter with power regeneration circuit								
Degree of protection		IP20 (excluding terminal block)								
Cooling method		Forced air cooling								
Mass [kg]		5.7	5.7	6.0	6.0	10.0	10.0	10.0	25.5	25.5
Unit outline dimension drawing		B1	B1	B1	B1	D1	D1	D1	F1	F1

AC reactor

AC reactor model		DH-AL-7.5K	DH-AL-11K	DH-AL-18.5K	DH-AL-30K	DH-AL-37K	DH-AL-45K	DH-AL-55K	DH-AL-75K	
Compatible power supply unit type	MDS-EH-CV-	37, 75	110	185	300	370	450	550	750	
	Rated capacity [kW]	7.5	11	18.5	30	37	45	55	75	
Rated voltage [V]		380 to 480AC Tolerable fluctuation: between +10% and -15%								
Rated current [A]		14	21	37	65	75	85	105	142	
Frequency [Hz]		50/60 Tolerable fluctuation: between +5% and -5%								
Mass [kg]		4.0	3.7	5.3	6.0	8.5	9.8	10.5	13.0	
Unit outline dimension drawing		R1	R1	R2	R2	R3	R3	R5	R6	

Unit Outline Dimension Drawing

Unit [mm]

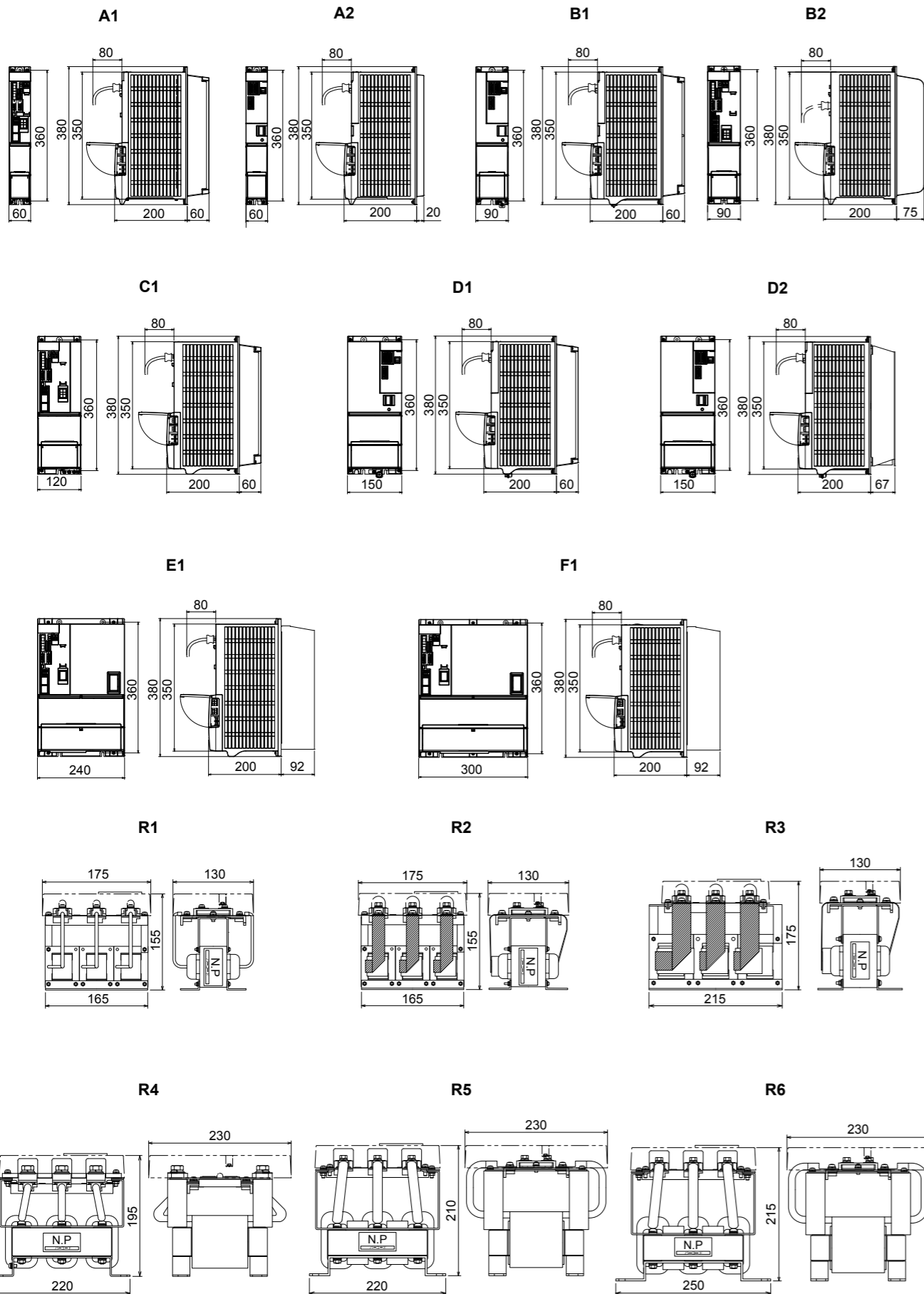

■MDS-EM/EMH Series
Multi-hybrid drive unit

Drive unit type	MDS-EM-SPV3-10040	MDS-EM-SPV3-10080	MDS-EM-SPV3-16040	MDS-EM-SPV3-16040S	MDS-EM-SPV3-16080	MDS-EM-SPV3-20080	MDS-EM-SPV3-200120	MDS-EM-SPV3-320120
Drive unit category	3-axis servo, 1-axis spindle (with converter)							
Nominal maximum current (spindle/servo) [A]	100/40×3	100/80×3	160/40×3	160/40×3	160/80×3	200/80×3	200/120×3	320/120×3
Power input	Rated voltage [V]	200 to 240AC Tolerable fluctuation: between +10% and -15%						
	Rated current [A]	36	38	45	45	48	60	65
Control power input	Voltage [V]	24DC Tolerable fluctuation: between +10% and -10%						
	Current [A]	MAX. 4						
	Frequency [Hz]	50/60 Tolerable fluctuation: between +5% and -5%						
Control method	Sine wave PWM control method							
Regeneration method	Power regeneration method							
Dynamic brakes (servo)	Built-in							
Machine end encoder (servo)	Compatible							
Degree of protection	IP20 (excluding terminal block)							
Cooling method	Forced air cooling							
Mass [kg]	14	14	14	14.5	14	14	14	20.7

Drive unit type	MDS-EMH-SPV3-8040	MDS-EMH-SPV3-10040	MDS-EMH-SPV3-10060
Drive unit category	3-axis servo, 1-axis spindle (with converter)		
Nominal maximum current (spindle/servo) [A]	80/40×3	100/40×3	100/60×3
Power input	Rated voltage [V]	380 to 480AC Tolerable fluctuation: between +10% and -15%	
	Rated current [A]	27	34
Control power input	Voltage [V]	24DC Tolerable fluctuation: between +10% and -10%	
	Current [A]	MAX. 4	
	Frequency [Hz]	50/60 Tolerable fluctuation: between +5% and -5%	
Control method	Sine wave PWM control method		
Regeneration method	Power regeneration method		
Dynamic brakes (servo)	Built-in		
Machine end encoder (servo)	Compatible		
Degree of protection	IP20 (excluding terminal block)		
Cooling method	Forced air cooling		
Mass [kg]	15	15	15

Unit outline dimension drawing

< MDS-EM-SPV3-10040 to 200120 >

< MDS-EMH-SPV3-8040 to 10060 >

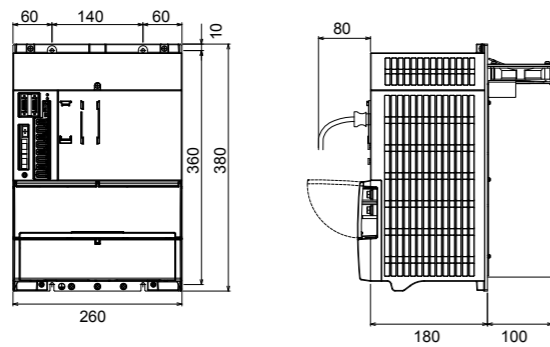

[Unit : mm]

< MDS-EM-SPV3-16040S >

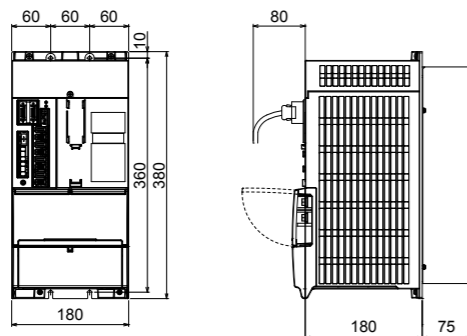

[Unit : mm]

< MDS-EM-SPV3-320120 >

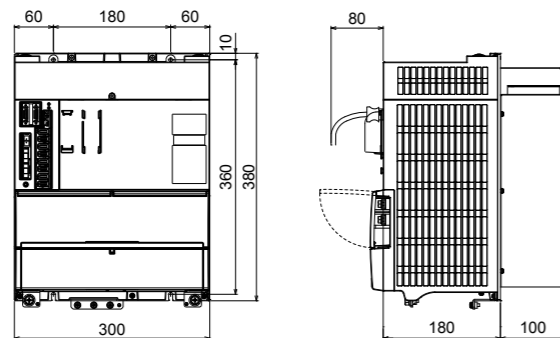

[Unit : mm]

**MDS-EJ/EJH Series
All-in-one compact servo drive unit**

Drive unit type	MDS-EJ-V1-10	MDS-EJ-V1-15	MDS-EJ-V1-30	MDS-EJ-V1-40	MDS-EJ-V1-80	MDS-EJ-V1-100
Drive unit category	1-axis servo (with converter)					
Nominal maximum current (peak) [A]	10	15	30	40	80	100
Power input	Rated voltage [V]	3-phase or single-phase 200 to 240AC Tolerable fluctuation: between +10% and -15%			3-phase 200 to 240AC Tolerable fluctuation: between +10% and -15%	
	Rated current [A]	1.5	2.9	3.8	8.0	10.5
Control power input	Voltage [V]	Single-phase 200 to 240AC Tolerable fluctuation: between +10% and -15%				
	Current [A]	MAX. 0.2				
	Frequency [Hz]	50/60 Tolerable fluctuation: between +5% and -5%				
Control method	Sine wave PWM control method					
Regeneration method	Power regeneration method					
Dynamic brakes	Built-in					
Machine end encoder	Compatible					
Degree of protection	IP20					
Cooling method	Natural cooling			Forced air cooling		
Mass [kg]	0.8	1.0	1.4	2.1	2.1	2.3
Unit outline dimension drawing	J1a	J1b	J2a	J4	J4	J4

Drive unit type	MDS-EJ-V2-30	MDS-EJ-V2-40
Drive unit category	2-axis servo (with converter)	
Nominal maximum current (peak) [A]	30/30	40/40
Power input	Rated voltage [V]	3-phase 200 to 240AC Tolerable fluctuation: between +10% and -15%
	Rated current [A]	7.6
Control power input	Voltage [V]	Single-phase 200 to 240AC Tolerable fluctuation: between +10% and -15%
	Current [A]	MAX. 0.4
	Frequency [Hz]	50/60 Tolerable fluctuation: between +5% and -5%
Control method	Sine wave PWM control method	
Regeneration method	Power regeneration method	
Dynamic brakes	Built-in	
Machine end encoder	Compatible	
Degree of protection	IP20	
Cooling method	Forced air cooling	
Mass [kg]	1.9	4.6
Unit outline dimension drawing	J3	J5b

Drive unit type	MDS-EJH-V1-10	MDS-EJH-V1-15	MDS-EJH-V1-20	MDS-EJH-V1-40
Drive unit category	1-axis servo (with converter)			
Nominal maximum current (peak) [A]	10	15	20	40
Power input	Rated voltage [V]	3-phase 380 to 480AC Tolerable fluctuation: between +10% and -15%		
	Rated current [A]	1.4	2.5	5.1
Control power input	Voltage [V]	Single-phase 380 to 480AC Tolerable fluctuation: between +10% and -15%		
	Current [A]	MAX. 0.1		MAX. 0.2
	Frequency [Hz]	50/60 Tolerable fluctuation: between +5% and -5%		
Control method	Sine wave PWM control method			
Regeneration method	Power regeneration method			
Dynamic brakes	Built-in			
Machine end encoder	Compatible			
Degree of protection	IP20			
Cooling method	Natural cooling		Forced air cooling	
Mass [kg]	1.7	1.7	2.1	3.6
Unit outline dimension drawing	J2b		J4	J5a

All-in-one compact spindle drive unit

Drive unit type	MDS-EJ-SP-20	MDS-EJ-SP-40	MDS-EJ-SP-80	MDS-EJ-SP-100	MDS-EJ-SP-120	MDS-EJ-SP-160
Drive unit category	1-axis spindle (with converter)					
Nominal maximum current (peak) [A]	20	40	80	100	120	160
Power input	Rated voltage [V]	3-phase 200 to 240AC Tolerable fluctuation: between +10% and -15%				
	Rated current [A]	2.6	9.0	10.5	16	26
Control power input	Voltage [V]	Single-phase 200 to 240AC Tolerable fluctuation: between +10% and -15%				
	Current [A]	MAX. 0.2				
	Frequency [Hz]	50/60 Tolerable fluctuation: between +5% and -5%				
Control method	Sine wave PWM control method					
Regeneration method	Power regeneration method					
Degree of protection	IP20			IP20 (excluding terminal block)		
Cooling method	Forced air cooling					
Mass [kg]	1.4	2.1	2.3	4.0	4.0	6.2
Unit outline dimension drawing	J2a	J4	J4	J5a	J5a	J6

Drive unit type	MDS-EJ-SP2-20	
Drive unit category	2-axis servo (with converter)	
Nominal maximum current (peak) [A]	20/20	
Power input	Rated voltage [V]	3-phase 200 to 240AC Tolerable fluctuation: between +10% and -15%
	Rated current [A]	5.2
Control power input	Voltage [V]	Single-phase 200 to 240AC Tolerable fluctuation: between +10% and -15%
	Current [A]	MAX. 0.4
	Frequency [Hz]	50/60 Tolerable fluctuation: between +5% and -5%
Control method	Sine wave PWM control method	
Regeneration method	Power regeneration method	
Degree of protection	IP20 (excluding terminal block)	
Cooling method	Forced air cooling	
Mass [kg]	1.9	
Unit outline dimension drawing	J3	

Unit outline dimension drawing

Unit [mm]

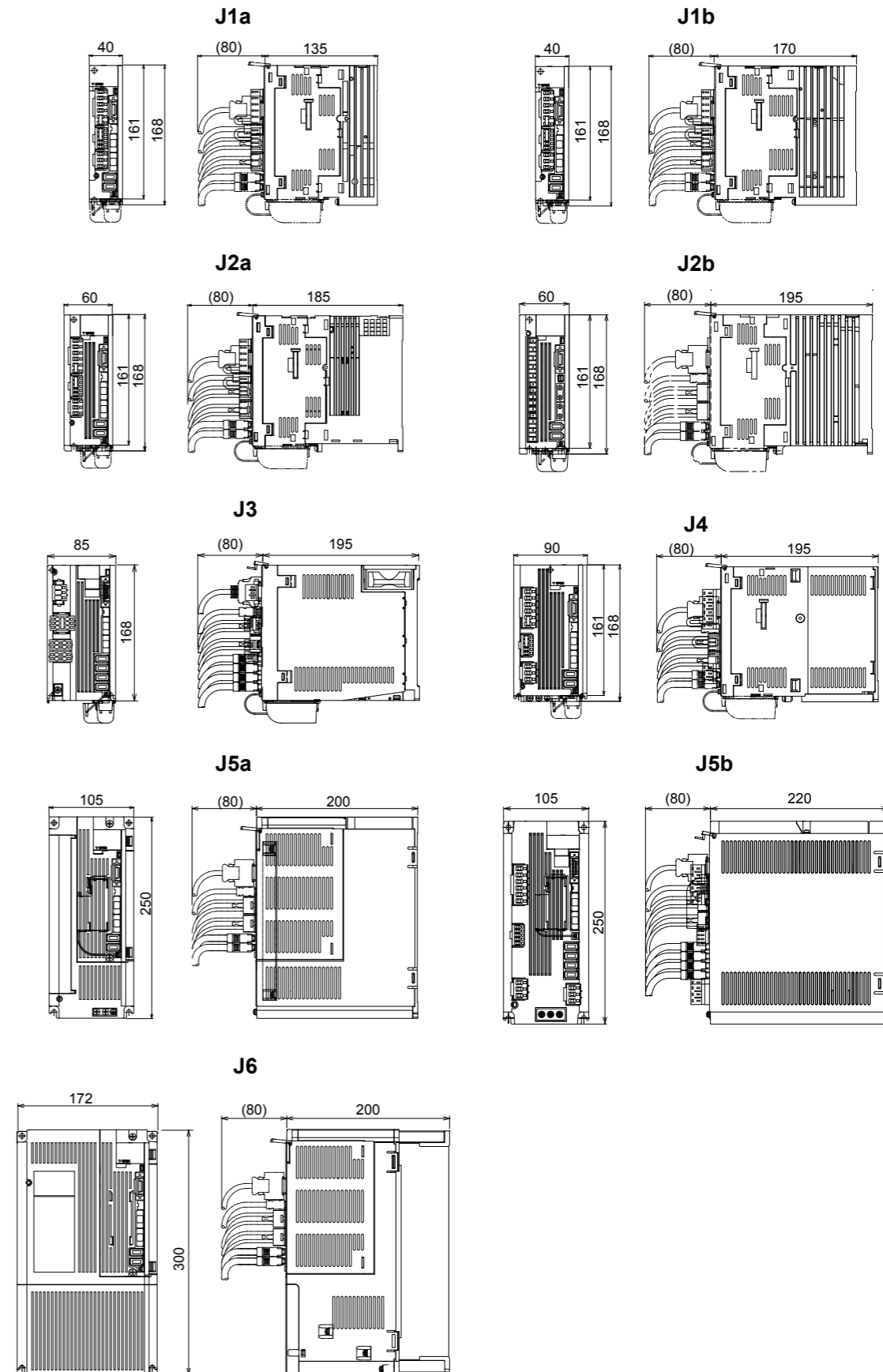

■MDS-EX-CVP Series
Power supply unit

Power supply unit type		MDS-EX-CVP-1100H	MDS-EX-FTB-1100H	MDS-EX-FB-1100H
30-minute rated output [kW]			110	
Continuous rated output [kW]			90	
Power input	Rated voltage [V]	AC380 to 480		
	Rated current [A]		154	
Control power input	Voltage [V]	AC380 to 480		-
	Current [A]	0.3		-
	Frequency [Hz]	50/60 (Allowable range: 47 to 63)		-
Main circuit method		PWM converter	Filter circuit	Fuse circuit
Degree of protection		Open (IP20 (excluding terminal block))		
Cooling method		Forced air cooling	Natural-cooling	
Mass [kg]		36.0	11.5	5.8

AC reactor

AC reactor model		MDS-EX-ALC-1100H	MDS-EX-ALF-1100H
Compatible power supply unit model	MDS-EX-CVP-	1100H	
30-minute rated output [kW]		110	
Continuous rated output [kW]		90	
Rated voltage [V]		AC380 to 480	
Rated current [A]		154	
Frequency [Hz]		47 to 63	
Mass [kg]		90.0	24.5

Unit outline dimension drawing

Unit [mm]

< MDS-EX-CVP-1100H >

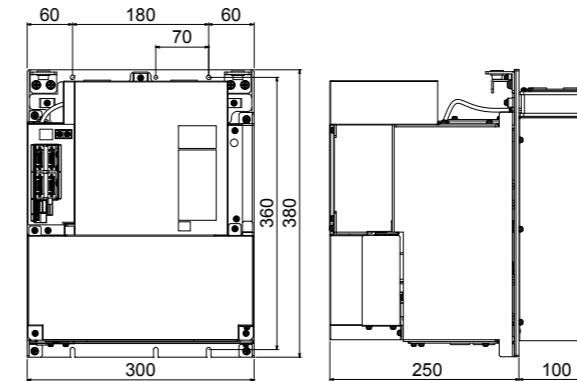

< MDS-EX-FTB-1100H >

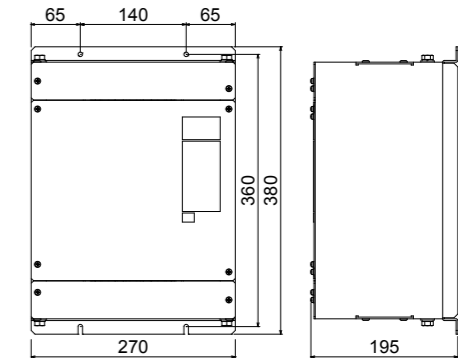

< MDS-EX-FB-1100H >

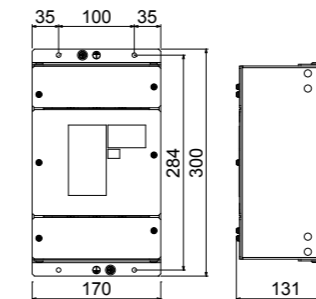

< MDS-EX-ALC-1100H >

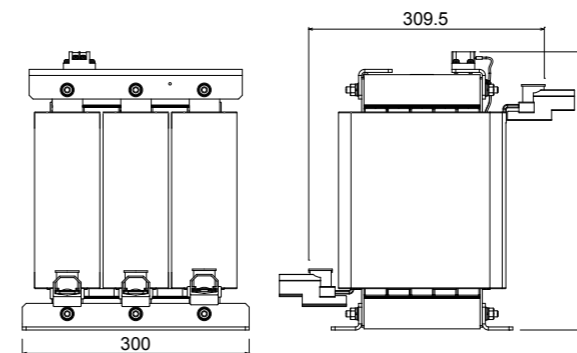

< MDS-EX-ALF-1100H >

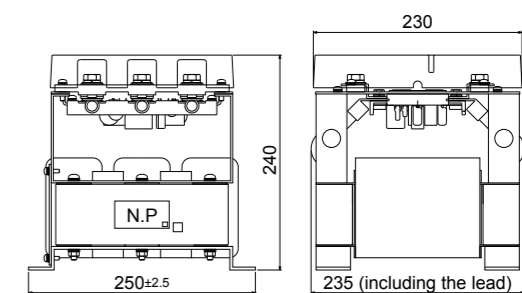

SELECTION OF THE POWER SUPPLY UNIT

For the power supply unit, calculate the spindle motor output and servo motor output each, and select the capacity satisfying the required rated capacity and the maximum momentary output.

■ Calculation of Spindle Output

The spindle rated output and spindle maximum momentary rated output are calculated.

(1) Calculation of spindle rated output

The spindle rated output is calculated according to the following procedure.

(a) Spindle motor rated output

The spindle motor rated output is calculated from the following expression.

$$\text{Spindle motor rated output} = \text{MAX (continuous rated output, short-time rated output} \times \text{short-time rated output coefficient } \alpha, \text{ \%ED rated output} \times \text{\%ED rated output coefficient } \beta)$$

(Note 1) For the spindle motor rated output, use the maximum value of "continuous rated output", "short-time rated output \times short-time rated output coefficient α ", and "%ED rated output \times %ED rated output coefficient β ".

(Note 2) Select the maximum value for the spindle motor with multiple %ED rated output characteristics.

For the spindle short-time rated output coefficient α , use the value in the following table.

List of short-time rated output time and short-time rated output coefficient

Short-time rated output time	Short-time rated output coefficient α	Short-time rated output time	Short-time rated output coefficient α
1 minute	0.2	5 minutes	0.7
2 minutes	0.4	6~7 minutes	0.8
3 minutes	0.5	8~9 minutes	0.9
4 minutes	0.6	10 minutes or more	1.0

(Note 1) Select the set time for the short-time rated output of your spindle motor from the list. E.g.) When the set time for the short-time rated output is "1/12h", it means "5 minutes".

(Note 2) For the motor with coil changeover specification, select the set time for the short-time rated output of the high-speed coil.

For the %ED rated output coefficient β , use the value in the following table.

List of %ED rated output time and %ED rated output coefficient

%ED rated output time	%ED rated output coefficient β
More than or equal to 10% but less than 20%	0.7
More than or equal to 20% but less than 30%	0.9
More than or equal to 30%	1.0

(b) Spindle rated output

The spindle rated output is calculated from the following expression.

Spindle rated output

$$= \text{Spindle motor rated output} \times \text{motor output coefficient } \gamma \text{ of the combined spindle drive unit}$$

For the spindle motor rated output of the above expression, use the value calculated in (a).

For the motor output coefficient of the combined spindle drive unit, use the value corresponding to the used spindle drive unit in the in the following table.

Motor output coefficient list of combined spindle drive unit

< MDS-E Series >

Spindle motor rated output	Combined spindle drive unit MDS-E-SP-								
	20	40	80	160	200	240	320	400	640
to 1.5kW	1.00	1.15	1.25	—	—	—	—	—	—
to 2.2kW	—	1.00	1.15	1.30	—	—	—	—	—
to 3.7kW	—	1.00	1.05	1.20	—	—	—	—	—
to 5.5kW	—	—	1.00	1.10	1.20	—	—	—	—
to 7.5kW	—	—	—	1.00	1.15	1.20	—	—	—
to 11.0kW	—	—	—	1.00	1.05	1.10	1.15	—	—
to 15.0kW	—	—	—	—	1.00	1.05	1.10	—	—
to 18.5kW	—	—	—	—	1.00	1.00	1.05	1.10	—
to 22kW	—	—	—	—	—	1.00	1.00	1.05	1.15
to 26kW	—	—	—	—	—	—	1.00	1.00	1.10
to 30kW	—	—	—	—	—	—	1.00	1.00	1.05
to 37kW	—	—	—	—	—	—	—	1.00	1.05
to 45kW	—	—	—	—	—	—	—	—	1.0
to 55kW	—	—	—	—	—	—	—	—	1.0

< MDS-EH Series >

Spindle motor rated output	Combined spindle drive unit MDS-EH-SP-								
	20	40	80	100	160	200	320	480	600
to 2.2kW	1.00	1.15	1.30	—	—	—	—	—	—
to 3.7kW	1.00	1.05	1.20	—	—	—	—	—	—
to 5.5kW	—	1.00	1.10	1.20	—	—	—	—	—
to 7.5kW	—	—	1.00	1.15	—	—	—	—	—
to 11.0kW	—	—	1.00	1.05	1.15	—	—	—	—
to 15.0kW	—	—	—	1.00	1.10	—	—	—	—
to 18.5kW	—	—	—	1.00	1.05	1.10	—	—	—
to 22kW	—	—	—	—	1.00	1.05	1.15	—	—
to 26kW	—	—	—	—	1.00	1.00	1.10	1.20	—
to 30kW	—	—	—	—	1.00	1.00	1.05	1.15	—
to 37kW	—	—	—	—	—	1.00	1.05	1.10	1.10
to 45kW	—	—	—	—	—	—	1.00	1.05	1.05
to 55kW	—	—	—	—	—	—	1.00	1.00	1.00
to 75kW	—	—	—	—	—	—	—	1.00	1.00

POINT

[1] When the spindle motor applies to the wide range constant output specification or the high-torque specification, the spindle rated output may become large.

[2] The spindle rated output is calculated from the motor output coefficient of the spindle drive unit used in combination with the spindle motor.

(2) Calculation of spindle maximum momentary output

The spindle maximum momentary output is calculated from the following expression.

Spindle maximum momentary output
=MAX (short-time rated output × 1.2, output at acceleration/deceleration × 1.2,%ED rated output×1.2)

(Note) For the spindle rated output, use the largest one among "short-time rated output × 1.2" ,"output at acceleration/ deceleration × 1.2" and "%ED rated output×1.2".

■Calculation of Servo Motor Output

(1) Selection with rated output

(2) Selection with maximum momentary output

For the rated output and maximum momentary output of the servo motor, use the value corresponding to the servo motor in the following table.

Data for servo motor output selection

< 200V series >

Motor HG	46	56	96
Rated output (kW)	0.2	0.4	0.75
Maximum momentary output (kW)	0.85	1.7	3.2

Motor HG	75	105	54	104	154	154 (V3-40)	224	204	354
Rated output (kW)	0.75	1.0	0.5	1.0	1.5	1.5	2.2	2.0	3.5
Maximum momentary output (kW)	2.2	3.5	2.3	5.0	9.0	5.4	12.3	8.0	18.0

Motor HG	123	223	303	453	603	702	703	903	1103	142	302
Rated output (kW)	1.2	2.2	3.0	4.5	6.0	7.0	7.0	9.0	11.0	1.4	3.0
Maximum momentary output (kW)	3.2	6.3	12.0	22.0	26.9	21.2	27.0	41.0	50.0	3.2	6.3

< 400V series >

Motor HG-H	75	105	54	104	154	224	204	354	453	703	903	1502
Rated output (kW)	0.75	1.0	0.5	1.0	1.5	2.2	2.0	3.5	4.5	7.0	9.0	15.0
Maximum momentary output (kW)	2.2	3.5	2.3	5.0	9.0	13.1	8.0	18.0	22.0	27.0	41.0	59.0

Motor HQ-H	903	1103
Rated output (kW)	9.0	11.0
Maximum momentary output (kW)	31.0	47.0

(Note) The maximum momentary output in this table is reference data for selecting the power supply unit and is not data which guarantees the maximum output.

■Selection of the Power Supply Unit

Select the power supply unit from the total sum of the rate output and the maximum momentary output.

(1) Calculation of required rated output

Power supply unit rated capacity > Σ (Spindle rated output) + 0.3 Σ (Servo motor rated output)

Substitute the output calculated from (1) of "Calculation of spindle output"and (1) of "Calculation of servo motor output" to the above expression, and calculate the total sum of the spindle rated output and servo motor rated output. According to this, select the power supply unit satisfying the rated capacity from the following table.

(2) Calculation of required maximum momentary output

Maximum momentary rated capacity of power supply unit ≥
Σ (Spindle maximum momentary output) + Σ (Maximum momentary output of servomotor accelerating/ decelerating simultaneously + Maximum momentary output of direct drive motor accelerating/ decelerating simultaneously)

Substitute the output calculated from (2) of "Calculation of spindle output"and (2) of "Calculation of servo motor output" to the above expression, and calculate the total sum of the "spindle maximum momentary output" and "output of servo motor accelerating/decelerating simultaneously". According to this, select the power supply unit satisfying the maximum momentary rated capacity from the following table.

(3) Selection of power supply unit

Select the power supply unit of which the capacity is larger than that selected in the item (1) and (2).

Power supply unit rated capacity and maximum momentary rated capacity

< MDS-E Series >

Unit	MDS-E-CV-	37	75	110	185	300	370	450	550
Rated capacity (kW)		4.2	8	11.5	19	31	38	46	56
Maximum momentary rated capacity (kW)		16	23	39	60	92	101	125	175

< MDS-EH Series >

Unit	MDS-EH-CV-	37	75	110	185	300	370	450	550	750
Rated capacity (kW)		4.2	8	11.5	19	31	38	46	56	76
Maximum momentary rated capacity (kW)		16	23	39	60	92	101	125	175	180

< MDS-EX-CVP Series >

Unit	MDS-EX-CVP-	1100H
Rated capacity (kW)		90
Maximum momentary rated capacity (kW)		220



- When reducing the time constant replacing the conventional motor with the HG or HG-H Series motor, the power supply capacity may rise because the motor maximum momentary output increases more than the conventional motor. Therefore, make sure to check the selection with maximum momentary rated capacity.
- When the large capacity drive unit (MDS-E-SP-400/640, MDS-EH-SP-200/320/480/600, MDS-EH-V1-200) is connected to the power supply unit, always install the drive unit proximally in the left side of the power supply unit and connect PN terminal with the dedicated DC connection bar.
- When using two large capacity drive units or more, the power supply unit is required for each drive unit.
- For details of selection of MDS-EX-CVP Series, refer to "MDS-EX-CVP Series Specifications and Instruction Manual"(IB-1501587(ENG)).

■ Required Capacity of Power Supply

For the power supply capacity, calculate the required spindle rated output and servo motor rated output each, and select the power supply capacity satisfying them.

(1) Spindle rate output required for power supply

The spindle rate output required for power supply is calculated from the following expression.

Spindle rate output required for power supply =
MAX (Spindle motor continuous rated output, Spindle motor output at accelerating/decelerating,
Spindle motor short-time output) × motor output coefficient γ of combined spindle drive unit

(Note) For the spindle rate output required for the power supply, multiply the largest one of "spindle motor continuous rate output", "spindle motor output at acceleration/deceleration" and "spindle motor short-time output" by the motor output coefficient γ of the combined spindle drive unit.

For the motor output coefficient of the combined spindle drive unit, use the value corresponding to the used spindle drive unit in "Motor output coefficient list of combined spindle drive unit " on (1)-(b) of "Calculation of spindle output"

(2) Servo motor rate output required for power supply

For the servo motor rate output required for power supply, use the value calculated in (1) of "Calculation of servo motor output"

(3) Calculation of rate output required for power supply

Rated capacity required for power supply =
 Σ **(Spindle rate output required for power supply) + 0.3 Σ (servo motor rate output required for power supply)**

Substitute the output calculated from the item (1) and (2) to the above expression, and calculate the rated capacity required for the power supply.

(4) Calculation of required power supply

Power supply capacity (kVA) = Σ {(Required rated capacity calculated in the item (3) (kW) / Capacity of selected power supply unit (kW)} × Power supply capacity base value (kVA)

The power supply capacity base value corresponding to the capacity of the selected power supply unit is as the following table.

< MDS-E Series >

Unit	MDS-E-CV-	37	75	110	185	300	370	450	550
Power supply capacity base value (kVA)		5.3	11.0	16.0	27.0	43.0	53.0	64.0	78.0

< MDS-EH Series >

Unit	MDS-EH-CV-	37	75	110	185	300	370	450	550	750
Power supply capacity base value (kVA)		5.3	11.0	16.0	27.0	43.0	53.0	64.0	78.0	107.0

< MDS-EX-CVP Series >

Unit	MDS-EX-CVP-	1100H
Power supply capacity base value (kVA)		130

■ Example for Power Supply Unit and Power Supply Facility Capacity

< MDS-E Series >

(Example 1)

Axis name	Motor	Drive unit	Rated output	Maximum momentary output
X-axis	HG354	(MDS-E-V2-160)	3.5kW	18kW
Y-axis	HG354	(MDS-E-V2-160)	3.5kW	18kW
Z-axis	HG354	(MDS-E-V1-160)	3.5kW	18kW
Spindle	Spindle motor 22kW	MDS-E-SP-320 (Output coefficient 1.0)	22kW	26.4kW
Total			0.3×(3.5×3) +22 =25.15kW <31kW (E-CV-300)	(18×3) +26.4 =80.4kW <92kW (E-CV-300)

The power supply unit satisfying the total of the rate output and the maximum momentary output is MDS-E-CV-300.
 Required power supply capacity (kVA) = (25.15 / 30) × 43 = 36.0 (kVA)

(Example 2)

Axis name	Motor	Drive unit	Rated output	Maximum momentary output
X1-axis	HG453	(MDS-E-V2-160)	4.5kW	22kW
X2-axis	HG453	(MDS-E-V2-160)	4.5kW	22kW
Y-axis	HG354	(MDS-E-V2-160)	3.5kW	18kW
Z-axis	HG354	(MDS-E-V2-160)	3.5kW	18kW
Spindle	Spindle motor 15kW	MDS-E-SP-200 (Output coefficient 1.0)	15kW	18kW
Total			0.3×(4.5×2+3.5×2) +15 =19.8kW <31kW (E-CV-300)	22×2+18×2+18 =98.0kW <101kW (E-CV-370)

The power supply unit satisfying the total of the rate output and the maximum momentary output is MDS-E-CV-370.
 Required power supply capacity (kVA) = (19.8 / 37) × 53 = 28.4 (kVA)

(Example 3)

Axis name	Motor	Drive unit	Rated output	Maximum momentary output
X-axis	HG354	MDS-E-V1-160	3.5kW	18kW
Y-axis	HG204	MDS-E-V2-80	2.0kW	8kW
Z-axis	HG204	MDS-E-V2-80	2.0kW	8kW
Spindle	Spindle motor 15kW (High-torque motor)	MDS-E-SP-320 (Output coefficient 1.1)	16.5kW	18kW
Total			0.3×(3.5+2.0×2) +16.5 =18.75kW <19kW (E-CV-185)	18+8×2+18 =52kW <60kW (E-CV-185)

The power supply unit satisfying the total of the rate output and the maximum momentary output is MDS-E-CV-185.
 Required power supply capacity (kVA) = (18.75 / 18.5) × 27 = 27.4 (kVA)

< MDS-EH Series >
(Example 1)

Axis name	Motor	Drive unit	Rated output	Maximum momentary output
X-axis	HG-H354	(MDS-EH-V2-80)	3.5kW	18kW
Y-axis	HG-H354	(MDS-EH-V2-80)	3.5kW	18kW
Z-axis	HG-H354	(MDS-EH-V1-80)	3.5kW	18kW
Spindle	Spindle motor 22kW	MDS-EH-SP-160 (Output 22kW)	22kW	26.4kW
Total			0.3×(3.5×3)+22 =25.15kW <31kW (EH-CV-300)	(18×3)+26.4 =80.4kW <92kW (EH-CV-300)

The power supply unit satisfying the total of the rate output and the maximum momentary output is MDS-EH-CV-300.
Required power supply capacity (kVA) = (25.15 / 30) × 43 = 36.0 (kVA)

(Example 2)

Axis name	Motor	Drive unit	Rated output	Maximum momentary output
X1-axis	HG-H453	(MDS-EH-V2-80)	4.5kW	22kW
X2-axis	HG-H453	(MDS-EH-V2-80)	4.5kW	22kW
Y-axis	HG-H354	(MDS-EH-V2-80)	3.5kW	18kW
Z-axis	HG-H354	(MDS-EH-V2-80)	3.5kW	18kW
Spindle	Spindle motor 15kW	MDS-EH-SP-100 (Output coefficient 1.0)	15kW	18kW
Total			0.3×(4.5×2+3.5×2)+15 =19.8kW <31kW (EH-CV-300)	22×2+18×2+18 =98.0kW <101kW (EH-CV-370)

The power supply unit satisfying the total of the rate output and the maximum momentary output is MDS-EH-CV-370.
Required power supply capacity (kVA) = (19.8 / 37) × 53 = 28.4 (kVA)

(Example 3)

Axis name	Motor	Drive unit	Rated output	Maximum momentary output
X-axis	HG-H354	MDS-EH-V1-160	3.5kW	18kW
Y-axis	HG-H204	MDS-EH-V2-80	2.0kW	8kW
Z-axis	HG-H204	MDS-EH-V2-80	2.0kW	8kW
Spindle	Spindle motor 15kW (High-torque motor)	MDS-EH-SP-320 (Output coefficient 1.1)	16.5kW	18kW
Total			0.3×(3.5+2.0×2)+16.5 =18.75kW <19kW (EH-CV-185)	18+8×2+18 =52kW <60kW (EH-CV-185)

The power supply unit satisfying the total of the rate output and the maximum momentary output is MDS-EH-CV-185.
Required power supply capacity (kVA) = (18.75 / 18.5) × 27 = 27.4 (kVA)

■ Selection of Regenerative Resistor for Power Backup Unit (R-UNIT-6,7) and Capacitor Unit for Power Backup Unit (MDS-D/DH-CU)

When using the retraction function at power failure with MDS-D/DH-PFU, select to satisfy the stop operation for the regenerative resistor and the continuous rated output of the spindle motor for the capacitor unit.

(1) Selection of regenerative resistor for power backup unit

When using the retraction function at power failure, a resistor unit is required to make the spindle deceleration and stop after the retraction is completed.



- When not using a resistor unit, control to coast the spindle motor after the retraction operation is completed.
- Only the designated combination can be used for the power backup unit and the regenerative resistor.

(2) Selection of capacitor unit for power backup unit

When using the retraction function at power failure, the required number of capacitor units is decided by the continuous rated output [kW] of the spindle motor. Select according to the following specifications.

List of spindle continuous rated output and number of capacitor unit

Spindle continuous rated output	Number of capacitor unit
3.7kW or less	1
5.5kW or less	2
7.5kW or less	3
11kW or less	4
15kW or less	5
22kW or less	6

SELECTION OF THE ADDITIONAL AXIS DRIVE UNIT

When selecting an additional axis drive unit to be connected to TE2 [L+,L-] (Converter voltage input terminal) of MDS-EM/EMH-SPV3, calculate the spindle motor output and servo motor output each, and select the capacity so that the total sum should not exceed the rated capacity and the maximum momentary output of MDS-EM/EMH-SPV3.

The additional axis drive unit is spindle/servo drive unit which is operated by using the built-in power supply section of MDS-EM/EMH-SPV3.

Connectable drive units are determined by the rated capacity of MDS-EM/EMH-SPV3.
The following capacities are available.

- Spindle drive unit: MDS-E-SP-20/40/80/160
: MDS-EH-SP-20/40/80
Servo drive unit : MDS-E-Vx-20/40/80
: MDS-EH-Vx-10/20/40/80

MDS-EM-SPV3-16040S

- Spindle drive unit: MDS-E-SP-20/40
Servo drive unit : MDS-E-Vx-20/40

MDS-EM-SPV3-320120

- Spindle drive unit: MDS-E-SP-20/40/80
Servo drive unit : MDS-E-Vx-20/40/80

■ Calculation of Spindle Output

The spindle rated output and spindle maximum momentary rated output are calculated.

(1) Calculation of spindle rated output

The spindle rated output is calculated according to the following procedure.

(a) Spindle motor rated output

The spindle motor rated output is calculated from the following expression.

Spindle motor rated output =
MAX (continuous rated output, short-time rated output × short-time rated output coefficient α,
%ED rated output × %ED rated output coefficient β)

(Note 1) For the spindle motor rated output, use the maximum value of "continuous rated output", "short-time rated output × short-time rated output coefficient α", and "%ED rated output × %ED rated output coefficient β".

(Note 2) Select the maximum value for the spindle motor with multiple %ED rated output characteristics.

For the spindle short-time rated output coefficient α, use the value in the following table.

List of short-time rated output time and short-time rated output coefficient

Short-time rated output time	Short-time rated output coefficient α	Short-time rated output time	Short-time rated output coefficient α
1 minute	0.2	5 minutes	0.7
2 minutes	0.4	6 to 7 minutes	0.8
3 minutes	0.5	8 to 9 minutes	0.9
4 minutes	0.6	10 minutes or more	1.0

(Note 1) Select the set time for the short-time rated output of your spindle motor from the list.
E.g.) When the set time for the short-time rated output is "1/12h", it means "5 minutes".

(Note 2) For the motor with coil changeover specification, select the set time for the short-time rated output of the high-speed coil.

For the %ED rated output coefficient β, use the value in the following table.

List of %ED rated output time and %ED rated output coefficient

%ED rated output time	%ED rated output coefficient β
More than or equal to 10% but less than 20%	0.7
More than or equal to 20% but less than 30%	0.9
More than or equal to 30%	1.0

(b) Spindle rated output

The spindle rated output is calculated from the following expression.

$$\text{Spindle rated output} = (\text{Spindle motor rated output} \times \text{motor output coefficient } \gamma \text{ of the multi-hybrid drive unit}) + (\text{Spindle motor rated output} \times \text{motor output coefficient } \gamma \text{ of the additional axis (spindle) drive unit})$$

For the spindle motor rated output of the above expression, use the value calculated in (a).
For the motor output coefficient of the combined spindle drive unit, use the value corresponding to the used spindle drive unit in the following table.

Motor output coefficient list of multi-hybrid drive unit

< MDS Series >

Spindle motor rated output	Multi-hybrid drive unit MDS-EM-SPV3-			
	10040/10080	16040/16040S/16080	20080/200120	320120
to 1.5kW	1.30	-	-	-
to 2.2kW	1.20	1.30	-	-
to 3.7kW	1.10	1.20	-	-
to 5.5kW	1.10	1.10	1.20	-
to 7.5kW	1.10	1.00	1.15	-
to 11.0kW	-	1.00	1.05	1.15
to 15.0kW	-	-	1.00	1.10
to 18.5kW	-	-	1.00	1.05
to 22.0kW	-	-	-	1.00
to 26.0kW	-	-	-	1.00
to 30.0kW	-	-	-	1.00

< MDS-EMH Series >

Spindle motor rated output	Multi-hybrid drive unit MDS-EMH-SPV3-	
	8040	10040/10060
to 2.2kW	1.30	-
to 3.7kW	1.20	-
to 5.5kW	1.10	1.20
to 7.5kW	1.00	1.15
to 11.0kW	1.00	1.05
to 15.0kW	-	1.00
to 18.5kW	-	1.00

Motor output coefficient list of additional axis (spindle) drive unit

< MDS-E Series >

Spindle motor rated output	Additional axis (spindle) drive unit MDS-E-SP-			
	20	40	80	160
to 1.5kW	1.00	1.15	1.25	-
to 2.2kW	-	1.00	1.15	1.30
to 3.7kW	-	1.00	1.05	1.20
to 5.5kW	-	-	1.00	1.10
to 7.5kW	-	-	-	1.00

< MDS-EH Series >

Spindle motor rated output	Additional axis (spindle) drive unit MDS-EH-SP-		
	20	40	80
to 1.5kW	1.00	1.15	1.25
to 2.2kW	-	1.00	1.15
to 3.7kW	-	1.00	1.05
to 5.5kW	-	-	1.00
to 7.5kW	-	-	1.00

POINT

- [1] When the spindle motor applies to the wide range constant output specification or the high-torque specification, the spindle rated output may become large.
- [2] The spindle rated output is calculated from the motor output coefficient of the spindle drive unit used in combination with the spindle motor.

(2) Calculation of spindle maximum momentary output

The spindle maximum momentary output is calculated from the following expression.

$$\text{Spindle maximum momentary output} = \text{MAX}(\text{short-time rated output} \times 1.2, \text{output at acceleration/deceleration} \times 1.2, \%ED \text{ rated output} \times 1.2)$$

(Note) For the spindle rated output, use the largest one among "short-time rated output × 1.2", "output at acceleration/ deceleration × 1.2" and "%ED rated output×1.2".

■ Calculation of Servo Motor Output

(1) Selection with rated output

(2) Selection with maximum momentary output

For the rated output and maximum momentary output of the servo motor, use the value corresponding to the servo motor in the following table.

Data for servo motor output selection

< 200V series >

Motor HG	96
Rated output (kW)	0.75
Maximum momentary output (kW)	3.2

Motor HG	75	105	54	104	154	224	204	354
Rated output (kW)	0.75	1.0	0.5	1.0	1.5	2.2	2.0	3.5
Maximum momentary output (kW)	2.2	3.5	2.3	5.0	9.0	12.3	8.0	15.0

Motor HG	123	223	303	453	702	142	302
Rated output (kW)	1.2	2.2	3.0	4.5	7.0	1.4	3.0
Maximum momentary output (kW)	3.2	6.3	12.0	16.5	21.2	3.2	6.3

< 400V series >

Motor HG-H	54	104	154	204	354	453
Rated output (kW)	0.5	1.0	1.5	2.0	3.5	4.5
Maximum momentary output (kW)	2.3	5.0	9.0	8.0	18.0	22.0

(Note) The maximum momentary output in this table is reference data for selecting the additional axis drive unit connecting to MDS-EM/EMH-SPV3 and is not data which guarantees the maximum output.

■ Selection of the Additional Axis Drive Unit

Select the additional axis drive unit so that the total sum of the rated output and the maximum momentary output of spindle motor / servo motor is less than the rated capacity and maximum momentary rated capacity of MDS-EM/EMH-SPV3.

(1) Calculation of required rated output

$$\text{MDS-EM/EMH-SPV3 rated capacity} > \Sigma (\text{Spindle rated output}) + 0.3 \Sigma (\text{Servo motor rated output})$$

(Note) Calculate the spindle and servo motor rated output including not only the motor connected to the additional axis drive unit but also those connected to MDS-EM/EMH-SPV3.

Substitute the output calculated from (1) of "Calculation of spindle output" and (1) of "Calculation of servo motor output" to the above expression, and calculate the total sum of the spindle rated output and servo motor rated output. According to this, select the unit so that the rated capacity of MDS-EM/EMH-SPV3 is less than the values in the following table.

(2) Calculation of required maximum momentary output

$$\text{Maximum momentary rated capacity of MDS-EM/EMH-SPV3} \geq \Sigma (\text{Spindle maximum momentary output}) + \Sigma (\text{Maximum momentary output of servo motor accelerating/ decelerating simultaneously})$$

(Note) Calculate the spindle and servo motor maximum momentary output including not only the motor connected to the additional axis drive unit but also those connected to MDS-EM/EMH-SPV3.

Substitute the output calculated from (2) of "Calculation of spindle output" and (2) of "Calculation of servo motor output" to the above expression, and calculate the total sum of the "spindle maximum momentary output" and "output of servo motor accelerating/decelerating simultaneously". According to this, select the unit so that the maximum momentary rated capacity of MDS-EM/EMH-SPV3 is less than the values in the following table.

Power supply unit rated capacity and maximum momentary rated capacity

< MDS-EM Series >

Unit	MDS-EM-SPV3-	16040S	10040/10080/16040/16080/20080/200120	320120
Rated capacity (kW)		15	20	37
Maximum momentary rated capacity (kW)		42	70	101

< MDS-EMH Series >

Unit	MDS-EMH-SPV3-	8040/10040/10060
Rated capacity (kW)		22
Maximum momentary rated capacity (kW)		76



When reducing the time constant replacing the conventional motor with the HG or HG-H Series motor, the motor maximum momentary output may increase more than the conventional motor. Therefore, make sure to check the selection with maximum momentary rated capacity.

■ Required Capacity of Power Supply

For the power supply capacity, calculate the required spindle rated output and servo motor rated output each, and select the power supply capacity satisfying them.

(1) Spindle rated output required for power supply

The spindle rated output required for power supply is calculated from the following expression.

$$\text{Spindle rated output required for power supply} = \text{MAX (Spindle motor continuous rated output, Spindle motor output at accelerating/decelerating, Spindle motor short-time output)} \times \text{motor output coefficient } \gamma \text{ of combined spindle drive unit}$$

(Note) For the spindle rated output required for the power supply, multiply the largest one of "spindle motor continuous rated output", "spindle motor output at acceleration/deceleration" and "spindle motor short-time output" by the motor output coefficient γ of the combined spindle drive unit.

For the motor output coefficient of the combined spindle drive unit, use the value corresponding to the used spindle drive unit "Motor output coefficient list of additional axis (spindle) drive unit" on (1)-(b) of "Calculation of spindle output"

(2) Servo motor rated output required for power supply

For the servo motor rated output required for power supply, use the value calculated in (1) of "Calculation of servo motor output"

(3) Calculation of rated output required for power supply

$$\text{Rated capacity required for power supply} = \Sigma (\text{Spindle rated output required for power supply}) + 0.3 \Sigma (\text{servo motor rated output required for power supply})$$

Substitute the output calculated from the item (1) and (2) to the above expression, and calculate the rated capacity required for the power supply.

(4) Calculation of required power supply

$$\text{Power supply capacity (kVA)} = \{(\text{Required rated capacity calculated in the item (3)}(\text{kW}) / \text{Rated capacity of MDS-EM/EMH-SPV3}) \times \text{Power supply capacity base value of MDS-EM/EMH-SPV3}\}$$

The power supply capacity base value of MDS-EM/EMH-SPV3 is as the following table.

< MDS-EM Series >

Unit	MDS-EM-SPV3-	16040S	10040/10080/16040/16080/20080/200120	320120
Power supply capacity base value (kVA)		21	29	54

< MDS-EMH Series >

Unit	MDS-EMH-SPV3-	8040/10040/10060
Power supply capacity base value (kVA)		32

■ Example for Additional Axis Drive Unit and Power Supply Facility Capacity

< MDS-EM Series >
(Example 1)

Axis name	Motor	Drive unit	Rated output	Maximum momentary output
X-axis	HG204	MDS-EM-SPV3-200120	2.0kW	8.0kW
Y-axis	HG204		2.0kW	8.0kW
Z-axis	HG354		3.5kW	15kW
MG-axis	HG104	MDS-E-V1-40 (Additional axis)	1.0kW	5.0kW
Spindle	Spindle motor 15kW	MDS-EM-SPV3-200120	15kW	18kW
Total			0.3×(2.0+2.0+3.5+1.0)+15 =17.55kW <20kW (EM-SPV3)	(8.0+8.0+15+5.0)+18 =54kW <70kW (EM-SPV3)

Required power supply capacity (kVA) = (17.55/20) × 29 = 25.5 (kVA)

(Example 2)

Axis name	Motor	Drive unit	Rated output	Maximum momentary output
X-axis	HG104	MDS-EM-SPV3-10040	1.0kW	5.0kW
Y-axis	HG104		1.0kW	5.0kW
Z-axis	HG104		1.0kW	5.0kW
A-axis	HG75	MDS-E-V3-20 (Additional axis)	0.75kW	2.2kW
B-axis	HG75		0.75kW	2.2kW
C-axis	HG75		0.75kW	2.2kW
Spindle (1)	Spindle motor 7.5kW	MDS-EM-SPV3-10040	7.5kW	9.0kW
Spindle (2)	Spindle motor 3.7kW	MDS-E-SP-80 (Additional axis)	3.7kW	4.44kW
Spindle (3)	Spindle motor 3.7kW		3.7kW	4.44kW
Total			0.3×(1.0×3+0.75×3)+ (7.5+3.7+3.7)=16.5kW <20kW (EM-SPV3)	(5.0×3+2.2×3)+ (9.0+4.44+4.44)=39.5kW <70kW (EM-SPV3)

Required power supply capacity (kVA) = (16.5/20) × 29 = 24.0 (kVA)

< MDS-EMH Series >
(Example 1)

Axis name	Motor	Drive unit	Rated output	Maximum momentary output
X-axis	HG-H204	MDS-EMH-SPV3-10060	2.0kW	8.0kW
Y-axis	HG-H204		2.0kW	8.0kW
Z-axis	HG-H354		3.5kW	15kW
MG-axis	HG-H104	MDS-EH-V1-20 (Additional axis)	1.0kW	5.0kW
Spindle	Spindle motor 15kW	MDS-EMH-SPV3-10060	15kW	18kW
Total			0.3×(2.0+2.0+3.5+1.0)+15 =17.55kW <22kW (EMH-SPV3)	(8.0+8.0+15+5.0)+18 =54kW <76kW (EMH-SPV3)

Required power supply capacity (kVA) = (17.55/22) × 32 = 25.5(kVA)

SERVO OPTIONS

Battery options are required depending on the type of machine end encoder in the full closed loop control system. Check the options to be required referring the following lists.

■ System establishment in the full closed loop control

Full closed loop control for linear axis

Machine side encoder to be used		Encoder signal output	Drive unit input signal	Battery option	Remarks	
Incremental encoder	Rectangular wave signal output	SR74, SR84 (MAGNESCALE)	Rectangular wave signal	Rectangular wave signal	-	
		Various scale	Rectangular wave signal	Rectangular wave signal	-	
	SIN wave signal output	LS187, LS487 (HEIDENHAIN)	SIN wave signal	Rectangular wave signal	-	
		LS187C, LS487C (HEIDENHAIN)	SIN wave signal	Mitsubishi serial signal	(Required) (Note 1)	Distance-coded reference scale (Note 2)
Mitsubishi serial signal output	SR75, SR85 (MAGNESCALE)	Mitsubishi serial signal	Mitsubishi serial signal	-		
	Various scale	SIN wave signal	Mitsubishi serial signal	(Required) (Note 1)	Distance-coded reference scale is also available (Note 2)	
Absolute position encoder	Mitsubishi serial signal output	OSA405ET2AS, OSA676ET2AS (MITSUBISHI ELECTRIC)	Mitsubishi serial signal	Mitsubishi serial signal	Required	Ball screw side encoder
		SR27, SR77, SR87, SR67A (MAGNESCALE)	Mitsubishi serial signal	Mitsubishi serial signal	Not required	
		LIC2197M, LIC2199M (HEIDENHAIN)	Mitsubishi serial signal	Mitsubishi serial signal	Not required	Mitsu03-4
		MC15M (HEIDENHAIN)	Mitsubishi serial signal	Mitsubishi serial signal	Not required	Mitsu03-4
		LC195M, LC495M, LC291M (HEIDENHAIN)	Mitsubishi serial signal	Mitsubishi serial signal	Not required	Mitsu03-4
		AT343, AT543, AT545, ST748, AT1143 (Mitutoyo)	Mitsubishi serial signal	Mitsubishi serial signal	Not required	
		SAM Series, SVAM Series, GAM Series, LAM Series (FAGOR)	Mitsubishi serial signal	Mitsubishi serial signal	Not required	
		RL40N Series (Renishaw)	Mitsubishi serial signal	Mitsubishi serial signal	Not required	
		AMS-ABS-3B Series (Schneeberger)	Mitsubishi serial signal	Mitsubishi serial signal	Not required	
		LMFA Series, LMBA Series (AMO)	Mitsubishi serial signal	Mitsubishi serial signal	Not required	

Full closed loop control for rotary axis

Machine side encoder to be used		Encoder signal output	Output signal	Battery option	Remarks	
Incremental encoder	Rectangular wave signal output	Various scale	Rectangular wave signal	Rectangular wave signal	-	
			SIN wave signal	Mitsubishi serial signal	-	
	SIN wave signal output	ERM280 Series (HEIDENHAIN)	SIN wave signal	Mitsubishi serial signal	(Required) (Note 1)	Distance-coded reference scale is also available (Note 2)
Absolute position encoder	Mitsubishi serial signal output	Various scale	SIN wave signal	Mitsubishi serial signal	(Required) (Note 1)	Distance-coded reference scale is also available (Note 2)
		RU77, RS87 (MAGNESCALE)	Mitsubishi serial signal	Mitsubishi serial signal	Not required	
		RCN2590M, RCN5390M, RCN5590M, RCN8390M (HEIDENHAIN)	Mitsubishi serial signal	Mitsubishi serial signal	Not required	Mitsu03-4
		ROC425M, ROC2390M ECA4000 Series (HEIDENHAIN)	Mitsubishi serial signal	Mitsubishi serial signal	Not required	Mitsu03-4
		RA Series (Renishaw)	Mitsubishi serial signal	Mitsubishi serial signal	Not required	
		HAM Series (FAGOR)	Mitsubishi serial signal	Mitsubishi serial signal	Not required	
	WMFA Series, WMBA Series, WMRA Series (AMO)	Mitsubishi serial signal	Mitsubishi serial signal	Not required		
SIN wave signal output	MPRZ Series (Mitsubishi Heavy Industries Machine Tool)	SIN wave signal	Mitsubishi serial signal	Not required		

(Note 1) When using the distance-coded reference scale, it is recommended to use with distance-coded reference check function. In this case, the battery option is required.

(Note 2) Use the option of M800 Series for the distance-coded reference scale. It cannot be used with the speed command synchronous control.

(Note 3) Connectable scales besides these are also marketed. Contact each scale manufacturer for details. For the specifications of the scale, including the scales shown in this manual, refer to the manuals issued by the manufacturer.

■System establishment in the synchronous control

Position command synchronous control

The synchronous control is all executed in the NC, and the each servo is controlled as an independent axis. Therefore, preparing special options for the synchronous control is not required on the servo side.

Speed command synchronization control

The common position control in two axes is performed by one linear scale. Basically, the multi axis integrated type drive unit (MDS-E/EH-V2/V3) is used, and the feedback signal is divided for two axes inside the drive unit. When the two 1-axis type drive units are used in driving the large capacity servo motor, the linear scale feedback signal must be divided outside.

<Required option in the speed command synchronous control>

Machine side encoder to be used	For MDS-E/EH-V2/V3	For MDS-E/EH-V1x2 units	Remarks
SIN wave signal output scale	MDS-EX-HR-11 (Serial conversion)	Not possible	Including the case that an interface unit of the scale manufacturer is used with SIN wave output scale.
Mitsubishi serial signal output scale	Direct connection	MDS-B-SD (Signal division)	

(Note) The distance-coded reference scale speed command synchronous control and the rectangular wave signal output scale speed command synchronous control are not available.

■Dynamic brake unit (MDS-D-DBU)

Specifications

Type	MDS-D-DBU
Coil specifications	DC24V 160mA
Wire size	5.5mm ² or more (For IV wire)
Compatible drive unit	MDS-E-V1-320W, MDS-EH-V1-160W or larger
Mass	3kg

Outline dimension drawing
MDS-D-DBU

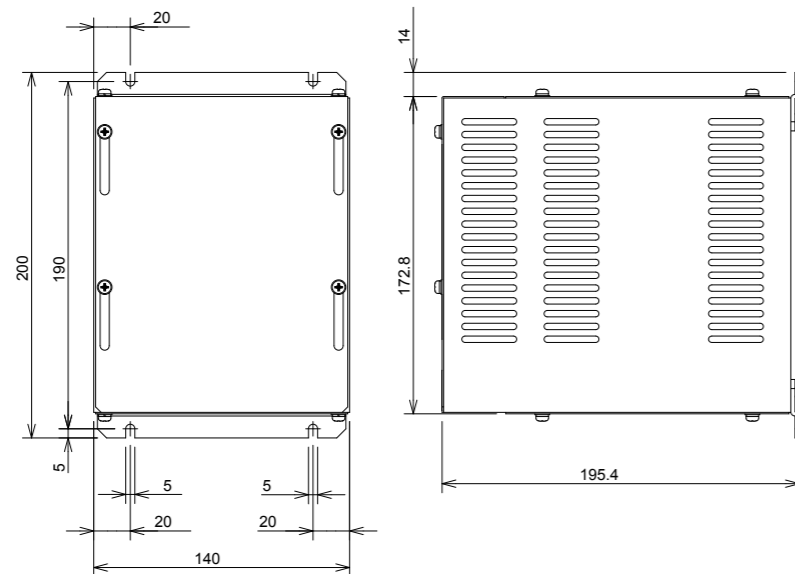

[Unit : mm]

■Battery option

This battery option may be required to establish absolute position system. Select a battery option from the table below depending on the servo system.

Type	MDS-BAT6V1SET	MR-BAT6V1SET	MDSBTBOX-LR2060
Installation type	Drive unit installation	Drive unit installation	Control panel installation
Hazard Class	Not applicable	Not applicable	Not applicable
Number of connectable axes	Up to 3 axes	Up to 3 axes	Up to 8 axes
Change method	Battery option change	Battery option change	Battery change
Appearance			
Compatible model	E/EH EM/EMH EJ/EJH	- ○ ○	○ ○ ○

■Cell battery (MDS-BAT6V1SET)

Specifications

Battery option type	Cell battery MDS-BAT6V1SET
Battery model name	2CR17335A
Nominal voltage	6V
Number of connectable axes (Note 1)	Up to 3 axes
Battery continuous backup time	Up to 2 axes: Approx. 10,000 hours 3 axes connected: Approx. 6,600 hours
Back up time from battery warning to alarm occurrence (Note 2)	Up to 2 axes: Approx. 100 hours 3 axes connected: Approx. 60 hours
Compatible model	E/EH EM/EMH EJ/EJH

(Note 1) When using ball screw side encoder, both ball screw side encoder and motor side encoder need to be backed up by a battery, so the load becomes double.
(Note 2) This time is a guideline, so does not guarantee the back up time. Replace the battery with a new battery as soon as a battery warning occurs.
(Note 3) A battery load is generated in the axis for which the incremental control is set when a battery is connected.

■Cell battery (MR-BAT6V1SET)

Specifications

Battery option type	Cell battery MR-BAT6V1SET
Battery model name	2CR17335A
Nominal voltage	6V
Number of connectable axes (Note 1)	Up to 3 axes
Battery continuous backup time	Up to 2 axes: Approx. 10,000 hours 3 axes connected: Approx. 6,600 hours
Back up time from battery warning to alarm occurrence (Note 2)	Up to 2 axes: Approx. 100 hours 3 axes connected: Approx. 60 hours
Compatible model	E/EH EM/EMH EJ/EJH

(Note 1) When using ball screw side encoder, both ball screw side encoder and motor side encoder need to be backed up by a battery, so load becomes double.
(Note 2) This time is a guideline, so does not guarantee the back up time. Replace the battery with a new battery as soon as a battery alarm occurs.
(Note 3) A battery load is generated in the axis for which the incremental control is set when a battery is connected.

■Battery box (MDSBTBOX-LR2060)

Specifications

Battery option type		Battery box
Battery model name (Note 1)		MDSBTBOX-LR2060
Nominal voltage (Note 2)		Size-D alkaline batteries LR20×4 pieces 6.0V (Unit output: BTO1/2/3) 3.6V (Unit output: BT(3.6V))
Number of connectable axes (Note 3)		8 axes
Battery continuous backup time (Note 4)		Approx. 10000 hours (when 8 axes are connected, cumulative time in non-energized state)
Back up time from battery warning to alarm occurrence (Note 4)		Approx. 336 hours (when 8 axes are connected)
Compatible model	E/EH	○
	EM/EMH	○
	EJ/EJH	○

(Note 1) Install commercially-available alkaline dry batteries into MDSBTBOX-LR2060. The batteries should be procured by customers. Make sure to use new batteries that have not passed the expiration date. We recommend you to replace the batteries in the one-year cycle.

(Note 2) 3.6V output is for old-type drive unit. It is not used for MDS-E/EH, EM/EMH, and EJ/EJH Series.

(Note 3) When using ball screw side encoder, both ball screw side encoder and motor side encoder need to be backed up by a battery, so the load becomes double.

(Note 4) This time is a guideline, so does not guarantee the back up time. Replace the battery with a new battery as soon as a battery warning (9F) occurs.

(Note 5) A battery load is generated in the axis for which the incremental control is set when a battery is connected.

■Ball screw side encoder OSA405ET2AS, OSA676ET2AS

Specifications

Type	OSA405ET2AS	OSA676ET2AS	
Electrical characteristics	Encoder resolution	4,194,304pulse/rev	67,108,864pulse/rev
	Detection method	Absolute position method (battery backup method)	
	Accuracy (*1)	±3 seconds	
	Tolerable rotation speed at power off (*2)	500r/min	
	Encoder output data	Serial data	
Mechanical characteristics for rotation	Power consumption	0.3A	
	Inertia	0.5×10 ⁻⁴ kgm ² or less	
	Shaft friction torque	0.1Nm or less	
	Shaft angle acceleration	4×10 ⁴ rad/s ² or less	
	Tolerable continuous rotation speed	4000r/min	
Mechanical configuration	Shaft amplitude (position 15mm from end)	0.02mm or less	
	Tolerable load (thrust direction/radial direction)	9.8N/19.6N	
	Mass	0.6kg	
	Degree of protection	IP67 (The shaft-through portion is excluded.)	
	Recommended coupling	Bellows coupling	
Compatible model	E/EH	○	○
	EM/EMH	○	-
	EJ/EJH	○	-

(*1) The values above are typical values after the calibration with our shipping test device and are not guaranteed.

(*2) If the tolerable rotation speed at power off is exceeded, the absolute position cannot be repaired.

Outline dimension drawing

OSA405ET2AS/OSA676ET2AS

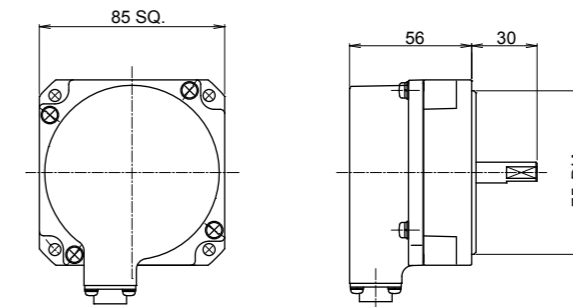

[Unit : mm]

SPINDLE OPTIONS

According to the spindle control to be adopted, select the spindle side encoder based on the following table.

No-variable speed control (When spindle and motor are directly coupled or coupled with a 1:1 gear ratio)

●: Control possible x: Control not possible

Spindle control item	Control specifications	Without spindle side encoder		With spindle side encoder	
Spindle control	Normal cutting control	●		This normally is not used for novariable speed control.	
	Constant surface speed control (lathe)	●			
	Thread cutting (lathe)	●			
Orientation control	1-point orientation control	●			
	Multi-point orientation control	●			
	Orientation indexing	●			
Synchronous tap control	Standard synchronous tap	●			
	Synchronous tap after zero point return	●			
Spindle synchronous control	Without phase alignment function	●			
	With phase alignment function	●			
C-axis control	C-axis control	● (Note)			●

(Note) When spindle and motor are coupled with a 1:1 gear ratio, use of a spindle side encoder is recommended to assure the precision.

Variable speed control (When using V-belt, or when spindle and motor are connected with a gear ratio other than 1:1)

●: Control possible x: Control not possible

Spindle control item	Control specifications	Without spindle side encoder	With spindle side encoder		
			TS5690/ERM280/GEL2449M	OSE-1024	Proximity switch
Spindle control	Normal cutting control	●	●	●	●
	Constant surface speed control (lathe)	● (Note 1)	●	●	● (Note 1)
	Thread cutting (lathe)	x	●	●	x
Orientation control	1-point orientation control	x	●	●	● (Note 3)
	Multi-point orientation control	x	●	●	x
	Orientation indexing	x	●	●	x
Synchronous tap control	Standard synchronous tap	● (Note 2)	●	●	● (Note 2)
	Synchronous tap after zero point return	x	●	●	x
Spindle synchronous control	Without phase alignment function	● (Note 1)	●	●	● (Note 1)
	With phase alignment function	x	●	●	x
C-axis control	C-axis control	x	●	x	x

(Note 1) Control not possible when connected with the V-belt.

(Note 2) Control not possible when connected with other than the gears.

(Note 3) When using a proximity switch, an orientation is executed after the spindle is stopped. As for 2-axis spindle drive unit, setting is available only for one of the axes.

Spindle side ABZ pulse output encoder (OSE-1024 Series)

When a spindle and motor are connected with a V-belt, or connected with a gear ratio other than 1:1, use this spindle side encoder to detect the position and speed of the spindle. Also use this encoder when orientation control and synchronous tap control, etc are executed under the above conditions.

Specifications

Type	OSE-1024-3-15-68		OSE-1024-3-15-68-8	
Mechanical characteristics for rotation	Inertia	0.1x10 ⁻⁴ kgm ² or less	0.1x10 ⁻⁴ kgm ² or less	0.1x10 ⁻⁴ kgm ² or less
	Shaft friction torque	0.98Nm or less	0.98Nm or less	0.98Nm or less
	Shaft angle acceleration	10°rad/s ² or less	10°rad/s ² or less	10°rad/s ² or less
	Tolerable continuous rotation speed	6000r/min	8000r/min	8000r/min
Mechanical configuration	Bearing maximum non-lubrication time	20000h/6000r/min	20000h/8000r/min	20000h/8000r/min
	Shaft amplitude (position 15mm from end)	0.02mm or less	0.02mm or less	0.02mm or less
	Tolerable load (thrust direction/radial direction)	10kg/20kg Half of value during operation	10kg/20kg Half of value during operation	10kg/20kg Half of value during operation
	Mass	1.5kg	1.5kg	1.5kg
	Degree of protection	IP54		
	Squareness of flange to shaft	0.05mm or less		
Compatible model	Flange matching eccentricity	0.05mm or less		
	E/EH	○	○	○
	EM/EMH	○	○	○
	EJ/EJH	○	○	○

(Note1) Confirm that the gear ratio (pulley ratio) of the spindle end to the encoder is 1:1.

(Note2) Use a timing belt when connecting by a belt.

Outline dimension drawing

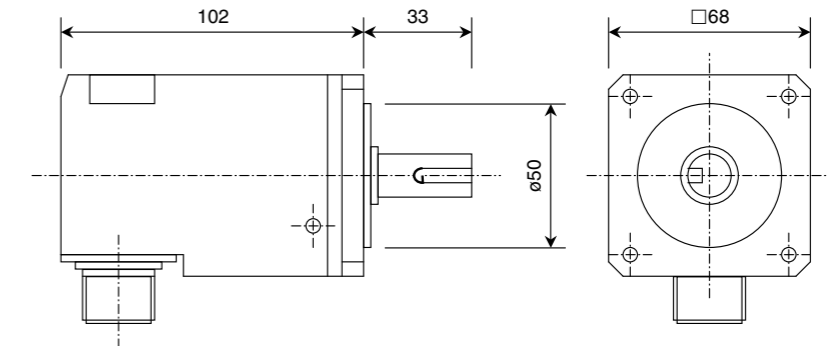

Spindle side encoder (OSE-1024-3-15-68, OSE-1024-3-15-68-8)

[Unit : mm]

■ Spindle side PLG serial output encoder (TS5690, MU1606 Series)

This encoder is used when a more accurate synchronous tapping control or C-axis control than OSE encoder is performed to the spindle which is not directly-connected to the spindle motor.

Specifications

Sensor	Series type		TS5690N64xx									
	xx (The end of the type name)	Standard connector Water-proof connector	12	22	32	42	52	17	27	37	47	57
			19	29	39	49	59	18	28	38	48	58
	Length of lead [mm]		400±10	800±20	1200±20	1600±30	2000±30	400±10	800±20	1200±20	1600±30	2000±30
	Lead wire lead-out direction		Vertical direction					Shaft direction				
Detection gear	Type		MU1606N601									
	The number of teeth		64									
	Outer diameter [mm]		ø52.8									
	Inner diameter [mm]		ø40H5									
Notched fitting section	Thickness [mm]		12									
	Outer diameter [mm]		ø59.4									
The number of output pulse	Outer diameter tolerance [mm]		-0.070 to -0.030									
	A/B phase		64									
Detection resolution [p/rev]	Z phase		1									
			2 million									
Absolute accuracy at stop			150°									
			40,000									
Tolerable speed [r/min]			Mitsubishi high-speed serial									
			E/EH EM/EMH EJ/EJH									

Sensor	Series type		TS5690N90xx									
	xx (The end of the type name)	Standard connector Water-proof connector	12	22	32	42	52	17	27	37	47	57
			19	29	39	49	59	18	28	38	48	58
	Length of lead [mm]		400±10	800±20	1200±20	1600±30	2000±30	400±10	800±20	1200±20	1600±30	2000±30
	Lead wire lead-out direction		Vertical direction					Shaft direction				
Detection gear	Type		MU1606N906									
	The number of teeth		90									
	Outer diameter [mm]		ø73.6									
	Inner diameter [mm]		ø60H5									
Notched fitting section	Thickness [mm]		12									
	Outer diameter [mm]		ø79.2									
The number of output pulse	Outer diameter tolerance [mm]		-0.040 to 0									
	A/B phase		90									
Detection resolution [p/rev]	Z phase		1									
			2,880,000									
Absolute accuracy at stop			105°									
			30,000									
Tolerable speed [r/min]			Mitsubishi high-speed serial									
			E/EH EM/EMH EJ/EJH									

Sensor	Series type		TS5690N12xx									
	xx (The end of the type name)	Standard connector Water-proof connector	12	22	32	42	52	17	27	37	47	57
			19	29	39	49	59	18	28	38	48	58
	Length of lead [mm]		400±10	800±20	1200±20	1600±30	2000±30	400±10	800±20	1200±20	1600±30	2000±30
	Lead wire lead-out direction		Vertical direction					Shaft direction				
Detection gear	Type		MU1606N709									
	The number of teeth		128									
	Outer diameter [mm]		ø104.0									
	Inner diameter [mm]		ø80H5									
Notched fitting section	Thickness [mm]		12									
	Outer diameter [mm]		ø108.8									
The number of output pulse	Outer diameter tolerance [mm]		-0.015 to +0.025									
	A/B phase		128									
Detection resolution [p/rev]	Z phase		1									
			4 million									
Absolute accuracy at stop			100°									
			20,000									
Tolerable speed [r/min]			Mitsubishi high-speed serial									
			E/EH EM/EMH EJ/EJH									

Sensor	Series type		TS5690N19xx									
	xx (The end of the type name)	Standard connector Water-proof connector	12	22	32	42	52	17	27	37	47	57
			19	29	39	49	59	18	28	38	48	58
	Length of lead [mm]		400±10	800±20	1200±20	1600±30	2000±30	400±10	800±20	1200±20	1600±30	2000±30
	Lead wire lead-out direction		Vertical direction					Shaft direction				
Detection gear	Type		MU1606N203									
	The number of teeth		192									
	Outer diameter [mm]		ø155.2									
	Inner diameter [mm]		ø125H5									
Notched fitting section	Thickness [mm]		12									
	Outer diameter [mm]		ø159.4									
The number of output pulse	Outer diameter tolerance [mm]		-0.035 to +0.005									
	A/B phase		192									
Detection resolution [p/rev]	Z phase		1									
			6 million									
Absolute accuracy at stop			97.5°									
			15,000									
Tolerable speed [r/min]			Mitsubishi high-speed serial									
			E/EH EM/EMH EJ/EJH									

Sensor	Series type		TS5690N25xx									
	xx (The end of the type name)	Standard connector Water-proof connector	12	22	32	42	52	17	27	37	47	57
			19	29	39	49	59	18	28	38	48	58
	Length of lead [mm]		400±10	800±20	1200±20	1600±30	2000±30	400±10	800±20	1200±20	1600±30	2000±30
	Lead wire lead-out direction		Vertical direction					Shaft direction				
Detection gear	Type		MU1606N802									
	The number of teeth		256									
	Outer diameter [mm]		ø206.4									
	Inner diameter [mm]		ø160									
Notched fitting section	Thickness [mm]		15.8									
	Outer diameter [mm]		ø210.2									
The number of output pulse	Outer diameter tolerance [mm]		0.0 to +0.040									
	A/B phase		256									
Detection resolution [p/rev]	Z phase		1									
			8 million									
Absolute accuracy at stop			95°									
			10,000									
Tolerable speed [r/min]			Mitsubishi high-speed serial									
			E/EH EM/EMH EJ/EJH									

Outline dimension drawing

Lead wire lead-out direction: Vertical direction

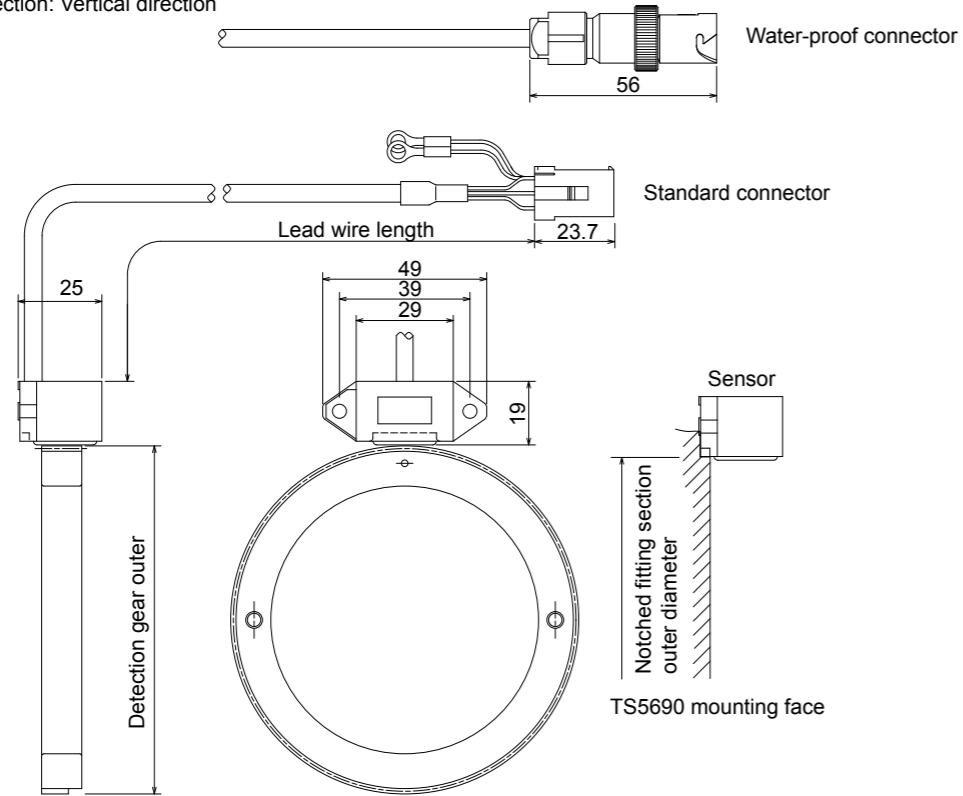

[Unit : mm]

Lead wire lead-out direction: Shaft direction

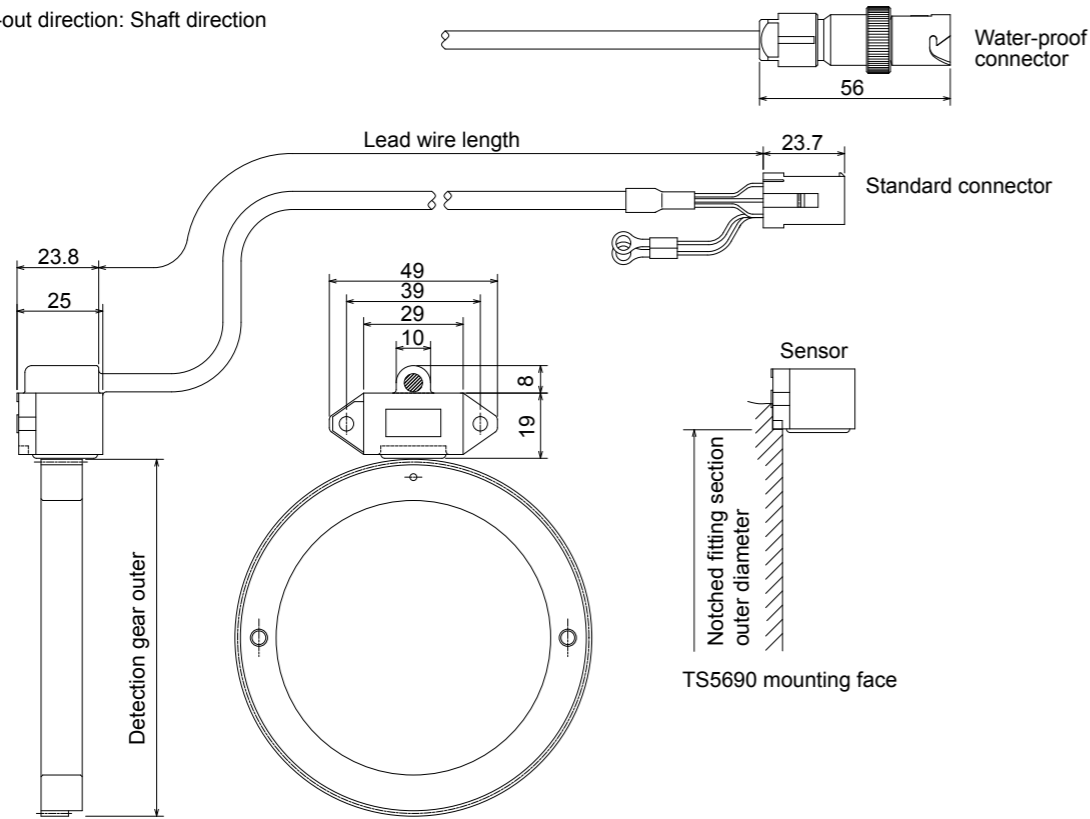

[Unit : mm]

Spindle side encoder (other manufacturer's product)

Encoder type	ERM280 1200	ERM280 2048	GEL2449M
Manufacturer	HEIDENHAIN CORPORATION		LENORD+BAUER
Minimum detection resolution	0.0000183° (19,660,800p/rev)	0.0000107° (33,554,432p/rev)	0.000687° (524,288p/rev)
Tolerable maximum speed	20000 r/min	11718 r/min	Depending on the diameter of the gear

ENCODER INTERFACE UNIT

Serial output interface unit for ABZ analog encoder MDS-EX-HR

This unit superimposes the scale analog output raw waves, and generates high resolution position data. Increasing the encoder resolution is effective for the servo high-gain.

Specifications

Type		MDS-EX-HR-11
Compatible scale (example)	LS186 / LS486 / LS186C / LS486C (HEIDENHAIN)	
Consumption current	150mA	
Analog signal input specifications	A-phase, B-phase, Z-phase (Amplitude 1Vp-p/Min.: 0.8Vp-p Max.: 1.2Vp-p)	
Compatible frequency	Analog raw waveform max.200kHz	
Scale resolution	Analog raw waveform / 16384 division	
Output communication style	High-speed serial communication	
Tolerable power voltage	5VDC±5%	
Maximum heating value	2W	
Mass	0.2kg	
Degree of protection	IP67	
Compatible model	E/EH	<input type="checkbox"/>
	EM/EMH	<input type="checkbox"/>
	EJ/EJH	<input type="checkbox"/>

Outline dimension drawing

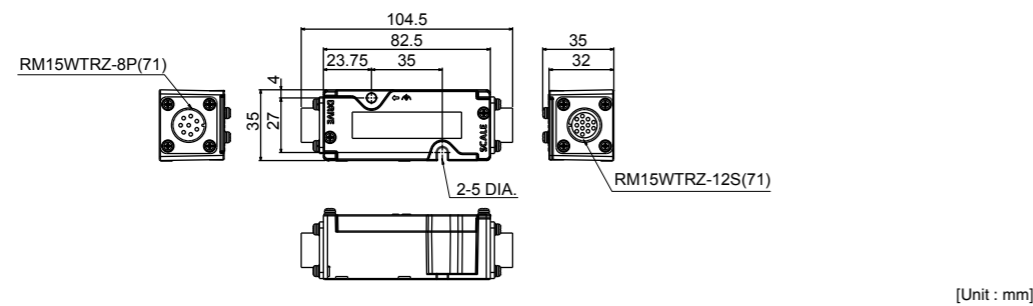

Serial output interface unit for ABZ analog encoder MDS-B-HR

Convert the analog waves (Phase A and B) output from the relative position linear scale into the Mitsubishi-protocol serial communication (digital) signal. Add the signal from the magnetic polar detection unit to the linear scale's feedback signal.

Specifications

Type		MDS-B-HR-11M	MDS-B-HR-11MP
Compatible scale (example)	LS186 / LS486 / LS186C / LS486C (HEIDENHAIN)		
Analog signal input specifications	A-phase, B-phase, Z-phase (Amplitude 1Vp-p)		
Compatible frequency	Analog raw waveform max. 200kHz		
Scale resolution	Analog raw waveform/512 division		
Input/output communication style	High-speed serial communication I/F, RS485 or equivalent		
Magnetic pole detection	Compatible		
Tolerable power voltage	DC5V±5%		
Maximum heating value	2W		
Mass	0.5kg or less		
Degree of protection	IP65	IP67	
Compatible model	E/EH	<input type="checkbox"/>	<input type="checkbox"/>
	EJ/EJH	<input type="checkbox"/>	<input type="checkbox"/>

Outline dimension drawing

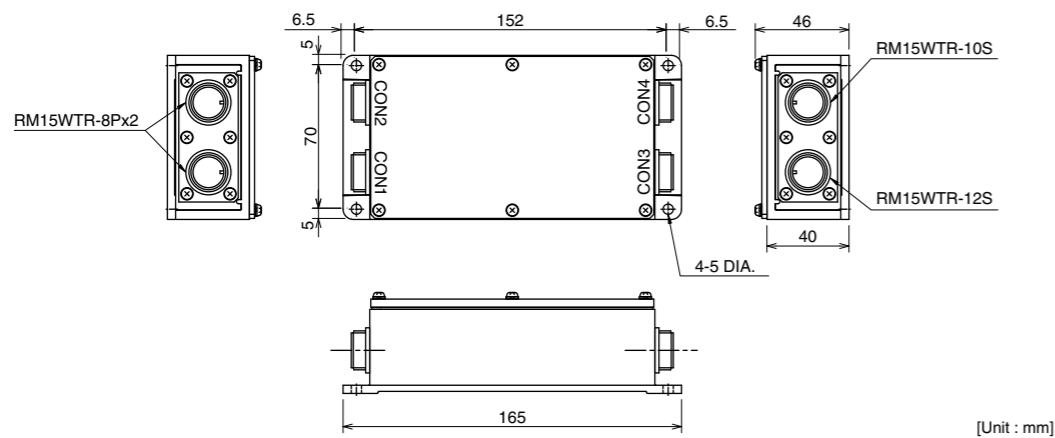

Serial signal division unit MDS-B-SD

This unit has a function to divide the position and speed signals fed back from the high-speed serial encoder and high-speed serial linear scale. This unit is used to carry out synchronized control of the motor with two MDS-E/EH-V1 drive units.

Specifications

Type		MDS-B-SD
Compatible servo drive unit	MDS-E/EH-V1-□	
Input/output communication style	High-speed serial communication I/F, RS485 or equivalent	
Tolerable power voltage	DC5V±10%	
Maximum heating value	4W	
Mass	0.5kg or less	
Degree of protection	IP20	
Compatible model	E/EH	<input type="checkbox"/>
	EM/EMH	<input type="checkbox"/>
	EJ/EJH	<input type="checkbox"/>

Outline dimension drawing

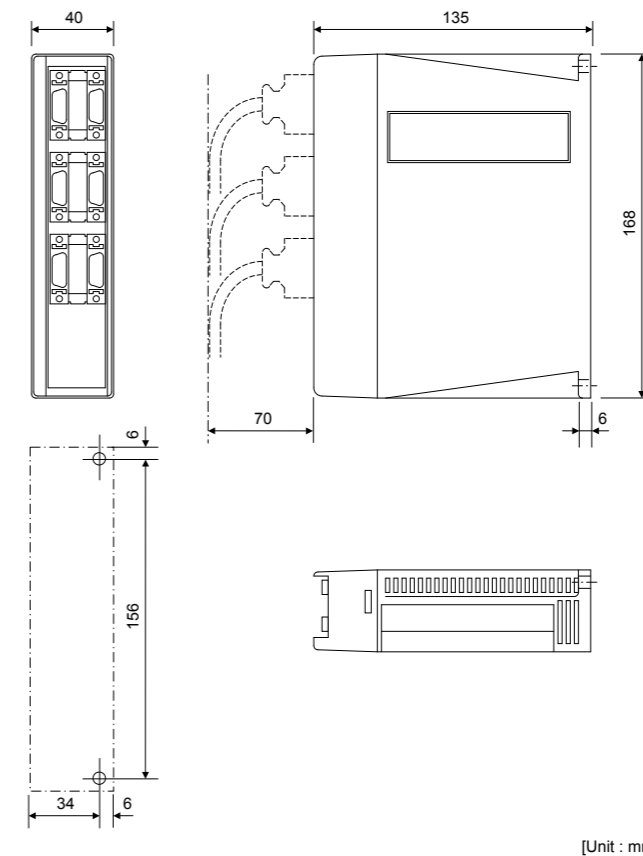

Serial output interface unit for ABZ analog encoder EIB192M (Other manufacturer's product)

Specifications

Type		EIB192M A4 20µm	EIB192M C4 1200	EIB192M C4 2048
Manufacturer	HEIDENHAIN			
Input signal	A-phase, B-phase: SIN wave 1Vpp, Z-phase			
Maximum input frequency	400kHz			
Output signal	Mitsubishi high-speed serial signal (Mitsu02-4)			
Interpolation division number	Maximum 16384 divisions			
Compatible encoder	LS187, LS487	ERM280 1200	ERM280 2048	
Minimum detection resolution	0.0012µm	0.0000183° (19,660,800p/rev)	0.0000107° (33,554,432p/rev)	
Degree of protection	IP65			
Outline dimension	98mm×64mm×38.5mm			
Mass	300g			
Compatible model	E/EH	<input type="checkbox"/>	<input type="checkbox"/>	<input type="checkbox"/>
	EM/EMH	<input type="checkbox"/>	<input type="checkbox"/>	<input type="checkbox"/>
	EJ/EJH	<input type="checkbox"/>	<input type="checkbox"/>	<input type="checkbox"/>

Serial output interface unit for ABZ analog encoder EIB392M (Other manufacturer's product)

Specifications

Type	EIB392M A4 20µm	EIB392M C4 1200	EIB392M C4 2048
Manufacturer	HEIDENHAIN		
Input signal	A-phase, B-phase: SIN wave 1Vpp, Z-phase		
Maximum input frequency	400kHz		
Output signal	Mitsubishi high-speed serial signal (Mitsu02-4)		
Interpolation division number	Maximum 16384 divisions		
Compatible encoder	LS187, LS487	ERM280 1200	ERM280 2048
Minimum detection resolution	0.0012µm	0.0000183° (19,660,800p/rev)	0.0000107° (33,554,432p/rev)
Degree of protection	IP40		
Outline dimension	76.5mm×43mm×16.6mm		
Mass	140g		
Compatible model	E/EH	○	○
	EM/EMH	○	○
	EJ/EJH	○	○

Serial output interface unit for ABZ analog encoder ADB-K70M Series (Other manufacturer's product)

Specifications

Type	ADB-K70M	
Manufacturer	Mitsubishi Heavy Industries Machine Tool Co., Ltd.	
Maximum response speed	10,000r/min	
Output signal	Mitsubishi high-speed serial signal	
Compatible encoder	MPRZ series	
Minimum detection resolution	0.000043° (8,388,608p/rev)	
Degree of protection	IP20	
Outline dimension	120mm×50mm×30mm	
Mass	0.15kg	
Compatible model	E/EH	○
	EM/EMH	○
	EJ/EJH	○

DRIVE UNIT OPTION

DC connection bar

When connecting a large capacity drive unit with L+L- terminal of power supply unit, DC connection bar is required. In use of the following large capacity drive units, use a dedicated DC connection bar. The DC connection bar to be used depends on the connected power supply, so make a selection according to the following table.

Specifications

Series	MDS-E		MDS-EH		
	Large capacity drive unit	MDS-E-SP-400 MDS-E-SP-640	MDS-E-SP-400 MDS-E-SP-640	MDS-EH-SP-200 MDS-EH-SP-320 MDS-EH-SP-480 MDS-EH-SP-600	MDS-EH-V1-200 MDS-EH-SP-200 MDS-EH-SP-320
Power supply unit	MDS-E-CV-300 MDS-E-CV-370 MDS-E-CV-450	MDS-E-CV-550	MDS-EH-CV-550 MDS-EH-CV-750 MDS-EX-CVP-1100H	MDS-E-CV-300 MDS-E-CV-370 MDS-E-CV-450	MDS-EH-CV-185
Required connection bar	E-BAR-B0606		E-BAR-A0606 (Two-parts set)	DH-BAR-B0606	DH-BAR-C0606
Compatible model	E/EH	○	○	○	○
	EM/EMH	-	-	-	-
	EJ/EJH	-	-	-	-

Outline dimension drawings

[Unit:mm]

E-BAR-A0606

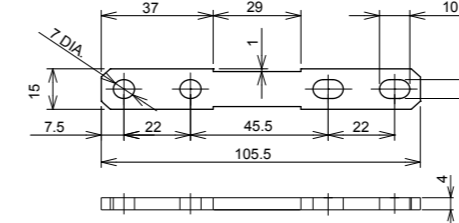

(Note) E-BAR-A0606 is a set of two DC connection bars.

E-BAR-B0606

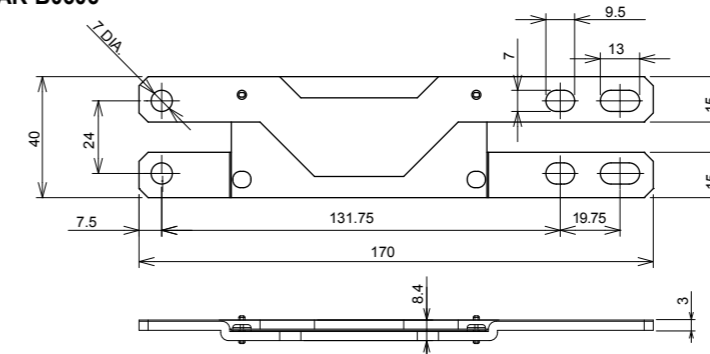

DH-BAR-B0606

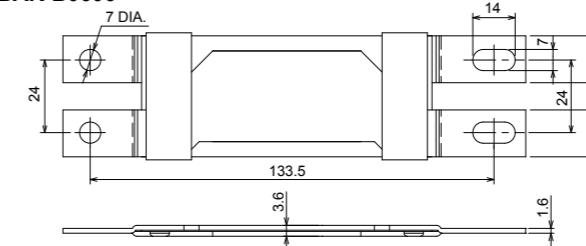

DH-BAR-C0606

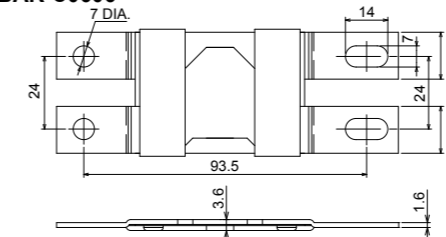

Side protection cover (E-COVER-1/E-COVER-2)

Install the side protection cover outside the both ends of the connected units.

■ Regenerative option

Confirm the regeneration resistor capacity and possibility of connecting with the drive unit. The regenerative resistor generates heats, so wire and install the unit while taking care to safety. When using the regenerative resistor, make sure that flammable matters, such as cables, do not contact the resistor, and provide a cover on the machine so that dust or oil does not accumulate on the resistor and ignite.

Combination with servo drive unit

Corresponding servo drive unit	Standard built-in regenerative resistor	External option regenerative resistor							
		MR-RB032	MR-RB12	MR-RB32	MR-RB30	MR-RB50	MR-RB31	MR-RB51	
	Mass	0.5kg	1.1kg	2.9kg	2.9kg	5.6kg	2.9kg	5.6kg	
	Unit outline dimension	168mm×30mm×119mm	168mm×40mm×149mm	150mm×100mm×318mm	150mm×100mm×318mm	150mm×100mm×318mm	150mm×100mm×318mm	350mm×128mm×200mm	
		W1	W2	W3	W3	W4	W3	W4	
	External option regenerative resistor	-	GZG200W39OHMK	GZG200W120OHMK×3	GZG200W39OHMK×3	GZG300W39OHMK×3	GZG200W20OHMK×3	GZG300W20OHMK×3	
	Regenerative capacity	30W	100W	300W	300W	500W	300W	500W	
		Resistance value	40Ω	40Ω	40Ω	13Ω	13Ω	6.7Ω	6.7Ω
MDS-EJ-V1-10	10W	100Ω	○	○					
MDS-EJ-V1-15	10W	100Ω	○	○					
MDS-EJ-V1-30	20W	40Ω	○	○	○				
MDS-EJ-V1-40	100W	13Ω				○	○		
MDS-EJ-V1-80	100W	9Ω				○	○	○	
MDS-EJ-V1-100	100W	9Ω				○	○	○	
MDS-EJ-V2-30	100W	9Ω				○	○		
MDS-EJ-V2-40	150W	6.7Ω				○	○	○	

Corresponding servo drive unit	Standard built-in regenerative resistor	External option regenerative resistor							
		FCUA-RB22	FCUA-RB37	FCUA-RB55	FCUA-RB75/2	FCUA-RB55 2 units connected in parallel	FCUA-RB75/2 2 units connected in parallel	R-UNIT	R-UNIT2
	Mass	0.8kg	1.2kg	2.2kg	2.2kg	4.4kg	4.4kg	4.3kg	4.4kg
	Unit outline dimension	30mm×60mm×215mm	30mm×60mm×335mm	40mm×80mm×400mm	40mm×80mm×400mm	40mm×80mm×400mm	40mm×80mm×400mm	355mm×105mm×114mm	355mm×105mm×114mm
		W5	W5	W6	W6	W6	W6	W7	W7
	Regenerative capacity	155W	185W	340W	340W	680W	680W	700W	700W
		Resistance value	40Ω	25Ω	20Ω	30Ω	10Ω	15Ω	30Ω
MDS-EJ-V1-10	10W	100Ω							
MDS-EJ-V1-15	10W	100Ω							
MDS-EJ-V1-30	20W	40Ω	○						
MDS-EJ-V1-40	100W	13Ω		○	○		○		○
MDS-EJ-V1-80	100W	9Ω							
MDS-EJ-V1-100	100W	9Ω							
MDS-EJ-V2-30	100W	9Ω		○	○				
MDS-EJ-V2-40	150W	6.7Ω				○	○		○

Corresponding servo drive unit	Standard built-in regenerative resistor	External option regenerative resistor			
		MR-RB1H-4	MR-RB3M-4	MR-RB3G-4	MR-RB5G-4 (Note 1)
	Mass	1.1kg	2.9kg	2.9kg	5.6kg
	Unit outline dimension	168mm×40mm×149mm	150mm×100mm×318mm	150mm×100mm×318mm	350mm×128mm×200mm
		W2	W3	W3	W4
	Regenerative capacity	100W	300W	300W	500W
		Resistance value	82Ω	120Ω	47Ω
MDS-EJH-V1-10	20W	80Ω	○	○	
MDS-EJH-V1-15	20W	80Ω	○	○	
MDS-EJH-V1-20	100W	40Ω			○
MDS-EJH-V1-40	120W	47Ω		○	○

(Note 1) Install a cooling fan in the unit.

Combination with spindle drive unit



The regenerative resistor is not incorporated in the spindle drive unit. Make sure to install the external option regenerative resistor.

Corresponding spindle drive unit		External option regenerative resistor			
		MR-RB12	MR-RB32	MR-RB30	MR-RB50
	Mass	0.8kg	2.9kg	2.9kg	5.6kg
	Unit outline dimension	168mm×40mm×149mm	150mm×100mm×318mm	150mm×100mm×318mm	350mm×128mm×200mm
		W2	W3	W3	W4
	External option regenerative resistor	GZG200W39OHMK	GZG200W120OHMK×3	GZG200W39OHMK×3	GZG300W39OHMK×3
	Regenerative capacity	100W	300W	300W	500W
	Resistance value	40Ω	40Ω	13Ω	13Ω
MDS-EJ-SP-20	-	○	○		
MDS-EJ-SP-40	-			○	○
MDS-EJ-SP-80	-			○	○
MDS-EJ-SP-100	-			○	○
MDS-EJ-SP-120	-			○	○
MDS-EJ-SP-160	-			○	○
MDS-EJ-SP2-20	-			○	○

Corresponding spindle drive unit		External option regenerative resistor			
		FCUA-RB22	FCUA-RB37	FCUA-RB55	FCUA-RB75/2 (1 unit)
	Mass	0.8kg	1.2kg	2.2kg	2.2kg
	Unit outline dimension	30mm×60mm×215mm	30mm×60mm×335mm	40mm×80mm×400mm	40mm×80mm×400mm
		W5	W5	W6	W6
	Regenerative capacity	155W	185W	340W	340W
	Resistance value	40Ω	25Ω	20Ω	30Ω
MDS-EJ-SP-20	-	○	○		
MDS-EJ-SP-40	-	○	○	○	○
MDS-EJ-SP-80	-		○	○	○
MDS-EJ-SP-100	-		○	○	○
MDS-EJ-SP-120	-				
MDS-EJ-SP-160	-				
MDS-EJ-SP2-20	-	○	○	○	

Corresponding spindle drive unit		External option regenerative resistor							
		R-UNIT1	R-UNIT2	R-UNIT3	R-UNIT4	R-UNIT5	FCUA-RB55 2 units connected in parallel	FCUA-RB75/2 2 units connected in parallel	
	Mass	4.3kg	4.4kg	10.8kg	11.0kg	15.0kg	4.4kg	4.4kg	
	Unit outline dimension	355mm×105mm×114mm	355mm×105mm×114mm	375mm×276mm×104mm	375mm×276mm×104mm	375mm×276mm×104mm	40mm×80mm×400mm	40mm×80mm×400mm	
		W7	W7	W8	W8	W9	W6	W6	
	Regenerative capacity	700W	700W	2100W	2100W	3100W	680W	680W	
	Resistance value	30Ω	15Ω	15Ω	10Ω	10Ω	10Ω	15Ω	
MDS-EJ-SP-20	-								
MDS-EJ-SP-40	-	○	○	○			○	○	
MDS-EJ-SP-80	-	○	○	○	○	○	○	○	
MDS-EJ-SP-100	-		○	○	○	○	○	○	
MDS-EJ-SP-120	-		○	○	○	○	○	○	
MDS-EJ-SP-160	-				○	○			
MDS-EJ-SP2-20	-								

External option regenerative resistor

[Unit : mm]

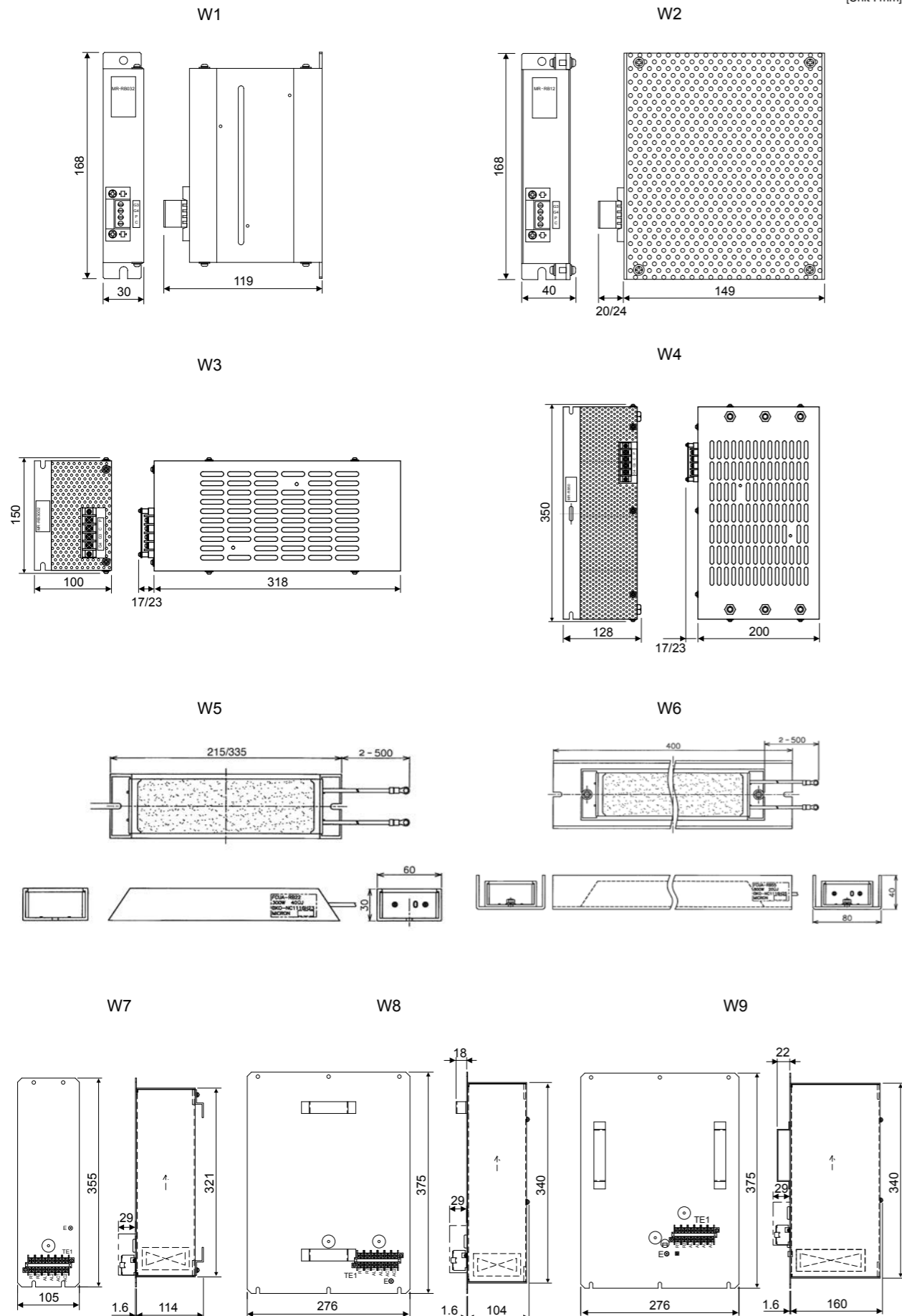

Power backup unit MDS-D/DH-PFU

Use this unit to protect machines or drive units at power failure.

Specifications

Power backup unit type		MDS-DH-PFU	MDS-D-PFU
AC Input	Rated voltage [V]	380 to 480AC (50/60Hz) (Exclusively for earthed-star supply system) Tolerable fluctuation : between +10% and -10%	200 to 230AC (50/60Hz) Tolerable fluctuation : between +10% and -15%
	Frequency [Hz]	50/60 Tolerable fluctuation : between +3% and -3%	
	Rated current [A]	2	4
DC Input/ Output	Rated voltage [V]	513 to 648DC	270 to 311DC
	Rated current [A]	Regenerative input: MAX 200A Power running output: MAX 160A	Regenerative input: MAX 300A Power running output: MAX 200A
AC output for control power backup	Voltage [V]	Single-phase 380 to 480VAC (50Hz or 60Hz) 50Hz at backup	Single-phase 200 to 230VAC (50Hz or 60Hz) 50Hz at backup
	Current [A]	MAX 2	MAX 4
	Maximum number of drive units to connect	6 units (except for the power supply unit)	
	Switching time	Within 100ms after AC input instantaneous interruption	
Minimum backup time	75ms or more (380VAC input, at maximum number of drive units to connect)		75ms or more (200VAC input, at maximum number of drive units to connect)
	Degree of protection		
Degree of protection			IP20 [except for the terminal block and connector area]
Cooling method			Natural-cooling
Mass [kg]			4

Outline dimension drawing

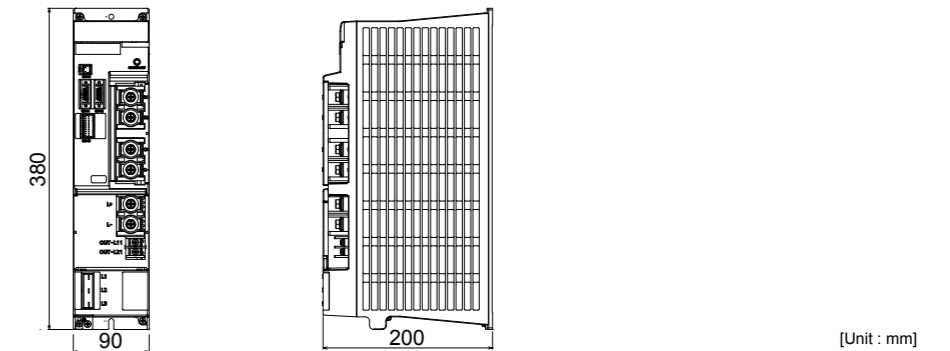

[Unit : mm]

Regenerative resistor unit for power backup unit R-UNIT-6, R-UNIT-7

Specifications

Regenerative resistor type	R-UNIT-6	R-UNIT-7
Corresponding power backup unit type	MDS-DH-PFU	MDS-D-PFU
Resistance value [Ω]	5	1.4
Instantaneous regeneration capacity [kW]	128	114
Tolerable regeneration work amount [kJ]	180	180
Cooling method	Natural-cooling	Natural-cooling
Mass [kg]	10	10

Outline dimension drawing

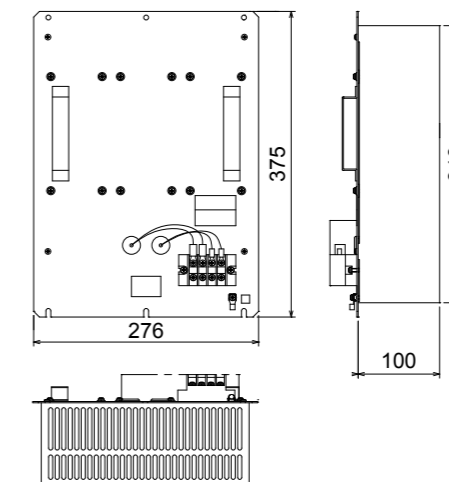

[Unit : mm]

■Capacitor unit MDS-D/DH-CU

Specifications

Capacitor unit type		MDS-DH-CU	MDS-D-CU
Compatible capacitor unit type		MDS-DH-PFU	MDS-D-PFU
Capacity [μF]		7000	28000
DC Input/Output	Rated voltage [V]	513 to 648DC	270 to 311DC
Cooling method		Natural-cooling	Natural-cooling
Mass [kg]		11	11

Outline dimension drawing

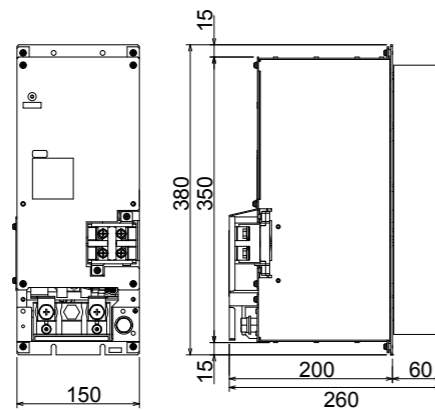

[Unit : mm]

SELECTION OF CABLES AND CONNECTORS

The following are the selection lists of the cables and connectors provided by Mitsubishi. Refer to Specifications manual of each drive system series when manufacturing the cables. (For E/EH Series, refer to "6.1 Selection of Wire" and "8.1 Selection of Cable".)

■MDS-E Series Power Cable/Connector and Brake Cable/Connector for Servo Motor Selection List

Servo motor type	Drive unit type MDS-E-			Power Cable				Brake Cable	
				Single connector		Cable		Single connector	Cable
				Drive unit side		Motor side		Drive unit side	Motor side
V1	V2	V3	Lead out in direction of motor shaft	Lead out in opposite direction of motor shaft	Lead out in direction of motor shaft	Lead out in opposite direction of motor shaft			
HG Series	HG46	20	20	- All axes CNU01SEF (AWG14) - L-axis only CNU01SEL (AWG14) - M-axis only CNU01SEM (AWG14) - S-axis only CNU01SES (AWG14)	MR-PWS1CBL □ M-A1-H □ : Length (m) 2, 3, 5, 7, 10	MR-PWS1CBL □ M-A2-H □ : Length (m) 2, 3, 5, 7, 10	CNU23S (AWG14)	MR-BKS1CBL □ M-A1-H □ : Length (m) 2, 3, 5, 7, 10	MR-BKS1CBL □ M-A2-H □ : Length (m) 2, 3, 5, 7, 10

Servo motor type	Drive unit type MDS-E-			Power Connector				Brake Connector		
				Drive unit side		Motor side		Drive unit side	Motor side	
				Straight		Right angle		Straight		Right angle
HG Series	HG75□-S105010	20	40	40	- All axes CNU01SEF (AWG14) - L-axis only CNU01SEL (AWG14) - M-axis only CNU01SEM (AWG14) - S-axis only CNU01SES (AWG14)	CNP14-2S (12) Applicable cable outline ø10 to 12 (mm)	CNP14-2L (12) Applicable cable outline ø10 to 12 (mm)	CNU23S (AWG14)	CNB10-R2S (6) CNB10S-R2S (6) Applicable cable outline ø4.0 to 6.0 (mm)	CNB10-R2L (6) CNB10S-R2L (6) Applicable cable outline ø4.0 to 6.0 (mm)
	HG75					CNP18-10S (14) Applicable cable outline ø10.5 to 14 (mm)	CNP18-10L (14) Applicable cable outline ø10.5 to 14 (mm)			
	HG105					CNP22-22S (16) Applicable cable outline ø12.5 to 16 (mm)	CNP22-22L (16) Applicable cable outline ø12.5 to 16 (mm)			
	HG123					CNP18-10S (14) Applicable cable outline ø10.5 to 14 (mm)	CNP18-10L (14) Applicable cable outline ø10.5 to 14 (mm)			
	HG142					CNP22-22S (16) Applicable cable outline ø12.5 to 16 (mm)	CNP22-22L (16) Applicable cable outline ø12.5 to 16 (mm)			
	HG54	40	80	80		CNP18-10S (14) Applicable cable outline ø10.5 to 14 (mm)	CNP18-10L (14) Applicable cable outline ø10.5 to 14 (mm)			
	HG104					CNP22-22S (16) Applicable cable outline ø12.5 to 16 (mm)	CNP22-22L (16) Applicable cable outline ø12.5 to 16 (mm)			
	HG223					CNP32-17S (23) Applicable cable outline ø22 to 23.8 (mm)	CNP32-17L (23) Applicable cable outline ø22 to 23.8 (mm)			
	HG302	80	160	80		Terminal block connection				
	HG154					CNP18-10S (14) Applicable cable outline ø10.5 to 14 (mm)	CNP18-10L (14) Applicable cable outline ø10.5 to 14 (mm)			
	HG224					CNP22-22S (16) Applicable cable outline ø12.5 to 16 (mm)	CNP22-22L (16) Applicable cable outline ø12.5 to 16 (mm)			
	HG204					CNP18-10S (14) Applicable cable outline ø10.5 to 14 (mm)	CNP18-10L (14) Applicable cable outline ø10.5 to 14 (mm)			
	HG303					CNP22-22S (16) Applicable cable outline ø12.5 to 16 (mm)	CNP22-22L (16) Applicable cable outline ø12.5 to 16 (mm)			
	HG354	160	160W	—		Terminal block connection				
	HG453					CNP18-10S (14) Applicable cable outline ø10.5 to 14 (mm)	CNP18-10L (14) Applicable cable outline ø10.5 to 14 (mm)			
HG603	CNP22-22S (16) Applicable cable outline ø12.5 to 16 (mm)				CNP22-22L (16) Applicable cable outline ø12.5 to 16 (mm)					
HG702	160W	160W	—	Terminal block connection						
HG703	320	—	—	Terminal block connection						
HG903	320W	—	—	Terminal block connection						
HG1103	320W	—	—	Terminal block connection						

■MDS-E Series Encoder Cable and Connector for Servo Motor Selection List

Servo motor type	Drive unit type MDS-E-			Servo encoder cable									
				Motor side encoder cable				Ball screw side encoder cable					
				Cable (for D47/D48/D51/D74)		Single connector		Cable		Single connector			
				Straight	Right angle	Drive unit side	Motor side	Straight	Right angle	Straight	Right angle		
HG Series	HG46	20	40	CNP2E-8P-□ □ : Length (m) 2, 3, 4, 5, 7, 10, 15, 20, 25, 30	CNP2E-9P-□ □ : Length (m) 2, 3, 4, 5, 7, 10, 15, 20, 25, 30	CNU2S (AWG18)	CNE10-R10S (9) CNE10S-R10S (9) Applicable cable outline ø6.0 to 9.0 (mm)	CNE10-R10L (9) CNE10S-R10L (9) Applicable cable outline ø6.0 to 9.0 (mm)	CNP2E-8P-□ □ : Length (m) 2, 3, 4, 5, 7, 10, 15, 20, 25, 30	CNP2E-9P-□ □ : Length (m) 2, 3, 4, 5, 7, 10, 15, 20, 25, 30	CNE10-R10S (9) CNE10S-R10S (9) Applicable cable outline ø6.0 to 9.0 (mm)	CNE10-R10L (9) CNE10S-R10L (9) Applicable cable outline ø6.0 to 9.0 (mm)	

■MDS-E Series Power Connector for Spindle Motor Selection List

Spindle motor type	Drive unit type MDS-E-		Power Connector	
	SP	SP2	Drive unit side	Motor side
SJ-D Series (Normal)	SJ-D3.7/100-01	80 16080 (M)	Terminal block connection	- All axes CNU01SEF (AWG14) - L-axis only CNU01SEL (AWG14) - M-axis only CNU01SEM (AWG14)
	SJ-D5.5/100-01			
	SJ-D5.5/120-01			
	SJ-D5.5/120-02	160 200		
	SJ-D7.5/100-01	160 16080 (L)		
	SJ-D7.5/120-01			
	SJ-D11/100-01	200 —		
	SJ-D15/80-01			
	SJ-D18.5/80-01			
	SJ-D Series (Hollow shaft)	SJ-D22/80-01		
SJ-D26/80-01		320 —		
SJ-DG Series (High output)	SJ-D5.5/120-02T-S	160 200	16080 (L)	
	SJ-DG3.7/120-03T	160 —	Terminal block connection	
	SJ-DG5.5/120-04T			
	SJ-DG7.5/120-05T			
	SJ-DG11/100-03T	200 —		
	SJ-DG11/120-03T	160 200		16080(L)
SJ-DG15/120-02T-K	200 240	—		
SJ-DJ Series (Compact & lightweight)	SJ-DJ5.5/100-01	80 16080 (M)	- All axes CNU01SEF (AWG14) - L-axis only CNU01SEL (AWG14) - M-axis only CNU01SEM (AWG14)	
	SJ-DJ5.5/120-01	80 16080 (M)	- All axes CNU01SEF (AWG14) - L-axis only CNU01SEL (AWG14) - M-axis only CNU01SEM (AWG14)	
	SJ-DJ7.5/100-01	160 16080 (L)	Terminal block connection	
	SJ-DJ7.5/120-01			
	SJ-DJ11/100-01			
SJ-DJ15/80-01				
SJ-DL0.75/100-01	20 20	- All axes CNU01SEF (AWG14) - L-axis only CNU01SEL (AWG14) - M-axis only CNU01SEM (AWG14)		
SJ-DL Series (Low-inertia)	SJ-DL1.5/100-01	40 40	- All axes CNU01SEF (AWG14) - L-axis only CNU01SEL (AWG14) - M-axis only CNU01SEM (AWG14)	
	SJ-DL3.7/240-01T	200 —	Terminal block connection	
	SJ-DL5.5/150-01T	160 16080 (L)		
	SJ-DL5.5/200-01T	200 —		
	SJ-DL5.5/240-05T	200 —		
	SJ-DL7.5/150-01T	160 16080 (L)		
SJ-DL Series (Hollow shaft)	SJ-DL5.5/200-01T-S	160 16080 (L)		
SJ-DN Series (High-torque specifications)	SJ-DN7.5/80-01	160 16080 (L)	Terminal block connection	
	SJ-DN11/80-01	200 —		
	SJ-DN15/80-01	200 —		
	SJ-DN18.5/80-01	200 —		
SJ-V Series (Normal)	SJ-V2.2-01T	40 40	- All axes CNU01SEF (AWG14) - L-axis only CNU01SEL (AWG14) - M-axis only CNU01SEM (AWG14)	
	SJ-V3.7-02ZT	80 16080 (M)	Terminal block connection	
	SJ-V15-09ZT	200 —		
	SJ-V18.5-01ZT			
	SJ-V18.5-04ZT	240 —		
	SJ-V22-01ZT			
	SJ-V22-04ZT	320 —		
	SJ-V22-06ZT			
	SJ-V26-01ZT	320 —		
	SJ-V37-01ZT			
	SJ-V45-01ZT	400 —		
SJ-V55-01ZT				
SJ-V Series (Wide range constant output)	SJ-V11-01T	160 16080 (L)		
	SJ-V11-09T			
	SJ-V15-03T	200 —		
	SJ-V18.5-03T	240 —		
	SJ-V22-05T	320 —		
SJ-V22-09T				
SJ-VL Series (Low-inertia)	SJ-VK22-19ZT	40 40	- All axes CNU01SEF (AWG14) - L-axis only CNU01SEL (AWG14) - M-axis only CNU01SEM (AWG14)	
	SJ-VL2.2-02ZT	160 16080 (L)	Terminal block connection	
	SJ-VL11-02FZT			
SJ-VL11-05FZT-S01				

■MDS-E Series Encoder Cable and Connector for Spindle Motor Selection List

Spindle motor type	Drive unit type MDS-E-	Spindle encoder cable											
		When connecting to a spindle motor			When connecting to a spindle side encoder								
		Motor side PLG cable			Spindle side accuracy encoder TS5690 cable				Spindle side encoder OSE-1024 cable				
		Cable	Single connector		Cable	Single connector			Cable		Single connector		
Drive unit side	Encoder side		Drive unit side	Encoder side		Straight	Right angle	Drive unit side	Encoder side				
SJ-D Series (Normal)	SJ-D3.7/100-01	80 16080 (M)	CNP2E-1-□M □ : Length (m) 2, 3, 4, 5, 7, 10, 15, 20, 25, 30	CNU2S (AWG18)	CNEPGS	CNP2E-1-□M □ : Length (m) 2, 3, 4, 5, 7, 10, 15, 20, 25, 30	CNU2S (AWG18)	CNEPGS	CNP3EZ-2P-□M □ : Length (m) 2, 3, 4, 5, 7, 10, 15, 20, 25, 30	CNP3EZ-3P-□M □ : Length (m) 2, 3, 4, 5, 7, 10, 15, 20, 25, 30	CNEPGS	CNE20-29S (10) Applicable cable outline ø6.8 to 10 (mm)	CNE20-29L (10) Applicable cable outline ø6.8 to 10 (mm)
	SJ-D5.5/100-01												
	SJ-D5.5/120-01												
	SJ-D5.5/120-02	160 200											
	SJ-D7.5/100-01	160 16080 (L)											
	SJ-D7.5/120-01												
	SJ-D11/100-01	200 —											
	SJ-D15/80-01												
	SJ-D18.5/80-01												
	SJ-D Series (Hollow shaft)	SJ-D22/80-01											
SJ-D26/80-01		320 —											
SJ-DG Series (High output)	SJ-D5.5/120-02T-S	160 200	16080 (L)										
	SJ-DG3.7/120-03T	160 —	Terminal block connection										
	SJ-DG5.5/120-04T												
	SJ-DG7.5/120-05T												
	SJ-DG11/100-03T	200 —											
	SJ-DG11/120-03T	160 200		16080 (L)									
SJ-DG15/120-02T-K	200 240	—											
SJ-DJ Series (Compact & lightweight)	SJ-DJ5.5/100-01	80 16080 (M)	- All axes CNU01SEF (AWG14) - L-axis only CNU01SEL (AWG14) - M-axis only CNU01SEM (AWG14)										
	SJ-DJ5.5/120-01	80 16080 (M)	- All axes CNU01SEF (AWG14) - L-axis only CNU01SEL (AWG14) - M-axis only CNU01SEM (AWG14)										
	SJ-DJ7.5/100-01	160 16080 (L)	Terminal block connection										
	SJ-DJ7.5/120-01												
	SJ-DJ11/100-01												
SJ-DJ15/80-01													
SJ-DL0.75/100-01	20 20	- All axes CNU01SEF (AWG14) - L-axis only CNU01SEL (AWG14) - M-axis only CNU01SEM (AWG14)											
SJ-DL Series (Low-inertia)	SJ-DL1.5/100-01	40 40	- All axes CNU01SEF (AWG14) - L-axis only CNU01SEL (AWG14) - M-axis only CNU01SEM (AWG14)										
	SJ-DL3.7/240-01T	200 —	Terminal block connection										
	SJ-DL5.5/150-01T	160 16080 (L)											
	SJ-DL5.5/200-01T	200 —											
	SJ-DL5.5/240-05T	200 —											
	SJ-DL7.5/150-01T	160 16080 (L)											
SJ-DL Series (Hollow shaft)	SJ-DL5.5/200-01T-S	160 16080 (L)											
SJ-DN Series (High-torque specifications)	SJ-DN7.5/80-01	160 16080 (L)	Terminal block connection										
	SJ-DN11/80-01	200 —											
	SJ-DN15/80-01	200 —											
	SJ-DN18.5/80-01	200 —											
SJ-V Series (Normal)	SJ-V2.2-01T	40 40	- All axes CNU01SEF (AWG14) - L-axis only CNU01SEL (AWG14) - M-axis only CNU01SEM (AWG14)										
	SJ-V3.7-02ZT	80 16080 (M)	Terminal block connection										
	SJ-V15-09ZT	200 —											
	SJ-V18.5-01ZT												
	SJ-V18.5-04ZT	240 —											
	SJ-V22-01ZT												
	SJ-V22-04ZT	320 —											
	SJ-V22-06ZT												
	SJ-V26-01ZT	320 —											
	SJ-V37-01ZT												
	SJ-V45-01ZT	400 —											
SJ-V55-01ZT													
SJ-V Series (Wide range constant output)	SJ-V11-01T	160 16080 (L)											
	SJ-V11-09T												
	SJ-V15-03T	200 —											
	SJ-V18.5-03T	240 —											
	SJ-V22-05T	320 —											
SJ-V22-09T													
SJ-VL Series (Low-inertia)	SJ-VK22-19ZT	40 40	- All axes CNU01SEF (AWG14) - L-axis only CNU01SEL (AWG14) - M-axis only CNU01SEM (AWG14)										
	SJ-VL2.2-02ZT	160 16080 (L)	Terminal block connection										
	SJ-VL11-02FZT												
SJ-VL11-05FZT-S01													

■MDS-EM Series Power Cable/Connector and Brake Cable/Connector for Servo Motor Selection List

Servo motor type	Drive unit type MDS-EM-SPV3	Power Cable		Brake Cable			
		Single connector	Cable		Cable		
		Drive unit side	Motor side		Motor side		
		Lead out in direction of motor shaft	Lead out in opposite direction of motor shaft	Lead out in direction of motor shaft	Lead out in opposite direction of motor shaft		
HG Series	HG96	10040 16040 16040S	- All axes CNU01SEF(AWG14) - L-axis only CNU01SEL(AWG14) - M-axis only CNU01SEM(AWG14) - S-axis only CNU01SES(AWG14)	MR-PWS1CBL □ M-A1-H □ : Length (m) 2, 3, 5, 7, 10	MR-PWS1CBL □ M-A2-H □ : Length (m) 2, 3, 5, 7, 10	MR-BKS1CBL □ M-A1-H □ : Length (m) 2, 3, 5, 7, 10	MR-BKS1CBL □ M-A2-H □ : Length (m) 2, 3, 5, 7, 10

Servo motor type	Drive unit type MDS-EM-SPV3	Power Connector		Brake Connector		
		Drive unit side	Motor side		Motor side	
			Straight	Right angle	Straight	Right angle
HG Series	HG75□-S105010 HG105□-S105010 HG75 HG105 HG123 HG142 HG54 HG104 HG223	10040 16040 16040S	CNP14-2S (12) Applicable cable outline ø10 to 12 (mm)	CNP14-2L (12) Applicable cable outline ø10 to 12 (mm)	CNP10-R2S (6) CNP10S-R2S (6) Applicable cable outline ø4.0 to 6.0 (mm)	CNP10-R2L (6) CNP10S-R2L (6) Applicable cable outline ø4.0 to 6.0 (mm)
	HG302	10040 10080 16040 16080 20080	CNP18-10S (14) Applicable cable outline ø10.5 to 14 (mm)	CNP18-10L (14) Applicable cable outline ø10.5 to 14 (mm)		
	HG154 HG224 HG204 HG303 HG354 HG453	10080 16080 20080 200120 320120	CNP22-22S (16) Applicable cable outline ø12.5 to 16 (mm)	CNP22-22L (16) Applicable cable outline ø12.5 to 16 (mm)		
	HG702	200120 320120	CNP18-10S (14) Applicable cable outline ø10.5 to 14 (mm)	CNP18-10L (14) Applicable cable outline ø10.5 to 14 (mm)		
			CNP22-22S (16) Applicable cable outline ø12.5 to 16 (mm)	CNP22-22S (16) Applicable cable outline ø12.5 to 16 (mm)		
			CNP32-17S (23) Applicable cable outline ø22 to 23.8 (mm)	CNP32-17L (23) Applicable cable outline ø22 to 23.8 (mm)		

■MDS-EM Series Encoder Cable and Connector for Servo Motor Selection List

Servo motor type	Drive unit type MDS-EM-SPV3	Servo encoder cable									
		Motor side encoder cable				Ball screw side encoder cable					
		Cable (for D47/D48/D51)		Single connector		Ball screw side encoder (OSA405ET2AS)		Single connector			
		Straight	Right angle	Drive unit side	Motor side	Straight	Right angle	Straight	Right angle		
HG Series	HG96 HG75 HG105 HG123 HG142 HG54 HG104 HG223 HG302 HG154 HG224 HG204 HG303 HG354 HG453 HG702	10040 16040 16040S	CNV2E-8P-□M □ : Length (m) 2, 3, 4, 5, 7, 10, 15, 20, 25, 30	CNV2E-9P-□M □ : Length (m) 2, 3, 4, 5, 7, 10, 15, 20, 25, 30	CNU2S (AWG18)	CNE10-R10S (9) CNE10S-R10S (9) Applicable cable outline ø6.0 to 9.0 (mm)	CNE10-R10L (9) CNE10S-R10L (9) Applicable cable outline ø6.0 to 9.0 (mm)	CNV2E-8P-□M □ : Length (m) 2, 3, 4, 5, 7, 10, 15, 20, 25, 30	CNV2E-9P-□M □ : Length (m) 2, 3, 4, 5, 7, 10, 15, 20, 25, 30	CNE10-R10S (9) CNE10S-R10S (9) Applicable cable outline ø6.0 to 9.0 (mm)	CNE10-R10L (9) CNE10S-R10L (9) Applicable cable outline ø6.0 to 9.0 (mm)

■MDS-EM Series Power Connector, Encoder Cable, and Connector for Spindle Motor Selection List

Spindle motor type	Drive unit type MDS-EM-SPV3	Power Connector		Spindle encoder cable											
		Drive unit side	Motor side	When connecting to a spindle motor		When connecting to a spindle side encoder									
		Motor side PLG cable		Spindle side accuracy encoder TS5690 cable		Spindle side encoder OSE-1024 cable									
		Cable	Single connector	Cable	Single connector	Cable		Single connector							
		Drive unit side	Encoder side	Drive unit side	Encoder side	Straight	Right angle	Drive unit side	Encoder side	Straight	Right angle				
SJ-D Series (Normal)	SJ-D5.5/100-01 SJ-D5.5/120-01	10040 10080 16040S													
	SJ-D5.5/120-02	10040 10080 16040 16080 16040S 20080 200120													
	SJ-D7.5/100-01 SJ-D7.5/120-01	10040 10080 16040S													
	SJ-D11/100-01	16040 16080 16040S													
	SJ-D15/80-01	20080 200120													
	SJ-D18.5/80-01	320120													
	SJ-D22/80-01	320120													
	SJ-D26/80-01	320120													
	SJ-D Series (Hollow shaft)	SJ-D5.5/120-02T-S	10040 10080 16040 16080 16040S 20080 200120												
		SJ-DG3.7/120-03T	10040 10080 16040S												
SJ-DG Series (High output)	SJ-DG5.5/120-04T SJ-DG7.5/120-05T SJ-DG11/100-03T	16040 16080 16040S													
	SJ-DG11/100-03T	16040 16080 16040S 20080 200120													
	SJ-DG15/120-02T-K	20080 200120													
	SJ-DJ5.5/100-01 SJ-DJ5.5/120-01 SJ-DJ7.5/100-01 SJ-DJ7.5/120-01	10040 10080 16040S													
	SJ-DJ11/100-01 SJ-DJ15/80-01	16040 16080 16040S 20080 200120													
	SJ-DL3.7/240-01T	20080 200120													
SJ-DL Series (Low-inertia)	SJ-DL5.5/150-01T SJ-DL5.5/240-05T	16040 16080 16040S 20080 200120													
	SJ-DL7.5/150-01T	16040 16080 16040S													
	SJ-DN7.5/80-01	10040 10080 16040S													
SJ-DN Series (High-torque specifications)	SJ-DN11/80-01 SJ-DN15/80-01 SJ-DN18.5/80-01	20080 200120													
	SJ-V15-09ZT SJ-V18.5-01ZT	20080 200120													
	SJ-V11-01T SJ-V11-09T	16040 16080 16040S													
SJ-V Series (Wide range constant output)	SJ-V15-03T	20080 200120													
	SJ-VL11-02FZT SJ-VL11-05FZT-S01	16040 16080 16040S													

■MDS-EJ Series Power Cable/Connector and Brake Cable/Connector for Servo Motor Selection List

Servo motor type	Drive unit type MDS-EJ- V1	Drive unit type MDS-EJ- V2	Power Cable		Brake Cable		
			Single connector	Cable	Single connector	Cable	
			Drive unit side	Motor side		Motor side	
			Lead out in direction of motor shaft	Lead out in opposite direction of motor shaft	Lead out in direction of motor shaft	Lead out in opposite direction of motor shaft	
HG Series	HG46	10	—	MR-PWS1CBL □ M-A1-H	MR-PWS1CBL □ M-A2-H	MR-BKS1CBL □ M-A1-H	MR-BKS1CBL □ M-A2-H
	HG56	15	—	□ : Length (m) 2, 3, 5, 7, 10	□ : Length (m) 2, 3, 5, 7, 10	□ : Length (m) 2, 3, 5, 7, 10	□ : Length (m) 2, 3, 5, 7, 10
	HG96	30	30				

Servo motor type	Drive unit type MDS-EJ- V1	Drive unit type MDS-EJ- V2	Power Connector		Brake Connector			
			Drive unit side	Motor side		Motor side		
				Straight	Right angle	Straight	Right angle	
HG Series	HG75□-S105010	30	30	Supplied for each drive unit	CNP14-2S (12) Applicable cable outline ø10 to 12 (mm)	CNP14-2L (12) Applicable cable outline ø10 to 12 (mm)	CNP10-R2S (6) CNP10S-R2S (6) Applicable cable outline ø4.0 to 6.0 (mm)	CNP10-R2L (6) CNP10S-R2L (6) Applicable cable outline ø4.0 to 6.0 (mm)
	HG105□-S105010				CNP18-10S (14) Applicable cable outline ø10.5 to 14 (mm)	CNP18-10L (14) Applicable cable outline ø10.5 to 14 (mm)		
	HG75				CNP22-22S (16) Applicable cable outline ø12.5 to 16 (mm)	CNP22-22L (16) Applicable cable outline ø12.5 to 16 (mm)		
	HG105				CNP18-10S (14) Applicable cable outline ø10.5 to 14 (mm)	CNP18-10L (14) Applicable cable outline ø10.5 to 14 (mm)		
	HG54				CNP22-22S (16) Applicable cable outline ø12.5 to 16 (mm)	CNP22-22L (16) Applicable cable outline ø12.5 to 16 (mm)		
	HG104	40	40		CNP18-10S (14) Applicable cable outline ø10.5 to 14 (mm)	CNP18-10L (14) Applicable cable outline ø10.5 to 14 (mm)		
	HG123				CNP22-22S (16) Applicable cable outline ø12.5 to 16 (mm)	CNP22-22L (16) Applicable cable outline ø12.5 to 16 (mm)		
	HG142				CNP18-10S (14) Applicable cable outline ø10.5 to 14 (mm)	CNP18-10L (14) Applicable cable outline ø10.5 to 14 (mm)		
	HG223				CNP22-22S (16) Applicable cable outline ø12.5 to 16 (mm)	CNP22-22L (16) Applicable cable outline ø12.5 to 16 (mm)		
	HG302				CNP18-10S (14) Applicable cable outline ø10.5 to 14 (mm)	CNP18-10L (14) Applicable cable outline ø10.5 to 14 (mm)		
	HG154	80	—		CNP22-22S (16) Applicable cable outline ø12.5 to 16 (mm)	CNP22-22L (16) Applicable cable outline ø12.5 to 16 (mm)		
	HG224				CNP18-10S (14) Applicable cable outline ø10.5 to 14 (mm)	CNP18-10L (14) Applicable cable outline ø10.5 to 14 (mm)		
	HG204				CNP22-22S (16) Applicable cable outline ø12.5 to 16 (mm)	CNP22-22L (16) Applicable cable outline ø12.5 to 16 (mm)		
	HG303				CNP18-10S (14) Applicable cable outline ø10.5 to 14 (mm)	CNP18-10L (14) Applicable cable outline ø10.5 to 14 (mm)		
	HG354				CNP22-22S (16) Applicable cable outline ø12.5 to 16 (mm)	CNP22-22L (16) Applicable cable outline ø12.5 to 16 (mm)		

■MDS-EJ Series Encoder Cable and Connector for Servo Motor Selection List

Servo motor type	Drive unit type MDS-EJ- V1	Drive unit type MDS-EJ- V2	Servo encoder cable									
			Motor side encoder cable				Ball screw side encoder cable					
			Cable (for D47/D48/D51)		Single connector		Cable		Single connector			
			Straight	Right angle	Drive unit side	Motor side	Straight	Right angle	Straight	Right angle		
HG Series	HG46	10	—	CNP2E-8P-□M □ : Length (m) 2, 3, 4, 5, 7, 10, 15, 20, 25, 30	CNP2E-9P-□M □ : Length (m) 2, 3, 4, 5, 7, 10, 15, 20, 25, 30	CNU2S (AWG18)	CNE10-R10S (9) CNE10S-R10S (9) Applicable cable outline ø6.0 to 9.0 (mm)	CNE10-R10L (9) CNE10S-R10L (9) Applicable cable outline ø6.0 to 9.0 (mm)	CNP2E-8P-□M □ : Length (m) 2, 3, 4, 5, 7, 10, 15, 20, 25, 30	CNP2E-9P-□M □ : Length (m) 2, 3, 4, 5, 7, 10, 15, 20, 25, 30	CNE10-R10S (9) CNE10S-R10S (9) Applicable cable outline ø6.0 to 9.0 (mm)	CNE10-R10L (9) CNE10S-R10L (9) Applicable cable outline ø6.0 to 9.0 (mm)
	HG56	15	—									
	HG96	30	30									
	HG75	40	40									
	HG105											
	HG54											
	HG104											
	HG123											
	HG142	80	—									
	HG223											
	HG302											
	HG154											
	HG224											
	HG204	100	—									
	HG303											
HG354												

■MDS-EJ Series Power Connector, Encoder Cable, and Connector for Spindle Motor Selection List

Spindle motor type	Drive unit type MDS-EJ- SP	Power Cable		Spindle encoder cable									
		When connecting to a spindle motor		When connecting to a spindle motor				When connecting to a spindle side encoder					
		Drive unit side	Motor side	Motor side PLG cable		Spindle side accuracy encoder TS5690 cable		Spindle side encoder OSE-1024 cable					
				Cable	Single connector	Cable	Single connector	Cable	Single connector				
SJ-D Series (Normal)	SJ-D3.7/100-01	80	Supplied for each drive unit										
	SJ-D5.5/100-01	100											
	SJ-D5.5/120-01												
	SJ-D7.5/100-01	120											
	SJ-D7.5/120-01												
SJ-D11/100-01	160	Terminal block connection	Terminal block connection	CNP2E-1□M □ : Length (m) 2, 3, 4, 5, 7, 10, 15, 20, 25, 30	CNU2S (AWG18)	CNEPGS	CNP2E-1□M □ : Length (m) 2, 3, 4, 5, 7, 10, 15, 20, 25, 30	CNU2S (AWG18)	CNEPGS	CNP3EZ-2P-□M □ : Length (m) 2, 3, 4, 5, 7, 10, 15, 20, 25, 30	CNP3EZ-3P-□M □ : Length (m) 2, 3, 4, 5, 7, 10, 15, 20, 25, 30	CNE20-29S (10) Applicable cable outline ø6.8 to 10 (mm)	CNE20-29L (10) Applicable cable outline ø6.8 to 10 (mm)
SJ-DJ5.5/100-01	100	Terminal block connection											
SJ-DJ5.5/120-01	120												
SJ-DJ7.5/100-01													
SJ-DJ11/100-01	160												

■MDS-EH Series Power Connector and Brake Connector for Servo Motor Selection List

Servo motor type	Drive unit type MDS-EH-			Power Connector				Brake Connector				
	V1	V2	V3	Drive unit side	Motor side		Drive unit side	Motor side		Drive unit side	Motor side	
					Straight	Right angle		Straight	Right angle			
HG-H Series	HG-H75□-S105010	10	10 20	—	- All axes CNU01SEF (AWG14) - L-axis only CNU01SEL (AWG14) - M-axis only CNU01SEM (AWG14) - S-axis only CNU01SES (AWG14)	CNP14-2S (12)	CNP14-2L (12)	CNU23S (AWG14)	CNB10-R2S (6) CNB10S-R2S (6) Applicable cable outline ø4.0 to 6.0 (mm)	CNB10-R2L (6) CNB10S-R2L (6) Applicable cable outline ø4.0 to 6.0 (mm)	Applicable cable outline	Applicable cable outline
	HG-H105□-S105010					ø10 to 12 (mm)	ø10 to 12 (mm)					
	HG-H75					ø10 to 12 (mm)	ø10 to 12 (mm)					
	HG-H105	20	20 40	40		CNP18-10S (14)	CNP18-10L (14)				Applicable cable outline	Applicable cable outline
	HG-H54					ø10.5 to 14 (mm)	ø10.5 to 14 (mm)					
	HG-H104					ø10.5 to 14 (mm)	ø10.5 to 14 (mm)					
	HG-H154	40	40 80	40		CNP22-22S (16)	CNP22-22L (16)				Applicable cable outline	Applicable cable outline
	HG-H224					ø12.5 to 16 (mm)	ø12.5 to 16 (mm)					
	HG-H204					ø12.5 to 16 (mm)	ø12.5 to 16 (mm)					
	HG-H354	80	80 80W	—		CNP32-17S (23)	CNP32-17L (23)				Applicable cable outline	Applicable cable outline
HG-H453	ø22 to 23.8 (mm)				ø22 to 23.8 (mm)							
HG-H703	ø22 to 23.8 (mm)				ø22 to 23.8 (mm)							
HG-H903	160	160	—	Terminal block connection	Terminal block connection							
HG-H1502	200	—		Terminal block connection	Terminal block connection							
HQ-H Series	HQ-H903	160	160	—	CNP32-17S (23)	CNP32-17L (23)	Applicable cable outline	Applicable cable outline				
	HQ-H1103	160W	—		ø22 to 23.8 (mm)	ø22 to 23.8 (mm)						

■MDS-EH Series Power Connector for Spindle Motor Selection List

Spindle motor type	Drive unit type MDS-EH-SP	Power Connector	
		Drive unit side	Motor side
SJ-4-V Series (Normal)	SJ-4-V2.2-03T	- All axes CNU01SEF (AWG14) - L-axis only CNU01SEL (AWG14)	Terminal block connection
	SJ-4-V3.7-03T		
	SJ-4-V5.5-07T		
	SJ-4-V7.5-12T		
	SJ-4-V7.5-13ZT		
	SJ-4-V11-18T		
	SJ-4-V18.5-14T		
	SJ-4-V22-18ZT		
	SJ-4-V22-15T		
	SJ-4-V26-08ZT		
SJ-4-V Series (Wide range constant output)	SJ-4-V15-20T		
	SJ-4-V22-16T		
	SJ-4-V37-04ZT		

■MDS-EH Series Encoder Cable and Connector for Spindle Motor Selection List

Spindle motor type	Drive unit type MDS-EH-SP	Spindle encoder cable										
		When connecting to a spindle motor				When connecting to a spindle side encoder						
		Motor side PLG cable		Spindle side accuracy encoder TS5690 cable		Spindle side encoder OSE-1024 cable						
		Cable	Single connector	Cable	Single connector	Cable		Single connector				
				Straight	Right angle	Drive unit side	Encoder side					
							Straight	Right angle				
SJ-4-V Series (Normal)	SJ-4-V2.2-03T	CNP2E-1-□M □ : Length (m) 2, 3, 4, 5, 7, 10, 15, 20, 25, 30	CNU2S (AWG18)	CNEPGS	CNP2E-1-□M □ : Length (m) 2, 3, 4, 5, 7, 10, 15, 20, 25, 30	CNU2S (AWG18)	CNEPGS	CNP3EZ-2P-□M □ : Length (m) 2, 3, 4, 5, 7, 10, 15, 20, 25, 30	CNP3EZ-3P-□M □ : Length (m) 2, 3, 4, 5, 7, 10, 15, 20, 25, 30	CNEPGS	CNE20-29S (10) Applicable cable outline ø6.8 to 10 (mm)	CNE20-29L (10) Applicable cable outline ø6.8 to 10 (mm)
	SJ-4-V3.7-03T											
	SJ-4-V5.5-07T											
	SJ-4-V7.5-12T											
	SJ-4-V7.5-13ZT											
	SJ-4-V11-18T											
	SJ-4-V18.5-14T											
	SJ-4-V22-18ZT											
	SJ-4-V22-15T											
	SJ-4-V26-08ZT											
	SJ-4-V37-04ZT											
	SJ-4-V45-02T											
	SJ-4-V55-03T											
SJ-4-V Series (Wide range constant output)	SJ-4-V15-20T											
	SJ-4-V22-16T											

■MDS-EH Series Encoder Cable and Connector for Servo Motor Selection List

Servo motor type	Servo encoder cable														
	Motor side encoder cable						Ball screw side encoder cable								
	Cable (for D48/D51/D74)			Single connector			Ball screw side encoder (OSA405ET2AS/OSA676ET2AS)								
	V1	V2	V3	Straight	Right angle	Drive unit side	Motor side		Straight	Right angle	Straight	Right angle			
Straight							Right angle								
HG Series	HG-H75	10	10 20	—	CNV2E-8P-□M □ : Length (m) 2, 3, 4, 5, 7, 10, 15, 20, 25, 30	CNV2E-9P-□M □ : Length (m) 2, 3, 4, 5, 7, 10, 15, 20, 25, 30	CNU2S (AWG18)	CNE10-R10S (9) CNE10S-R10S (9) Applicable cable outline ø6.0 to 9.0 (mm)	CNE10-R10L (9) CNE10S-R10L (9) Applicable cable outline ø6.0 to 9.0 (mm)	CNE10-R10S (9) CNE10S-R10S (9) Applicable cable outline ø6.0 to 9.0 (mm)	CNE10-R10L (9) CNE10S-R10L (9) Applicable cable outline ø6.0 to 9.0 (mm)				
	HG-H105														
	HG-H75														
	HG-H54	20	20 40	40								CNE10-R10S (9)	CNE10-R10L (9)	Applicable cable outline	Applicable cable outline
	HG-H104											ø6.0 to 9.0 (mm)	ø6.0 to 9.0 (mm)		
	HG-H154											ø6.0 to 9.0 (mm)	ø6.0 to 9.0 (mm)		
	HG-H224	40	40 80	40								CNE10-R10S (9)	CNE10-R10L (9)	Applicable cable outline	Applicable cable outline
	HG-H204											ø6.0 to 9.0 (mm)	ø6.0 to 9.0 (mm)		
	HG-H354											ø6.0 to 9.0 (mm)	ø6.0 to 9.0 (mm)		
	HG-H453	80	80 80W	—								CNE10-R10S (9)	CNE10-R10L (9)	Applicable cable outline	Applicable cable outline
HG-H703	ø6.0 to 9.0 (mm)				ø6.0 to 9.0 (mm)										
HG-H903	ø6.0 to 9.0 (mm)				ø6.0 to 9.0 (mm)										
HG-H1502	200	—	—	Terminal block connection	Terminal block connection										
HQ Series	HQ-H903	160		160	Terminal block connection	Terminal block connection									
	HQ-H1103	160W	—	Terminal block connection	Terminal block connection										

■MDS-EMH Series Power Connector and Brake Connector for Servo Motor Selection List

Servo motor type	Drive unit type MDS-EMH- SPV3	Power Connector				Brake Connector	
		Drive unit side	Motor side		Motor side		
			Straight	Right angle	Straight	Right angle	
HG-H Series	HG-H54	8040 10040	- All axes CNU01SEF (AWG14) - L-axis only CNU01SEL (AWG14) - M-axis only CNU01SEM (AWG14) - S-axis only CNU01SES (AWG14)	CNP18-10S (14)	CNP18-10L (14)	CNB10-R2S (6) CNB10S-R2S (6)	CNB10-R2L (6) CNB10S-R2L (6)
	HG-H104			Applicable cable outline ø10.5 to 14 (mm)	Applicable cable outline ø10.5 to 14 (mm)		
	HG-H154	8040		CNP22-22S (16)	CNP22-22L (16)	Applicable cable outline ø12.5 to 16 (mm)	Applicable cable outline ø12.5 to 16 (mm)
	HG-H204	10040		Applicable cable outline ø12.5 to 16 (mm)	Applicable cable outline ø12.5 to 16 (mm)		
	HG-H354	10060					
	HG-H453						

■MDS-EMH Series Encoder Cable and Connector for Servo Motor Selection List

Servo motor type	Drive unit type MDS-EMH- SPV3	Servo encoder cable									
		Motor side encoder cable					Ball screw side encoder cable				
		Cable (for D48/D51)		Single connector			Ball screw side encoder (OSA405ET2AS)				
		Straight	Right angle	Drive unit side	Motor side		Cable		Single connector		
HG-H Series	HG-H54	8040 10040	CNV2E-8P-□M	CNV2E-9P-□M	CNU2S (AWG18)	CNE10-R10S (9)	CNE10-R10L (9)	CNV2E-8P-□M	CNV2E-9P-□M	CNE10-R10S (9)	CNE10-R10L (9)
	HG-H104					CNE10S-R10S (9)	CNE10S-R10L (9)			CNE10S-R10S (9)	CNE10S-R10L (9)
	HG-H154	8040	□ : Length (m)	□ : Length (m)		□ : Length (m)	□ : Length (m)	CNE10S-R10S (9)	CNE10S-R10L (9)	CNE10S-R10S (9)	CNE10S-R10L (9)
	HG-H204	10040	2, 3, 4, 5, 7, 10, 15, 20, 25, 30	2, 3, 4, 5, 7, 10, 15, 20, 25, 30		2, 3, 4, 5, 7, 10, 15, 20, 25, 30	2, 3, 4, 5, 7, 10, 15, 20, 25, 30	Applicable cable outline ø6.0 to 9.0 (mm)	Applicable cable outline ø6.0 to 9.0 (mm)	Applicable cable outline ø6.0 to 9.0 (mm)	Applicable cable outline ø6.0 to 9.0 (mm)
	HG-H354	10060									

■MDS-EMH Series Power Connector, Encoder Cable, and Connector for Spindle Motor Selection List

Servo motor type	Drive unit type MDS-EMH- SPV3	Power Cable		Spindle encoder cable															
		Drive unit side	Motor side	When connecting to a spindle motor				When connecting to a spindle side encoder											
				Motor side PLG cable		Spindle side accuracy encoder TS5690 cable		Spindle side encoder OSE-1024 cable											
		Cable	Single connector	Cable	Single connector	Cable		Single connector											
SJ-4-V Series (Normal)	SJ-4-V7.5-13ZT	Terminal block connection	Terminal block connection	CNP2E-1-□M	□ : Length (m)	CNU2S (AWG18)	CNEPGS	CNP2E-1-□M	□ : Length (m)	CNU2S (AWG18)	CNEPGS	CNP3EZ-2P-□M	CNP3EZ-3P-□M	CNE20-29S (10)	CNE20-29L (10)				
	SJ-4-V11-18T															2, 3, 4, 5, 7, 10, 15, 20, 25, 30	2, 3, 4, 5, 7, 10, 15, 20, 25, 30	2, 3, 4, 5, 7, 10, 15, 20, 25, 30	2, 3, 4, 5, 7, 10, 15, 20, 25, 30
	SJ-4-V18.5-14T																		
SJ-4-V Series (Wide range constant output)	SJ-4-V15-20T																		

■MDS-EJH Series Power Connector and Brake Connector for Servo Motor Selection List

Servo motor type	Drive unit type MDS-EJH- V1	Power Connector				Brake Connector	
		Drive unit side	Motor side		Motor side		
			Straight	Right angle	Straight	Right angle	
HG-H Series	HG-H75□-S105010	Supplied for each drive unit	CNP14-2S (12)	CNP14-2L (12)	CNB10-R2S (6) CNB10S-R2S (6)	CNB10-R2L (6) CNB10S-R2L (6)	
	HG-H105□-S105010		Applicable cable outline ø10 to 12 (mm)	Applicable cable outline ø10 to 12 (mm)			Applicable cable outline ø4.0 to 6.0 (mm)
	HG-H75		15	CNP18-10S (14)	CNP18-10L (14)	Applicable cable outline ø4.0 to 6.0 (mm)	Applicable cable outline ø4.0 to 6.0 (mm)
	HG-H105		20	Applicable cable outline ø10.5 to 14 (mm)	Applicable cable outline ø10.5 to 14 (mm)		
	HG-H54						
	HG-H104						
HG-H154	40						

■MDS-EJH Series Encoder Cable and Connector for Servo Motor Selection List

Servo motor type	Drive unit type MDS-EJH- V1	Servo encoder cable									
		Motor side encoder cable					Ball screw side encoder cable				
		Cable (for D48/D51)		Single connector			Ball screw side encoder (OSA405ET2AS)				
		Straight	Right angle	Drive unit side	Motor side		Cable		Single connector		
HG-H Series	HG-H75	CNV2E-8P-□M	CNV2E-9P-□M	CNU2S (AWG18)	CNE10-R10S (9)	CNE10-R10L (9)	CNV2E-8P-□M	CNV2E-9P-□M	CNE10-R10S (9)	CNE10-R10L (9)	
	HG-H105				CNE10S-R10S (9)	CNE10S-R10L (9)			CNE10S-R10S (9)	CNE10S-R10L (9)	
	HG-H54	8040	□ : Length (m)		□ : Length (m)	□ : Length (m)	□ : Length (m)	Applicable cable outline ø6.0 to 9.0 (mm)	Applicable cable outline ø6.0 to 9.0 (mm)	Applicable cable outline ø6.0 to 9.0 (mm)	Applicable cable outline ø6.0 to 9.0 (mm)
	HG-H104	10040	2, 3, 4, 5, 7, 10, 15, 20, 25, 30		2, 3, 4, 5, 7, 10, 15, 20, 25, 30	2, 3, 4, 5, 7, 10, 15, 20, 25, 30	2, 3, 4, 5, 7, 10, 15, 20, 25, 30	Applicable cable outline ø6.0 to 9.0 (mm)	Applicable cable outline ø6.0 to 9.0 (mm)	Applicable cable outline ø6.0 to 9.0 (mm)	Applicable cable outline ø6.0 to 9.0 (mm)
	HG-H154	10060									

LIST OF CABLES

[Manufacturer (Column and figure on the left show drive unit side.)]

a : Honda Tsushin Kogyo b : Japan Aviation Electronics Industry c : Hirose Electric d : 3M e : J.S.T. f : DDK g : Tyco Electronics

<Optical communication cable>

Item	Model	Length (m)	Contents	Manu- facturer	Compatible model				
					E/EH	EM/EMH	EJ/EJH		
For CN1A/ CN1B/ OPT1A	Optical communication cable For wiring between drive units (inside panel)	J396 L0.3M	0.3		a	a	○	○	○
		J396 L0.5M	0.5						
		J396 L1M	1						
		J396 L2M	2						
		J396 L3M	3						
	Optical communication cable For wiring between drive units (outside panel)	J396 L5M	5		a	a	○	○	○
		J395 L3M	3						
		J395 L5M	5						
		J395 L7M	7						
		J395 L10M	10						
Optical communication cable For wiring between drive units (outside panel)	G380 L5M G380 L10M G380 L12M G380 L15M G380 L20M G380 L25M G380 L30M	5		g	g	○	○	○	
		10							
		12							
		15							
		20							
		25							
30									

(Note1) For details on the optical communication cable, refer to the section "Optical communication cable specification" in Specifications Manual of each drive unit.

<Battery cable and connector>

Item	Model	Length (m)	Contents	Manu- facturer	Compatible model				
					E/EH	EM/EMH	EJ/EJH		
For drive unit	Battery cable (For drive unit - battery box, For drive unit - drive unit)	DG30-0.3M	0.3		e	e	○	○	○
		DG30-0.5M	0.5						
		DG30-1M	1.0						
		DG30-2M	2.0						
		DG30-3M	3.0						
		DG30-5M	5.0						
		DG30-7M	7.0						
		DG30-10M	10.0						
Battery cable	MR-BT6V2CBL0.3M	0.3		e	e	-	-	○	
	MR-BT6V2CBL1M	1							

(Note1) For MDS-EJ/EJH, drive unit - drive unit connection is not available.

<Power supply communication cable and connector>

Item	Model	Length (m)	Contents	Manu- facturer	Compatible model				
					E/EH	EM/EMH	EJ/EJH	EX-CVP	
For CN4/9	Power supply communication cable	0.35		d	d	○	-	-	○
		0.5							
		1							
		2							
Power supply communication cable connector set	FCUA-CS000	-		d	d	○	-	-	○
		3							
For CN23	Contacter control output connector Applicable cable outline: 0.85mm ² to 3.5mm ² Finish outside diameter: to ø4.2mm	-		e	e	○	-	-	○
For CN24	External emergency stop input connector	-		f	f	○	-	-	○
For CN48	Connector for detecting power supply phase Applicable cable outline: 0.8mm ² to 2.1mm ² Finish outside diameter: to ø3.9mm	-		e	e	-	-	-	○

<Power backup unit connector>

Item	Model	Length (m)	Contents	Manu- facturer	Compatible model		
					D-PFU	DH-PFU	
For CN43	Input/output connector for power backup unit	-		f	f	○	○
For TE1	Power connector for power backup unit	-		e	e	○	○





<STO input connector>



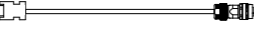

Item	Model	Length (m)	Contents	Manu- facturer	Compatible model			
					E/EH	EM/EMH	EJ/EJH	
For CN8	STO cable	-		g	g	○	-	○
STO short-circuit connector	These connectors are supplied for each drive unit.	-		b	b	○	-	○

<DI/O analog output connector>







Item	Model	Length (m)	Contents	Manu- facturer	Compatible model			
					E/EH	EM/EMH	EJ/EJH	
For CN9	DI/O analog output connector (MDS-E/EH,EM/EMH,EJ/EJH-V1/EJ-SP)	-		d	d	○	○	○
DI/O analog output connector (MDS-EJ-V2/SP2)	FCUA-DJ200	-		d	d	-	-	○

<Servo motor/Tool spindle motor cable and connector>

















Item	Model	Length (m)	Contents	Manu- facturer	Compatible model			
					E/EH	EM/EMH	EJ/EJH	
For CN2/3 For CN3L/ CN3M/ CN3S	CNV2E-8P-2M	2		d	f	○	○	○
	CNV2E-8P-3M	3						
	CNV2E-8P-4M	4						
	CNV2E-8P-5M	5						
	CNV2E-8P-7M	7						
	CNV2E-8P-10M	10						
	CNV2E-8P-15M	15						
	CNV2E-8P-20M	20						
	CNV2E-8P-25M	25						
	CNV2E-8P-30M	30						
	CNV2E-9P-2M	2						
	CNV2E-9P-3M	3						
	CNV2E-9P-4M	4						
	CNV2E-9P-5M	5						
	CNV2E-9P-7M	7						
CNV2E-9P-10M	10							
CNV2E-9P-15M	15							
CNV2E-9P-20M	20							
CNV2E-9P-25M	25							
CNV2E-9P-30M	30							
For motor encoder/ Ball screw side encoder	CNE10-R10S(9)	-		f	○	○	○	○
	CNE10-R10L(9)	-		f	○	○	○	○
	CNE10S-R10S(9)	-		f	○	○	○	○
	CNE10S-R10L(9)	-		f	○	○	○	○

Item	Model	Length (m)	Contents	Manu- facturer	Compatible model			
					E/EH	EM/EMH	EJ/EJH	
CN3	CNV2E-HP-2M	2		d	c	○	○	○
	CNV2E-HP-3M	3						
	CNV2E-HP-4M	4						
	CNV2E-HP-5M	5						
	CNV2E-HP-7M	7						
	CNV2E-HP-10M	10						
	CNV2E-HP-15M	15						
	CNV2E-HP-20M	20						
	CNV2E-HP-25M	25						
	CNV2E-HP-30M	30						
	For MDS- EX-HR/ MDS-B- HR unit	CNEHRS(10)						
For CN3	CNV2E-D-2M	2		d	d	○	-	-
	CNV2E-D-3M	3						
	CNV2E-D-4M	4						
	CNV2E-D-5M	5						
	CNV2E-D-7M	7						
	CNV2E-D-10M	10						
	CNV2E-D-15M	15						
	CNV2E-D-20M	20						
CNV2E-D-25M	25							
CNV2E-D-30M	30							
For MDS- B-SD unit	FCUA-CS000	-		d	d	○	-	-
For CN2/3	CNU2S(AWG18)	-		d	○	○	○	○

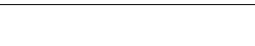
<Brake cable and connector>

Item	Model	Length (m)	Contents	Manu- facturer	Compatible model		
					E/EH	EM/EMH	EJ/EJH
For motor brake	CNB10-R2S(6)	-		f	○	○	○
	CNB10-R2L(6)	-		f	○	○	○
	CNB10S-R2S(6)	-		f	○	○	○
	CNB10S-R2L(6)	-		f	○	○	○
For motor brake	MR-BKS1CBL 2M-A1-H	2		b	○	○	○
	MR-BKS1CBL 3M-A1-H	3					
	MR-BKS1CBL 5M-A1-H	5					
	MR-BKS1CBL 7M-A1-H	7					
	MR-BKS1CBL 10M-A1-H	10					
For motor brake	MR-BKS1CBL 2M-A2-H	2		b	○	○	○
	MR-BKS1CBL 3M-A2-H	3					
	MR-BKS1CBL 5M-A2-H	5					
	MR-BKS1CBL 7M-A2-H	7					
MR-BKS1CBL 10M-A2-H	10						
For CN20	CNU23S(AWG14)	-		f	○	-	-

<Power connector>

Item	Model	Length (m)	Contents	Manu- facturer	Compatible model		
					E/EH	EM/EMH	EJ/EJH
For motor power	CNP18-10S(14)	-		f	○	○	○
	CNP18-10L(14)	-		f	○	○	○
	CNP22-22S(16)	-		f	○	○	○
	CNP22-22L(16)	-		f	○	○	○
	CNP32-17S(23)	-		f	○	○	-
	CNP32-17L(23)	-		f	○	○	-
	CNP14-2S(12)	-		f	○	○	○
	CNP14-2L(12)	-		f	○	○	○
	MR-PWS1CBL 2M-A1-H	2		b	○	-	○
	MR-PWS1CBL 3M-A1-H	3					
MR-PWS1CBL 5M-A1-H	5		b	○	-	○	
MR-PWS1CBL 7M-A1-H	7						
MR-PWS1CBL 10M-A1-H	10		b	○	-	○	
MR-PWS1CBL 2M-A2-H	2						
MR-PWS1CBL 3M-A2-H	3		b	○	-	○	
MR-PWS1CBL 5M-A2-H	5						
MR-PWS1CBL 7M-A2-H	7		b	○	-	○	
MR-PWS1CBL 10M-A2-H	10						
For TE1	CNU01SEF(AWG14)	-		e	○	-	-
	CNU01SEL(AWG14)	-					
	CNU01SEM(AWG14)	-					
	CNU01SES(AWG14)	-					
For TE1	CNU01SECV(AWG14)	-		e	○	-	-
	CNU01SECV(AWG14)	-					
For CN31 L/M/S	CNU01SEF(AWG14)	-		e	-	○	-
	CNU01SEL(AWG14)	-					
For CN22	RCN22	-		f	-	○	-
	RCN22S	-					

<Drive unit side main circuit connector>

Item	Model	Length (m)	Contents	Manu- facturer	Compatible model			
					E/EH	EM/EMH	EJ/EJH	
For drive unit	<200V series> For MDS-EJ-V1-10, 15, 30 For MDS-EJ-SP-20 Applicable cable outline: 0.8mm ² to 2.1mm ² Finish outside diameter: to ø3.9mm	-		e	-	-	○	
		-		e	-	-	○	
		-		e	-	-	○	
		-		e	-	-	○	
	<200V series> For MDS-EJ-V1-40, 80 For MDS-EJ-V2-40 Applicable cable outline: (For CNP1, for CNP3/CNP3L/CNP3M) 1.25mm ² to 5.5mm ² (For CNP2) 0.14mm ² to 2.1mm ² Finish outside diameter: (For CNP1, for CNP3/CNP3L/CNP3M) to ø4.7mm (For CNP2) to ø3.9mm ²	-		e	-	-	○	
		-		e	-	-	○	
		-		e	-	-	○	
		-		e	-	-	○	
	<200V series> For MDS-EJ-V2-30 For MDS-EJ-SP2-20	These connectors are supplied for each drive unit.	-		e	-	-	○
			-		e	-	-	○
			-		e	-	-	○
			-		e	-	-	○
<400V series> For MDS-EJH-V1-10,15,20,40 Applicable cable outline:0.8mm ² to 2.1mm ² Finish outside diameter: to ø3.9mm	These connectors are supplied for each drive unit.	-		e	-	-	○	
		-		e	-	-	○	
		-		e	-	-	○	
		-		e	-	-	○	

<Spindle encoder cable and connector>

Item	Model	Length (m)	Contents	Manu- facturer	Compatible model												
					E/EH	EM/EMH	EJ/EJH										
For CN2	Motor side PLG cable Spindle side accuracy encoder TS5690 cable	CNP2E-1-2M	2		d	g	○	○	○								
		CNP2E-1-3M	3														
		CNP2E-1-4M	4														
		CNP2E-1-5M	5														
		CNP2E-1-7M	7														
		CNP2E-1-10M	10														
		CNP2E-1-15M	15														
		CNP2E-1-20M	20														
		CNP2E-1-25M	25														
		CNP2E-1-30M	30														
		For CN3	Spindle side encoder OSE-1024 cable							CNP3EZ-2P-2M	2		d	f	○	○	○
										CNP3EZ-2P-3M	3						
										CNP3EZ-2P-4M	4						
										CNP3EZ-2P-5M	5						
CNP3EZ-2P-7M	7																
CNP3EZ-2P-10M	10																
CNP3EZ-2P-15M	15																
CNP3EZ-2P-20M	20																
CNP3EZ-2P-25M	25																
CNP3EZ-2P-30M	30																
CNP3EZ-3P-2M	2																
CNP3EZ-3P-3M	3																
CNP3EZ-3P-4M	4																
CNP3EZ-3P-5M	5																
CNP3EZ-3P-7M	7																
CNP3EZ-3P-10M	10																
CNP3EZ-3P-15M	15																
CNP3EZ-3P-20M	20																
CNP3EZ-3P-25M	25																
CNP3EZ-3P-30M	30																
For spindle motor	Motor side PLG connector Spindle side accuracy encoder TS5690 connector	CNEPGS	-		g	○	○	○	○								
	Spindle side encoder OSE-1024 cable	CNE20-29S(10)	-		f	○	○	○	○								
For CN2/3	Applicable cable outline ø6.8 to 10mm	CNE20-29L(10)	-		f	○	○	○	○								
	Spindle encoder drive unit side connector	CNU2S(AWG18)	-		d	○	○	○	○								

■ Cable wire

The specifications of the wire used for each cable, and the machining methods are shown in this section. Mitsubishi uses the cables shown in the tables below. When manufacturing the encoder cable and battery connection cable, use the wires shown below or equivalent products.

(1) Encoder cable

(a) Heat resistant specifications cable

Wire type (other manufacturer's product)	Finish outer diameter	Sheath material	No. of pairs	Wire characteristics					
				Configuration	Conductive resistor	Withstand voltage	Insulation resistance	Heat resistance temperature	Flexibility
BD20288 Compound 6-pair shielded cable Specification No. Bangishi-17145 (Note 1)	8.7mm	Heat resistant PVC	2 (0.5mm ²)	100 strands/ 0.08mm	40.7Ω/km or less	500VAC/ 1min	1000 MΩ/km or more	105°C	70×10 ⁴ times or more at R200
			4 (0.2mm ²)	40 strands/ 0.08mm	103Ω/km or less				

(b) General-purpose heat resistant specifications cable

Wire type (other manufacturer's product)	Finish outer diameter	Sheath material	No. of pairs	Wire characteristics					
				Configuration	Conductive resistor	Withstand voltage	Insulation resistance	Heat resistance temperature	Flexibility
BD20032 Compound 6-pair shielded cable Specification No. Bangishi-16903 Revision No. 3 (Note 1)	8.7mm	PVC	2 (0.5mm ²)	100 strands/ 0.08mm	40.7Ω/km or less	500VAC/ 1min	1000 MΩ/km or more	60°C	100×10 ⁴ times or more at R200
			4 (0.2mm ²)	40 strands/ 0.08mm	103Ω/km or less				

(Note 1) BANDO Electric Wire (<http://www.bew.co.jp/>)

(Note 2) The Mitsubishi standard cable is the (a) Heat resistant specifications cable. When the working environment temperature is low and so higher flexibility is required, use the (b) General-purpose heat resistant specifications cable.

Compound 6-pair cable structure drawing

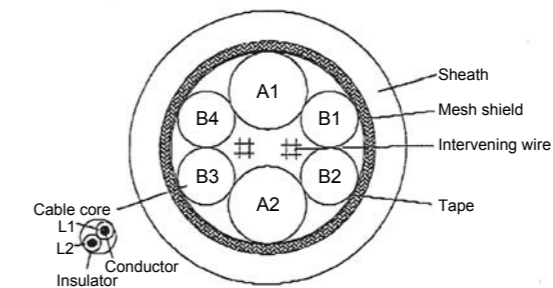

Core identification

Pair No.	Insulator color	
	L1	L2
A1 (0.5mm ²)	Red	White
A2 (0.5mm ²)	Black	White
B1 (0.2mm ²)	Brown	Orange
B2 (0.2mm ²)	Blue	Green
B3 (0.2mm ²)	Purple	White
B4 (0.2mm ²)	Yellow	White

(2) Battery connection cable

Wire type (other manufacturer's product)	Finish outer diameter	Sheath material	No. of pairs	Wire characteristics					
				Configuration	Conductive resistor	Withstand voltage	Insulation resistance	Heat resistance temperature	Flexibility
J14B101224-00 Two core shield cable (Note 1)	3.3mm	PVC	1 (0.2mm ²)	7strands / 0.2mm	91.2Ω/km or less	500VAC/ 1min	1000MΩ/km or less	80°C	R33mm

(Note 1) Junkosha Inc. <http://www.junkosha.co.jp/english/index.html>
Dealer: TOA ELECTRIC INDUSTRIAL CO.,LTD. <http://www.toadenki.co.jp/en/>

Two core shield cable structure drawing

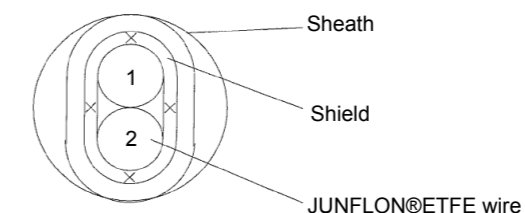

Core identification

No.	Insulator color
1	Red
2	Black

SOFTWARE TOOLS

For details on each software tool, refer to the software tools catalog (BNP-A1224).

Process flow from machine design and development to operation and maintenance



•NC-related processes

Servo selection	Custom screen creation	Parameter creation	Training
NC Servo Selection	NC Designer2	NC Configurator2	NC Trainer2
	NC Compiler2	Servo/spindle adjustment	Operation
	Debug	Machine adjustment	Maintenance
	NC Trainer2 plus	NC Analyzer2	NC Explorer
			NC Monitor2
			NC Visualizer [*]

[*] Refer to the leaflet (BNP-A1239) for details.

•Machine design

[NC Servo Selection]
Input machining parameters to determine the optimum servo motor. This function automatically calculates spindle acceleration/deceleration time and selects the optimum power supply module.

Use the following instructions to set machining parameters

Calculation results of the spindle acceleration/deceleration times

The spindle acceleration/deceleration times are shown in a graph.

Servo motor selection

•Electrical circuitry design

Combine the parts to customize the screen without programming.

Customize buttons with original pictures.

Edit PLC program with PLC development tool of NC Trainer2 plus.

Customize a screen using NC Designer2 and check its operation using NC Trainer2 plus.

[NC Designer2]
We provide a developmental environment where the MTB can customize screens easily. Two types of screen development methods are available; the interpreter method (programming without C++) for simple screen development, and the compilation method with a complex controller (programming with C++).

[NC Compiler2]
NC Compiler2 is required when the compilation method is applied.

[NC Trainer2 Plus]
NC Trainer2 plus supports customization development; it helps to program the ladder programming of the user PLC to be developed by machine tool builders and debug it and check the operations of customized screens.

•Machine assembly and adjustment

Check and setup the parameters list using a computer.

Check the contents of the parameters in the help section.

[NC Configurator2]
NC parameters required for NC control or machine operation can be edited on a computer. It is also possible to create initial parameters simply by inputting the machine configuration.

•Machine assembly and adjustment

Adjusting with simple parameter settings

Servo parameters are adjusted automatically

Results displayed in bode diagram

[NC Analyzer2]
Servo parameters can be adjusted automatically by measuring and analyzing machine characteristics. Measurement and analysis can be done by running a servo motor using the machining program for adjustment, or using the vibration signal. This function can sample various types of data.

•Operation and maintenance

[NC Trainer2]
NC Trainer2 plus supports customization development; it helps to program the ladder programming of the user PLC to be developed by machine tool builders and debug it and check the operations of customized screens.

Education

Operation check

Results

- Put skills obtained into practice
- Smooth start-up
- Quick setup/machining

Machining data file

Drag and drop to transfer machining data files

[NC Explorer]
CNC machining data can be managed using Windows® Explorer on a computer when the computer is connected to multiple CNCs via Ethernet.

NC Explorer

Ethernet

Machining data file

Monitor the status of multiple CNCs on one computer

[NC Monitor2]
Taking advantage of connection with a factory network, CNC operation status can be monitored from remote locations. Several CNCs can be connected and monitored simultaneously.

NC Monitor2

Ethernet

Application development support

[Mitsubishi CNC Communication Software (FCSB1224W000)]
This software provides a bunch of API functions. They facilitate development of an Windows application which requires connection and communication with Mitsubishi CNCTM. You can use the common interfaces for any Mitsubishi CNC model, which leads to high efficiency in development.

(*) The compatible model is Mitsubishi CNCs after M700/M70.

Development language: VC++/VB

Example of application

- Data collection/monitoring
- Operation monitoring
- Display/operation panel function
- Program creation/edit
- Production control
- CAD/CAM

Example of communication with CNC

- Start/stop the machining program
- Upload/download files
- Acquire coordinate value, alarm/diagnosis information
- Read/write NC data such as tools and variables
- Read/write device information

PC

MITSUBISHI CNC Communication Software (FCSB1224W000)

Runtime Library

API API API API

Windows OS

Ethernet

MITSUBISHI CNC

MITSUBISHI CNC

MITSUBISHI CNC

GLOBAL SALES & SERVICE NETWORK

■: Production site ●: FA Center ○: Service Center/Service Satellite

Providing reliable services in regions around the world
- our Best Partner commitment to you

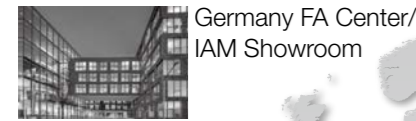

Germany FA Center/
IAM Showroom



Korea FA Center/IAM Showroom



Tokyo Head Office



Industrial Mechatronics
Systems Works/
Nagoya Works



North America FA Center

EUROPE
· MITSUBISHI ELECTRIC EUROPE B.V.
European Service Headquarters
(Dusseldorf, GERMANY)
TEL: +49-2102-486-5000
FAX: +49-2102-486-5910
· South Germany Service Center (Stuttgart)
· France Service Center (Paris)
· France Service Satellite (Lyon)
· Italy Service Center (Milan)
· Italy Service Satellite (Padova)
· U.K. Service Center
· Spain Service Center
· Poland Service Center
· Hungary Service Center
· MITSUBISHI ELECTRIC TURKEY ELEKTRİK ÜRÜNLERİ A.Ş.
Turkey Service Center
· Czech Republic Service Center (Service Partner)
· MITSUBISHI ELECTRIC RUSSIA LLC
Russia Service Center
· Sweden Service Center
· Bulgaria Service Center (Service Partner)
· Ukraine Service Center (Kiev) (Service Partner)
· Belarus Service Center (Service Partner)
· South Africa Service Center (Service Partner)

KOREA
· MITSUBISHI ELECTRIC AUTOMATION
KOREA CO., LTD. (KOREA FA CENTER)
Korea Service Center
TEL: +82-2-3660-9631
FAX: +82-2-3664-8668
· Korea Daegu Service Satellite

JAPAN
· MITSUBISHI ELECTRIC CORPORATION
(TOKYO HEAD OFFICE,
INDUSTRIAL MECHATRONICS SYSTEMS WORKS/
NAGOYA WORKS)
· MITSUBISHI ELECTRIC MECHATRONICS
ENGINEERING CORPORATION
(Headquarters)
TEL: +81-52-722-6620
FAX: +81-52-722-6662

AMERICA
· MITSUBISHI ELECTRIC AUTOMATION INC.
(AMERICA FA CENTER)
Central Region Service Center (Chicago)
TEL: +1-847-478-2500
FAX: +1-847-478-2650

- Minneapolis, MN Service Satellite
- Detroit, MI Service Satellite
- Grand Rapids, MI Service Satellite
- Milwaukee, WI Service Satellite
- Cleveland, OH Service Satellite
- Indianapolis, IN Service Satellite
- St. Louis, MO Service Satellite
- South/East Region Service Center (Georgia)
- Charleston, SC Service Satellite
- Charlotte, NC Service Satellite
- Raleigh, NC Service Satellite
- Dallas, TX Service Satellite
- Houston, TX Service Satellite
- Hartford, CT Service Satellite
- Knoxville, TN Service Satellite
- Nashville, TN Service Satellite
- Baltimore, MD Service Satellite
- Pittsburg, PA Service Satellite
- Tampa, FL Service Satellite
- Syracuse, NY Service Satellite
- Orlando, FL Service Satellite
- Lafayette, LA Service Satellite
- Philadelphia, PA Service Satellite
- Western Region Service Center (California)
- San Jose, CA Service Satellite
- Seattle, WA Service Satellite
- Denver, CO Service Satellite
- Canada Region Service Center (Tronto)
- Edmonton, AB Service Satellite
- Montreal, QC Service Satellite
- Mexico Region Service Center (Queretaro)
- Monterrey, NL Service Satellite
- Mexico City, DF Service Satellite



Thailand FA Center

THAILAND
· MITSUBISHI ELECTRIC FACTORY
AUTOMATION (THAILAND) CO.,LTD.
Thailand Service Center (Bangkok)
TEL: +66-2-092-8600
FAX: +66-2-043-1231-33



Taichung FA Center

TAIWAN
· MITSUBISHI ELECTRIC TAIWAN CO., LTD.
(TAIWAN FA CENTER)
Taiwan Taichung Service Center
TEL: +886-4-2359-0688
FAX: +886-4-2359-0689
· Taiwan Taipei Service Center
· Taiwan Tainan Service Center



Brazil Votorantim FA Center

BRAZIL
· MITSUBISHI ELECTRIC DO BRASIL COMÉRCIO
E SERVIÇOS LTDA.
Votorantim Office
TEL: +55-15-3023-9000
· Blumenau Santa Catarina office

OCEANIA
· MITSUBISHI ELECTRIC AUSTRALIA PTY. LTD.
Oceania Service Center
TEL: +61-2-9684-7269
FAX: +61-2-9684-7245



India CNC Technical Center

INDIA
· MITSUBISHI ELECTRIC INDIA PVT., LTD.
CNC Technical Center (Bangalore)
TEL : +91-80-4655-2121
FAX : +91-80-4655-2147
· Chennai Service Satellite
· Coimbatore Service Satellite
· Hyderabad Service Satellite
· North India Service Center (Gurgaon)
· Ludhiana Service Satellite
· Panthnagar Service Satellite
· Delhi Service Satellite
· Jamshedpur Service Satellite
· Manesar Service Satellite
· West India Service Center (Pune)
· Kolhapur Service Satellite
· Aurangabad Service Satellite
· Mumbai Service Satellite
· West India Service Center (Ahmedabad)
· Rajkot Service Satellite



ASEAN FA Center/
IAM Showroom



ASEAN
· MITSUBISHI ELECTRIC ASIA PTE. LTD.
(ASEAN FA CENTER)
Singapore Service Center
TEL: +65-6473-2308
FAX: +65-6476-7439

INDONESIA
· PT. MITSUBISHI ELECTRIC INDONESIA
Indonesia Service Center (Cikarang)
TEL: +62-21-2961-7797
FAX: +62-21-2961-7794

VIETNAM
· MITSUBISHI ELECTRIC VIETNAM CO.,LTD.
Vietnam Ho Chi Minh Service Center
TEL: +84-28-3910 5945
FAX: +84-28-3910 5947
· Vietnam Hanoi Service Center

MALAYSIA
· MITSUBISHI ELECTRIC SALES MALAYSIA SDN. BHD.
Malaysia Service Center (Kuala Lumpur Service Center)
TEL: +60-3-7626-5032
FAX: +60-3-7960-2629
· Johor Bahru Service Satellite
· Pulau Pinang Service Satellite

PHILIPPINES
· MELCO FACTORY AUTOMATION PHILIPPINES INC.
Head Office
TEL: +63-2-8256-8042
FAX: +632-8637-2294
· Philippines Service Center



MITSUBISHI ELECTRIC
AUTOMATION MANUFACTURING
(Changshu) Co., LTD.



Shanghai FA Center/
IAM Showroom



CHINA
· MITSUBISHI ELECTRIC
AUTOMATION (CHINA) LTD.
(CHINA FA CENTER)
Shanghai Service Center
TEL: +86-21-2322-3030
FAX: +86-21-2322-3000*8422
· Qingdao Service Center
· Suzhou Service Center
· Wuzhou Service Center
· Ningbo Service Center
· Hefei Service Center
· Beijing Service Center
· Tianjin Service Center
· Xian Service Center
· Dalian Service Center
· Chengdu Service Center
· Shenzhen Service Center
· Dongguan Service Center
· Xiamen Service Center

MEMO

YOUR SOLUTION PARTNER

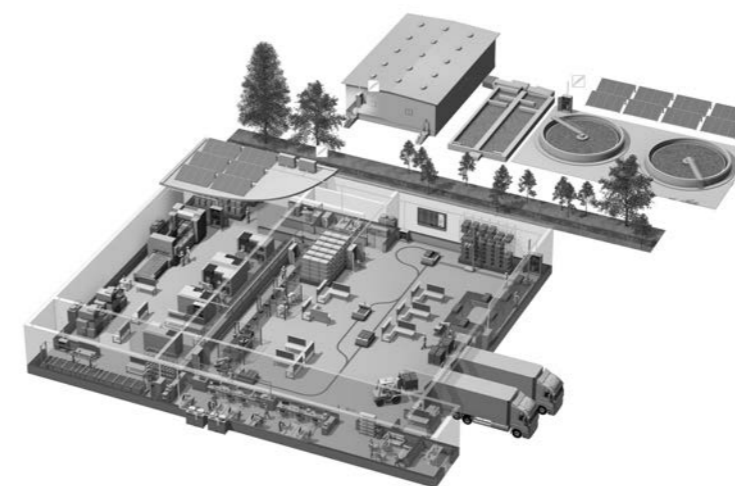

Mitsubishi Electric offers a wide range of automation equipment from PLCs and HMIs to CNC and EDM machines.

A NAME TO TRUST

Since its beginnings in 1870, some 45 companies use the Mitsubishi name, covering a spectrum of finance, commerce and industry.

The Mitsubishi brand name is recognized around the world as a symbol of premium quality.

Mitsubishi Electric Corporation, established in 1921, is active in space development, transportation, semi-conductors, energy systems, communications and information processing, audio visual equipment and home electronics, building and energy management and automation systems, and has 183 factories, laboratories and offices worldwide in over 140 countries.

This is why you can rely on Mitsubishi Electric automation solution - because we know first hand about the need for reliable, efficient, easy-to-use automation and control in our own factories.

As one of the world's leading companies with a global turnover of over 4 trillion Yen (over \$40 billion), employing over 146,000 people, Mitsubishi Electric has the resource and the commitment to deliver the ultimate in service and support as well as the best products.



Low-voltage Power Distribution Products



Transformers, Med-voltage Distribution Products



Power Monitoring and Energy Saving Products



Power (UPS) and Environmental Products



Compact and Modular Controllers



Servos, Motors and Inverters



Visualization: HMIs



Edge Computing Products



Numerical Control (NC)



Collaborative and Industrial Robots

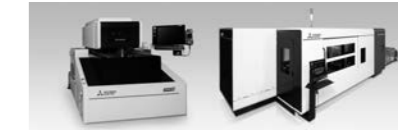

Processing machines: EDM, Lasers

*Trademarks

MELSEC, EZSocket, iQ Platform, MELSEC iQ-R, GOT, CC-Link, CC-Link/LT, CC-Link IE, CC-Link IE Field, EcoMonitorLight and SLMP are either trademarks or registered trademarks of Mitsubishi Electric Corporation in Japan and/or other countries.

Ethernet is a registered trademark of Xerox Corporation in the United States and/or other countries.

Microsoft® and Windows® are either trademarks or registered trademarks of Microsoft Corporation in the United States and/or other countries.

SD logo and SDHC logo are either registered trademarks or trademarks of LLC.

EtherNet/IP is a trademark of Open DeviceNet Vendor Association, Inc.

PROFIBUS-DP is a trademark of Profibus International.

VNC is a registered trademark of RealVNC Ltd. in the United States and other countries.

Other company and product names that appear in this manual are trademarks or registered trademarks of the respective companies.

* Not all products are available in all countries.

Global Partner. Local Friend.



[YouTube logo] is a trademark or a registered trademark of Google LLC.

Official Mitsubishi Electric Mechatronics YouTube account
 User support videos will be available, including how to backup/restore data and replace batteries as well as introduction to our products and technologies.



[Facebook logo] is a trademark or a registered trademark of Facebook, inc. [LinkedIn logo] is a trademark or a registered trademark of LinkedIn Corporation.

Official Mitsubishi Electric CNC Facebook/LinkedIn account
 Visit our page for information about exhibitions, products, technologies, and FAQ.

⚠ Safety Warning

To ensure proper use of the products listed in this catalog, please be sure to read the instruction manual prior to use.

Mitsubishi Electric Corporation Industrial Mechatronics Systems Works is a factory certified for ISO 14001 (standards for environmental management systems) and ISO 9001 (standards for quality assurance management systems)



ISO 14001
 JACO
 EC 98 J2017

UKAS
 MANAGEMENT SYSTEMS
 0051



ISO 9001
 BUREAU VERITAS
 Certification
 7828

UKAS
 MANAGEMENT SYSTEMS
 0008

CNC SELECTION(ENGLISH)
 BNP-A1233-H / ENG

MITSUBISHI ELECTRIC CORPORATION HEAD OFFICE: TOKYO BLDG., 2-7-3 MARUNOUCHI, CHIYODA-KU, TOKYO 100-8310, JAPAN