

# **MELFA Robots**

Industrial Robot

Instruction Manual  
(SD Series)

## **PROFIBUS DP-V0 Slave Interface (2D-TZ577)**





## Safety Instructions

**Before attempting to use the robot, carefully read the following safety instructions and those given in the "Safety Manual" that accompanies and take necessary actions.**

A. Safety instructions based on the requirements of the Labor Safety and Health Regulations (Articles 36, 104, 150, and 151) are listed below in abbreviated form.



### CAUTION

The robot teaching operation should be performed only by workers trained specifically in safety practices.  
(This applies to maintenance service done without shutting down the power source as well.)  
→ Implementation of safety training



### CAUTION

The robot teaching operation should be performed in accordance with established work rules which cover method or procedure used when operating the robot or actions taken to deal with all operating conditions including abnormal situations and subsequent restarting of the equipment.  
(This applies to maintenance service done without shutting down the power source as well.)  
→ Establishment of work rules



### WARNING

The robot teaching operation must be performed with a means being provided which permits an immediate shutdown of the robot.  
(This applies to maintenance service done without shutting down the power source as well.)  
→ Provision of an emergency shutdown switch



### CAUTION

During the performance of the robot teaching operation, an indication to that effect should be given in the immediate vicinity of the start switch or the like.  
(This applies to maintenance service done without shutting down the power source as well.)  
→ Indication of an ongoing robot teaching operation



### DANGER

During the operation of the robot, a fence or enclosure must be put around the robot so that workers are protected from inadvertent contact with the robot.  
→ Setting-up of a safety fence



### CAUTION

Robot operation should be started on a specific signal given to every worker concerned according to an established rule.  
→ A signal for starting an equipment operation



### CAUTION

Maintenance service should in principle be carried out with power being shut off. Ensure that an indication showing maintenance service being in progress is given in the immediate vicinity of the start switch or the like.  
→ Indication of an ongoing maintenance service

















### CAUTION

Before starting the operation of the robot, check the robot, emergency stop switch, and other associated devices for good condition.  
→ Checkup before starting robot operation

B. Safety instructions contained in the accompanying "Safety Manual" are listed below in abbreviated form.

For more details, read the main text of the "Safety Manual."

-  **CAUTION** Use the robot in an environment where operational parameters (temperature, humidity, atmosphere, noise, etc.) are kept within the specified limits. Otherwise, the robot may diminish in reliability or suffer a breakdown.
-  **CAUTION** When moving the robot, keep it in an attitude specified in the handling instructions that apply. Otherwise, the robot may turn over or drop and result in personal injury or equipment breakdown.
-  **CAUTION** Install the robot securely onto a rigid mount. Insecure installation may cause the robot to become mispositioned or develop undue vibration.
-  **CAUTION** Route cables as far away from a noise source as possible. If allowed to run too close to a noise source, the cable may be a cause for robot misposition or malfunction.
-  **CAUTION** Avoid placing excessive strain on the connector or bending the cable too abruptly. A poor connection or a break in the wiring may result.
-  **CAUTION** Ensure that the mass of work including that of the robot hand does not exceed the rated load and permissible torque. Excessive work mass may give rise to an alarm condition or mechanical failure.
-  **WARNING** The robot hand and tools must be installed securely and the work must be gripped firmly in place. Otherwise, objects may become dangerous projectiles during operation, causing personal injury or property damage.
-  **WARNING** The robot and controller must be well-grounded. Otherwise, noise may give rise to malfunction or, in some cases, an electric shock may be received.
-  **CAUTION** During the operation of the robot, an indication to that effect is put out. Without such an indication, worker may inadvertently get near the robot or make an operational mistake.
-  **WARNING** Before attempting to perform a robot teaching operation within its working radius, worker must make certain that he has acquired a precedence in the control of the robot. Otherwise, the robot may be activated by a command from any external source with a danger of personal injury or property damage.
-  **CAUTION** When applying jog control to the robot, use as low a speed as possible and keep an eye on the robot. Otherwise, interference between the robot and the peripheral equipment or structure may take place.
-  **CAUTION** Before placing the robot in auto operation following a program editing, be sure to check the robot for proper trajectories by manipulating it in stepwise fashion. Otherwise, an error in the programming or other glitch may lead to interference between the robot and the peripheral equipment or structure.
-  **CAUTION** Provision should be such that during the automatic operation of the robot, the entrance/exit door of the safety fence put around the robot is locked to forestall an attempt to open it or the robot is automatically placed in a stopped state to permit the opening of the door. Otherwise, personal injury may result.
-  **CAUTION** Do not make any modification to the product concerned on your own judgment or use maintenance/repair parts other than those that are recommended by the

manufacturer.

Otherwise, mechanical failure or malfunction may be experienced.

When moving the robot arm manually from outside, do not put your hands or fingers into any opening provided on the robot.



## WARNING

You may, depending on your posture, get your hands or fingers caught between the structural members.

Do not attempt to stop the robot, whether in normal operation or in emergency, by turning off the main power supply on the robot controller.



## CAUTION

If the main power supply on the robot controller is turned off while the robot is in automatic operation, adverse effect may be caused on the precision with which the robot operates. Also, interference with the peripheral equipment or structure may result if the robot arm should drop or as it coasts to stop.

Do not turn off the main power supply on the robot controller when internal information stored on the controller (programs or parameters) is being rewritten.



## CAUTION

If the main power supply on the robot controller is turned off during automatic operation or the loading of programs/parameters, internal information stored on the controller may be corrupted.



## WARNING

If an horizontally-articulated robot is used, take care as the robot hand possibly sinks under its own weight while the brake release switch is depressed. Sinking of the robot hand may cause the robot hand to hit the peripheral equipment or structure or get your hand or finger caught between the structural members.







■ Introduction

Thank you for purchasing Mitsubishi Electric SD Series Industrial Robot.

The PROFIBUS DP-V0 Slave Interface (2D-TZ577) is an optional device which, installed into the SD Series Robot Controller, permits you to connect the Robot Controller to a PROFIBUS DP-V0 network.

Before using the Interface, read this manual and familiarize yourself with all pages to ensure safe operation and obtain maximum satisfactory service from the PROFIBUS DP-V0 Slave Interface (2D-TZ577).

Note: All descriptions in this manual assume that the user has an adequate understanding about basic operating procedures and functions which pertain to the Mitsubishi Industrial Robot SD Series. For detailed information about the basic operating procedures, refer to the "Instruction Manual - Detailed Description of Functions and Operation" which is separately issued.

■ Safety notation used in this manual:



**DANGER**

Indicates an immediately hazardous situation which, if not properly dealt with, will result in death or serious injury.



**WARNING**

Indicates a hazardous situation which, if not properly dealt with, could result in death or serious injury.



**CAUTION**

Indicates a hazardous situation which, if not properly dealt with, could result in injury, or property damage alone.

- This manual or any part thereof may not be reproduced in any form or by any form without permission.
- All the contents of this manual are subject to change without notice.
- Specification values appearing in this manual are based on the tests conducted in accordance with Mitsubishi Electric's standard procedures.
- Mitsubishi Electric prepared this manual with close attention to every detail. However, in case that you find any point in this manual which is not quite clear or any information which is not correctly presented or missing, your local sales representative or Mitsubishi MELFA Telephone Customer Service Center should be contacted for advice.

<MELFA Telephone Customer Service Center>

Telephone: 052-721-0100 (direct-dial)

Fax: 052-722-0384

Open time: 9:00~12:00 & 13:05-16:30

Monday through Friday

(National holidays and company holidays are excluded.)

- Trade names or trademarks appearing in this manual are the property of their respective owners.
- The notations "®" and "TM" are omitted in this manual.

Copyright(C) 2009 MITSUBISHI ELECTRIC CORPORATION ALL RIGHTS RESERVED

## [Table of Contents]

1.	Before Using PROFIBUS DP-V0 Slave Interface.....	1
1.1	About Terms Used in This Manual .....	1
1.2	How to Use This Manual .....	2
2.	Workflow .....	3
2.1	Work Procedure .....	3
3.	Features and Specification of 2D-TZ577 Card.....	4
3.1	What is PROFIBUS DP .....	4
3.2	Features of 2D-TZ577 Card .....	5
3.3	Specification of 2D-TZ577 Card .....	6
3.3.1	General Specification .....	6
3.3.2	Transmission Specification.....	7
3.3.3	Network Configuration.....	7
3.3.4	Accommodated Versions .....	8
3.4	Robot Parameters .....	9
3.5	Robot Controller Input/Output Signals .....	11
3.6	About Dedicated Input/Output.....	12
3.7	Specification Relative to Robot Language .....	12
3.7.1	Robot System State Variables Relative to 2D-TZ577 Card .....	12
3.8	About Output Signal Reset Patterns .....	15
3.9	Hardware of 2D-TZ577 Card.....	16
3.9.1	Overall View .....	16
3.9.2	LED .....	16
4.	Out of the Package.....	17
4.1	Checking Component Parts .....	17
4.2	Items To Be Furnished by User.....	17
5.	Hardware Setup.....	19
5.1	Hardware Setup for 2D-TZ577 Card .....	19
6.	Connection and Wiring .....	20
6.1	Installing A 2D-TZ577 Card into Robot Controller.....	20
6.1.1	CR1D Robot Controller .....	20
6.1.2	CR2D Robot Controller .....	21
6.1.3	CR3D Robot Controller .....	22
6.2	Connector Pin Configuration (D-SUB9 Pin).....	23
6.3	Wiring .....	23
6.4	About Noise Control .....	24
6.4.1	CR1D Controller.....	24
6.4.2	CR2D Controller.....	24

6.4.3	CR3D Controller.....	25
6.5	Checking Connections .....	26
7.	Procedure before Startup .....	27
7.1	Procedure for Running Self-diagnosis .....	28
7.2	Parameter Settings on the Side of Master Station .....	28
7.2.1	Procedure for Establishing Parameters .....	28
7.2.2	Slave Parameters .....	29
7.3	Parameter Settings on the Side of Robot Controller.....	32
7.4	Have A Try For It .....	34
7.4.1	Setting Dedicated Input/Output.....	34
7.4.2	About General-purpose Input/Output.....	34
7.4.3	Examples of Robot Program (Using General-purpose I/O).....	35
7.4.4	A Sample Program for Checking Input/Output .....	36
8.	Troubleshooting.....	37
8.1	A Listing of Errors.....	37
8.2	At the Occurrence of Error 8570 (PROFIBUS Communication Timeout).....	39
9.	Appendix.....	40
9.1	Displaying Option Card Information .....	40



# 1. Before Using PROFIBUS DP-V0 Slave Interface

This chapter explains checks or precautions that you should perform or take before using the PROFIBUS DP-V0 Slave Interface (2D-TZ577).

## 1.1 About Terms Used in This Manual

Table 1-1 Terms Used in This Manual

Term	Description
PROFIBUS DP-V0	A basic version of PROFIBUS DP which permits the execution of the following functions: <ul style="list-style-type: none"> <li>· Input/output data communications</li> <li>· Others</li> </ul>
PROFIBUS DP-V1	A version of PROFIBUS DP which permits the execution of the following functions in additions to those available from PROFIBUS DP-V0: <ul style="list-style-type: none"> <li>· A cyclic communications (asynchronous data communications)</li> <li>· Alarm notification</li> <li>· Others</li> </ul>
PROFIBUS DP-V2	A version of PROFIBUS DP which permits the execution of the following functions in additions to those available from PROFIBUS DP-V1: <ul style="list-style-type: none"> <li>· Time stamping</li> <li>· Others</li> </ul>
2D-TZ577	PROFIBUS DP-V0 Slave Interface for SD Series (a complete set of products)
2D-TZ577 Card	PROFIBUS DP-V0 Slave Interface Card for SD Series (TZ577)
Master Station	A station residing in the equipment (typically, PLS or personal computer) which controls a data link system. There must be at least one Master Station in any system. As described below, Master Station comes in two varieties: Class 1 and Class 2.
Class 1 Master Station	Equipment which exchanges input/output data with Slave Stations.
Class 2 Master Station	Equipment which verifies station number settings and operating statuses through communications with Slave Stations. It serves as a network administration master station and takes care of such tasks as startup, maintenance service, and diagnosis.
Slave Station	A lower-level station which communicates with Master Station.
Repeater	A device which provides a link between the segments of a PROFIBUS DP network.
Terminator resistor	Resistor connected to the individual segments of a PROFIBUS DP network at each end. Actually, terminator resistors built in the connector used with a PROFIBUS network are enabled to fulfill intended purposes.
Slave parameter	Slave station parameter established by Master Station. Items of parameter information are stated on a GSD file.
Station number	A number assigned to Master Station or Slave Station. Numbering is in the range of 0 to 125.
I/O configuration information (data module)	Information about input/output configuration at Slave Station.
Input data	Data which is sent by 2D-TZ577 Card and received by Master Station. (Data inputted by Master Station)
Output data	Data which is sent by Master Station and received by 2D-TZ577 Card. (Data outputted by Master Station)
Global control	A function which allows Class 1 Master Station to send an input/output data synchronization command to Slave Stations.
Communication WDT	A watchdog timer established in the slave parameter at Master Station.
GSD file	An electronic file stating parameter settings at Slave Station. A data setting software compliant with Master Station, which is used to establish slave parameter settings.

## 1.2 How to Use This Manual

This manual discusses the functions of the 2D-TZ577 Card with its constituent sections organized as shown in the table below. For information about the functions available from the standard Robot Controller and the operating method thereof, refer to the "Instruction Manual" that is supplied with the Controller.

Table 1-2 Organization of This Instruction Manual

Section	Title	Contents
1	Before Using PROFIBUS DP-V0 Slave Interface	This section describes how to use this document (PROFIBUS DV-V0 Slave Interface Instruction Manual). Read and familiarize yourself with the information contained before attempting to use the 2D-TZ577 Card.
2	Workflow	This section describes the work necessary to build a PROFIBUS DP system. Carry out each work step exactly as indicated.
3	Features and Specification of 2D-TZ577 Card	This chapter describes the features and specification of the 2D-TZ577 Card.
4	Out of the Package	Upon receipt of the 2D-TZ577 Card, check to see that all items are in the package and that the version of the Robot Controller is as specified.
5	Hardware Setup	Hardware setup need not be done in regard to the product in question.
6	Connection and Wiring	This section describes the method used to connect the 2D-TZ577 Card to the Master Station via cables.
7	Procedure before Startup	This section describes steps you have to take before placing PROFIBUS DP system into operation.
8	Troubleshooting	This section presents information that helps find solutions when operational anomalies or errors are encountered during the use of the 2D-TZ577 Card. Make reference to this section as occasion arises.
9	Appendix	The appendix explains the method for displaying information about the 2D-TZ577 Card by means of RT ToolBox2.

## 2. Workflow

Workflow you should follow to construct a PROFIBUS DP network system is shown below. Carry out each work step exactly as indicated.

### 2.1 Work Procedure

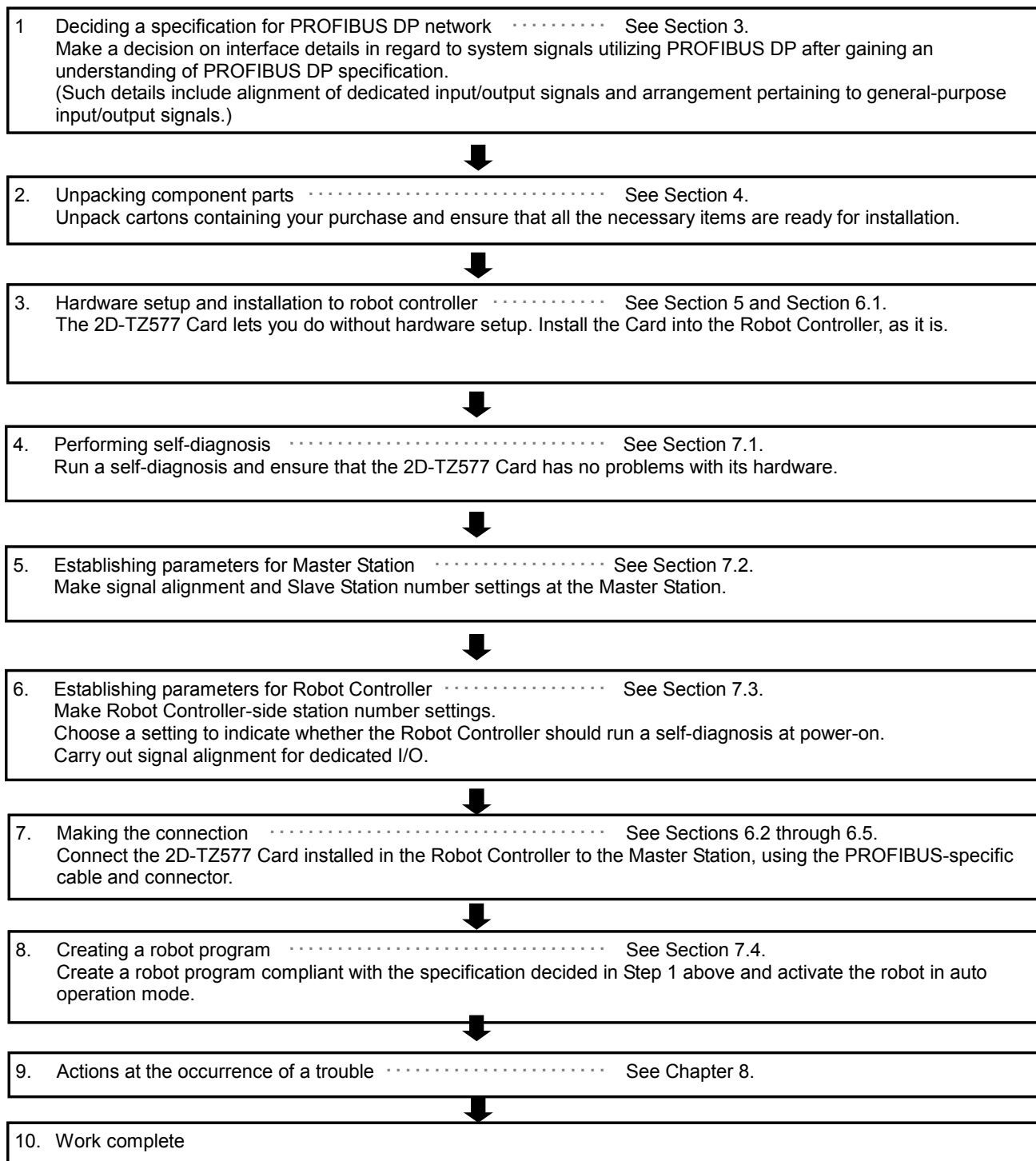

### 3. Features and Specification of 2D-TZ577 Card

#### 3.1 What is PROFIBUS DP

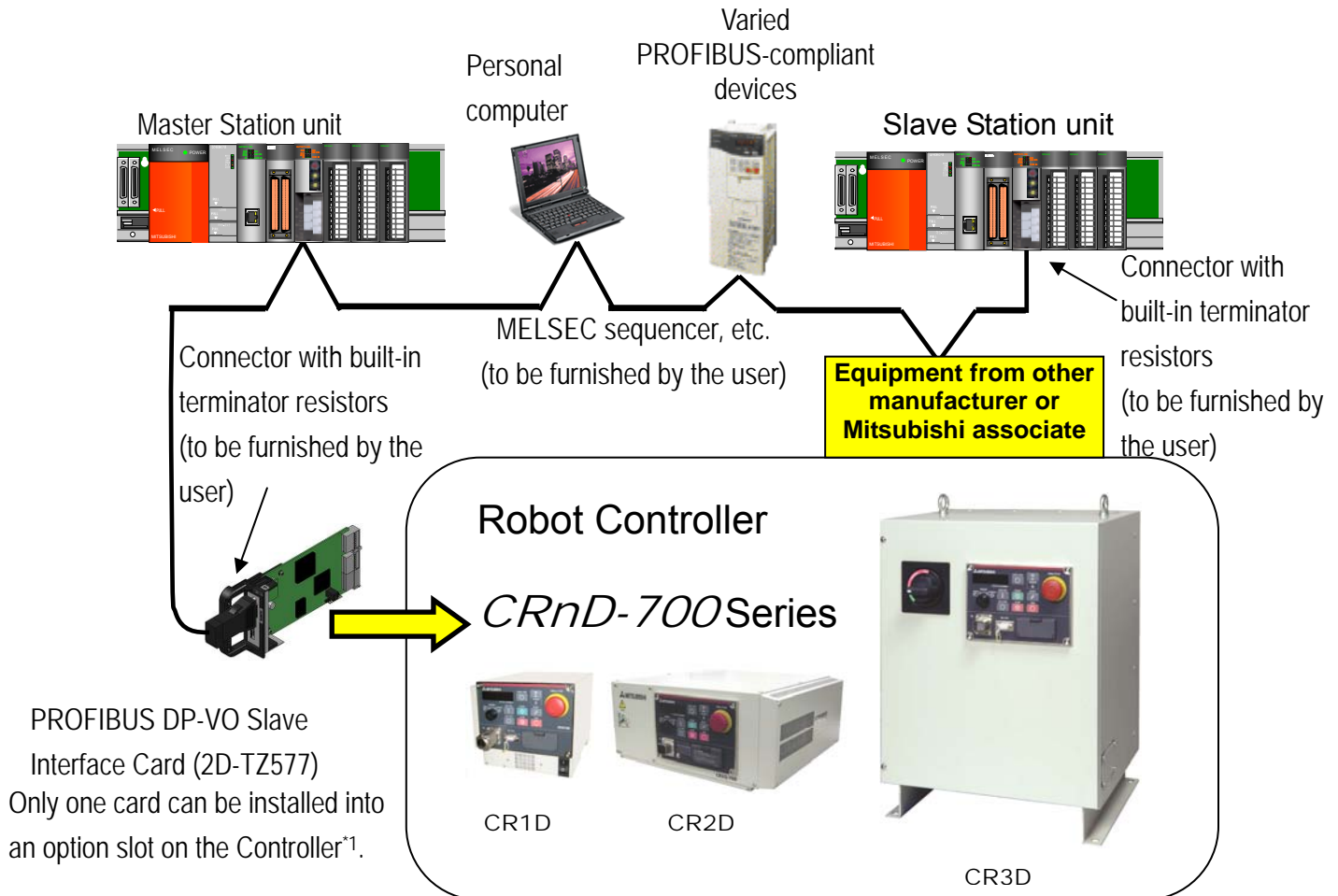

Figure 3-1 An Example of PROFIBUS Network Configuration

PROFIBUS is one of the recognized fieldbus standards. PROFIBUS comes in three variations: general-purpose PROFIBUS FMS, PROFIBUS DP for factory automation application, and PROFIBUS PA for process automation application.

The **2D-TZ577 Card** is intended to serve as a slave station which supports **PROFIBUS DP-V0** capabilities.

**It does not support PRORIBUS DP-V1 or PROFIBUS DP-V2 which is an extension of PROFIBUS DP-V0.**

(\*1) Number of the option slots varies with the Controller you use.

CR1D: Provided only with Slot 1.

CR2/3D: Provided with Slots 1 thru 3 (only one of the three slots used to install the Card at any one time)

◆◆◆ Details about PROFIBUS ◆◆◆

To learn more about PROFIBUS, visit a Japan PROFIBUS Association website at <http://www.profibus.com/>

## 3.2 Features of 2D-TZ577 Card

The 2D-TZ577 Card has the following features:

- (1) Compliance with EN 50170 Volume 2 (Part 1, 2, 3, 4, and 8)

Designed to provide compliance with EN 50170 Volume 2 (Part 1, 2, 3, 4, and 8), the 2D-TZ577 Card serves only as **a slave station in a PROFIBUS DP-V0** network.

- (2) PROFIBUS DP-V0 Slave Interface Card for SD Series

The 2D-TZ577 Card is an optional card for use with SD Series Robot Controller, not usable for SQ Series. To connect SQ Series Robot Controller to a PROFIBUS DP network, use a MELSEC-Q Series PROFIBUS DP unit.

- (3) Input/output data communications with Class 1 Master Station

The 2D-TZ577 Card is capable of conducting input/output data communications with PROFIBUS-DP Class 1 Master Station (Master Station which communicates with Slave Stations on a cyclic basis). **This card is intended to serve as a slave station which supports PROFIBUS DP-V0 capabilities. It does not support PRORIBUS DP-V1 or PROFIBUS DP-V2 which is an extension of PROFIBUS DP-V0.**

- (a) Communicatable number of pieces of data

A single 2D-TZ577 Card allows communications in the following number:

Input data - 122 words maximum	} 192 words in combined total
Output data - 122 words maximum	

- (4) Communications with Class 2 Mater Station

The 2D-TZ577 Card is capable of conducting communications, as detailed below, with Class 2 Master Station (Master Station for network administration which takes care of startup, maintenance and diagnosis services).

- Reading from input send area/output receive area
- Reading I/O configuration information
- Changing station numbers

For instructions on using the each of the listed functions, see instruction manual which is supplied with Class 2 Master Station being installed.

- (5) Input/output data swapping

The 2D-TZ577 Card permits upper/lower bytes to be swapped at the time when input/output data is sent to or received from Master Station. In a PROFIBUS DP network, the way the upper/lower bytes of input/output data is treated differs depending on the type of Master Station, but there is no need for making input/output data swapping at a program level.

- (6) Global control

The 2D-TZ577 Card supports global control capability, enabling Class 1 Master Station to control input/output data updating on the 2D-TZ577 Card by commands it transmits (SYNC, UNSYNC, FREEZE, and UNFREEZE). For instructions on using the global control capability, see instruction manual which is supplied with Class 1 Master Station being installed.

### 3.3 Specification of 2D-TZ577 Card

The following table shows the specification of the 2D-TZ577 Card.

#### 3.3.1 General Specification

Table 3-1 General Specification (2D-TZ577 Card)

Item	Specification	Remark
Type name	TZ577	
PROFIBUS specification complied with	EN50170 Volume2(Part1,2,3,4,8)	
PROFIBUS DP version supported	<b>DP-V0 only</b>	<b>DP-V1 and DP-V2 not supported</b>
Transmission rate	9.6k/19.2k/45.45k/93.75k/187.5k/500k/1.5M/3M/6M/12Mbaud	Set by parameters specified on Master Station
Station number	0 to 125	<b>Set by parameters specified on Robot</b> (default setting: 126 <sup>*1</sup> )
Maximum communicatable number of pieces of data	192 words as the combined number of pieces of input/output data (122 words as the total of pieces of input or output data)	
Option slot that accepts an interface card	Slot 1/Slop 2/Slot 3	Only one slot is used at any one time <b>(SR1D is provided with Slot 1 only.)</b>
Number of cards installed	One	Installation of more than one card is not permitted.
Concurrent use of 2D-TZ577 Card and other fieldbus option card <sup>*2</sup>	Not permitted	
Robot controller input/output number	2000 to 3951	For details about signal alignment, see " Table 3-6 A Listing of PROFIBUS Signals."
Terminator resistor	Uninstalled	If the 2D-TZ577 Card is used as a terminal station, terminator resistor on a dedicated connector should be enabled. For information about the connector, see "Table 4-2 Items To Be Furnished by User."
Input/output signal access	2D-TZ577 Card send/receive data is assigned to input/output signal No. 2000 and up. In a MELFA-BASIC V network, these signals are treated as input/output signals like parallel I/O signals are.	

(\*1) Station number 126 causes the interface to be isolated from the PROFIBUS network.

Specify station numbers in the range of 0 to 125 for the purpose of input/output date communications.

(\*2) CC-Link Interface Card and Device Net Interface Card (both under development).

### 3.3.2 Transmission Specification

Table 3-2 Transmission Specification

Item		Specification			
Transmission specification	Electrical standard and characteristic	Compliant with EIA-RS485			
	Medium	Shielded twisted-pair cable (Type A) <sup>*1</sup>			
	Network configuration	Bus type (tree type when repeater(s) is (are) used)			
	Communication method	Polling			
	Transmission encoding method	NRZ			
	Transmission rate/maximum transmission range <sup>*2</sup>	Transmission rate	Transmission range [m/segment]	Maximum transmission range with three repeaters being used [m/network]	
		9.6kbps	1200	4800	
		19.2kbps			
		45.45kbps			
		93.75kbps			
		187.5kbps	1000	4000	
		500kbps	400	1600	
		1.5Mbps	200	800	
		3Mbps	100	400	
6Mbps					
12Mbps					
Maximum number of intervening repeaters	3 <sup>*2</sup>				
Maximum number of units connected (per segment)	32 (including repeater(s))				
Number of nodes connected/segment	32				

(\*1) Specified in EN 50170 standard

(\*2) Maximum transmission distance achievable by the use of repeaters:

Maximum transmission distance [m/network] = (number of repeaters + 1) x transmission distance [m/segment]

### 3.3.3 Network Configuration

When creating a PROFIBUS DP network, note that the network comes in under the following design limits:

- (1) Number of units that can be connected to the entire network (when repeaters are used)  
Master + Slave ≤ 126
- (2) Number of units which can be connected to a segment  
Master + Slave + repeater<sup>\*1</sup> ≤ 32
- (3) Maximum number of intervening repeaters  
Up to 3 repeaters are allowed to intervene in the communication path between Master Station and 2D-TZ577 Card
- (4) It is necessary to enable terminator resistors on a dedicated connector installed at the terminal station of each segment.
- (5) Maximum number of Slave Stations which can be connected to a Master Station depends on the specification of the Master Station.

(\*1) Repeater is counted in the number of units at each of the segments.

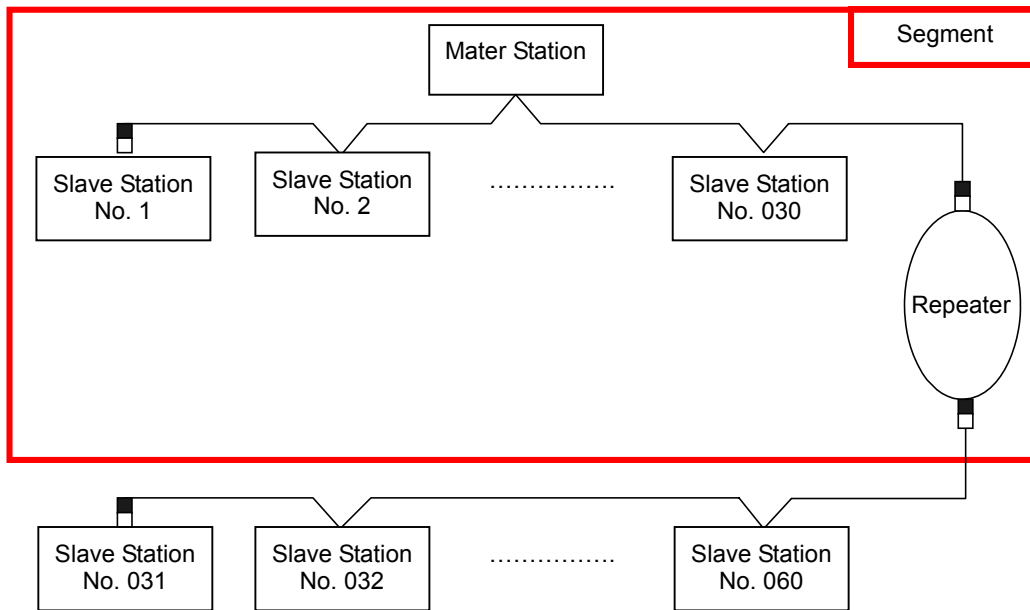

Figure 3-2 An Example of Basic PROFIBUS DP Network Configuration

### 3.3.4 Accommodated Versions

Table 3-3 Accommodated Versions

Name	Version
Robot Controller	P6k or later
Personal computer support software	RT Tool Box 2: Ver.1.0.1 or later * Ver. 1.3 or later is provided with a dialog box which can be used for making PROFIBUS-related settings. Even versions preceding 1.3 offer parameter a parameter setting screen that permits you to make PROFIBUS-related settings. For more information, see Section7.3 Parameter Settings on the Side of Robot Controller.

## 3.4 Robot Parameters

Table 3-4 A Listing of Robot Parameters Used with PROFIBUS

Parameter name	Initial value	Setting range	Description
STOP2	-1, -1	-1 /2000 to 3951	A parameter that specifies a dedicated input signal number to stop robot programs. (Because the parameter "STOP" is fixed at "0", 2D-TZ577 Card uses "STOP2" to define an external stop signal.)
ORST2000 ORST2032 : ORST3920	00000000, 00000000, 00000000, 00000000	0/1/*	A parameter that specifies value of output send data on the 2D-TZ577 Card at the time of signal output reset. (For details about related settings, see Section 3.8 Before Using PROFIBUS DP-V0 Slave Interface.)
PBMODE	0	0/2	A parameter that switches the operating mode of the 2D-TZ577 Card between "normal" and "self-diagnosis." Normal mode = 0, self-diagnosis mode = 2 <ul style="list-style-type: none"> <li>· When the self-diagnosis identifies an anomaly, an error message is displayed. ("H.8504: PROFIBUS self-diagnosis shows occurrence of an error.")</li> <li>· Return the operating mode to normal to continue with normal operation.</li> </ul>
PBMC	1	1/2	A parameter that designates Master Station as Class 1 or Class 2. Class 1 Master Station is designated at factory default. To use "Class 2," choose another parameter setting. <ol style="list-style-type: none"> <li>1: Class 1 Master (effected when the station number setting parameter PBNUM shown below is used)</li> <li>2: Class 2 Master (effected when changes of station numbers are made from Class 2 Master Station - with PBNUM not being used)</li> </ol>
PBNUM	126	-1 to 125	A parameter that specifies station number for the 2D-TZ577 Card. 0 to 125: Station number setting value (Rewriting of station number settings takes place within the flash ROM as well.) -1: Station number clear (Station number settings within the flash ROM are cleared.) * After the station numbers are cleared, the value 126 is taken on. <b>* If "No_Add_Chg" is specified with "true" when making station number settings from Class 2 Master Station, 2D-TZ577 Card is disabled for change of station numbers. To cancel this setting, clear station numbers with "PBNUM = -1."</b>
E8500	0	0/1	A parameter that is used to temporarily reset an error state when PROFIBUS-related error (indicated by a number in the 8500s) occurred. (1: Resettable (But no communications are to be carried out.) / 0: Always error during the occurrence of an anomaly in the link) <b>* This parameter does not require power supply resetting on the Robot Controller. The initial value of 0 will return if power supply resetting is done.</b>

3 Features and Specification of 2D-TZ577 Card

Parameter name	Initial value	Setting range	Description
PBCNT	40	0 to 65535	<p>A parameter that specifies an interval at which the 2D-TZ577 Card is checked for error.            Unit interval: msec            In normal condition, use the 2D-TZ577 Card at its factory default (40).            User may change the setting only when communication errors are frequently encountered under the undue influence from noise in his installation environment. Normally, a setting in the range of 40 to 70msec will do. <b>Increase the setting with great care as this may result in the inability to generate an error indication even when one occurs in the 2D-TZ577 Card.</b>            With a value greater than "1" being specified (rounding-up checked), the Controller generates an error indication only when it has detected a 2D-TZ577 Card error continuously during a specified period of time. The Controller does not generate an error indication unless it has had continuous error detection.            With "0" being specified, an error indication is generated immediately upon a 2D-TZ577 Card error being detected by the Controller.</p>

### 3.5 Robot Controller Input/Output Signals

Input/output signals processed in the Robot Controller are in the range of 2000 to 3951 maximum (equivalent to 192 words), respectively, irrespective of station numbers.

Table 3-5 PROFIBUS Input/Output Signal Numbers

	Input (received from Master Station)	Output (sent to Master Station)
Number	2000 to 3951	2000 to 3951

The data sizes of input/output signal are specified by parameter settings on the side of the Master Station. The combined number of pieces of input/output data is 192 words maximum while the respective number of pieces of input/output data is 122 words maximum.

Examples: (Input - 122 words) + (output - 70 words) = 192 words in total  
 (Input - 96 words) + (output - 96 words) = 192 words in total  
 (Input - 10 words) + (output - 10 words) = 20 words in total

Table 3-6 A Listing of PROFIBUS Signals

Number of words	Usable number of points	Start	End
0	0	-	-
1	16	2000to2015	
2	32	2000to2031	
3	48	2000to2047	
4	64	2000to2063	
5	80	2000to2079	
6	96	2000to2095	
7	112	2000to2111	
8	128	2000to2127	
9	144	2000to2143	
10	160	2000to2159	
11	176	2000to2175	
12	192	2000to2191	
13	208	2000to2207	
14	224	2000to2223	
15	240	2000to2239	
16	256	2000to2255	
17	272	2000to2271	
18	288	2000to2287	
19	304	2000to2303	
20	320	2000to2319	
21	336	2000to2335	
22	352	2000to2351	
23	368	2000to2367	
24	384	2000to2383	
25	400	2000to2399	
26	416	2000to2415	
27	432	2000to2431	
28	448	2000to2447	
29	464	2000to2463	
30	480	2000to2479	
31	496	2000to2495	
32	512	2000to2511	
33	528	2000to2527	
34	544	2000to2543	
35	560	2000to2559	
36	576	2000to2575	
37	592	2000to2591	
38	608	2000to2607	
39	624	2000to2623	
40	640	2000to2639	
41	656	2000to2655	
42	672	2000to2671	
43	688	2000to2687	
44	704	2000to2703	
45	720	2000to2719	
46	736	2000to2735	
47	752	2000to2751	
48	768	2000to2767	
49	784	2000to2783	
50	800	2000to2799	
51	816	2000to2815	
52	832	2000to2831	
53	848	2000to2847	
54	864	2000to2863	
55	880	2000to2879	
56	896	2000to2895	
57	912	2000to2911	
58	928	2000to2927	
59	944	2000to2943	
60	960	2000to2959	
61	976	2000to2975	
62	992	2000to2991	
63	1008	2000to3007	
64	1024	2000to3023	
65	1040	2000to3039	
66	1056	2000to3055	
67	1072	2000to3071	
68	1088	2000to3087	
69	1104	2000to3103	
70	1120	2000to3119	
71	1136	2000to3135	
72	1152	2000to3151	
73	1168	2000to3167	
74	1184	2000to3183	
75	1200	2000to3199	
76	1216	2000to3215	
77	1232	2000to3231	
78	1248	2000to3247	
79	1264	2000to3263	
80	1280	2000to3279	
81	1296	2000to3295	
82	1312	2000to3311	
83	1328	2000to3327	
84	1344	2000to3343	
85	1360	2000to3359	
86	1376	2000to3375	
87	1392	2000to3391	
88	1408	2000to3407	
89	1424	2000to3423	
90	1440	2000to3439	
91	1456	2000to3455	
92	1472	2000to3471	
93	1488	2000to3487	
94	1504	2000to3503	
95	1520	2000to3519	
96	1536	2000to3535	
97	1552	2000to3551	
98	1568	2000to3567	
99	1584	2000to3583	
100	1600	2000to3599	
101	1616	2000to3615	
102	1632	2000to3631	
103	1648	2000to3647	
104	1664	2000to3663	
105	1680	2000to3679	
106	1696	2000to3695	
107	1712	2000to3711	
108	1728	2000to3727	
109	1744	2000to3743	
110	1760	2000to3759	
111	1776	2000to3775	
112	1792	2000to3791	
113	1808	2000to3807	
114	1824	2000to3823	
115	1840	2000to3839	
116	1856	2000to3855	
117	1872	2000to3871	
118	1888	2000to3887	
119	1904	2000to3903	
120	1920	2000to3919	
121	1936	2000to3935	
122	1952	2000to3951	

### 3.6 About Dedicated Input/Output

Signal numbers are assigned to 2D—TZ577 Cards. Assignment of these numbers to dedicated input/output parameters permits them to be used as dedicated input/output. For more information about the dedicated input/output, see Section 6 "Functions of External Input/Output" of the "Instruction Manual - Detailed Description of Functions and Operation" which is separately issued.

### 3.7 Specification Relative to Robot Language

The follow subsection explains robot language (MELFA-BASIC V) which pertains to the 2D-TZ577 Card.

#### 3.7.1 Robot System State Variables Relative to 2D-TZ577 Card

Table 3-7 A Listing of System State Variables Used for Data Input/Output

Item	Type	Function	Read/write
M_In	Integer 1	Reads one bit of data from specified input signal.	Read
M_Out	Integer 1	Writes one bit of data into specified output signal.	Write
M_Inb	Integer 1	Reads 8 bits of data from specified input signal.	Read
M_Outb	Integer 1	Writes 8 bits of data into specified output signal.	Write
M_Inw	Integer 1	Read 16 bits of data from specified input signal.	Read
M_Outw	Integer 1	Write 16 bits of data into specified output signal.	Write

◆◆◆ "Data separation" ◆◆◆

If data writing takes place on any of the robot programs before data transfer is completed on the Master Station, an phenomenon called "tearful parting" (a loss of compatibility between input/output data on the Robot Controller side and that on the Master Station side) is experienced. For example, suppose an application program is introduced which involves writing data consecutively into an identical output address, what may happen is that no values but the one last written are conveyed to the receiver at the other end. The following diagram shows a typical case of "Data separation" which results if data reading from the Robot Controller is initiated during the course of data transfer from the Master Station to the buffer memory.

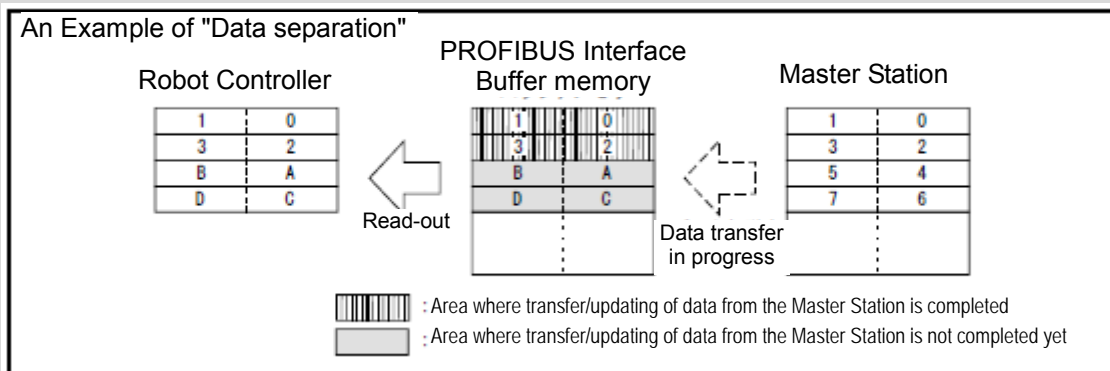

To avoid "Data separation" a read/write interlock as shown below need be provided in the application concerned (robot program or PLC ladder).

An example of interlock being used where one-word data is sent from the Master Station to the robot is illustrated in the form of a flowchart below.

Table 3-8 An Example of Input/Output Signal Alignment between Master Station and Robot

Meaning	Master Station <sup>*1</sup>	Robot
Data send/receive region	Data send region	Input: 2000 to 2015
PLC data write completed flag	WRTFLG	Input No. 2016
Robot data write completed flag	RDFLG	Output No. 2020

(\*1) For the purposes of explanation, a name is given to the Master Station input/output signal alignment. Actually, you can make any input/output signal alignment in accordance with a Master Station instruction manual that governs.

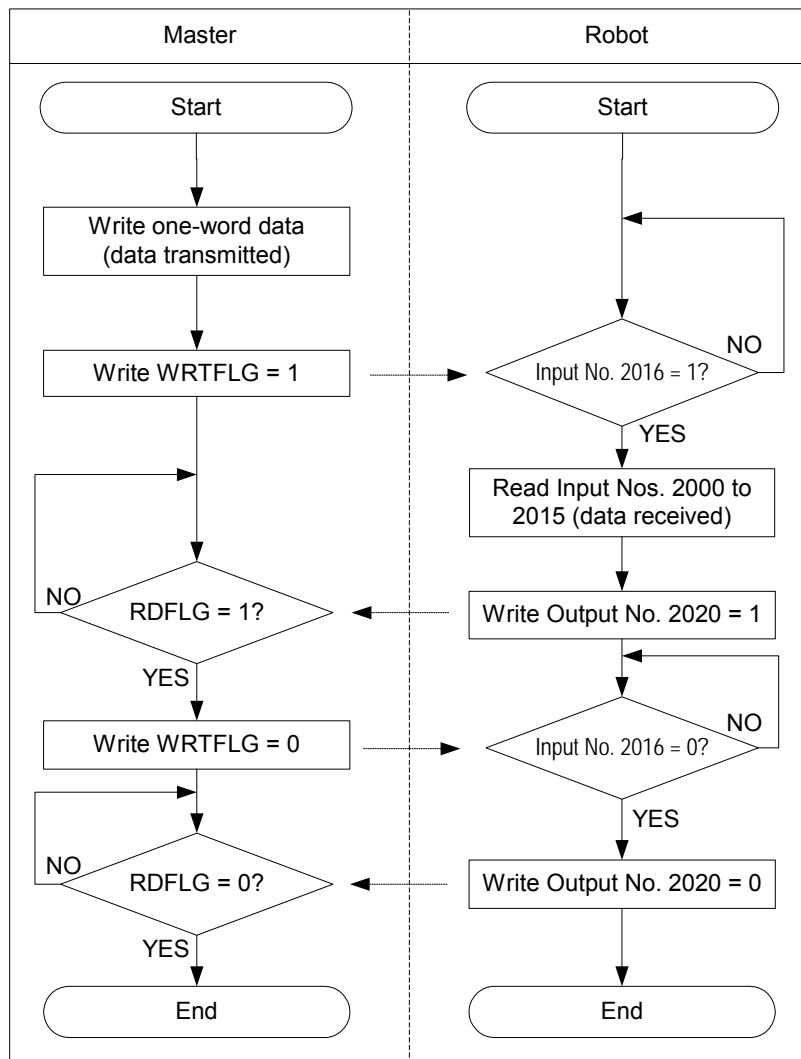

Figure 3-3 An Example of Use of Interlock

Below is an example of robot program which corresponds to the flowchart shown in Fig. 3-3. For information about the Master Station-side program (ladder, etc.), refer to the instruction manual for the equipment being used.

```

*Loop1: If M_In(2016) = 0 Then *Loop1
Mdata = M_InW(2000)
M_Out(2020) = 1
*Loop2: If M_In(2016) = 1 Then *Loop2
M_Out(2016) = 0
    
```

Table 3-9 A Listing of System State Variables Used to Verify Configuration

Variable name	Type	Designation	Function	Read/write
M_PBNUM	Integer 1	Number of station in action	Number of station which is currently in action	Read
M_PBFNUM	Integer 1	Station number settings in flash ROM	Number of station which is stored in flash ROM	Read
M_PBSYNM	Integer 1	SYNC mode signal	(a) Takes on the value "1" when 2D-TZ577 Card goes into SYNC mode in response to SYNC request from Master Station. (b) Takes on the value "0" when SYNC mode terminates due to UNSYNC request from Master Station/stopping of communications/reset. (c) Takes on the value "0" when communications with Master Station are stopped with "1" being an existing value and communication timeout error occurs. However, if communication WDT setting in Master Station-side parameter is disabled, the value "0" is not taken on because communication timeout error does not occur (output data is retained).	Read
M_PBFNZM	Integer 1	FREEZE mode signal	(a) Takes on the value "1" when 2D-TZ577 Card goes into FREEZE mode in response to FREEZE request from Master Station. (b) Takes on the value "0" when FREEZE mode terminates due to UNFREEZE request from Master Station/stopping of communications/reset. (d) Takes on the value "0" when communications with Master Station are stopped with "1" being an existing value and communication timeout error occurs. However, if communication WDT setting in Master Station-side parameter is disabled, the value "0" is not taken on because communication timeout error does not occur (output data is retained).	Read

For information about MELF-BASIC V commands and state variables other than those listed above, refer to the "Instruction Manual - Detailed Description of Functions and Operation" which is separately issued.

### 3.8 About Output Signal Reset Patterns

Factory default settings are such that startup takes place with all general-purpose output signals being off (0). You can change the state of general-purpose output signals at power-on by re-specifying the parameters listed in the table below. Note that these parameters are intended to serve the following purpose as well: performing general-purpose output signal reset operation (which is carried out with dedicated input signals) and selection of reset pattern during the execution of Clr command.

Parameter setting options include "off," "on," and "hold." The following table lists parameters which are used on the 2D-TZ577 Card for general-purpose output resetting.

Table 3-10 A Listing of Output Signal Reset Pattern Parameters

Parameter name	Leading number	Last number	Parameter name	Leading number	Last number
ORST2000	2000	2031	ORST3024	3024	3055
ORST2032	2032	2063	ORST3056	3056	3087
ORST2064	2064	2095	ORST3088	3088	3119
ORST2096	2096	2127	ORST3120	3120	3151
ORST2128	2128	2159	ORST3152	3152	3183
ORST2160	2160	2191	ORST3184	3184	3215
ORST2192	2192	2223	ORST3216	3216	3247
ORST2224	2224	2255	ORST3248	3248	3279
ORST2256	2256	2287	ORST3280	3280	3311
ORST2288	2288	2319	ORST3312	3312	3343
ORST2320	2320	2351	ORST3344	3344	3375
ORST2352	2352	2383	ORST3376	3376	3407
ORST2384	2384	2415	ORST3408	3408	3439
ORST2416	2416	2447	ORST3440	3440	3471
ORST2448	2448	2479	ORST3472	3472	3503
ORST2480	2480	2511	ORST3504	3504	3535
ORST2512	2512	2543	ORST3536	3536	3567
ORST2544	2544	2575	ORST3568	3568	3599
ORST2576	2576	2607	ORST3600	3600	3631
ORST2608	2608	2639	ORST3632	3632	3663
ORST2640	2640	2671	ORST3664	3664	3695
ORST2672	2672	2703	ORST3696	3696	3727
ORST2704	2704	2735	ORST3728	3728	3759
ORST2736	2736	2767	ORST3760	3760	3791
ORST2768	2768	2799	ORST3792	3792	3823
ORST2800	2800	2831	ORST3824	3824	3855
ORST2832	2832	2863	ORST3856	3856	3887
ORST2864	2864	2895	ORST3888	3888	3919
ORST2896	2896	2927	ORST3920	3920	3951
ORST2928	2928	2959	ORST3024	3024	3055
ORST2960	2960	2991	ORST3056	3056	3087
ORST2992	2992	3023	ORST3088	3088	3119

Parameter ORST $\circ\circ\circ\circ$  has the default values of "0000000, 00000000, 00000000, and 00000000", and can be set to specify "off," "on," and "hold" (= "0," "off," and "1") for 32 points. Leading number is assigned **from the left side**.

For example, if ORST2000 is set to "\*0000001, 00000000, 11110000, and 00000000," the following will result when power to the Robot Controller is turned back on:

Output No. 2000: Holds a state in which it was before power to the robot controller has been turned on

Output No. 2007: On

Output Nos. 2016 to 2019: On

### 3.9 Hardware of 2D-TZ577 Card

The following subsections explain the hardware of the 2D-TZ577 Card.

#### 3.9.1 Overall View

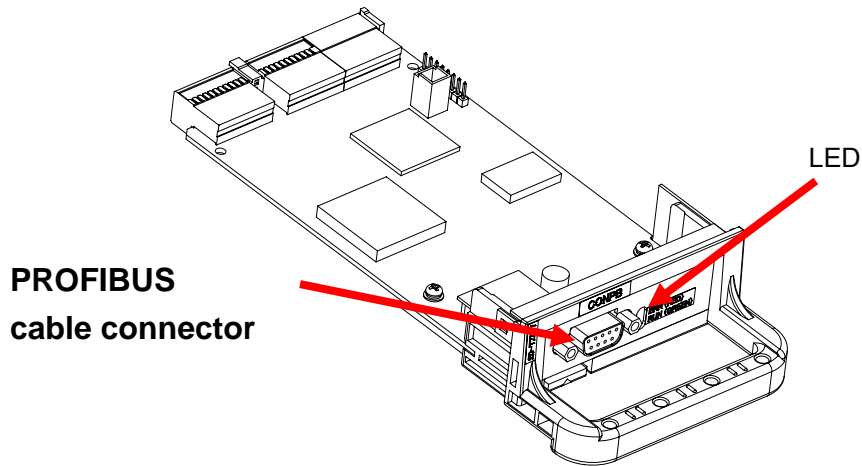

Figure 3-4 Overall View of 2D-TZ577 Card

#### 3.9.2 LED

There are two LEDs provided on the 2D-TZ577 Card, each of which indicates the state of the Card by going on or off.

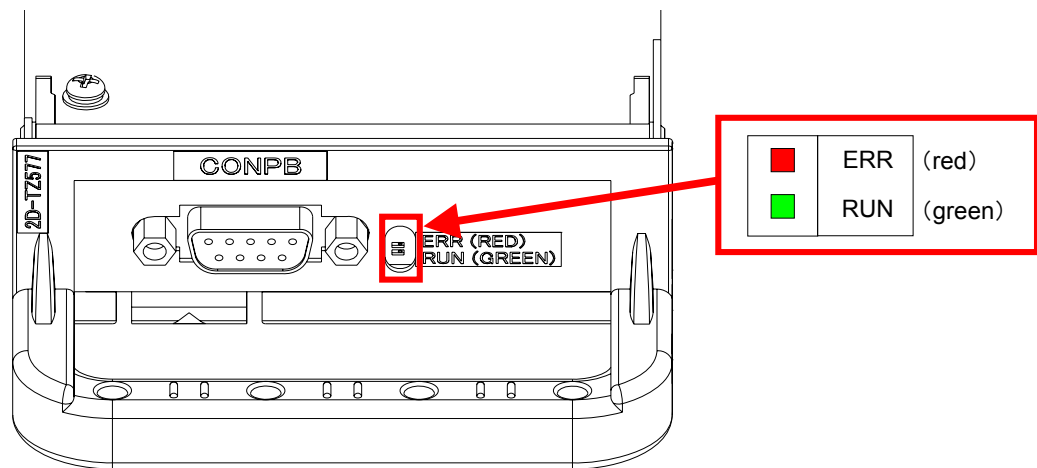

Figure 3-5 Location of LEDs

Table 3-11 A Listing of LEDs

LED name	Color	Indications
RUN	Green	On: Normal Off: Watchdog timer error occurred.
ERR	Red	On: Parameter setting error or unit error occurred. Off: Normal

## 4. Out of the Package

### 4.1 Checking Component Parts

The 2D-TZ577 Card comes standard with the component parts listed in the table below. Check your 2D-TZ577 Card to ensure that it is complete with these parts.

Table 4-1 2D-TZ577 Component Parts

No.	Item name	Type name	Quantity
[1]	Instruction manual (CD-ROM)	BFP-A8740	1
[2]	PROFIBUS DP-V0 Slave Interface Card	TZ577	1
[3]	Ferrite core	E04SR301334	2
[4]	GSD file (CD-ROM)	MLFA0BE4.gsd	1
[5]	Icon file for setting software(CD-ROM)	2DTZ577ICON.bmp	1
[6]	Cable clamp	AL4	1
[7]	Cable clamp	AL6	1

Note: Numbers in the table corresponds to those in the figure below.

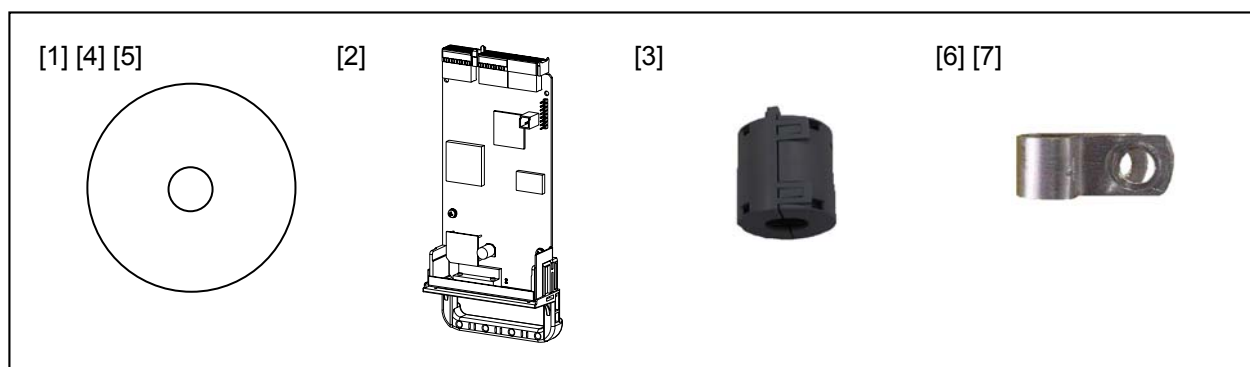

Figure 4-1 2D-TZ577 Component Parts (Illustrated)

### 4.2 Items To Be Furnished by User

The following table shows the items that the user is requested to have ready before using the 2D-TZ577 Card.

Table 4-2 Items To Be Furnished by User

Item	Requirement	Remark
Master Station <sup>*1</sup>	Master Station which is compatible with PROFIBUS DP	
Communication cable <sup>*1</sup>	Cable specifically designed for use with PROFIBUS DP * There are limits to maximum total cable length and inter-segment cable length. For details, see Figure 3-2 An Example of Basic PROFIBUS DP Network Configuration.	Mitsubishi Electric disclaims all guarantees of PROFIBUS system performance if any cable or connector other than those described here are used.

*4 Out of the Package*

Connector <sup>1</sup>	Connector specifically designed for use with PROFIBUS, having built-in terminator resistors. Recommended type name: 6GK1 500-0FC00 *Siemens. * Use a connector of straight type (180° cable outlet). When using a connector of right-angle type (90° cable outlet), note that it may give rise to problems with the cable run including interference with other cables or the rear cover (CR2D)	
------------------------	--	--

(\*1) For more details, contact the International PROFIBUS Organization.  
**Association website at <http://www.profibus.com/>**

## 5. Hardware Setup

### 5.1 Hardware Setup for 2D-TZ577 Card

Hardware setup need not be done in regard to the 2D-TZ577 Card.

Entire setup activity is performed by using parameter settings on the side of the Master Station and the Robot Controller.

For details, see Section 7.2 Parameter Settings on the Side of Master Station and Section 7.3 Parameter Settings on the Side of Robot Controller.

## 6. Connection and Wiring

### 6.1 Installing A 2D-TZ577 Card into Robot Controller

Note that only one 2D-TZ577 Card should be installed into an **option slot**<sup>\*1</sup> of the Robot Controller at any one time. If more than one card are installed into the slots, Error H.8502 "More than one PROFIBUS Card is installed" will be indicated.

(\*1) Number of the option slots varies with the Controller being used.

CR1D: Provided only with Option Slot 1

CR2/3D: Provided with Option Slots 1 thru 3

#### 6.1.1 CR1D Robot Controller

Remove the option slot interface cover on the rear of the Controller and install a 2D-TZ577 Card into the slot. During installation, use the handle fitted to the Card.

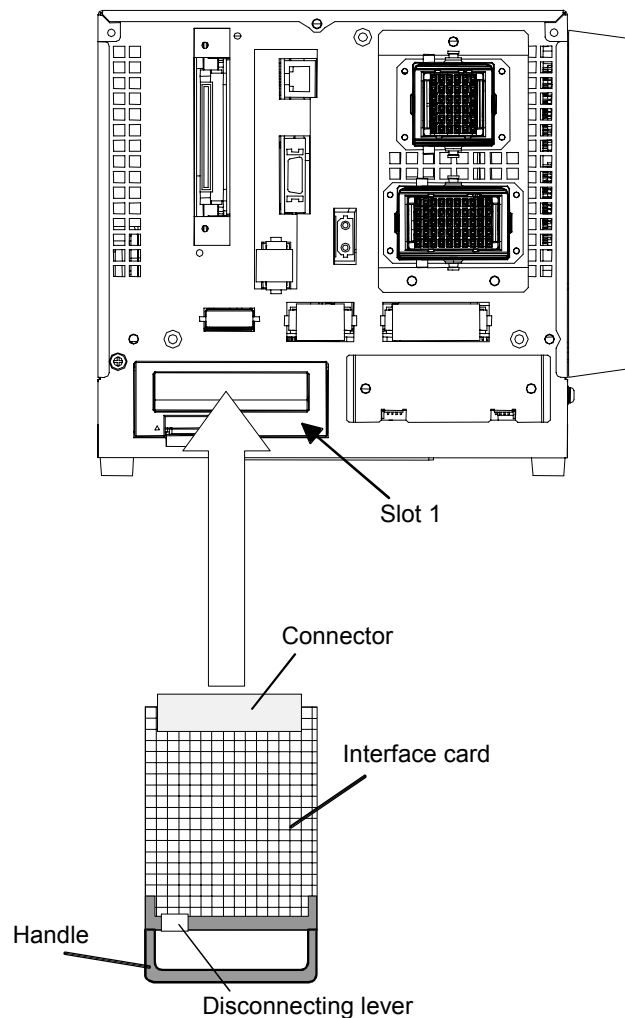

Figure 6-1 Installing A 2D-TZ577 Card (in the case of CR1D Controller)

### 6.1.2 CR2D Robot Controller

Remove any one of the interface covers provided for option slots 1 thru 3 on the rear of the Controller and install a 2D-TZ577 Card into the slot.

During installation, use the handle fitted to the Card.

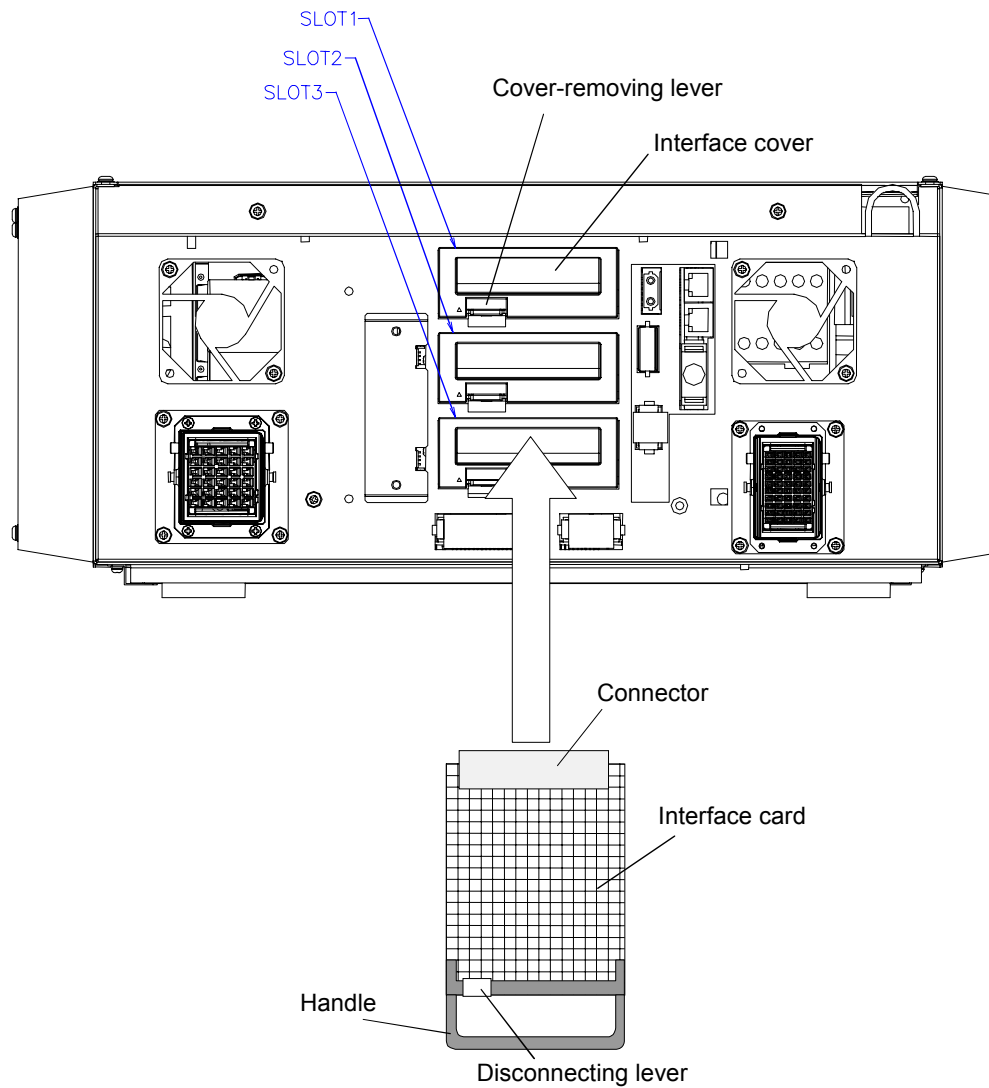

Figure 6-2 Installing A 2D-TZ577 Card (in the case of CR2D Controller)

### 6.1.3 CR3D Robot Controller

Open the door of the Robot Controller and you will see R700 CPU unit installed at the right-hand end. Remove any one of the option slot interface covers provided for option slot 1 thru 3 on the CPU unit and install a 2D-TZ577 Card into the slot.

During installation, use the handle fitted to the Card.

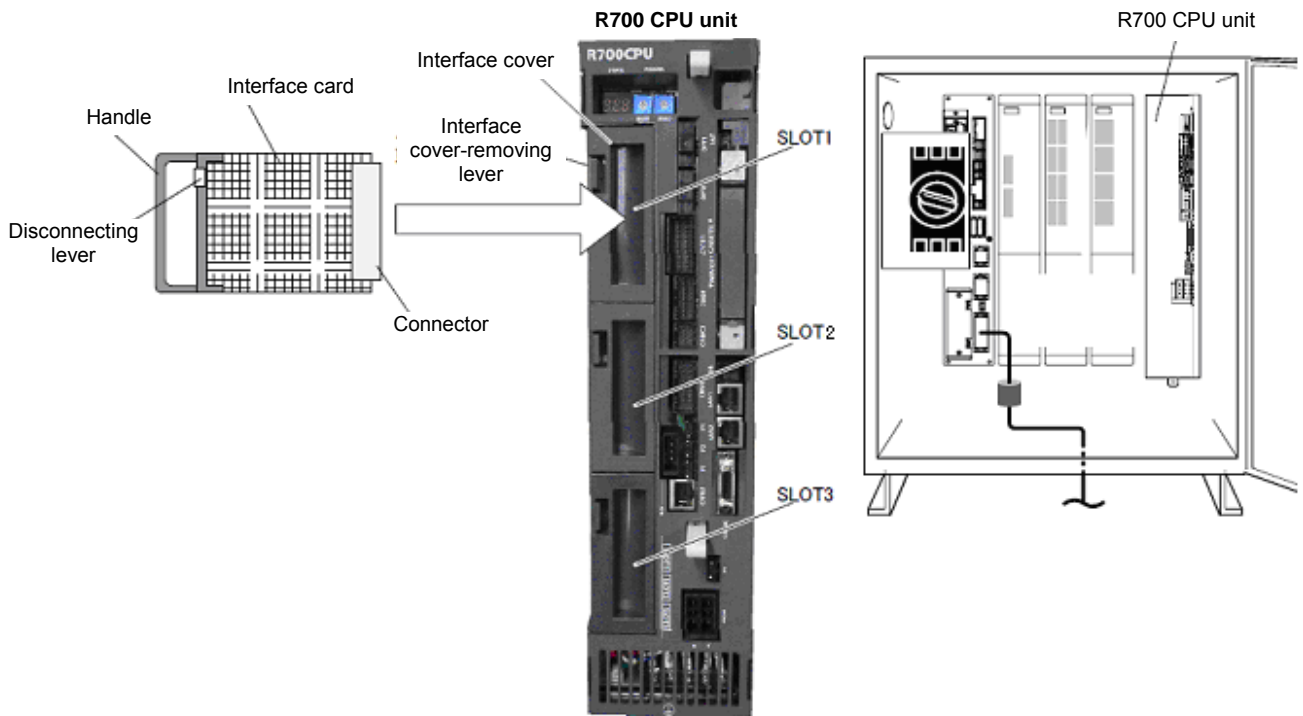

Figure 6-3 Installing A 2D-TZ577 Card (in the case of CR3D Controller)

## 6.2 Connector Pin Configuration (D-SUB9 Pin)

Table 6-1 Connector Pin Configuration

Pin No.	Name	Service
1	Not assigned	-
2	Not assigned	-
3	RxD/TxD-P	Received/transmitted data-P
4	Not assigned	-
5	DGND <sup>(*)</sup>	Data ground earth (0V)
6	VP <sup>(*)</sup>	Voltage + (+5V)
7	Not assigned	-
8	RxD/TxD-N	Received/transmitted data-N
9	Not assigned	-

(\*1) Signal used when terminator resistors are connected.

## 6.3 Wiring

The terminal station of each segment on a communication line need be provided with terminator resistors. Use a connector specifically designed for use with PROFIBUS which has built-in terminator resistors. Note: Terminator resistors are arranged so as to apply: 220Ω between (+) and (-), 390Ω between 5V and (+), and 390Ω between 0V and (-).

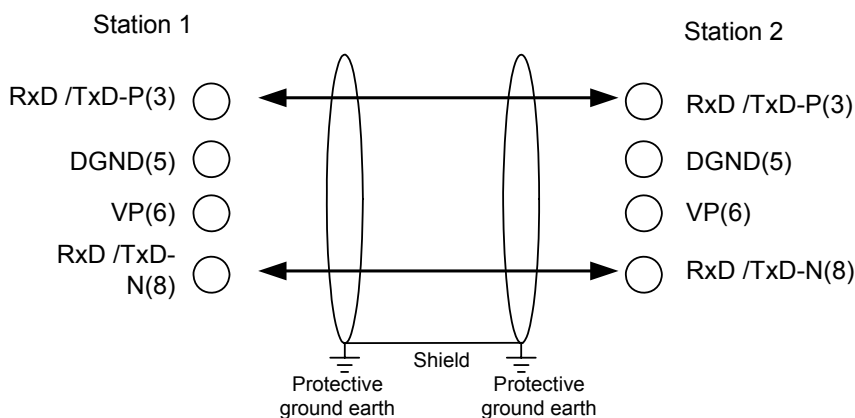

Figure 6-4 Cable Routing

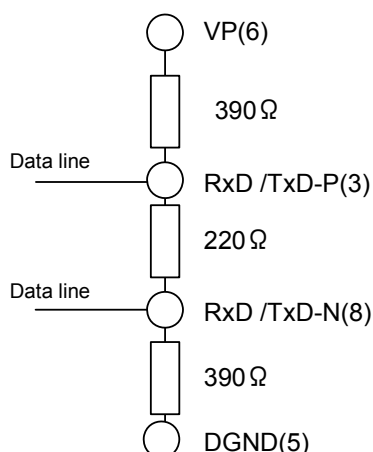

Figure 6-5 Bus Terminator Resistors

## 6.4 About Noise Control

To avoid an adverse impact from noise, strip off some sheath of the PROFIBUS cable, and attach the cable's metal blade portion to the controller casing with an earth clamp and install the accompanying ferrite core within 30cm of where the cable is clamped onto the casing.

Connection method is shown below by controller type.

### 6.4.1 CR1D Controller

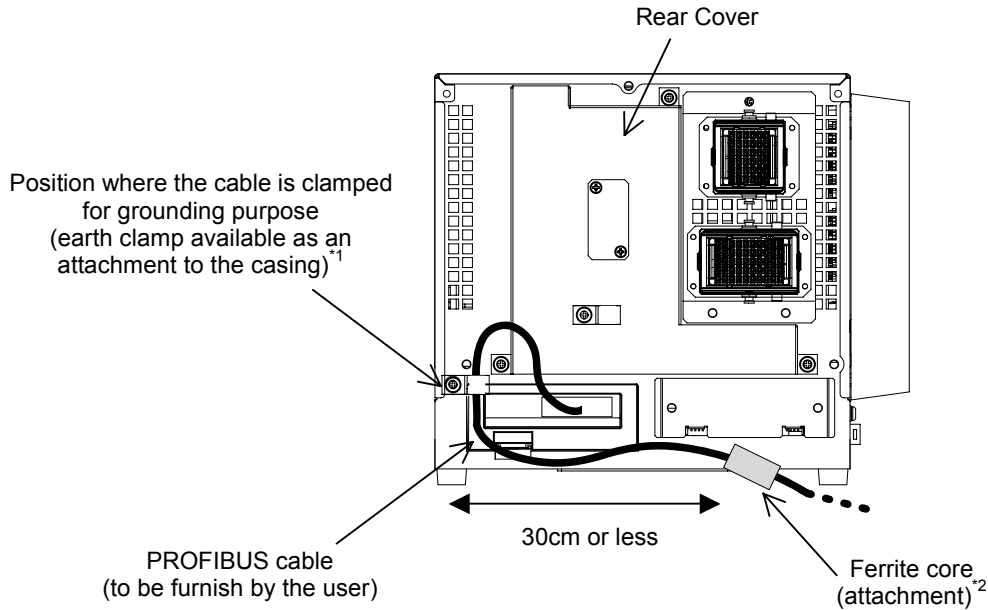

Figure 6-6 Installing PROFIBUS Cable (CR1D Controller)

### 6.4.2 CR2D Controller

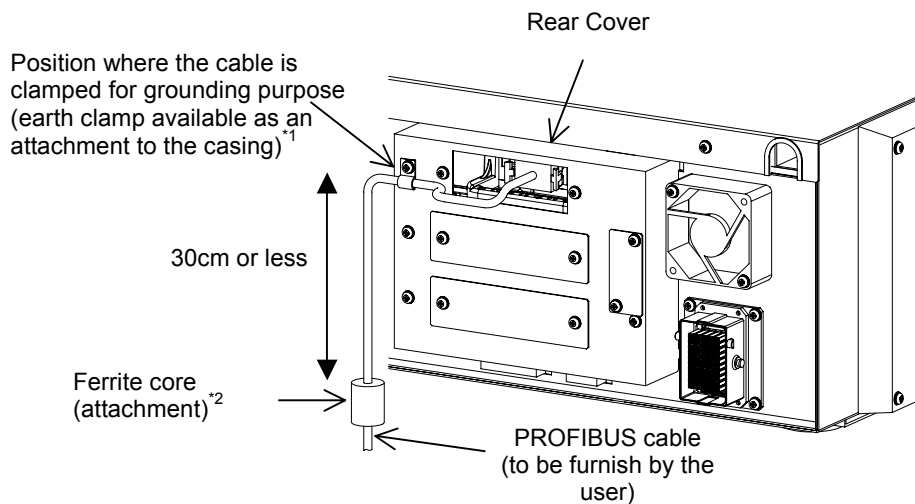

Figure 6-7 Installing PROFIBUS Cable (CR2D Controller)

## 6.4.3 CR3D Controller

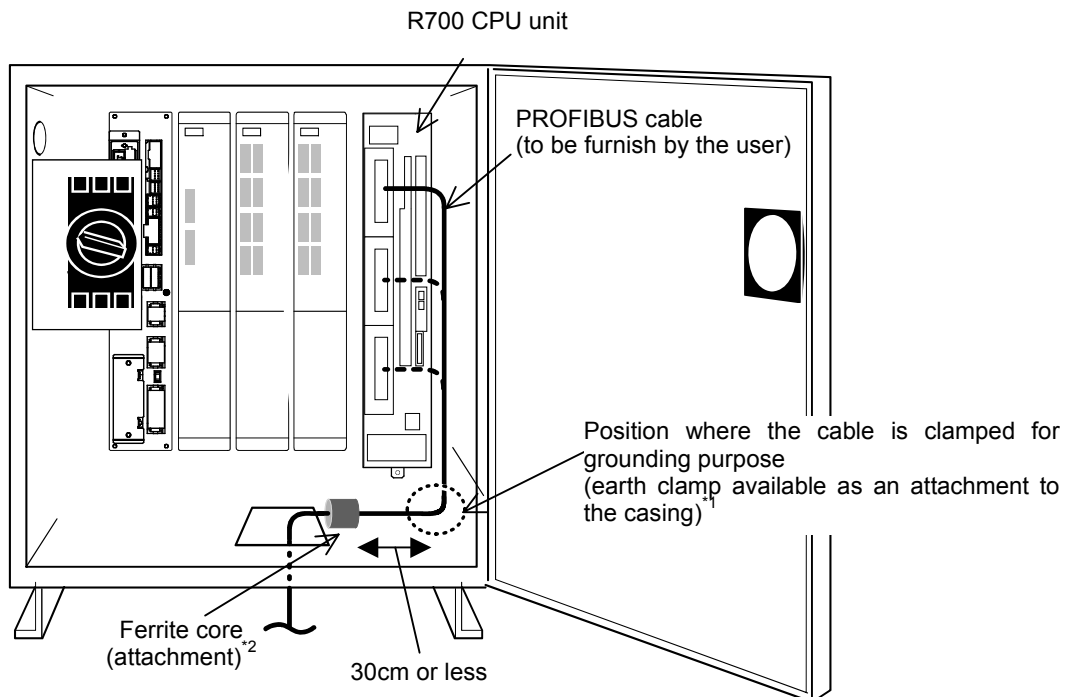
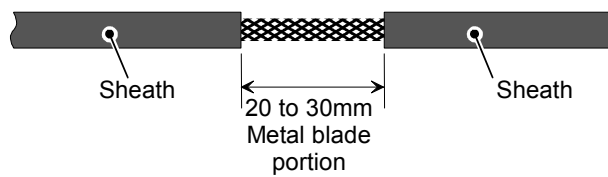
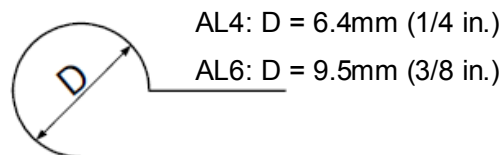

Figure 6-8 Installing PROFIBUS Cable (CR3D Controller)

- (\*1) Position where the cable is clamped for grounding purpose  
Strip off some sheath of the cable and keep metal blade portion in contact with the controller casing.



- (\*2) When Siemens PROFIBUS FC standard cable (8.0mm O.D.) is used, recommended metal clamps are:  
AL4 or AL6 \*RICHCO INC



## 6.5 Checking Connections

Before placing the 2D-TZ577 Card in service, go through the following checklist to avoid oversights.

Table 6-2 Checklist for Proper Connections

No.	Item confirmed	Check
1	Is the 2D-TZ577 Card securely installed into the Controller's slot?	
2	Is the RPOFIBUS Cable linking the 2D-TZ577 Card to the user's external equipment properly connected?	
3	Is the special-purpose connector installed at each end of the PROFIBUS network configured to apply terminal resistance as specified?	
4	Is the ferrite core is installed in place?	

## 7. Procedure before Startup

The following diagram shows the procedure performed to place the 2D-TZ477 Card in operation.

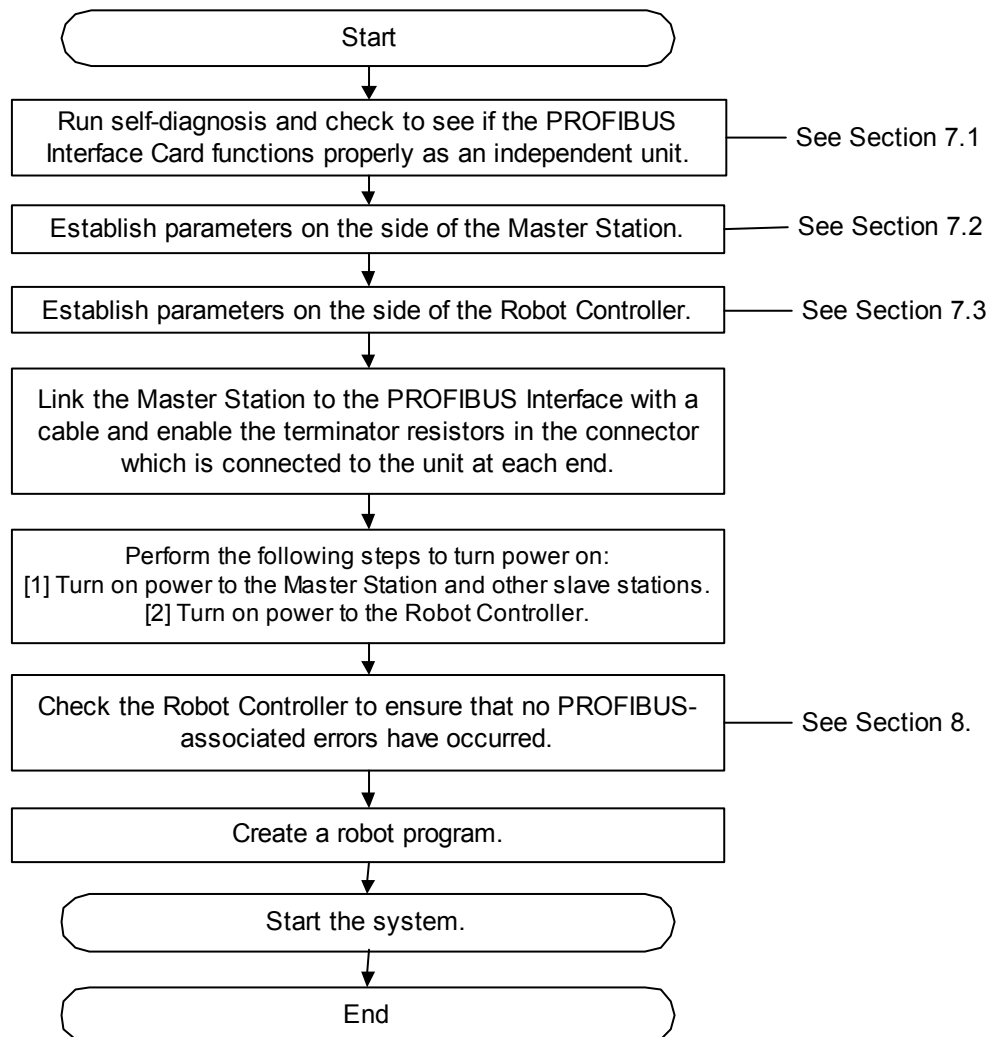

Figure 7-1 Procedure Before Startup



### CAUTION

#### **About setting station numbers from Class 2 Master Station**

When setting station numbers from Class 2 Master Station, ensure that cable link is established between the Master Station and the PROFIBUS Interface Card.

## 7.1 Procedure for Running Self-diagnosis

The following subsections explain the procedure used to run self-diagnosis and states which are observed while the self-diagnosis goes on.

(1) Procedure for running self-diagnosis

- [1] Turn on power to the Robot Controller.
- [2] Set robot parameter to self-diagnosis mode. (Set robot parameter as "PBMODE = 2." For details, see "Table 3-4 A Listing of Robot Parameters Used with PROFIBUS".)
- [3] Turn off power to the Robot Controller and turn power back on.
- [4] While self-diagnosis goes on, display on the operation panel of the Robot Controller flashes like >777< ↔ blank.
- [5] If the results of self-diagnosis are "normal" .....The Robot Controller will start normally and the 2D-TZ577 Card will stand by for parameters from the Master Station.

If the results of self-diagnosis are "abnormal" ... H.8504 Error (error identified in PROFIBUS self-diagnosis) will occur.

\* Parameter need be set as "PBMODE = 0" if it is not desired to run self-diagnosis at the subsequent startup.

(2) Corrective actions at the occurrence of error

If the results of self-diagnosis are "error," replace the 2D-TZ577 Card.

When replacing the card, contact its manufacturer for advice.

## 7.2 Parameter Settings on the Side of Master Station

### 7.2.1 Procedure for Establishing Parameters

Establish parameters listed below on the side of Master Station.

Table 7-1 Master-side Parameters

Parameters established on the side of Master Station		Reference
Master parameters (parameters for Master Station itself)		-( <sup>*</sup> 1)
Bus parameters (communication parameters for PROFIBUS-DP network)		-( <sup>*</sup> 1)
Slave parameters (for 2D-TZ577 Card)	Station number (FDL Address)	For details, see "Table 7-2 A Listing of Slave Parameters."
	Communication WDT (Watchdog)	
	Minimum response time (Min T_sdr)	
	Group number (group identification number)	
	Data module setting	
	Data alignment setting	
	Swap setting	

(<sup>\*</sup>1) For information about items of setting, see the instruction manual for the Master Station.

For method to specify parameter settings, refer to the instruction manual for the software that is used.

<Procedure for establishing 2D-TZ577 Card slave parameters to Master Station>

- [1] Read GSD file stored in the CD-ROM supplied with the 2D-TZ577 Card into a setting software which is compatible with the Master Station.
- [2] Establish 2D-TZ577 Card slave parameters, using the setting software.
- [3] Write the parameters into the Master Station.

For information about operating the setting software, refer to the instruction manual for the software that is used.

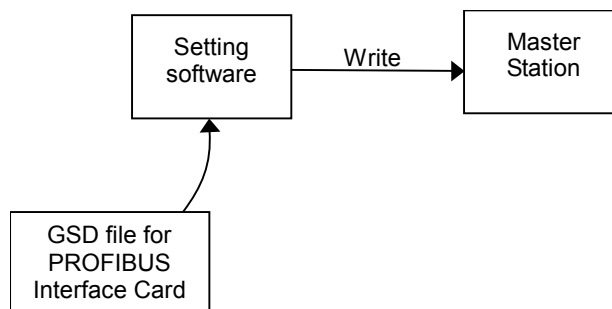

Figure 7-2 Conceptual illustration of GSD file being loaded

## 7.2.2 Slave Parameters

Parameters other than slave station numbers need be established as slave parameters for use in the Master Station. The following table shows slave parameters for use in the 2D-TZ577 Card.

Table 7-2 A Listing of Slave Parameters

Item	Setting range	Description	Remark
Station number (FDL Address)	0 to 125	Station number of 2D-TZ577 Card is defined.	If connection is made to Class 1 Master, station number need be set in the robot parameter "PBNUM" as well.
Communication WDT (Watchdog)	0/2 to 65000	Watchdog timer is defined. 0: Communication WDT setting is disabled. 2-65000: Communication WDT setting is enabled (set value x 10msec).	-
Minimum response time (Min T_sdr)	1 to 255	A minimum response time lapsed until response frames are permitted to be sent to the Master Station is defined.	-
Group number (Group identification number)	Grp1 to Grp8	Group to which a station belongs is defined. Any station is allowed to belong to more than one group (Grp 1 thru 8).	-
Data module settings (Module Configuration)	-	I/O configuration information (defined in "Cfg_Data" on the Master Station) · Types of settings: 48 patterns · Number of settings: 1 - 40	-
Data alignment mode settings (Data Alignment Mode)	0	Position of data in the output receive area/input send area of buffer memory (defined in "User_Prm_Data" on the Master Station) 0: Lump alignment mode (LUMP mode) * <b>This parameter takes on "0" only. No change is permitted.</b>	-

7 Procedure before Startup

Item	Setting range	Description	Remark
Swap settings (Word Data Swap)	0 to 1	Indication as to whether there is swapping of word data sent/received at 2D-TZ577 Card (defined in "User_Prm_Data" on the Master Station) 0: No swapping takes place. 1: Swapping takes place.	-

**(1) Number of data module settings**

Make settings so that the number of data modules per 2D-TZ577 Card falls within the limits shown below:

- Number of data modules: 40 maximum
- Combined data size
 

Input data - 122 words maximum	}	192 words in combined total
Output data - 122 words maximum		

**(2) Data module setting pattern**

An appropriate pattern is selected from among 48 patterns which derive from a combination of 3 input/output options and 16 data sizes. Note that input/output notations are based on the Master Station being the origin. For more information, see Subsection (3) **Data alignment mode settings**.

Table 7-3 Data Module Settings

Item	Type
Input/output designation	Input/output/IO
Data size	1 to 16 words

**(3) Data alignment mode settings**

Method by which to align each module in the output receive area/input send area of buffer memory is specified. The 2D-TZ577 Card comes with a lump alignment mode (lump mode) alone, permitting no changes to these settings.

- (a) Lump alignment mode (lump mode)

Input data/output data is aligned on the front in the input send area/output receive area, respectively, in the order of data module. The table below shows examples of usage statuses in the output receive area/input send area which occur on the data module settings shown.

Table 7-4 Examples of Data Module Settings

Data module settings		Output data	Input data
Data module 0	One-word input (1 word In)		One-word
Data module 1	2-word output (2 word Out)	2-word	
Data module 2	One-word input/output (1 word In, 1 word Out)	One-word	One-word
Data module 3	One-word output (1 word Out)	One-word	
Data module 4	2-word input (2 word In)		2-word
Data module 5	One-word output (1 word Out)	One-word	

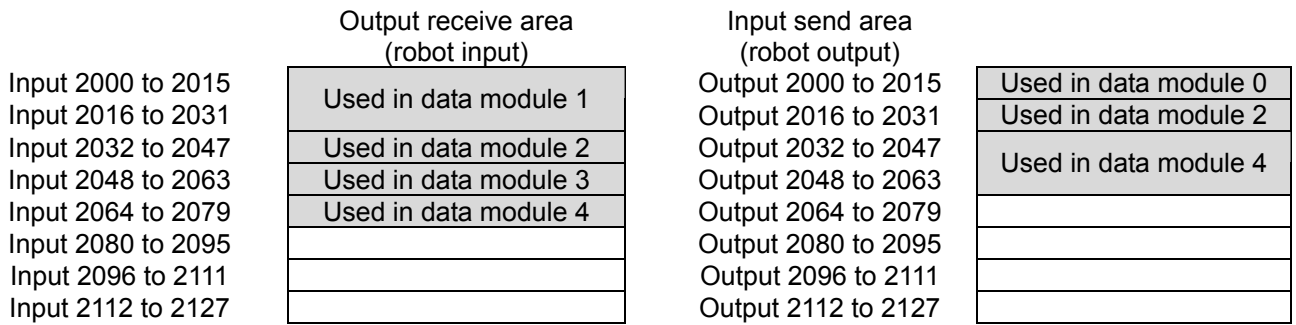

Figure 7-3 Example of Lump Alignment

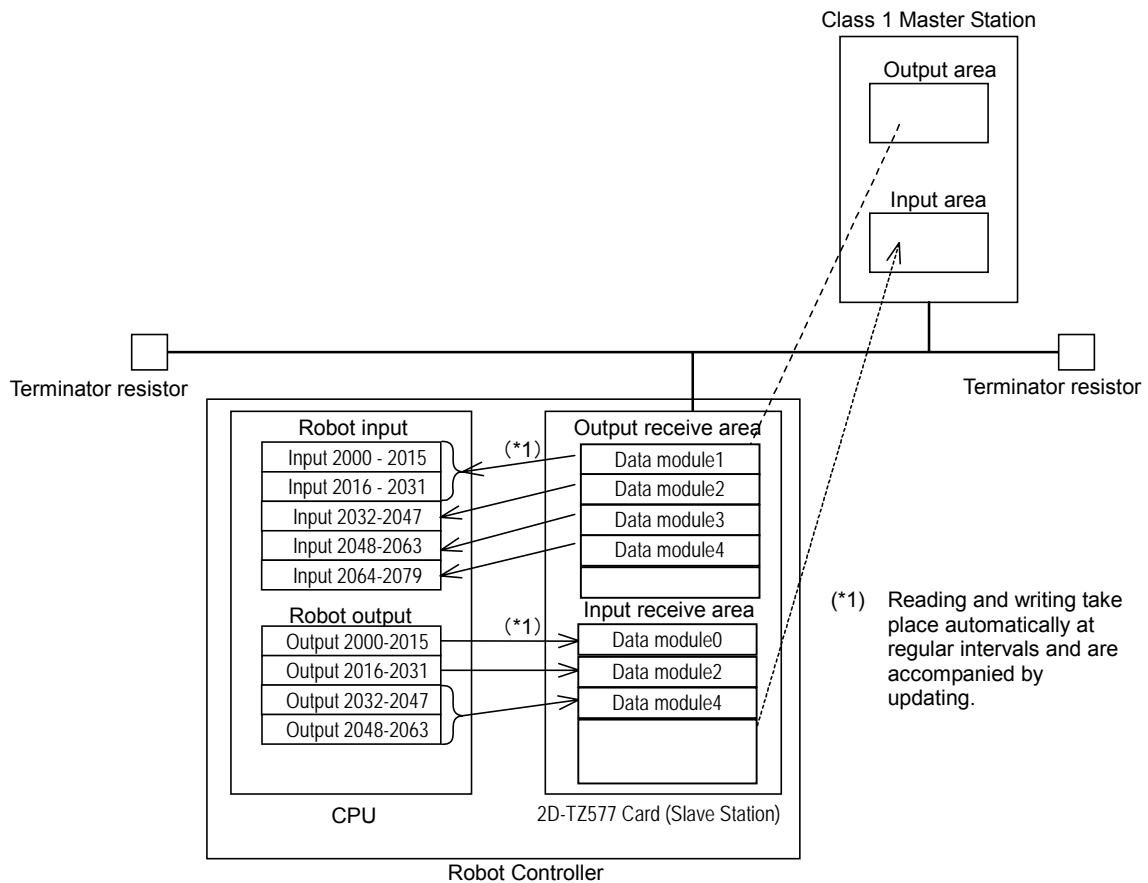

Figure 7-4 Flow of Data

## 7.3 Parameter Settings on the Side of Robot Controller

### (1) Parameter settings under R32TB, R56TB, and RT ToolBox2 (versions earlier than Ver. 1.3)

To place the 2D-TZ577 Card in operation, it is necessary to establish three typical parameters, as listed below, on the Robot Controller. For information about what to do about other parameters, see Table 3-4 A Listing of Robot Parameters Used with PROFIBUS.

For information about changing parameters, refer to the "Instruction Manual - Detailed Description of Functions and Operation" which is separately issued.

Table 7-5 Parameters on the Side of Robot Controller

Parameter name	Initial value	Setting range	Description
PBMODE	0	0/2	A parameter that switches the operating mode of the 2D-TZ577 Card between "normal" and "self-diagnosis." Normal mode = 0, self-diagnosis mode = 2 <ul style="list-style-type: none"> <li>· When the self-diagnosis identifies an anomaly, an error message is displayed. ("H.8504: PROFIBUS Self-diagnosis shows occurrence of an error.")</li> <li>· Return the operating mode to normal to continue with normal operation.</li> </ul>
PBMC	1	1/2	A parameter that designates Master Station as Class 1 or Class 2. Class 1 Master Station is designated at factory default. To use "Class 2," choose another parameter setting. <ol style="list-style-type: none"> <li>1: Class 1 Master (effected when the station number setting parameter PBNUM shown below is used)</li> <li>2: Class 2 Master (effected when changes of station numbers are made from Class 2 Master Station - with PBNUM not being used)</li> </ol>
PBNUM	126	-1 to 125	A parameter that specifies station number for the 2D-TZ577 Card. 0~125: Station number setting values (Rewriting of station number settings takes place within the flash ROM as well.) <ul style="list-style-type: none"> <li>-1: Station number clear (Station number settings within the flash ROM are cleared.)</li> </ul> <p>* After the station numbers are cleared, the value 126 is taken on.</p> <p>* <b>If "No_Add_Chg" is specified with "true" when making station number settings from Class 2 Master Station, 2D-TZ577 Card is disabled for change of station numbers. To cancel this setting, clear station numbers with "PBNUM = -1."</b></p>

### (2) Parameter settings under RT ToolBox2 (versions later than Ver. 1.3)

Under RT ToolBox2 versions later than 1.3, a PROFIBUS-specific setting window shown in Figure 7-5 is offered. You can establish three parameters shown in Table 7-5 on this screen.

In regard to the PROFIBUS Error Detection Filter (PBCNT), you may change its set values only when communication errors are frequently encountered under the undue influence from noise in your installation environment. (For more information, see Table 3-4 A Listing of Robot Parameters Used with PROFIBUS.)

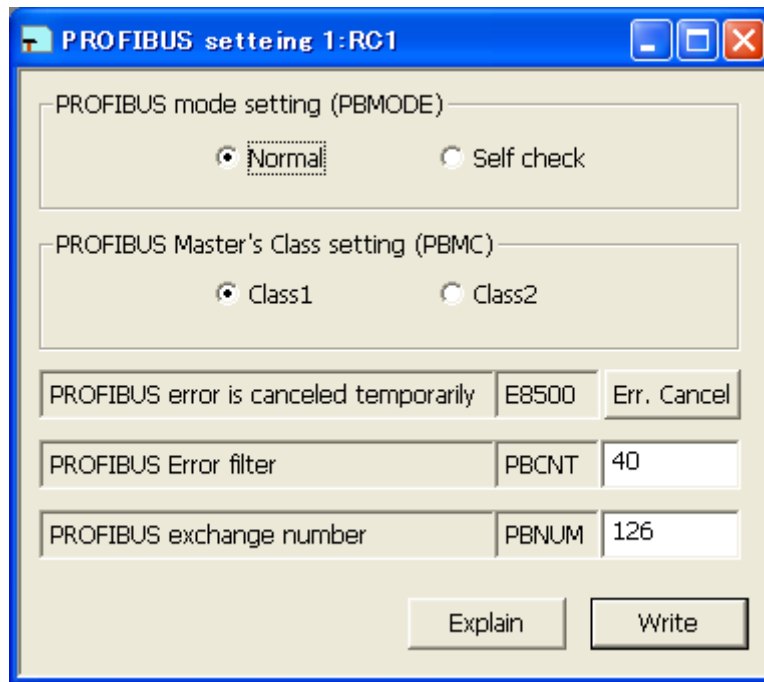

Figure 7-5 PROFIBUS Setting Screen

You can call up the PROFIBUS setting screen by expanding the Test tree under the Work Space and going through "Online" and "Parameter" and double-clicking the "PROFIBUS setting" entry or alternatively right-clicking this entry and clicking Open on the pull-down menu that appears.

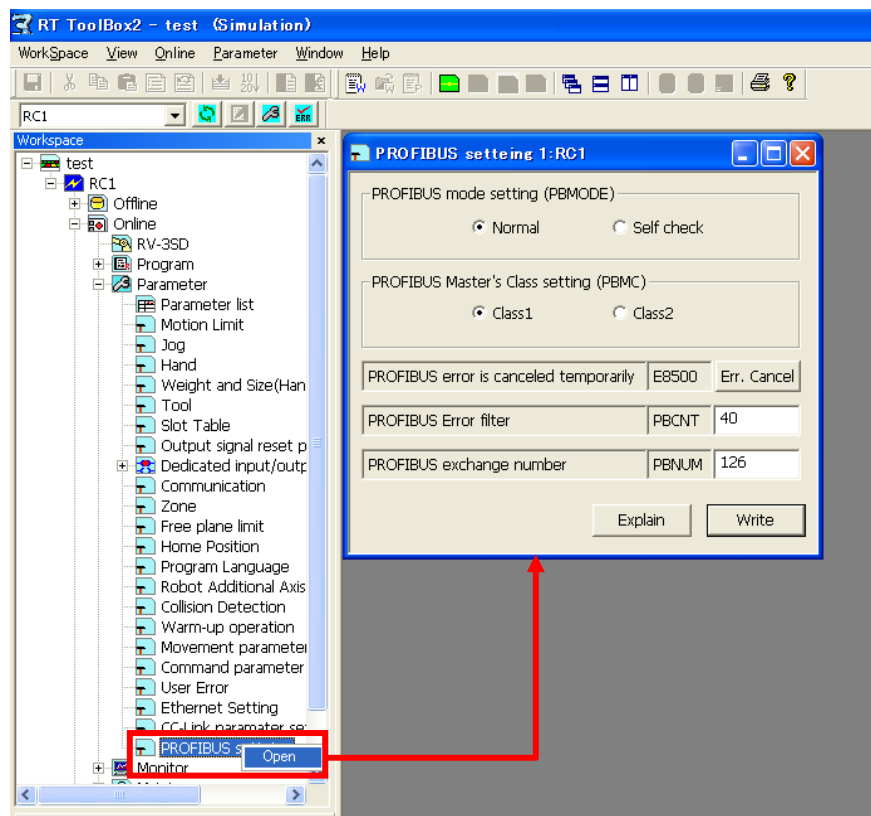

Figure 7-6 Opening PROFIBUS Setting Screen

## 7.4 Have A Try For It

### 7.4.1 Setting Dedicated Input/Output

Make settings for dedicated input/output as listed in the table. After changing the parameter settings, power the system off and on again.

For information about making these settings, refer to the "Instruction Manual - Detailed Description of Functions and Operation" which is separately issued.

Table 7-6 Setting Dedicated Input/Output

Parameter name	Input		Output	
	Meaning	Number	Meaning	No.
IOENA	Enable operating right.	2000	Operating right is being enabled.	2000
START	Start programs.	2001	Programs are being started.	2001
STOP2	Stop.	2002	During suspension.	2002
SLOTINIT	Program reset.	2003	Program selection is permitted.	2003
SRVON	Servo power on.	2004	Servo being turned on.	2004
SRVOFF	Servo power off.	2005		

### 7.4.2 About General-purpose Input/Output

General-purpose input/output, too, are accessible by using system variables for I/O, such as M\_In and M\_Out. However, you are not permitted to make such access as spans beyond the region used in PROFIBUS, like 1999, by using variables which access a plurality of bits, including M\_Inb, M\_Inw, M\_Outb, and M\_Outw. Ensure that your programming stays within the region ranging from 2000 and 3951.

Correct example: M\_In (2000), M\_Inb (2010), M\_Out (3000), M\_Outb (3010), etc.

Incorrect example: M\_Inb(1999), M\_Inw (5070), M\_Outb (1999), M\_Outw (1999), etc.

### 7.4.3 Examples of Robot Program (Using General-purpose I/O)

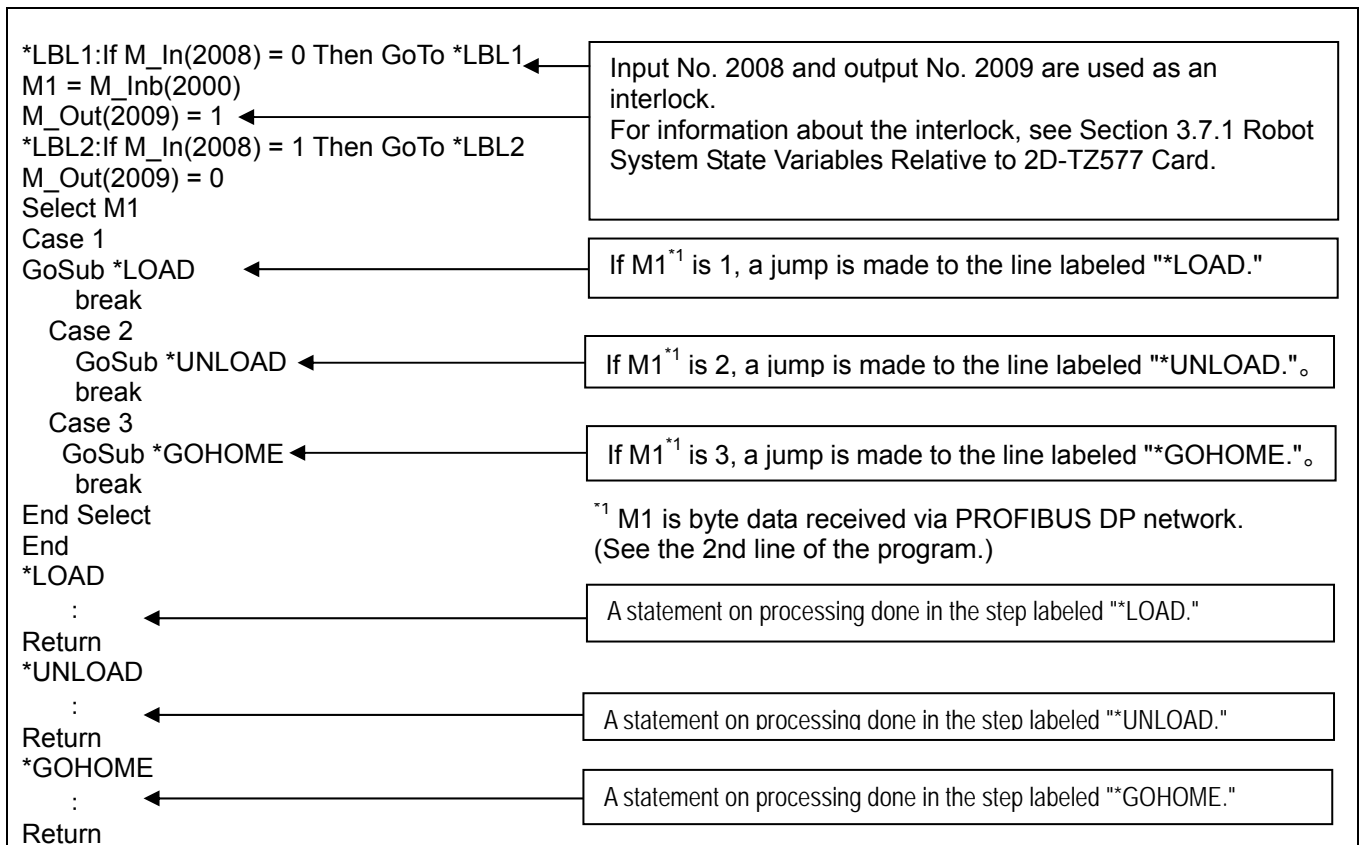

### 7.4.4 A Sample Program for Checking Input/Output

Shown below is a sample program which can be used for checking input/output on the 2D-TZ577 Card.  
Use this program during a checkup at startup or as otherwise required.

Table 7-7 Signal Alignment Conditions

Robot-side input (Master Station output)	Input 2000~3535 (equivalent to 96 words)
Robot-side output (Master Station input)	Output 2000~3535 (equivalent to 96 words)

Robot program specification

Input bits are copied in their entirety onto output bits.

[Robot Program - Example 1]

Input signals to the Robot are looped back in their entirety to output signals (for the purpose of bit check).

For M1 = 2000 To 3535

    M\_Out(M1) = M\_In(M1) ' Copied in the form of a variable for bit

Next M1

End

[Robot Program - Example 2]

Input signals to the Robot are looped back in their entirety to output signals (for the purpose of byte check).

For M1 = 2000 To 3535 Step 8

    M\_Outb(M1) = M\_Inb(M1) ' Copied in the form of a variable for byte

Next M1

End

[Robot Program - Example 3]

Input signals to the Robot are looped back in their entirety to output signals (for the purpose of word check).

For M1 = 2000 To 3535 Step 16

    M\_Outw(M1) = M\_Inw(M1) ' Copied in the form of a variable for word

Next M1

End

Run this program and check the looped-back signals on the side of the Master Station.

## 8. Troubleshooting

Check this section before concluding that your system is out of order.

### 8.1 A Listing of Errors

◆◆◆ An error number contains information as listed below ◆◆◆

□0000 \*

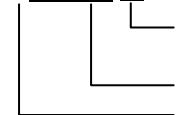

An error marked with an asterisk \* requires a power reset.  
Take a corrective action which is stated in the "Solutions" section of the table below.  
The type of error is indicated by a 4-digit number.  
Errors are sorted into three classifications:  
H: High-level error ..... Servo mechanism is shut down.  
L: Low-level error ..... Operation is suspended.  
C: Caution ..... Operation continues.

Table 8-1 A Listing of PROFIBUS-related Errors

Error No.	Causes and Solutions	
H.8500	Error message	PROFIBUS Initial error
	Cause	An error was detected in the hardware. The hardware may be at fault.
	Solution	Replace the 2D-TZ577 Card. When replacing the card, contact its manufacturer for advice.
H.8501	Error message	PROFIBUS watch dog timer error
	Cause	An error was detected in the hardware. The hardware may be at fault.
	Solution	Replace the 2D-TZ577 Card. When replacing the card, contact its manufacturer for advice.
H.8502*	Error message	Plural PROFIBUS cards are set.
	Cause	Only one card is accepted at any one time.
	Solution	Install only one card.
H.8503*	Error message	PROFIBUS/CC-Link cards are set.
	Cause	Either PROFIBUS or CC-Link card is accepted at any one time.
	Solution	Install either a PROFIBUS card or a CC-Link card.
H.8504	Error message	Either of the following messages is displayed: (1) PROFIBUS self-check error n (n = 1~7). (2) PROFIBUS cannot self-check
	Cause	An error was detected in the hardware. The hardware may be at fault.
	Solution	Replace the 2D-TZ577 Card. When replacing the card, contact its manufacturer for advice.
H.8505	Error message	Illegal param (PBMODE)
	Cause	PBMODE parameters are not defined validly.
	Solution	Correct PBMODE parameters. (0 - normal, 2 - self-diagnosis)
H.8506	Error message	Exchange number cannot be set.
	Cause	Power the system off and on again.
	Solution	If the error recurs, contact the manufacturer for advice.
H.8507	Error message	Illegal param (PBMC)
	Cause	PBMC parameters are not defined validly.
	Solution	Correct PBMODE parameters. (1 - Class 1, 2 - Class 2)

## 8 Troubleshooting

Error No.	Causes and Solutions	
H.8510	Error message	PROFIBUS exchange No. is wrong.
	Cause	Either of the following causes may be responsible: (1) Station numbers stored in the flash memory are outside the prescribed range. (2) An attempt was made to change to a station number being outside the prescribed range.
	Solution	Specify PBNUM parameter with numbers in the range of 1 to 125.
H.8520	Error message	PROFIBUS St.number write error.
	Cause	An attempt was made to change station numbers when rewriting was disabled.
	Solution	Enter "-1" in the "station number" box (robot parameter "PBNUM = -1") so that the existing station numbers are cleared.
	Error message	An attempt was made to change station numbers when "No_Add_Chg" had been specified with "true" during station number setting from Class 2 Master Station.
H.8530	Error message	PROFIBUS St.number write error.
	Cause	More than 60 consecutive rewrite attempts were made on the flash ROM.
	Solution	Replace the 2D-TZ577 Card. When replacing the card, contact its manufacturer for advice.
H.8540	Error message	PROFIBUS flash ROM access error.
	Cause	An anomaly in the hardware.
	Solution	Replace the 2D-TZ577 Card. When replacing the card, contact its manufacturer for advice.
H.8550	Error message	PROFIBUS master bureau's parameter is illegal
	Cause	Any one of the following causes may be responsible: (1) Parameters established at the Master Station are incorrect. (2) Set value for communication WDT is too long. (3) Value specified for minimum response time Min_Tsdr is outside the prescribed range.
	Solution	Check the slave parameter settings on the Master Station. (Refer to the instruction manual for Master Station.)
H.8560	Error message	PROFIBUS communication chip ERR
	Cause	An anomaly in the hardware.
	Solution	Replace the 2D-TZ577 Card. When replacing the card, contact its manufacturer for advice.
H.8570	Error message	PROFIBUS communication Time-out
	Cause	Timeout occurred in the communications with the Master Station.
	Solution	Check Master Station state and cable connections, and choose a longer communication WDT setting.
H.8580	Error message	PROFIBUS I/O composition error.
	Cause	Any one of the following causes may be responsible: (1) Data module is not of word type. (2) Swap set value is outside the prescribed range. (3) Data alignment mode set value is outside the prescribed range. (4) Number-of-data modules set value is outside the prescribed range. (5) Data module settings are outside the prescribed range. (6) Parameter setting station numbers are invalid.
	Solution	Check the slave parameter settings on the Master Station. (Refer to the instruction manual for Master Station.)

## 8.2 At the Occurrence of Error 8570

### (PROFIBUS Communication Timeout)

When this error occurred, take the corrective action suggested in the troubleshooting chart in Section 8.1. If the error still persists, check to see the following:

- (1) Is power to the Master Station unit on?
- (2) Is the Master Station functioning properly?  
\* H.8570 occurs unless the Master Station is up and running before power is turned on to the Robot Controller.
- (3) Is the Master Station properly connected?
- (4) Are the parameter settings on the Master Station consistent with those on the Robot Controller?
- (5) Doesn't any of the peripheral equipment contain a noise emission source?
- (6) If it is desired to ignore Error 8570, change E8570 parameter setting.

# 9. Appendix

## 9.1 Displaying Option Card Information

You can call up information about the option card on the screen using the RT ToolBox2 (Option) screen. Clicking Slotn(n=1~3):PROFIBUS under the Option Card entry on the Work Space tree lets you have information about the 2D-TZ577 Card displayed on a property window.

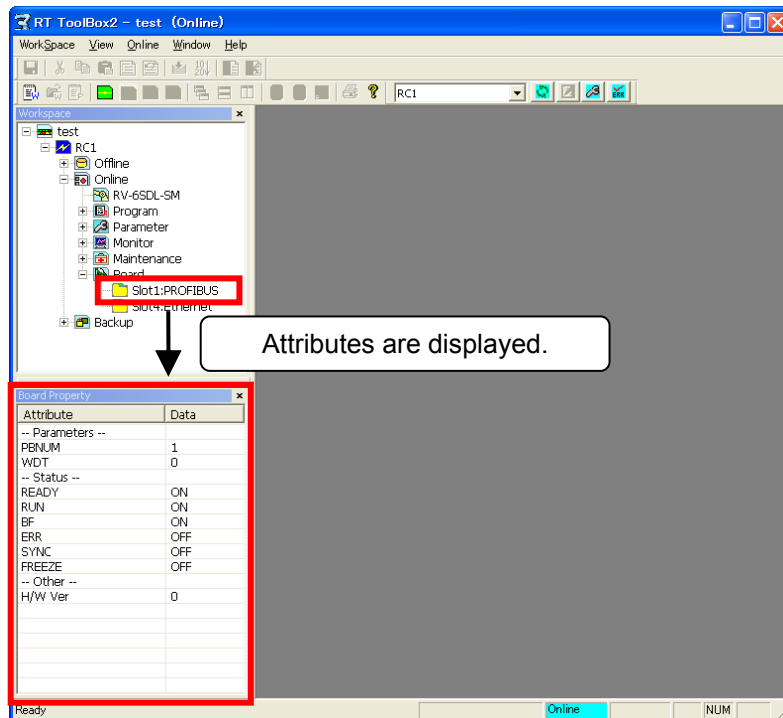

Figure 9-1 An Example of Option Card Information Displayed on RT ToolBox2 Window

Table 9-1 Information about 2D-TZ577 Card

Item of display	Example of information displayed	Meaning	Remark
Designation of card	PROFIBUS	Card name	
Card information	[PBNUM]	1	Number of station in action Station number: 0 to 125 (Default setting: 126(*1))
	[WDT]	5	Watchdog timer
	[Ready]	ON or OFF	Unit being in Ready state
	[RUN]	ON or OFF	Run state ON = normal, OFF = WDT error occurred
	[BF]	ON or OFF	BF state ON = Before data communications or communications error detected OFF = Communications proceeding normally
	[ERR.]	ON or OFF	Error-occurred state ON = Parameter setting error or unit error OFF = Communications proceeding normally
	[SYNC]	ON or OFF	SYNC-mode state ON = SYNC-mode state
	[FREEZE]	ON or OFF	FREEZE-mode state ON = FREEZE-mode state
	[H/W Ver]	0	Hardware version

(\*1) Station Number 126 gets the card isolated from a PROFIBUS network.



**HEADQUARTERS**

MITSUBISHI ELECTRIC EUROPE B.V. **EUROPE**  
 German Branch  
 Gothaer Straße 8  
**D-40880 Ratingen**  
 Phone: +49 (0)2102 / 486-0  
 Fax: +49 (0)2102 / 486-1120

MITSUBISHI ELECTRIC EUROPE B.V. **CZECH REPUBLIC**  
 Czech Branch  
 Avenir Business Park, Radlická 714/113a  
**CZ-158 00 Praha 5**  
 Phone: +420 (0)251 551 470  
 Fax: +420 (0)251-551-471

MITSUBISHI ELECTRIC EUROPE B.V. **FRANCE**  
 French Branch  
 25, Boulevard des Bouvets  
**F-92741 Nanterre Cedex**  
 Phone: +33 (0)1 / 55 68 55 68  
 Fax: +33 (0)1 / 55 68 57 57

MITSUBISHI ELECTRIC EUROPE B.V. **IRELAND**  
 Irish Branch  
 Westgate Business Park, Ballymount  
**IRL-Dublin 24**  
 Phone: +353 (0)1 4198800  
 Fax: +353 (0)1 4198890

MITSUBISHI ELECTRIC EUROPE B.V. **ITALY**  
 Italian Branch  
 Viale Colleoni 7  
**I-20041 Agrate Brianza (MI)**  
 Phone: +39 039 / 60 53 1  
 Fax: +39 039 / 60 53 312

MITSUBISHI ELECTRIC EUROPE B.V. **SPAIN**  
 Spanish Branch  
 Carretera de Rubí 76-80  
**E-08190 Sant Cugat del Vallés (Barcelona)**  
 Phone: 902 131121 // +34 935653131  
 Fax: +34 935891579

MITSUBISHI ELECTRIC EUROPE B.V. **UK**  
 UK Branch  
 Travellers Lane  
**UK-Hatfield, Herts. AL10 8XB**  
 Phone: +44 (0)1707 / 27 61 00  
 Fax: +44 (0)1707 / 27 86 95

MITSUBISHI ELECTRIC CORPORATION **JAPAN**  
 Office Tower "Z" 14 F  
 8-12,1 chome, Harumi Chuo-Ku  
**Tokyo 104-6212**  
 Phone: +81 3 622 160 60  
 Fax: +81 3 622 160 75

MITSUBISHI ELECTRIC AUTOMATION, Inc. **USA**  
 500 Corporate Woods Parkway  
**Vernon Hills, IL 60061**  
 Phone: +1 847 478 21 00  
 Fax: +1 847 478 22 53

**EUROPEAN REPRESENTATIVES**

GEVA **AUSTRIA**  
 Wiener Straße 89  
**AT-2500 Baden**  
 Phone: +43 (0)2252 / 85 55 20  
 Fax: +43 (0)2252 / 488 60

Koning & Hartman b.v. **BELGIUM**  
 Woluwelaan 31  
**BE-1800 Vilvoorde**  
 Phone: +32 (0)2 / 257 02 40  
 Fax: +32 (0)2 / 257 02 49

INEA BH d.o.o. **BOSNIA AND HERZEGOVINA**  
 Aleja Lipa 56  
**BA-71000 Sarajevo**  
 Phone: +387 (0)33 / 921 164  
 Fax: +387 (0)33 / 524 539

AKHNATON **BULGARIA**  
 4 Andrej Ljapchev Blvd. Pb 21  
**BG-1756 Sofia**  
 Phone: +359 (0)2 / 817 6004  
 Fax: +359 (0)2 / 97 44 06 1

AutoCont C.S. s.r.o. **CZECH REPUBLIC**  
 Technologická 374/6  
**CZ-708 00 Ostrava-Pustkovec**  
 Phone: +420 595 691 150  
 Fax: +420 595 691 199

B:TECH A.S. **CZECH REPUBLIC**  
 U Borové 69  
**CZ-58001 Havlíčkův Brod**  
 Phone: +420 (0)569 777 777  
 Fax: +420 (0)569-777 778

Beijer Electronics A/S **DENMARK**  
 Lykkegårdsvej 17, 1.  
**DK-4000 Roskilde**  
 Phone: +45 (0)46 / 75 76 66  
 Fax: +45 (0)46 / 75 56 26

Beijer Electronics OY **FINLAND**  
 Jaakonkatu 2  
**FIN-01620 Vantaa**  
 Phone: +358 (0)207 / 463 500  
 Fax: +358 (0)207 / 463 501

UTECO A.B.E.E. **GREECE**  
 5, Mavrogenou Str.  
**GR-18542 Piraeus**  
 Phone: +30 211 / 1206 900  
 Fax: +30 211 / 1206 999

AXICONT AUTOMATIKA KFT. **HUNGARY**  
 (ROBOT CENTER) Reitter F. U. 132  
**HU-1131 Budapest**  
 Phone: +36 1 / 412-0882  
 Fax: +36 1 / 412-0883

ALFATRADER Ltd. **MALTA**  
 99, Paola Hill  
**Malta- Paola PLA 1702**  
 Phone: +356 (0)21 / 697 816  
 Fax: +356 (0)21 / 697 817

HIFLEX AUTOM. TECHNIK B.V. **NETHERLANDS**  
 Woluweverstraat 22  
**NL-2984 CD Ridderkerk**  
 Phone: +31 (0)180 - 46 60 04  
 Fax: +31 (0)180 - 44 23 55

**EUROPEAN REPRESENTATIVES**

Koning & Hartman b.v. **NETHERLANDS**  
 Haarlerbergweg 21-23  
**NL-1101 CH Amsterdam**  
 Phone: +31 (0)20 / 587 76 00  
 Fax: +31 (0)20 / 587 76 05

Beijer Electronics AS **NORWAY**  
 Postboks 487  
**NO-3002 Drammen**  
 Phone: +47 (0)32 / 24 30 00  
 Fax: +47 (0)32 / 84 85 77

MPL Technology Sp. z o.o. **POLAND**  
 Ul. Krakowska 50  
**PL-32-083 Balice**  
 Phone: +48 (0)12 / 630 47 00  
 Fax: +48 (0)12 / 630 47 01

SIRIUS TRADING & SERVICES SRL **ROMANIA**  
 Aleea Lacul Morii Nr. 3  
**RO-060841 Bucuresti, Sector 6**  
 Phone: +40 (0)21 / 430 40 06  
 Fax: +40 (0)21 / 430 40 02

INEA SR d.o.o. **SERBIA**  
 Izletnicka 10  
**SER-113000 Smederevo**  
 Phone: +381 (0)26 / 617 163  
 Fax: +381 (0)26 / 617 163

CS MTrade Slovensko, s.r.o. **SLOVAKIA**  
 Vajanského 58  
**SK-92101 Piestany**  
 Phone: +421 (0)33 / 7742 760  
 Fax: +421 (0)33 / 7735 144

INEA d.o.o. **SLOVENIA**  
 Stegne 11  
**SI-1000 Ljubljana**  
 Phone: +386 (0)1 / 513 8100  
 Fax: +386 (0)1 / 513 8170

Beijer Electronics Automation AB **SWEDEN**  
 Box 426  
**SE-20124 Malmö**  
 Phone: +46 (0)40 / 35 86 00  
 Fax: +46 (0)40 / 35 86 02

Robotronic AG **SWITZERLAND**  
 Schlachthofstrasse 8  
**CH-8406 Winterthur**  
 Phone: +41 52 203 35 65  
 Fax: +41 52 203 35 66

GTS **TURKEY**  
 Bayraktar Bulvari Nutuk Sok. No:5  
**TR-34775 Yukari Dudullu-Umraniye-ISTANBUL**  
 Phone: +90 (0)216 526 39 90  
 Fax: +90 (0)216 526 39 95

CSC Automation Ltd. **UKRAINE**  
 4-B, M. Raskovoyi St.  
**UA-02660 Kiev**  
 Phone: +380 (0)44 / 494 33 55  
 Fax: +380 (0)44 / 494-33-66

**MIDDLE EAST REPRESENTATIVE**

ILAN & GAVISH Ltd. **ISRAEL**  
 24 Shenkar St., Kiryat Arie  
**IL-49001 Petaah-Tiqva**  
 Phone: +972 (0)3 / 922 18 24  
 Fax: +972 (0)3 / 924 0761

**AFRICAN REPRESENTATIVE**

CBI Ltd. **SOUTH AFRICA**  
 Private Bag 2016  
**ZA-1600 Isando**  
 Phone: +27 (0)11 / 928 2000  
 Fax: +27 (0)11 / 392 2354