



Changes for the Better

MITSUBISHI INDUSTRIAL ROBOT

MELFA RH-6SDH/12SDH/18SDH Series



RH-12SDH
RH-18SDH



RH-6SDH

MELFA
RH-SDH series

Mitsubishi Electric Corporation Nagoya Works is a factory certified for ISO14001 (standards for environmental management systems) and ISO9001 (standards for quality assurance management systems)



The Ultimate Series of Powerful Mitsubishi Robots Offering

- A new high performance controller design offers faster speed and greater accuracy.
- Enhanced compatibility with the Mitsubishi's family of automation products improves versatility.
- Compact but rigid arm designs are durable and flexible for applications in all industries.
- Dedicated Mitsubishi servo technology has been designed for each model to optimize overall performance.

MELFA RH-SDH series

CR1D-761

CR2D-741

CR2D-751

Applicable models



RH-6SDH



RH-12SDH



RH-18SDH

Features

1 Improved Productivity

■ Shorter takt time

With a new, high-performance controller, I/O's and programs can be processed at high speed. This allows the takt time to be reduced by as much as 15%.

■ High operation accuracy [High-rigidity arm, active gain control]

The robot posture and load are monitored to adjust the servo gain and filter in real time. This achieves higher accuracy.

■ Direct connection to the GOT

The robot controller can be connected directly to our GOT-1000-series display via Ethernet. This achieves sequencer-free operation and ultimately reduces cost.

■ All models come standard with advanced functions

Control of additional axes, tracking function and Ethernet, which were all provided as options with the S series, are now standard features. You can save on the costs of options to reduce the overall system cost.

2 Improved Operability

Adoption of a new HMI (Human Machine Interface) results in significant improvement of operability.

■ New function wizards

Wizards for special functions such as additional axes, tracking and collision detection are included in the PC tools. These wizards reduce the time needed for startup, adjustment and maintenance.

■ New teaching pendant with graphical interface

The new teaching pendant [R56TB] offers significantly improved operability through its GUI reduces the time needed for startup, adjustment and maintenance.

3 Safety

■ Compliance with ISO-10218 (2006)

The RV-SD series helps your equipment as a whole comply with the safety standards.



■ Compliance with various standards

The RV-SD series complies with the European Machinery Directive (CE) and UL Standard. (UL-compatible models are limited to custom specifications.)

4 Backward Compatibility

■ Fully compatible with S-series robot systems

Robot programs and I/O maps for S-series robots can be used 100%.

Lineup

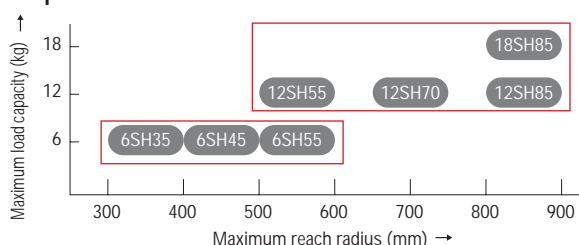

Model Structure

Robot series	Arm length [mm]	Up/down axis movement range [mm]				Connection controller
		170	200	300	350	
RH-6SDH series	350	RH-6SDH3517M/C	RH-6SDH3520	-	-	CR1D-761
	450	RH-6SDH4517M/C	RH-6SDH4520	-	-	
	550	RH-6SDH5517M/C	RH-6SDH5520	-	-	
RH-12SDH series	550	-	-	RH-12SDH5530M/C	RH-12SDH5535	CR2D-741
	700	-	-	RH-12SDH7030M/C	RH-12SDH7035	
	850	-	-	RH-12SDH8530M/C	RH-12SDH8535	
RH-18SDH series	850	-	-	RH-18SDH8530M/C	RH-18SDH8535	CR2D-751

*1: Take note that on the models of environment-resistant specifications (C: Clean specification, M: Mist specification), the operating range of the vertical axis is smaller than on the standard models.

*2: The environment-resistant specifications (clean/mist specifications) are factory-set custom specifications. For the approximate timeframe for delivery, contact the Mitsubishi Electric dealer or sales agent near you.

New Functionality and Performance

Functions

1 New teaching pendant (optional)

Improved display performance and operability

- Simple teaching pendant [R32TB]
- Five times greater display performance (vs. R28TB)
- Ergonomic design improves operability.
- IP65 Protection



2 New high-functional teaching pendant (optional)

No need to bring a PC to the site

- High-functional teaching pendant [R56TB] [VGA (640 x 480) touch panel] adopted
- Can utilize HMI tools equivalent to the RT-Tool Box on the teaching pendant.
- Can utilize USB memory to back up controller data.
- IP65 Protection



3 Additional axis function

No need for dedicated control device. Additional axes can be controlled with robot programs. This helps keep the system cost low.

- Controlling the robot's traveling axes and turntable.
- Up to 8 axes can be controlled in addition to the robot.
- Standard function
- Utilizes Mitsubishi MR-J3□B servos for additional axes.

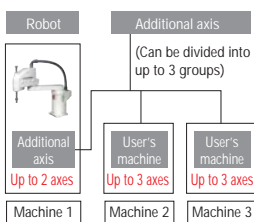

4 Synchronized outputs from additional axes

Improved safety of the entire system

- A signal is output from the auxiliary contacts for the main circuit contactor in the robot controller. The auxiliary contacts allow the servo amplifier contactor of each additional axis to synchronize with the robot servo status.
- This contact signal is output redundantly, which improves the safety of your equipment and makes it easy for the entire equipment to comply with the safety standards.

5 Tracking function

Improved process takt. No need for positioning device. This helps keep the system cost low.

- The robot can be operated without stopping the conveyor.
- Robot programs can be easily written using MELFA-BASIC-V language.
- Standard function

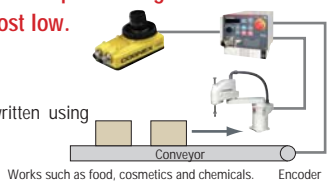

6 GOT connection

No need for GOT connection ladder

- The robot can be controlled directly from the GOT1000. (A dedicated robot screen must be created.)

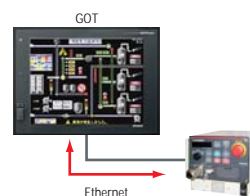

7 Active gain control

Improved tracking accuracy and vibration-damping performance

- The motor is tuned for optimal control automatically based on the operating position, posture and load condition of the robot.

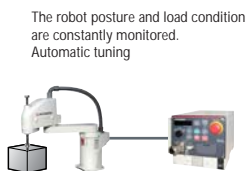

8 Ensuring of safety based on operation by two persons

[Enabling-device input function]

- Allows for connection of 3-position enabling devices to protect the robot system and multiple persons from danger.
- Since multiple operators must always be coordinated, safety improves.
- Redundant devices



9 New emergency-stop I/O function

[Emergency-stop output function]

- Even when the robot controller power is cut off, you can still stop the peripherals by pressing the emergency stop switch on the panel or teaching pendant.

- These I/Os are all provided redundantly.

[Robot error output]

- If the robot generates an error, a safety contact signal is output in addition to an applicable I/O signal output on conventional models.

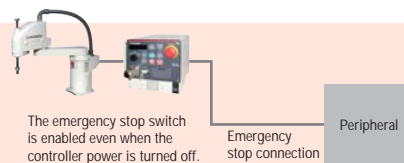

Applications

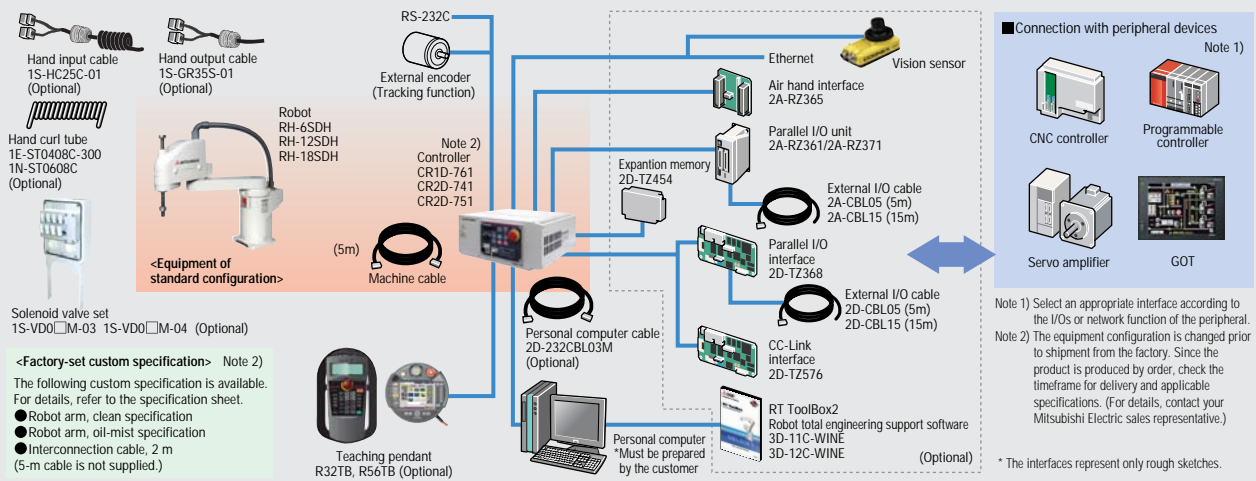

New Functionality and Performance

Robot Arm Outside Dimension/Movement Range Diagrams

RH-6SDH

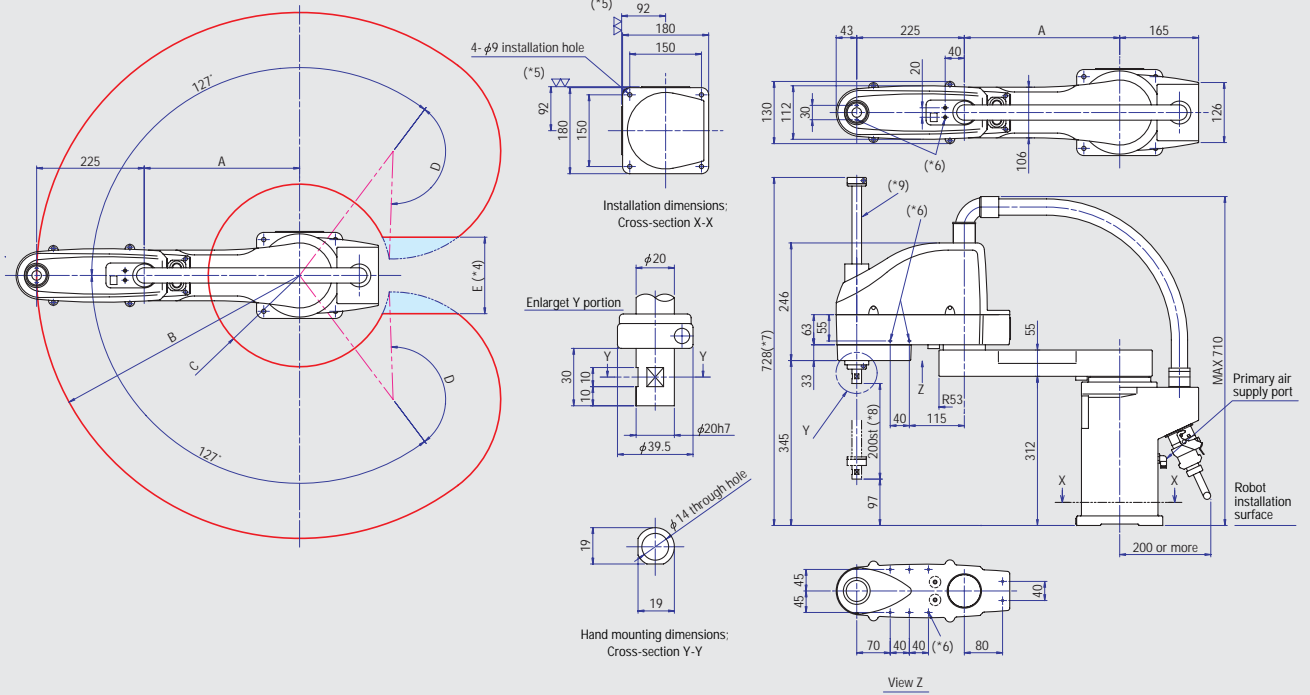

Variable dimensions

Robot series	A	B	C	D	E (*4)
RH-6SDH35	125	R350	R159	137°	210
RH-6SDH45	225	R450	R136	145°	210
RH-6SDH55	325	R550	R191	145°	160

- *4: Limited area according to the drawing of operating ranges.
- *5: Reference machined surface used at the time of installation.
- *6: Screw hole (M4) used for affixing user wiring and piping.
- *7: 788 on the oil-mist and clean specification models.
- *8: 170 st on the oil-mist and clean specification models.
- *9: On the oil-mist and clean specification models, bellows are installed in the exposed areas (top and bottom) of the ball screw spline.

RH-12SDH/RH-18SDH

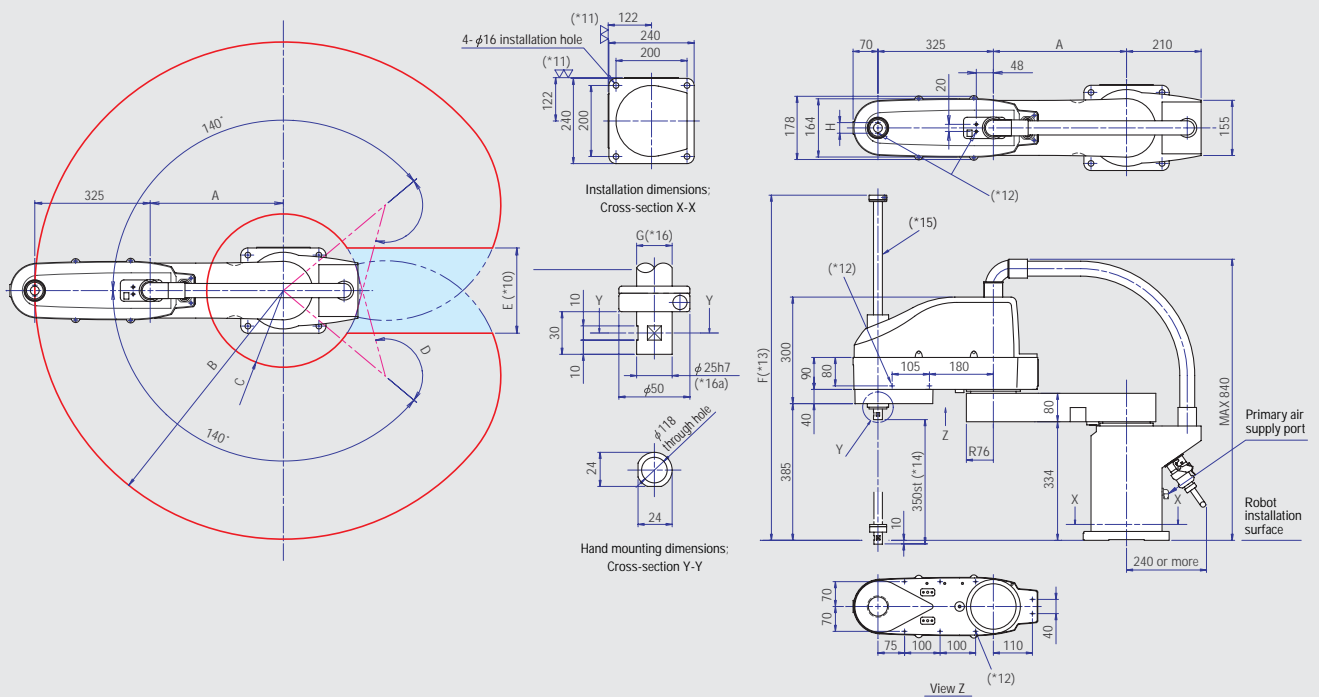

Variable dimensions

Robot series	A	B	C	D	E (*10)	F (*13)	G	H
RH-12SDH55	225	R550	R191	145°	240	972	φ25	30
RH-12SDH70	375	R700	R216	145°	240	972	φ25	30
RH-12SDH85	525	R850	R278	153°	-	972	φ25	30
RH-18SDH85	525	R850	R278	153°	-	967	φ32	40

- *10: Limited area according to the drawing of operating ranges.
- *11: Reference machined surface used at the time of installation.
- *12: Screw hole (M4) used for affixing user wiring and piping.
- *13: 1027 on the RH-12SDH-series models, and 999 on the RH-18SDH-series models, of oil-mist or clean specification.
- *14: 300 st on the oil-mist and clean specification models.
- *15: On the oil-mist and clean specification models, bellows are installed in the exposed areas (top and bottom) of the ball screw spline.
- *16: G is φ25 on the RH-12SDH-series models, and φ32 on the RH-18SDH-series models. The outer shaft shape of the hand installation flange is the same with both series. (*16a)

Specifications

Robot Arm

Type	Unit	RH-6SDH35zze	RH-6SDH45zze	RH-6SDH55zze	RH-12SDH55zze	RH-12SDH70zze	RH-12SDH85zze	RH-18SDH85zze
Machine class		En (Refer to Table 1.)						
Installation		Floor type						
Degrees of freedom		4						
Structure		Horizontal, multiple-joint type						
Drive method		AC servo motor						
Position detection method		Absolute encoder						
Maximum load capacity	kg	6		12		18		
Arm length	No. 1 arm	125	225	325	225	375	525	
	No. 2 arm	225						
Maximum reach radius (No. 1 arm + No. 2 arm)		350	450	550	550	700	850	
Operating range	J1	254 (±127)			280 (±140)			
	J2	274 (±137)	290 (±145)		290 (±145)		306 (±153)	
	J3(Z)	Z (Refer to Table 1.)						
	J4(θ)	720 (±360)						
Maximum speed	J1	375			360		288	
	J2	612			412.5			
	J3(Z)	1,177			1,300		1,200	
	J4(θ)	2,411			1,500			
Maximum composite speed *17	mm/sec	6,473 (4,694)	7,128 (5,349)	7,782 (6,003)	10,555 (5,796)	11,498 (6,738)	11,221 (6,612)	
Cycle time *18	sec	0.42	0.42	0.43	0.43	0.44	0.45	0.53
Allowable moment of inertia (rating)	kg·m ²	0.04(0.01)			0.1 (0.02)			
Position repeatability	X-Y composite	±0.02			±0.02	±0.025		
	J3(Z)	±0.01			±0.01			
	J4(θ)	±0.02			±0.03			
Ambient temperature	°C	0 to 40						
Mass	kg	20	21	41	43	45	47	
Tool wiring *19		Hand: 8 input points / 8 output points, 8 spare lines: AWG#24 (0.2mm ²)						
Tool pneumatic pipes		φ6 x 2pcs						
Supplied air pressure	MPa	0.5±10%						
Protection class/Clean specifications		Protect (Refer to Table 1.)						

Table 1: Relationship Among the Robot Series, Environment Specifications and Up/Down Axis Movement Range (Z Stroke)

Robot series	Up/down axis movement range		Protection specifications		Protection class/Clean specifications (Protect)
	(Z)	Symbol (model notation: zz)	(En)	Symbol (model notation: e)	
RH-6SD series	200 (97 to 297)	20	Standard	Blank	IP20
	170 (97 to 267)	17	Oilmist proof	M	IP54
	170 (97 to 267)	17	Clean	C	Class10 (0.3μm)
RH-12/18SD series	350 (-10 to 340)	35	Standard	Blank	IP20
	300 (-10 to 290)	30	Oilmist proof	M	IP54
	300 (-10 to 290)	30	Clean	C	Class10 (0.3μm)

*17: When J1, J2 and J4 are composited. The value in parentheses assumes composition of J1 and J2.

*18: Based on a load capacity of 2 kg for the RH-6/12SDH (or load capacity of 5 kg for the RH-18SDH). The cycle time may increase if specific requirements apply such as high work positioning accuracy, or depending on the operating position. (The cycle time is based on back-and-forth movement over a vertical distance of 25 mm and horizontal distance of 300 mm.)

*19: If the hand output is used, the air hand interface (optional) is required.

Controller

Type	Unit	CR1D-761	CR2D-741/751	CR3D-741M/751M
Path control method		PTP control and CP control		
Number of axes controlled		Up to 4 axes simultaneously	Up to 4 axes simultaneously	Up to 4 axes simultaneously. Up to 8 additional axes can be controlled in addition to the above.
Robot language		MELFA-BASIC V		
Position teaching method		Teaching method, MDI method		
Memory capacity	Number of teaching points	13,000		
	Number of steps	26,000		
	Number of programs	256		
External input/output	General-purpose I/O	0 input/0 output (Up to 256/256 when options are used)		
	Dedicated I/O	Assigned according to general-purpose I/O.		
	Hand open/close	8 inputs/0 output (8/8 when the pneumatic hand interface is used)		
	Emergency stop input	1 (2 contacts are supported)		
	Door switch input	1 (2 contacts are supported)		
	Enabling device input	1 (2 contacts are supported)		
	Emergency stop output	1 (2 contacts are supported)		
	Mode output	1 (2 contacts are supported)		
	Robot error output	1 (2 contacts are supported)		
Interface	Synchronization of additional axes	1 (2 contacts are supported)		
	RS-232C	1 (for the connection of a personal computer, vision sensor, etc.)		
	Ethernet	1 (dedicated teaching pendant port), 1 (for customer)		
	USB	10BASE-T/100BASE-T		
Additional-axis interface	slots	1 (Version 1.1 device functions only)		
	channels	1(SSCNET III)		
Operating temperature range	°C	0 to 40		
Relative humidity	%RH	45 to 85		
Power supply	Input voltage range	Single-phase, AC 180 to 253 *22		
	Power capacity *20	1.0 (not including rush current)	2.0 (not including rush current)	3.0 (not including rush current)
External dimensions (including legs)	mm	240 (W) x 290 (D) x 200 (H)	470 (W) x 400 (D) x 200 (H)	450 (W) x 440 (D) x 625 (H) *23
Weight	kg	Approx. 9		
Structure		Self-contained floor type/open structure	Self-contained floor type/open structure	Self-contained floor type/sealed structure [IP54]
Grounding *21	Ω	100 or less (class D grounding)		

*20: The power capacity indicates the rating for normal operation. Take note that the power capacity does not include the current being input when the power is turned on. The power capacity is only a rough guide and whether or not operation can be guaranteed depends on the input power-supply voltage.

*21: Grounding works are the customer's responsibility.

*22: The rate of fluctuation of power-supply voltage is within 10%.

*23: 615 (H) for the caster specification.

Controller – External Dimensions

CR1D-700 series

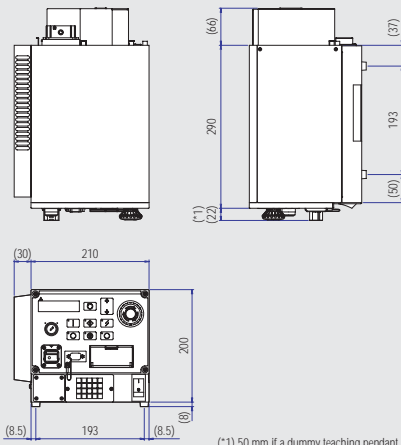

(*1) 50 mm if a dummy teaching pendant plug is installed

CR2D-700 series

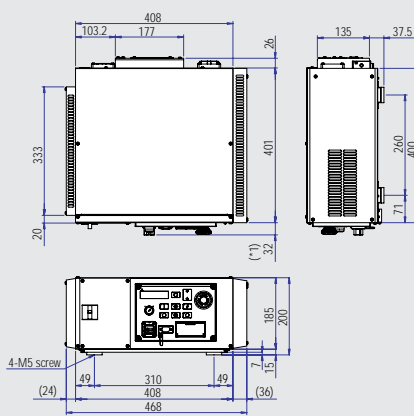

CR3D-700 series

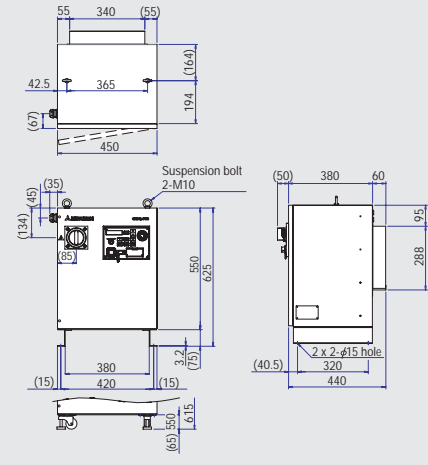

Dimensions of caster specification (factory-set customer specification)

Configurations Options

Classification	Name	Type	Specification overview	Compatibility	Model compatibility	
					RH-6SDH	RH-12/18SDH
Robot arm	Solenoid valve set	1S-VD0□M-03	1 to 4 valves connected / With solenoid valve cable (with oil mist box)	○	×	○
		1S-VD0□M-04	1 to 4 valves connected / With solenoid valve cable (with oil mist box)	○	○	×
	Hand output cable	1S-GR35S-02	4 valves connected with one end not treated (length: 350mm)	○	○	○
	Hand input cable	1S-HC25C-02	8-point type with splash-proof grommet (length: 1,200mm)	○	○	○
	Hand curl tube	1E-ST0408C-300	φ4-4 valves connected type	○	○	×
		1N-ST0608C	φ6-4 valves connected type	○	×	○
Machine cable, for extension/fixed	1S-□□CBL-01	Extension type / Extended length: 5m, 10m, 15m	○	×	○	
		Extension type / Extended length: 5m, 10m, 15m	○	○	×	
	1S-□□LCBL-01	Extension type / Extended length: 5m, 10m, 15m	○	×	○	
Machine cable, for extension/flexible	1S-□□LCBL-03	Extension type / Extended length: 5m, 10m, 15m	○	○	×	
		Extension type / Extended length: 5m, 10m, 15m	○	○	×	
Controller	Simple teaching pendant	R32TB(-**)	7m: Standard / 15m: Custom ("-15" is specified in the model name)	New	○	○
	High-function teaching pendant	R56TB(-**)	7m: Standard / 15m: Custom ("-15" is specified in the model name)	New	○	○
	Air hand I/F (sink/source)	2A-RZ365/2A-RZ375	8 output points, used exclusively for hand	○	○	○
	Parallel I/O unit (sink/source)	2A-RZ361/2A-RZ371	32 output points / 32 input points	○	○	○
	External I/O cable	2A-CBL**	CBL05: 5m CBL15: 15m(One end not treated, for 2A-RZ361/2A-RA371)	○	○	○
	Parallel I/O interface (sink)	2D-TZ368	32 output points / 32 input points	New	○	○
	External I/O cable	2D-CBL**	CBL05: 5m CBL15: 15m(One end not treated, for 2D-TZ368)	New	○	○
	CC-Link interface	2D-TZ576	CC-Link intelligent device station, Version 2.0, 1 to 4 stations	New	○	○
	Additional memory	2D-TZ454	User program area with additional memory: 2MB	New	○	○
	RT ToolBox2	3D-11C-WINE	With simulation function (CD-ROM)	New	○	○
	RT ToolBox2 mini	3D-12C-WINE	Simple version (CD-ROM)	New	○	○
	Personal computer cable	2D-232CBL03M	For PC-AT compatible machine, 3m	New	○	○
Service part	Backup battery	A6BAT	Installed in the robot arm (Quantity: 5pcs)	○	○	○
		O6BAT	Installed in the controller (Quantity: 1pc)	New	○	○

(*) <Compatibility with conventional models> New: New option / ○ : Option for conventional models can be used



Governmental export permits are required for the export of products used for strategic materials and service.