



(4) CN10

Device	Symbol	Pin No.	Function/Application	I/O
A-axis shutdown 2	SDI2A+ SDI2A-	3A 3B	Connect this device to a safety switch for A-axis driving device. Input a same signal as A-axis shutdown 1. STO state (base shutdown): Open between SDI2A+ and SDI2A-. STO release state (in driving): Close between SDI2A+ and SDI2A-.	DI-1
B-axis shutdown 2	SDI2B+ SDI2B-	4A 4B	Connect this device to a safety switch for B-axis driving device. Input a same signal as B-axis shutdown 1. STO state (base shutdown): Open between SDI2B+ and SDI2B-. STO release state (in driving): Close between SDI2B+ and SDI2B-.	DI-1
A-axis EMG start/reset	SRESA+ SRESA-	1A 1B	Signal for releasing STO state (base shutdown) on A-axis driving device. Releases STO state (base shutdown) on A-axis driving device by switching between SRESA+ and SRESA- from ON (connected) to OFF (opened).	DI-1
B-axis EMG start/reset	SRESB+ SRESB-	2A 2B	Signal for releasing STO state (base shutdown) on B-axis driving device. Releases STO state (base shutdown) on B-axis driving device by switching between SRESB+ and SRESB- from ON (connected) to OFF (opened).	DI-1
A-axis SDO2	SDO2A+ SDO2A-	6A 6B	Outputs STO2 to A-axis driving device. Outputs a same signal as A-axis SDO1. STO state (base shutdown): Between SDO2A+ and SDO2A- is opened. STO release state (in driving): Between SDO2A+ and SDO2A- is closed.	DO-1
B-axis SDO2	SDO2B+ SDO2B-	5A 5B	Outputs STO2 to B-axis driving device. Outputs a same signal as B-axis SDO1. STO state (base shutdown): Between SDO2B+ and SDO2B- is opened. STO release state (in driving): Between SDO2B+ and SDO2B- is closed.	DO-1
Control circuit power	+24V	7A	Connect + side of 24VDC.	
Control circuit power GND	0V	7B	Connect - side of 24VDC.	
A-axis STO state	TOFA	8A	TOFA is internally connected with TOF2A.	
B-axis STO state	TOFB	8B	TOFB is internally connected with TOF2B.	

8.2 Interfaces

(1) Detailed description of interfaces

(a) Digital input interface (CN9, CN10 connector)

Give a signal with a relay or open collector transistor.

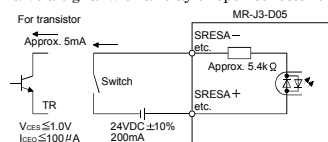

(b) Digital output interface

A lamp, relay or photocoupler can be driven. Install a diode (D) for an inductive load, or install an inrush current suppressing resistor (R) for a lamp load. (Rated current: 40mA or less, maximum current: 50mA or less, inrush current: 100mA or less) A maximum of 2.6V voltage drop occurs in the MR-J3-D05.

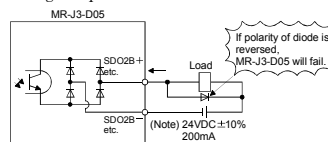

Note. If the voltage drop (maximum of 2.6V) interferes with the relay operation, apply high voltage (up to 26.4V) from external source.

(2) Source I/O interfaces (CN9, CN10 connector)

In this servo amplifier, source type I/O interfaces can be used. Perform wiring according to the following interfaces.

(a) Digital input interface

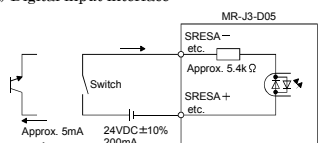

(b) Digital output interface

A maximum of 2.6V voltage drop occurs in the servo amplifier.

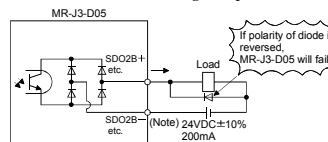

Note. If the voltage drop (maximum of 2.6V) interferes with the relay operation, apply high voltage (up to 26.4V) from external source.

8.3 Wiring CN9 and CN10 connectors

Handle with the tool with care when connecting wires.

(1) Wire strip

- Use wires with size of AWG#20 to #24 (0.22 to 0.5mm<sup>2</sup>) (recommended electric wire: UL1007) and strip the wires to make the strip length 7.0±0.3mm. Confirm the strip length with gauge, etc. before using the wires.
- If the stripped wires are bent, feazed or too thick due to twisting too much, fix the wires by twisting lightly, etc. Then, confirm the strip length before using the wires. Do not use excessively deformed wires.
- Smooth out the wire surface and stripped insulator surface.

(2) Connecting wires

It works when wires is connected with the Receptacle assembly pulled out from the header connector with out fail. There is danger of damaging the connector and the printed board when working with the connector mated.

(a) Using extraction tool (1891348-1 or 2040798-1)

1) External dimensions and mass

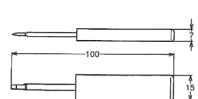

[Unit: mm]

Mass : Approx. 20g

2) Connecting wires

- Confirm the model number of the housing, contact and tool to be used.
- Insert the tool diagonally into the receptacle assembly.
- Insert the tool until it hits the surface of the receptacle assembly. At this stage, the tool is vertical to the receptacle assembly.

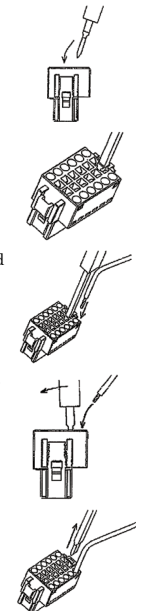

- Insert wires in the wiring hole till the end. The wires should be slightly twisted in advance to prevent it from being feazed.

It is easy to insert the wire if the wire is inserted diagonally while twisting the tool.

- Remove the tool.

(b) Using a screwdriver

Do not put excessive force, and be cautious when working.

1) Adjusting driver

Diameter: 2.3±0.05mm  
Length: 120mm MAX  
Width: 2.3mm, Blade thickness: 0.25mm  
Angle in tip of the blade: 18±1 degrees

Diameter: 2.3±0.05mm  
Length: 120mm MAX  
Width: 2.5mm, Blade thickness: 0.3mm  
Angle in tip of the blade: 12±1 degrees

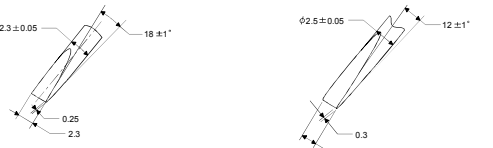

Screwdriver diameter φ2.3mm      Screwdriver diameter φ2.5mm

2) Connecting wires

- Insert a screwdriver in the front slot a little diagonally, and depress the spring. While depressing the spring, insert the wires until they hit the end. Note that the housing and spring may be damaged if the screwdriver is inserted strongly. Never insert the screwdriver in the wire hole. Otherwise, the connector will be damaged.
- Pull the screwdriver out while pressing the wires. Connecting wires is completed.
- Pull the wires lightly, and confirm that the wires are surely connected.
- To remove the wires, depress the spring by the screwdriver in the same way as connecting wires, and then pull the wires out.

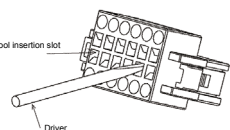

(2) Connector insertion

Insert the connector all the way straight until you hear or feel clicking. When removing the connector, depress the lock part completely before pulling out. If the connector is pulled out without depressing the lock part completely, the housing, contact and/or wires may be damaged.

(3) Compatible wire

Compatible wire size is listed below.

Wire size	
mm <sup>2</sup>	AWG
0.22	#24
0.34	#22
0.50	#20

(4) Others

- Fix a wire tie at least distance of "A" × 1.5 Min away from the end of the connector.

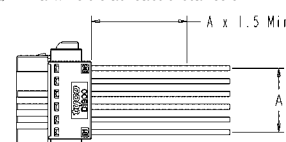

- Be sure that wires are not pulled excessively when the connector is inserted.

8.4 Wiring FG

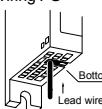

- Wire range
- Single wire : φ0.4 mm to φ1.2 mm (AWG 26 to AWG 16)
- Stranded wire : 0.2 mm<sup>2</sup> to 1.25 mm<sup>2</sup> (AWG 24 to AWG 16), wire φ0.18 mm or more

9. LED DISPLAY

I/O status, fault and power ON/OFF are displayed with LED for each A-axis and B-axis.

LED	Definition	LED	
		Column A	Column B
SRES	Monitor LED for start/reset OFF: The start/reset is off.(The switch contact is opened.) ON: The start/reset is on.(The switch contact is closed.)	A-axis	B-axis
SDI1	Monitor LED for shutdown 1 OFF: The shutdown 1 is off.(The switch contact is opened.) ON: The shutdown 1 is on.(The switch contact is closed.)		
SDI2	Monitor LED for shutdown 2 OFF: The shutdown 2 is off.(The switch contact is opened.) ON: The shutdown 2 is on.(The switch contact is closed.)		
TOF	Monitor LED for STO state OFF: In STO state ON: Not in STO state		
SDO1	Monitor LED for SDO1 OFF: In STO state ON: Not in STO state		
SDO2	Monitor LED for SDO2 OFF: In STO state ON: Not in STO state		
SW	Monitor LED for confirming shutdown delay setting OFF: The settings of SW1 and SW2 do not match. ON: The settings of SW1 and SW2 match.		
FAULT	FAULT LED OFF: Normal operation (STO monitoring state) ON: Fault has occurred.		
POWER	Power OFF: Power is not supplied to MR-J3-D05. ON: Power is being supplied to MR-J3-D05.		

10. ROTARY SWITCH SETTING

Rotary switch is used to shut off the power after control stop by SS1 function. Set the delay time for STO output after STO shut off switch is pressed. Set same setting for SW1 and SW2, and set the rotary switch setting according to the delay time in the table below.

Setting cannot be changed while power is ON. Notify users that setting cannot be changed by putting a seal or by another method so that end users will not change the setting after the shipment.

0 to F in the following table is the set value of the rotary switches (SW1 and SW2).

	Rotary switch setting and delay time at A/B-axis [s]					
	B axis					
A axis	0s	1.4s	2.8s	5.6s	9.8s	30.8s
0s	0	1	2	—	3	4
1.4s	—	—	5	—	6	7
2.8s	—	—	8	—	9	A
5.6s	—	—	—	—	B	C
9.8s	—	—	—	—	D	E
30.8s	—	—	—	—	—	F

11. TROUBLESHOOTING

When power is not supplied or FAULT LED turns on, refer the following table and take the appropriate action.

Event	Definition	Cause	Action
Power is not supplied.	Power LED does not turn on although power is supplied.	1. 24VDC power supply is faulty. 2. Wires between MR-J3-D05 and 24VDC power supply are cut or are in contact with other wires. 3. MR-J3-D05 is faulty.	Change the 24VDC power supply. Check the wiring. Change the MR-J3-D05.
FAULT LED is on.	FAULT LED of A-axis or B-axis is on, and will not turn off.	1. Mismatch of delay time setting. 2. Switch input error 3. TOF signal error 4. MR-J3-D05 is faulty.	Check the settings of the rotary switch. Check the wiring or sequence of the input signals. Check the connection with the servo amplifier. Change the MR-J3-D05.

12. OUTLINE DRAWINGS

MR-J3-D05

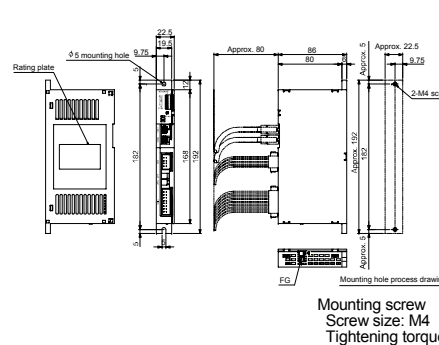

[Unit: mm]

Mounting screw  
Screw size: M4  
Tightening torque: 1.2 [N · m]

Mass: 0.2 [kg]

13. INSTALLATION

Follow the instructions in this chapter and install MR-J3-D05 in the specified direction. Leave clearances between MR-J3-D05 and other equipment including the control box.

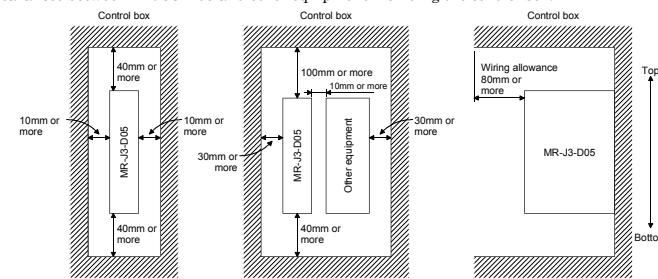

14. COMBINATIONS OF CABLE/CONNECTOR

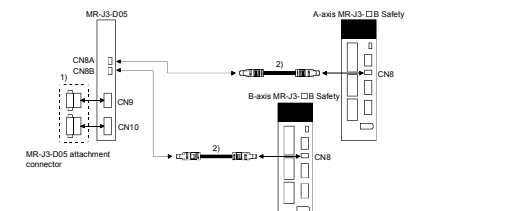

No.	Product	Model	Description
1)	Connector	MR-J3-D05 attachment connector	For CN9 Connector: 1-1871940-4 (Tyco Electronics) For CN10 Connector: 1-1871940-8 (Tyco Electronics)
2)	STO cable	MR-D05UDLCM Cable length: 0.3 * 1 * 3m	Connector set: 2069250-1 (Tyco Electronics) Connector set: 2069250-1 (Tyco Electronics)

COMPLIANCE WITH THE MACHINERY DIRECTIVES

The MR-J3-D05 complies with the safety components laid down in the directive 2006/42/EC (Machinery).

Warranty

1. Warranty period and coverage  
We will repair any failure or defect hereinafter referred to as "failure" in our FA equipment hereinafter referred to as the "Product" arisen during warranty period at no charge due to causes for which we are responsible through the distributor from which you purchased the Product or our service provider. However, we will charge the actual cost of dispatching our engineer for an on-site repair work on request by customer in Japan or overseas countries. We are not responsible for any on-site readjustment and/or trial run that may be required after a defective unit are repaired or replaced.

[Term]  
The term of warranty for Product is twelve (12) months after your purchase or delivery of the Product to a place designated by you or eighteen (18) months from the date of manufacture whichever comes first ("Warranty Period"). Warranty period for repaired Product cannot exceed beyond the original warranty period before any repair work.

[Limitations]  
(1) You are requested to conduct an initial failure diagnosis by yourself, as a general rule. It can also be carried out by us or our service company upon your request and the actual cost will be charged. However, it will not be charged if we are responsible for the cause of the failure.

- This limited warranty applies only when the condition, method, environment, etc. of use are in compliance with the terms and conditions and instructions that are set forth in the instruction manual and user manual for the Product and the caution label affixed to the Product.
- Even during the term of warranty, the repair cost will be charged on you in the following cases:
  - a failure caused by your improper storing or handling, carelessness or negligence, etc., and a failure caused by your hardware or software problem
  - a failure caused by any alteration, etc. to the Product made on your side without our approval
  - a failure which may be regarded as avoidable, if your equipment in which the Product is incorporated is equipped with a safety device required by applicable laws and has any function or structure considered to be indispensable according to a common sense in the industry
  - a failure which may be regarded as avoidable if consumable parts designated in the instruction manual, etc. are duly maintained and replaced
  - any replacement of consumable parts (battery, fan, smoothing capacitor, etc.)
  - a failure caused by external factors such as inevitable accidents, including without limitation fire and abnormal fluctuation of voltage, and acts of God, including without limitation earthquake, lightning and natural disasters
  - a failure generated by an unforeseeable cause with a scientific technology that was not available at the time of the shipment of the Product from our company
  - any other failures which we are not responsible for or which you acknowledge we are not responsible for

- Term of warranty after the stop of production  
(1) We may accept the repair at charge for another seven (7) years after the production of the product is discontinued. The announcement of the stop of production for each model can be seen in our Sales and Service, etc.  
(2) Please note that the Product (including its spare parts) cannot be ordered after its stop of production.

3. Service in overseas countries  
Our regional FA Center in overseas countries will accept the repair work of the Product. However, the terms and conditions of the repair work may differ depending on each FA Center. Please ask your local FA center for details.

4. Exclusion of responsibility for compensation against loss of opportunity, secondary loss, etc.  
Whether under or after the term of warranty, we assume no responsibility for any damages arisen from causes for which we are not responsible, any losses of opportunity and/or profit incurred by you due to a failure of the Product, any damages, secondary damages or compensation for accidents arisen under a specific circumstance that are foreseen or unforeseen by our company, any damages to products other than the Product, and also compensation for any replacement work, readjustment, start-up test run of local machines and the Product and any other operations conducted by you.

5. Change of Product specifications  
Specifications listed in our catalogs, manuals or technical documents may be changed without notice.

6. Application and use of the Product  
(1) For the use of our General-Purpose AC Servo, its applications should be those that may not result in a serious damage even if any failure or malfunction occurs in General-Purpose AC Servo, and a backup or fail-safe function should operate on an external system to General-Purpose AC Servo when any failure or malfunction occurs.

(2) Our General-Purpose AC Servo is designed and manufactured as a general purpose product for use at general industries. Therefore, applications substantially influential on the public interest for such as atomic power plants and other power plants of electric power companies, and also which require a special quality assurance system, including applications for railway companies and government or public offices are not recommended, and we assume no responsibility for any failure caused by these applications when used. In addition, applications which may be substantially influential to human lives or properties for such as airlines, medical treatments, railway service, incineration and fuel systems, man-operated material handling equipment, entertainment machines, safety machines, etc. are not recommended, and we assume no responsibility for any failure caused by these applications when used. We will review the acceptability of the aforementioned applications, if you agree not to require a specific quality for a specific application. Please contact us for consultation.