



General-Purpose AC Servo

MITSUBISHI SERVO AMPLIFIERS & MOTORS
MELSERV/o-J4

SSCNET III/H Interface Drive Unit Instruction Manual



-MR-J4-DU_B4-RJ100

SAFETY INSTRUCTIONS

(Please read the instructions carefully before using the equipment.)

To use the equipment correctly, do not attempt to install, operate, maintain, or inspect the equipment until you have read through this Instruction Manual, Installation guide, and appended documents carefully. Do not use the equipment until you have a full knowledge of the equipment, safety information and instructions.





In this Instruction Manual, the safety instruction levels are classified into "WARNING" and "CAUTION".

 WARNING	Indicates that incorrect handling may cause hazardous conditions, resulting in death or severe injury.
 CAUTION	Indicates that incorrect handling may cause hazardous conditions, resulting in minor or moderate injury or property damage.

Note that the CAUTION level may lead to a serious consequence depending on conditions.

Please follow the instructions of both levels because they are important to personnel safety.

What must not be done and what must be done are indicated by the following diagrammatic symbols.

	Indicates what must not be done. For example, "No Fire" is indicated by  .
	Indicates what must be done. For example, grounding is indicated by  .

In this Instruction Manual, instructions at a lower level than the above, instructions for other functions, and so on are classified into "POINT".

After reading this Instruction Manual, keep it accessible to the operator.

[To prevent electric shock, note the following]

WARNING

- Before wiring, turn off the power and wait for 20 minutes or more until the charge lamp turns off. Then, confirm that the voltage between L+ and L- is safe with a voltage tester or others. Otherwise, an electric shock may occur. In addition, when confirming whether the charge lamp is off or not, always confirm it from the front of the converter unit.
 - Ground the converter unit, drive unit, and servo motor securely.
 - Any person who is involved in wiring and inspection should be fully competent to do the work.
 - Do not attempt to wire the converter unit, drive unit, and servo motor until they have been installed. Otherwise, it may cause an electric shock.
 - Do not operate the switches with wet hands. Otherwise, it may cause an electric shock.
 - The cables should not be damaged, stressed, loaded, or pinched. Otherwise, it may cause an electric shock.
 - During power-on or operation, do not open the front cover of the converter unit and the drive unit. Otherwise, it may cause an electric shock.
 - Do not operate the converter unit and the drive unit with the front cover removed. High-voltage terminals and charging area are exposed and you may get an electric shock.
 - Except for wiring or periodic inspection, do not remove the front cover of the converter unit and the drive unit even if the power is off. The converter unit and the drive unit are charged, and you may get an electric shock.
 - To prevent an electric shock, be sure to connect the protective earth (PE) terminal (marked \oplus) of the converter unit and the drive unit to the protective earth (PE) of the cabinet.
 - To avoid an electric shock, insulate the connections of the power supply terminals.
-

[To prevent fire, note the following]

CAUTION

- Install the converter unit, the drive unit, the servo motor, and the regenerative resistor on incombustible material. Installing them directly or close to combustibles will lead to smoke or a fire.
 - Be sure to connect a magnetic contactor between the power supply and the main circuit power supply (L1/L2/L3) of the converter unit, in order to configure a circuit that shuts off the power supply by the magnetic contactor. If the magnetic contactor is not connected, a continuous flow of a large current may cause smoke or a fire when the converter unit or the drive unit malfunctions.
 - Be sure to connect a magnetic contactor for each converter unit between the power supply and the power supply (L1/L2/L3) of the converter unit, in order to configure a circuit that shuts off the power supply by the magnetic contactor. If a molded-case circuit breaker or fuse is not connected, a continuous flow of a large current may cause smoke or a fire when the converter unit malfunctions.
 - When using the regenerative resistor, shut the power off with an alarm signal. Otherwise, a regenerative transistor malfunction or the like may overheat the regenerative resistor, causing smoke or a fire.
 - Provide adequate protection to prevent screws and other conductive matter, oil and other combustible matter from entering the converter unit, the drive unit, and the servo motor.
-

[To prevent injury, note the following]

 **CAUTION**

- Only the power/signal specified in the Instruction Manual should be applied to each terminal. Otherwise, it may cause an electric shock, fire, injury, etc.
 - Connect cables to the correct terminals. Otherwise, a burst, damage, etc., may occur.
 - Ensure that polarity (+/-) is correct. Otherwise, a burst, damage, etc., may occur.
 - The heat sink of the converter unit and drive unit, the regenerative resistor, the servo motor, etc. may be hot while power is on and for some time after power-off. Take safety measures such as providing covers to avoid accidentally touching them by hands and parts such as cables.
-

[Additional instructions]

The following instructions should also be fully noted. Incorrect handling may cause a malfunction, injury, electric shock, fire, etc.

[Transportation and installation]

CAUTION

- Transport the products correctly according to their mass.
- Use the eyebolts of the converter unit and of the drive unit only for transporting. Do not use the eyebolts for transporting with the converter unit and the drive unit mounted on a machine.
- Do not overtighten the eyebolts of the converter unit and of the drive unit. Tightening too hard may damage the tap.
- Stacking in excess of the specified number of product packages is not allowed.
- Do not hold the front cover, cables, or connectors when carrying the converter unit and drive unit. Otherwise, it may drop.
- Install the converter unit, the drive unit, and the servo motor in a load-bearing place in accordance with the Instruction Manual.
- Do not get on or put heavy load on the equipment. Otherwise, it may cause injury.
- The equipment must be installed in the specified direction.
- Maintain specified clearances between the converter unit/drive unit and the inner surfaces of a control cabinet or other equipment.
- Do not install or operate the converter unit, the drive unit, and the servo motor which have been damaged or have any parts missing.
- Do not block the intake and exhaust areas of the converter unit and the drive unit. Otherwise, it may cause a malfunction.
- Do not drop or apply heavy impact on the converter units, the drive units, and the servo motors. Otherwise, it may cause injury, malfunction, etc.
- Do not strike the connector. Otherwise, it may cause a connection failure, malfunction, etc.
- When you keep or use the equipment, please fulfill the following environment.

Item		Environment
Ambient temperature	Operation	0 °C to 55 °C (non-freezing)
	Storage	-20 °C to 65 °C (non-freezing)
Ambient humidity	Operation	5 %RH to 90 %RH (non-condensing)
	Storage	
Ambience		Indoors (no direct sunlight), free from corrosive gas, flammable gas, oil mist, dust, and dirt
Altitude		2000 m or less above sea level (Contact your local sales office for the altitude for options.)
Vibration resistance		5.9 m/s ² , at 10 Hz to 55 Hz (X, Y, Z axes)

- When the equipment has been stored for an extended period of time, contact your local sales office.
- When handling the converter unit and the drive unit, be careful with the sharp edges of the converter unit and drive unit.
- The converter unit and the drive unit must be installed in a metal cabinet.
- When fumigants that contain halogen materials, such as fluorine, chlorine, bromine, and iodine, are used for disinfecting and protecting wooden packaging from insects, they cause a malfunction when entering our products. Please take necessary precautions to ensure that remaining materials from fumigant do not enter our products, or treat packaging with methods other than fumigation, such as heat treatment. Additionally, disinfect and protect wood from insects before packing the products.
- To prevent a fire or injury in case of an earthquake or other natural disasters, securely install, mount, and wire the servo motor in accordance with the Instruction Manual.

[Wiring]

CAUTION

- Wire the equipment correctly and securely. Otherwise, the servo motor may operate unexpectedly.
- Make sure to connect the cables and connectors by using the fixing screws and the locking mechanism. Otherwise, the cables and connectors may be disconnected during operation.
- Do not install a power capacitor, surge killer, or radio noise filter (optional FR-BIF(-H)) on the drive unit output side.
- To avoid a malfunction of the servo motor, connect the wires to the correct phase terminals (U/V/W) of the drive unit and the servo motor.
- Connect the drive unit power outputs (U/V/W) to the servo motor power inputs (U/V/W) directly. Do not connect a magnetic contactor and others between them. Otherwise, it may cause a malfunction.

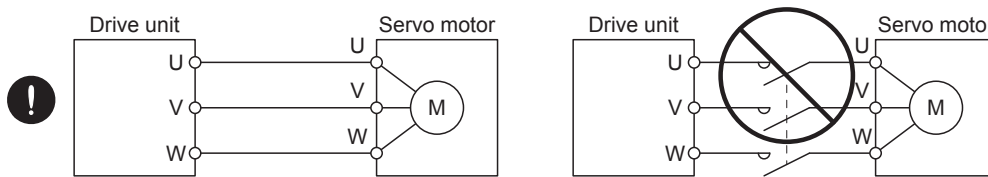

- The connection diagrams in this Instruction Manual are shown for sink interfaces, unless stated otherwise.
- Install the surge absorbing diode to the DC relay for control output signals in the converter unit and the drive unit in the specified direction. Otherwise, the converter unit and the drive unit will malfunction and will not output signals, disabling the emergency stop and other protective circuits.

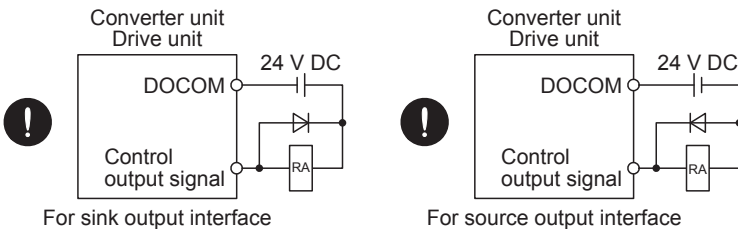

- When the wires are not tightened enough to the terminal block, the wires or terminal block may generate heat because of the poor contact. Be sure to tighten the wires with specified torque.
- Connecting a servo motor of the wrong axis to U, V, W, or CN2 of the drive unit may cause a malfunction.
- To prevent an unexpected restart of the drive unit, configure a circuit to turn off EM2 or EM1 when the main circuit power is turned off.
- To prevent malfunction, avoid bundling the power lines (input/output) of the converter unit and the signal cables together or running them in parallel to each other. Separate the power lines from the signal cables.

[Test run and adjustment]

CAUTION

- When executing a test run, follow the notice and procedures in this instruction manual. Otherwise, it may cause a malfunction, damage to the machine, or injury.
 - Before operation, check and adjust the parameter settings. Improper settings may cause some machines to operate unexpectedly.
 - Never make a drastic adjustment or change to the parameter values as doing so will make the operation unstable.
 - Do not get close to moving parts during the servo-on status.
-

[Usage]

CAUTION

- For equipment in which the moving part of the machine may collide against the load side, install a limit switch or stopper to the end of the moving part. The machine may be damaged due to a collision.
 - Do not disassemble, repair, or modify the product. Otherwise, it may cause an electric shock, fire, injury, etc. Disassembled, repaired, and/or modified products are not covered under warranty.
 - Before resetting an alarm, make sure that the run signal of the drive unit is off to prevent a sudden restart. Otherwise, it may cause an accident.
 - Use a noise filter, etc., to minimize the influence of electromagnetic interference. Electromagnetic interference may affect the electronic equipment used near the converter unit and the drive unit.
 - Do not burn or destroy the converter unit and the drive unit. Doing so may generate a toxic gas.
 - Use the converter unit and the drive unit with the specified servo motor.
 - Correctly wire options and peripheral equipment, etc. in the correct combination. Otherwise, it may cause an electric shock, fire, injury, etc.
 - The electromagnetic brake on the servo motor is designed to hold the motor shaft and should not be used for ordinary braking.
 - For such reasons as incorrect wiring, service life, and mechanical structure (e.g. where a ball screw and the servo motor are coupled via a timing belt), the electromagnetic brake may not hold the motor shaft. To ensure safety, install a stopper on the machine side.
 - If the dynamic brake is activated at power-off, alarm occurrence, etc., do not rotate the servo motor by an external force. Otherwise, it may cause a fire.
-

[Corrective actions]

CAUTION

- Ensure safety by confirming the power off, etc. before performing corrective actions. Otherwise, it may cause an accident.
- If it is assumed that a power failure, machine stoppage, or product malfunction may result in a hazardous situation, use a servo motor with an electromagnetic brake or provide an external brake system for holding purpose to prevent such hazard.
- Configure an electromagnetic brake circuit which is interlocked with an external emergency stop switch.

Contacts must be opened when ALM (Malfunction) or MBR (Electromagnetic brake interlock) turns off.

Contacts must be opened with the emergency stop switch.

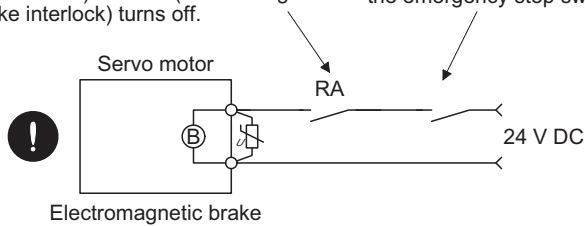

- When an alarm occurs, eliminate its cause, ensure safety, and deactivate the alarm to restart operation.
- If the molded-case circuit breaker or fuse is activated, be sure to remove the cause and secure safety before switching the power on. If necessary, replace the converter unit and drive unit, and recheck the wiring. Otherwise, it may cause smoke, fire, or an electric shock.
- Provide an adequate protection to prevent unexpected restart after an instantaneous power failure.
- To prevent an electric shock, injury, or fire from occurring after an earthquake or other natural disasters, ensure safety by checking conditions, such as the installation, mounting, wiring, and equipment before switching the power on.

[Maintenance, inspection and parts replacement]

CAUTION

- Make sure that the emergency stop circuit operates properly such that an operation can be stopped immediately and a power is shut off by the emergency stop switch.
- It is recommended that the converter unit and the drive unit be replaced every 10 years when it is used in general environment.
- When using a converter unit or a drive unit whose power has not been turned on for a long time, contact your local sales office.

[General instruction]

- To illustrate details, the equipment in the diagrams of this Instruction Manual may have been drawn without covers and safety guards. When the equipment is operated, the covers and safety guards must be installed as specified. Operation must be performed in accordance with this Instruction Manual.

DISPOSAL OF WASTE

- Please dispose a servo amplifier, battery (primary battery) and other options according to your local laws and regulations.

EEP-ROM LIFE

The number of write times to the EEPROM, which stores parameter settings, etc., is limited to 100,000. If the total number of the following operations exceeds 100,000, the converter unit and the drive unit may malfunction when the EEPROM reaches the end of its useful life.

- Write to the EEPROM due to parameter setting changes
- Write to the EEPROM due to device changes

STO FUNCTION OF THE DRIVE UNIT

When using the STO function of the drive unit, refer to chapter 13 of "MR-J4-_A_(-RJ) Servo Amplifier Instruction Manual". For the MR-J3-D05 safety logic unit, refer to app. 5 of "MR-J4-_B_(-RJ) Servo Amplifier Instruction Manual".

COMPLIANCE WITH GLOBAL STANDARDS

For compliance with global standards, refer to "MR-CV_/MR-CR55K_/MR-J4-DU_(-RJ) Instruction Manual".

ABOUT THE MANUALS

You must have this Instruction Manual and the following manuals to use this servo. Be sure to prepare all the instruction manuals necessary to use the servo safely.

Relevant manuals

Manual name	Manual No.
MELSERVO MR-J4-_B(-RJ) Servo Amplifier Instruction Manual	SH(NA)030098
MELSERVO MR-CV_/MR-CR55K_/MR-J4-DU_(-RJ) Instruction Manual	SH(NA)030145
MELSERVO-J4 Servo amplifier Instruction Manual (Troubleshooting)	SH(NA)030108
MELSERVO MR-D30 Instruction Manual ^{*1}	SH(NA)030131
MELSERVO Servo Motor Instruction Manual (Vol. 3)	SH(NA)030099
EMC Installation Guidelines	IB(NA)67310

*1 It is necessary for using an MR-D30 functional safety unit.

This Instruction Manual does not describe the following items. Refer to the section of the detailed explanation field for details. "MR-J4-_B_" means "MR-J4-_B_(-RJ) Servo Amplifier Instruction Manual". "MR-J4-DU_B_" means "MR-CV_/MR-CR55K_/MR-J4-DU_(-RJ) Instruction Manual".

Item	Detailed explanation
Normal gain adjustment ^{*1}	MR-J4-_B_ chapter 6
Special adjustment functions ^{*2}	MR-J4-_B_ chapter 7
Dimensions	MR-J4-DU_B_ chapter 7
Absolute position detection system ^{*3}	MR-J4-_B_ chapter 12

*1 For parallel drive systems, the one-touch tuning is unavailable.

*2 A combination of the MR-CV55K4_ power regeneration converter unit and drive unit does not comply with SEMI-F47 standard. For the advanced vibration suppression control II and the adaptive filter II, "Automatic setting" is invalid. Only "Manual setting" is valid.

*3 For absolute position detection systems, connect an optional battery to only the drive unit of the encoder master servo amplifier. Do not connect the optional battery to the drive units of the encoder slave servo amplifiers.

CABLES USED FOR WIRING

Wires mentioned in this Instruction Manual are selected based on the ambient temperature of 40 °C.

U.S. CUSTOMARY UNITS

U.S. customary units are not shown in this manual. Convert the values if necessary according to the following table.

Quantity	SI (metric) unit	U.S. customary unit
Mass	1 [kg]	2.2046 [lb]
Length	1 [mm]	0.03937 [inch]
Torque	1 [N.m]	141.6 [oz.inch]
Moment of inertia	1 [($\times 10^{-4}$ kg.m ²)]	5.4675 [oz.inch ²]
Load (thrust load/axial load)	1 [N]	0.2248 [lbf]
Temperature	N [°C] $\times 9/5 + 32$	N [°F]

CONTENTS

SAFETY INSTRUCTIONS	1
DISPOSAL OF WASTE	8
EEP-ROM LIFE	8
STO FUNCTION OF THE DRIVE UNIT	8
COMPLIANCE WITH GLOBAL STANDARDS	8
ABOUT THE MANUALS	9
CABLES USED FOR WIRING	9
U.S. CUSTOMARY UNITS	9
CHAPTER 1 FUNCTIONS AND CONFIGURATION	12
1.1 Description	12
1.2 Model designation	13
1.3 Combinations of power regeneration converter units, drive units, and servo motors	13
1.4 Compatible controller	14
1.5 Function list	14
1.6 Configuration including peripheral equipment	15
CHAPTER 2 INSTALLATION	16
2.1 Installation direction and clearances	17
CHAPTER 3 SIGNALS AND WIRING	20
3.1 Connection example of power circuit	21
3.2 Alarm occurrence timing chart	26
When you use the forced stop deceleration function	27
When you do not use the forced stop deceleration function	30
3.3 Grounding	31
CHAPTER 4 STARTUP	32
4.1 Switching power on for the first time	33
4.2 Startup	34
CHAPTER 5 PARAMETERS	35
CHAPTER 6 TROUBLESHOOTING	41
6.1 Troubleshooting for MR-CV_ power regeneration converter unit	41
Explanation for the lists	41
Alarm list	42
Warning list	42
6.2 Troubleshooting for drive unit	43
Explanation for the lists	43
Alarm list	44
Warning list	53
CHAPTER 7 CHARACTERISTICS	55
7.1 Overload protection characteristics	55
7.2 Power supply capacity and generated loss	56
7.3 Dynamic brake characteristics	58
7.4 Inrush currents at power-on of main circuit/control circuit	60

Inrush currents of the power regeneration converter.	60
Inrush current of the drive unit.	60
CHAPTER 8 OPTIONS AND PERIPHERAL EQUIPMENT	61
8.1 MR Configurator2	62
Restrictions	62
Using the parallel drive system	62
How to select the model name of the servo amplifier registered.	66
8.2 AC reactor	67
8.3 External dynamic brake	69
CHAPTER 9 USING STO FUNCTION	72
CHAPTER 10 APPLICATION OF FUNCTIONS	74
10.1 Compatible with MR-D30 functional safety unit	74
Description.	74
Connection diagram	76
CHAPTER 11 APPENDIX	78
11.1 Analog monitor	78
REVISIONS	80
WARRANTY	81
TRADEMARKS	82

1 FUNCTIONS AND CONFIGURATION

The following items are the same as those for MR-J4-_B_(-RJ). Refer to the section of the detailed explanation field for details. "MR-J4-DU_B_" means "MR-CV_/MR-CR55K_/MR-J4-DU_(-RJ) Instruction Manual".

Item	Detailed explanation
Function block diagram	MR-J4-DU_B_ section 3.1
Standard specifications	MR-J4-DU_B_ section 1.4
Structure *1	MR-J4-DU_B_ sections 3.2 and 5.1

*1 Do not connect an external encoder to the CN2L connector of the MR-J4-DU_B4-RJ100 drive unit.

1.1 Description

This Instruction Manual describes MR-J4-DU_B4-RJ100 drive units and MR-CV55K4_ power regeneration converter units compatible with parallel drive systems.

Parallel drive systems drive a servo motor with multiple MR-J4-DU_B4-RJ100 drive units and MR-CV55K4_ power regeneration converter units connected. The encoder cables are wired by the daisy chain method. Delivering the encoder information to all servo amplifiers, from encoder master servo amplifiers to encoder slave servo amplifiers, ensures reduced wiring. A encoder distribution unit is not required.

The following shows a system that drives a servo motor with four MR-J4-DU_B4-RJ100 drive units and four MR-CV55K4_ power regeneration converter units connected. For the number of drive units required to be connected to one servo motor, refer to the following.

☞ Page 13 Combinations of power regeneration converter units, drive units, and servo motors

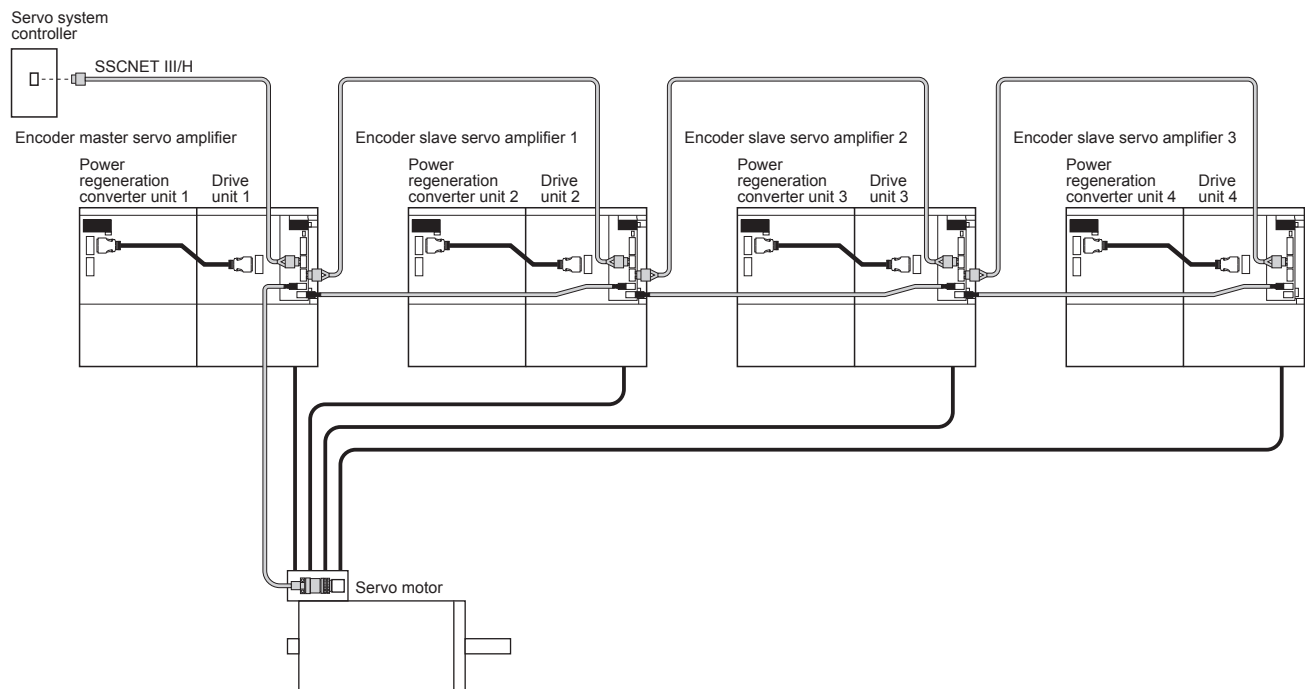

1.2 Model designation

Point

This section describes MR-J4-DU_B4-RJ100 drive units only. For MR-CV55K4_power regeneration converter units, refer to section 1.2 in "MR-CV_/MR-CR55K_/MR-J4-DU_(-RJ) Instruction Manual".

Rating plate

The following shows an example of the rating plate for explanation of each item.

 MITSUBISHI ELECTRIC AC SERVO SER. A7Z001001 MODEL MR-J4-DU55KB4-RJ100 POWER : 55kW INPUT : DC513-648V 113.7A OUTPUT : 3PH323V 0-360Hz 143.0A STD.: IEC/EN 61800-5-1 MAN.: IB(NA)0300228 Max. Surrounding Air Temp.: 55°C IP20 (Terminal block IP00) MSIP-REI-MEK-TC301A013G52 BC343U843 MITSUBISHI ELECTRIC CORPORATION DATE: 2017-12 TOKYO 100-8310, JAPAN MADE IN JAPAN (PASSED)	Serial number
	Model
	Capacity
	Applicable power supply
	Rated output current
	Standard, Manual number
	Ambient temperature
	IP rating
	KC certification number
	The year and month of manufacture
Country of origin	

Model

The following describes what each block of a model name indicates. Not all combinations of the symbols are available.

MR - J 4 - DU 5 5 KB 4 - RJ 1 0 0											
Series	Special specifications										
Indicates drive unit	<table border="1"> <thead> <tr> <th>Symbol</th> <th>Special specifications</th> </tr> </thead> <tbody> <tr> <td>-RJ100</td> <td>Compatible with parallel drive system</td> </tr> </tbody> </table>	Symbol	Special specifications	-RJ100	Compatible with parallel drive system						
Symbol	Special specifications										
-RJ100	Compatible with parallel drive system										
Rated output	Power supply										
<table border="1"> <thead> <tr> <th>Symbol</th> <th>Rated output [kW]</th> </tr> </thead> <tbody> <tr> <td>45K</td> <td>45</td> </tr> <tr> <td>55K</td> <td>55</td> </tr> </tbody> </table>	Symbol	Rated output [kW]	45K	45	55K	55	<table border="1"> <thead> <tr> <th>Symbol</th> <th>Power supply</th> </tr> </thead> <tbody> <tr> <td>4</td> <td>3-phase 380 V AC to 480 V AC</td> </tr> </tbody> </table>	Symbol	Power supply	4	3-phase 380 V AC to 480 V AC
Symbol	Rated output [kW]										
45K	45										
55K	55										
Symbol	Power supply										
4	3-phase 380 V AC to 480 V AC										
Interface											
<table border="1"> <thead> <tr> <th>Symbol</th> <th>Interface</th> </tr> </thead> <tbody> <tr> <td>B</td> <td>SSCNET III/H</td> </tr> </tbody> </table>	Symbol	Interface	B	SSCNET III/H							
Symbol	Interface										
B	SSCNET III/H										

1.3 Combinations of power regeneration converter units, drive units, and servo motors

Power regeneration converter unit	Drive unit	Rotary servo motor
Two units of MR-CV55K4	Two units of MR-J4-DU55KB4-RJ100	HG-JR110K24W0C
Four units of MR-CV55K4	Four units of MR-J4-DU45KB4-RJ100	HG-JR150K24W0C HG-JR180K24W0C
Four units of MR-CV55K4	Four units of MR-J4-DU55KB4-RJ100	HG-JR200K24W0C HG-JR220K24W0C

1.4 Compatible controller

Motion controller	Operating system	Remark
Q173DSCPU	SW8DNC-SV22S87QJ	Special operating system *1
Q172DSCPU	SW8DNC-SV22S87QL	Special operating system *1

*1 Motion controllers with a special operating system can be used. Motion controllers with a standard operating system cannot drive ultrahigh capacity servo motors. For details, contact your local sales office.

1.5 Function list

For the drive unit functions not mentioned in this section, refer to section 1.5 in "MR-J4-_B_(-RJ) Servo Amplifier Instruction Manual".

Function	Description	Detailed explanation
Advanced vibration suppression control II	For parallel drive systems, "Automatic setting" is invalid. Only "Manual setting" is valid. This function suppresses vibration and residual vibration at an arm end.	☞ Page 35 PARAMETERS
Adaptive filter II	For parallel drive systems, "Automatic setting" is invalid. Only "Manual setting" is valid. The servo amplifier detects mechanical resonance and sets filter characteristics automatically to suppress mechanical vibration.	☞ Page 35 PARAMETERS
Scale measurement function	For parallel drive systems, the scale measurement function is unavailable.	—
J3 compatibility mode	For parallel drive systems, the J3 compatibility mode is unavailable.	—
Machine analyzer function	For parallel drive systems, the machine analyzer function is unavailable.	—
Test operation mode	For parallel drive systems, the test operation mode is unavailable.	—
Linear servo system	For parallel drive systems, the linear servo system is unavailable.	—
Direct drive servo system	For parallel drive systems, the direct drive servo system is unavailable.	—
Fully closed loop system	For parallel drive systems, the fully closed loop system is unavailable.	—
One-touch tuning	For parallel drive systems, the one-touch tuning is unavailable.	—
SEMI-F47 function	A combination of the MR-CV55K4_ power regeneration converter unit and drive unit does not comply with SEMI-F47 standard.	☞ Page 35 PARAMETERS
Tough drive function	The tough drive function includes two types: the vibration tough drive and the instantaneous power failure tough drive. For parallel drive systems, only the vibration tough drive is available. This function makes the equipment continue operating even under the condition that an alarm occurs.	☞ Page 35 PARAMETERS
STO function	This function is a functional safety that complies with IEC/EN 61800-5-2. You can create a safety system for the equipment easily.	☞ Page 72 USING STO FUNCTION
Power monitoring function	When checking the power in the parallel drive system, use the servo system controller. This function calculates the power running energy and the regenerative power from the data in the servo amplifier such as speed and current. In the SSCNET III/H system, the data are sent to a servo system controller for analyzing and displaying the power consumption on a display.	—
MR-D30 functional safety unit	By using MR-D30 together, the safety observation function can be expanded. STO, SS1, SS2, SOS, SLS, SSM, and SBC can be used.	☞ Page 74 APPLICATION OF FUNCTIONS
MR-J3-D05 safety logic unit	For parallel drive systems, the MR-J3-D05 safety logic unit is unavailable.	—
MR-CR_ resistance regeneration converter unit	For parallel drive systems, the MR-CR_ resistance regeneration converter unit is unavailable.	—

1.6 Configuration including peripheral equipment

The diagram shows a system that drives a servo motor with four MR-J4-DU_B4-RJ100 drive units and four MR-CV55K4_ power regeneration converter units connected.

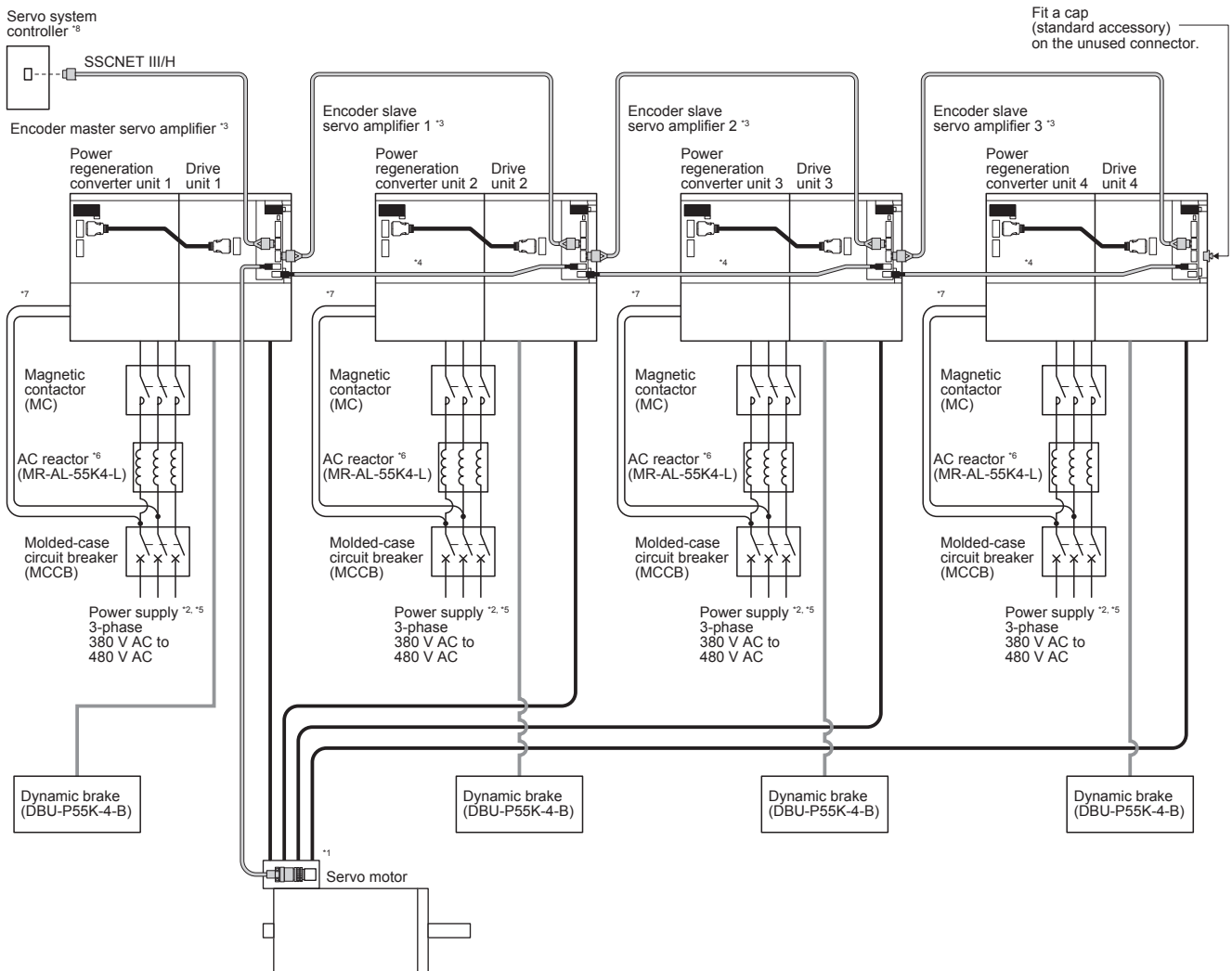

- *1 Connect the grounding wire of the servo motor to only the first drive unit. If the grounding wire of the servo motor is connected to two or more drive units, the circulating current may pass through the grounding wire depending on wiring conditions. When connecting grounding wires to two or more drive units, be sure to twist the wires of the drive unit power outputs (U/V/W) for safety reasons.
- *2 For the power supply, one molded-case circuit breaker, one AC reactor (MR-AL-55K4-L), and one magnetic contactor are required for each power regeneration converter unit.
- *3 Since the system is connected via SSCNET III/H, use a servo amplifier near the Motion controller as an encoder master servo amplifier, and use the remaining servo amplifiers as encoder slave servo amplifiers. Connect the encoder master servo amplifier and slave servo amplifiers in series to the same SSCNET III/H system.
- *4 The encoder cables between drive units should be within 5 m.
- *5 Supply power to all the servo amplifiers (power regeneration converter units and drive units) from the same power source. If power is supplied from different power sources, a difference may be generated between outputs of the encoder master servo amplifier and encoder slave servo amplifiers. This may cause the servo motor to operate unpredictably.
- *6 Even if an AC reactor is installed on the power regeneration converter unit, the functions operate normally.
- *7 Switch on the control circuit power supplies of all the servo amplifiers (power regeneration converter units and drive units) simultaneously.
- *8 Stop all the drive units with the emergency stop of the controller if an alarm occurs.

2 INSTALLATION

WARNING

- To prevent electric shock, ground each equipment securely.

CAUTION

- Stacking in excess of the specified number of product packages is not allowed.
- Do not hold the front cover, cables, or connectors when carrying the converter unit and drive unit. Otherwise, it may drop.
- Install the equipment on incombustible material. Installing them directly or close to combustibles will lead to a fire.
- Install the converter unit, the drive unit, and the servo motor in a load-bearing place in accordance with the Instruction Manual.
- Do not get on or put heavy load on the equipment. Otherwise, it may cause injury.
- Use the equipment within the specified environment. For the environment, refer to section 1.4 in "MR-CV_/MR-CR55K_/MR-J4-DU_(-RJ) Instruction Manual".
- Provide adequate protection to prevent screws and other conductive matter, oil and other combustible matter from entering the converter unit and the drive unit.
- Do not block the intake and exhaust areas of the converter unit and the drive unit. Otherwise, it may cause a malfunction.
- Do not drop or apply heavy impact on the converter units, the drive units, and the servo motors. Otherwise, it may cause injury, malfunction, etc.
- Do not install or operate the converter unit and the drive unit which have been damaged or have any parts missing.
- When the equipment has been stored for an extended period of time, contact your local sales office.
- When handling the converter unit and the drive unit, be careful with the sharp edges of the converter unit and drive unit.
- The converter unit and the drive unit must be installed in a metal cabinet.
- When fumigants that contain halogen materials, such as fluorine, chlorine, bromine, and iodine, are used for disinfecting and protecting wooden packaging from insects, they cause a malfunction when entering our products. Please take necessary precautions to ensure that remaining materials from fumigant do not enter our products, or treat packaging with methods other than fumigation, such as heat treatment. Additionally, disinfect and protect wood from insects before packing the products.

The following items are the same as those for MR-J4-_B_(-RJ). Refer to the section of the detailed explanation field for details. "MR-J4-_B_" means "MR-J4-_B_(-RJ) Servo Amplifier Instruction Manual". "MR-J4-DU_B_" means "MR-CV_/MR-CR55K_/MR-J4-DU_(-RJ) Instruction Manual".

Item	Detailed explanation
Keeping out of foreign materials	MR-J4-DU_B_ section 2.2
Encoder cable stress	MR-J4-_B_ section 2.3
SSCNET III cable laying	MR-J4-_B_ section 2.4
Inspection items	MR-J4-DU_B_ section 2.3
Parts having service life	MR-J4-DU_B_ section 2.4
Restrictions when using this product at altitude exceeding 1000 m and up to 2000 m above sea level	MR-J4-DU_B_ section 2.5

2.1 Installation direction and clearances

⚠ CAUTION

- The equipment must be installed in the specified direction. Otherwise, it may cause a malfunction.
- Maintain specified clearances between the converter unit/drive unit and the inner surfaces of a control cabinet or other equipment. Otherwise, it may cause a malfunction.

Installation

Make sure to connect a drive unit to the right side of a power regeneration converter unit. Since the units require a cooling mechanism outside the cabinet, an opening must be provided in each mounting surface as shown below.

The TE2-1 terminal block of the drive unit and the TE2 terminal block of the power regeneration converter unit are connected using a bus bar. Thus, remove the supplied cover on the right side of the power regeneration converter unit.

■ Clearance between sets of combined power regeneration converter units and drive units mounted side by side

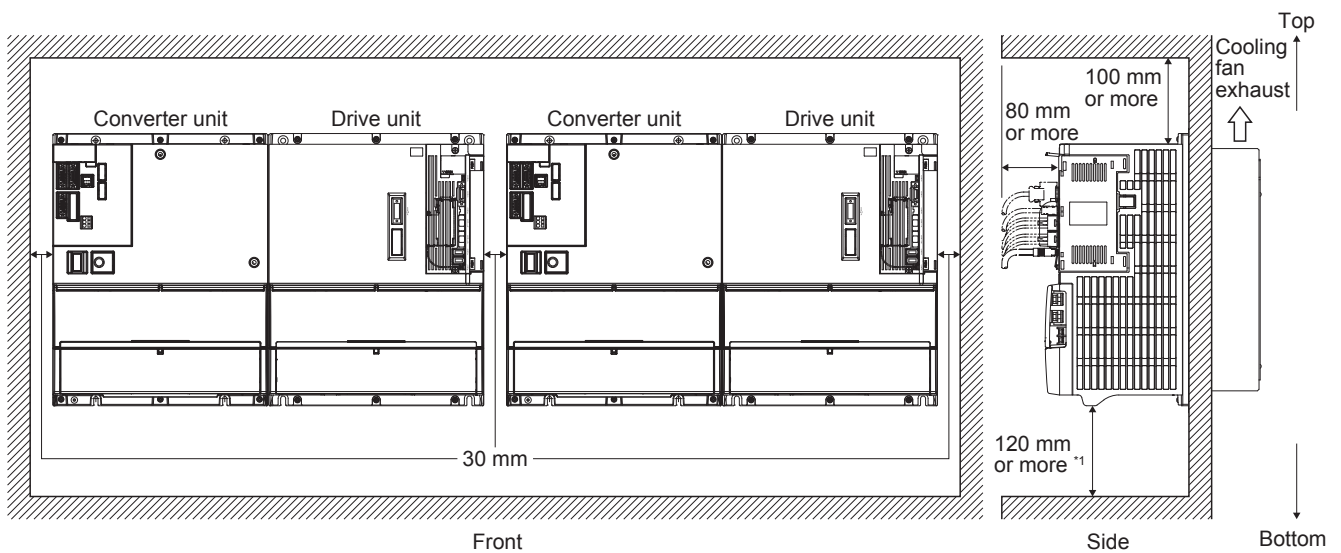

*1 A clearance of at least 120 mm is required. Leave a clearance, taking into consideration the flexibility of the cable.

■ Clearance between sets of combined power regeneration converter units and drive units mounted above each other

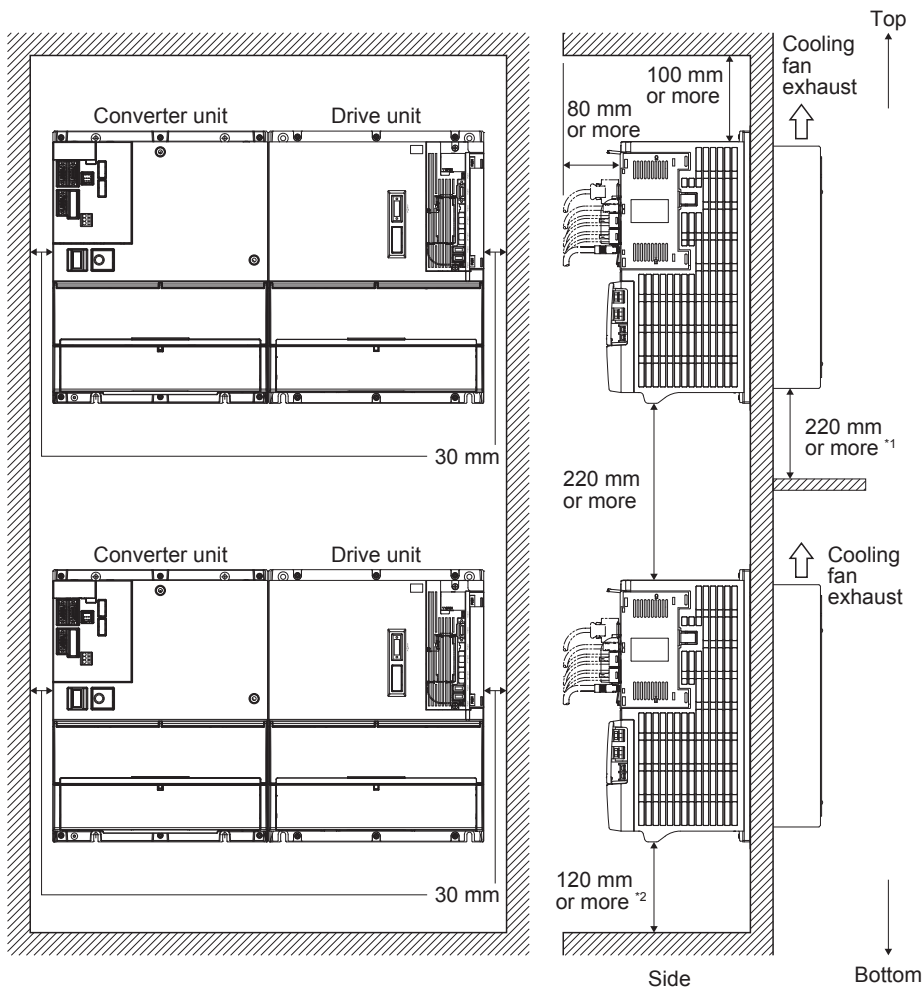

*1 Take measures, such as installing a shield, to prevent cooling fan exhaust of the lower unit from affecting the cooling fan on the upper unit.

*2 A clearance of at least 120 mm is required. Leave a clearance, taking into consideration the flexibility of the cable.

Mounting hole process drawing

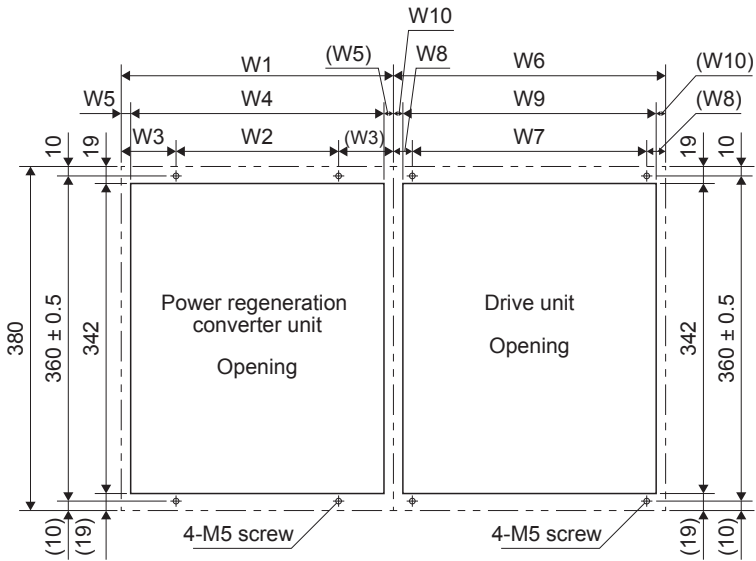

Unit		Variable dimensions [mm]									
		W1	W2	W3	W4	W5	W6	W7	W8	W9	W10
Power regeneration converter unit	MR-CV55K4	300	180 ± 0.5	60	282	9	—	—	—	—	—
Drive unit	MR-J4-DU45KB4-RJ100 MR-J4-DU55KB4-RJ100	—	—	—	—	—	300	260 ± 0.5	20	281	9.5

3 SIGNALS AND WIRING

⚠ WARNING

- Any person who is involved in wiring should be fully competent to do the work.
- Before wiring, turn off the power and wait for 20 minutes or more until the charge lamp turns off. Then, confirm that the voltage between L+ and L- is safe with a voltage tester or others. Otherwise, an electric shock may occur. In addition, when confirming whether the charge lamp is off or not, always confirm it from the front of the converter unit.
- Ground the converter unit, drive unit, and servo motor securely.
- Do not attempt to wire the converter unit, drive unit, and servo motor until they have been installed. Otherwise, it may cause an electric shock.
- The cables should not be damaged, stressed, loaded, or pinched. Otherwise, it may cause an electric shock.
- To avoid an electric shock, insulate the connections of the power supply terminals.

⚠ CAUTION

- Wire the equipment correctly and securely. Otherwise, the servo motor may operate unexpectedly, resulting in injury.
- Connect cables to the correct terminals. Otherwise, a burst, damage, etc., may occur.
- Ensure that polarity (+/-) is correct. Otherwise, a burst, damage, etc., may occur.
- The surge absorbing diode installed to the DC relay for control output should be fitted in the specified direction. Otherwise, the converter unit and the drive unit will malfunction and will not output signals, disabling the emergency stop and other protective circuits.

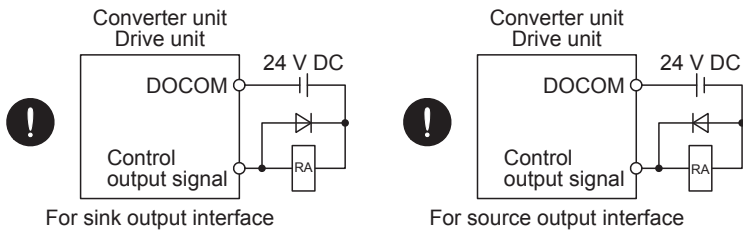

- Use a noise filter, etc., to minimize the influence of electromagnetic interference. Electromagnetic interference may affect the electronic equipment used near the converter unit and the drive unit.
- Do not install a power capacitor, surge killer, or radio noise filter (optional FR-BIF(-H)) with the power line of the servo motor.
- Do not modify the equipment.
- Connect the drive unit power outputs (U/V/W) to the servo motor power inputs (U/V/W) directly. Do not connect a magnetic contactor and others between them. Otherwise, it may cause a malfunction.

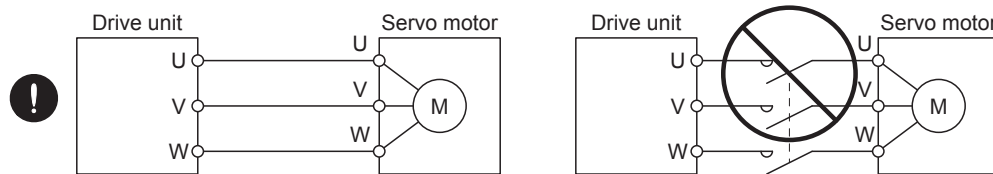

- Connecting a servo motor of the wrong axis to U, V, W, or CN2 of the drive unit may cause a malfunction.
- Before wiring, switch operation, etc., eliminate static electricity. Otherwise, it may cause a malfunction.

The following items are the same as those for MR-J4-_B_(-RJ). Refer to the section of the detailed explanation field for details. "MR-J4-_B_" means "MR-J4-_B_(-RJ) Servo Amplifier Instruction Manual". "MR-J4-DU_B_" means "MR-CV_/MR-CR55K_/MR-J4-DU_(-RJ) Instruction Manual".

Item	Detailed explanation
I/O signal connection example	MR-J4-_B_ section 3.2
Explanation of power supply system	MR-J4-DU_B_ sections 3.3 and 5.2
Connectors and pin assignment	MR-J4-DU_B_ sections 3.3 and 5.2
Signal (device) explanations	MR-J4-_B_ section 3.5
Forced stop deceleration function	MR-J4-_B_ section 3.6
Interface	MR-J4-DU_B_ section 3.3
SSCNET III cable connection	MR-J4-_B_ section 3.9

3.1 Connection example of power circuit

WARNING

- Insulate the connections of the power supply terminals. Otherwise, an electric shock may occur.

CAUTION

- Be sure to connect a magnetic contactor between the power supply and the main circuit power supply (L1/L2/L3) of the power regeneration converter unit, in order to configure a circuit that shuts off the power supply by the power regeneration converter unit. If a magnetic contactor is not connected, continuous flow of a large current may cause a fire when the power regeneration converter unit or the drive unit malfunctions.
- Use ALM (Malfunction) to shut the power off. Not doing so may cause a fire when the power regeneration converter unit malfunctions and causes the AC reactor to overheat.
- The power regeneration converter unit has a built-in surge absorber (varistor) to reduce exogenous noise and to suppress lightning surge. Exogenous noise or lightning surge deteriorates the varistor characteristics, and the varistor may be damaged. To prevent a fire, use a molded-case circuit breaker or fuse for the input power supply.
- Check the power regeneration converter unit model, and then input proper voltage to the power regeneration converter unit power supply. If input voltage exceeds the upper limit, the power regeneration converter unit and the drive unit will break down.

Point

For drive units, EM2 has the same function as EM1 in the torque control mode.

Even if alarm has occurred, do not switch off the control circuit power supply. When the control circuit power supply is shut off, an optical module does not operate, and optical transmission of SSCNET III/H communication is interrupted. Therefore, the next servo amplifiers and drive units show "AA" on the display and shut off the base circuit, stopping the servo motor with the dynamic brake.

For the magnetic contactor control connector (CN23), refer to section 3.3 in "MR-CV_/MR-CR55K_/MR-J4-DU_(-RJ) Instruction Manual".

If the control axis No. is not be set correctly, or an SSCNET III cable is not be connected, the relay may switch on and off repeatedly. Check the control axis No. setting and SSCNET III cable connection.

Connection example of encoder master servo amplifier

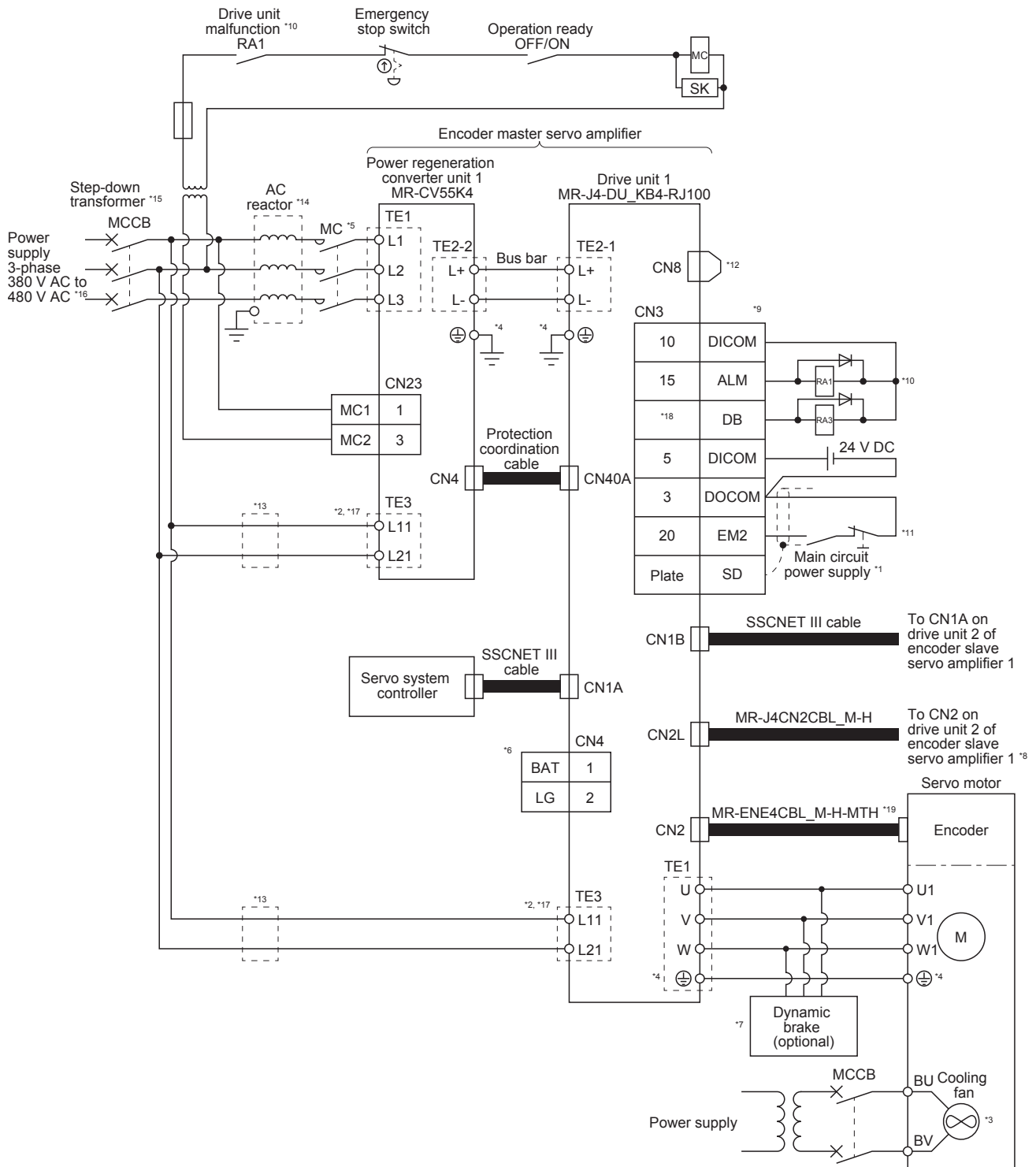

- *1 To prevent an unexpected restart of the drive unit, configure a circuit to turn off EM2 (Forced stop 2) in the drive unit when the main circuit power is turned off.
- *2 Always match the phases of the power supply connected to L11 and L21 on the power regeneration converter unit and the drive unit with the phases connected to L1 and L2. Otherwise, the drive unit and the power regeneration converter unit may malfunction.
- *3 Always supply power to the cooling fan terminal. For specifications of the cooling fan power supply and how to detect a failure, refer to "Servo Motor Instruction Manual (Vol. 3)".
- *4 Connect the grounding wire from the servo motor to the protective earth (PE) terminal of the drive unit. Put the grounding wires of the drive unit and the power regeneration converter unit together into one on the protective earth (PE) terminal of the cabinet, and then connect to the ground. Connect the grounding wire of the servo motor to only the drive unit of the encoder master servo amplifier. If the grounding wire of the servo motor is connected to two or more drive units, the circulating current may pass through the grounding wire depending on wiring conditions. When connecting grounding wires to two or more drive units, be sure to twist the wires of the drive unit power outputs (U/V/W).
- *5 Use a magnetic contactor with an operation delay time (interval between current being applied to the coil until closure of contacts) of 80 ms or less.
- *6 For absolute position detection systems, connect an optional battery to only the drive unit of the encoder master servo amplifier. Do not connect the optional battery to the drive units of the encoder slave servo amplifiers.
- *7 Use an external dynamic brake (option) together. Failure to do so will cause an accident, such as machine collision because the servo motor does not stop immediately but coasts at emergency stop. For wiring of the dynamic brake, refer to the following.
 Page 69 External dynamic brake
- *8 Encoder signals are distributed to all the drive units in the system via each drive unit.
- *9 This diagram shows sink I/O interface. For source I/O interface, refer to section 3.8.3 in MR-J4-_B_(-RJ) Servo Amplifier Instruction Manual.
- *10 Configure a sequence that will shut off the main circuit power when an alarm occurs.
- *11 Configure a circuit to simultaneously turn on or off EM2 (Forced stop 2) in the drive units of the encoder master servo amplifier and encoder slave servo amplifiers.
- *12 When not using the STO function, always attach the short-circuit connector supplied with the drive unit.
- *13 If the wire size used for the branch circuit is smaller than that used for L1, L2, and L3, install an overcurrent protection device (molded-case circuit breaker, fuse, or others) to protect the circuit.
- *14 Even if an AC reactor is installed on the power regeneration converter unit, the functions operate normally.
- *15 A step-down transformer is required when the coil voltage of the magnetic contactor is 200 V class.
- *16 Supply power to all the servo amplifiers (power regeneration converter units and drive units) from the same power source. If power is supplied from different power sources, a difference may be generated between outputs of the encoder master servo amplifier and that of encoder slave servo amplifiers. This may cause the servo motor to operate unpredictably.
- *17 Switch on the control circuit power supplies of all the servo amplifiers (power regeneration converter units and drive units) simultaneously.
- *18 The dynamic brake must be controlled by the drive unit of the encoder master servo amplifier. Assign DB (Dynamic brake interlock) in [Pr. PD07] to [Pr. PD09].
- *19 The encoder cable has a thermistor signal wire. Wiring the thermistor signal is unnecessary.

Connection example of encoder slave servo amplifier

This example is the connection for the encoder slave servo amplifier 1.

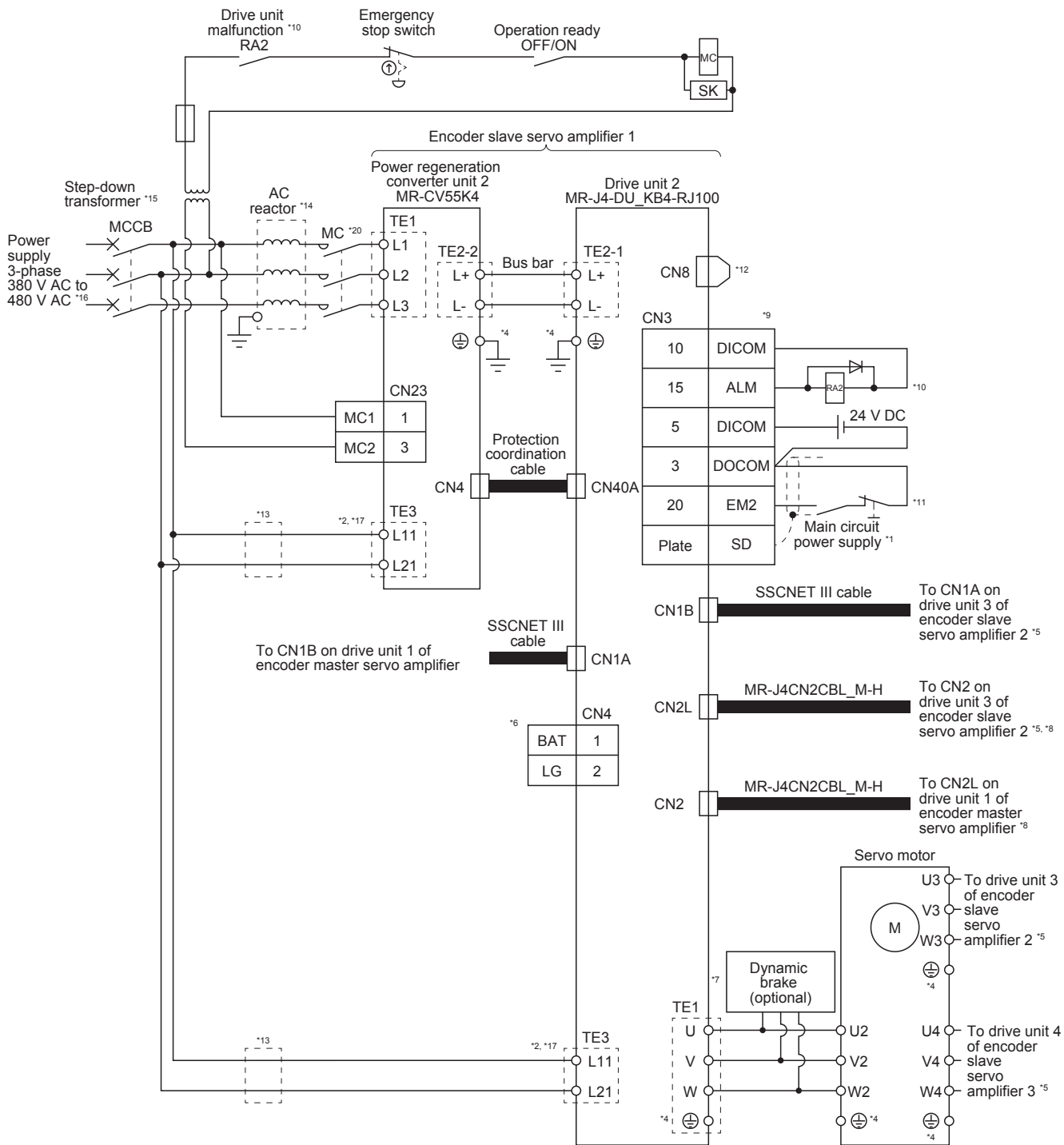

- *1 To prevent an unexpected restart of the drive unit, configure a circuit to turn off EM2 (Forced stop 2) in the drive unit when the main circuit power is turned off.
- *2 Always match the phases of the power supply connected to L11 and L21 on the power regeneration converter unit and the drive unit with the phases connected to L1 and L2. Otherwise, the drive unit and the power regeneration converter unit may malfunction.
- *3 Use a magnetic contactor with an operation delay time (interval between current being applied to the coil until closure of contacts) of 80 ms or less.
- *4 Connect the grounding wire from the servo motor to the protective earth (PE) terminal of the drive unit. Put the grounding wires of the drive unit and the power regeneration converter unit together into one on the protective earth (PE) terminal of the cabinet, and then connect to the ground. Connect the grounding wire of the servo motor to only the drive unit of the encoder master servo amplifier. If the grounding wire of the servo motor is connected to two or more drive units, the circulating current may pass through the grounding wire depending on wiring conditions. When connecting grounding wires to two or more drive units, be sure to twist the wires of the drive unit power outputs (U/V/W).
- *5 This is for connecting four drive units and four power regeneration converter units to the servo motor.
- *6 For the absolute position detection system, connect an optional battery to only the drive unit of the encoder master servo amplifier. Do not connect the optional battery to the drive units of the encoder slave servo amplifiers.
- *7 Use an external dynamic brake (option) together. Failure to do so will cause an accident, such as machine collision because the servo motor does not stop immediately but coasts at emergency stop. For wiring of the dynamic brake, refer to the following.
 Page 69 External dynamic brake
- *8 Encoder signals are distributed to all the drive units in the system via each drive unit.
- *9 This diagram shows sink I/O interface. For source I/O interface, refer to section 3.8.3 in MR-J4-_B_(-RJ) Servo Amplifier Instruction Manual.
- *10 Configure a sequence that will shut off the main circuit power when an alarm occurs.
- *11 Configure a circuit to simultaneously turn on or off EM2 (Forced stop 2) in the drive units of the encoder master servo amplifier and encoder slave servo amplifiers.
- *12 When not using the STO function, always attach the short-circuit connector supplied with the drive unit.
- *13 If the wire size used for the branch circuit is smaller than that used for L1, L2, and L3, install an overcurrent protection device (molded-case circuit breaker, fuse, or others) to protect the circuit.
- *14 Even if an AC reactor is installed on the power regeneration converter unit, the functions operate normally.
- *15 A step-down transformer is required when the coil voltage of the magnetic contactor is 200 V class.
- *16 Supply power to all the servo amplifiers (power regeneration converter units and drive units) from the same power source. If power is supplied from different power sources, a difference may be generated between outputs of the encoder master servo amplifier and that of encoder slave servo amplifiers. This may cause the servo motor to operate unpredictably.
- *17 Switch on the control circuit power supplies of all the servo amplifiers (power regeneration converter units and drive units) simultaneously.

3.2 Alarm occurrence timing chart

CAUTION

- When an alarm has occurred, remove its cause, make sure that the operation signal is not being inputted, ensure safety, and reset the alarm before restarting operation.

Point

When SSCNET III/H communication is shut off, the servo motor stops with the dynamic brake.

In the torque control mode, the forced stop deceleration function is unavailable.

This section describes MR-J4-DU_B4-RJ100 drive units only. For MR-CV55K4_power regeneration converter units, refer to section 3.3 in "MR-CV_/MR-CR55K_/MR-J4-DU_(-RJ) Instruction Manual".

To deactivate the alarm, cycle the control circuit power or give the error reset or CPU reset command from the servo system controller. However, the alarm cannot be deactivated unless its cause is removed.

Timing charts in this section show that an alarm occurs in any axis in the four axis of the parallel drive system.

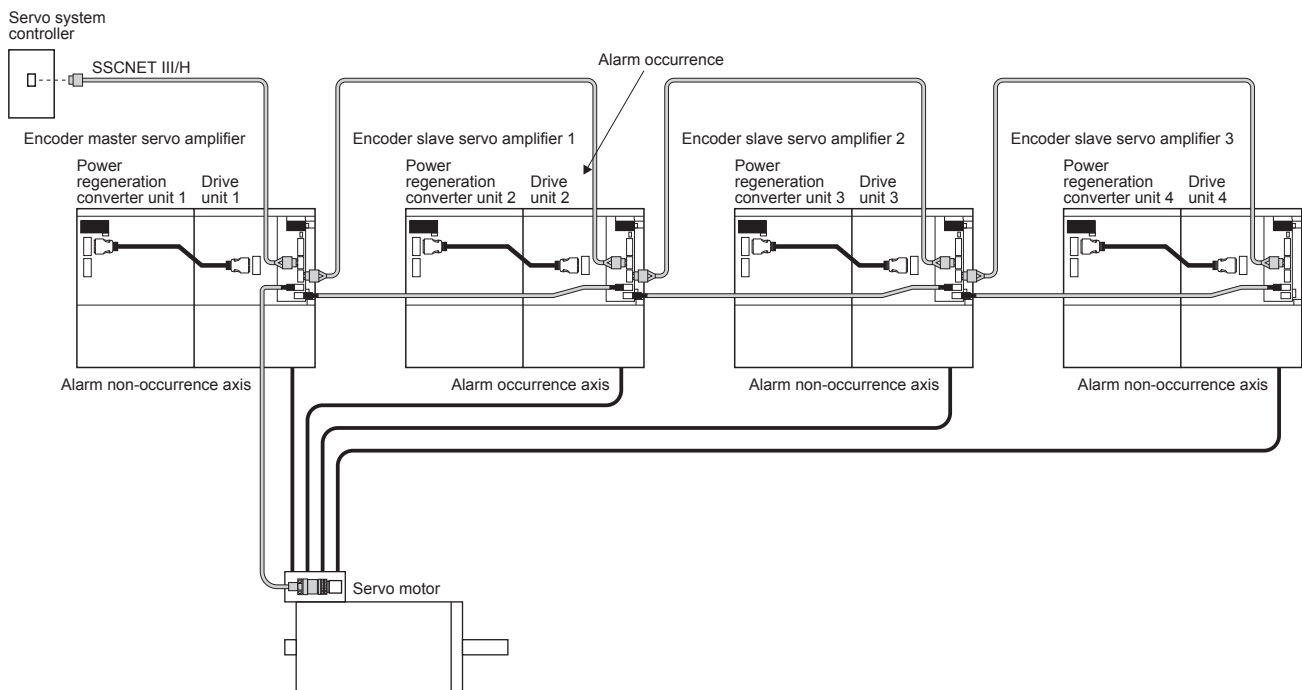

When you use the forced stop deceleration function

Set [Pr. PA04] to "2 _ _ _" (initial value).

Time constant setting

When you use the forced stop deceleration function, set the same value in the forced stop deceleration time constant [Pr. PC24] of the drive unit and the rapid stop deceleration time set with the Motion controller.

■ Difference between the deceleration time constant and the deceleration time

The following shows the difference between the forced stop deceleration time constant and the rapid stop deceleration time.

- Forced stop deceleration time constant (Drive unit)

The time for the servo motor to stop from the rated speed

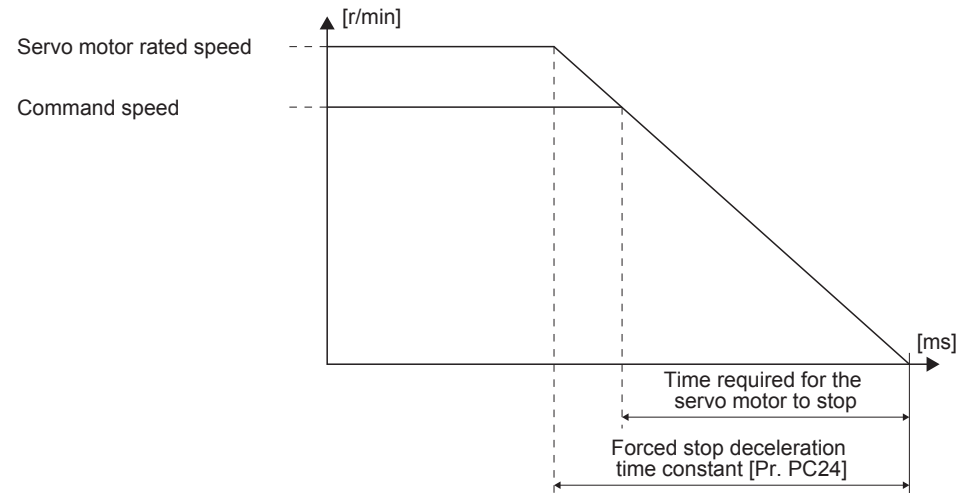

- Rapid stop deceleration time (Motion controller)

Time for the servo motor to stop from the speed limit value of the Motion controller

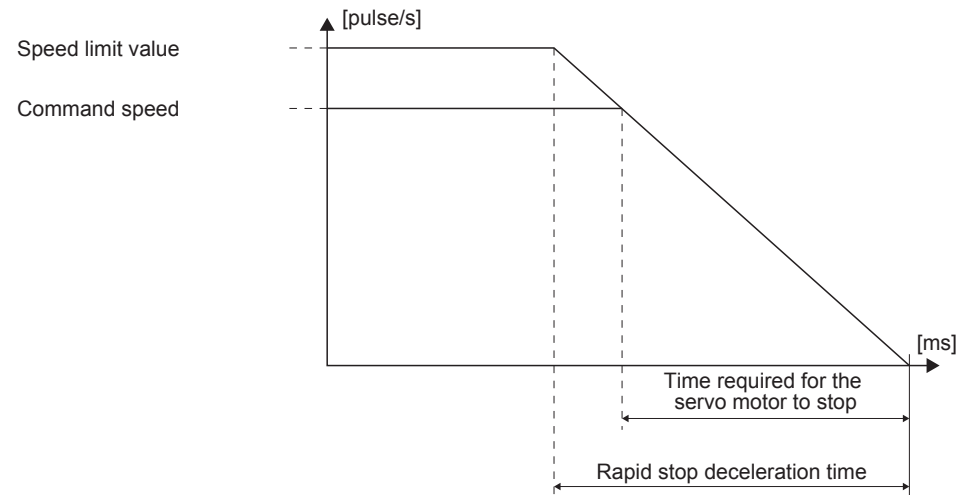

■Formula for calculating the rapid stop deceleration time

$$\text{Rapid stop deceleration time [ms]} = \frac{\text{Forced stop deceleration time constant [ms]} \times \text{Speed limit value [pulse/s]}^{*1} \times 60 [s]}{\text{Servo motor rated speed [r/min]} \times 4194304 [\text{pulse}]}$$

*1 In addition to [pulse/s], [mm/min], [inch/min], and [degree/min] are used for the control unit of the Motion controller. When a control unit other than [pulse/s] is used, convert the unit into [pulse/s] to calculate the rapid stop deceleration time.

■Setting example of the rapid stop deceleration time

Condition

Servo motor rated speed: 2000 [r/min] (Depends on the servo motor)

Speed limit value: 2097152 [pulse/s] (Depends on users, setting by the motion controller)

Forced stop deceleration time constant: 1000 [ms] (Depends on users, setting by the drive unit)

$$\text{Rapid stop deceleration time [ms]} = \frac{1000 \times 2097152 \times 60}{2000 \times 4194304} = 15 [\text{ms}]$$

Therefore, set the rapid stop deceleration time of the motion controller to 1 ms.

If an alarm subject to the forced stop deceleration function occurs

The following timing chart shows that an alarm occurs in any axis in the parallel drive system.

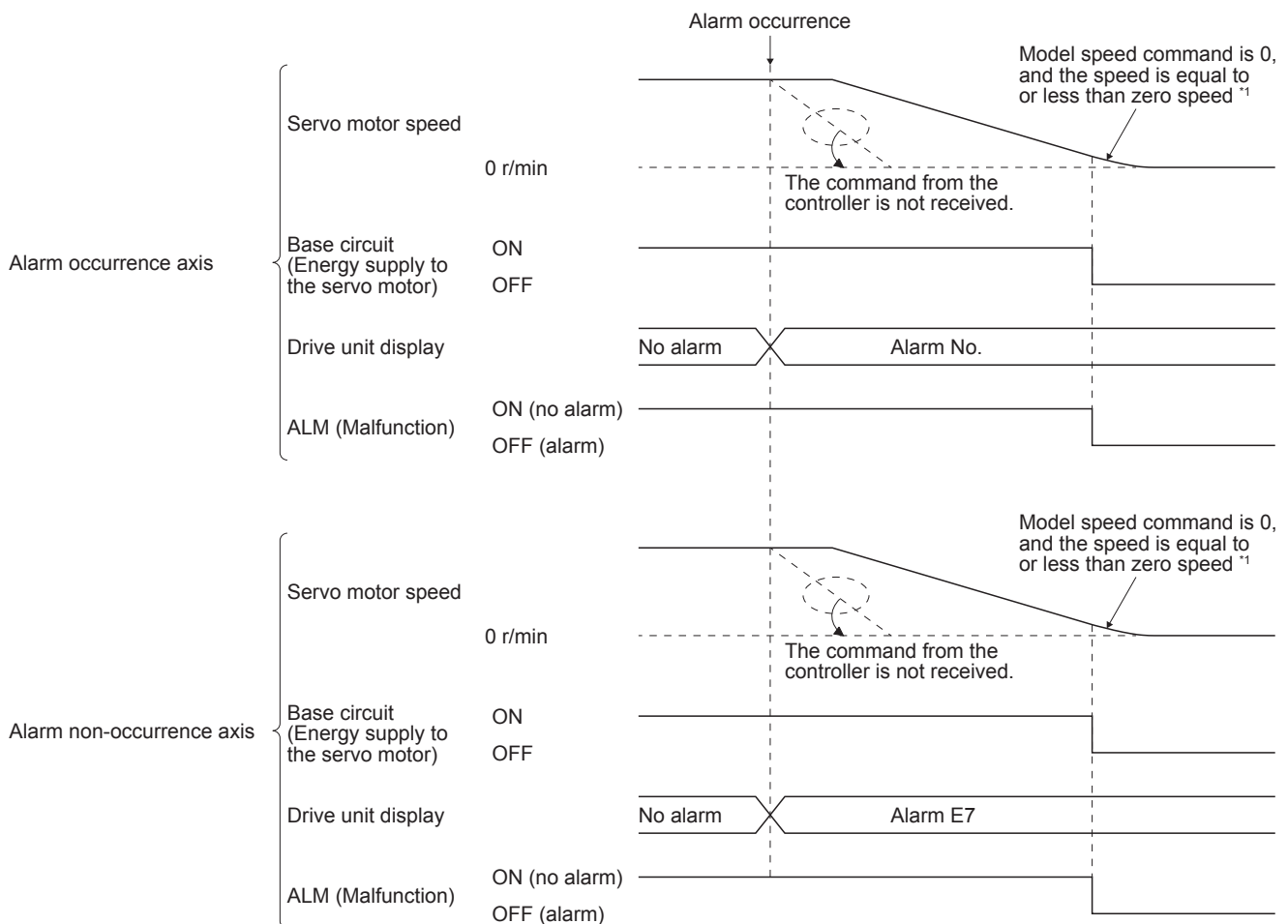

*1 The model speed command is a speed command generated in the servo amplifier for forced stop deceleration of the servo motor.

If an alarm not subject to the forced stop deceleration function occurs

Point

When the dynamic brake is used, a brake operation delay time occurs. For details, refer to the specifications of the magnetic contactor you use.

The following timing chart shows that an alarm occurs in any axis in the parallel drive system.

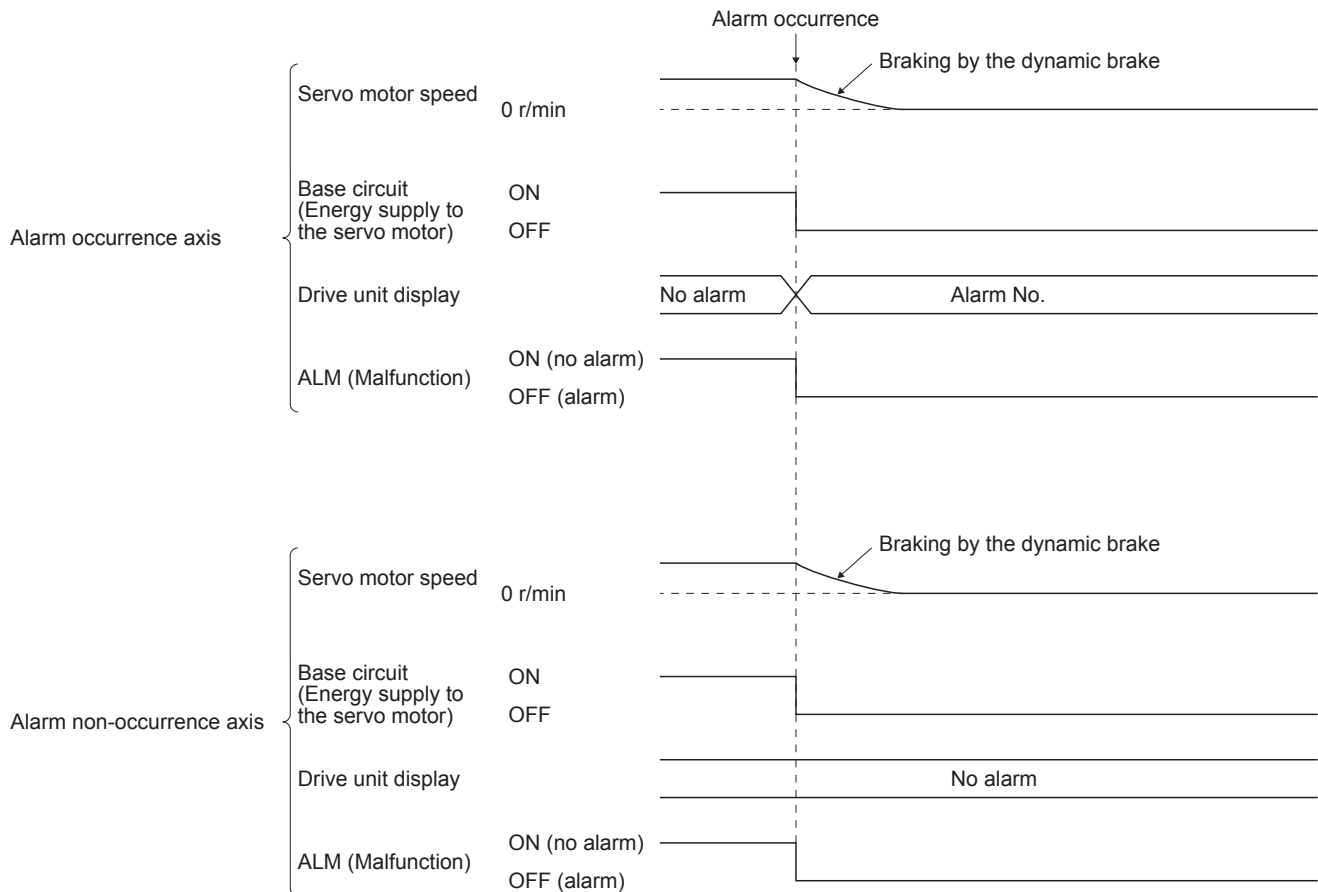

When SSCNET III/H communication is shut off

Point

When an SSCNET III/H communication shut-off occurs in a servo amplifier, the servo amplifier and subsequent servo amplifiers show "AA" on the display.

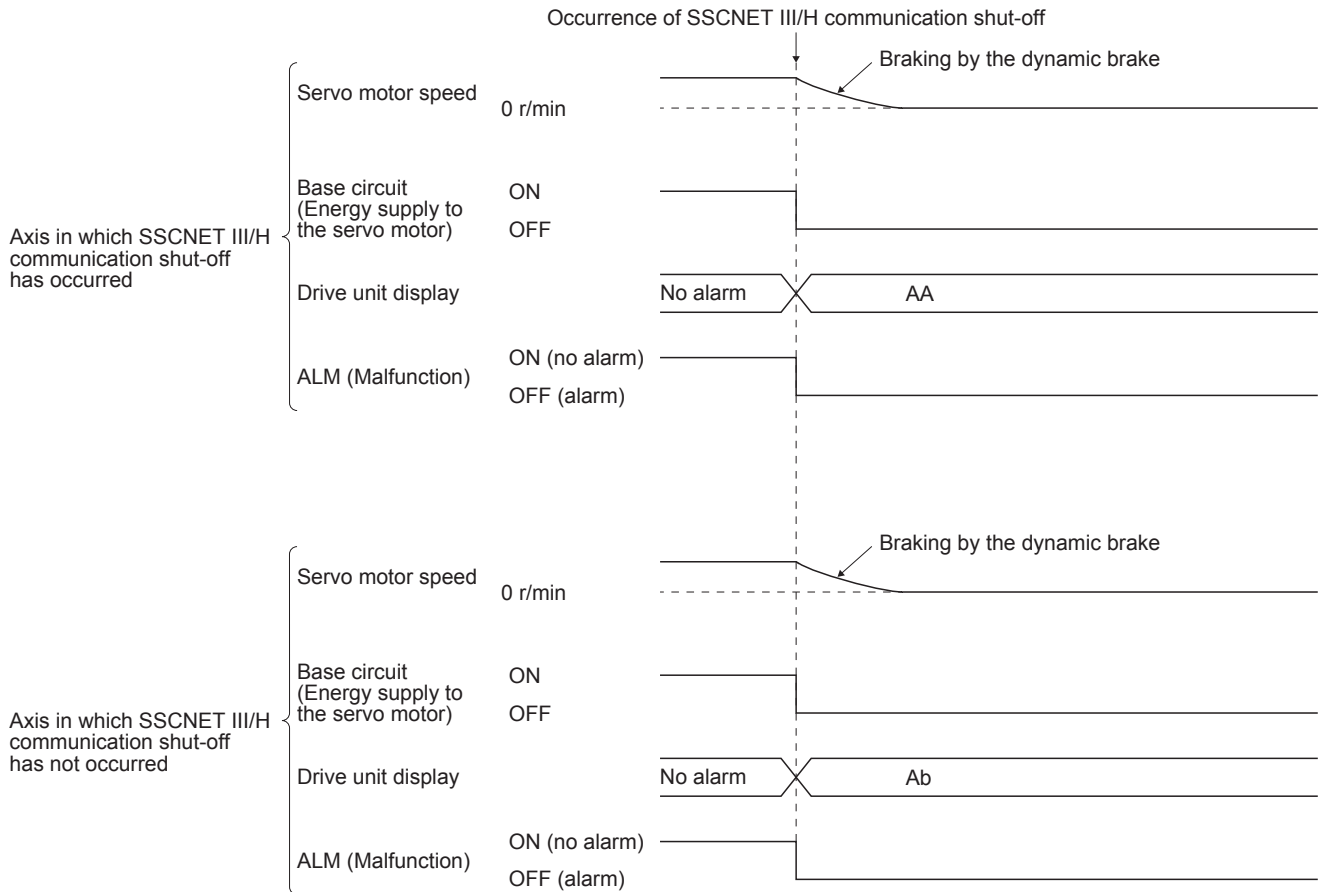

When you do not use the forced stop deceleration function

Set [Pr. PA04] to "0 ___". The operation status of the servo motor during an alarm is the same as that of when the forced stop deceleration function is used.

Page 27 When you use the forced stop deceleration function

3.3 Grounding

⚠ WARNING

- Ground the power regeneration converter unit, drive unit, and servo motor securely.
- To prevent an electric shock, be sure to connect the protective earth (PE) terminal (marked ⊕) of the power regeneration converter unit and the drive unit to the protective earth (PE) of the cabinet.

Point

For items other than the ones described in this section, refer to section 3.3 in "MR-CV_/MR-CR55K_/MR-J4-DU_(-RJ) Instruction Manual".

Capacitances exist between input/output lines of the servo and other lines or the ground, and in the servo motor, through which a leakage current flows. For a servo with a large capacity, a leakage current including a high-frequency of several 100 mA may flow.

Note the following.

- To prevent an electric shock, be sure to ground the drive unit, power regeneration converter unit, and servo motor.
- To lower the impedance of the grounding wire, use the wire of the size equal to or greater than that shown in section 8.4 in "MR-CV_/MR-CR55K_/MR-J4-DU_(-RJ) Instruction Manual", and make the wire as short as possible. Stranded wires or braided wires are helpful to lower impedance.
- Prevent multiple points from being grounded. Ground one point. Grounding multiple points may generate a potential difference between the grounded points by the impedance of the grounding wires. If the units cannot be grounded to one point, connect the grounding wires to a copper bar and ground it to one point.

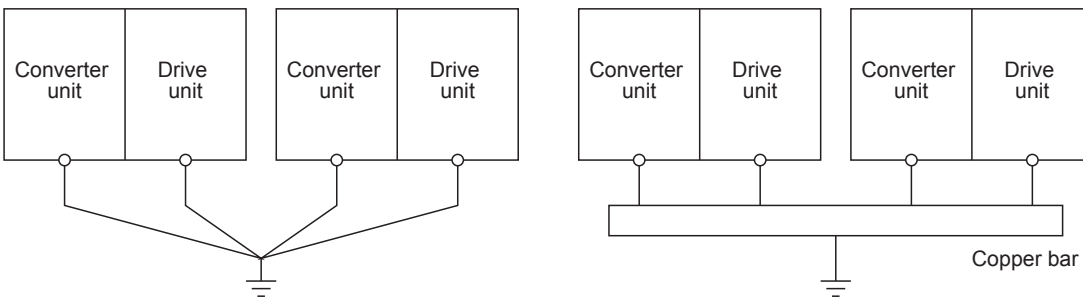

- Leakage currents including high-frequency components flow through the grounding wires of the drive unit, power regeneration converter unit, and servo motor. Route the grounding wires of noise-sensitive devices separately.

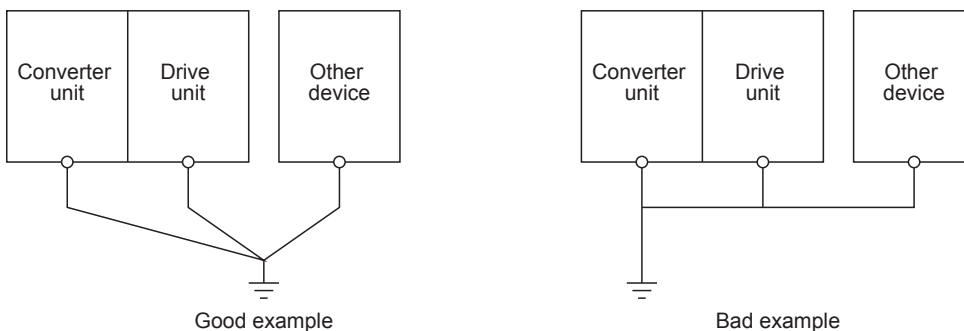

- Route the grounding wires as far away from the input/output lines of noise-sensitive devices as possible, and run the grounding wires in parallel to each other as short as possible.
- Connect the grounding wire from the servo motor to the protective earth (PE) terminal of the drive unit. Put the grounding wires of the drive unit and the power regeneration converter unit together into one on the protective earth (PE) terminal of the cabinet, and then connect to the ground. Connect the grounding wire of the servo motor to only the drive unit of the encoder master servo amplifier. If the grounding wire of the servo motor is connected to two or more drive units, the circulating current may pass through the grounding wire depending on wiring conditions. When connecting grounding wires to two or more drive units, be sure to twist the wires of the drive unit power outputs (U/V/W).

4 STARTUP

WARNING

- When executing a test run, follow the notice and procedures in this instruction manual. Otherwise, it may cause a malfunction, damage to the machine, or injury.
- Do not operate the switches with wet hands. Otherwise, it may cause an electric shock.

CAUTION

- Before starting operation, check the parameters. Improper settings may cause some machines to operate unexpectedly.
- The heat sink of the power regeneration converter unit and drive unit, and the servo motor, etc. may be hot while power is on and for some time after power-off. Take safety measures such as providing covers to avoid accidentally touching them by hands and parts such as cables.
- During operation, never touch the rotor of the servo motor. Otherwise, it may cause injury.
- Before wiring, switch operation, etc., eliminate static electricity. Otherwise, it may cause a malfunction.

Point

For parallel drive systems, test operation cannot be performed with MR Configurator2. Perform test operation with the controller.

The following items are the same as those for MR-J4-_B_(-RJ). Refer to the section of the detailed explanation field for details. "MR-J4-_B_" means "MR-J4-_B_(-RJ) Servo Amplifier Instruction Manual". "MR-J4-DU_B_" means "MR-CV_/MR-CR55K_/MR-J4-DU_(-RJ) Instruction Manual".

Item	Detailed explanation
Switch setting and display of the drive unit	MR-J4-_B_ section 4.3
Switch setting and operation section of power regeneration converter unit	MR-J4-DU_B_ section 3.4

4.1 Switching power on for the first time

Start up the parallel drive system in the following procedure. Once settings are made, they do not need to be reset. When changes are made to the system settings of the Motion controller, and the drive unit is replaced, start up the system in the following procedure again.

"MR-J4-_B_" means "MR-J4-_B_(-RJ) Servo Amplifier Instruction Manual". "MR-J4-DU_B_" means "MR-CV_/MR-CR55K_/MR-J4-DU_(-RJ) Instruction Manual".

Setting classification	Step	Description	Reference
Servo amplifier	1. Wiring check	Check whether the power regeneration converter unit, drive unit, and servo motor are wired correctly.	MR-J4-DU_B_ section 3.4
	2. Surrounding environment check	Check the surrounding environment of the power regeneration converter unit, the drive unit and the servo motor.	MR-J4-_B_ section 4.1.3
Controller	3. Controller setting	Make the controller settings (normal and the following settings specific to the parallel drive system).	—
	4. Controller power on	—	—
	5. System setting	The parallel drive system is identified as the one axis of the servo amplifier in the SSCNET configuration of MT Developer2. Set the system settings with the encoder master servo amplifier. When the system is set with the encoder slave servo amplifier, an error may occur.	—
	6. Servo data setting	Set the following servo parameters with MR Configurator2 of MT Developer2. Set the servo parameter for the drive unit of the encoder master servo amplifier. <ul style="list-style-type: none"> • [Pr. PA02 Regenerative option] • [Pr. PA17 Servo motor series setting] • [Pr. PA18 Servo motor type setting] • [Pr. PC04 Function selection C-1] • [Pr. PF37 Parallel drive - Encoder ID setting 1] • [Pr. PF40 Parallel drive - Servo motor side system setting] • [Pr. PF41 Function selection F-12] • [Pr. PF42 Function selection F-13] 	Chapter 5
	7. Controller reset	—	—
Servo amplifier	8. MR-CV55K4_ power regeneration converter unit setting	Set the converter setting rotary switch (SW1) to "0".	—
	9. Axis number setting of the drive unit	Check the control axis No. set with the auxiliary axis number setting switches (SW2-3 and SW2-4) and the axis selection rotary switch (SW1) match the control axis No. set with the servo system controller.	MR-J4-_B_ section 4.3.1 (3)
	10. Drive unit and Converter unit power on	The 3-digit, 7-segment LED of the drive unit displays the following. Encoder master servo amplifier: 16 Encoder slave servo amplifier: 16 [AL. 16 Encoder initial communication error 1] will occur because the servo parameters set for the encoder master servo amplifier via the controller (MT Developer 2) are not applied. Apply the servo parameters to the drive unit in the next step.	—
	11. Drive unit and Converter unit power off	Enable the servo parameters set for the encoder master amplifier via the controller (MT Developer 2).	—
	12. Drive unit and Converter unit power on	The startup is completed. The 3-digit, 7-segment LED of the drive unit displays the following. Encoder master servo amplifier: b## Encoder slave servo amplifier: b## "##" means each axis number. The decimal point in the 2nd digit is lit on the 3-digit, 7-segment LED display of the drive unit set for the encoder slave servo amplifier.	—

4.2 Startup

Startup of the MR-J4-DU_B4-RJ100 is the same as that of the MR-J4-_B_(-RJ). For details, refer to section 4.2 in "MR-J4-_B_(-RJ) Servo Amplifier Instruction Manual".

The power regeneration converter unit shows "C" (ready-off) on the display at power-on.

When an alarm occurs or EM1 (Forced stop) is disabled in the power regeneration converter unit, the operation will stop.

5 PARAMETERS

CAUTION

- Never make a drastic adjustment or change to the parameter values as doing so will make the operation unstable.
- Do not change the parameter settings as described below. Doing so may cause an unexpected condition, such as failing to start up the drive unit. · Changing the values of the parameters for manufacturer setting · Setting a value out of the range · Changing the fixed values in the digits of a parameter
- When you write parameters with the controller, make sure that the control axis No. of the drive unit is set correctly. Otherwise, the parameter settings of another axis may be written, possibly causing the drive unit to be an unexpected condition.

Point

When you connect the drive unit to a servo system controller, servo parameter values of the servo system controller will be written to each parameter.

Setting may not be made to some parameters and their ranges depending on the servo system controller model, drive unit software version, and MR Configurator2 software version. For details, refer to the servo system controller user's manual.

The parameter whose symbol is preceded by * is enabled with the following conditions.

- *: After setting the parameter, cycle the power or reset the controller.
- **: After setting the parameter, cycle the power.

Set a value to each "x" in the "Setting digit" columns.

Do not change parameters during servo-on.

Be sure to set the same setting in parameters of the encoder master servo amplifier and those of the encoder slave servo amplifiers.

When the parameters are written with MR Configurator2, be sure to be connected via the motion controller. If parameters are written with MR Configurator2 by directly connecting to the USB port on the drive unit, parameters in the drive unit and the controller cannot be updated correctly.

For the advanced vibration suppression control II (vibration suppression control tuning) and the adaptive filter II (adaptive tuning), "Automatic setting" is invalid. Only "Manual setting" is valid.

The following shows parameter settings exclusively for the driver unit. Other parameters are the same as those of MR-J4-_B_(-RJ). Refer to chapter 5 in "MR-J4-_B_(-RJ) Servo Amplifier Instruction Manual".

[Pr. PA01 Operation mode (**STY)]

For parallel drive systems, the operation mode selection and J3 compatibility mode are unavailable. Do not change those parameters.

Setting digit	Explanation	Initial value
___x	For manufacturer setting	0h
__x_	Operation mode selection 0: Standard control mode 1: Fully closed loop control mode 4: Linear servo motor control mode 6: DD motor control mode Setting any value other than "0" will trigger [AL. 37 Parameter error].	0h
_x__	For manufacturer setting	0h
x___	Compatibility mode selection For parallel drive systems, the J3 compatibility mode is unavailable. Do not set this digit to "0". 0: J3 compatibility mode 1: J4 mode	1h

[Pr. PA02 Regenerative option (**REG)]

For parallel drive systems, the regenerative option is unavailable. Set "0700" to this parameter.

Setting digit	Explanation	Initial value
__ x x	Regenerative option selection 00: Regenerative option is not used, or when you use a regenerative option, set the regenerative option with the converter unit. When using the drive unit with the converter unit, set this value regardless of whether or not the regenerative option and brake unit are used.	00h
_ x __	Converter unit selection For parallel drive systems, the MR-CR_ is unavailable. Do not set this digit to "0". 0: MR-CR_ 7: MR-CV_ Setting a value other than "0" or "7" will trigger [AL. 37].	0h
x ___	Protection coordination mode selection between converter and drive unit For parallel drive systems, do not set this digit to "Protection coordination mode disabled (stand-alone drive) (4 ___)". 0: Protection coordination mode enabled 4: Protection coordination mode disabled (stand-alone drive)	0h

[Pr. PA17 Servo motor series setting (**MSR)]

Select any servo motor with [Pr. PA17] and [Pr. PA18]. Set this and [Pr. PA18] at a time. Refer to the following table for settings.

Motor series	Servo motor	[Pr. PA17]	[Pr. PA18]
HG-JR	HG-JR110K24W0C	0132h	A102h
	HG-JR150K24W0C	0132h	A502h
	HG-JR180K24W0C	0132h	A802h
	HG-JR200K24W0C	0132h	B002h
	HG-JR220K24W0C	0132h	B202h

Initial value [unit]: 0000h

[Pr. PA18 Servo motor type setting (**MTY)]

Select any servo motor with [Pr. PA17] and [Pr. PA18]. Set this and [Pr. PA17] at a time. Refer to the table of [Pr. PA17] for settings.

Initial value [unit]: 0000h

[Pr. PA20 Tough drive setting (*TDS)]

Alarms may not be avoided with the tough drive function depending on the situations of the power supply and load fluctuation. You can assign MTTR (During tough drive) to pins CN3-9, CN3-13, and CN3-15 with [Pr. PD07] to [Pr. PD09].

Setting digit	Explanation	Initial value
___ x	For manufacturer setting	0h
__ x _	Vibration tough drive selection 0: Disabled 1: Enabled Selecting "1" enables to suppress vibrations by automatically changing the setting values of [Pr. PB13 Machine resonance suppression filter 1] and [Pr. PB15 Machine resonance suppression filter 2] in case that the vibration exceeds the value of the oscillation level set in [Pr. PF23]. For details, refer to section 7.3 in "MR-J4-_B_(-RJ) Servo Amplifier Instruction Manual".	0h
_ x __	SEMI-F47 function selection A combination of the MR-CV55K4_ power regeneration converter unit and drive unit does not comply with SEMI-F47 standard. 0: Disabled 1: Enabled When "MR-CV_ (_ 7 ___)" is selected in "Converter unit selection" of [Pr. PA02], setting "Enabled (_ 1 ___)" in this parameter will trigger [AL. 37 Parameter error].	0h
x ___	For manufacturer setting	0h

[Pr. PA21 Function selection A-3 (*AOP3)]

Setting digit	Explanation	Initial value
___x	One-touch tuning function selection For parallel drive systems, the one-touch tuning is unavailable. The parameter setting is invalid. 0: Disabled 1: Enabled	1h
__x_	For manufacturer setting	0h
_x__		0h
x___		0h

[Pr. PB01 Adaptive tuning mode (adaptive filter II) (FILT)]

Set the adaptive tuning.

Setting digit	Explanation	Initial value
___x	Filter tuning mode selection Select the adjustment mode of the machine resonance suppression filter 1. For parallel drive systems, "Automatic setting (_ _ _ 1)" is invalid. 0: Disabled 1: Automatic setting 2: Manual setting	0h
__x_	For manufacturer setting	0h
_x__		0h
x___	Tuning accuracy selection 0: Standard 1: The frequency is estimated more accurately in the high accuracy mode compared to the standard mode. However, the tuning sound may be larger in the high accuracy mode.	0h

[Pr. PB02 Vibration suppression control tuning mode (advanced vibration suppression control II) (VRFT)]

Set the vibration suppression control tuning.

Setting digit	Explanation	Initial value
___x	Vibration suppression control 1 tuning mode selection Select the tuning mode of the vibration suppression control 1. For parallel drive systems, "Automatic setting (_ _ _ 1)" is invalid. 0: Disabled 1: Automatic setting 2: Manual setting	0h
__x_	Vibration suppression control 2 tuning mode selection Select the tuning mode of the vibration suppression control 2. To enable the digit, select "3 inertia mode (_ _ _ 1)" of "Vibration suppression mode selection" in [Pr. PA24 Function selection A-4]. For parallel drive systems, "Automatic setting (_ _ 1 _)" is invalid. 0: Disabled 1: Automatic setting 2: Manual setting	0h
_x__	For manufacturer setting	0h
x___		0h

[Pr. PC04 Function selection C-1 (**COP1)]

Select an encoder cable communication method.

Setting digit	Explanation	Initial value
___x	For manufacturer setting	0h
__x_		0h
_x__		0h
x___	Encoder cable communication method selection For parallel drive systems, the two-wire type is unavailable. Set this digit to "1". 0: Two-wire type 1: Four-wire type	0h

[Pr. PC24 Forced stop deceleration time constant (RSBR)]

Set a deceleration time constant for the forced stop deceleration function.

Set the time taken from the rated speed to 0 r/min in a unit of ms. Setting "0" will be 100 ms.

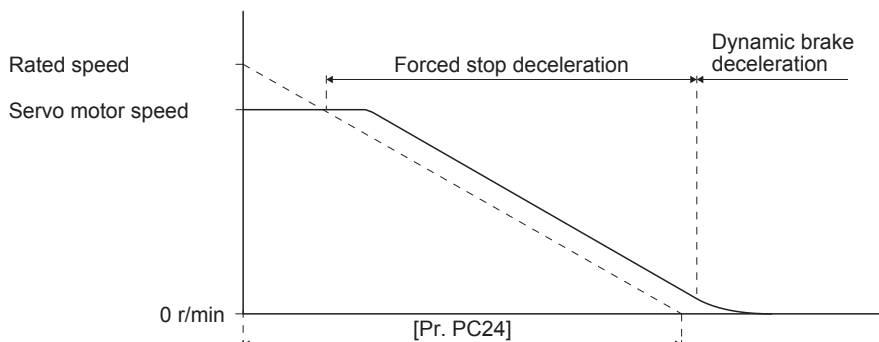

[Precautions]

- If the servo motor torque is saturated at the maximum torque during a forced stop deceleration because the set time is too short, the time to stop will be longer than the set time constant.
- [AL. 50 Overload alarm 1] or [AL. 51 Overload alarm 2] may occur during forced stop deceleration, depending on the set value.
- After an alarm that leads to a forced stop deceleration, if an alarm that does not lead to a forced stop deceleration occurs or if the control circuit power supply is cut, dynamic braking will start regardless of the deceleration time constant setting.
- Set the time the same as the rapid stop deceleration time set with the controller. If a shorter time is set, [AL. 52 Error excessive] may occur. For the setting method, refer to the following.

☞ Page 27 Time constant setting

Initial value [unit]: 100 [ms]

Setting range: 0 to 20000

[Pr. PF03 Function selection F-5 (*FOP5)]

Setting digit	Explanation	Initial value
___x	For manufacturer setting	0h
__x_		0h
_x__	Protection coordination mode function between converter and drive unit selection For parallel drive systems, set this digit to "0". 0: Disabled 1: Enabled When "Enabled (_ 1 __)" is selected in this parameter, the setting value in "Protection coordination mode selection between converter and drive unit" of [Pr. PA02] is enabled.	0h
x___	For manufacturer setting	0h

[Pr. PF07 Function selection F-6 (*FOP6)]

Setting digit	Explanation	Initial value
___x	For manufacturer setting	0h
__x_		0h
_x__	Magnetic contactor shut-off selection at STO input For parallel drive systems, the magnetic contactor turns off when STO is inputted (when [AL. 95] has occurred). The setting value of "1" is disabled. 0: The magnetic contactor is turned off when STO is inputted (when [AL. 95] has occurred). 1: The magnetic contactor is kept on when STO is inputted (when [AL. 95] has occurred).	0h
x___	Magnetic contactor shut-off selection at forced stop input For parallel drive systems, the magnetic contactor turns off when the forced stop is inputted (when [AL. E6] has occurred). 0: Turns the magnetic contactor off when the forced stop is input (when [AL. E6] has occurred). 1: Keeps the magnetic contactor on when the forced stop is input (when [AL. E6] has occurred).	0h

[Pr. PF25 SEMI-F47 function - Instantaneous power failure detection time (CVAT)]

A combination of the MR-CV55K4_ power regeneration converter unit and drive unit does not comply with SEMI-F47 standard. The parameter setting is invalid.

Initial value [unit]: 200 [ms]

[Pr. PF37 Parallel drive - Encoder ID setting 1 (**ENID1)]

Set a servo motor-side encoder ID. Setting an encoder ID switches encoder communication types. Setting any value other than the following will trigger [AL. 37 Parameter error].

When the MR-D30 functional safety unit is mounted on the encoder master servo amplifier

Setting value	Servo motor
0444	HG-JR110K24W0C HG-JR150K24W0C HG-JR180K24W0C HG-JR200K24W0C HG-JR220K24W0C

When the MR-D30 functional safety unit is not mounted on the encoder master servo amplifier

Setting value	Servo motor
0044	HG-JR110K24W0C HG-JR150K24W0C HG-JR180K24W0C HG-JR200K24W0C HG-JR220K24W0C

Initial value [unit]: 0000h

[Pr. PF40 Parallel drive - Servo motor side system setting (**EMS)]

Set the servo motor-side encoder slave servo amplifiers.

Setting digit	Explanation	Initial value
__ x x	Control axis No. setting of the encoder master servo amplifier Set the control axis No. of the encoder master servo amplifier in hexadecimal. When "00" is set, the parameter setting is invalid.	00h
x x __	The number setting of the encoder master servo amplifier Set the number of encoder slave servo amplifiers. When "00" is set, the parameter setting is invalid.	00h

Setting example:

If the control axis No. of the encoder master servo amplifier is 17 (11h), and three encoder slave servo amplifiers are used, set "0311".

[Pr. PF41 Function selection F-12 (*FOP12)]

Enable/disable [AL. 46 Servo motor overheat] detection. For servo motors without a thermistor, [AL. 46 Servo motor overheat] detection is disabled regardless of the setting. When [AL. 46 Servo motor overheat] detection is enabled, temperature monitoring is also enabled regardless of the setting of [Pr. PF42 Parallel drive - Temperature monitor setting].

Setting digit	Explanation	Initial value
___ x (HEX)	___ x (BIN) Encoder master servo amplifier - Motor thermistor setting 0: [AL. 46 Servo motor overheat] detection enabled 1: [AL. 46 Servo motor overheat] detection disabled	0h

[Pr. PF42 Function selection F-13 (*FOP13)]

Enable/disable temperature monitoring. For servo motors without a thermistor, temperature monitoring is disabled regardless of the set value. When [AL. 46 Servo motor overheat] detection is enabled in [Pr. PF41 Parallel drive - Motor thermistor setting], temperature monitoring is also enabled regardless of the setting of [Pr. PF42 Parallel drive - Temperature monitor setting].

Setting digit	Explanation	Initial value
___x (HEX)	___x (BIN) Encoder master servo amplifier - Temperature monitor setting 0: Temperature monitoring enabled 1: Temperature monitoring disabled	0h

6 TROUBLESHOOTING

Point

- The forced stop deceleration does not function for alarms not subject to the forced stop deceleration function.

For parallel drive systems, if [AL. 34 SSCNET receive error 1] or [AL. 36 SSCNET receive error 2] occurs, the servo motor stops with the dynamic brake (DB), not with forced stop deceleration (SD).

6.1 Troubleshooting for MR-CV_ power regeneration converter unit

When an alarm or warning is displayed, refer to "MELSERVO-J4 Servo Amplifier Instruction Manual (Troubleshooting)" to remove the failure.

 MELSERVO-J4 Servo Amplifier Instruction Manual (Troubleshooting)

When an alarm occurs, ALM (Malfunction) will turn off.

Explanation for the lists

No./Name

Indicates each No./Name of alarms or warnings.

Alarm deactivation

After the cause of the alarm has been removed, the alarm can be deactivated by any of the methods marked ○ in the alarm deactivation column. Warnings are automatically canceled after the cause of occurrence is removed. Alarms are deactivated by alarm reset, CPU reset, or power cycling.

Alarm deactivation	Explanation
Alarm reset	1. Turn on RES (Reset) with an input device.*1 2. Input the servo-on command for the drive unit connected with the protection coordination cable.
CPU reset	Reset the controller itself.*2
Power cycling	Turn the power off and on again.

*1 Deactivate the alarm in servo-off status. If the alarm is deactivated in servo-on status, [AL. 1B Converter error] will occur.

*2 If the protection coordination cable is not connected, the alarm cannot be deactivated by CPU reset.

Alarm list

No.	Name	Alarm deactivation		
		Alarm reset	CPU reset	Power cycling
61	Overcurrent	—	○	○
62	Frequency error	—	○	○
66	Process error	—	○	○
67	Open phase	—	○	○
68	Watchdog	—	—	○
69	Ground fault	○	○	○
6A	MC drive circuit error	—	○	○
6B	Inrush current suppression circuit error	—	○	○
6C	Main circuit error	—	○	○
6E_*1	Board error	—	—	○
70	Converter forced stop error	—	○	○
71	Undervoltage	○	○	○
72	Cooling fan error	—	○	○
73	Regenerative error	○*2	○*2	○*2
75	Overvoltage	○	○	○
76	Switch setting error	—	—	○
77	Main circuit device overheat	—	○*2	○*2
7E	Overload 1	○*2	○*2	○*2
7F	Overload 2	○*2	○*2	○*2

*1 Digits of " _ " may be displayed. Remedies for the alarm is the same as those for [AL. 6E].

*2 After resolving the source of trouble, cool the equipment for approximately 30 minutes.

Warning list

No.	Name
E9	Instantaneous power failure warning
EA	External forced stop warning
EB	Excessive regeneration warning
EC	Overload warning
EE	Cooling fan speed reduction warning

6.2 Troubleshooting for drive unit

Point

[AL. 37 Parameter error] and warnings (except [AL. F0 Tough drive warning]) are not recorded in the alarm history.

When an error occurs during operation, the corresponding alarm or warning is displayed. When an alarm or warning is displayed, refer to "MELSERVO-J4 Servo Amplifier Instruction Manual (Troubleshooting)" to remove the failure.

 MELSERVO-J4 Servo Amplifier Instruction Manual (Troubleshooting)

When an alarm occurs, ALM (Malfunction) will turn off.

Explanation for the lists

No./Name/Detail No./Detail name

Indicates the No./name/detail No./detail name of alarms or warnings.

Stop method

For the alarms and warnings in which "SD" is written in the stop method column, the servo motor stops with the dynamic brake after forced stop deceleration. For the alarms and warnings in which "DB" or "EDB" is written in the stop method column, the servo motor stops with the dynamic brake without forced stop deceleration.

Alarm deactivation

After the cause of the alarm has been removed, the alarm can be deactivated by any of the methods marked ○ in the alarm deactivation column. Warnings are automatically canceled after the cause of occurrence is removed. Alarms are deactivated by alarm reset, CPU reset, or power cycling.

Alarm deactivation	Explanation
Alarm reset	1. Error reset command from the controller 2. Click "Occurred Alarm Reset" in the "Alarm Display" window of MR Configurator2.
CPU reset	Reset the controller itself.
Power cycling	Turn the power off and on again.

Alarm list

Alarm		Details		Stop method ^{*2} ^{*3}	Alarm deactivation		
No.	Name	No.	Name		Alarm reset	CPU reset	Power cycling
10	Undervoltage	10.1	Voltage drop in the control circuit power	EDB	○	○	○
		10.2	Voltage drop in the main circuit power	SD	○	○	○
11	Switch setting error	11.1	Axis number setting error/station number setting error	DB	—	—	○
		11.2	Disabling control axis setting error	DB	—	—	○
12	Memory error 1 (RAM)	12.1	RAM error 1	DB	—	—	○
		12.2	RAM error 2	DB	—	—	○
		12.3	RAM error 3	DB	—	—	○
		12.4	RAM error 4	DB	—	—	○
		12.5	RAM error 5	DB	—	—	○
		12.6	RAM error 6	DB	—	—	○
13	Clock error	13.1	Clock error 1	DB	—	—	○
		13.2	Clock error 2	DB	—	—	○
		13.3	Clock error 3	DB	—	—	○
14	Control process error	14.1	Control process error 1	DB	—	—	○
		14.2	Control process error 2	DB	—	—	○
		14.3	Control process error 3	DB	—	—	○
		14.4	Control process error 4	DB	—	—	○
		14.5	Control process error 5	DB	—	—	○
		14.6	Control process error 6	DB	—	—	○
		14.7	Control process error 7	DB	—	—	○
		14.8	Control process error 8	DB	—	—	○
		14.9	Control process error 9	DB	—	—	○
		14.A	Control process error 10	DB	—	—	○
		14.B	Control process error 11	DB	—	—	○
		14.C	Control process error 12	DB	—	—	○
		14.D	Control process error 13	DB	—	—	○
15	Memory error 2 (EEP-ROM)	15.1	EEP-ROM error at power on	DB	—	—	○
		15.2	EEP-ROM error during operation	DB	—	—	○
		15.4	Home position information read error	DB	—	—	○

Alarm		Details		Stop method ^{*2} ^{*3}	Alarm deactivation		
No.	Name	No.	Name		Alarm reset	CPU reset	Power cycling
16	Encoder initial communication error 1	16.1	Encoder initial communication - Receive data error 1	DB	—	—	○
		16.2	Encoder initial communication - Receive data error 2	DB	—	—	○
		16.3	Encoder initial communication - Receive data error 3	DB	—	—	○
		16.4	Encoder initial communication - Encoder malfunction ^{*6}	DB	—	—	○
		16.5	Encoder initial communication - Transmission data error 1	DB	—	—	○
		16.6	Encoder initial communication - Transmission data error 2	DB	—	—	○
		16.7	Encoder initial communication - Transmission data error 3	DB	—	—	○
		16.8	Encoder initial communication - Incompatible encoder ^{*6}	DB	—	—	○
		16.A	Encoder initial communication - Process error 1	DB	—	—	○
		16.B	Encoder initial communication - Process error 2	DB	—	—	○
		16.C	Encoder initial communication - Process error 3	DB	—	—	○
		16.D	Encoder initial communication - Process error 4	DB	—	—	○
		16.E	Encoder initial communication - Process error 5	DB	—	—	○
		16.F	Encoder initial communication - Process error 6	DB	—	—	○
17	Board error	17.1	Board error 1	DB	—	—	○
		17.3	Board error 2	DB	—	—	○
		17.4	Board error 3	DB	—	—	○
		17.5	Board error 4	DB	—	—	○
		17.6	Board error 5	DB	—	—	○
		17.7	Board error 7	DB	—	—	○
		17.8	Board error 6 ^{*6}	EDB	—	—	○
		17.9	Board error 8	DB	—	—	○
19	Memory error 3 (Flash-ROM)	19.1	Flash-ROM error 1	DB	—	—	○
		19.2	Flash-ROM error 2	DB	—	—	○
		19.3	Flash-ROM error 3	DB	—	—	○
1A	Servo motor combination error	1A.1	Servo motor combination error 1	DB	—	—	○
		1A.2	Servo motor control mode combination error	DB	—	—	○
		1A.4	Servo motor combination error 2	DB	—	—	○
1B	Converter error	1B.1	Converter unit error	DB	—	—	○
1E	Encoder initial communication error 2	1E.1	Encoder malfunction	DB	—	—	○
		1E.2	Load-side encoder malfunction	DB	—	—	○
1F	Encoder initial communication error 3	1F.1	Incompatible encoder	DB	—	—	○
		1F.2	Incompatible load-side encoder	DB	—	—	○

Alarm		Details		Stop method ^{*2} ^{*3}	Alarm deactivation		
No.	Name	No.	Name		Alarm reset	CPU reset	Power cycling
20	Encoder normal communication error 1	20.1	Encoder normal communication - Receive data error 1	EDB	—	—	○
		20.2	Encoder normal communication - Receive data error 2	EDB	—	—	○
		20.3	Encoder normal communication - Receive data error 3	EDB	—	—	○
		20.5	Encoder normal communication - Transmission data error 1	EDB	—	—	○
		20.6	Encoder normal communication - Transmission data error 2	EDB	—	—	○
		20.7	Encoder normal communication - Transmission data error 3	EDB	—	—	○
		20.9	Encoder normal communication - Receive data error 4	EDB	—	—	○
		20.A	Encoder normal communication - Receive data error 5	EDB	—	—	○
21	Encoder normal communication error 2	21.1	Encoder data error 1	EDB	—	—	○
		21.2	Encoder data update error	EDB	—	—	○
		21.3	Encoder data waveform error	EDB	—	—	○
		21.4	Encoder non-signal error	EDB	—	—	○
		21.5	Encoder hardware error 1	EDB	—	—	○
		21.6	Encoder hardware error 2	EDB	—	—	○
		21.9	Encoder data error 2	EDB	—	—	○
24	Main circuit error	24.1	Ground fault detected at hardware detection circuit	DB	—	—	○
		24.2	Ground fault detected by software detection function	DB	○	○	○
25	Absolute position erased	25.1	Servo motor encoder - Absolute position erased	DB	—	—	○
		25.2	Scale measurement encoder - Absolute position erased	DB	—	—	○
27	Initial magnetic pole detection error	27.1	Initial magnetic pole detection - Abnormal termination	DB	○	—	○
		27.2	Initial magnetic pole detection - Time out error	DB	○	—	○
		27.3	Initial magnetic pole detection - Limit switch error	DB	○	—	○
		27.4	Initial magnetic pole detection - Estimated error	DB	○	—	○
		27.5	Initial magnetic pole detection - Position deviation error	DB	○	—	○
		27.6	Initial magnetic pole detection - Speed deviation error	DB	○	—	○
		27.7	Initial magnetic pole detection - Current error	DB	○	—	○
28	Linear encoder error 2	28.1	Linear encoder - Environment error	EDB	—	—	○
2A	Linear encoder error 1	2A.1	Linear encoder error 1-1	EDB	—	—	○
		2A.2	Linear encoder error 1-2	EDB	—	—	○
		2A.3	Linear encoder error 1-3	EDB	—	—	○
		2A.4	Linear encoder error 1-4	EDB	—	—	○
		2A.5	Linear encoder error 1-5	EDB	—	—	○
		2A.6	Linear encoder error 1-6	EDB	—	—	○
		2A.7	Linear encoder error 1-7	EDB	—	—	○
		2A.8	Linear encoder error 1-8	EDB	—	—	○
2B	Encoder counter error	2B.1	Encoder counter error 1	EDB	—	—	○
		2B.2	Encoder counter error 2	EDB	—	—	○

Alarm		Details		Stop method ^{*2} ^{*3}	Alarm deactivation		
No.	Name	No.	Name		Alarm reset	CPU reset	Power cycling
30	Regenerative error	30.1	Regeneration heat error	DB	○ ^{*1}	○ ^{*1}	○ ^{*1}
		30.2	Regeneration signal error	DB	○ ^{*1}	○ ^{*1}	○ ^{*1}
		30.3	Regeneration feedback signal error	DB	○ ^{*1}	○ ^{*1}	○ ^{*1}
31	Overspeed	31.1	Abnormal motor speed	SD	○	○	○
32	Overcurrent	32.1	Overcurrent detected at hardware detection circuit (during operation)	DB	—	—	○
		32.2	Overcurrent detected at software detection function (during operation)	DB	○	○	○
		32.3	Overcurrent detected at hardware detection circuit (during a stop)	DB	—	—	○
		32.4	Overcurrent detected at software detection function (during a stop)	DB	○	○	○
33	Overvoltage	33.1	Main circuit voltage error	EDB	○	○	○
34	SSCNET receive error 1	34.1	SSCNET receive data error	DB	○	○ ^{*5}	○
		34.2	SSCNET connector connection error	DB	○	○	○
		34.3	SSCNET communication data error	DB	○	○	○
		34.4	Hardware error signal detection	DB	○	○	○
		34.5	SSCNET receive data error (safety observation function)	DB	○	○	○
		34.6	SSCNET communication data error (safety observation function)	DB	○	○	○
35	Command frequency error	35.1	Command frequency error	SD	○	○	○
36	SSCNET receive error 2	36.1	Continuous communication data error	DB	○	○	○
		36.2	Continuous communication data error (safety observation function)	DB	○	○	○
37	Parameter error	37.1	Parameter setting range error	DB	—	○	○
		37.2	Parameter combination error	DB	—	○	○
		37.3	Point table setting error	DB	—	—	○
39	Program error	39.1	Program error	DB	—	—	○
		39.2	Instruction argument external error	DB	—	—	○
		39.3	Register No. error	DB	—	—	○
		39.4	Non-correspondence instruction error	DB	—	—	○
3A	Inrush current suppression circuit error	3A.1	Inrush current suppression circuit error	EDB	—	—	○
3D	Parameter setting error for driver communication	3D.1	Parameter combination error for driver communication on slave	DB	—	—	○
		3D.2	Parameter combination error for driver communication on master	DB	—	—	○
3E	Operation mode error	3E.1	Operation mode error	DB	—	○	○
		3E.6	Operation mode switch error	DB	—	—	○
		3E.8	MR-D30 combination error	DB	—	○	○
42	Servo control error (for linear servo motor and direct drive motor)	42.1	Servo control error by position deviation	EDB	*4	*4	○
		42.2	Servo control error by speed deviation	EDB	*4	*4	○
		42.3	Servo control error by torque/thrust deviation	EDB	*4	*4	○
	Fully closed loop control error (for fully closed loop control)	42.8	Fully closed loop control error by position deviation	EDB	*4	*4	○
		42.9	Fully closed loop control error by speed deviation	EDB	*4	*4	○
		42.A	Fully closed loop control error by position deviation during command stop	EDB	*4	*4	○
45	Main circuit device overheat	45.1	Main circuit device overheat error 1	SD	○ ^{*1}	○ ^{*1}	○ ^{*1}
		45.2	Main circuit device overheat error 2	SD	○ ^{*1}	○ ^{*1}	○ ^{*1}

Alarm		Details		Stop method ^{*2} ^{*3}	Alarm deactivation		
No.	Name	No.	Name		Alarm reset	CPU reset	Power cycling
46	Servo motor overheat	46.1	Abnormal temperature of servo motor 1	SD	○ ^{*1}	○ ^{*1}	○ ^{*1}
		46.2	Abnormal temperature of servo motor 2	SD	○ ^{*1}	○ ^{*1}	○ ^{*1}
		46.3	Thermistor disconnected error	SD	○ ^{*1}	○ ^{*1}	○ ^{*1}
		46.4	Thermistor circuit error	SD	○ ^{*1}	○ ^{*1}	○ ^{*1}
		46.5	Abnormal temperature of servo motor 3	DB	○ ^{*1}	○ ^{*1}	○ ^{*1}
		46.6	Abnormal temperature of servo motor 4	DB	○ ^{*1}	○ ^{*1}	○ ^{*1}
47	Cooling fan error	47.1	Cooling fan stop error	SD	—	—	○
		47.2	Cooling fan speed reduction error	SD	—	—	○
50	Overload 1	50.1	Thermal overload error 1 during operation	SD	○ ^{*1}	○ ^{*1}	○ ^{*1}
		50.2	Thermal overload error 2 during operation	SD	○ ^{*1}	○ ^{*1}	○ ^{*1}
		50.3	Thermal overload error 4 during operation	SD	○ ^{*1}	○ ^{*1}	○ ^{*1}
		50.4	Thermal overload error 1 during a stop	SD	○ ^{*1}	○ ^{*1}	○ ^{*1}
		50.5	Thermal overload error 2 during a stop	SD	○ ^{*1}	○ ^{*1}	○ ^{*1}
		50.6	Thermal overload error 4 during a stop	SD	○ ^{*1}	○ ^{*1}	○ ^{*1}
51	Overload 2	51.1	Thermal overload error 3 during operation	DB	○ ^{*1}	○ ^{*1}	○ ^{*1}
		51.2	Thermal overload error 3 during a stop	DB	○ ^{*1}	○ ^{*1}	○ ^{*1}
52	Error excessive	52.1	Excess droop pulse 1	SD	○	○	○
		52.3	Excess droop pulse 2	SD	○	○	○
		52.4	Error excessive during 0 torque limit	SD	○	○	○
		52.5	Excess droop pulse 3	EDB	○	○	○
54	Oscillation detection	54.1	Oscillation detection error	EDB	○	○	○
56	Forced stop error	56.2	Over speed during forced stop	EDB	○	○	○
		56.3	Estimated distance over during forced stop	EDB	○	○	○
		56.4	Forced stop starting error	EDB	○	○	○
61	Operation error	61.1	Point table setting error	DB	○	—	○
63	STO timing error	63.1	STO1 off	DB	○	○	○
		63.2	STO2 off	DB	○	○	○
		63.5	STO by functional safety unit	DB	○	○	○
64	Functional safety unit setting error	64.1	STO input error	DB	—	—	○
		64.2	Compatibility mode setting error	DB	—	—	○
		64.3	Operation mode setting error	DB	—	—	○
65	Functional safety unit connection error	65.1	Functional safety unit communication error 1	SD	—	—	○
		65.2	Functional safety unit communication error 2	SD	—	—	○
		65.3	Functional safety unit communication error 3	SD	—	—	○
		65.4	Functional safety unit communication error 4	SD	—	—	○
		65.5	Functional safety unit communication error 5	SD	—	—	○
		65.6	Functional safety unit communication error 6	SD	—	—	○
		65.7	Functional safety unit communication error 7	SD	—	—	○
		65.8	Functional safety unit shut-off signal error 1	DB	—	—	○
		65.9	Functional safety unit shut-off signal error 2	DB	—	—	○

Alarm		Details		Stop method ^{*2} ^{*3}	Alarm deactivation		
No.	Name	No.	Name		Alarm reset	CPU reset	Power cycling
66	Encoder initial communication error (safety observation function)	66.1	Encoder initial communication - Receive data error 1 (safety observation function)	DB	—	—	○
		66.2	Encoder initial communication - Receive data error 2 (safety observation function)	DB	—	—	○
		66.3	Encoder initial communication - Receive data error 3 (safety observation function)	DB	—	—	○
		66.7	Encoder initial communication - Transmission data error 1 (safety observation function)	DB	—	—	○
		66.9	Encoder initial communication - Process error 1 (safety observation function)	DB	—	—	○
67	Encoder normal communication error 1 (safety observation function)	67.1	Encoder normal communication - Receive data error 1 (safety observation function)	DB	—	—	○
		67.2	Encoder normal communication - Receive data error 2 (safety observation function)	DB	—	—	○
		67.3	Encoder normal communication - Receive data error 3 (safety observation function)	DB	—	—	○
		67.4	Encoder normal communication - Receive data error 4 (safety observation function)	DB	—	—	○
		67.7	Encoder normal communication - Transmission data error 1 (safety observation function)	DB	—	—	○
68	STO diagnosis error	68.1	Mismatched STO signal error	DB	—	—	○
69	Command error	69.1	Forward rotation-side software limit detection - Command excess error	SD	○	○	○
		69.2	Reverse rotation-side software limit detection - Command excess error	SD	○	○	○
		69.3	Forward rotation stroke end detection - Command excess error	SD	○	○	○
		69.4	Reverse rotation stroke end detection - Command excess error	SD	○	○	○
		69.5	Upper stroke limit detection - Command excess error	SD	○	○	○
		69.6	Lower stroke limit detection - Command excess error	SD	○	○	○

Alarm		Details		Stop method *2 *3	Alarm deactivation		
No.	Name	No.	Name		Alarm reset	CPU reset	Power cycling
70	Load-side encoder initial communication error 1	70.1	Load-side encoder initial communication - Receive data error 1	DB	—	—	○
		70.2	Load-side encoder initial communication - Receive data error 2	DB	—	—	○
		70.3	Load-side encoder initial communication - Receive data error 3	DB	—	—	○
		70.4	Load-side encoder initial communication - Encoder malfunction *6	DB	—	—	○
		70.5	Load-side encoder initial communication - Transmission data error 1	DB	—	—	○
		70.6	Load-side encoder initial communication - Transmission data error 2	DB	—	—	○
		70.7	Load-side encoder initial communication - Transmission data error 3	DB	—	—	○
		70.8	Encoder initial communication - Incompatible encoder *6	DB	—	—	○
		70.A	Load-side encoder initial communication - Process error 1	DB	—	—	○
		70.B	Load-side encoder initial communication - Process error 2	DB	—	—	○
		70.C	Load-side encoder initial communication - Process error 3	DB	—	—	○
		70.D	Load-side encoder initial communication - Process error 4	DB	—	—	○
		70.E	Load-side encoder initial communication - Process error 5	DB	—	—	○
		70.F	Load-side encoder initial communication - Process error 6	DB	—	—	○
71	Load-side encoder normal communication error 1	71.1	Load-side encoder normal communication - Receive data error 1	EDB	—	—	○
		71.2	Load-side encoder normal communication - Receive data error 2	EDB	—	—	○
		71.3	Load-side encoder normal communication - Receive data error 3	EDB	—	—	○
		71.5	Load-side encoder normal communication - Transmission data error 1	EDB	—	—	○
		71.6	Load-side encoder normal communication - Transmission data error 2	EDB	—	—	○
		71.7	Load-side encoder normal communication - Transmission data error 3	EDB	—	—	○
		71.9	Load-side encoder normal communication - Receive data error 4	EDB	—	—	○
		71.A	Load-side encoder normal communication - Receive data error 5	EDB	—	—	○
72	Load-side encoder normal communication error 2	72.1	Load-side encoder data error 1	EDB	—	—	○
		72.2	Load-side encoder data update error	EDB	—	—	○
		72.3	Load-side encoder data waveform error	EDB	—	—	○
		72.4	Load-side encoder non-signal error	EDB	—	—	○
		72.5	Load-side encoder hardware error 1	EDB	—	—	○
		72.6	Load-side encoder hardware error 2	EDB	—	—	○
		72.9	Load-side encoder data error 2	EDB	—	—	○

Alarm		Details		Stop method ^{*2} ^{*3}	Alarm deactivation		
No.	Name	No.	Name		Alarm reset	CPU reset	Power cycling
74	Option card error 1	74.1	Option card error 1	DB	—	—	○
		74.2	Option card error 2	DB	—	—	○
		74.3	Option card error 3	DB	—	—	○
		74.4	Option card error 4	DB	—	—	○
		74.5	Option card error 5	DB	—	—	○
75	Option card error 2	75.3	Option card connection error	EDB	—	—	○
		75.4	Option card disconnected	DB	—	—	○
79	Functional safety unit diagnosis error	79.1	Functional safety unit power voltage error	DB	○ ^{*7}	—	○
		79.2	Functional safety unit internal error	DB	—	—	○
		79.3	Abnormal temperature of functional safety unit	SD	○ ^{*7}	—	○
		79.4	Servo amplifier error	SD	—	—	○
		79.5	Input device error	SD	—	—	○
		79.6	Output device error	SD	—	—	○
		79.7	Mismatched input signal error	SD	—	—	○
		79.8	Position feedback fixing error	DB	—	—	○
7A	Parameter setting error (safety observation function)	7A.1	Parameter verification error (safety observation function)	DB	—	—	○
		7A.2	Parameter setting range error (safety observation function)	DB	—	—	○
		7A.3	Parameter combination error (safety observation function)	DB	—	—	○
		7A.4	Functional safety unit combination error (safety observation function)	DB	—	—	○
7B	Encoder diagnosis error (safety observation function)	7B.1	Encoder diagnosis error 1 (safety observation function)	DB	—	—	○
		7B.2	Encoder diagnosis error 2 (safety observation function)	DB	—	—	○
		7B.3	Encoder diagnosis error 3 (safety observation function)	DB	—	—	○
		7B.4	Encoder diagnosis error 4 (safety observation function)	DB	—	—	○
7C	Functional safety unit communication diagnosis error (safety observation function)	7C.1	Functional safety unit communication setting error (safety observation function)	SD	○ ^{*7}	○	○
		7C.2	Functional safety unit communication data error (safety observation function)	SD	○ ^{*7}	○	○
7D	Safety observation error	7D.1	Stop observation error	DB	○ ^{*3}	—	○
		7D.2	Speed observation error	DB	○ ^{*7}	—	○
82	Master-slave operation error 1	82.1	Master-slave operation error 1	EDB	○	○	○
84	Network module initialization error	84.1	Network module undetected error	DB	—	—	○
		84.2	Network module initialization error 1	DB	—	—	○
		84.3	Network module initialization error 2	DB	—	—	○
85	Network module error	85.1	Network module error 1	SD	—	—	○
		85.2	Network module error 2	SD	—	—	○
		85.3	Network module error 3	SD	—	—	○
86	Network communication error	86.1	Network communication error 1	SD	○	—	○
		86.2	Network communication error 2	SD	○	—	○
		86.3	Network communication error 3	SD	○	—	○
		86.4	Network communication error 4	SD	○	—	○
8A	USB communication time-out error/ serial communication time-out error/ Modbus RTU communication time-out error	8A.1	USB communication time-out error/serial communication time-out error	SD	○	○	○
		8A.2	Modbus RTU communication time-out error	SD	○	○	○

Alarm		Details		Stop method ^{*2} ^{*3}	Alarm deactivation		
No.	Name	No.	Name		Alarm reset	CPU reset	Power cycling
8D	CC-Link IE communication error	8D.1	CC-Link IE communication error 1	SD	○	—	○
		8D.2	CC-Link IE communication error 2	SD	○	—	○
		8D.3	Master station setting error 1	DB	○	—	○
		8D.5	Master station setting error 2	DB	—	—	○
		8D.6	CC-Link IE communication error 3	SD	○	—	○
		8D.7	CC-Link IE communication error 4	SD	○	—	○
		8D.8	CC-Link IE communication error 5	SD	○	—	○
		8D.9	Synchronization error 1	SD	—	—	○
		8D.A	Synchronization error 2	SD	—	—	○
8E	USB communication error/Serial communication error/Modbus RTU communication error	8E.1	USB communication receive error/serial communication receive error	SD	○	○	○
		8E.2	USB communication checksum error/serial communication checksum error	SD	○	○	○
		8E.3	USB communication character error/serial communication character error	SD	○	○	○
		8E.4	USB communication command error/serial communication command error	SD	○	○	○
		8E.5	USB communication data number error/serial communication data number error	SD	○	○	○
		8E.6	Modbus RTU communication receive error	SD	○	○	○
		8E.7	Modbus RTU communication message frame error	SD	○	○	○
		8E.8	Modbus RTU communication CRC error	SD	○	○	○
88888	Watchdog	8888_	Watchdog	DB	—	—	○

*1 After resolving the source of trouble, cool the equipment for approximately 30 minutes.

*2 The following shows three stop methods of DB, EDB, and SD.

DB: Dynamic brake stop (For a servo amplifier without the dynamic brake, the servo motor coasts.)

Coasts for MR-J4-03A6(-RJ) and MR-J4W2-0303B6. Note that EDB is applied when an alarm below occurs;

[AL. 30.1], [AL. 32.2], [AL. 32.4], [AL. 51.1], [AL. 51.2], [AL. 888]

SD: Forced stop deceleration

EDB: Electronic dynamic brake stop (available with specified servo motors only)

Refer to the following table for the specified servo motors. For other than the specified servo motors, the stop method of DB is applied.

series	Servo motor
HG-KR	HG-KR053/HG-KR13/HG-KR23/HG-KR43
HG-MR	HG-MR053/HG-MR13/HG-MR23/HG-MR43
HG-SR	HG-SR51/HG-SR52
HG-AK	HG-AK0136/HG-AK0236/HG-AK0336

*3 This is applicable when [Pr. PA04] is set to the initial value. The stop method of SD can be changed to DB with [Pr. PA04].

*4 The alarm can be canceled with the following settings:

When the fully closed loop control mode is selected: Set [Pr. PE03] to "1 _ _ _".

When a linear servo motor or a direct drive motor is used: Set [Pr. PL04] to "1 _ _ _".

*5 In some controller communication status, the alarm factor may not be removed.

*6 This alarm occurs only in the J3 compatibility mode.

*7 Reset alarms while all the safety observation functions have stopped.

Warning list

Warning		Details		Stop method
No.	Name	No.	Name	*2 *3
90	Home position return incomplete warning	90.1	Home position return incomplete	—
		90.2	Home position return abnormal termination	—
		90.5	Z-phase unpassed	—
91	Servo amplifier overheat warning *1	91.1	Main circuit device overheat warning	—
92	Battery cable disconnection warning	92.1	Encoder battery cable disconnection warning	—
		92.3	Battery degradation	—
93	ABS data transfer warning	93.1	Magnetic pole detection incomplete warning at ABS data transfer request	—
95	STO warning	95.1	STO1 off detection	DB
		95.2	STO2 off detection	DB
		95.3	STO warning 1 (safety observation function)	DB
		95.4	STO warning 2 (safety observation function)	DB
		95.5	STO warning 3 (safety observation function)	DB
96	Home position setting warning	96.1	In-position warning at home positioning	—
		96.2	Command input warning at home positioning	—
		96.3	Servo off warning at home positioning	—
		96.4	Magnetic pole detection incomplete warning at home positioning	—
97	Positioning specification warning	97.1	Program operation disabled warning	—
		97.2	Next station position warning	—
98	Software limit warning	98.1	Forward rotation-side software stroke limit reached	—
		98.2	Reverse rotation-side software stroke limit reached	—
99	Stroke limit warning	99.1	Forward rotation stroke end off	*4 *5
		99.2	Reverse rotation stroke end off	*4 *5
		99.4	Upper stroke limit off	*5
		99.5	Lower stroke limit off	*5
9A	Optional unit input data error warning	9A.1	Optional unit input data sign error	—
		9A.2	Optional unit BCD input data error	—
9B	Error excessive warning	9B.1	Excess droop pulse 1 warning	—
		9B.3	Excess droop pulse 2 warning	—
		9B.4	Error excessive warning during 0 torque limit	—
9C	Converter warning	9C.1	Converter unit warning	—
9D	CC-Link IE warning 1	9D.1	Station number switch change warning	—
		9D.2	Master station setting warning	—
		9D.3	Overlapping station number warning	—
		9D.4	Mismatched station number warning	—
9E	CC-Link IE warning 2	9E.1	CC-Link IE communication warning	—
9F	Battery warning	9F.1	Low battery	—
		9F.2	Battery degradation warning	—
E0	Excessive regeneration warning	E0.1	Excessive regeneration warning	—
E1	Overload warning 1	E1.1	Thermal overload warning 1 during operation	—
		E1.2	Thermal overload warning 2 during operation	—
		E1.3	Thermal overload warning 3 during operation	—
		E1.4	Thermal overload warning 4 during operation	—
		E1.5	Thermal overload warning 1 during a stop	—
		E1.6	Thermal overload warning 2 during a stop	—
		E1.7	Thermal overload warning 3 during a stop	—
		E1.8	Thermal overload warning 4 during a stop	—
E2	Servo motor overheat warning	E2.1	Servo motor temperature warning	—

Warning		Details		Stop method *2 *3
No.	Name	No.	Name	
E3	Absolute position counter warning	E3.1	Multi-revolution counter travel distance excess warning	—
		E3.2	Absolute position counter warning	—
		E3.4	Absolute positioning counter EEPROM writing frequency warning	—
		E3.5	Encoder absolute positioning counter warning	—
E4	Parameter warning	E4.1	Parameter setting range error warning	—
E5	ABS time-out warning	E5.1	Time-out during ABS data transfer	—
		E5.2	ABSM off during ABS data transfer	—
		E5.3	SON off during ABS data transfer	—
E6	Servo forced stop warning	E6.1	Forced stop warning	SD
		E6.2	SS1 forced stop warning 1 (safety observation function)	SD
		E6.3	SS1 forced stop warning 2 (safety observation function)	SD
E7	Controller forced stop warning	E7.1	Controller forced stop input warning	SD
E8	Cooling fan speed reduction warning	E8.1	Decreased cooling fan speed warning	—
		E8.2	Cooling fan stop	—
E9	Main circuit off warning	E9.1	Servo-on signal on during main circuit off	DB
		E9.2	Bus voltage drop during low speed operation	DB
		E9.3	Ready-on signal on during main circuit off	DB
		E9.4	Converter unit forced stop	DB
EA	ABS servo-on warning	EA.1	ABS servo-on warning	—
EB	The other axis error warning	EB.1	The other axis error warning	DB
EC	Overload warning 2	EC.1	Overload warning 2	—
ED	Output watt excess warning	ED.1	Output watt excess warning	—
F0	Tough drive warning	F0.1	Instantaneous power failure tough drive warning	—
		F0.3	Vibration tough drive warning	—
F2	Drive recorder - Miswriting warning	F2.1	Drive recorder - Area writing time-out warning	—
		F2.2	Drive recorder - Data miswriting warning	—
F3	Oscillation detection warning	F3.1	Oscillation detection warning	—
F4	Positioning warning	F4.4	Target position setting range error warning	—
		F4.6	Acceleration time constant setting range error warning	—
		F4.7	Deceleration time constant setting range error warning	—
		F4.9	Home position return type error warning	—
F5	Simple cam function - Cam data miswriting warning	F5.1	Cam data - Area writing time-out warning	—
		F5.2	Cam data - Area miswriting warning	—
		F5.3	Cam data checksum error	—
F6	Simple cam function - Cam control warning	F6.1	Cam axis current value per cycle restoration failed	—
		F6.2	Cam axis feed current value restoration failed	—
		F6.3	Cam unregistered error	—
		F6.4	Cam control data setting range error	—
		F6.5	Cam No. external error	—
		F6.6	Cam control inactive	—
F7	Machine diagnosis warning	F7.1	Vibration failure prediction warning	—
		F7.2	Friction failure prediction warning	—
		F7.3	Total travel distance failure prediction warning	—

*1 After resolving the source of trouble, cool the equipment for approximately 30 minutes.

*2 The following shows two stop methods of DB and SD.

DB: Dynamic brake stop (For a servo amplifier without the dynamic brake, the servo motor coasts.)

Coasts for MR-J4-03A6(-RJ) and MR-J4W2-0303B6.

SD: Forced stop deceleration

*3 This is applicable when [Pr. PA04] is set to the initial value. The stop system of SD can be changed to DB using [Pr. PA04].

*4 For MR-J4-_A_ servo amplifier, quick stop or slow stop can be selected with [Pr. PD30].

*5 For MR-J4-_GF_ servo amplifier, quick stop or slow stop can be selected with [Pr. PD12]. (I/O mode only)

7 CHARACTERISTICS

The following items are the same as those for MR-J4-_B_(-RJ). Refer to the section of the detailed explanation field for details. "MR-J4-_B_" means "MR-J4-_B_(-RJ) Servo Amplifier Instruction Manual".

Item	Detailed explanation
Cable bending life	MR-J4-_B_ section 10.4

7.1 Overload protection characteristics

Point

This section describes MR-J4-DU_B4-RJ100 drive units only. MR-CV55K4 power regeneration converter units, refer to section 3.5 in "MR-CV_/MR-CR55K_/MR-J4-DU_(-RJ) Instruction Manual".

An electronic thermal is built in the drive unit to protect the servo motor, drive unit, and servo motor power wires from overloads. [AL. 50 Overload 1] occurs if overload operation performed is above the electronic thermal protection curve shown in the following figure. [AL. 51 Overload 2] occurs if the maximum current is applied continuously for several seconds due to machine collision, etc. Use the equipment on the left-side area of the continuous or broken line in the graph.

For the system where the unbalanced torque occurs, such as a vertical axis, it is recommended that the unbalanced torque of the machine be kept at 70% or lower of the motor's rated torque.

The drive unit has the servo motor overload protective function. (The servo motor overload current (full load current) is set on the basis of 120% rated current of the drive unit.)

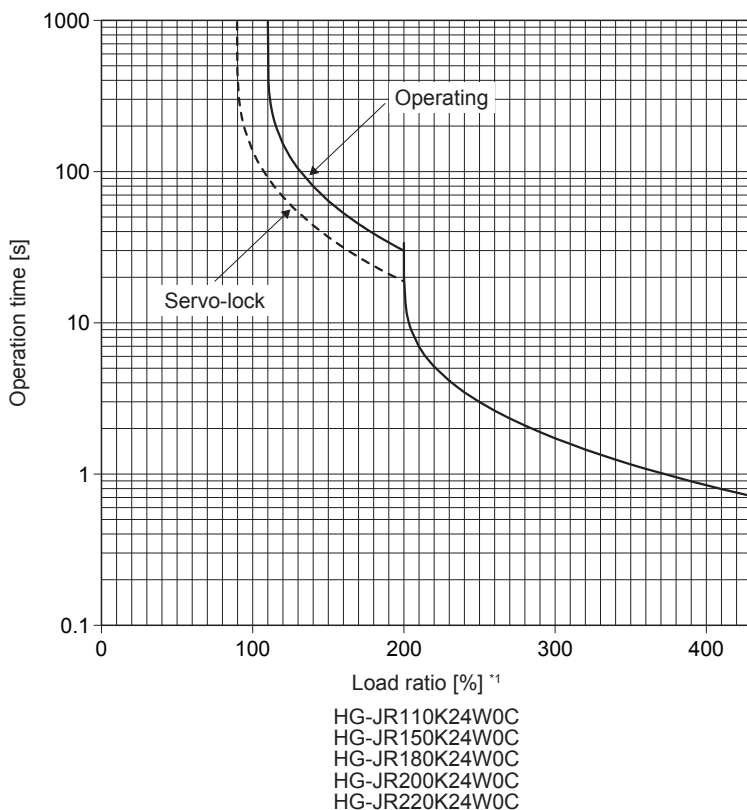

*1 This graph shows electronic thermal protection characteristics for a load ratio of up to 456%. For the maximum load ratio, refer to maximum currents in "Servo Motor Instruction Manual (Vol. 3)".

7.2 Power supply capacity and generated loss

Generated heat of the power regeneration converter unit and drive unit

The following tables indicate the generated loss under rated load and the power supply capacity per combination of the power regeneration converter unit and drive unit.

Power regeneration converter unit	Power supply capacity [kVA]	Generated heat of power regeneration converter unit [W]			Area required for heat dissipation [m ²]
		At rated output	At rated output [Generated heat in the cabinet when cooled outside the cabinet]	With servo-off	
MR-CV55K4	78	596	164	30	12.0

Drive unit	Generated heat of drive unit [W]			Area required for heat dissipation [m ²]
	At rated output	At rated output [Generated heat in the cabinet when cooled outside the cabinet]	With servo-off	
MR-J4-DU45KB4-RJ100	1110	216	30	22.2
MR-J4-DU55KB4-RJ100	1440	216	30	28.8

The power supply capacity and generated heat for parallel drive systems are obtained by multiplying the listed values by the number of sets of combined power regeneration converter units and drive units required to drive a servo motor. The power supply capacity will be lower than the listed values when the output wattage of the servo motor driven by the drive unit connected to the power regeneration converter unit is lower than the converter capacity.

The servo motor requires 2 times to 3 times greater instantaneous power for acceleration, and therefore, use the power supply which ensures that the voltage lies within the permissible voltage fluctuation at the main circuit power supply terminals (L1/L2/L3) of the power regeneration converter unit. The power supply capacity will vary according to the power supply impedance.

The actual generated heat falls within the ranges at rated output and at servo-off according to the frequencies of use during operation. When designing an enclosed cabinet, use the values in the table, considering the worst operating conditions.

Heat dissipation area for an enclosed type cabinet

The enclosed type cabinet (hereafter called the cabinet) which will contain the power regeneration converter unit and drive unit should be designed to ensure that its temperature rise is within +10 °C at the ambient temperature of 40 °C. Calculate the necessary cabinet dissipation area (allowing a margin of approximately 5 °C for the ambient temperature of 55 °C maximum) with the following equation.

$$A = \frac{P}{K \cdot \Delta T}$$

- A: Heat dissipation area [m²]
P: Loss generated in the cabinet [W]
 ΔT : Difference between internal and ambient temperatures [°C]
K: Heat dissipation coefficient [5 to 6]

When calculating the heat dissipation area with the equation, assume that P is the sum of all losses generated in the cabinet. Refer to the following for the generated heat of the power regeneration converter unit and drive unit.

☞ Page 56 Generated heat of the power regeneration converter unit and drive unit

"A" indicates the effective area for heat dissipation, but if the cabinet is directly installed on an insulated wall, that extra amount must be added to the cabinet's surface area. The required heat dissipation area will vary with the conditions in the cabinet. If convection in the cabinet is poor and heat builds up, effective heat dissipation will not be possible. Therefore, arrangement of the equipment in the cabinet and the use of a cooling fan should be considered. The following lists the cabinet dissipation area (guideline) when the converter unit and drive unit are operated at the ambient temperature of 40 °C under rated load.

☞ Page 56 Generated heat of the power regeneration converter unit and drive unit

When air flows along the outer wall of the cabinet, effective heat exchange will be possible, because the temperature slope inside and outside the cabinet will be steeper.

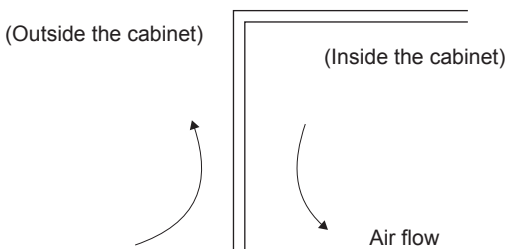

7.3 Dynamic brake characteristics

⚠ CAUTION

- The coasting distance is a theoretically calculated value which ignores the running load such as friction. The calculated value will be longer than the actual distance. If an enough braking distance is not provided, a moving part may crash into the stroke end, which is very dangerous. Install the anti-crash mechanism such as an air brake or an electric/mechanical stopper such as a shock absorber to reduce the shock of moving parts.

Point

Do not use dynamic brake to stop in a normal operation as it is the function to stop in emergency. For a machine operating at the recommended load to motor inertia ratio or less, the estimated number of usage times of the dynamic brake is 1000 times while the machine decelerates from the rated speed to a stop once in 10 minutes. Be sure to enable EM1 (Forced stop 1) after servo motor stops when using EM1 frequently in other than emergency.

Calculation of coasting distance

The following figure shows the pattern in which the servo motor comes to a stop when the dynamic brake is operated.

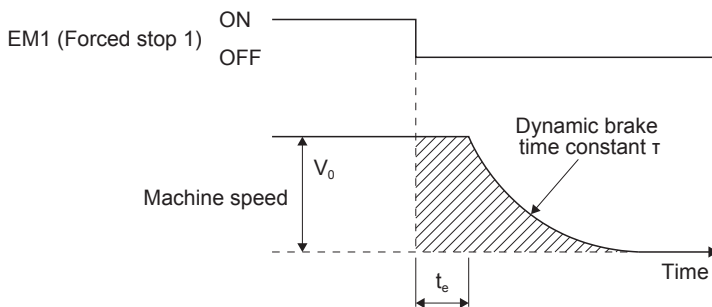

Use the following equation to calculate an approximate coasting distance to a stop.

$$L_{max} = \frac{V_0}{60} \cdot \left\{ t_e + \tau \left(1 + \frac{J_L}{J_M} \right) \right\}$$

L_{max} : Maximum coasting distance [mm]

V_0 : Machine's fast feed speed [mm/min]

J_M : Moment of inertia of the servo motor [$\times 10^{-4}$ kg·m²]

J_L : Load moment of inertia converted into equivalent value on servo motor shaft [$\times 10^{-4}$ kg·m²]

τ : Dynamic brake time constant [s]

t_e : Delay time of control section [s]

There are delays caused by multiple drive units being in the process of stopping the servo motor with the dynamic brake, by a magnetic contactor built into the external dynamic brake (about 100 ms in total), and by external relays.

The dynamic brake time constant τ varies with the servo motor and machine operation speeds.

☞ Page 59 Dynamic brake time constant

A working part generally has a friction force. Therefore, actual coasting distance will be shorter than a maximum coasting distance calculated with the following equation. Page 59 Dynamic brake time constant

Dynamic brake time constant

The following shows dynamic brake time constant τ .

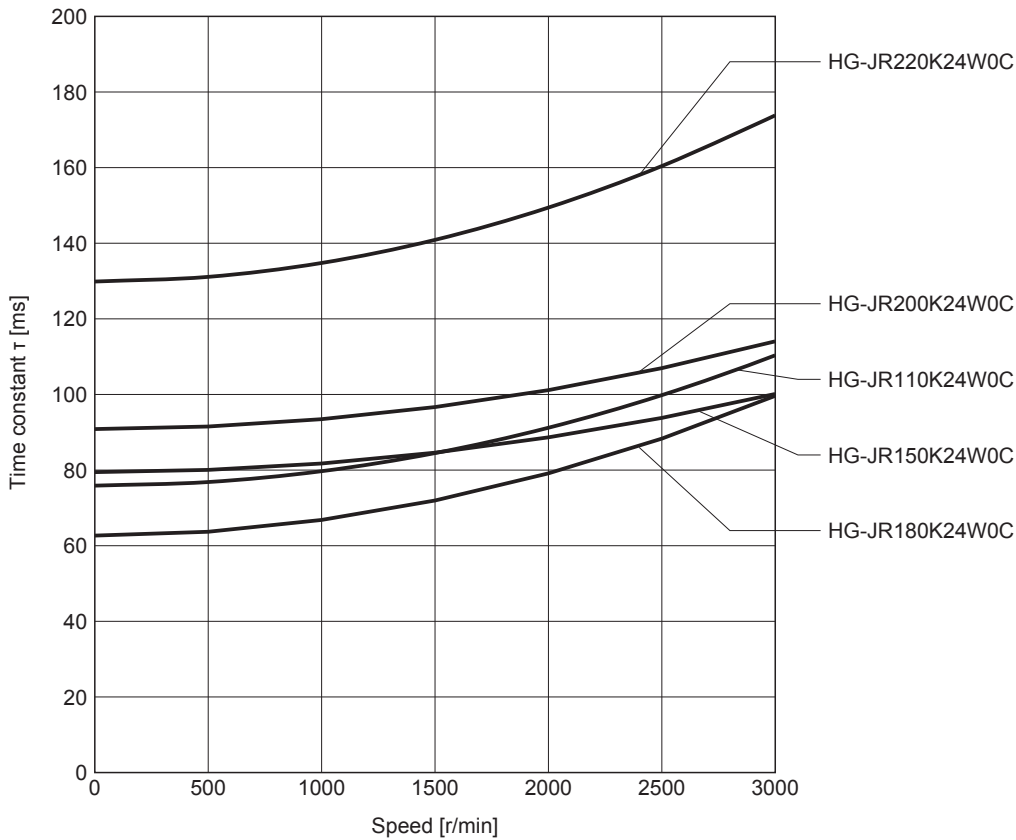

Permissible load to motor inertia when the dynamic brake is used

Use the dynamic brake under the load to motor inertia ratio indicated in the following table. If the ratio is higher than this value, the dynamic brake may burn. If there is a possibility that the ratio may exceed the value, contact your local sales office.

The values of the permissible load to motor inertia ratio in the table are the values at the maximum rotation speed of the servo motor.

Servo motor	Load to motor inertia ratio
HG-JR110K24W0C	10
HG-JR150K24W0C	10
HG-JR180K24W0C	10
HG-JR200K24W0C	10
HG-JR220K24W0C	10

7.4 Inrush currents at power-on of main circuit/control circuit

Since large inrush currents flow in the power supplies, be sure to use molded-case circuit breakers and magnetic contactors. (Refer to section 8.5 in "MR-CV_/MR-CR55K_/MR-J4-DU_(-RJ) Instruction Manual".)

Be sure to install a molded-case circuit breaker and a magnetic contactor for each combination of the power regeneration converter unit and drive unit. When circuit protectors are used, it is recommended that the inertia delay type, which is not tripped by an inrush current, be used.

Inrush currents of the power regeneration converter

The following shows the inrush current (reference data) that will flow when 480 V AC is applied.

Power regeneration converter unit	Inrush current (A0-P)	
	Main circuit power supply (L1/L2/L3)	Control circuit power supply (L11/L21)
MR-CV55K4	42 A (attenuated to approx. 20 A in 66 ms)	15 A (attenuated to approx. 2 A in 7 ms)

Inrush current of the drive unit

The following shows the inrush current (reference data) that will flow when 480 V AC is applied.

Drive unit	Inrush current (A0-P)
	Control circuit power supply (L11/L21)
MR-J4-DU45KB4-RJ100 MR-J4-DU55KB4-RJ100	27 A (attenuated to approx. 2 A in 45 ms)

8 OPTIONS AND PERIPHERAL EQUIPMENT

WARNING

- Before connecting any option or peripheral equipment, turn off the power and wait for 20 minutes or more until the charge lamp turns off. Then, confirm that the voltage between L+ and L- is safe with a voltage tester and others. Otherwise, an electric shock may occur. In addition, when confirming whether the charge lamp is off or not, always confirm it from the front of the converter unit.

CAUTION

- Use the specified peripheral equipment and options to prevent a malfunction or a fire.

Point

We recommend using HIV wires to wire the converter units, drive units, options, and peripheral equipment. Therefore, the recommended wire sizes may be different from those of the wires used for the previous converter units, drive units and others.

The following items are the same as those for MR-J4-_B_(-RJ). Refer to the section of the detailed explanation field for details. "MR-J4-_B_" means "MR-J4-_B_(-RJ) Servo Amplifier Instruction Manual". "MR-J4-DU_B_" means "MR-CV_/MR-CR55K_/MR-J4-DU_(-RJ) Instruction Manual".

Item	Detailed explanation
Cable/connector sets	MR-J4-DU_B_ section 8.1
Junction terminal block PS7DW-20V14B-F (recommended)	MR-J4-_B_ section 11.6
Battery *1	MR-J4-_B_ section 11.8
Selection example of wires	MR-J4-DU_B_ section 8.4
Molded-case circuit breakers, fuses, magnetic contactors	MR-J4-DU_B_ section 8.5
Relay (recommended)	MR-J4-_B_ section 11.13
Noise reduction techniques	MR-J4-DU_B_ section 8.8
Earth-leakage current breaker	MR-J4-DU_B_ section 8.9
EMC filter (recommended)	MR-J4-DU_B_ section 8.10
MR-DCBAR_ bus bar	MR-J4-DU_B_ section 8.12

*1 For absolute position detection systems, connect an optional battery to only the drive unit of the encoder master servo amplifier. Do not connect the optional battery to the drive units of the encoder slave servo amplifiers.

8.1 MR Configurator2

Point

The MR-J4-DU_B4-RJ100 drive unit can be used with MR Configurator2 with software version 1.60N or later.

This section provides descriptions specific to the parallel drive system. For other details, refer to section 11.7 in "MR-J4-_B_(-RJ) Servo Amplifier Instruction Manual".

Restrictions

For parallel drive systems, the following functions are unavailable.

Item	Description
Test operation	Jog mode, positioning mode, motor-less operation, DO forced output, and program operation, test mode information
Adjustment	One-touch tuning and machine analyzer

Using the parallel drive system

To use the parallel drive system, the model name of a servo amplifier must be registered in MR Configurator2. Register the model name in the following procedure.

1. Start MR Configurator2, click "Tools" in the menu bar, and then click "Update Parameter Setting Range".

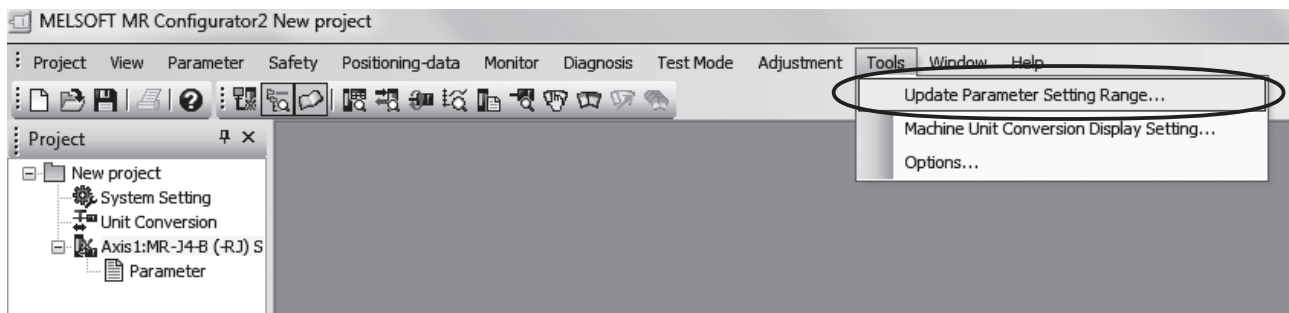

2. Select "Register a new model from a file.", and click "Next" in "Update Parameter Setting Range" window.

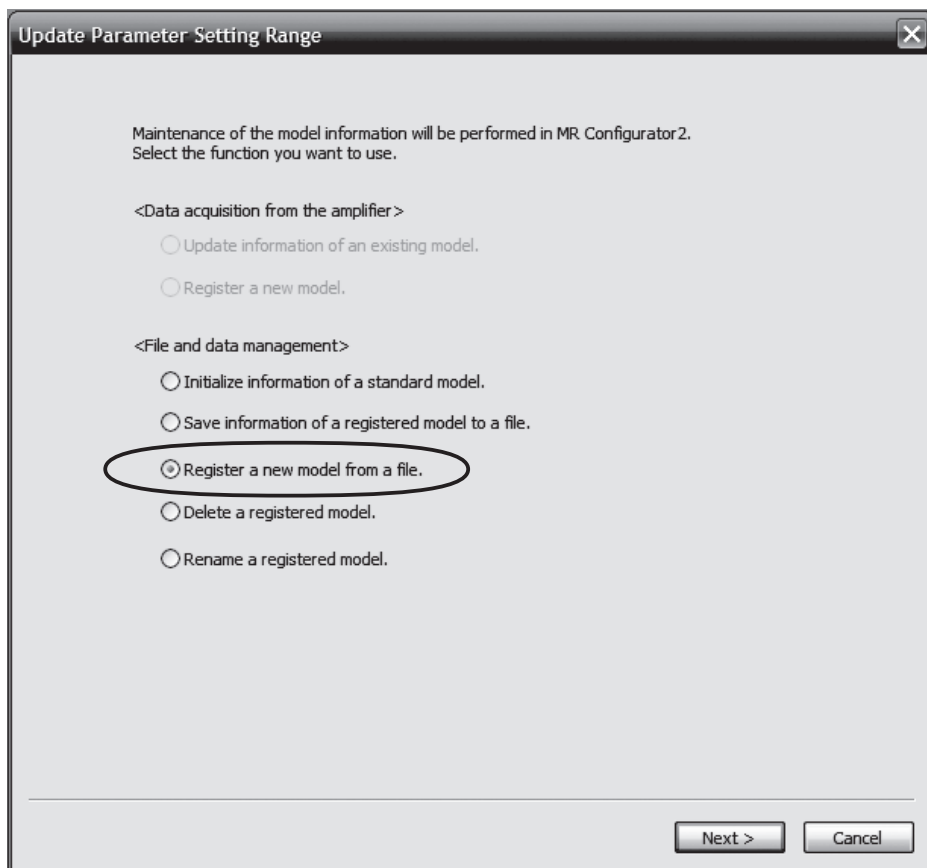

3. Click "Browse".

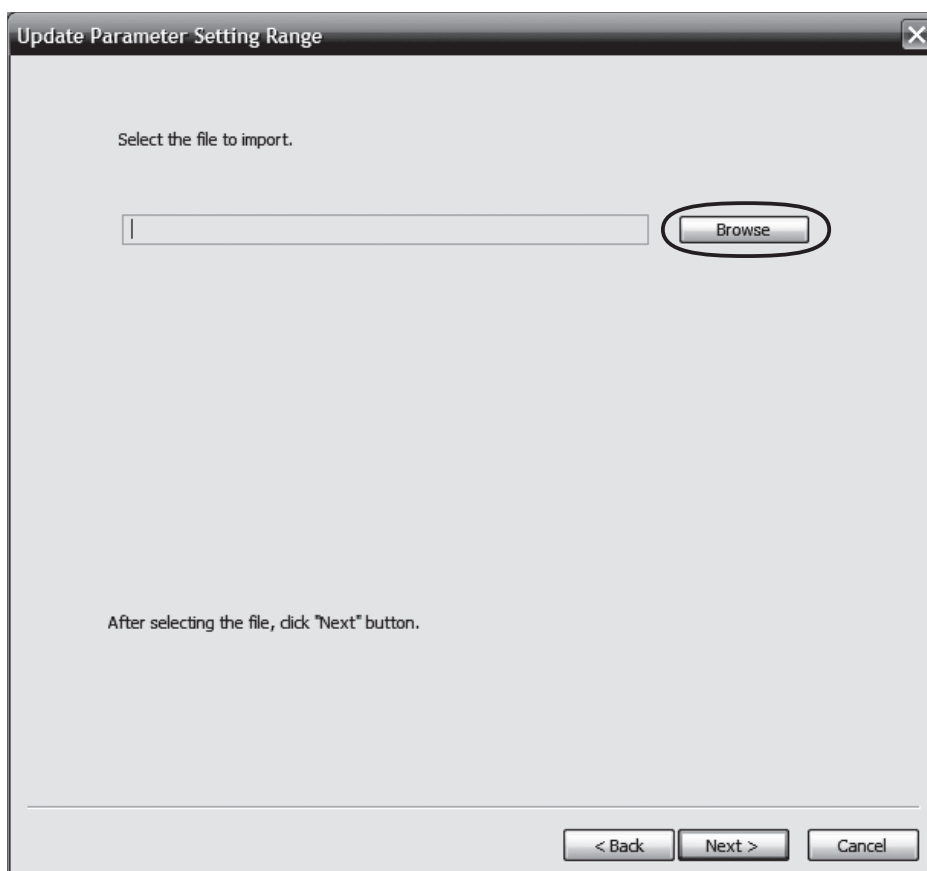

4. Select "J4B-S100_en.rng" stored in "C:\Melservo\MR2\mfr\en", and click "Open" in "Open File" window.

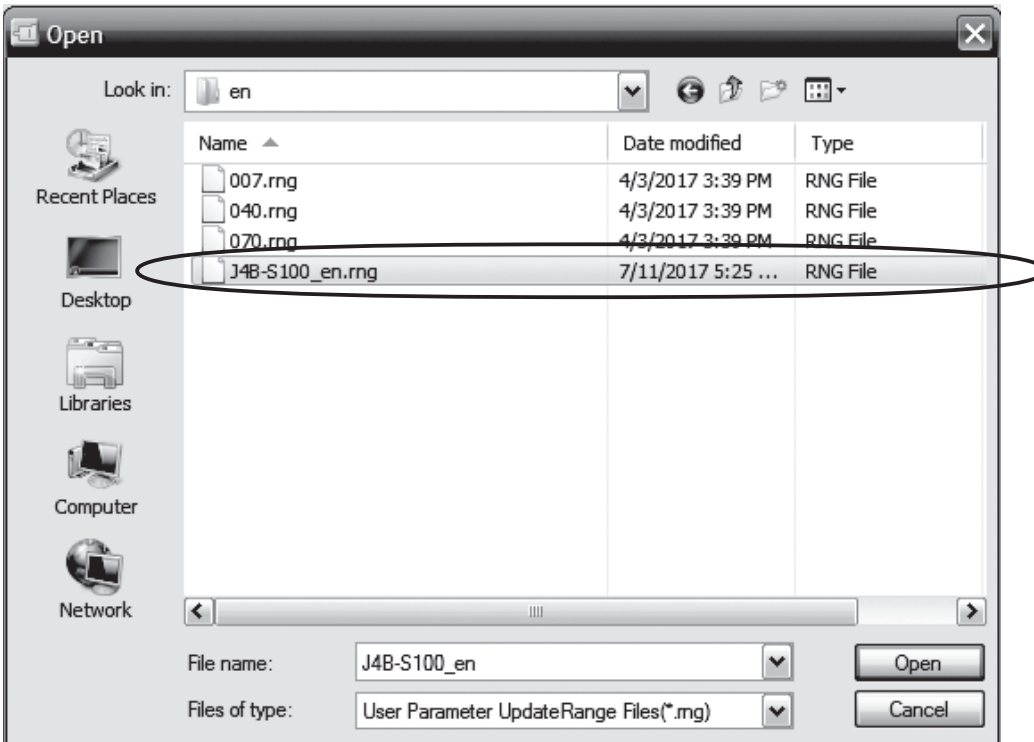

5. Check that "J4B-S100_en.rng" is selected, and click "Next" in "Update Parameter Setting Range" window.

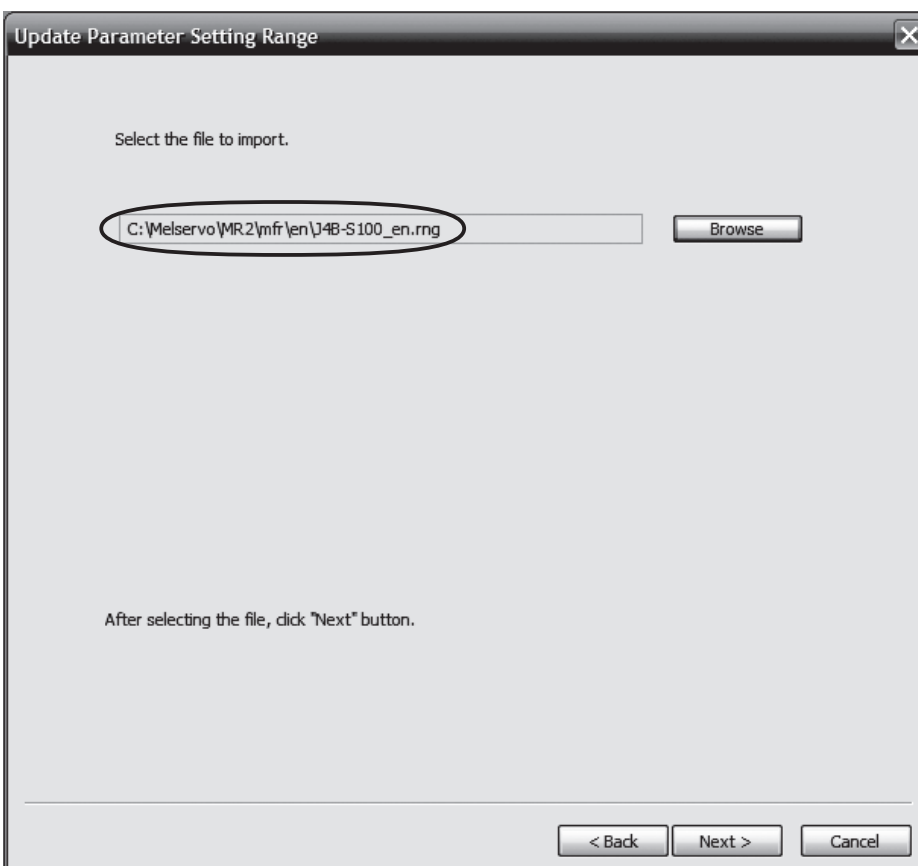

6. Check that reading has been completed without error, and click "Save".

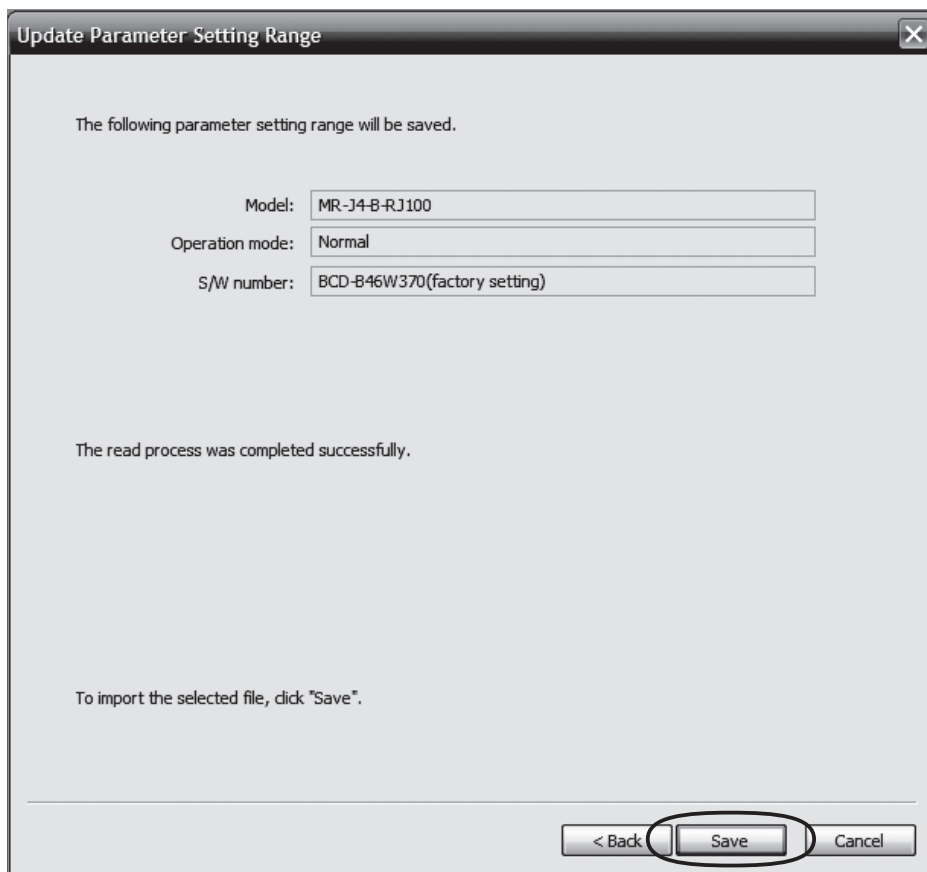

7. The model name of the servo amplifier has been registered. Click "End".



How to select the model name of the servo amplifier registered

When creating a project, select "MR-J4-B-RJ100" in "Model".

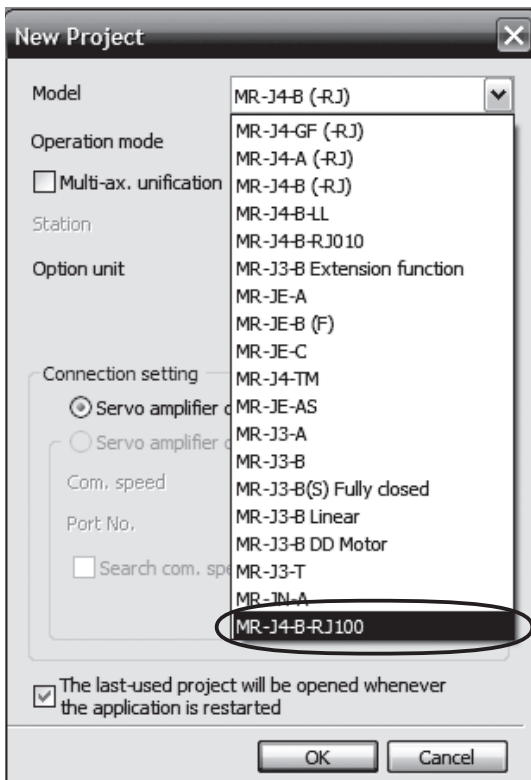

8.2 AC reactor

Always connect one AC reactor to one power regeneration converter unit.

The AC reactor generates heat of 100 °C higher than the ambient temperature. Fully consider heat dissipation, installation position, wires used, etc., before installing the AC reactor.

Magnetism generated from the AC reactor may affect other devices. Leave a clearance of 100 mm or more around wires so that they do not contact the AC reactor.

Specifications

Model		MR-AL-55K4-L		
Rated capacity [kW]		55		
Rated voltage		380 V AC to 480 V AC (power fluctuation ratio: within ±10%)		
Rated current [A]		106		
Frequency		50 Hz/60 Hz (frequency fluctuation: within ±3%)		
Environment	Ambient temperature	Operation	0 °C to 55 °C (non-freezing)	
		Storage	-20 °C to 65 °C (non-freezing)	
	Ambient humidity	Operation	5 %RH to 90 %RH (non-condensing)	
		Storage		
	Ambience		Indoors (no direct sunlight), no corrosive gas, inflammable gas, oil mist, dust, or conductive particle	
	Altitude		2000 m or less above sea level	
Vibration resistance		5.9 m/s ² or less		
Loss [W]		330		
Mass [kg]		56		

DIMENSIONS

[Unit: mm]

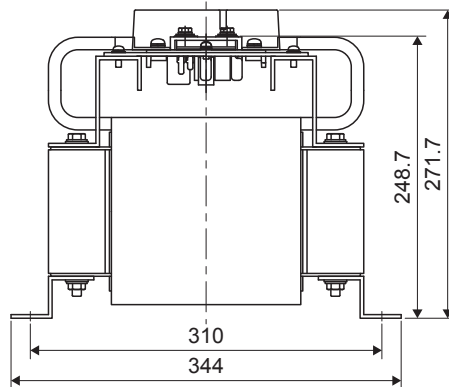
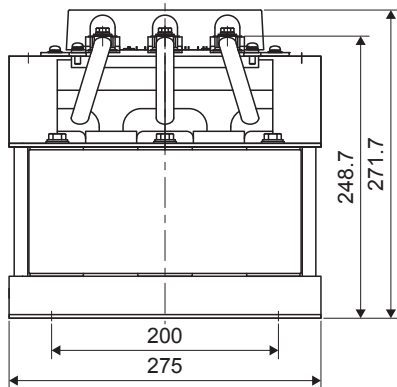
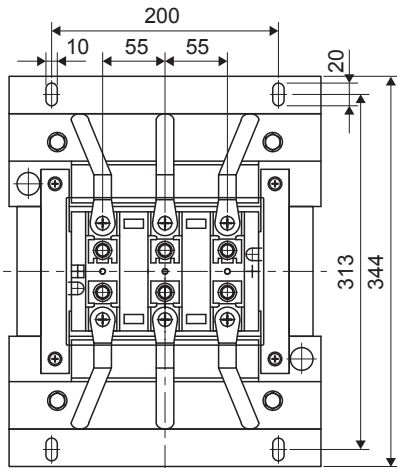

Mounting screw size: M8
Mass: 56 [kg]

8.3 External dynamic brake

CAUTION

- Use an external dynamic brake for this drive unit. Failure to do so will cause an accident because the servo motor does not stop immediately but coasts at an alarm occurrence for which the servo motor does not decelerate to stop. Ensure the safety in the entire equipment. For alarms for which the servo motor does not decelerate to stop, refer to the following.

 Page 41 TROUBLESHOOTING

Point

For drive units, EM2 has the same function as EM1 in the torque control mode.

Configure a sequence which switches off the magnetic contactor of the external dynamic brake after (or as soon as) servo-on command has been turned off at a power failure or a malfunction.

For the braking time taken when the external dynamic brake is operated, refer to the following.

 Page 58 Dynamic brake characteristics

The external dynamic brake is rated for a short duration. Do not use it very frequently.

The specifications of the input power supply for external dynamic brake are the same as those of the converter unit control circuit power supply.

When an alarm, [AL. E6 Servo forced stop warning], or [AL. E7 Controller forced stop warning] occurs, or the power is turned off, the external dynamic brake will operate. Do not use external dynamic brake to stop in a normal operation as it is the function to stop in emergency.

For a machine operating at the recommended load to motor inertia ratio or less, the estimated number of usage times of the external dynamic brake is 1000 times while the machine decelerates from the rated speed to a stop once in 10 minutes.

Be sure to enable EM1 (Forced stop 1) after servo motor stops when using EM1 frequently in other than emergency.

Specifications

Model		DBU-P55K-4-B		
Rated capacity [kW]		55		
Rated voltage		380 V AC to 480 V AC, power fluctuation $\pm 10\%$ or less		
Frequency		50 Hz/60 Hz, frequency fluctuation $\pm 3\%$ or less		
Load to motor inertia ratio		15 times or less		
Environment	Ambient temperature	Operation	0 °C to 55 °C (non-freezing)	
		Storage	-10 °C to 65 °C (non-freezing)	
	Ambient humidity	Operation	5 %RH to 90 %RH (non-condensing)	
		Storage		
	Ambience		Indoors (no direct sunlight), no corrosive gas, inflammable gas, oil mist, dust, or conductive particle	
	Altitude		2000 m or less above sea level	
Vibration resistance		5.9 m/s ² or less		
Mass [kg]		25		

Connection example

Use the following wires to connect the dynamic brake.

External dynamic brake	Wire [mm ²] ^{*1}	
	U/V/W	Except U/V/W
DBU-P55K-4-B	14 (AWG 6)	2 (AWG 14)

*1 Selection conditions of wire size are as follows.

Wire type: 600 V Grade heat-resistant polyvinyl chloride insulated wire (HIV wire)

Construction condition: Single wire set in midair

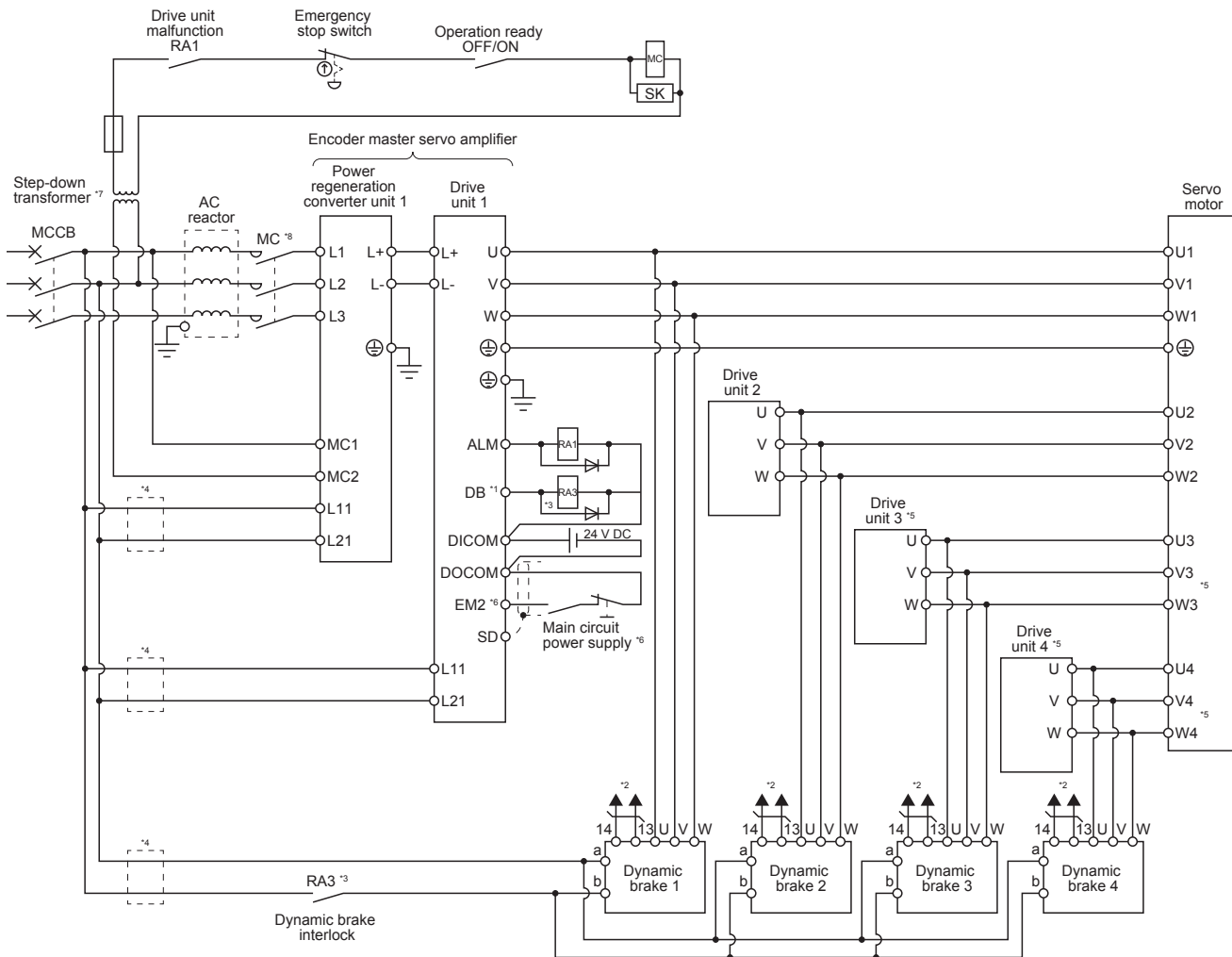

*1 Assign DB (Dynamic brake interlock) in [Pr. PD07] to [Pr. PD09].

*2 Terminals 13 and 14 are normally open contact outputs. If the dynamic brake is seized, terminals 13 and 14 will open. Therefore, configure an external sequence to prevent servo-on.

*3 The dynamic brake must be controlled by the drive unit of the encoder master servo amplifier.

*4 If the wire size used for the branch circuit is smaller than that used for L1, L2, and L3, install an overcurrent protection device (molded-case circuit breaker, fuse, or others) to protect the circuit.

*5 This is for connecting four drive units and four power regeneration converter units to the servo motor.

*6 To prevent an unexpected restart of the drive unit, configure a circuit to turn off EM2 (Forced stop 2) when the main circuit power is turned off.

*7 A step-down transformer is required when the coil voltage of the magnetic contactor is 200 V class.

*8 Depending on the main circuit voltage and operation pattern, bus voltage decreases, and that may cause the forced stop deceleration to shift to the dynamic brake deceleration. When dynamic brake deceleration is not required, delay the time to turn off the magnetic contactor.

DIMENSIONS

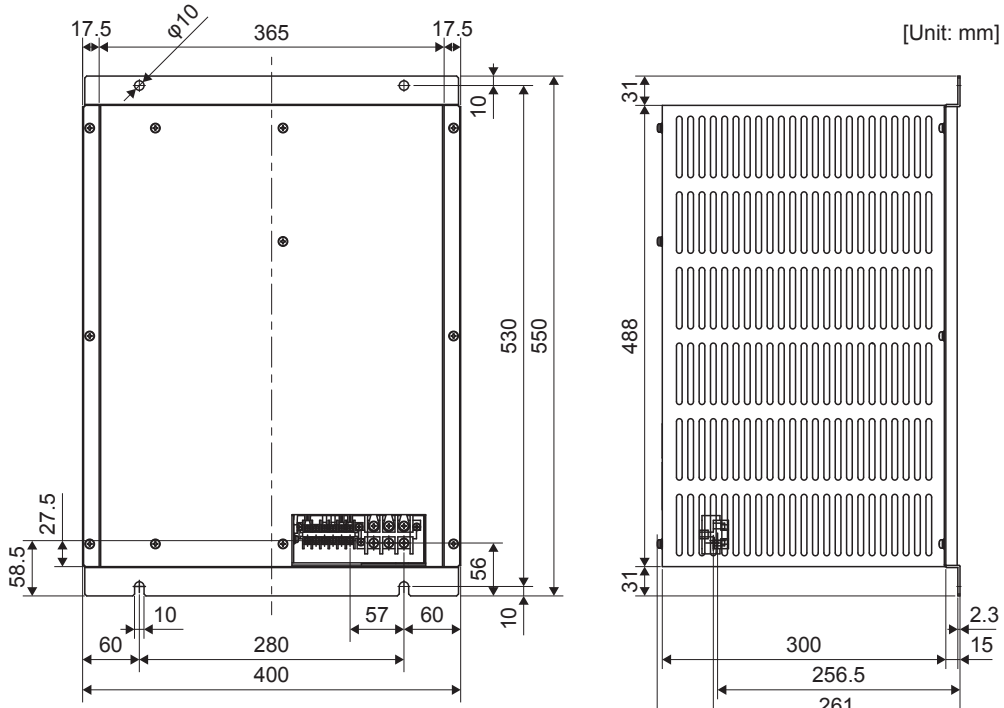

Terminal block

TE1

⊕	/	a	b	13	14
---	---	---	---	----	----

Screw size: M3.5

TE2

U	V	W
---	---	---

Screw size: M5

Mounting screw size: M8
Mass: 25 [kg]

9 USING STO FUNCTION

Point

For items other than the ones described in this chapter, refer to chapter 13 in "MR-J4-_B_(-RJ) Servo Amplifier Instruction Manual".

Wiring example

In the parallel drive system, multiple drive units drive one servo motor. Wire the STO signal to all the drive units.

The following shows a system that drives a servo motor with four MR-J4-DU_B4-RJ100 drive units and four MR-CV_ power regeneration converter units connected. For the number of drive units required to be connected to one servo motor, refer to the following.

☞ Page 13 Combinations of power regeneration converter units, drive units, and servo motors

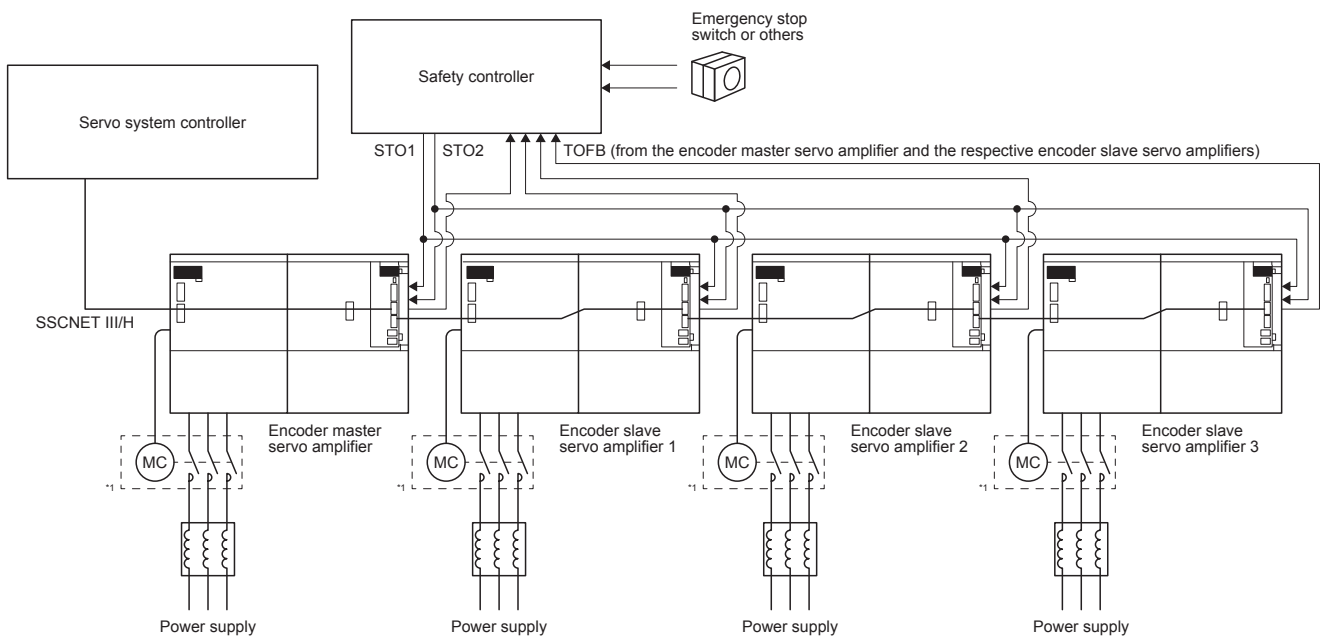

*1 For parallel drive systems, the magnetic contactor turns off when STO is inputted (when [AL. 95] has occurred). The setting of [Pr. PF07 Magnetic contactor shut-off selection at STO input (_ x _)] is invalid.

10 APPLICATION OF FUNCTIONS

The following items are the same as those for MR-J4-_B_(-RJ). Refer to the section of the detailed explanation field for details. "MR-J4-_B_" means "MR-J4-_B_(-RJ) Servo Amplifier Instruction Manual".

Item	Detailed explanation
Master-slave operation function	MR-J4-_B_ section 17.2

10.1 Compatible with MR-D30 functional safety unit

Point

For items other than the ones described in this section, refer to "MR-D30 Instruction Manual".
 Set "Using STO/SS1/SBC without executing position/speed observation (SLS/SSM/SOS/SS2) (_ _ 0 _)" or "Executing position/speed observation without the servo motor with functional safety (_ _ 2 _)" in [Pr. PSA02] of the encoder slave servo amplifiers. Setting "Executing position/speed observation with the servo motor with functional safety (_ _ 1 _)" in [Pr. PSA02] of the encoder slave servo amplifiers will trigger [AL. 7B.1 Encoder diagnosis error 1 (safety observation function)].

Description

Point

When using the safety observation function in the parallel drive system, use the I/O device of MR-D30.

Compatibility of safety observation function

Safety observation function	Safety observation function control by I/O device
STO	Category 4, PL e, SIL 3 ^{*1}
SS1	
SBC	
SLS	Category 4, PL e, SIL 3
SSM	Category 4, PL e, SIL 3 ^{*1}
SS2	
SOS	

*1 To meet Category 4, PL e, SIL 3 for input signals, a diagnosis using test pulses is required. Refer to section 4.1 in "MR-D30 Instruction Manual" for detailed conditions.

Safety observation function control by I/O device

A configuration example of the parallel drive system is shown in the following. With each MR-J4-DU_B4-RJ100 drive unit connected to MR-D30, the servo amplifier complies with safety level Category 4, PL e, SIL 3.

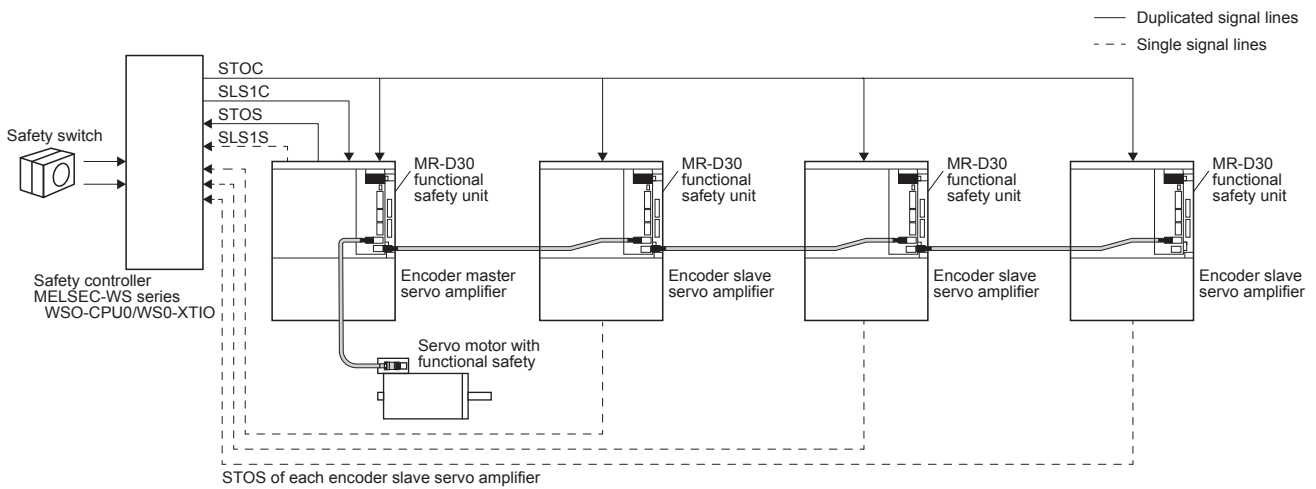

Connection diagram

Connecting safety controller and MR-D30

With MR-D30 used, the servo amplifier complies with safety level Category 4, PL e, SIL 3.

- Install MR-D30 in each MR-J4-DU_B4-RJ100 drive unit.
- Connect the wire for STO command (STOC) to each drive unit (the encoder master servo amplifier and each encoder slave servo amplifier).
- To execute speed observation, use the encoder master servo amplifier. Connect the wires of the duplicated SLS1C (SLS1 command), which is outputted from the safety controller, to the encoder master servo amplifier.
- After the encoder master servo amplifier becomes STO status in the speed observation, the command is processed in the safety controller (delayed by the input filter, input process, output process, etc.) and in the MR-D30 (taking 15 ms), and then the encoder slave servo amplifiers become STO status.

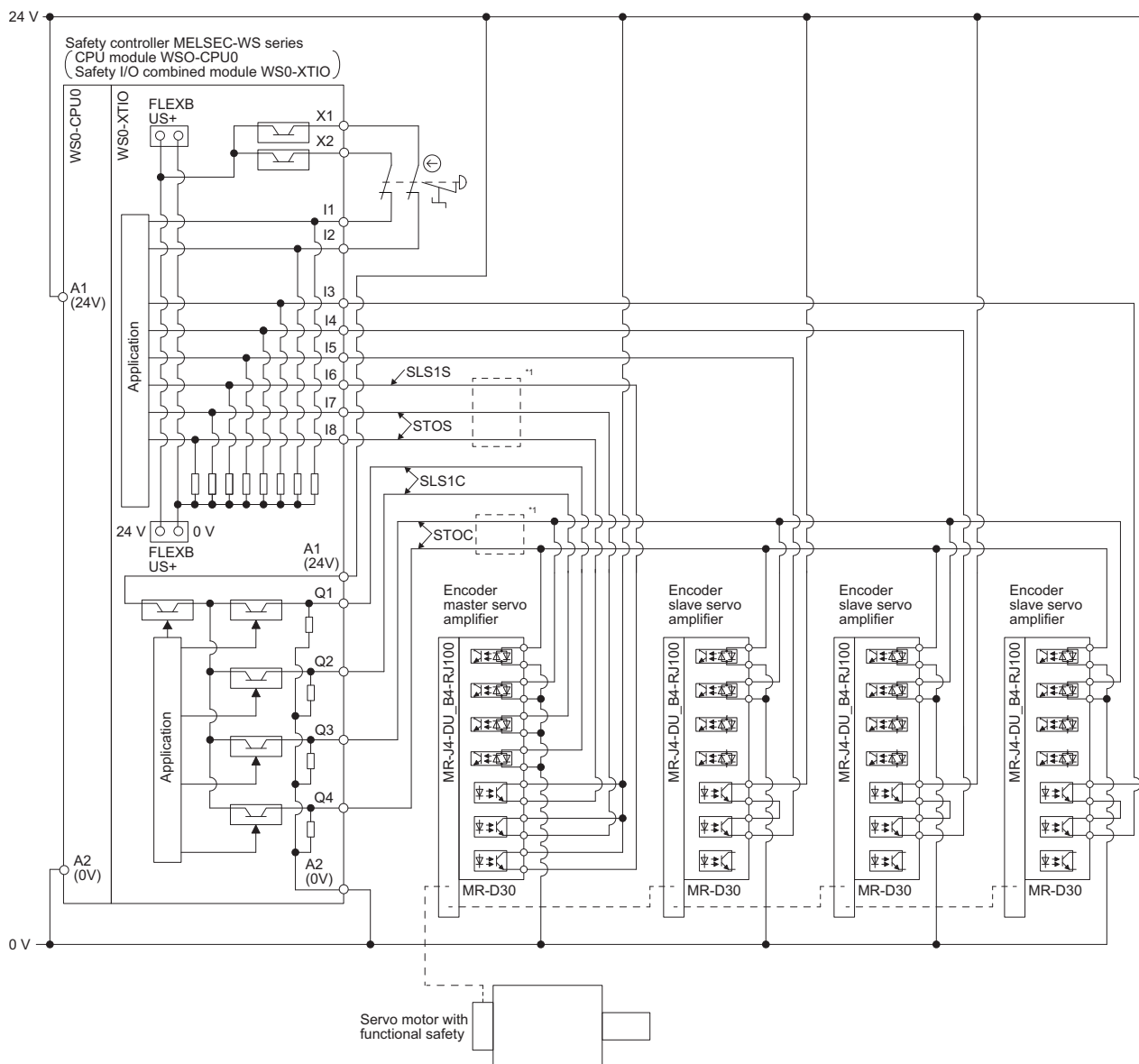

*1 When the motor speed exceeds the observation speed, the encoder master servo amplifier becomes STO status. Make STO status of the encoder slave servo amplifiers by the safety controller output. When STO is activated by an error in the speed observation, connect the wires for the duplicated STOS (STO output) of the encoder master servo amplifier to the safety controller. Connect the selected status monitor of the safety observation function (for example, SLS1S) to the safety controller. When an STOS signal of the encoder master servo amplifier is detected, input the duplicated STOC (STO command) from the safety controller to each encoder slave servo amplifier (and also to the encoder master servo amplifier, according to the circuit configuration).

Details of MR-D30

Encoder master servo amplifier

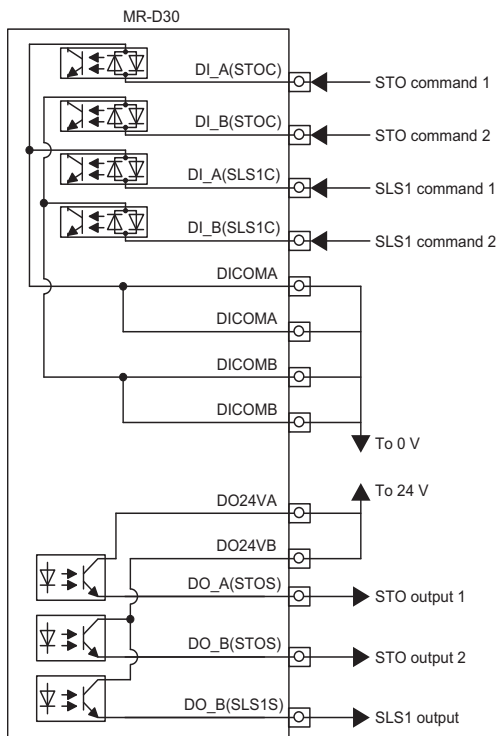

Encoder slave servo amplifier

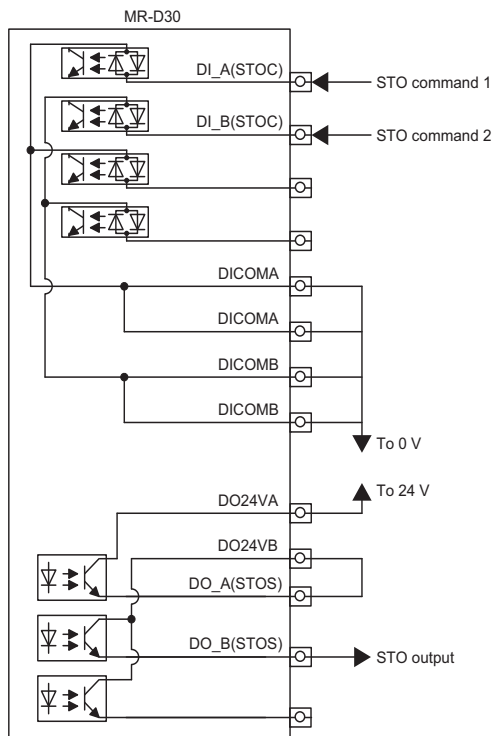

11 APPENDIX

The following items are the same as those for MR-J4-_B_(-RJ). Refer to the section of the detailed explanation field for details. "MR-J4-_B_" means "MR-J4-_B_(-RJ) Servo Amplifier Instruction Manual". "MR-J4-DU_B_" means "MR-CV_/MR-CR55K_/MR-J4-DU_(-RJ) Instruction Manual".

Item	Detailed explanation
Handling of AC servo amplifier batteries for the United Nations Recommendations on the Transport of Dangerous Goods	MR-J4-_B_ app. 2
Symbol for the new EU Battery Directive	MR-J4-_B_ app. 3
Compliance with global standards	MR-J4-DU_B_
EC declaration of conformity	MR-J4-DU_B_
Servo amplifier harmonic suppression measures	MR-J4-_B_ app. 7
SSCNET III cable (SC-J3BUS_M-C) manufactured by Mitsubishi Electric System & Service	MR-J4-_B_ app. 10
Special specifications	MR-J4-DU_B_
Optional data monitor function	MR-J4-_B_ app. 14
STO function with SIL 3 certification	MR-J4-_B_ app. 15
Status of general-purpose AC servo products for compliance with the China RoHS directive	MR-J4-DU_B_

11.1 Analog monitor

Point

For items other than the ones described in this section, refer to app. 11 in "MR-J4-_B_(-RJ) Servo Amplifier Instruction Manual".

Values of the maximum current command (maximum torque) when the analog monitor is ± 8 V are listed.

The following maximum torques are not nominal values, but are values with a sufficient margin considering servo motor variations.

The current command (torque) outputs the maximum current command (maximum torque) at ± 8 V. The maximum current command (maximum torque) may not match the rated current/maximum current ratio since it is created from the torque current in the drive unit.

Servo motor	Drive unit	Maximum current command (maximum torque) [%]
HG-JR110K24W0C	Two units of MR-J4-DU55KB4-RJ100	380
HG-JR150K24W0C	Four units of MR-J4-DU45KB4-RJ100	456
HG-JR180K24W0C	Four units of MR-J4-DU45KB4-RJ100	394
HG-JR200K24W0C	Four units of MR-J4-DU55KB4-RJ100	439
HG-JR220K24W0C	Four units of MR-J4-DU55KB4-RJ100	390

REVISIONS

*The manual number is given on the bottom left of the back cover.

Revision Date	*Manual Number	Description
May 2018	SH(NA)-030280ENG-A	First edition

Japanese manual number: SH-030279-A

This manual confers no industrial property rights or any rights of any other kind, nor does it confer any patent licenses. Mitsubishi Electric Corporation cannot be held responsible for any problems involving industrial property rights which may occur as a result of using the contents noted in this manual.

© 2018 MITSUBISHI ELECTRIC CORPORATION

WARRANTY

Warranty

1. Warranty period and coverage

We will repair any failure or defect hereinafter referred to as "failure" in our FA equipment hereinafter referred to as the "Product" arisen during warranty period at no charge due to causes for which we are responsible through the distributor from which you purchased the Product or our service provider. However, we will charge the actual cost of dispatching our engineer for an on-site repair work on request by customer in Japan or overseas countries. We are not responsible for any on-site readjustment and/or trial run that may be required after a defective unit are repaired or replaced.

[Term]

The term of warranty for Product is twelve (12) months after your purchase or delivery of the Product to a place designated by you or eighteen (18) months from the date of manufacture whichever comes first ("Warranty Period"). Warranty period for repaired Product cannot exceed beyond the original warranty period before any repair work.

[Limitations]

- (1) You are requested to conduct an initial failure diagnosis by yourself, as a general rule.
It can also be carried out by us or our service company upon your request and the actual cost will be charged. However, it will not be charged if we are responsible for the cause of the failure.
- (2) This limited warranty applies only when the condition, method, environment, etc. of use are in compliance with the terms and conditions and instructions that are set forth in the instruction manual and user manual for the Product and the caution label affixed to the Product.
- (3) Even during the term of warranty, the repair cost will be charged on you in the following cases;
 1. a failure caused by your improper storing or handling, carelessness or negligence, etc., and a failure caused by your hardware or software problem
 2. a failure caused by any alteration, etc. to the Product made on your side without our approval
 3. a failure which may be regarded as avoidable, if your equipment in which the Product is incorporated is equipped with a safety device required by applicable laws and has any function or structure considered to be indispensable according to a common sense in the industry
 4. a failure which may be regarded as avoidable if consumable parts designated in the instruction manual, etc. are duly maintained and replaced
 5. any replacement of consumable parts (battery, fan, smoothing capacitor, etc.)
 6. a failure caused by external factors such as inevitable accidents, including without limitation fire and abnormal fluctuation of voltage, and acts of God, including without limitation earthquake, lightning and natural disasters
 7. a failure generated by an unforeseeable cause with a scientific technology that was not available at the time of the shipment of the Product from our company
 8. any other failures which we are not responsible for or which you acknowledge we are not responsible for

2. Term of warranty after the stop of production

- (1) We may accept the repair at charge for another seven (7) years after the production of the product is discontinued. The announcement of the stop of production for each model can be seen in our Sales and Service, etc.
- (2) Please note that the Product (including its spare parts) cannot be ordered after its stop of production.

3. Service in overseas countries

Our regional FA Center in overseas countries will accept the repair work of the Product. However, the terms and conditions of the repair work may differ depending on each FA Center. Please ask your local FA center for details.

4. Exclusion of loss in opportunity and secondary loss from warranty liability

Regardless of the gratis warranty term, Mitsubishi shall not be liable for compensation to:

- (1) Damages caused by any cause found not to be the responsibility of Mitsubishi.
- (2) Loss in opportunity, lost profits incurred to the user by Failures of Mitsubishi products.
- (3) Special damages and secondary damages whether foreseeable or not, compensation for accidents, and compensation for damages to products other than Mitsubishi products.
- (4) Replacement by the user, maintenance of on-site equipment, start-up test run and other tasks.

5. Change of Product specifications

Specifications listed in our catalogs, manuals or technical documents may be changed without notice.

6. Application and use of the Product

- (1) For the use of our General-Purpose AC Servo, its applications should be those that may not result in a serious damage even if any failure or malfunction occurs in General-Purpose AC Servo, and a backup or fail-safe function should operate on an external system to General-Purpose AC Servo when any failure or malfunction occurs.
- (2) Our General-Purpose AC Servo is designed and manufactured as a general purpose product for use at general industries. Therefore, applications substantially influential on the public interest for such as atomic power plants and other power plants of electric power companies, and also which require a special quality assurance system, including applications for railway companies and government or public offices are not recommended, and we assume no responsibility for any failure caused by these applications when used
In addition, applications which may be substantially influential to human lives or properties for such as airlines, medical treatments, railway service, incineration and fuel systems, man-operated material handling equipment, entertainment machines, safety machines, etc. are not recommended, and we assume no responsibility for any failure caused by these applications when used. We will review the acceptability of the abovementioned applications, if you agree not to require a specific quality for a specific application. Please contact us for consultation.

TRADEMARKS

MELSERVO is a trademark or registered trademark of Mitsubishi Electric Corporation in Japan and/or other countries. All other product names and company names are trademarks or registered trademarks of their respective companies.

SH(NA)-030280ENG-A(1805)MEE

MODEL:

MODEL CODE:

MITSUBISHI ELECTRIC CORPORATION

HEAD OFFICE : TOKYO BUILDING, 2-7-3 MARUNOUCHI, CHIYODA-KU, TOKYO 100-8310, JAPAN
NAGOYA WORKS : 1-14 , YADA-MINAMI 5-CHOME , HIGASHI-KU, NAGOYA , JAPAN

When exported from Japan, this manual does not require application to the
Ministry of Economy, Trade and Industry for service transaction permission.

Specifications are subject to change without notice.