

FACTORY AUTOMATION

# SERVO AMPLIFIERS & MOTORS MELSERVO-J4

Man, machine and environment in perfect harmony

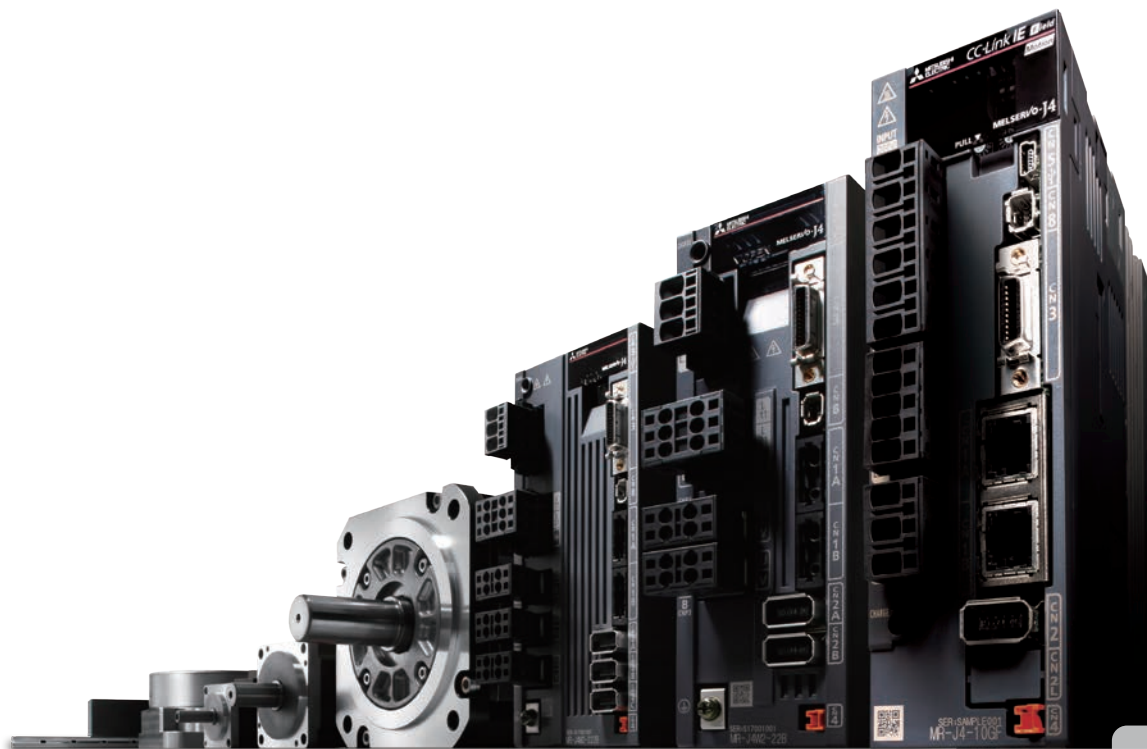

MITSUBISHI SERVO AMPLIFIERS & MOTORS

# MELSERVO

# J4





## Automating the World

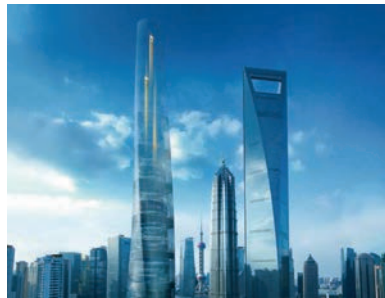

Our Factory Automation business is focused on "Automating the World" to make it a better, more sustainable environment supporting manufacturing and society, celebrating diversity and contributing towards an active and fulfilling role.

Mitsubishi Electric is involved in many areas including the following:

### **Energy and Electric Systems**

A wide range of power and electrical products from generators to large-scale displays.

### **Electronic Devices**

A wide portfolio of cutting-edge semiconductor devices for systems and products.

### **Home Appliance**

Dependable consumer products like air conditioners and home entertainment systems.

### **Information and Communication Systems**

Commercial and consumer-centric equipment, products and systems.

### **Industrial Automation Systems**

Maximizing productivity and efficiency with cutting-edge automation technology.



The Mitsubishi Electric Group is actively solving social issues, such as decarbonization and labor shortages, by providing production sites with energy-saving equipment and solutions that utilize automation systems, thereby helping towards a sustainable society.

# OVERVIEW

■ MELSERVO-J4 Product Lines .....	3
■ Harmony with Machine	
Basic Performance/Servo Gain Adjustment Function .....	8
A Variety of Functions .....	10
Network .....	15
■ Harmony with Man	
Safety Sub-Function .....	22
Maintenance Function .....	25
Easy to Use (Software) .....	27
■ Harmony with the Environment	
Multi-Axis Servo Amplifier .....	30
Energy-Saving System .....	31
■ Heritage	
Replacement .....	34
■ Features	
Basic Functions .....	37
Servo Amplifiers/Compatible Servo Motors .....	39
Rotary Servo Motors .....	41
Linear Servo Motors.....	43
Direct Drive Motors .....	45
Controllers .....	47
Solutions .....	51
Partners .....	54
■ Product Specifications	
Servo Amplifiers .....	1-1
Rotary Servo Motors .....	2-1
Linear Servo Motors.....	3-1
Direct Drive Motors .....	4-1
Options/Peripheral Equipment .....	5-1
Low-Voltage Switchgear/Wires .....	6-1
Product List .....	7-1
Precautions .....	8-1

A complete system lineup to meet your production and manufacturing needs

**CONTROLLER**

**Programmable controller**



MELSEC iQ-R series MELSEC-Q series MELSEC-QS/WS series MELSEC-L series

**Simple Motion module**

**CC-Link IE Field Network**



RJ71GF11-T2 QJ71GF11-T2 RD77GF QD77GF

**SSCNET III/H**



RD77MS QD77MS LD77MS FX5-SSC-S

**C Controller Interface Module**

**SSCNET III/H**



Q173SCCF

**INTERFACE**

**CC-Link IE Field Network**



**SSCNET III/H**



**SERVO AMPLIFIER SENSING MODULE**

CC-Link IE Field Network compatible servo amplifier



MR-J4-GF(-RJ)

SSCNET III/H compatible servo amplifier



MR-J4-B(-RJ)

SSCNET III/H compatible 2-axis servo amplifier



MR-J4W2-B

SSCNET III/H compatible 3-axis servo amplifier



MR-J4W3-B

\* Refer to the Instruction Manual about CC-Link IE Field Network Basic.

**SERVO MOTOR**

**Rotary servo motor**

Small capacity, low inertia  
**HG-KR series**  
Capacity: 50 to 750 W

Ultra-compact size, ultra-small capacity  
**HG-AK series**  
Capacity: 10 to 30 W

Small capacity, ultra-low inertia  
**HG-MR series**  
Capacity: 50 to 750 W

Medium capacity, ultra-low inertia  
**HG-RR series**  
Capacity: 1 to 5 kW

Medium capacity, medium inertia  
**HG-SR series**  
Capacity: 0.5 to 7 kW

Medium capacity, flat type  
**HG-UR series**  
Capacity: 0.75 to 5 kW

Medium/large capacity, low inertia  
**HG-JR series**  
Capacity: 0.5 to 55 kW

Ultra-large capacity  
**HG-JR series**  
Capacity: 110 to 220 kW









\* For the combinations of the servo amplifier and the servo motor, refer to pp. 1-4 to 1-8 in this catalog.

**SOLUTION**



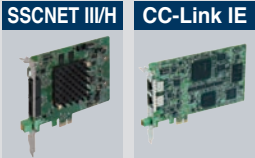

Mitsubishi Electric's e-F@ctory concept utilizes both FA and IT technologies, to reduce the total cost of development, production and maintenance, with the aim of achieving manufacturing that is a "step ahead of the times". It is supported by the e-F@ctory Alliance Partners covering software, devices, and system integration, creating the optimal e-F@ctory architecture to meet the end users needs and investment plans.

To respond to an expanding range of applications including semiconductor and FPD manufacturing, robots, and food processing machines, MELSERVO-J4 combines with other Mitsubishi Electric product lines such as Motion controllers, networks, graphic operation terminals, programmable controllers and more. This gives you the freedom and flexibility to create a more advanced servo system.

<b>Programmable controller</b>  MELSEC iQ-F/F series	<b>Graphic Operation Terminal</b>  GOT2000	<b>Personal computer</b> 	<b>SOFTWARE</b> MELSOFT GX Works3 MELSOFT MT Works2 MELSOFT MR Configurator2 MELSOFT Motorizer	<b>LOW-VOLTAGE SWITCHGEAR</b>	
			<b>Molded-case circuit breaker</b>  WS-V	<b>Magnetic contactor</b>  MS-T	
<b>Motion controller</b> <b>SSCNET III/H</b>  RnMTCPU Q17nDSCPU Q170MSCPU		<b>Personal computer embedded type</b> <b>SSCNET III/H</b> <b>CC-Link IE</b>  MR-MC2_ MR-EM340GF MR-MC341		<b>Positioning module</b>  RD75_ QD75_ LD75_ FX5-20PG_ FX3U-1PG	

<b>SSCNET III/H</b> 	<b>Pulse train/Analog voltage/RS-422/RS-485/MODBUS® RTU*</b> * RS-485 is supported only by MR-J4-A(-RJ). (Not supported by MR-J4-03A6-RJ) * MODBUS® RTU is supported only by MR-J4-A-RJ. (Not supported by MR-J4-03A6-RJ)
--	---

Power regeneration converter unit + SSCNET III/H compatible drive unit  MR-CV+MR-J4-DU_B(-RJ)	SSCNET III/H compatible sensing module  MR-MT2000 series	General-purpose interface servo amplifier  MR-J4-A(-RJ)
--	---	--





<b>Linear servo motor</b> Core type (natural/liquid cooling) <b>LM-F series</b> Rating: 300 to 3000 N (natural cooling) Rating: 600 to 6000 N (liquid cooling) Core type with magnetic attraction counter-force <b>LM-K2 series</b> Rating: 120 to 2400 N Coreless type <b>LM-U2 series</b> Rating: 50 to 800 N	<b>Direct drive motor</b> Low-profile flange type <b>TM-RG2M series</b> Rating: 2.2 to 9 N·m Low-profile table type <b>TM-RU2M series</b> Rating: 2.2 to 9 N·m High rigidity <b>TM-RFM series</b> Rating: 2 to 240 N·m
---	---

**PLATFORM**  Mitsubishi Electric's integrated FA platform for achieving lateral integration of controllers & HMI, engineering environments and networks at production sites.

# MELSERVO-J4 Product Lines





## Servo amplifier

●: Supported    -: Not supported

Servo amplifier <sup>(*)6</sup>	Number of control axes	Power supply specifications	Rated output [kW] <sup>(*)1,4</sup>	Command interface				Control mode			Fully closed loop control <sup>(*)5</sup>														
				CC-Link IE Field	SSCNET III/H	Pulse train	Analog voltage RS-422/MODBUS® RTU	Position	Speed	Torque	Positioning function	HG-KR	HG-MR	HG-SR	HG-JR	HG-AK	HG-RR	HG-UR	LM-H3	LM-F	LM-K2	LM-U2	TM-RG2M	TM-RU2M	TM-RFM
<b>CC-Link IE Field Network</b> 	1 axis	1-phase 100 V AC	0.1, 0.2, 0.4	●	-	-	-	●	●	●	●	●	●	-	-	-	●	-	●	●	●	●	●	●	
		3-phase 200 V AC	0.1, 0.2, 0.4, 0.6, 0.75, 1, 2, 3.5, 5, 7, 11, 15, 22	●	-	-	-	●	●	●	●	●	●	●	-	●	●	●	●	●	●	●	●	●	●
		3-phase 400 V AC	0.6, 1, 2, 3.5, 5, 7, 11, 15, 22	●	-	-	-	●	●	●	●	●	●	●	-	-	-	●	-	-	-	-	-	-	-
<b>SSCNET III/H</b>   	1 axis	1-phase 100 V AC	0.1, 0.2, 0.4	-	●	-	-	●	●	●	-	●	●	-	-	-	●	-	●	●	●	●	●	●	
		3-phase 200 V AC	0.1, 0.2, 0.4, 0.6, 0.75, 1, 2, 3.5, 5, 7, 9, 11, 15, 22, 30, 37	-	●	-	-	●	●	●	-	●	●	●	●	-	●	●	●	●	●	●	●	●	●
		3-phase 400 V AC	0.6, 1, 2, 3.5, 5, 7, 9, 11, 15, 22, 30, 37, 45, 55	-	●	-	-	●	●	●	-	●	●	●	●	-	-	-	●	-	-	-	-	-	-
	2 axes	3-phase 200 V AC	0.2, 0.4, 0.75, 1	-	●	-	-	●	●	●	-	●	●	●	-	●	-	-	-	-	-	-	-	-	
<b>General-purpose interface</b> 	1 axis	1-phase 100 V AC	0.1, 0.2, 0.4	-	-	●	●	●	●	●	●	●	-	-	-	●	-	●	●	●	●	●	●	●	
		3-phase 200 V AC	0.1, 0.2, 0.4, 0.6, 0.75, 1, 2, 3.5, 5, 7, 11, 15, 22, 30, 37	-	-	●	●	●	●	●	●	●	●	-	●	●	●	●	●	●	●	●	●	●	●
		3-phase 400 V AC	0.6, 1, 2, 3.5, 5, 7, 11, 15, 22, 30, 37, 45, 55	-	-	●	●	●	●	●	●	●	●	-	●	●	●	-	●	-	-	-	-	-	-
		48 V DC 24 V DC	0.03	-	-	●	●	●	●	●	●	●	●	-	-	-	-	-	-	-	-	-	-	-	-

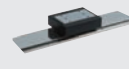
\*1. The values listed are the rated output of the servo amplifier. For the compatible servo motor capacities, refer to pp. 1-4 to 1-8 in this catalog.  
 \*2. MR-J4-GF/B/A servo amplifier is compatible with a two-wire type serial linear encoder. For four-wire type serial linear encoders and pulse train interface (A/B/Z-phase differential output type) linear encoders, use MR-J4-GF-RJ/B-RJ/A-RJ servo amplifier.  
 \*3. The positioning function and MODBUS® RTU are supported by MR-J4-A-RJ. Note that MR-J4-03A6-RJ does not support MODBUS® RTU.  
 \*4. A converter unit is necessary for the drive unit.  
 \*5. MR-J4-GF/B/A servo amplifier is compatible with two-wire type and four-wire type serial linear encoders. For a pulse train interface (A/B/Z-phase differential output type) linear encoder, use MR-J4-GF-RJ/B-RJ/A-RJ servo amplifier.  
 \*6. The functions listed are supported by the servo amplifiers with the latest software version. (As of August 2023) Refer to relevant servo amplifier instruction manuals for the supporting software versions.







## Linear servo motor

Linear servo motor series	Maximum speed [m/s]	Continuous thrust [N] <sup>(*)1</sup>	Maximum thrust [N] <sup>(*)1</sup>	Cooling method	Features	Application examples
<b>LM-H3 series</b> 	3.0	70, 120, 240, 360, 480, 720, 960	175, 300, 600, 900, 1200, 1800, 2400	Natural cooling	Suitable for space-saving. Compact size and high thrust. Maximum speed: 3 m/s.	<ul style="list-style-type: none"> <li>Mounters</li> <li>Wafer cleaning systems</li> <li>FPD assembly machines</li> <li>Material handlings</li> </ul>
<b>LM-F series</b> 	2.0	300, 600, 900, 1200, 1800, 2400, <span style="border: 1px solid black; padding: 1px;">3000</span>	1800, 3600, 5400, 7200, 10800, 14400, <span style="border: 1px solid black; padding: 1px;">18000</span>	Natural cooling	Compact size. The integrated liquid-cooling system doubles the continuous thrust.	<ul style="list-style-type: none"> <li>Press feeders</li> <li>NC machine tools</li> <li>Material handlings</li> </ul>
	2.0	600, 1200, 1800, 2400, 3600, 4800, <span style="border: 1px solid black; padding: 1px;">6000</span>	1800, 3600, 5400, 7200, 10800, 14400, <span style="border: 1px solid black; padding: 1px;">18000</span>	Liquid cooling		
<b>LM-K2 series</b> 	2.0	120, 240, 360, 720, 1200, 1440, 2400	300, 600, 900, 1800, 3000, 3600, 6000	Natural cooling	High thrust density. Magnetic attraction counter-force structure enables longer life of the linear guides and lower audible noise.	<ul style="list-style-type: none"> <li>Mounters</li> <li>Wafer cleaning systems</li> <li>FPD assembly machines</li> </ul>
<b>LM-U2 series</b> 	2.0	50, 75, 100, 150, 225, 400, 600, 800	150, 225, 300, 450, 675, 1600, 2400, 3200	Natural cooling	No cogging and small speed fluctuation. No magnetic attraction force structure extends life of the linear guides.	<ul style="list-style-type: none"> <li>Screen printing systems</li> <li>Scanning exposure systems</li> <li>Inspection systems</li> <li>Material handlings</li> </ul>

\*1.    : For 400 V.

## Rotary servo motor

●: Available    —: Not available

Rotary servo motor series	Rated speed (maximum speed) [r/min]	Rated output [kW] (*1)	Servo motor type (*2)			IP rating (*3)	Replaceable series	Features	Application examples
			With electromagnetic brake (B)	With gear reducer (G1)	With gear reducer (G5, G7)				
<b>Small capacity</b> 	<b>HG-KR series</b> 3000 (6000)	0.05, 0.1, 0.2, 0.4, 0.75	●	●	●	IP65	HF-KP series	Low inertia Perfect for general industrial machines.	•Belt drives •Robots •Mounters •X-Y tables •Semiconductor manufacturing equipment
	<b>HG-MR series</b> 	3000 (6000)	0.05, 0.1, 0.2, 0.4, 0.75	●	—	—	IP65	HF-MP series	Ultra-low inertia Well suited for high-throughput operations.
<b>Medium capacity</b> 	<b>HG-SR series</b> 1000 (1500)	0.5, 0.85, 1.2, 2.0, 3.0, 4.2	●	—	—	IP67	HF-SP series	Medium inertia This series is available with two rated speeds.	•Material handling systems •Robots •X-Y tables
	2000 (3000)	0.5, 1.0, 1.5, 2.0, 3.5, 5.0, 7.0 0.5, 1.0, 1.5, 2.0, 3.5, 5.0, 7.0	●	●	●	IP67			
<b>Medium/large/ultra-large capacity</b> 	<b>HG-JR series</b> 3000 (6000: 0.5 to 5 kW 5000: 7, 9 kW)	0.5, 0.75, 1.0, 1.5, 2.0, 3.5, 5.0, 7.0, 9.0 0.5, 0.75, 1.0, 1.5, 2.0, 3.5, 5.0, 7.0, 9.0	●	—	—	IP67	HF-JP series	Low inertia Well suited for high-throughput and high-acceleration/ deceleration operations.	•Food packaging machines •Printing machines
	1500 (3000: 7 to 15 kW 2500: 22 to 55 kW)	7.0, 11, 15, 22, 30, 37 7.0, 11, 15, 22, 30, 37, 45, 55	● (*5)	—	—	IP67/ IP44 (*4)	HF-JP HA-LP series		•Injection molding machines •Press machines
	1000 (2000: 6 to 12 kW 1500: 15 to 37 kW)	6.0, 8.0, 12, 15, 20, 25, 30, 37 6.0, 8.0, 12, 15, 20, 25, 30, 37	● (*5)	—	—	IP67/ IP44 (*4)	HA-LP series		
	2000 (3000)	110, 150, 180, 200, 220	—	—	—	IP44	HF-JP series		
<b>Ultra-small capacity</b> 	<b>HG-AK series</b> 3000 (6000)	0.01, 0.02, 0.03	●	—	—	IP55	HC-AQ series	Ultra-compact size Suitable for small machines.	•Mounters •Semiconductor manufacturing equipment •Compact robot •Electric component manufacturing machines
<b>Medium capacity</b> 	<b>HG-RR series</b> 3000 (4500)	1.0, 1.5, 2.0, 3.5, 5.0	●	—	—	IP65	HC-RP series	Ultra-low inertia Well suited for high-throughput operations.	•Ultra-high-throughput material handling systems
<b>Medium capacity, flat type</b> 	<b>HG-UR series</b> 2000 (3000: 0.75 to 2 kW 2500: 3.5, 5 kW)	0.75, 1.5, 2.0, 3.5, 5.0	●	—	—	IP65	HC-UP series	Flat type The flat design makes this unit well suited for situations where the installation space is limited.	•Robots •Food processing machines

\*1.  : For 400 V.



\*2. G1 for general industrial machines. G5 and G7 for high precision applications.

\*3. The shaft-through portion is excluded. Refer to the asterisk 7 of "Annotations for Rotary Servo Motor Specifications" on p. 2-41 in this catalog for the shaft-through portion. For geared servo motor, IP rating of the reducer portion is equivalent to IP44.

\*4. For HG-JR1500 r/min series, 15 kW or smaller is rated IP67, and 22 kW or larger is rated IP44. For HG-JR 1000 r/min series, 12 kW or smaller is rated IP67, and 15 kW or larger is rated IP44.

\*5. The servo motor with electromagnetic brake is not available for HG-JR 1500 r/min series 22 kW or larger, and 1000 r/min series 15 kW or larger.

## Direct drive motor

Direct drive motor series	Motor outer diameter [mm]	Hollow shaft diameter [mm]	Rated speed [r/min]	Maximum speed [r/min]	Rated torque [N·m]	Maximum torque [N·m]	IP rating (*1)	Features	Application examples
<b>Low-profile</b> 	<b>TM-RG2M/TM-RU2M series</b> ø130	ø20	300	600	2.2	8.8	IP40	•Suitable for low-speed and high-torque operations. •Smooth operation with less audible noise. •The motor's low profile design contributes to compact construction and a low center of gravity for enhanced machine stability. •Clean room compatible.	•Semiconductor manufacturing devices •Liquid crystal manufacturing devices •Machine tools
	ø180	ø47	300	600	4.5	13.5	IP40		
	ø230	ø62	300	600	9	27	IP40		
<b>High-rigidity</b> 	<b>TM-RFM series</b> ø130	ø20	200	500	2, 4, 6	6, 12, 18	IP42		
	ø180	ø47	200	500	6, 12, 18	18, 36, 54	IP42		
	ø230	ø62	200	500	12, 48, 72	36, 144, 216	IP42		
	ø330	ø104	100	200	40, 120, 240	120, 360, 720	IP42		

\*1. Connectors and a gap along the rotor (output shaft) are excluded.

# Machine

MITSUBISHI SERVO AMPLIFIERS & MOTORS  
**MELSERVO-**

# J4

---

The leading edge in drive control,  
with unrivaled accuracy and  
response for next-generation  
machine performance.

---

Backed by Mitsubishi Electric MELSERVO's  
global track record of proven reliability,  
the new MR-J4 takes machine  
performance to the highest level.



Industry-leading level 2.5 kHz speed frequency response, with servo amplifiers, servo motors, and networks linked in symphonic productivity

MELSER/o-J4 | Industry-Leading Basic Performance

Industry-Leading Level of Servo Amplifier Basic Performance



A speed frequency response of 2.5 kHz is achieved by applying our original high-speed servo control architecture evolved from the conventional two-degrees-of-freedom model adaptive control to the dedicated execution engine. Together with a high-resolution absolute position encoder of 4,194,304 pulses/rev, fast and accurate operation is enabled. The performance of the high-end machines is utilized to the fullest.

[Settling time comparison with the prior model]

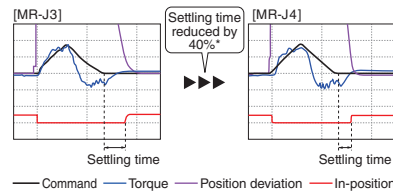

\*The result is based on our evaluation condition.

[Dedicated execution engine]

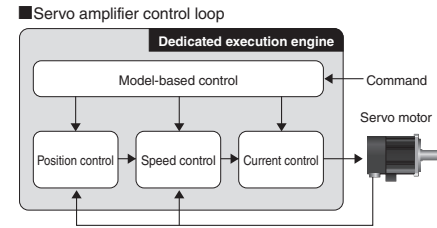

Improving Machine Performance with High-Performance Servo Motors



With improved processing speed, the rotary servo motors equipped with a high-resolution encoder enables high-accuracy positioning and smooth rotation.

[Resolution comparison with the prior model]

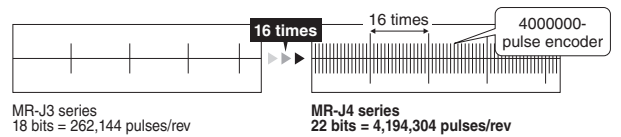

One-Touch Tuning



Just turn on the one-touch tuning function to complete servo gain adjustment automatically, including machine resonance suppression filter, advanced vibration suppression control II\*, and robust filter for maximizing your machine performance. This function also sets responsiveness automatically, while the real-time auto tuning requires manual setting. Moreover, a new method\*\*2 allows to create an optimum tuning command inside the servo amplifier.

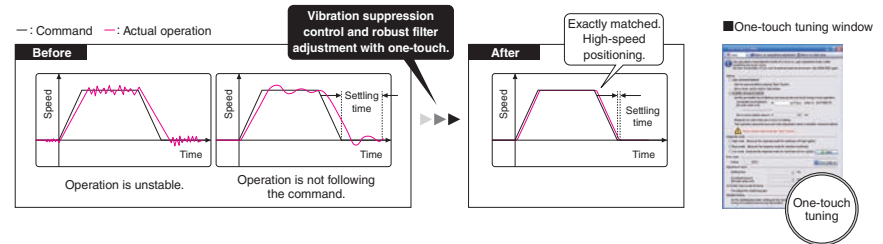

\*1.The advanced vibration suppression control II automatically adjusts one frequency.  
\*2.This new method is supported by MR-J4-B/MR-J4W\_-B/MR-J4-A.

Advanced Vibration Suppression Control II



The advanced vibration suppression control II suppresses two types of low-frequency vibrations, owing to vibration suppression algorithm which supports three-inertia system. This function is effective in suppressing residual vibration with relatively low frequency of approximately 100 Hz or less generated at the end of an arm and in a machine, enabling a shorter settling time.

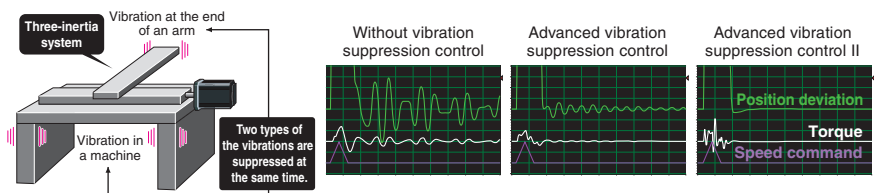

Application examples

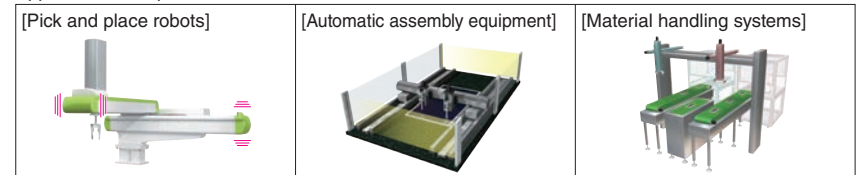

## Robust Filter

Patented

Achieving both high responsivity and stability was difficult with the conventional control in high-inertia systems with belts and gears such as printing and packaging machines. Now, this function enables the high responsivity and the stability at the same time without adjustment. The robust filter gradually reduces the fluctuation of torque in a wide frequency range and achieves more stability as compared to the prior model.

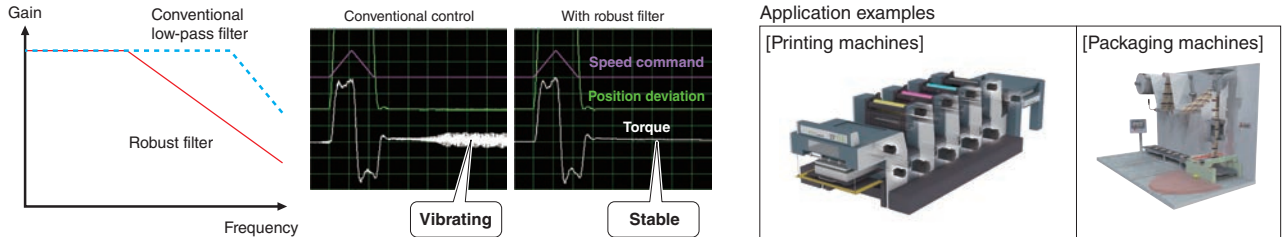

## Expanded Machine Resonance Suppression Filter

Enhanced functions

With advanced filter structure, applicable frequency range is expanded from between 100 Hz and 4500 Hz to between 10 Hz and 4500 Hz. Additionally, the number of simultaneously applicable filters is increased from two to five, improving vibration suppression performance of a machine.

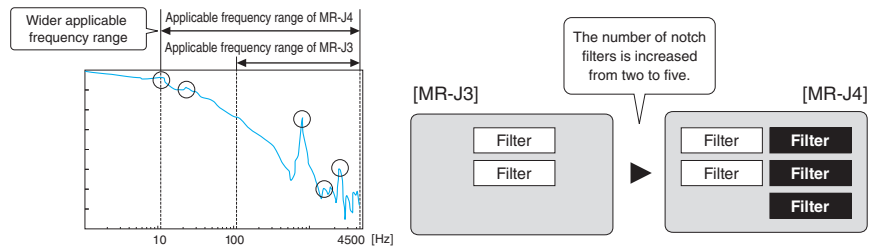

## Lost Motion Compensation Function

This function suppresses quadrant protrusion caused by friction and torsion generated when the servo motor rotates in a reverse direction. Therefore, the accuracy of circular path will be improved in trajectory control used in XY table, etc.

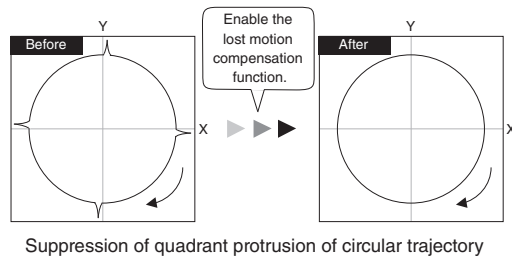

Application example

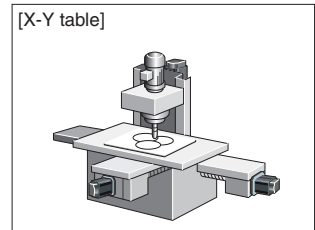

\* This function is not supported by MR-J4W2-B and MR-J4W3-B.

## Super Trace Control

This function reduces a position deviation to nearly zero not only during constant-velocity operation, but also during constant acceleration/deceleration. The trajectory accuracy will be improved in high-rigidity machines.

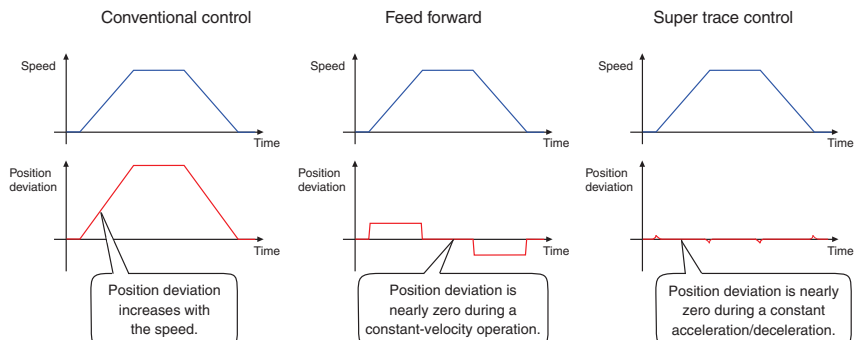

\* This function is not supported by MR-J4W2-B and MR-J4W3-B.

MELSER/6-J4 | A Variety of Functions for Various Applications

\* Use a compatible controller.

Tightening & Press-Fit Control

	RnMTCPU	Q17nDSCPU	Q170MSCPU	Patented
FX5SSC	RD77MS	QD77MS	LD77MS	

This function switches position/speed control mode to torque control mode smoothly without a stop or a sudden change in speed and torque, and thus reduces load to a machine. This function is best suit for an application where control is switched from position to torque such as Tightening & Press-fit control or insertion of a work, and cap or screw tightening.

\* This function is supported by MR-J4-B/MR-J4W2-B/MR-J4W3-B.

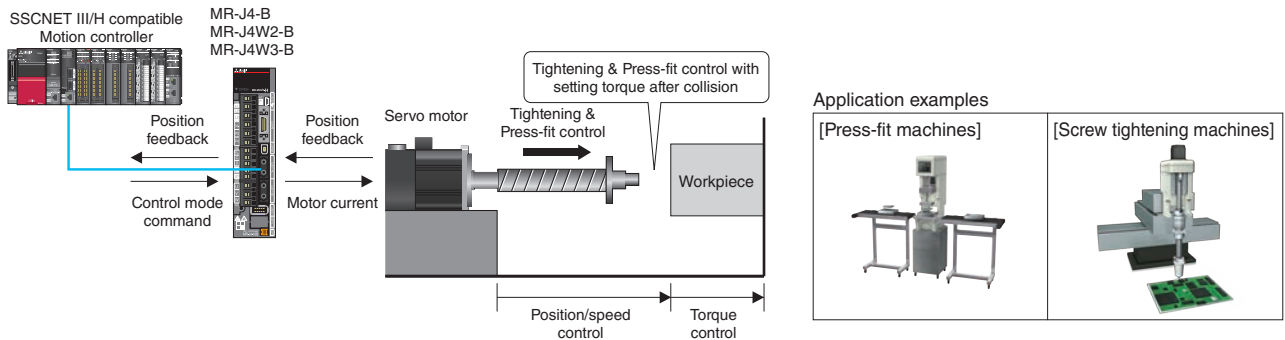

Driver Communication Function

	RnMTCPU	Q17nDSCPU	Q170MSCPU
FX5SSC	RD77MS	QD77MS	LD77MS

The controller controls the master axis by using the driver communication function of MR-J4-B servo amplifiers. The servo amplifier of the master axis transmits the torque data to the other servo amplifiers on SSCNET III/H, and the others also drive the servo motors on the basis of the torque data transmitted from the master axis. The data is transmitted via SSCNET III/H, and thus no special wiring is necessary.

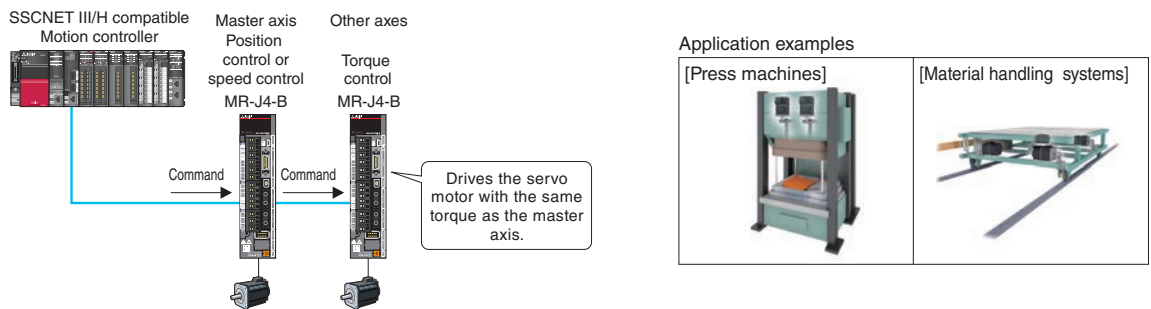

Scale Measurement Function

	RnMTCPU	Q17nDSCPU	Q170MSCPU		
RD77GF	QD77GF	FX5SSC	RD77MS	QD77MS	LD77MS

The scale measurement function of MR-J4-GF/MR-J4-B/MR-J4W2-B\*1 servo amplifiers\*2 enables to transmit position information of a scale measurement encoder to the controller when the scale measurement encoder is connected in semi closed loop control.

The data of linear or synchronous encoders are transmitted to the servo system controller via the servo amplifier, resulting in less wiring.

\*1. This function is not supported by MR-J4W2-0303B6.  
 \*2. Use corresponding servo amplifier (MR-J4-GF/MR-J4-GF-RJ/ MR-J4-B/MR-J4-B-RJ) for load-side encoder.

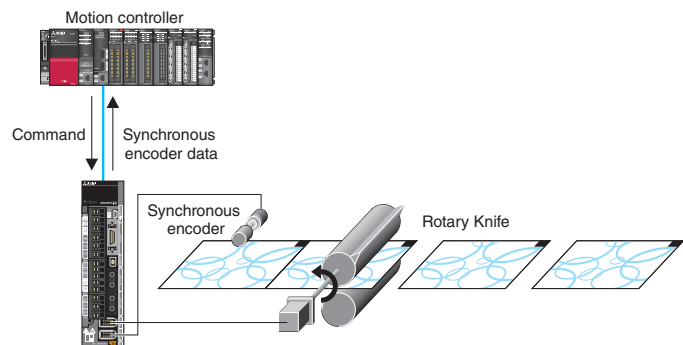

Fully closed loop control supported as standard.  
Operate rotary servo motors, linear servo motors, or direct drive motors.

MELSERVO-J4 | Applicable for Various Control and Driving Systems

### Compatible Servo Motors

MR-J4 series servo amplifier operates rotary servo motors, linear servo motors, and direct drive motors as standard\*.

\* Not all of the servo amplifiers are compatible with all three of these servo motors. For the combination, refer to "Product lines" on p. 39 in this catalog.



Rotary servo motor



Linear servo motor

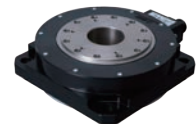

Direct drive motor

### 1-axis/2-axis/3-axis Servo Amplifiers

For SSCNET III/H compatible servo amplifiers, 2-axis and 3-axis types are available in addition to 1-axis type, enabling flexible systems based on the number of control axes.



MR-J4-B



MR-J4W2-B



MR-J4W3-B

### Supporting Fully Closed Loop Control

Supporting a fully closed loop control system<sup>1</sup> as standard, MR-J4-GF/MR-J4-B/MR-J4-A servo amplifiers enable further precise positioning<sup>2</sup>.

<sup>1</sup> MR-J4-GF/MR-J4-B/MR-J4-A servo amplifier is compatible with two-wire type serial linear encoders. For four-wire type serial and pulse train interface (A/B/Z-phase differential output type) linear encoders, use MR-J4-GF-RJ/MR-J4-B-RJ/MR-J4-A-RJ.

<sup>2</sup> Some models do not support a fully closed loop control system. Refer to "Product lines" on p. 39 in this catalog.

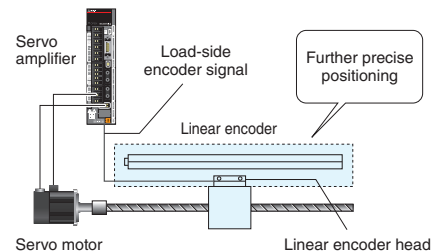

### Wide Range of Power Supplies and Capacities

Each servo amplifier supports the following main circuit power supplies:  
MR-J4-B/MR-J4-A: 3-phase 200 V AC/400 V AC,  
1-phase 100 V AC, and 48 V DC/24 V DC

They also support a wide range of capacities from 30 W\* to 55 kW.

MR-J4-GF: 3-phase 200 V AC/400 V AC, 1-phase 100 V AC

MR-J4-GF-RJ/MR-J4-B-RJ/MR-J4-A-RJ also supports DC

power input.

\* Servo amplifier of 30 W supports a power supply of 48 V DC/24 V DC.



MR-J4-10B1



MR-J4-22KB



MR-CR55K4 + MR-J4-DU55KB4

### Maximum Command Pulse Frequency

General-purpose interface compatible MR-J4-A servo amplifier supports maximum command pulse frequency of 4 Mpulses/s (when differential receiver is used).

When open collector is used, both sink and source inputs are enabled.

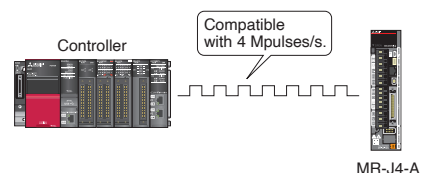

# Positioning System without a Positioning Module

MELSER/o-J4

Built-in Positioning Function for Simple System

## MR-J4-GF(-RJ) and MR-J4-A-RJ with Built-in Positioning Function

MR-J4-GF(-RJ) and MR-J4-A-RJ have a built-in positioning function, enabling positioning operation with point table, program-based\*, and indexer methods. With these servo amplifiers, a positioning system is configured without a Positioning module (command pulse). Positioning command is executed by CC-Link IE Field network, input/output signals, or RS-422/RS-485 communication (up to 32 axes). MR Configurator2 allows easy setting of the positioning data.

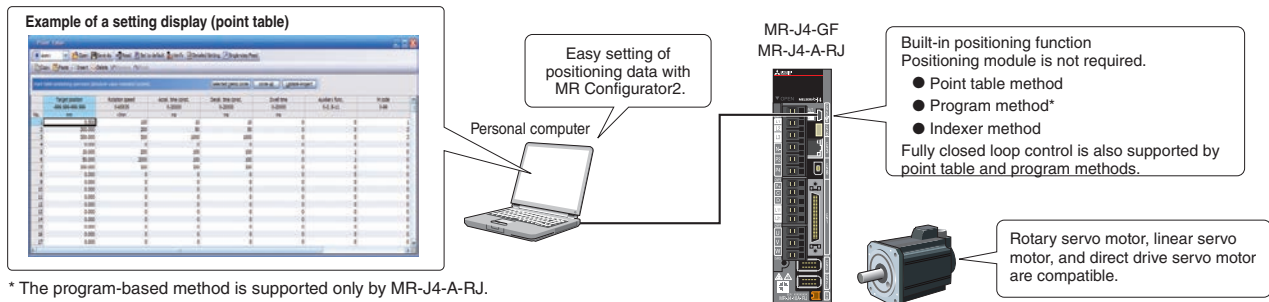

### Point table method

GF

GF-RJ

A-RJ

Set position data (target position), servo motor speed, and acceleration/deceleration time constants in point table. Setting the point table data (settable up to 255 points) is as easy as setting parameters. Perform positioning operation with a start signal after selecting the point table Nos.

Point table example

Point table No.	Position data	Servo motor speed	Acceleration time constant	Deceleration time constant	Dwell	Sub function	M code
1	1000	2000	200	200	0	1	1
2	2000	1600	100	100	0	0	2
⋮	⋮	⋮	⋮	⋮	⋮	⋮	⋮
255	3000	3000	100	100	0	2	99

\* For MR-J4-A-RJ, point table can be set with push buttons on the servo amplifier or with MR-PRU03 parameter unit.

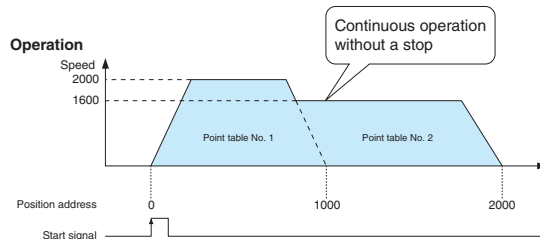

### Program method\*

A-RJ

Create positioning programs with dedicated commands, and perform positioning operation with a start signal after selecting the program Nos. The program-based method enables more complex positioning operation than the point table method. Maximum of 256 programs are settable. (The total number of steps of all programs: 640)

Program example

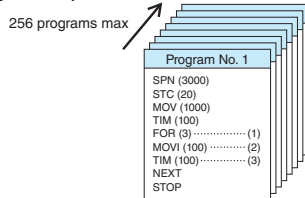

\* MR Configurator2 is required to create programs.

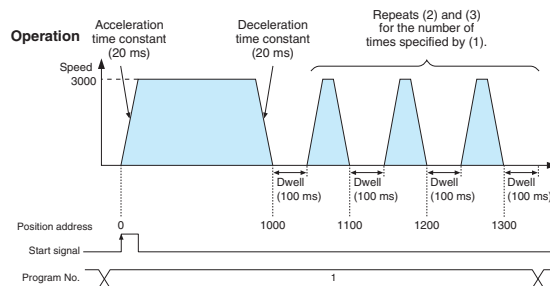

### Indexer method\*

GF

GF-RJ

A-RJ

Perform positioning operation by specifying equally divided stations (up to 255 stations) and the number of gear teeth on machine and motor sides. The travel distance will be calculated automatically based on the number of equally divided stations set in the parameter. The positioning operation is performed with a start signal after the station position Nos. are selected.

Rotation direction specifying indexer or shortest rotating indexer can be set.

\* Fully closed loop control mode and linear servo motor control mode are not supported by the indexer method.

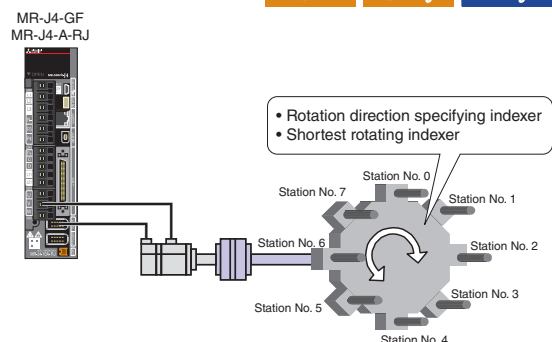

MELSERIO-J4 | New Useful Functions with Positioning Function

\* Not supported by MR-J4-03A6-RJ.

New useful functions are added to the positioning function: simple cam function, encoder following function, pulse input through function, simple cam position compensation function, and communication functions (MODBUS® RTU, Point to Point positioning, and current position latch function). Apply these useful functions to a wide variety of applications to configure positioning system easily.

**Simple cam function**

GF GF-RJ A-RJ

Various patterns of cam data are created easily with MR Configurator2. Command pulse or point table/program start signal is used as input to the simple cam. The input command will be outputted to the servo motor according to the cam data.

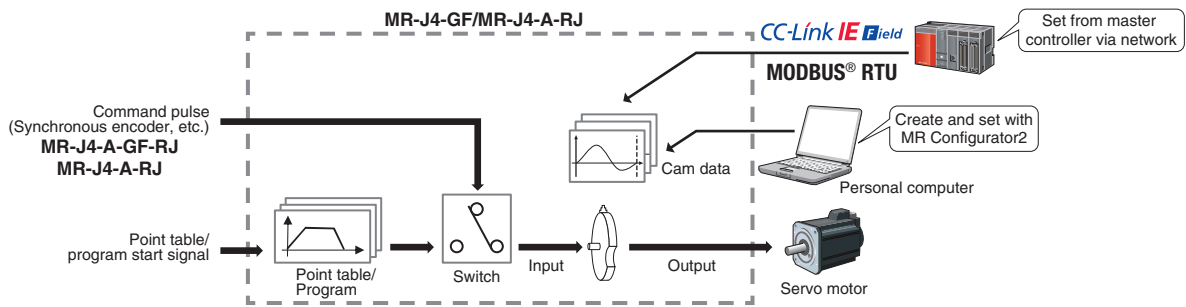

\* The program-based method is supported only by MR-J4-A-RJ.

**Encoder following function/Pulse input through function\***

GF-RJ A-RJ

With the encoder following function, the servo amplifier receives A/B-phase output signal from the synchronous encoder as command pulse, and the input command will be outputted to the servo motor according to the cam data. Setting cam data that matches with the sheet length, a circumference of the rotary knife axis, and the synchronous section of the sheet enables a system in which the conveyor axis and the rotary knife axis are synchronized. Up to 4 Mpulses/s of input from a synchronous encoder is compatible with the servo amplifier.

The pulse input through function allows the first axis to output A/B-phase pulses which are received from the synchronous encoder to the next axis, enabling a system in which the subsequent axes are synchronized with the synchronous encoder.

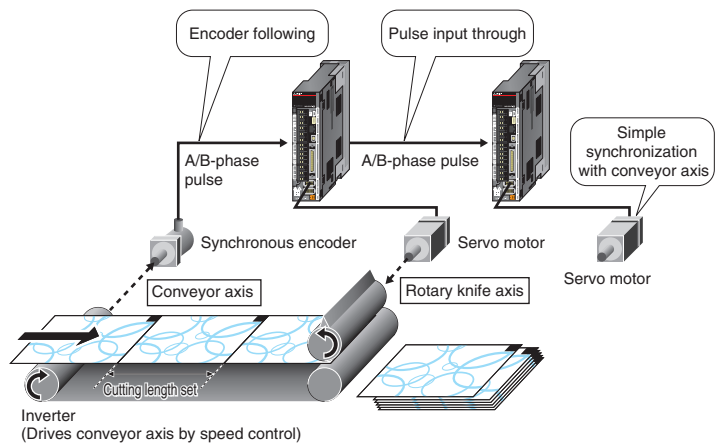

\* The pulse input through function is available as A/B-phase pulse input through function for MR-J4-GF-RJ and as command pulse input through function for MR-J4-A-RJ.

**Simple cam position compensation function\***

GF-RJ A-RJ

The actual position of the servo motor is obtained based on the inputs from the sensor that detects the registration marks printed on the high-speed moving film. The servo amplifier calculates compensation amounts and corrects position errors of the rotary knife axis based on those inputs from the sensor so that the film is cut at the set position.

\* "Cam position compensation request" is turned on with touch probe input for MR-J4-GF-RJ and mark sensor input for MR-J4-A-RJ.

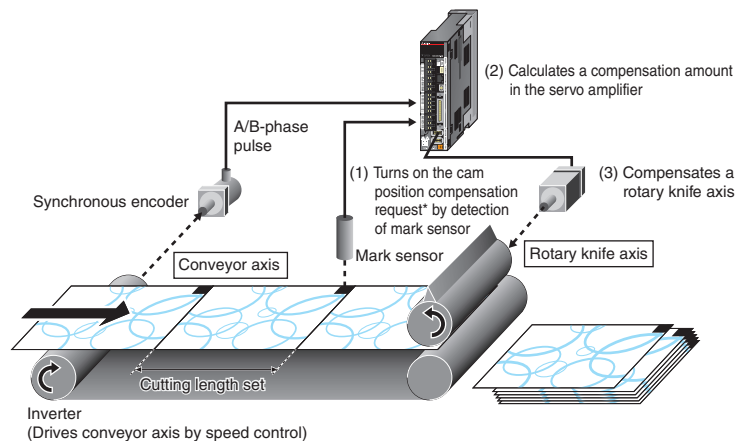

### Communication function (MODBUS® RTU)

A-RJ

In addition to RS-422/RS-485 communication (Mitsubishi Electric general-purpose AC servo protocol), RS-485 communication (MODBUS® RTU protocol) is supported. MODBUS® RTU protocol is compatible with function code 03h (Read holding registers), etc. Controlling and monitoring of the servo amplifier is possible by external devices.

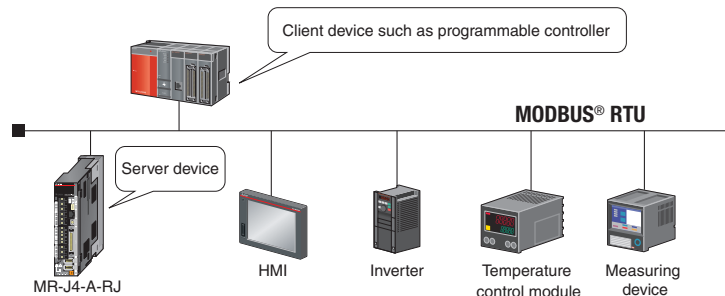

\* RJ-45 junction connector terminal block and RJ-45 compatible cable designed for MR-J4-A-RJ are required.

### Communication function (Point to Point positioning)

GF

GF-RJ

A-RJ

Up to 255 points of Point to Point positioning are enabled when the target position is set in the point table in advance. Rewriting the next target position during an operation is also possible by the communication function.

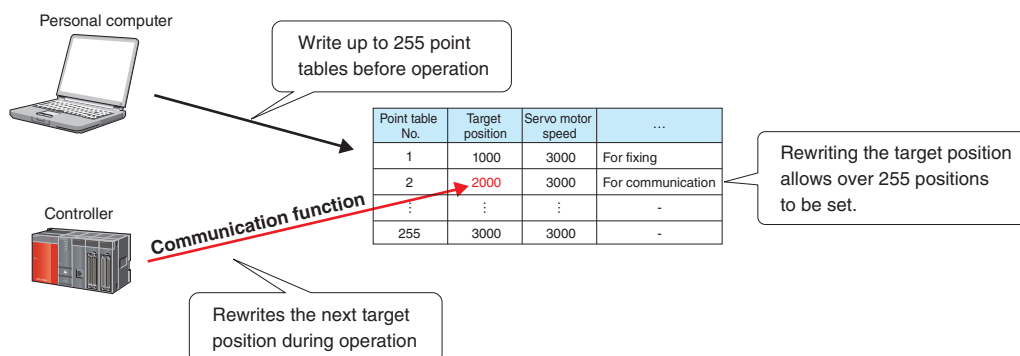

### Communication function (current position latch)

A-RJ

Based on the data latched by the mark detection function (current position latch\*), a target position is compensated by being written in the point table.

\* When the mark detection signal turns on, a current position will be latched, and the latched data will be read with the communication function.

Example: Executing positioning compensation when a product is mispositioned by 50 on a handling pallet.

Start an operation by specifying point table No. 1 (target position: 1000).

Communication function (current position latch) measures a position gap with the mark detection function and writes the position gap of 50 to the target position in point table No. 2 for compensation during the operation.

After the operation of point table No. 1 is completed with a position gap of 50, start the operation by specifying point table No. 2.

The product will be set to the right position.

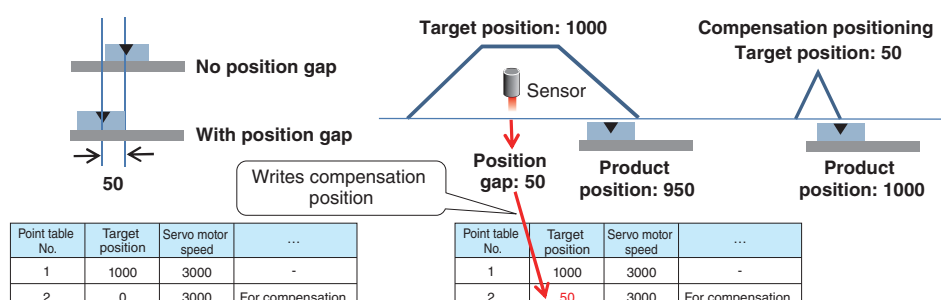



MELSERIO-J4 | All-Rounder Network with CC-Link IE Field

All-in-One Network

The network is designed to simultaneously handle distributed control, I/O control, and motion control. CC-Link IE Field Network lets you connect field devices such as programmable controllers, I/O modules, high-speed counter modules, servo amplifiers, inverters, and displays, providing optimal network which best fits the needs of the application. Choose from star, line, or ring\* topology suitable for layout of lines and machines.



Communication speed <b>1 Gbps</b>	Maximum link registers <b>16K words</b>	Maximum link relays <b>32,768 bits</b>	<b>Star topology</b>	<b>Line topology</b>	<b>Ring topology*</b>
<b>Easy to configure parameters</b>	<b>Network diagnosis at-a-glance</b>	<b>Seamless connectivity</b>	<b>Twisted pair cable</b>	<b>Ethernet-based</b>	<b>Motion control Synchronized communication</b>

\* The Simple Motion modules do not support a ring topology.



10010100110

A major innovation in industrial networks providing reliable, flexible, and seamless communication

## All-in-One Engineering Software

This all-in-one MELSOFT GX Works3 covers all aspects of the product development cycle from system design to maintenance - including programming, setting of CC-Link IE Field Network and Simple Motion modules, and adjustment of servo amplifiers.



### Easy system design

- MELSOFT GX Works3 includes everything needed from system configuration to servo parameter settings.
- Parameters for CC-Link IE Field Network are easy to be set.

[Servo parameter]



[CC-Link IE Field network configuration]



System Design

Programming

### Easy motion control

[Positioning data]

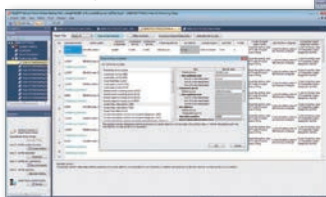

[Synchronous control parameter]



- An array of auxiliary functions helps you create positioning data.
- Synchronous control is performed easily just by parameter settings.
- Creation of a rough cam waveform on a graph via drag & drop, or direct numerical value input to the graph enables easy creation of cam data.

### Easy programming

- A sequence program is created effortlessly via drag & drop of module labels/FBs.

[Sequence program]

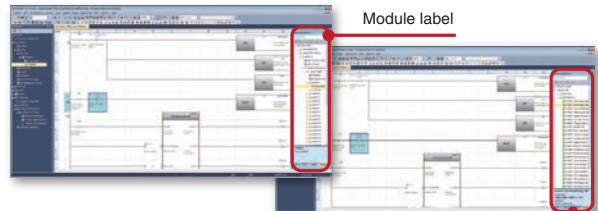

Debug

Maintenance

### Easy startup

[One-touch tuning]



[Network diagnostics]



- Servo adjustment is automatically completed using the One-touch tuning function.
- Network diagnostics displays the network errors.
- Debugging of a program without an actual machine is possible by simulation.

# CC-Link IE Field Network-Compatible Servo Amplifier MR-J4-GF

MELSERVO-J4 | All-Rounder Driving System with CC-Link IE Field

## Compatible with CC-Link IE Field Network

MR-J4-GF(-RJ) is compatible with CC-Link IE Field Network as standard.

The servo amplifier is connectable with Ethernet-based CC-Link IE Field Network, enabling high-speed, seamless communication.

MR-J4-GF



## Easy Positioning with CC-Link IE Field Network

A combination of a master module and MR-J4-GF(-RJ) allows positioning operation with point table method or indexer method, not requiring a Positioning module. With the point table method, just set the point table No. and turn on the start signal, and then the positioning operation will be started. A continuous operation of the next point table is also possible without stopping. In the indexer method, the travel amount is automatically calculated based on the number of stations set in the parameter. For more details of the positioning function, refer to pp. 12 to 14 in this catalog.

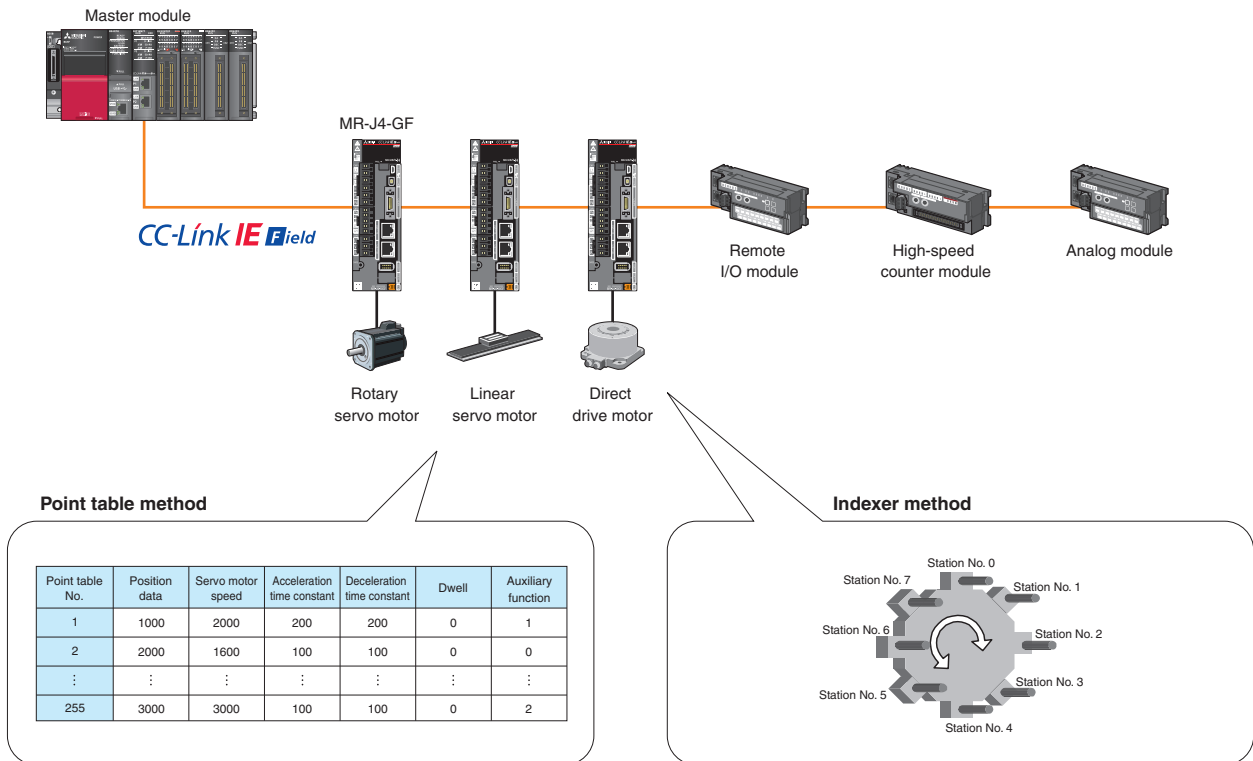

## CC-Link IE Field Network Motion Control

A combination of a Simple Motion module and MR-J4-GF(-RJ) enables high-performance synchronous control and interpolation control with simple parameter setting and a start from a sequence program. Speed control and torque control are also possible, suitable for converting machines. In addition, using remote inputs/outputs which are compatible with the synchronized communication function enables a system synchronized with the command cycle of the servo amplifier.

### An example of inputs/outputs synchronized with the command cycle of the servo amplifier

A synchronous encoder, unwinder, printing machine can be synchronized with the servo command communication cycle.

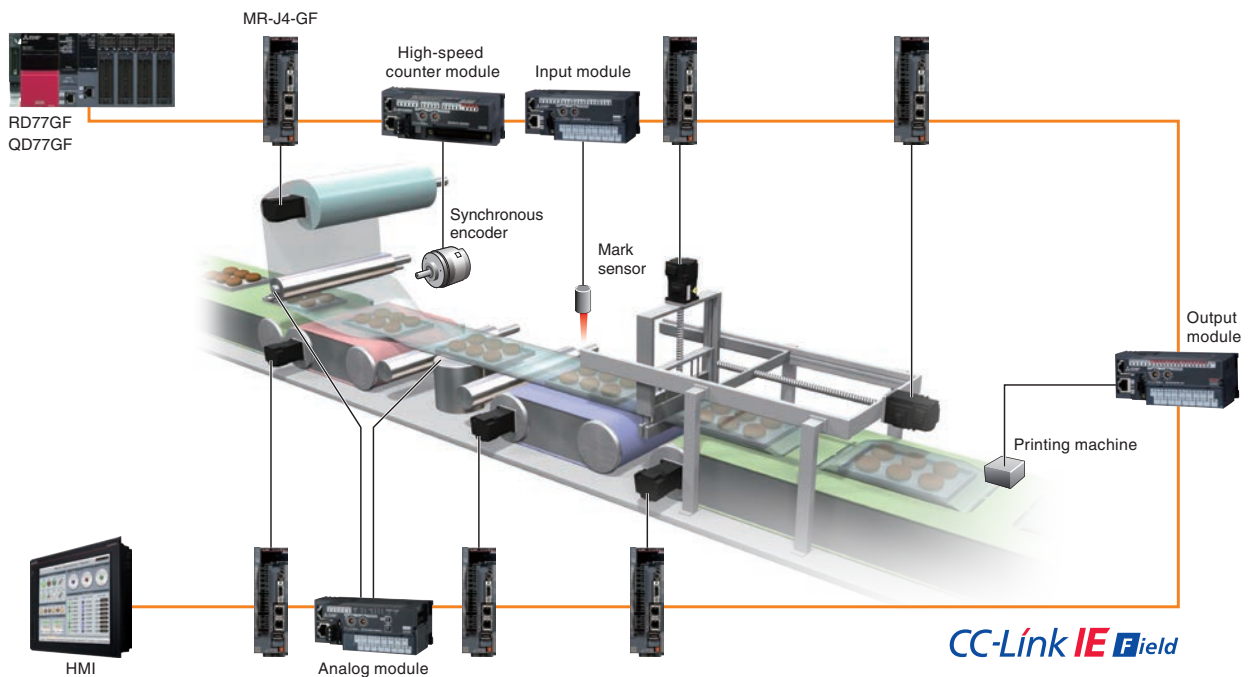

## Supporting CC-Link IE Field Network Basic<sup>\*3</sup>

CC-Link IE Field Basic

With recent trends of IoT<sup>\*1</sup>, network connection of devices and equipment for small-scale systems are becoming more mainstream. CC-Link IE Field Network Basic realizes easier network integration of Ethernet devices, as its cyclic communications stack is software-based, without requiring a dedicated ASIC helping to reduce implementation costs for device partners.

Transparent communications are achieved by utilizing SLMP<sup>\*2</sup> that enables seamless connectivity within all levels of manufacturing.

\*1. Internet of Things

\*2. Seamless Message Protocol

\*3. CC-Link IE Field Network Basic is supported by MR-J4-GF with software version A4 or later. Refer to the Instruction Manual for CC-Link IE Field Network Basic.

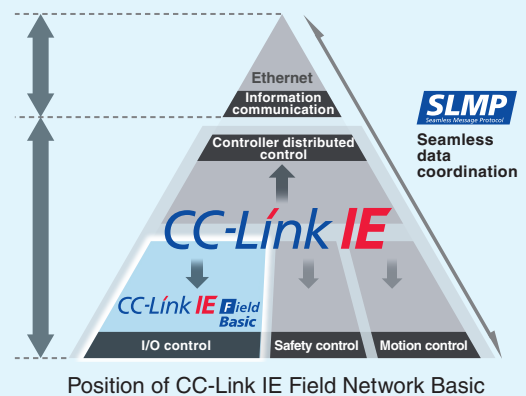



The blazingly fast

MELSERIO-J4 | High-Response Servo System Achieved with SSCNET III/H

Three Times Faster Communication Speed Industry-leading levels

Communication speed is increased to 150 Mbps full duplex (equivalent to 300 Mbps half duplex), three times faster than the conventional speed. System response is dramatically improved.

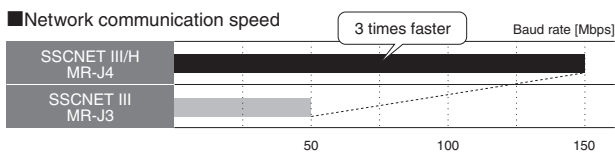

Cycle Time as Fast as 0.222 ms Industry-leading levels

Smooth control of a machine is possible using high-speed serial communication with a cycle time of 0.222 ms.

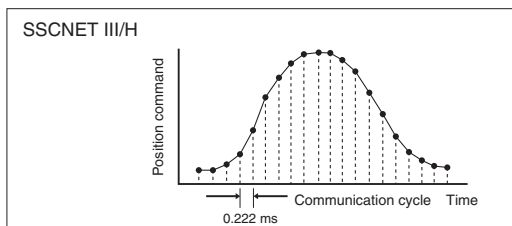
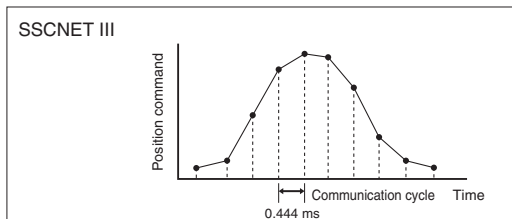

Synchronous Communication

Synchronous communication is achieved with SSCNET III/H, offering technical advantages for machines in printing and food processing industry that require deterministic control.

■ Timing of servo amplifier processing

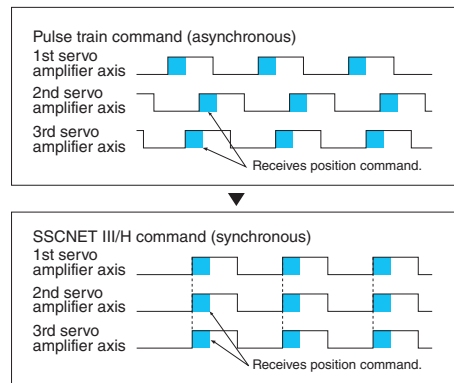

Improved Noise Tolerance by Optical Communication

The fiber-optic cables thoroughly shut out noise that enters from the power cable or external devices. Noise tolerance is dramatically improved as compared to metal cables.

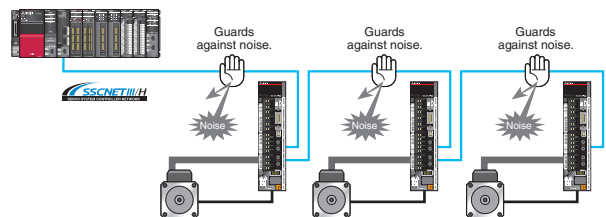

# speed and response of 150 Mbps full-duplex baud rate SSCNET III/H optical networking

## Long Distance Wiring up to 3200 m Enhanced performance

Long distance wiring is possible up to 3200 m per system (maximum of 100 m between stations × 32 axes), suitable for large-scale systems.

\* This is when all axes are connected via SSCNET III/H.

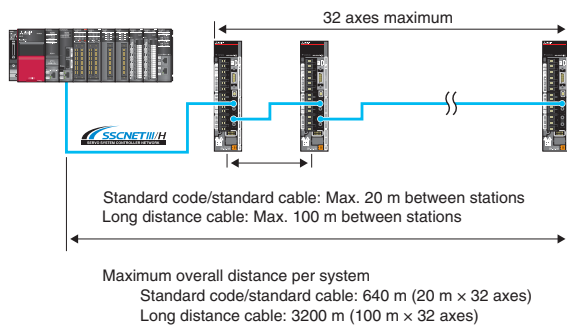

## Central Control with Network

Large amounts of servo data are exchanged in real-time between the controller and the servo amplifier. Using MELSOFT MR Configurator2 on a personal computer that is connected to the Motion controller or the Simple Motion module helps consolidate information such as parameter settings and monitoring for the multiple servo amplifiers.

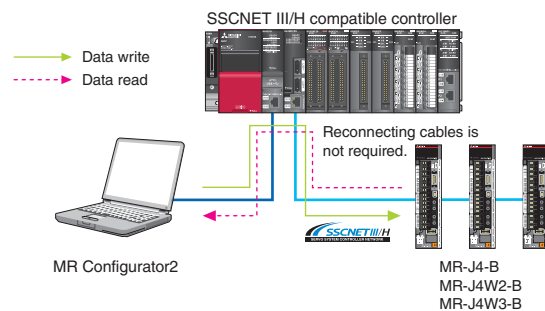

## Network Topology

Star and line topologies are available with MR-MV200 optical hub unit\* through SSCNET III/H for a network configuration. Maintenance can be executed without stopping the whole system, and thus the operation rate will be increased.

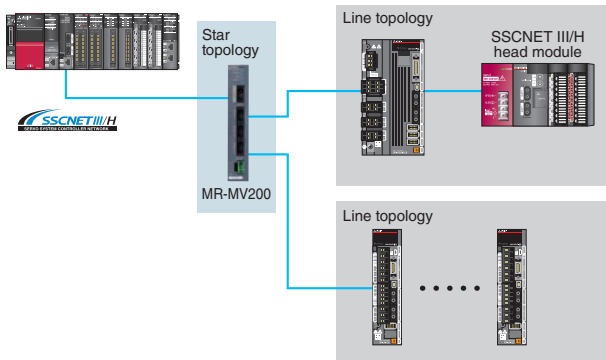

## I/O Signals Synchronized with Motion Control

MR-MT2000 series sensing modules including the I/O module, analog I/O module, pulse I/O module, and encoder I/F module are connected to SSCNET III/H.

These various modules enable a faster, more accurate machine operation by synchronizing the I/Os of a general-purpose pulse train driver, sensor, and SSI encoder with the motion control.

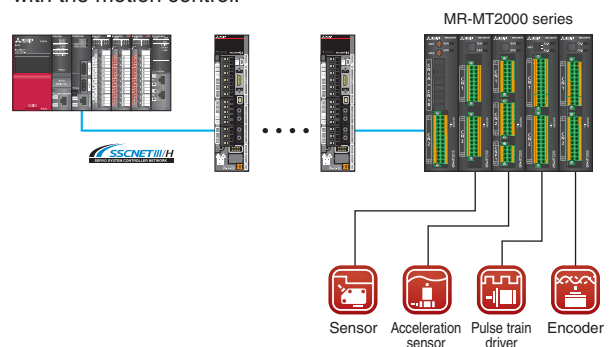

\* For MR-MV200 optical hub unit and MR-MT2000 sensing module, refer to "Servo System Controllers MELSEC iQ-R series/MELSEC iQ-F series catalog (L(NA)03100)".

---

The leading edge in safety  
and convenience, designed to  
harmonize with the way you work.

---

The easy-to-use MR-J4 was created with human needs in mind. It meets world-class safety standards and is exceptionally simple to maintain, ensuring optimum setup and operating ease for both design and manufacturing personnel.

# Man



MITSUBISHI SERVO AMPLIFIERS & MOTORS  
**MELSERVO-**

# J4



## Advanced features for world-class safety

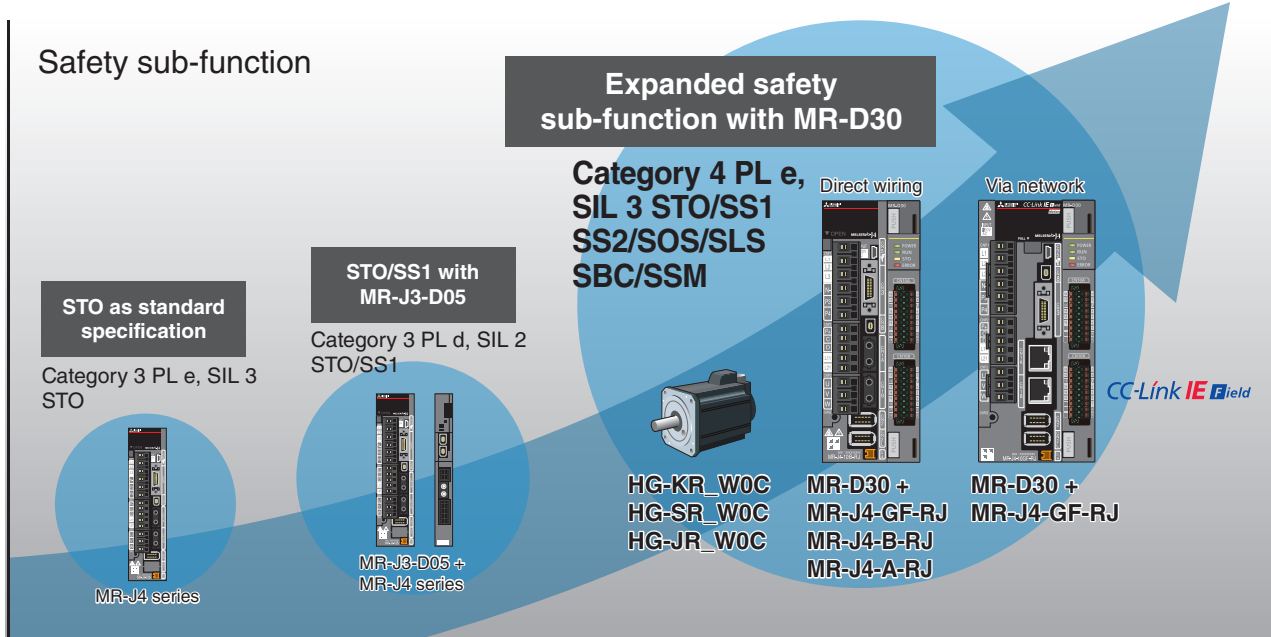

MELSER/o-J4 | Equipped with the Safety Sub-Function

### Functions Compliant with IEC/EN 61800-5-2

STO (Safe torque off) and SS1\*1 (Safe stop 1) are integrated as standard, enabling the safety system to be configured easily in a machine.

- By using STO, it is not necessary to turn off the control power of the servo amplifier, resulting in a shorter restart time and eliminating the necessity of home position return.
- A magnetic contactor for preventing unexpected motor start is not needed.\*2
- The safety level of STO is increased to SIL 3 from SIL 2. \*3,4

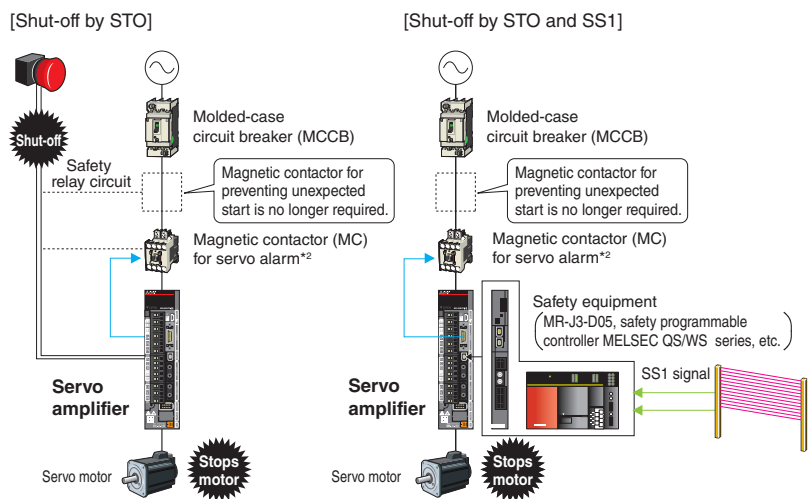

IEC/EN 61800-5-2:2007 function	Safety level
STO (Safe torque off)	Category 3 PL e, SIL 3 *3,4
SS1 (Safe stop 1) *1	

\*1. Safety equipment (MR-J3-D05, safety programmable controller MELSEC QS/WS series, etc.) is required.  
 \*2. For MR-J4 series servo amplifier, magnetic contactors are not required to meet the STO requirements. However, this illustration has a magnetic contactor installed to prevent servo alarms and electric shock.  
 \*3. Servo amplifiers manufactured in Japan in June 2015 or later, or in China in December 2015 or later are required, and a parameter needs to be set.  
 \*4. For Category 3 PL e, SIL 3, use compatible safety equipment and set the parameters. When MR-J3-D05 is used, safety level is Category 3 PL d, SIL 2.

## Increasing Safety Level with MR-D30 Functional Safety Unit

### Achieving Category 4 PL e, SIL 3

#### ● By wiring to MR-D30 functional safety unit

Safety level is Category 4 PL e, SIL 3 when the safety signals are inputted directly to MR-D30 functional safety unit. The safety sub-function is operated on the MR-D30 by parameter setting, and therefore expansion of the safety sub-function is possible independent of controllers.

IEC/EN 61800-5-2:2007 function	Safety level
STO (Safe torque off)	Category 4 PL e, SIL 3
SS1 (Safe stop 1)	
SS2 (Safe stop 2)* <sup>1</sup>	
SOS (Safe operating stop)* <sup>1</sup>	
SLS (Safely-limited speed)* <sup>2</sup>	
SSM (Safe speed monitor)* <sup>2</sup>	

\*1. Requires the use of a servo motor with functional safety.

\*2. Safety level is Category 3 PL d, SIL 2 when the servo motor with functional safety is not used.

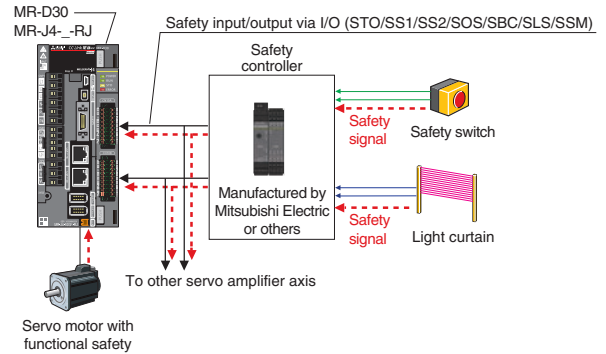

#### ● By CC-Link IE Field Network

When MR-J4-GF-RJ is combined with R\_SFPCPU-SET safety CPU and RD77GF Simple Motion module, MR-J4-GF-RJ receives the safety signal data through CC-Link IE Field Network connected to RD77GF, and thus wiring the safety signals to the I/O of MR-D30 is not necessary.

IEC/EN 61800-5-2:2007 function	Safety level
STO (Safe torque off)	Category 4 PL e, SIL 3
SS1 (Safe stop 1)	
SS2 (Safe stop 2)* <sup>1</sup>	
SOS (Safe operating stop)* <sup>1</sup>	
SLS (Safely-limited speed)* <sup>2</sup>	
SSM (Safe speed monitor)* <sup>2</sup>	

\*1. Requires the use of a servo motor with functional safety.

\*2. Safety level is Category 3 PL d, SIL 2 when the servo motor with functional safety is not used.

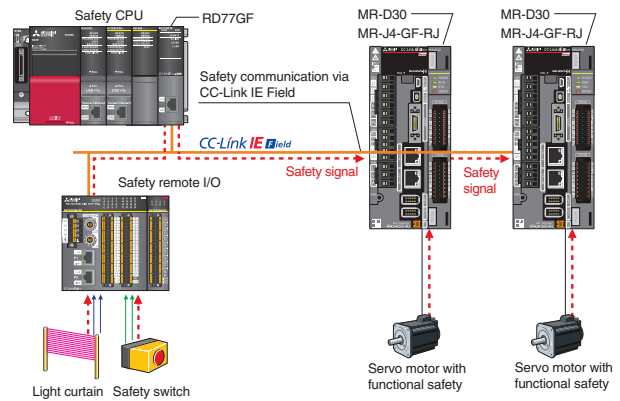

## Related Catalogs



Refer to "Safety Programmable Controller/Safety Controller catalog (L(NA)08192E)" for details.



# Achieving IEC/EN 61800-5-2 Functions

- (1) Functions achievable with MR-J4-GF(-RJ)/MR-J4-B(-RJ)/MR-J4W\_-B/MR-J4-A(-RJ)
- (2) Functions achievable with MR-J3-D05 and MR-J4-GF(-RJ)/MR-J4-B(-RJ)/MR-J4W\_-B/MR-J4-A(-RJ)
- (3) Functions achievable with MR-D30 + MR-J4-GF-RJ/MR-J4-B-RJ/MR-J4-A-RJ

⊙: Supported (SIL 3) ○: Supported (SIL 2) -: Unsupported

IEC/EN 61800-5-2:2007 function	(1)	(2)	(3)	IEC/EN 61800-5-2:2007 function	(1)	(2)	(3)
<p><b>Safe torque off (STO)</b></p> <p>The STO function shuts off power to the motor electronically using the internal circuit by responding to the input signal from external equipment (shuts off through secondary-side output). This function corresponds to the Stop category 0 of IEC/EN 60204-1.</p> <p>Execute the STO function in servo off state or when the motor is stopped.</p>	⊙*1	○	○	<p><b>Safely-limited speed (SLS)</b></p> <p>This function monitors the motor not to exceed the required speed limit. If the speed exceeds the limit, the motor power is shut off by the STO.</p>	-	-	⊙*3
<p><b>Safe stop 1 (SS1)</b></p> <p>Responding to the input signal from external equipment, the motor starts to decelerate. After the set delay time for motor stop is passed, the STO function starts. This function corresponds to the Stop category 1 of IEC 60204-1.</p>	-	○	○	<p><b>Safe brake control (SBC)</b></p> <p>The SBC signals are outputted for external brake control.</p>	-	-	○
<p><b>Safe stop 2 (SS2)</b></p> <p>Responding to the input signal from external equipment, the motor starts to decelerate. After the set delay time for motor stop is passed, the SOS function starts. This function corresponds to the Stop category 2 of IEC/EN 60204-1.</p>	-	-	⊙*2	<p><b>Safe speed monitor (SSM)</b></p> <p>The SSM signals are outputted when the motor speed is below the specified speed limit.</p>	-	-	⊙*3
<p><b>Safe operating stop (SOS)</b></p> <p>This function monitors the position of the motor not to deviate from the specified range. Power is still supplied to the motor during the SOS function.</p>	-	-	⊙*2	<p>V: Speed Vmax: User specified speed limit value S1, S2: Specified stop position</p> <p>■ Function activation area</p>			

\*1. SIL 3 when a necessary parameter is set.  
 \*2. Requires the use of a servo motor with functional safety.  
 \*3. SIL 2 without the use of a servo motor with functional safety.

## Enhanced operating ease and drive stability

MELSERVO-J4 | Maintenance Function to Achieve TCO\* Reduction | \*TCO: Total Cost of Ownership

### Compliance with SEMI-F47

MELSERVO-J4 series servo amplifier complies with SEMI-F47 standard\* corresponding to semiconductors and FPD manufacturing systems. (SEMI-F47 is not applicable to 1-phase 100 V AC, 1-phase 200 V AC, and DC input. To comply with SEMI-F47 with 9 kW or larger servo amplifiers, the dynamic brake is not usable.)

\* The control power supply of the servo amplifier complies with SEMI-F47. Note that the backup capacitor may be required depending on the power impedance and operating situation for the instantaneous power failure of the main circuit power supply. Be sure to perform a test on your machine to meet the SEMI-F47 Voltage Sag Immunity Standard. Please use the 3-phase power supply for the servo amplifier input.

### Tough Drive Function

Enhanced functions

#### Instantaneous power failure tough drive

When an instantaneous power failure is detected, this function allows the servo amplifier to use the electric energy charged in the main circuit capacitor in the servo amplifier to avoid an alarm occurrence, increasing the machine availability even with an unstable power supply.

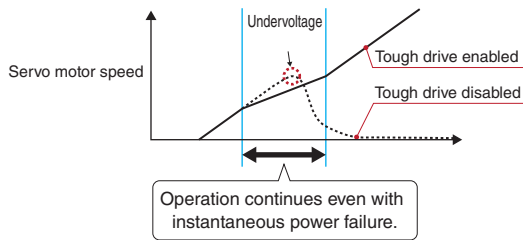

#### Vibration tough drive

Machine resonance suppression filter is automatically readjusted when a change in machine resonance frequency is detected by the servo amplifier, reducing unplanned machine downtime caused by age-related degradation.

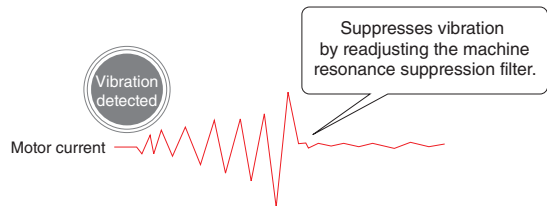

### Large Capacity Drive Recorder

Patented Enhanced functions

- Servo data such as motor current and position command before and after the alarm occurrence are stored in non-volatile memory of the servo amplifier. Reading the servo data on MR Configurator2 helps you analyze the cause of the alarm.
- Check the waveform ((analog 16 bits x 7 channels + digital 8 channels) x 256 points) and the monitor values of the past 16-time alarms in the alarm history.

Data are stored in non-volatile memory at alarm occurrence.

Alarm No. waveform, and monitor value at alarm occurrence are displayed.

Data over certain period of time are continuously stored in the memory.

Lowered bus voltage  
It is revealed that the main circuit power is turned off.

Waveform display

Monitor value display

## Machine Diagnosis Function

Patented

This function detects changes in mechanical parts (ball screw, guide, bearing, belt, etc.) by analyzing changes in machine friction, load moment of inertia, unbalanced torque, and vibration components from the data inside a servo amplifier, supporting timely maintenance of these parts.

[Machine diagnosis function window on MR Configurator2]

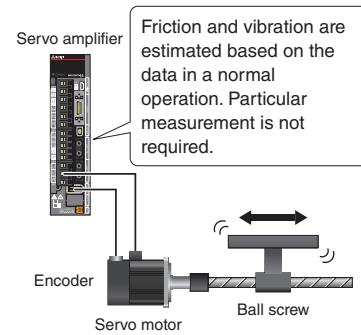
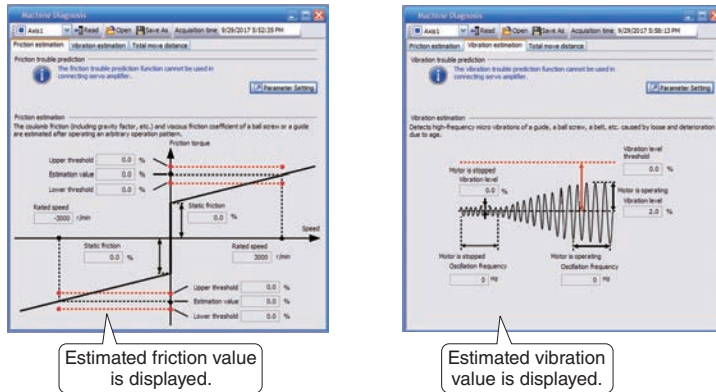

## Three-Digit Alarm

MR-J4 series displays the alarm No. in three digits to show the servo alarm in more details, making troubleshooting easy.

[Three-digit alarm display]



This display is of MR-J4-A.

[Example of an alarm window on MR Configurator2]

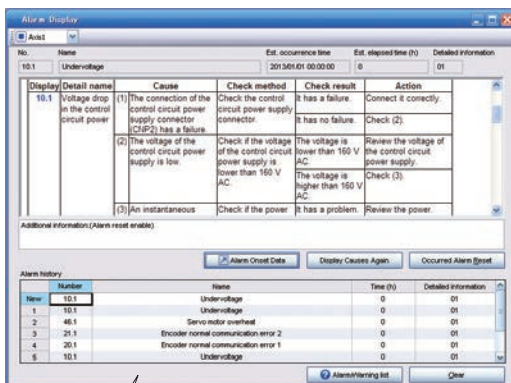

For the undervoltage alarm, whether the alarm occurred in the main or the control circuit is identified by the alarm No.

## Predictive Maintenance

GF

GF-RJ

Patented

MR-J4-GF detects aging-related changes in a machine performance based on the frictions and vibrations monitored by the machine diagnosis function, and informs the maintenance time with a warning. MR-J4-GF also stores the total travel distance of the servo motor and informs the maintenance time with a warning when the total travel distance exceeds the warning limit set by you. When the limit is set to the rated life of a ball screw or bearing, preventive maintenance can be executed according to the actual machine operation.

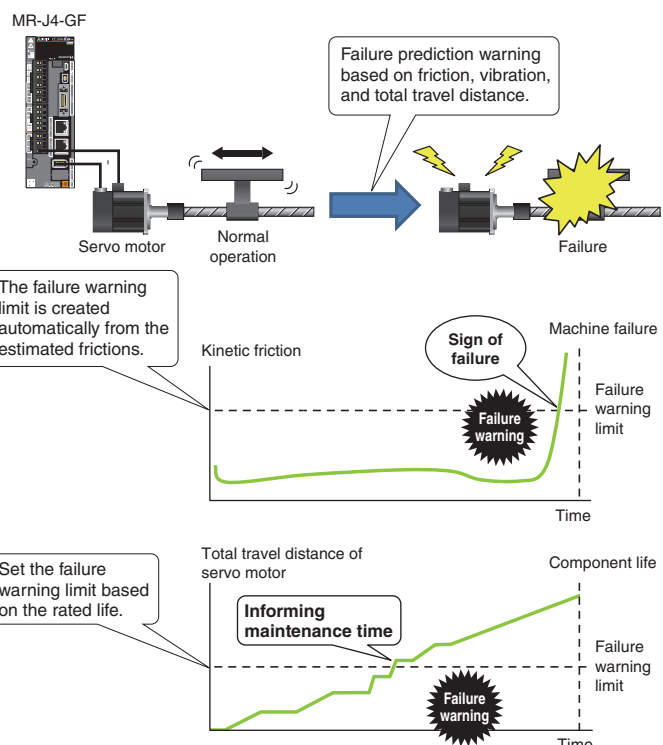

## User-friendly software for easy setup, tuning and operation

Servo engineering software

# MELSOFT MR Configurator2 (SW1DNC-MRC2-E)

Tuning, monitor display, diagnosis, reading/writing parameters, and test operations are easily performed on a personal computer.

This powerful software tool supports a stable machine system and optimum control, and moreover, shortens setup time.

### MELSERIO-J4 | Preparation

#### Servo Assistant Function

Complete setting up the servo amplifier just by following guidance displays. Related functions are called up from the shortcut buttons, making it so easy to set parameters and display alarms.

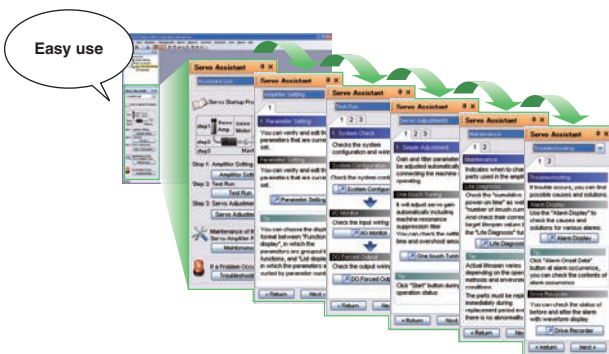

#### Using MR Configurator2 via Controller

Information such as parameter setting and monitoring for the multiple servo amplifiers are consolidated easily just by connecting a personal computer to the PLC CPU or the Motion CPU.

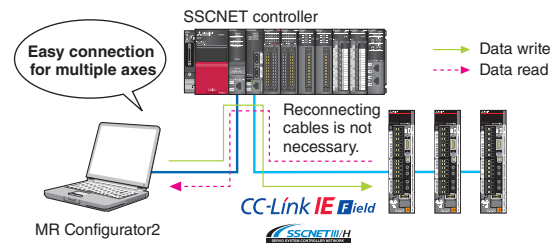

### MELSERIO-J4 | Setting and Startup

#### Parameter Setting Function

Display parameter setting in list or visual formats, and set parameters by selecting from the drop down list. Set in-position range in mechanical system unit (e.g.  $\mu\text{m}$ ). Parameter read/write time is approximately one tenth of that of MR-J3.



#### Monitor Function

Monitor the operation information on the [Display all] window. The power consumption can also be monitored without additional measurement equipment. Assign input/output signals and monitor on/off status of the signals on the "I/O monitor" window.

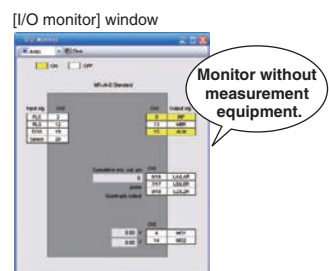
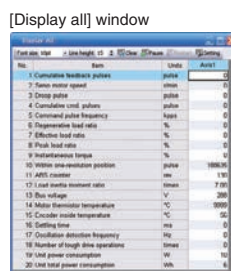

## One-Touch Tuning Function

With the ease of clicking the start button, adjustments including estimating load to motor inertia ratio, adjusting gain, and suppressing machine resonance are automatically performed for the maximum servo performance. Check the adjustment results of settling time and overshoot.

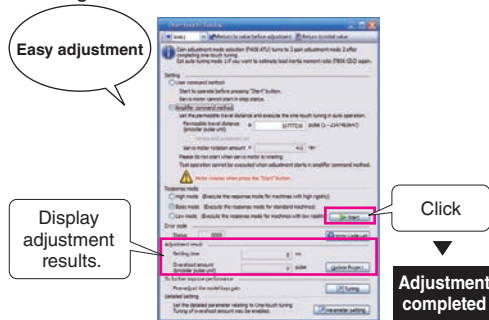

## Tuning Function

Adjust control gain finely on the [Tuning] window manually for further performance after the one-touch tuning.

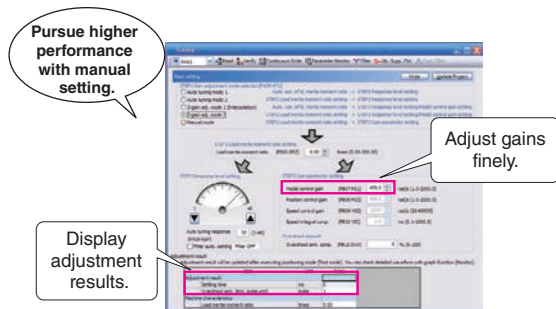

## Graph Function

Enhanced functions

The number of measurement channels is increased to 7 channels for analog and 8 channels for digital. Display various servo statuses in the waveform at one measurement, supporting setting and adjustment. Convenient functions such as [Overwrite] for overwriting multiple data and [Graph history] for displaying graph history are available. Waveform measurement is simultaneously executed on the connected axes via Motion controller communication.



## Machine Analyzer Function

Input random torque to the servo motor automatically and analyze frequency characteristics (0.1 Hz to 4.5 kHz) of a machine system just by clicking the [Start] button. This function supports setting of machine resonance suppression filter, etc.

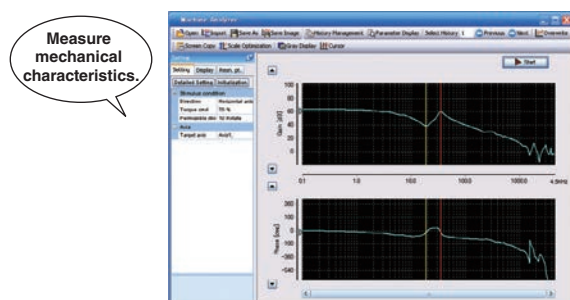

## Servo Amplifier Life Diagnosis Function

Check cumulative operation time and on/off times of inrush relay. This function provides an indication of replacement time for servo amplifier parts such as capacitor and relays.

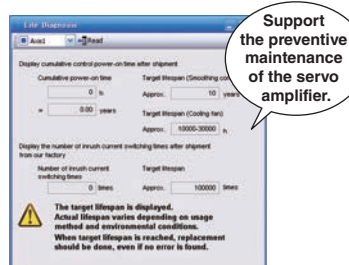

## Machine Diagnosis Function

This function estimates machine friction and vibration in normal operation without special measurements. Comparing the data of the first and after years of operations helps to find out the age-related degradation of a machine, supporting predictive maintenance.

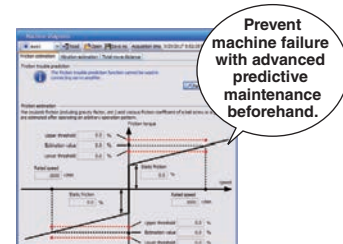

# The Environment



MITSUBISHI SERVO AMPLIFIERS & MOTORS  
**MELSERVO-**

# J4

---

**The new MR-J4 series:**  
**an evolution in eco-friendly design**  
**that's winning acclaim worldwide.**

---

The MR-J4 series was designed with the environment in mind. In addition to helping you reduce your energy consumption, MR-J4 servos have a small footprint and simple wiring requirements that help save space and valuable resources.

Designed to cut waste and save on space, wiring, and energy use

MELSER/0-J4 | Multi-Axis Servo Amplifier in Harmony with Eco-Friendly Society

2-axis/3-axis Types for Energy-Saving and Miniaturized Machine

2-axis and 3-axis servo amplifiers are available for operating two and three servo motors, respectively. These servo amplifiers enable energy-saving, compact machine. Different types of servo motors including rotary servo motors, linear servo motors, and direct drive motors are freely combined as long as the servo motors are compatible with the servo amplifier\*.

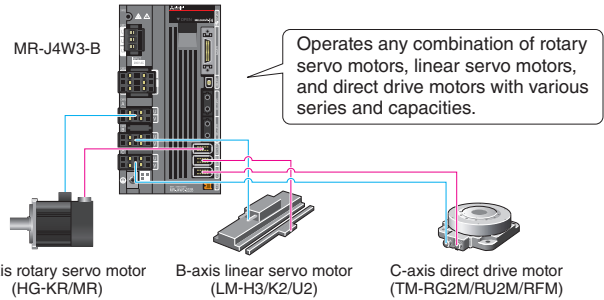

\* For the combination, refer to "Combinations of Multi-Axis Servo Amplifier and Servo Motors" on p. 1-8 in this catalog.

Space-Saving with Industry's Smallest\* 3-axis Type

2-axis servo amplifier MR-J4W2-B requires 26% less installation space than two units of MR-J4-B. 3-axis servo amplifier MR-J4W3-B requires 30% less installation space than three units of MR-J4-B.

[Example of installation space for two units of each 100 W, 200 W, 400 W, and 750 W]

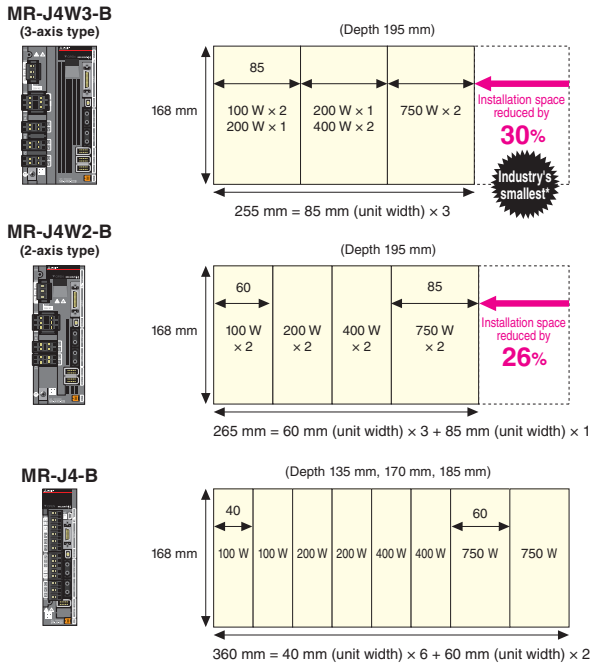

\* Based on Mitsubishi Electric research as of February, 2019

Reduced Wiring by Approx. 50% with 3-axis Type

The three axes of 3-axis servo amplifier MR-J4W3-B use the same connections for main and control circuit power, peripheral equipment, control signal wire, etc. Thus, the number of wirings and devices is greatly reduced.

[Comparison of the number of wirings]

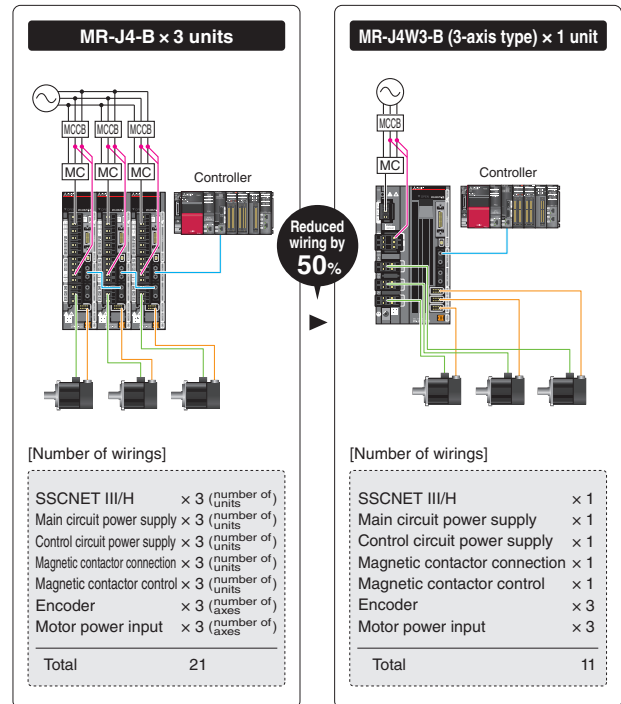

## Eco-friendly performance, designed to save energy in every detail

### MELSERIO-J4 | Optimal Energy-Saving System for Your System

#### System Configuration Examples

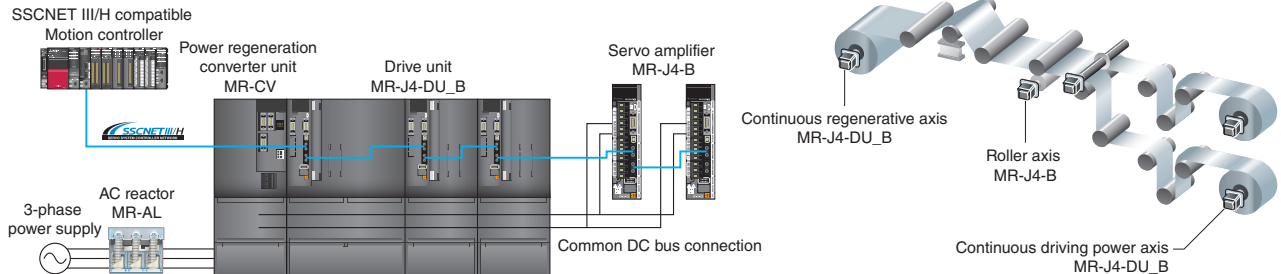

### Energy-Conservation with Common DC Bus Connection

When multiple servo amplifiers and drive units are connected to the MR-CV power regeneration converter unit by a common DC bus connection, the regenerative energy of one axis is used for driving other axes, contributing to energy-conservation. The multi-axis servo amplifier has the same effect.

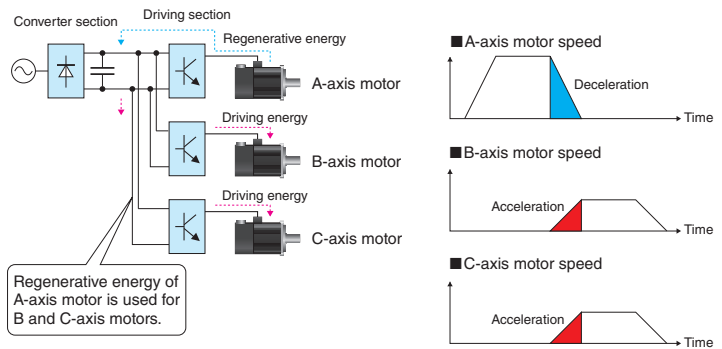

### Further Energy-Conservation with Power Regeneration System

The MR-CV power regeneration converter unit has a power regeneration system which returns the regenerative energy back to the power supply, enabling the regenerative power to be used for other systems for further energy-conservation. In addition, when the MR-CV power regeneration converter unit is used, a regenerative option is not required, and thus, the total heat generation in a system will be decreased.

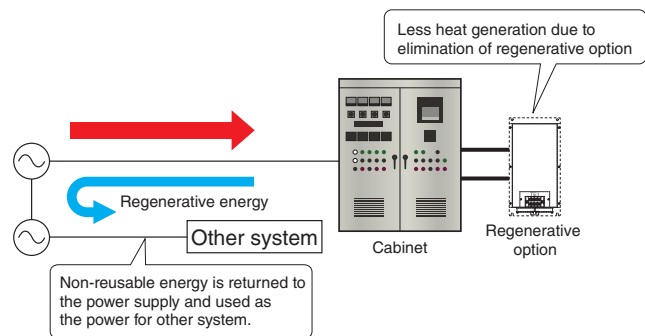

### Advanced Function and Performance for More Energy-Conservation

#### Reduced energy loss of servo amplifier and servo motor

[Servo amplifier]

Efficiency is increased by the use of a new power module.

[Servo motor]

Motor efficiency is increased by optimized design of magnetic circuit.

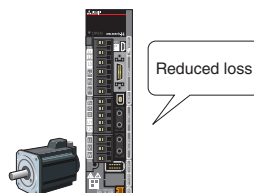

#### Energy-conservation due to the improved machine performance

The servo amplifiers and the servo motors with the industry-leading level of high performance reduce machine cycle time and operation time, resulting in less energy consumption.

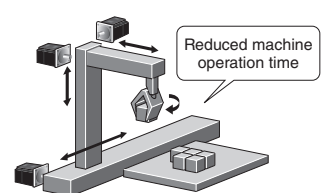



## Power Monitoring Function

Driving power and regenerative power are calculated from the data in the servo amplifier such as speed and current, and the power consumption is monitored with MR Configurator2. In a system of CC-Link IE Field Network or SSCNET III/H, the data are transmitted to a controller, and the power consumption is analyzed and displayed.

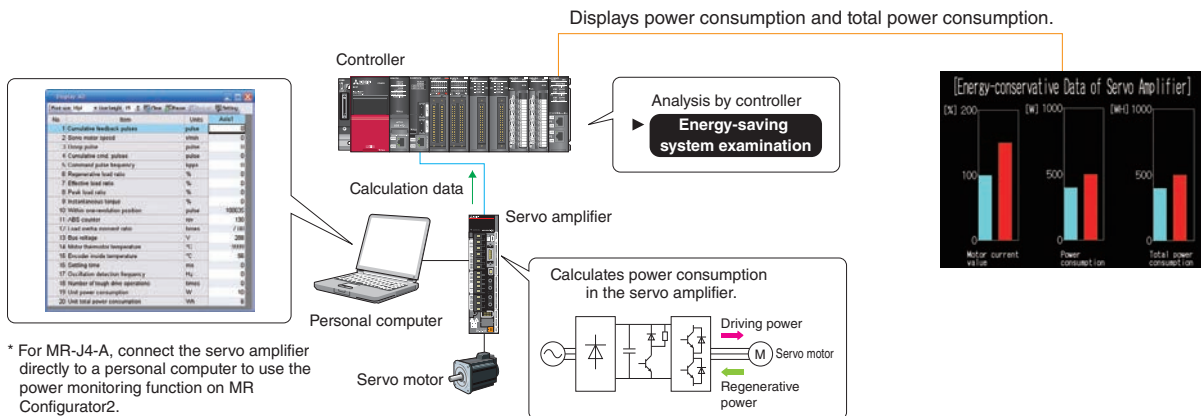

## Energy-Conservation Achieved by LM-H3 Linear Servo Motor Series

### Reduced motor driving power

LM-H3 has achieved a reduction of 25%\* in motor driving current due to a new magnetic design with optimized magnet form, contributing to power conservation for machines. The motor coil is lighter by approximately 12%\* as compared to the prior model, which also contributes to saving energy for driving the moving part. \* For 720 N rated linear servo motor

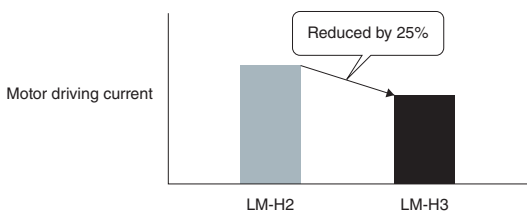

### Space saving

For LM-H3, widths of the motor coil and the magnet are reduced by 10% from the prior model. Increased thrust to current ratio results in using the servo amplifier in smaller capacity, contributing to more compact machine (the reduction of materials).

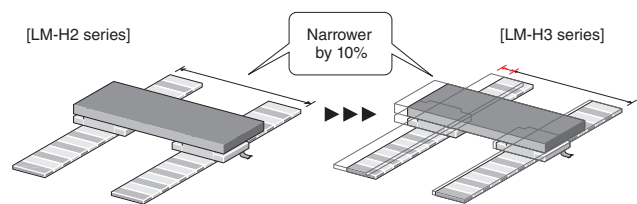

MELSERVO-J4

Environment

## Expanded Environmental Conditions

Capable of operating at an altitude of up to 2000 m.

Compatible with power supply voltage of 240 V AC for global use.

Complies with Restriction of the Use of certain Hazardous Substances in Electrical and Electronic Equipment (RoHS) - Directive

Servo amplifiers with special coating-specification are now available. This servo amplifier has an improved corrosion resistance in environments with corrosive gas concentrations, conforming to IEC 60721-3-3:1994 Class 3C2. For details, contact your local office.

# Heritage



MITSUBISHI SERVO AMPLIFIERS & MOTORS

MELSERVO-

# J4

---

A heritage of trust and  
continuity — the hallmark of  
every MELSERVO product.

---

The MR-J4 series integrates seamlessly with  
your existing manufacturing assets, ensuring  
a smooth transition to the speed and cost  
benefits of leading-edge MELSERVO technology.

# The speed and cost benefits achieved with existing manufacturing assets

## MELSERVO-J4 | Seamless Integration with Existing System

### Easy Replacement of MR-J3 Series

#### Compatible mounting

MR-J4-B/MR-J4-A has the same mounting dimensions\*1 with MR-J3-B/MR-J3-A. HG rotary servo motor series has the same mounting dimensions\*2 and uses the same option cables for the power, the encoder\*3, and the electromagnetic brake as HF series or HC-RP/HC-UP series.

- \*1. Mounting dimensions are smaller for servo amplifiers rated 200 V 5 kW, 400 V 3.5 kW, 200 V/400 V 11 kW, and 200 V/400 V 15 kW.
- \*2. For replacing HA-LP series to HG-JR series, contact your local sales office for more detail.
- \*3. HG-JR series of 11 kW to 55 kW uses a different encoder cable from HF-JP series.

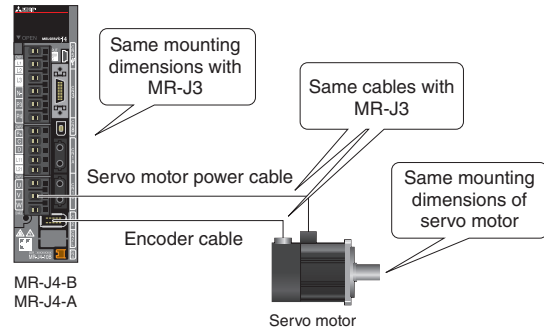

#### When not changing the controller to SSCNET III/H controller

MR-J4-B/MR-J4W2-B/MR-J4W3-B servo amplifier has J3 compatibility mode. By operating in J3 compatibility mode, MR-J4 series servo amplifier and MR-J3 series servo amplifier can be used together in a same system without changing the existing controller.

- \* When the SSCNET III compatible products are in the system, the communication speed is 50 Mbps, and the function and the performance are equivalent to those of MR-J3.
- \* Some functions may not be supported by the J3 compatibility mode. Refer to relevant Servo Amplifier Instruction Manual for details.

The following new functions of MR-J4 series are available with J3 extension function of J3 compatibility mode.

- One-touch tuning function
- Robust filter
- SEMI-F47 function
- Drive recorder function
- Power monitoring function
- Advanced vibration suppression control II
- Machine resonance suppression filter (5 filters)
- Tough drive function
- Machine diagnosis function
- Lost motion compensation function

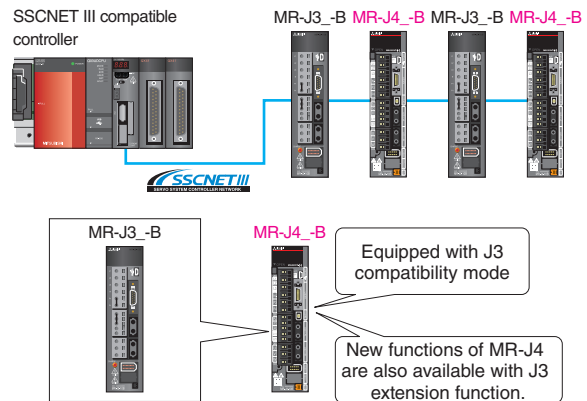

#### Parameter conversion

Parameters are automatically converted by changing MR-J3-B to MR-J4-B with MELSOFT MT Works2\*1. MR-J3-A and MR-J3-T parameters can also be converted to MR-J4-A parameters using the parameter converter function of MR Configurator2\*1.

- \*1. Be sure to update your MT Works2 and MR Configurator2 to the latest version.

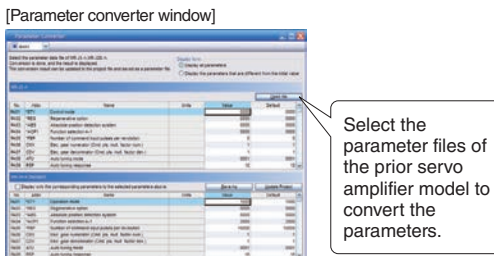

#### Wide variety of product lines

MELSERVO-J3 series is replaceable with MELSERVO-J4 series with a wide variety of power supplies and capacities. MR-J4-B/MR-J4-A is available from 100 W to 55 kW, and the main circuit power supply is selectable from 3-phase 200 V AC, 3-phase 400 V AC and 1-phase 100 V AC.

- \*1. For the product lines, refer to "MELSERVO-J4 Product Lines" on p.5 in this catalog.

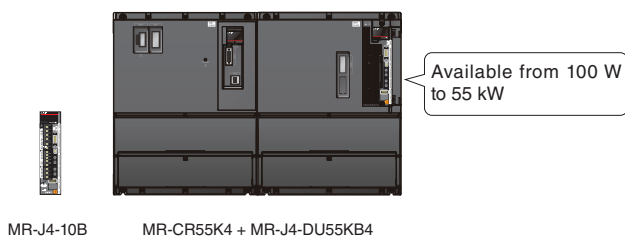

## Supporting Replacement of MR-J2-Super Series

MELSERVO-J4 series product lines include general-purpose interface, positioning function, and SSCNET III/H interface. MELSERVO-J4 series is compatible with a wide variety of command interface and also replaceable from MELSERVO-J2S series.

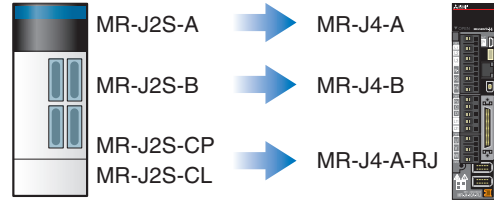

### For renewing the units to MR-J4 series

Parameters are automatically converted with MELSOFT MT Works2\*1 when the servo amplifier is changed from MR-J2S-B to MR-J4-B.

With the parameter converter function of MR Configurator2\*1, parameters of MR-J2S-A are converted to those of MR-J4-A, and parameters of MR-J2S-CP and MR-J2S-CL are converted to those of MR-J4-A-RJ.

\*1. Be sure to update your MT Works2 and MR Configurator2 to the latest version.

[MT Works2 window]

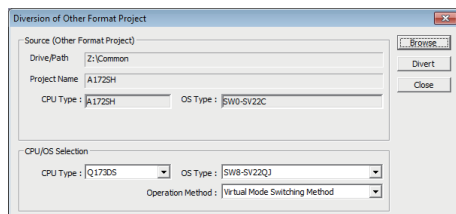

Diversion of other format project window

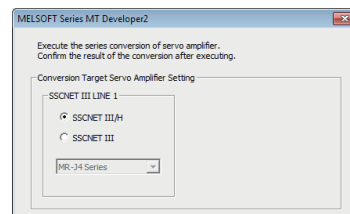
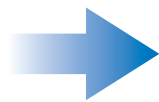

Servo amplifier conversion window

### When not changing the controller to SSCNET III/H controller

A combination of MR-J4-B-RJ020 and MR-J4-T20 conversion unit for SSCNET of MR-J2S-B is capable of connecting to the SSCNET of MR-J2S-B compatible servo system controller.\*

Thus, renewing the units other than the controller to MR-J4 series is possible without changing the existing controller.

\* The function and performance are equivalent to those of MR-J2S-B. (J2S compatibility mode)  
 \* Refer to "New Product Release of Conversion Unit for SSCNET of MR-J2S-B" and "MR-J4-\_B\_-RJ020 MR-J4-T20 Servo Amplifier Instruction Manual" for details.

The set of MR-J4-B-RJ020 and MR-J4-T20 is compatible with the following servo system controllers:  
 A171SHCPU(N), A172SHCPU(N), A173UHCPU, A273UHCPU, A1SD75M, QD75M, Q172CPU(N), and Q173CPU(N)

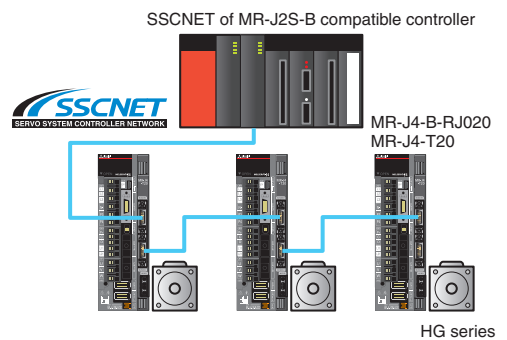

### When using the existing wiring

MR-J2S-B renewal tool manufactured by Mitsubishi Electric System & Service Co., Ltd. is available for using the existing HC/HA series servo motors or for replacing MR-J2S using the existing connections.

This renewal tool enables to use the existing mounting holes and wiring, and the replacement and wiring can be completed in a short period of time.

For MR-J2S renewal tool, contact your local sales office.

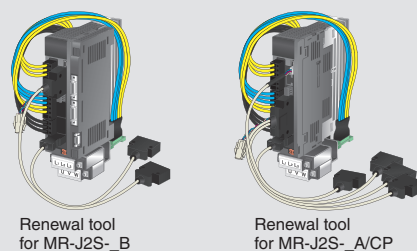

## Renewal related materials

We provide support for the renewal with the following materials from the catalog of renewal introduction, the handbook with detailed information to the instruction manual for the renewal tool to use the existing wiring.



**Transition from MELSERVO-J3/J3W Series to J4 Series Handbook L(NA)03127**  
This handbook explains how to replace your MR-J3/J3W with MR-J4 series.



**MELSERVO-J2-Super Transition Guide catalog L(NA)03091**  
This catalog introduces how to upgrade your MR-J2S to MR-J4 series.



**Transition from MELSERVO-J2-Super/J2M Series to J4 Series Handbook L(NA)03093**  
This handbook explains how to replace your MR-J2S/J2M with MR-J4 series.

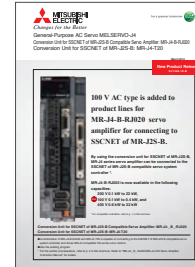

**New Product Release of Conversion Unit for SSCNET of MR-J2S-B SV1306-1**  
This brochure announces a release of MR-J4-B-RJ020 and a conversion unit for connecting to SSCNET of MR-J2S-B. Specifications of the servo amplifier and the conversion unit are also listed.



**MR-J2S Renewal Tool Catalog X901307-312**  
This guide introduces a renewal tool for replacing MR-J2S with MR-J4. The renewal tool allows to use the existing wiring and mounting holes, making the replacement simple and fast.



**Manual for Replacement from MELSERVO-J2S Series Using MR-J2S Renewal Tool X903130707**  
This handbook explains how to replace your MR-J2S with MR-J4, using the renewal tool. Be sure to read through this handbook when considering and implementing the replacement.

Mitsubishi Electric System & Service Co., Ltd.

MR-J2S series has been discontinued since August 2015, and MR-J3/J3W series has been discontinued since May 2019.

## Introducing basic functions from the conventional to the latest

MELSERIO-J4

### Offering Various Basic Functions

#### Position/Speed/Torque control

Position, speed, and torque controls are available. The position control performs positioning by following position commands and is suitable when synchronous or interpolation control is used. Speed and torque are controlled to be constant by the speed and torque controls following the speed and torque commands respectively.

#### Control switching

Control can be switched among position, speed, and torque controls.

\* Control can be switched between two of the controls for MR-J4-A.

#### Real-time auto tuning

The load to motor inertia ratio of a machine is always estimated from the servo motor current and speed during acceleration/deceleration. Therefore, gains such as model loop gain, position loop gain, and speed loop gain are automatically set just by setting the response level.

#### Model adaptive control

Control with high responsivity and high stability is achieved according to the model control.

The two-degrees-of-freedom model adaptive control enables to set the response for command and disturbance respectively.

#### Adaptive filter II

Adaptive filter II is a function in which the servo amplifier detects machine resonance for a predetermined period of time and sets the filter characteristics automatically to suppress mechanical system vibration. Since the filter characteristics (frequency and depth) are set automatically, it is not necessary to consider the resonance frequency of a mechanical system.

This function is effective for the relatively high frequency of machine resonance around 100 Hz to 2.25 kHz.

#### Low-pass filter

The low-pass filter suppresses high-frequency resonance which occurs as servo system response is increased. The filter is enabled as default, and the set frequency is automatically adjusted.

#### Slight vibration suppression control

This function suppresses vibration of  $\pm 1$  pulse produced at a servo motor stop.

#### Gain switching function

This function enables to switch gains. Gains during rotation and during stop can be switched. Using a switching signal to switch gains is also possible during operation.

#### Feed forward

With this function, a position deviation is reduced to nearly zero during constant-velocity operation.

This function improves the tracking of position command during trajectory control, etc.

#### Internal speed command

Up to seven internal speed commands can be stored in parameters. Speed control is possible without using the analog voltage command by selecting the internal speed command with input device.

\* Supported only by MR-J4-A.

#### Absolute position detection system

Merely setting a home position once makes home position return unnecessary at every power-on.

#### Built-in regenerative resistor

Servo amplifiers from 0.2 kW to 7 kW have a built-in regenerative resistor, saving installation space for an option and enabling more compact system.

#### Regenerative option

Use a regenerative option when the built-in regenerative resistor of the servo amplifier does not have sufficient regenerative capability. For 5 kW or larger servo amplifiers, the brake unit is available when the regenerative option does not provide enough regenerative power.

\* Available as an option.

#### Power regeneration converter

Regenerative energy is returned to the power supply and used for other systems, contributing to energy-saving. MR-CV\_ power regeneration converter unit is compatible with MR-J4-DU\_B\_(-RJ) drive unit and MR-J4-\_B\_(-RJ) servo amplifier. FR-XC multifunction regeneration converter unit is compatible with the servo amplifiers of 100 W to 22 kW in 200 V class and 0.6 kW to 22 kW in 400 V class.

Some functions may not be available depending on the models.  
Refer to relevant Servo Amplifier Instruction Manual for details.

### Dynamic brake

The dynamic brake is designed to decelerate the servo motor immediately at an alarm occurrence, power failure, or forced stop. The dynamic brake is not for holding a shaft at a stop.

- \* The dynamic brake is built in the 7 kW or smaller servo amplifiers.
- \* The external dynamic brake is required for the 9 kW or larger servo amplifiers.

### Close mounting

Close mounting is possible for 200 V 3.5 kW or smaller, 100 V, and 48 V DC/24 V DC servo amplifiers. Mounting space efficiency is significantly improved.

- \* When the servo amplifiers are closely mounted, the operation environment condition is different.
- \* Close mounting is not possible when the servo amplifiers of 1 kW and 2 kW in 200 V class are used with 1-phase power supply.

### Input signal selection (device settings)

Function assigned to each pin for digital input can be changed by setting parameters.

- \* Available with MR-J4-GF and MR-J4-A.

### Output signal selection (device settings)

Function assigned to each pin for digital output can be changed by setting parameters.

### Encoder output pulse

Encoder output pulses can be outputted in the differential line driver type as A/B/Z-phase pulse. Output pulse per servo motor revolution can be set with the parameter.

- \* MR-J4W2-B outputs A/B-phase pulse. MR-J4W3-B is not compatible with this function.

### A/B-phase pulse through output

With this function, when an A/B/Z-phase differential output type linear encoder is used, A/B/Z-phase signals from the linear encoder are outputted as encoder output pulses. The signals from the linear encoder are used by a controller without being branched.

- \* Available only with MR-J4-GF-RJ/MR-J4-B-RJ/MR-J4-A-RJ.

### Monitoring (Status display)

Servo status such as regenerative load ratio, effective load ratio, instantaneous torque, or servo motor speed can be monitored on MR Configurator2. For MR-J4-A, the status is also confirmed on the seven-segment LED display.

### Analog monitor output

Servo status such as torque and servo motor speed is outputted in terms of voltage in real time.

- \* Not available with MR-J4W2-B/MR-J4-W3-B.

### Alarm history

The past 16 alarms are recorded in the servo amplifier. The alarms can be checked in a list with MR Configurator2.

### Test operation

Before starting actual operation, perform test operation to make sure that the machine operates normally. The following can be performed using MR Configurator2.

- JOG operation  
Test operation function for checking a speed control operation without a command from a controller.
- Positioning operation  
Test operation function for checking a positioning operation by position control without a command from a controller.
- Motor-less operation  
Without connecting a servo motor, this function outputs signals in response to the input device and displays status as if the servo motor is actually running. The motor-less operation is useful for checking the sequence of controller, etc.
- Program operation  
Without using a controller, this function enables positioning operation consisting of multiple simple operation patterns.
- Output signal (DO) forced output  
This function switches output signals on/off forcibly independently of the servo status, useful for checking the output signal wirings.

### Multi-axis adjustment function

This function simultaneously adjusts parallel drive axes which make the same motion and also executes test operation and gain adjustment for up to four axes at the same time. The target axes can be selected with a simple operation on engineering software.

- \* This function is available when the servo amplifier is used with RnMTCPU or RD77MS.

### Pressure control function

Pressure sensor signals are directly inputted to the servo amplifier, enabling high-response feedback control and pressure control.

- \* Pressure control-compatible servo amplifier (MR-J4-B-LL) is necessary.

Some functions may not be available depending on the models.  
Refer to relevant Servo Amplifier Instruction Manual for details.

## A wide-ranging lineup to meet virtually every drive control need

The new MR-J4 series lineup includes servo amplifiers and servo motors to meet virtually every production need — because every production site is different, with unique problems that require unique and innovative solutions.



2-axis and 3-axis types are available for your system.

**Servo amplifier**



### MR-J4-GF(-RJ)

The CC-Link IE Field Network compatible servo amplifier enables a system synchronized with remote I/O with Ethernet-based open network.



### MR-J4-B(-RJ)

With the SSCNET III/H compatible servo amplifier, a complete synchronous system can be configured using high-speed serial optical communication. Servo system performance and functions are utilized to the fullest when MR-J4-B(-RJ) is used combined with the servo system controller.

#### Product lines

Servo amplifiers with CC-Link IE Field Network, SSCNET III/H, and general-purpose interface are available.

Model	Power supply	Command interface	Fully closed loop control*2	Compatible servo motor		
				Rotary	Linear*3	Direct drive
MR-J4-GF(-RJ)*1	1-phase 100 V AC	CC-Link IE Field Network	●	●	●	●
	3-phase 200 V AC		●	●	●	
	3-phase 400 V AC		●	●	—	
MR-J4-B(-RJ)*1	1-phase 100 V AC	SSCNET III/H	●	●	●	●
	3-phase 200 V AC		●	●	●	
	3-phase 400 V AC		●	●	—	
MR-J4W2-B	3-phase 200 V AC 2-axis	SSCNET III/H	●	●	●	●
	48 V DC/24 V DC 2-axis		—	—	—	
MR-J4W3-B	3-phase 200 V AC 3-axis	SSCNET III/H	—	●	●	●
MR-J4-A(-RJ)*1	1-phase 100 V AC	Pulse train/ Analog voltage/ RS-422/RS-485*5 MODBUS® RTU*4	●	●	●	●
	3-phase 200 V AC		●	●	●	
	3-phase 400 V AC		●	●	—	
	48 V DC/24 V DC		—	—	—	

\*1. MR-J4-GF-RJ/B-RJ/A-RJ servo amplifier is compatible with two-wire and four-wire type serial, and pulse train interface (A/B/Z-phase differential output type) linear encoders. (MR-J4-03A6-RJ is not compatible with the linear encoders.)

\*2. MR-J4-GF/B/A servo amplifier is compatible only with two-wire type serial linear encoder. For four-wire type serial and pulse train interface (A/B/Z-phase differential output type) linear encoders, use MR-J4-GF-RJ/B-RJ/A-RJ.

\*3. MR-J4-GF/B/A servo amplifier is compatible only with two-wire type and four-wire type serial linear encoders. For pulse train interface (A/B/Z-phase differential output type) linear encoder, use MR-J4-GF-RJ/B-RJ/A-RJ.





## MR-J4W2-B

The SSCNET III/H compatible 2-axis servo amplifier drives two servo motors, enabling energy-saving, less-wiring, compact machine.



## MR-J4W3-B

The SSCNET III/H compatible 3-axis servo amplifier drives three servo motors, enabling energy-saving, less-wiring, compact machine.



## MR-J4-A(-RJ)

The general-purpose interface compatible servo amplifier enables position control by pulse train command and speed/torque control by analog voltage command. The maximum command pulse frequency is 4 Mpulses/s.

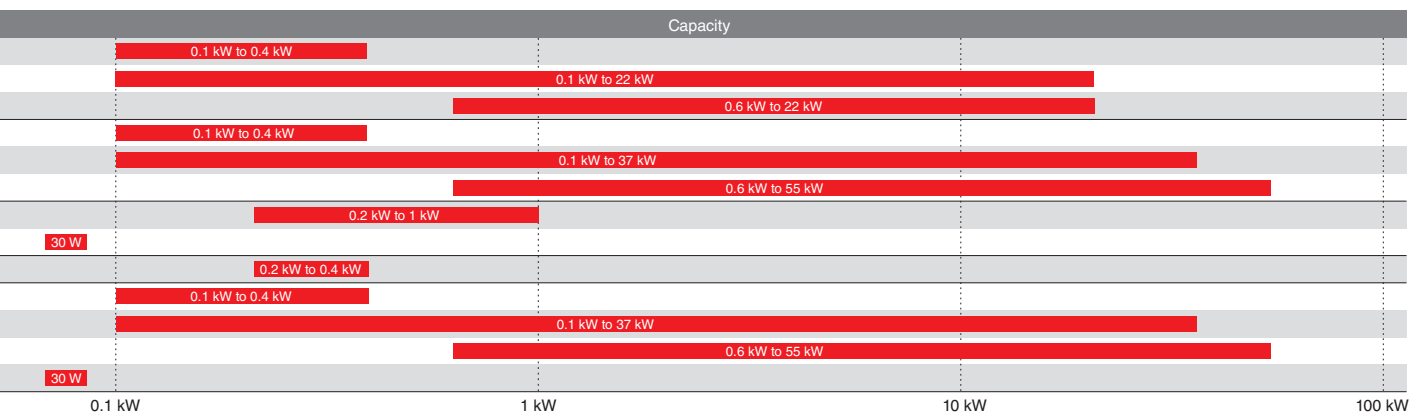

\*4. MODBUS® RTU is supported only by MR-J4-A-RJ. (Not supported by MR-J4-03A6-RJ).  
 \*5. RS-485 is supported only by MR-J4-A(-RJ). (Not supported by MR-J4-03A6-RJ).

High-speed, high-torque servo motors for fast, precise machine operation



### HG-KR Series HG-MR Series

Rated speed: 3000 r/min  
Maximum speed: 6000 r/min  
Maximum torque is 350%\* of the rated torque, and high torque is achieved during high-speed. \* Supported only by HG-KR.



### HG-SR Series

This medium capacity, medium inertia servo motor enables stable operation. The motor has achieved the industry's shortest class in length by the structural design being optimized.



### HG-JR Series

This medium/large/ultra-large capacity, low inertia servo motor is suitable for high-throughput and high-acceleration/deceleration operations.



### HG-AK Series

The ultra-compact servo motor with the flange size of 25 mm × 25 mm is suitable for small machines and machine heads.



### HG-RR Series

This medium capacity, ultra-low inertia servo motor is perfect for high-throughput operations.



### HG-UR Series

This medium capacity, flat type servo motor is well suited for situations where the installation space is limited.

## Product Lines

A wide range of series and capacities is available.

Series	Inertia Type	Voltage	Power Range
HG-KR series	Low inertia	200 V AC	50 W to 750 W
HG-MR series	Ultra-low inertia	200 V AC	50 W to 750 W
HG-SR series	Medium inertia	200 V AC	0.5 kW to 7 kW
		400 V AC	0.5 kW to 7 kW
HG-JR series	Low inertia	200 V AC	0.5 kW to 37 kW
		400 V AC	0.5 kW to 220 kW
HG-AK series	Ultra-compact	48/24 V DC	10 W to 30 W
HG-RR series	Ultra-low inertia	200 V AC	1 kW to 5 kW
HG-UR series	Flat type	200 V AC	0.75 kW to 5 kW

## Equipped with High-Resolution Absolute Position Encoder

Servo motors are equipped with a high-resolution absolute position encoder of 4,194,304 pulses/rev (22-bit) as standard. Positioning accuracy is increased.  
 \* 262,144 pulses/rev (18-bit) for HG-AK series.

## Improved Environmental Resistance

Ingress protection<sup>\*2</sup> of servo motors:  
 HG-KR/HG-MR/HG-RR/HG-UR: IP65  
 HG-SR/HG-JR: IP67<sup>\*1</sup>  
 HG-AK: IP55



<sup>\*1</sup> HG-JR 1000 r/min series 15 kW or larger, HG-JR 1500 r/min series 22 kW or larger, and HG-JR 2000 r/min series are rated IP44.  
<sup>\*2</sup> The shaft-through portion is excluded.

## Reduced Torque Ripple during Conduction

The torque ripple is reduced owing to the optimized combination of the numbers of the motor poles and the slots. Thereby, smooth rotation is achieved even during a low-speed operation which is more likely affected by the torque ripple, improving the operation stability.

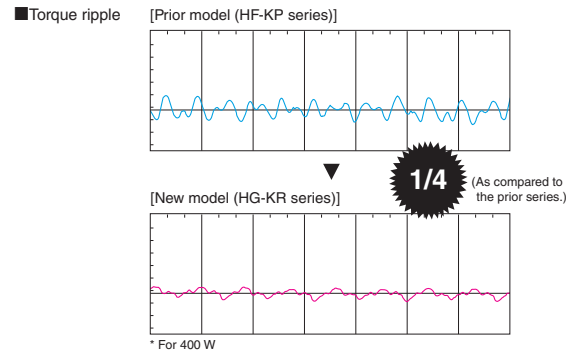

## Cable Leading Direction

Cables for power, encoder, and electromagnetic brake are capable of being connected either in direction or in opposite direction of the load side, depending on the cable selection. (HG-KR and HG-MR series)

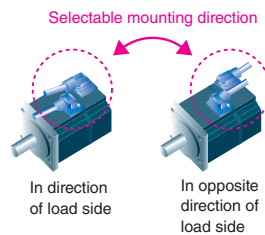

## Application Examples

For various applications of every kinds of machine.

Semiconductor/FPD/photovoltaic manufacturing systems 	Mounters/bonders 	X-Y tables 	Robots 
Loaders/unloaders, feeders and sliders 	Food processing machines (filling machine, mixer, measuring machine, etc.) 	Food packaging machines 	Press machines 

## Servo motors for high-speed, high-accuracy, linear drive systems



Linear servo motor  
**LM** Series

### Sophisticated Performance

- Maximum speed: 3 m/s (LM-H3 series)
- Maximum thrust range: 150 N to 18000 N  
Small size and high thrust are achieved by the increased winding density and the optimized core and magnet geometries as a result of electromagnetic field analysis.
- Four series are available: core, liquid-cooling core, magnetic attraction counter-force core, and coreless types.
- The linear servo motors are compatible with a variety of serial interface linear encoders including A/B/Z-phase differential output type linear encoders\*. The linear encoder resolution ranges from 1 nm and up.  
\* A/B/Z-phase differential output type linear encoder is compatible with MR-J4-GF-RJ/MR-J4-B-RJ/MR-J4-A-RJ servo amplifier.
- High-performance systems such as high-accuracy tandem synchronous control are achieved using MR-J4 series servo amplifier with CC-Link IE Field Network or SSCNET III/H compatible controller.

### Achieving High-Performance Machine

#### For higher machine performance

- Improved productivity due to high-speed driving part.
- High-accuracy positioning by fully closed loop control system.

#### For easier use

- The linear servo motor enables simple and compact machine with high rigidity.
- Smooth operation and clean system are achieved.

#### For flexible machine configurations

- Multi-head and tandem systems are easily configured.
- The linear servo motor is suitable for long-stroke applications.

[Offers more advantage than conventional ball screw driving systems]

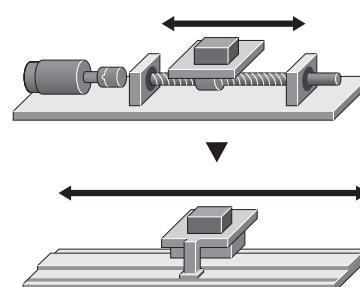

## Product Lines

Four series are available depending on applications.

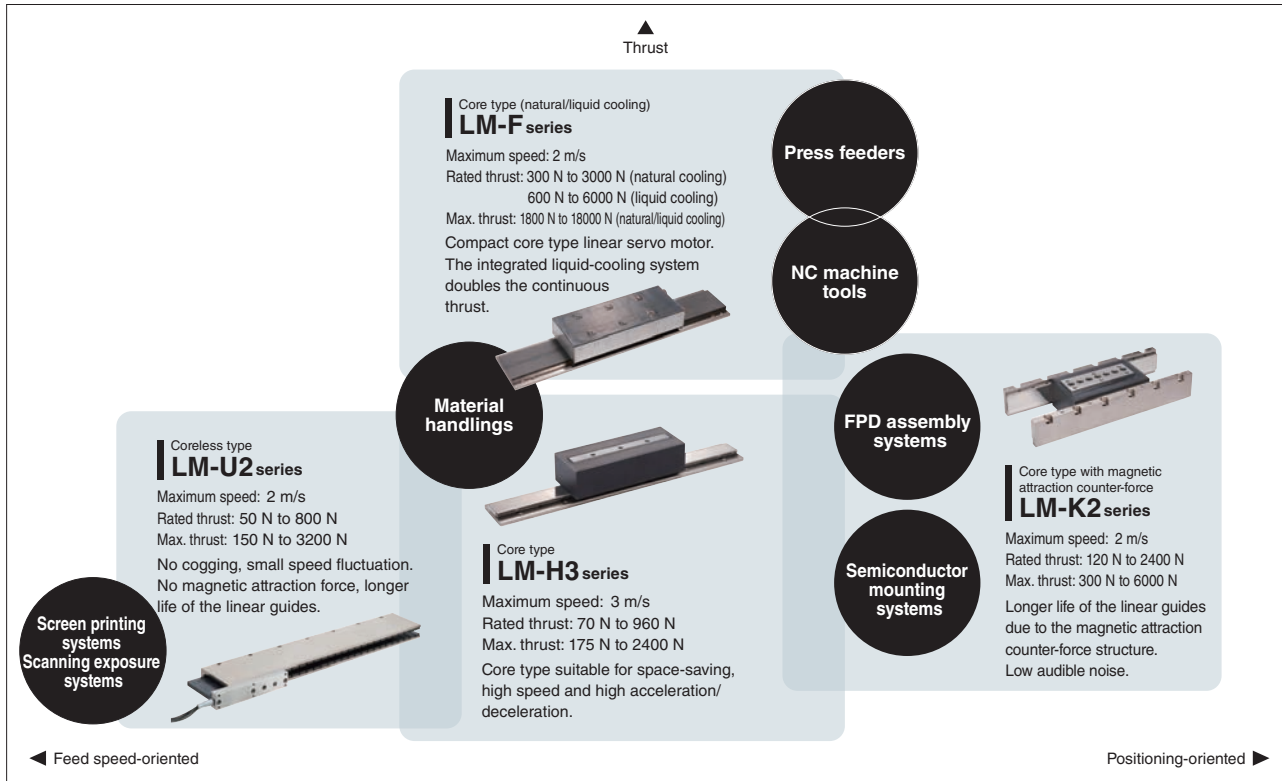

## Application Examples

Optimum for a linear drive system which requires a high speed and high accuracy. Easily achieve a tandem configuration or multi-head configuration.

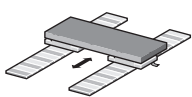

### Tandem configuration

The linear servo motors configured in tandem are suitable for large systems that require highly accurate synchronous operation between two axes.

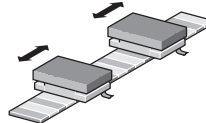

### Multi-head configuration

Multi-head systems enable control of two motor coils independently, thereby simplifying machine mechanisms. This system is suitable for machines that require short cycle time.

Machine tools XYZ stage

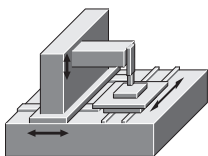

Semiconductor/FPD manufacturing systems  
Electrical parts assembling/manufacturing systems

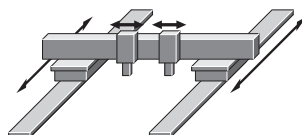

Screen printing systems and large FPD coaters

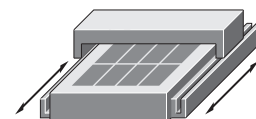

Material handling systems



Multi-head material handling between machines

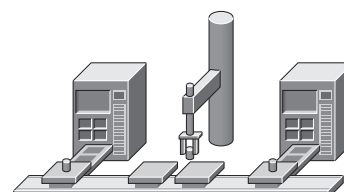

## Compact and robust direct drive motors for high-accuracy applications



### Sophisticated Performance

#### High performance with the latest technologies

Our latest magnetic design and winding technologies enable high torque density. In addition, extremely smooth rotation is achieved by the minimized torque ripple.

#### High-resolution absolute position encoder

The direct drive motor is equipped with a high-resolution absolute position encoder (1,000,000 to 4,000,000 pulses/rev) as standard. High-accuracy machine is achieved.

#### Compact and low-profile design

Due to high level of structural design technology, compact and low-profile design is achieved. This design enables a small mounting space and a low center of gravity.

#### Hollow shaft diameter range: $\varnothing 20$ mm to 104 mm

The motor is equipped with a large hollow shaft resulting from using bearing and encoder with large diameter. It allows cables and air tubing to pass through.

### Achieving High-Performance Machine

#### For higher machine performance

- Suitable for low-speed and high-torque operations.
- High-accuracy positioning is achieved because the motor is directly coupled to a load.

#### For easier use

- Since mechanical transmission is no longer required, no backlash and no abrasion occurs, enabling smooth operation with less audible noise, clean system, and easy maintenance.
- Less components are required for the system.

#### For flexible machine configurations

- Simple, compact, and high-rigid machine is achieved.
- Machine stability is enhanced due to the low-profile design and a low center of gravity.
- The motor has an inner rotor with hollow shaft that allows cables and pipes to pass through.

[No mechanical transmission contributing to no warp or distortion.]

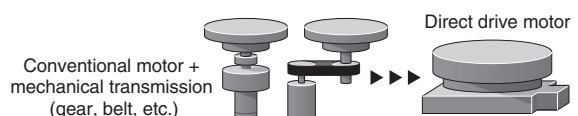

## Product Lines

18 models with 4 different diameters are available.

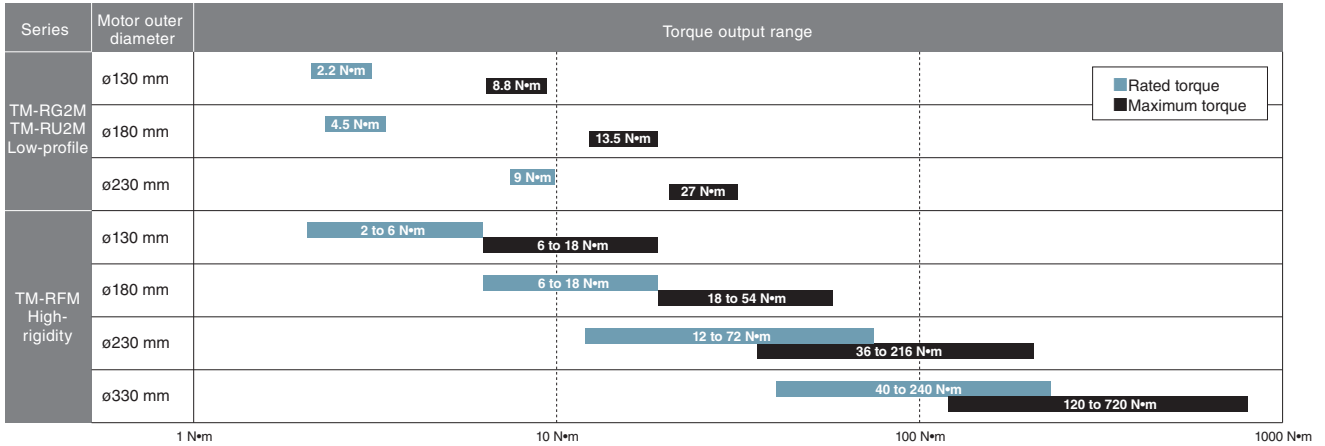

## Application Examples

Suitable for low speed and high torque applications.

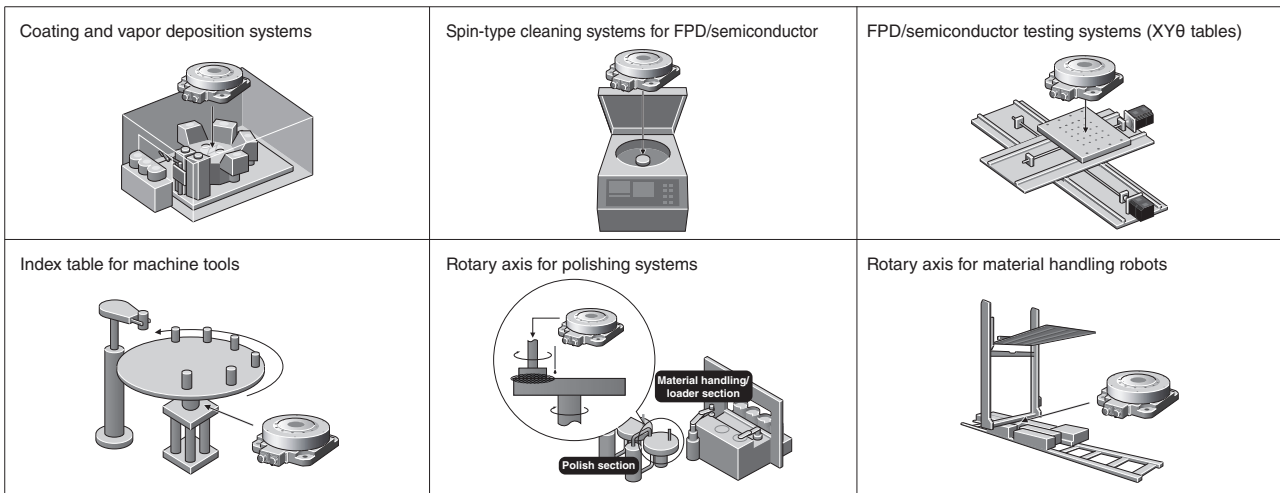

MELSER/6-J4

## Drive System Sizing Software MELSOFT Motorizer

Select the most suitable servo motors, servo amplifiers, and regenerative options for your machine just by setting machine specifications and operation patterns. You can select a suitable combination from various results. This software also supports multi-axis systems, enabling you to set operation patterns and select options for multiple axes.

Specification input

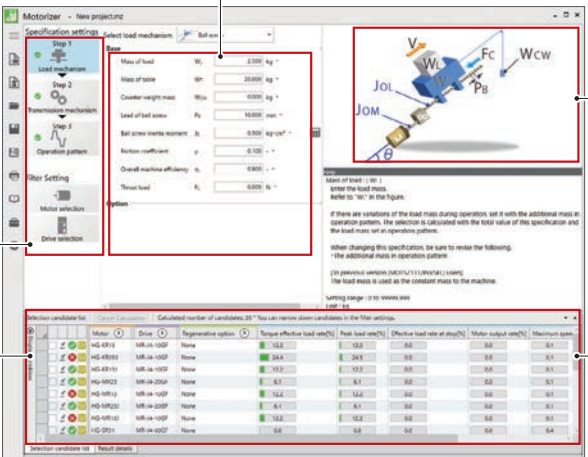

Navigation

The selection result displays various possible options.

- 13 common load mechanisms
- Able to add mechanical transmissions

The selection result can be read by FA Integrated Selection Tool.

# Simple Motion Module



**CC-Link IE Field**

CC-Link IE Field Network compatible Simple Motion module

**RD77GF  
QD77GF**

**SSCNET III/H**

SSCNET III/H compatible Simple Motion module

**RD77MS  
QD77MS  
LD77MS  
FX5-SSC-S**

Select from two types of network: Ethernet-based open network (CC-Link IE Field Network) or optical network (SSCNET III/H).

## Features of Simple Motion Module

The Simple Motion module is an intelligent function module which performs positioning control by following the instructions of PLC CPU.

- The positioning functions are used in the same manner as those of the Positioning module.
- Linear interpolation control and other controls can be achieved easily just by writing positioning data from sequence programs to the buffer memory.
- Positioning/synchronous/cam controls are performed with simple parameter setting and a start from a sequence program.

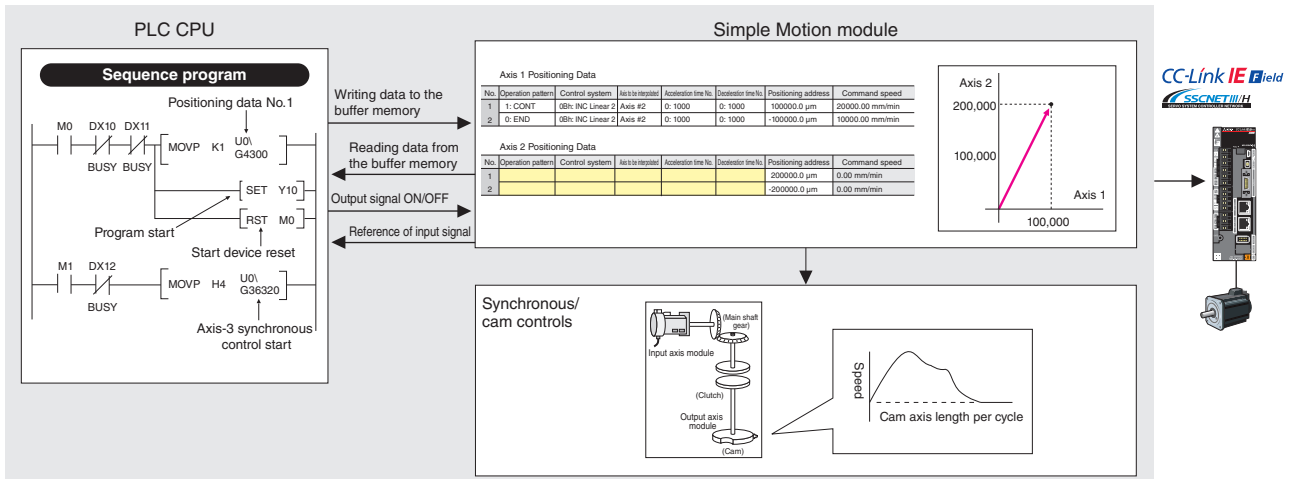

	RD77GFn	QD77GFn	RD77MSn	QD77MSn	LD77MSn	FX5-SSC-S
Max. number of control axes	n = 4/8/16/32 axes	n = 4/8/16 axes	n = 2/4/8/16 axes	n = 2/4/16 axes		4/8
Operation cycle	0.5 ms or longer	1.0 ms or longer	0.444 ms or longer		0.888 ms or longer	1.777 ms
Programming language	—					
Control mode	Position control	Speed control	Torque control	Tightening & press-fit control*1	Advanced synchronous control	Cam control
Positioning control	Linear interpolation	Circular interpolation	Continuous trajectory control	Helical interpolation*2		Speed/position switching control (ABS)
Auxiliary function	Forced stop	Hardware stroke limit	Software stroke limit	Absolute position system	Amplifier-less operation	Unlimited length feed
	Optional data monitor	Mark detection	Flash ROM backup	M-code output	Error history	Digital oscilloscope
			Cam auto-generation			

\*1. Not supported by RD77GF/QD77GF.

\*2. Not supported by QD77GF/QD77MS/LD77MS/FX5-SSC-S.



# Motion Controller



SSCNET III/H compatible  
Motion controller

R16MTCPU  
R32MTCPU  
R64MTCPU  
Q172DSCPU  
Q173DSCPU



SSCNET III/H compatible  
Stand-Alone Motion controller

Q170MSCPU  
Q170MSCPU-S1

- Multiple CPU system with PLC CPU
- Integrates a power supply, a programmable controller, and a Motion controller
- Equipped with an incremental synchronous encoder interface and the mark detection function

## Features of Motion Controller

The Motion controller is a CPU module used with PLC CPU for Motion control.

- Using Motion SFC programs, the Motion CPU separately operates controls from the PLC CPU. Thus CPU loads are distributed, achieving advanced Motion control.
- Various advanced Motion controls, such as tightening & press-fit, advanced synchronous, and cam controls can be performed in addition to basic controls including positioning, speed and torque controls.
- COGNEX vision system can be directly connected to the controller via Ethernet.

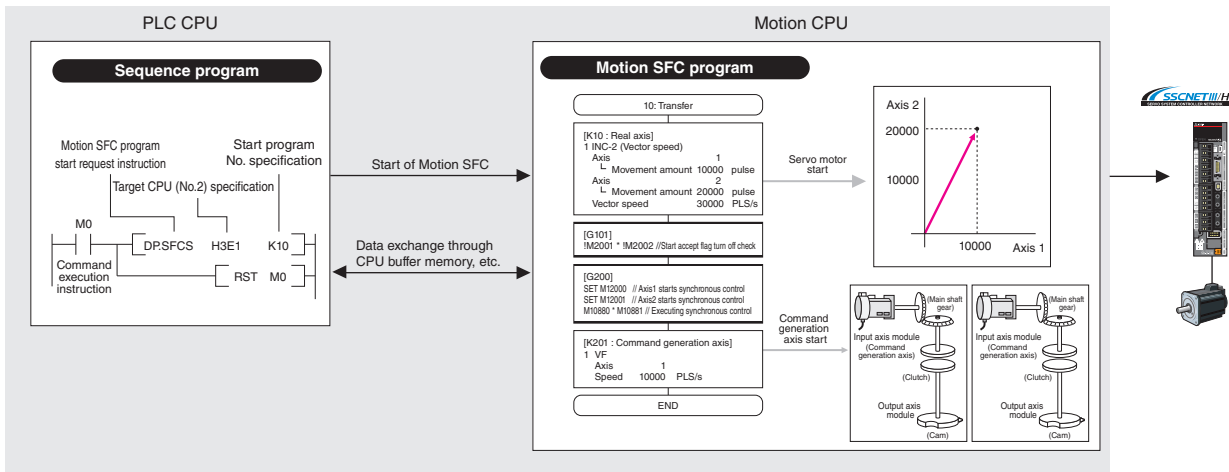

	R64MTCPU	R32MTCPU/Q173DSCPU	R16MTCPU/Q172DSCPU	Q170MSCPU-S1	Q170MSCPU
Max. number of control axes	64 axes	32 axes		16 axes	
Operation cycle	0.222 ms or longer			0.222 ms or longer	Equivalent to Q06UDH
Programming language	Motion SFC				
Control mode	Position control Pressure control*1	Speed control	Torque control	Tightening & press-fit control	Advanced synchronous control Cam control
Positioning control	Linear interpolation High-speed oscillation control	Circular interpolation Speed/position switching control	Continuous trajectory control	Helical interpolation	Position follow-up control Speed control with fixed position stop
Auxiliary function	Forced stop Optional data monitor Vision system connection	Hardware stroke limit Mark detection Software security key	Software stroke limit ROM operation Cam auto-generation	Absolute position system M-code output High-speed reading	Amplifier-less operation Error history Limit switch output

\*1. Not supported by Q170MSCPU(-S1)

## Positioning Module

The Positioning module is an intelligent function module which performs positioning control easily by following the instructions of PLC CPU. The Positioning module is compatible with the general-purpose pulse train as the command I/F and is used with MR-J4-A.



Pulse train compatible  
MELSEC iQ-R series  
**RD75P2, RD75D2**  
**RD75P4, RD75D4**

- Maximum number of control axes:  
2 axes (RD75P2/RD75D2) and 4 axes (RD75P4/RD75D4)
- Open-collector type or differential line driver type is selectable for pulse train output
- Equipped with various positioning functions, such as circular interpolation and target position change function



Pulse train compatible  
MELSEC-Q series  
**QD75P1N, QD75D1N**  
**QD75P2N, QD75D2N**  
**QD75P4N, QD75D4N**

- Maximum number of control axes:  
1 axis (QD75P1N/QD75D1N), 2 axes (QD75P2N/QD75D2N), and 4 axes (QD75P4N/QD75D4N)
- Open-collector type or differential line driver type is selectable for pulse train output
- Equipped with various positioning functions, such as circular interpolation and target position change function



Pulse train compatible  
MELSEC-L series  
**LD75P1, LD75D1**  
**LD75P2, LD75D2**  
**LD75P4, LD75D4**

- Maximum number of control axes:  
1 axis (LD75P1/LD75D1), 2 axes (LD75P2/LD75D2), and 4 axes (LD75P4/LD75D4)
- Open-collector type or differential line driver type is selectable for pulse train output
- Equipped with various positioning functions, such as circular interpolation and target position change function



Pulse train compatible  
MELSEC-L series  
**L02SCPU, L02CPU**  
**L02CPU-P, L06CPU**  
**L26CPU, L26CPU-BT**  
**L26CPU-PBT**

- Maximum number of control axes: 2 axes
- Supports S-curve acceleration/deceleration
- Equipped with various functions as standard, such as positioning, high-speed counter, pulse catch, interrupt input, and general input/output functions



Pulse train compatible  
MELSEC iQ-F series  
**FX5-20PG-P**  
**FX5-20PG-D**  
**FX5 CPU module**

- [FX5-20PG-P/FX5-20PG-D]
- Maximum number of control axes: 2 axes
  - Open-collector type or differential line driver type is selectable for pulse train output
- [FX5 CPU module]
- Maximum number of control axes: 3 axes (FX5UJ), 4 axes (FX5U, FX5UC, FX5S)
  - Equipped with built-in positioning functions, pulse train output is possible



Pulse train compatible  
MELSEC-F series  
**FX3U-1PG**  
**FX3 basic module**

- [FX3U-1PG]
- Maximum number of control axes: 1 axis
  - Up to 200 kHz pulse output is possible
- [FX3 basic module]
- Maximum number of control axes:  
2 axes (FX3G (14-point and 24-point type), FX3GC, FX3S),  
3 axes (FX3U, FX3UC, FX3G (40-point and 60-point type))
  - Equipped with built-in positioning functions, pulse train output is possible

# C Controller/Personal Computer Embedded Type Servo System Controller

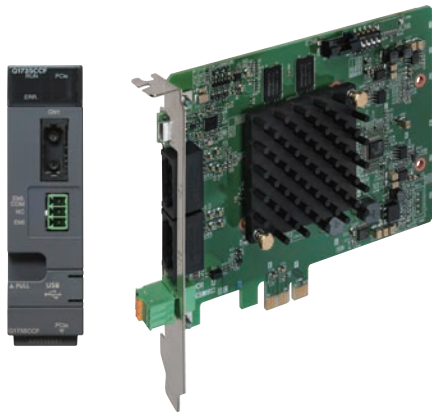

C Controller Interface Module

## Q173SCCF

Connected directly to a C Controller via PCI Express®, this module is used for controlling MR-J4\_-B, by a user program.

- High-speed access by PCI Express® and detection of interrupts.
- Event-driven programs, which use interrupts, can be created.

SSCNET III/H compatible Position Board

## MR-MC210/211 MR-MC220U3/220U6 MR-MC240/241/341

CC-Link IE Field compatible Simple Motion Board

## MR-EM340GF

Connected to a personal computer, this board type controller is used for controlling MR-J4-B/MR-J4-GF.

- Event-driven programs, which use interrupts, can be created.
- Supporting the real-time OS.

## Features of C Controller/Personal Computer Embedded Type Servo System Controller

- Select a C Controller or a personal computer for the system.
- Programmable controllers are not required in the system
- Equipped with Point to Point positioning functionality as standard (set with Point table)
- High-speed processing (For SSCNET III/H: 1 cycle startup, 0.222 ms/8 axes)
- Various API functions and a test tool help users develop applications

### ● C Controller Interface Module system configuration

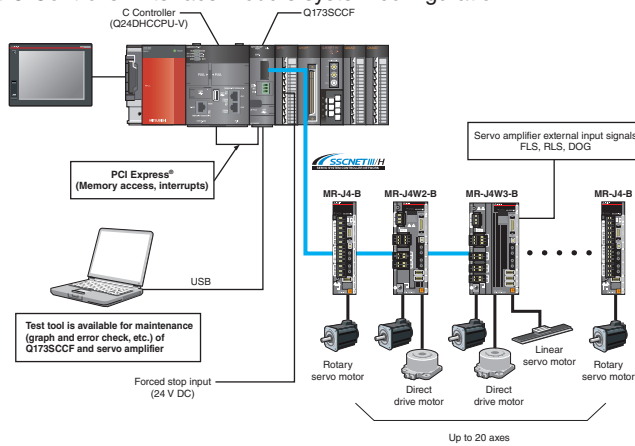

### ● Position Board system configuration

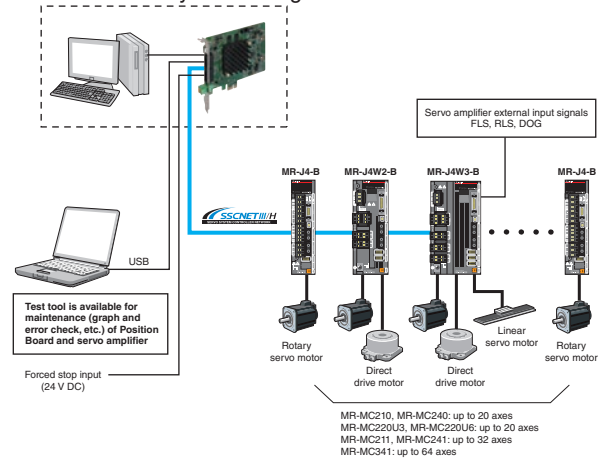

### ● Main basic functions

JOG operation, Incremental feed, Automatic operation, Linear interpolation, Home position return, Electronic gear, Speed units setting, Smoothing filter, S-curve acceleration/deceleration, Stop function, Command change, Stroke limit, Interlock, Rough match output, Torque limit, Backlash compensation, Interference check, Position switch, Home position search limit, Absolute position detection system, Other axes start, Tandem operation, Pass position interrupt, Log function, etc.

## Related Catalogs



Mitsubishi Electric Servo System Controllers  
MELSEC iQ-R series/  
MELSEC iQ-F series catalog  
L(NA)03100



Mitsubishi Electric Servo System Controllers catalog  
L(NA)03062



MELSEC iQ-R Series  
iQ Platform-compatible PAC  
catalog  
L(NA)08298ENG



MELSEC iQ-F Series  
iQ Platform-compatible  
PLC catalog  
L(NA)08428ENG



Programmable Controllers  
MELSEC-L series catalog  
L(NA)08159E



C Controller/Personal Computer  
Embedded Type Servo System  
Controller catalog  
L(NA)03097

## Our total solution for your satisfaction

### MELSERVO Solution

Introducing the MELSERVO solutions for problems in production sites.  
We offer the optimal solutions for various problems in various production sites.

#### Vertical Form, Fill & Seal For food/beverage bag filling and packing

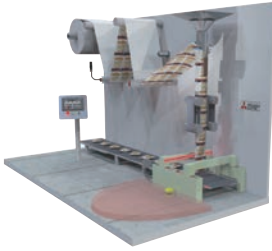

- Solution 01 **Stabilizing the packing quality**  
↳ **Synchronous Control**
- Solution 02 **Shorter cycle time without increasing shock to a machine**  
↳ **Cam Control**
- Solution 03 **Creating a safety system**  
↳ **Safety Sub-Function**

#### Rotary Knife For steel & paper cutting, stamping and labeling

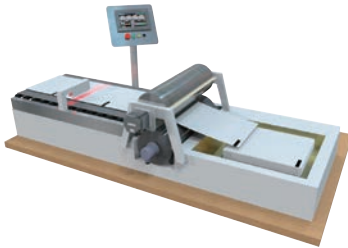

- Solution 01 **Cam creation on HMI screen**  
↳ **Cam Auto-Generation Function**
- Solution 02 **Cutting the sheet using the registration mark as a reference**  
↳ **Mark Detection Function**

#### Motion Alignment (X-Y-θ) For equipment requiring more accurate positioning

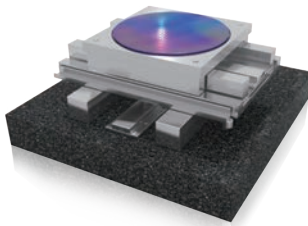

- Solution 01 **More accurate positioning**  
↳ **COGNEX Vision System**
- Solution 02 **More precise drive operation**  
↳ **Direct Drive Motor**
- Solution 03 **Shorter cycle time**  
↳ **Target Position Change Function**

#### Gantry Application For material handling, automatic assembly and scanning

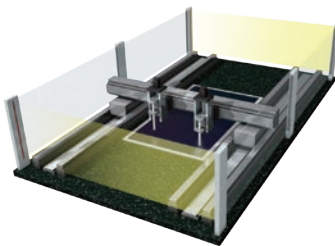

- Solution 01 **Suppression of the machine vibration**  
↳ **Vibration Suppression Functions**
- Solution 02 **Simpler multi-head configuration**  
↳ **Linear Servo Motor**
- Solution 03 **Synchronized movement of axis-1 and axis-2**  
↳ **Tandem Configuration**

#### Pick and Place Robot For material loading/unloading and sealing



- Solution 01 **Suppression of the machine vibration**  
↳ **Advanced Vibration Suppression Control II**
- Solution 02 **Simpler setting of the suppression function**  
↳ **Machine Analyzer and Machine Resonance Suppression Filter**
- Solution 03 **Smaller size machine**  
↳ **3-axis Type Servo Amplifier**

MELSERVO-J4 and our servo products come with a wide selection of functions to solve the challenges in production. Our newest functions are easier to use, and safer than ever before.

## Driver Communication Function Torque-coordination of multiple axes

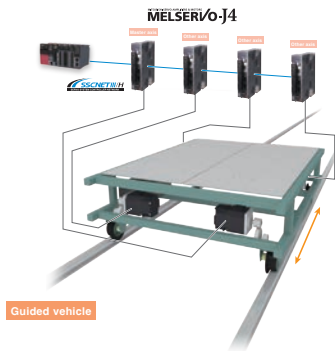

- 1 Easy configuration of torque-assist system
- 2 Space utilization with distributed arrangement of the other axes

While the master axis is operated in position or speed control mode, the other axes are operated in torque control mode with the same torque as the master axis.

Since multiple smaller-capacity servo motors are used for sharing load instead of a large-capacity servo motor, minimal space can be effectively used. The torque command is transmitted from the master axis to the other axes via SSCNET III/H with a parameter setting, and no additional wiring is required for this function. Each SSCNET III/H line can have up to eight master axes.

## Super Trace Control Increasing path accuracy



- 1 Actual path exactly as commanded
- 2 Reduction of deviation errors on arc motion

In normal control, a position deviation occurs in response to the position command from the controller, causing a deviation error between the machine axis' target path and the actual path. The super trace control function reduces this deviation error close to zero, enabling actual movement almost exactly as commanded, resulting in improved processing.

## Pressure Control High-response pressure control

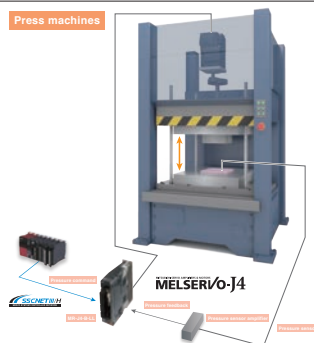

- 1 High-response pressure control
- 2 Smooth switching between pressure and position control
- 3 Easy adjustment

- Pressure sensor signals are inputted directly to the servo amplifier, enabling high-response feedback control.
- Pressure commands (applying/holding/releasing pressure) can be created easily on the profile setting window of the engineering software.



Refer to "MELSERVO-J4 Function Guide (L(NA)03152ENG)" for details.

## e-F@ctory Solution

e-F@ctory is Mitsubishi Electric's integrated concept to build reliable and flexible manufacturing systems that enable users to achieve many of their high speed, information driven manufacturing aspirations. Through its partner solution activity, the e-F@ctory Alliance, and its work with open network associations such as The CC-Link Partners Association (CLPA), users can build comprehensive solutions based on a wide ranging "best in class" principle.

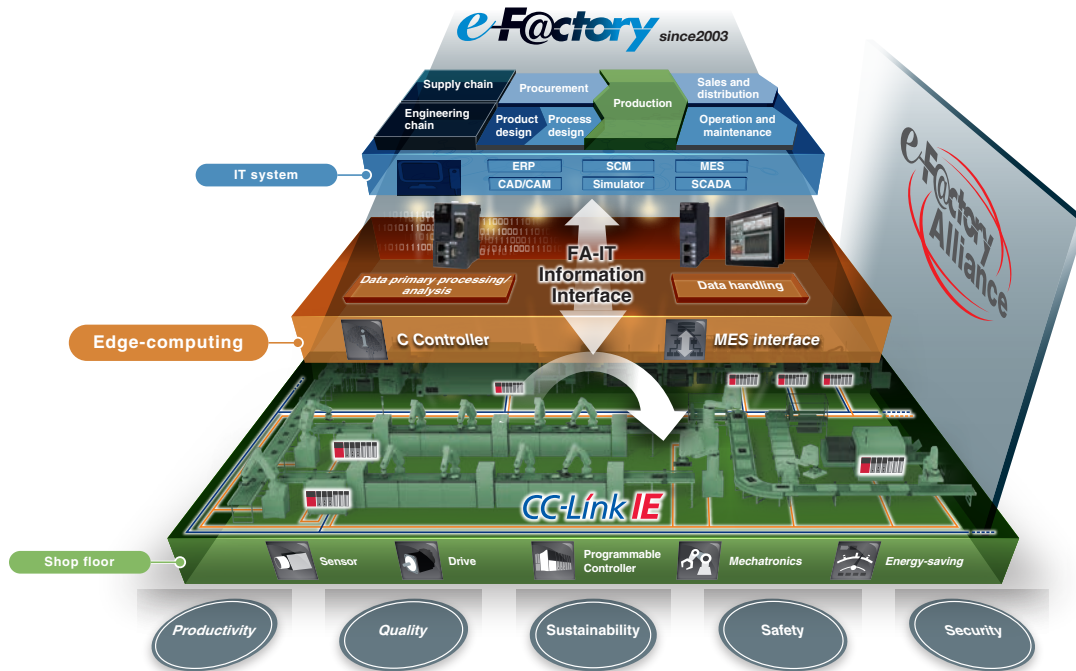

## iQ Platform Solution

iQ platform minimizes TCO\* by providing innovative solutions for:

- Building a stable production system with enhanced productivity
- Reducing the time from system development to startup for shorter product cycles
- Efficiently managing and servicing the system to reduce down time and maintain productivity
- Ensuring product quality by swiftly processing large volumes of control data and production data and establishing traceability

\* TCO: Total Cost of Ownership



## e-F@ctory Alliance

The e-F@ctory Alliance is a FA manufacturer partnering program that strongly links the connection compatibility of Mitsubishi Electric FA equipment utilizing excellent software and machinery offered by partners, thereby enabling systems to be built by systems integration partners and the proposal of optimal solutions to customers.

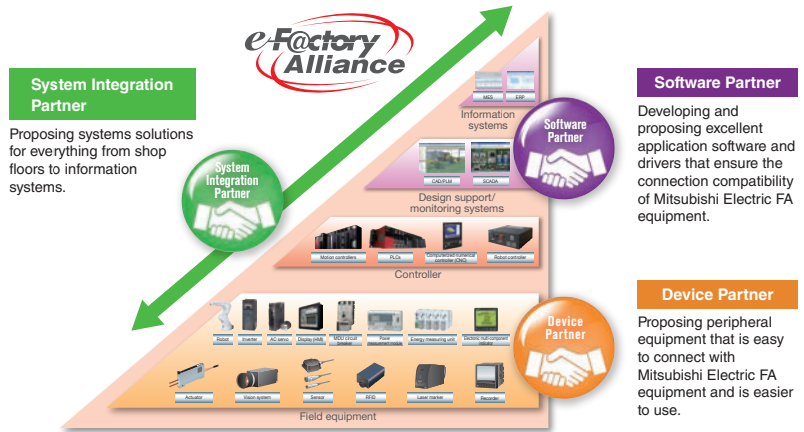

## Mitsubishi Electric Servo System Partners

Servo system includes controllers, servo drivers, actuators, sensors, etc. The servo system takes a step further to accelerate the equipment revolution by collaborating with our partner companies. Now that a wide variety of partner products are available such as pressure-resistance, explosion-proof type motors, custom-made servo motors, magnetic type linear encoders, your system will be configured flexibly.

The Mitsubishi Electric Servo System Partner Association is a subcommittee of e-F@ctory Alliance.





**MEMO**





# 1

## Servo Amplifiers

Model Designation.....	1-1
Combinations of 1-Axis Servo Amplifier and Servo Motor.....	1-4
Combinations of 1-Axis Servo Amplifier and Servo Motor with Functional Safety.....	1-7
Combinations of Multi-Axis Servo Amplifier and Servo Motors.....	1-8
Selection of Power Regeneration Converter Unit, MR-J4-DU_B_(-RJ) Drive Unit, and Servo Amplifier.....	1-9
MR-J4-GF/MR-J4-GF-RJ Connections with Peripheral Equipment.....	1-10
MR-J4-GF/MR-J4-GF-RJ Specifications.....	1-11
MR-J4-GF/MR-J4-GF-RJ Standard Wiring Diagram Example.....	1-15
STO I/O Signal Connector (CN8) Connection Example.....	1-16
Main/Control Circuit Power Supply Connection Example.....	1-17
Servo Motor Connection Example (for MR-J4-GF/MR-J4-B/MR-J4-A).....	1-22
External Encoder Connection Specifications.....	1-31
Servo Motor Connection Example (for MR-J4-GF-RJ/MR-J4-B-RJ/MR-J4-A-RJ).....	1-32
MR-J4-GF/MR-J4-GF-RJ Dimensions.....	1-38
MR-J4-B/MR-J4-B-RJ Connections with Peripheral Equipment.....	1-43
MR-J4-B/MR-J4-B-RJ/MR-J4-DU_B/MR-J4-DU_B-RJ/MR-J4-DU_B4-RJ100 Specifications.....	1-44
MR-CV Specifications.....	1-51
MR-CR Specifications.....	1-53
MR-J4-B/MR-J4-B-RJ Standard Wiring Diagram Example.....	1-54
MR-J4-DU_B4-RJ100 System Configurations/Standard Wiring Diagram Example.....	1-55
MR-J4-B/MR-J4-B-RJ/MR-J4-DU_B/MR-J4-DU_B-RJ/MR-J4-DU_B4-RJ100 Dimensions.....	1-61
MR-CV Dimensions.....	1-68
Panel Cut Dimensions for Power Regeneration Converter Unit and Drive unit.....	1-70
MR-CR Dimensions.....	1-71
Panel Cut Dimensions for Resistance Regeneration Converter Unit and Drive Unit.....	1-71
MR-J4W2-B/MR-J4W3-B Connections with Peripheral Equipment.....	1-72
MR-J4W2-B/MR-J4W3-B/MR-J4W2-0303B6 Specifications.....	1-73
MR-J4W2-B/MR-J4W3-B Standard Wiring Diagram Example.....	1-78
Servo Motor Connection Example (for MR-J4W2-B/MR-J4W3-B).....	1-80
MR-J4W2-0303B6 Standard Wiring Diagram Example.....	1-86
Main/Control Circuit Power Supply Connection Example (for MR-J4W2-0303B6).....	1-87
Servo Motor Connection Example (for MR-J4W2-0303B6).....	1-87
MR-J4W2-B/MR-J4W3-B/MR-J4W2-0303B6 Dimensions.....	1-88
MR-J4-A/MR-J4-A-RJ Connections with Peripheral Equipment.....	1-90
MR-J4-A/MR-J4-A-RJ/MR-J4-DU_A/MR-J4-DU_A-RJ/MR-J4-03A6/MR-J4-03A6-RJ Specifications.....	1-91
MR-J4-A/MR-J4-A-RJ/MR-J4-03A6/MR-J4-03A6-RJ Standard Wiring Diagram Example.....	1-100
MR-J4-03A6/MR-J4-03A6-RJ RS-422 Serial Communication Connection Example.....	1-106
Main/Control Circuit Power Supply Connection Example (for MR-J4-03A6/MR-J4-03A6-RJ).....	1-107
Servo Motor Connection Example (for MR-J4-03A6/MR-J4-03A6-RJ).....	1-107
MR-J4-A/MR-J4-A-RJ/MR-J4-DU_A/MR-J4-DU_A-RJ/MR-J4-03A6/MR-J4-03A6-RJ Dimensions.....	1-108
Positioning Function.....	1-115
MODBUS® RTU Specifications.....	1-129
Simple Cam Specifications.....	1-130

**GF** MR-J4-GF **GF-RJ** MR-J4-GF-RJ **B** MR-J4-B/MR-J4-DU\_B **B-RJ** MR-J4-B-RJ/MR-J4-DU\_B-RJ **B-RJ100** MR-J4-DU\_B4-RJ100  
**WB** MR-J4W2-B/MR-J4W3-B **A** MR-J4-A/MR-J4-DU\_A **A-RJ** MR-J4-A-RJ/MR-J4-DU\_A-RJ

\* Refer to p. 5-99 in this catalog for conversion of units.

\* In this section, a term of servo amplifier includes a combination of the drive unit and the power regeneration converter unit or the resistance regeneration converter unit.

# Servo Amplifiers

## Model Designation for 1-Axis Servo Amplifier (Note 14)

**GF GF-RJ B B-RJ A A-RJ**

### MR-J4-10GF -

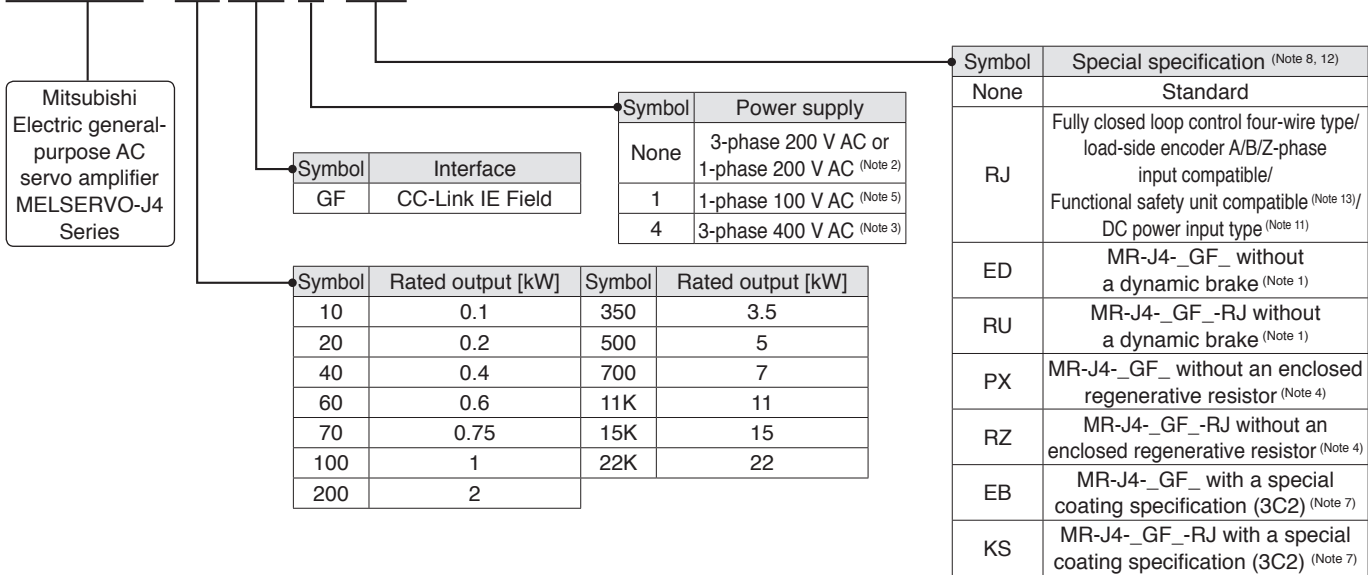

### MR-J4-10B -

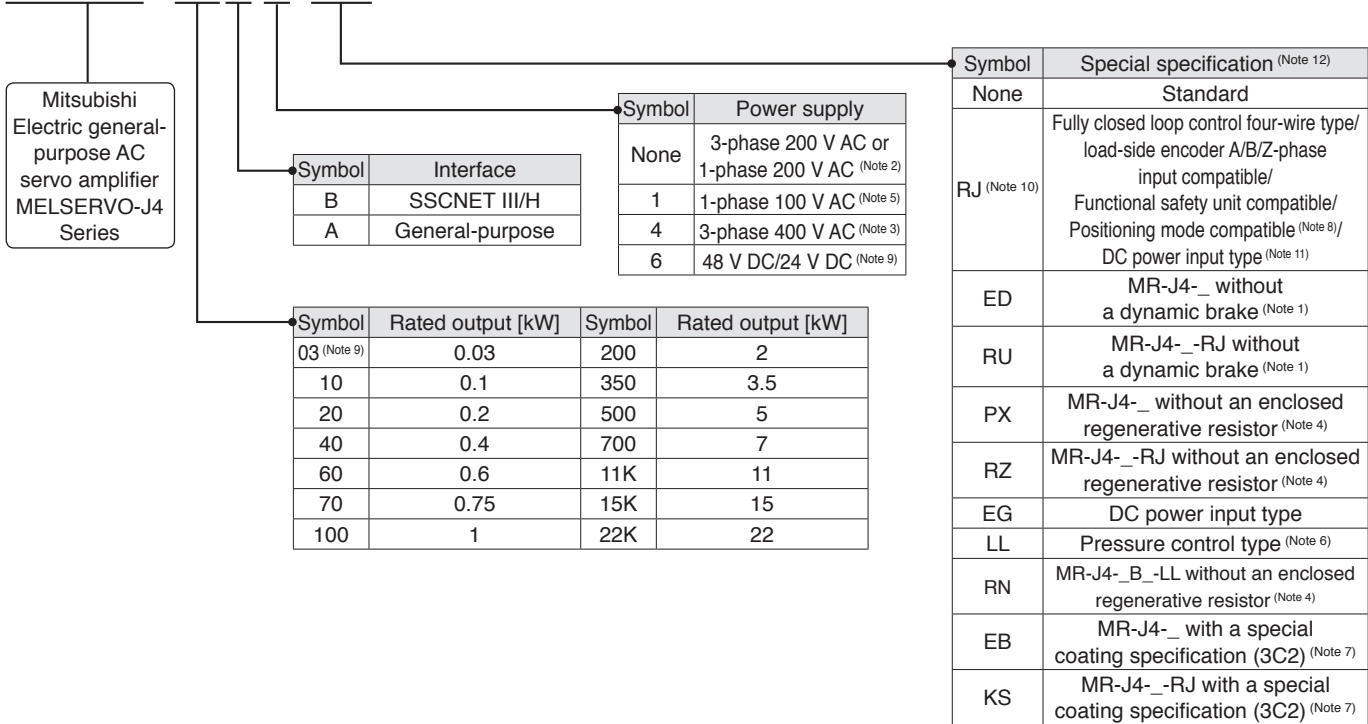

- Notes: 1. Dynamic brake which is built in 7 kW or smaller servo amplifiers is removed. When the servo amplifiers without the dynamic brake are used, the servo motors coast to a stop and do not stop immediately at alarm occurrence or power failure. Take measures to ensure safety on the entire system. When specified servo motors are used, the electronic dynamic brake may activate at an alarm occurrence. The dynamic brake can be disabled with a servo parameter setting. Refer to relevant Servo Amplifier Instruction Manual for details.
2. A power supply of 1-phase 200 V AC is supported by 0.1 kW to 2 kW servo amplifiers.
3. A power supply of 3-phase 400 V AC is supported by 0.6 kW and 1 kW or larger servo amplifiers.
4. Available in 11 kW to 22 kW servo amplifiers. A regenerative resistor (standard accessory) is not enclosed. Refer to relevant Servo Amplifier Instruction Manual for details.
5. A power supply of 1-phase 100 V AC is supported by 0.1 kW to 0.4 kW servo amplifiers.
6. MR-J4-\_B\_-LL is available. Refer to "MR-J4-\_B\_-LL MR-J4-DU\_B\_-LL Servo Amplifier Instruction Manual" for the pressure control compatible servo amplifiers.
7. The special coating (IEC 60721-3-3:1994 Class 3C2) is applied to the circuit board of the servo amplifier. Refer to relevant Servo Amplifier Instruction Manual for details.
8. Positioning mode is supported by MR-J4-GF(-RJ)/MR-J4-A-RJ servo amplifiers.
9. Supported by MR-J4-03A6(-RJ) servo amplifier.
10. Only positioning mode is supported by MR-J4-03A6-RJ. The fully closed loop control, load-side encoder A/B/Z-phase input, and the functional safety unit are not supported.
11. Only 200 V is available.
12. For the servo amplifier software version which supports each function, refer to the specification page of each unit.
13. When the servo amplifier is connected to CC-Link IE Field Network Basic, an MR-D30 functional safety unit is not supported.
14. This section describes what each symbol in a model name indicates. Some combinations of symbols are not available.

Model Designation for Multi-Axis Servo Amplifier (Note 14)

MR-J4W2-22B-

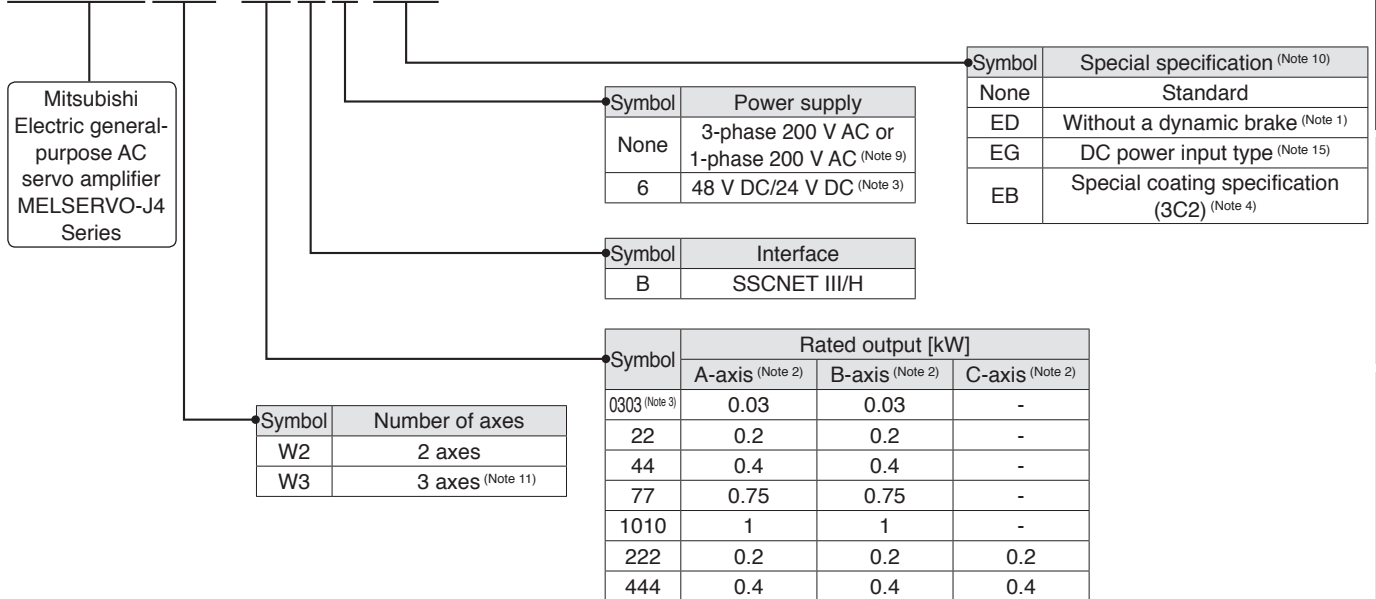

Model Designation for Drive Unit

B B-RJ B-RJ100 A A-RJ

MR-J4-DU900B-

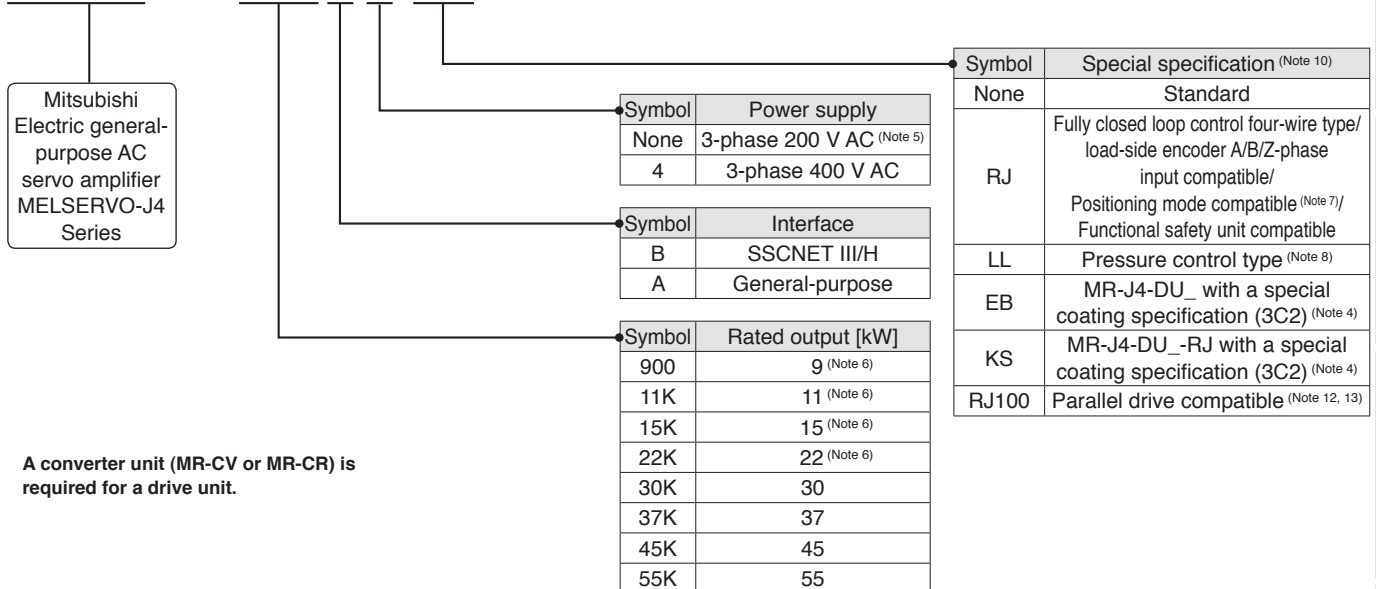

A converter unit (MR-CV or MR-CR) is required for a drive unit.

- Notes: 1. Dynamic brake which is built in servo amplifiers is removed. When the servo amplifiers without the dynamic brake are used, the servo motors coast to a stop and do not stop immediately at alarm occurrence or power failure. Take measures to ensure safety on the entire system. When specified servo motors are used, the electronic dynamic brake may activate at an alarm occurrence. The dynamic brake can be disabled with a servo parameter setting. Refer to relevant Servo Amplifier Instruction Manual for details.
2. A-axis, B-axis, and C-axis indicate names of axes of the multi-axis servo amplifier. The C-axis is available for the 3-axis servo amplifier.
3. Supported by MR-J4W2-0303B6 servo amplifier.
4. The special coating (IEC 60721-3-3:1994 Class 3C2) is applied to the circuit board of the servo amplifier and the drive unit of 30 kW or larger. Refer to relevant Servo Amplifier Instruction Manual for details.
5. A power supply of 3-phase 200 V AC is supported by 37 kW or smaller drive units.
6. Available only with MR-J4-DU\_B\_(-RJ).
7. Positioning mode is supported by MR-J4-DU\_A\_-RJ drive unit.
8. MR-J4-DU\_B\_-LL is available in 30 kW or larger drive units. Refer to "MR-J4\_-B\_-LL MR-J4-DU\_B\_-LL Servo Amplifier Instruction Manual" for the pressure control compatible servo amplifiers.
9. A power supply of 1-phase 200 V AC is supported by 0.2 kW to 0.75 kW servo amplifiers.
10. For the servo amplifier/drive unit software version which supports each function, refer to the specification page of each unit.
11. Available only with 0.2 kW and 0.4 kW.
12. Available only with the drive unit of 3-phase 400 V AC and 45 kW or higher.
13. Refer to "Compatible Controllers" on p. 1-50 in this catalog for compatible controllers.
14. This section describes what each symbol in a model name indicates. Some combinations of symbols are not available.
15. Contact your local sales office for more details.

# Servo Amplifiers

## Model Designation for Power Regeneration Converter Unit (Note 1, 6)

**B** **B-RJ** **B-RJ100**

MR-CV11K

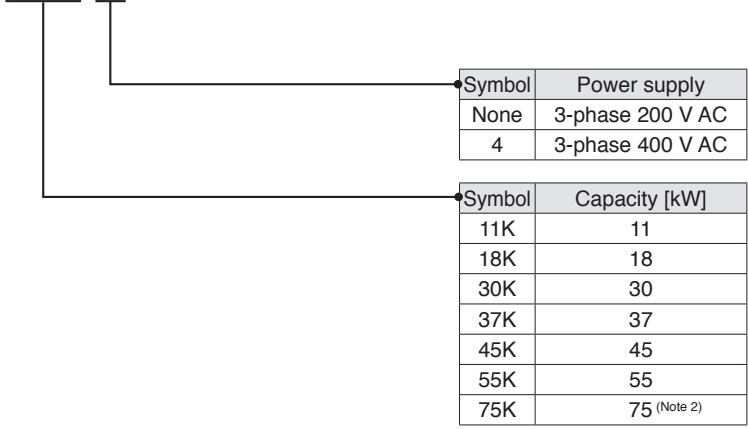

## Model Designation for Resistance Regeneration Converter Unit (Note 3, 5)

**B** **B-RJ** **A** **A-RJ**

MR-CR55K -

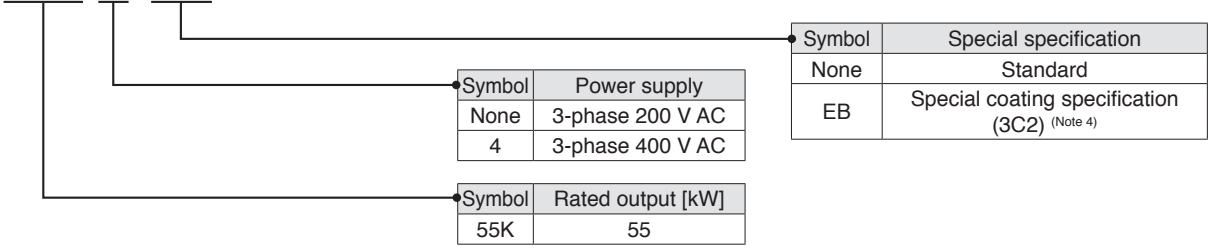

- Notes: 1. The power regeneration converter unit is supported by MR-J4-DU\_B(4)(-RJ) and MR-J4-DU\_B4-RJ100 drive units. It is not supported by MR-J4-DU\_A(4)(-RJ) drive unit. Refer to "MR-CV\_ MR-CR55K\_ MR-J4-DU\_B\_(-RJ) MR-J4-DU\_A\_(-RJ) Instruction Manual" for the combination with MR-J4-\_B(4)(-RJ) servo amplifiers.
2. Available only with the power regeneration converter unit of 400 V.
3. One unit of resistance regeneration converter unit is required for each drive unit.
4. The special coating (IEC 60721-3-3:1994 Class 3C2) is applied to the circuit board of the resistance regeneration converter unit. Refer to "MR-CV\_ MR-CR55K\_ MR-J4-DU\_B\_(-RJ) MR-J4-DU\_A\_(-RJ) Instruction Manual" for details.
5. Use the resistance regeneration converter unit with MR-J4-DU\_B(4)(-RJ) or MR-J4-DU\_A(4)(-RJ) unit. The resistance regeneration converter unit is not compatible with MR-J4-DU\_B4-RJ100 and 22 kW or smaller MR-J4-DU\_B(4)(-RJ).
6. This section describes what each symbol in a model name indicates. Some combinations of symbols are not available.

Combinations of 1-Axis Servo Amplifier and Servo Motor

GF GF-RJ B B-RJ A A-RJ

MR-J4-GF/MR-J4-GF-RJ/MR-J4-B/MR-J4-B-RJ/MR-J4-A/MR-J4-A-RJ (200 V)

Servo amplifier	Rotary servo motor	Linear servo motor (primary side) <sup>(Note 1)</sup>	Direct drive motor
MR-J4-10GF(-RJ) MR-J4-10B(-RJ) MR-J4-10A(-RJ)	HG-KR053(B), 13(B) HG-MR053(B), 13(B)	-	-
MR-J4-20GF(-RJ) MR-J4-20B(-RJ) MR-J4-20A(-RJ)	HG-KR23(B) HG-MR23(B)	LM-U2PAB-05M-0SS0 LM-U2PBB-07M-1SS0	TM-RG2M002C30 <sup>(Note 5)</sup> TM-RU2M002C30 <sup>(Note 5)</sup> TM-RG2M004E30 <sup>(Note 5)</sup> TM-RU2M004E30 <sup>(Note 5)</sup> TM-RFM002C20
MR-J4-40GF(-RJ) MR-J4-40B(-RJ) MR-J4-40A(-RJ)	HG-KR43(B) HG-MR43(B)	LM-H3P2A-07P-BSS0 LM-H3P3A-12P-CSS0 LM-K2P1A-01M-2SS1 LM-U2PAD-10M-0SS0 LM-U2PAF-15M-0SS0	TM-RG2M004E30 <sup>(Note 4, 5)</sup> TM-RU2M004E30 <sup>(Note 4, 5)</sup> TM-RG2M009G30 <sup>(Note 5)</sup> TM-RU2M009G30 <sup>(Note 5)</sup> TM-RFM004C20
MR-J4-60GF(-RJ) MR-J4-60B(-RJ) MR-J4-60A(-RJ)	HG-SR51(B), 52(B) HG-JR53(B)	LM-U2PBD-15M-1SS0	TM-RFM006C20 TM-RFM006E20
MR-J4-70GF(-RJ) MR-J4-70B(-RJ) MR-J4-70A(-RJ)	HG-KR73(B) HG-MR73(B) HG-JR73(B) HG-UR72(B)	LM-H3P3B-24P-CSS0 LM-H3P3C-36P-CSS0 LM-H3P7A-24P-ASS0 LM-K2P2A-02M-1SS1 LM-U2PBF-22M-1SS0	TM-RFM012E20 TM-RFM012G20 TM-RFM040J10
MR-J4-100GF(-RJ) MR-J4-100B(-RJ) MR-J4-100A(-RJ)	HG-SR81(B), 102(B) HG-JR53(B) <sup>(Note 2, 3)</sup> , 103(B)	-	TM-RFM018E20
MR-J4-200GF(-RJ) MR-J4-200B(-RJ) MR-J4-200A(-RJ)	HG-SR121(B), 201(B), 152(B), 202(B) HG-JR73(B) <sup>(Note 2, 3)</sup> , 103(B) <sup>(Note 2, 3)</sup> , 153(B), 203(B) HG-RR103(B), 153(B) HG-UR152(B)	LM-H3P3D-48P-CSS0 LM-H3P7B-48P-ASS0 LM-H3P7C-72P-ASS0 LM-FP2B-06M-1SS0 LM-K2P1C-03M-2SS1 LM-U2P2B-40M-2SS0	-
MR-J4-350GF(-RJ) MR-J4-350B(-RJ) MR-J4-350A(-RJ)	HG-SR301(B), 352(B) HG-JR153(B) <sup>(Note 2)</sup> , 203(B) <sup>(Note 2)</sup> , 353(B) HG-RR203(B) HG-UR202(B)	LM-H3P7D-96P-ASS0 LM-K2P2C-07M-1SS1 LM-K2P3C-14M-1SS1 LM-U2P2C-60M-2SS0	TM-RFM048G20 TM-RFM072G20 TM-RFM120J10
MR-J4-500GF(-RJ) MR-J4-500B(-RJ) MR-J4-500A(-RJ)	HG-SR421(B), 502(B) HG-JR353(B) <sup>(Note 2)</sup> , 503(B) HG-RR353(B), 503(B) HG-UR352(B), 502(B)	LM-FP2D-12M-1SS0 LM-FP4B-12M-1SS0 LM-K2P2E-12M-1SS1 LM-K2P3E-24M-1SS1 LM-U2P2D-80M-2SS0	TM-RFM240J10
MR-J4-700GF(-RJ) MR-J4-700B(-RJ) MR-J4-700A(-RJ)	HG-SR702(B) HG-JR503(B) <sup>(Note 2)</sup> , 703(B), 601(B), 701M(B)	LM-FP2F-18M-1SS0 LM-FP4D-24M-1SS0	-
MR-J4-11KGF(-RJ) MR-J4-11KB(-RJ) MR-J4-11KA(-RJ)	HG-JR903(B), 801(B), 12K1(B), 11K1M(B)	LM-FP4F-36M-1SS0	-
MR-J4-15KGF(-RJ) MR-J4-15KB(-RJ) MR-J4-15KA(-RJ)	HG-JR15K1, 15K1M(B)	LM-FP4H-48M-1SS0	-
MR-J4-22KGF(-RJ) MR-J4-22KB(-RJ) MR-J4-22KA(-RJ)	HG-JR20K1, 25K1, 22K1M	-	-

- Notes: 1. Models of the linear servo motor primary side are listed in this page. For compatible models of the secondary side, refer to "Combinations of Linear Servo Motor and Servo Amplifier" under section 3 Linear Servo Motor in this catalog.  
 2. This combination increases the maximum torque from 300% to 400% of the rated torque.  
 3. When a 1-phase 200 V AC input is used, increasing the maximum torque to 400% is not possible with HG-JR servo motor series.  
 4. This combination increases the rated and maximum torque.  
 5. TM-RG2M/TM-RU2M series is supported by the servo amplifiers with software version C8 or later.

Servo Amplifiers

Rotary Servo Motors

Linear Servo Motors

Direct Drive Motors

Options/Peripheral Equipment

LVs/Wires

Product List

Precautions

# Servo Amplifiers

## Combinations of 1-Axis Servo Amplifier and Servo Motor

GF GF-RJ B B-RJ A A-RJ

### MR-J4-DU\_B/MR-J4-DU\_B-RJ/MR-J4-DU\_A/MR-J4-DU\_A-RJ (200 V)

Drive unit	Rotary servo motor	Linear servo motor (primary side) <sup>(Note 1)</sup>	Direct drive motor
MR-J4-DU900B(-RJ)	HG-SR702(B) <sup>(Note 3)</sup> HG-JR503(B) <sup>(Note 2)</sup> , 703(B) <sup>(Note 3)</sup> , 903(B), 601(B), 801(B), 701M(B) <sup>(Note 3)</sup>	LM-FP2F-18M-1SS0 LM-FP4D-24M-1SS0	-
MR-J4-DU11KB(-RJ)	HG-JR12K1(B), 11K1M(B)	LM-FP4F-36M-1SS0	-
MR-J4-DU15KB(-RJ)	HG-JR15K1, 15K1M(B)	LM-FP4H-48M-1SS0	-
MR-J4-DU22KB(-RJ)	HG-JR20K1, 25K1, 22K1M	-	-
MR-J4-DU30KB(-RJ)	HG-JR30K1	-	-
MR-J4-DU30KA(-RJ)	HG-JR30K1M	-	-
MR-J4-DU37KB(-RJ)	HG-JR37K1	-	-
MR-J4-DU37KA(-RJ)	HG-JR37K1M	-	-

### MR-J4-GF1/MR-J4-GF1-RJ/MR-J4-B1/MR-J4-B1-RJ/MR-J4-A1/MR-J4-A1-RJ (100 V)

Servo amplifier	Rotary servo motor	Linear servo motor (primary side) <sup>(Note 1)</sup>	Direct drive motor
MR-J4-10GF1(-RJ) MR-J4-10B1(-RJ) MR-J4-10A1(-RJ)	HG-KR053(B), 13(B) HG-MR053(B), 13(B)	-	-
MR-J4-20GF1(-RJ) MR-J4-20B1(-RJ) MR-J4-20A1(-RJ)	HG-KR23(B) HG-MR23(B)	LM-U2PAB-05M-0SS0 LM-U2PBB-07M-1SS0	TM-RG2M002C30 <sup>(Note 5)</sup> TM-RU2M002C30 <sup>(Note 5)</sup> TM-RG2M004E30 <sup>(Note 5)</sup> TM-RU2M004E30 <sup>(Note 5)</sup> TM-RFM002C20
MR-J4-40GF1(-RJ) MR-J4-40B1(-RJ) MR-J4-40A1(-RJ)	HG-KR43(B) HG-MR43(B)	LM-H3P2A-07P-BSS0 LM-H3P3A-12P-CSS0 LM-K2P1A-01M-2SS1 LM-U2PAD-10M-0SS0 LM-U2PAF-15M-0SS0	TM-RG2M004E30 <sup>(Note 4, 5)</sup> TM-RU2M004E30 <sup>(Note 4, 5)</sup> TM-RG2M009G30 <sup>(Note 5)</sup> TM-RU2M009G30 <sup>(Note 5)</sup> TM-RFM004C20

### MR-J4-GF4/MR-J4-GF4-RJ/MR-J4-B4/MR-J4-B4-RJ/MR-J4-A4/MR-J4-A4-RJ (400 V)

Servo amplifier	Rotary servo motor	Linear servo motor (primary side) <sup>(Note 1)</sup>	Direct drive motor
MR-J4-60GF4(-RJ) MR-J4-60B4(-RJ) MR-J4-60A4(-RJ)	HG-SR524(B) HG-JR534(B)	-	-
MR-J4-100GF4(-RJ) MR-J4-100B4(-RJ) MR-J4-100A4(-RJ)	HG-SR1024(B) HG-JR534(B) <sup>(Note 2)</sup> , 734(B), 1034(B)	-	-
MR-J4-200GF4(-RJ) MR-J4-200B4(-RJ) MR-J4-200A4(-RJ)	HG-SR1524(B), 2024(B) HG-JR734(B) <sup>(Note 2)</sup> , 1034(B) <sup>(Note 2)</sup> , 1534(B), 2034(B)	-	-
MR-J4-350GF4(-RJ) MR-J4-350B4(-RJ) MR-J4-350A4(-RJ)	HG-SR3524(B) HG-JR1534(B) <sup>(Note 2)</sup> , 2034(B) <sup>(Note 2)</sup> , 3534(B)	-	-
MR-J4-500GF4(-RJ) MR-J4-500B4(-RJ) MR-J4-500A4(-RJ)	HG-SR5024(B) HG-JR3534(B) <sup>(Note 2)</sup> , 5034(B)	-	-
MR-J4-700GF4(-RJ) MR-J4-700B4(-RJ) MR-J4-700A4(-RJ)	HG-SR7024(B) HG-JR5034(B) <sup>(Note 2)</sup> , 7034(B), 6014(B), 701M4(B)	-	-
MR-J4-11KGF4(-RJ) MR-J4-11KB4(-RJ) MR-J4-11KA4(-RJ)	HG-JR9034(B), 8014(B), 12K14(B), 11K1M4(B)	-	-
MR-J4-15KGF4(-RJ) MR-J4-15KB4(-RJ) MR-J4-15KA4(-RJ)	HG-JR15K14, 15K1M4(B)	-	-
MR-J4-22KGF4(-RJ) MR-J4-22KB4(-RJ) MR-J4-22KA4(-RJ)	HG-JR20K14, 25K14, 22K1M4	LM-FP5H-60M-1SS0	-

Notes: 1. Models of the linear servo motor primary side are listed in this page. For compatible models of the secondary side, refer to "Combinations of Linear Servo Motor and Servo Amplifier" under section 3 Linear Servo Motor in this catalog.

2. This combination increases the maximum torque from 300% to 400% of the rated torque.

3. The maximum torque will be increased when the "Selection of maximally increasing torque function with drive unit" is enabled with a parameter.

4. This combination increases the rated and maximum torque.

5. TM-RG2M/TM-RU2M series is supported by the servo amplifiers with software version C8 or later.

Combinations of 1-Axis Servo Amplifier and Servo Motor

**B** **B-RJ** **A** **A-RJ**

MR-J4-DU\_B4/MR-J4-DU\_B4-RJ/MR-J4-DU\_A4/MR-J4-DU\_A4-RJ (400 V)

Drive unit	Rotary servo motor	Linear servo motor (primary side) <sup>(Note 1)</sup>	Direct drive motor
MR-J4-DU900B4(-RJ)	HG-SR7024(B) <sup>(Note 3)</sup> HG-JR5034(B) <sup>(Note 2)</sup> , 7034(B) <sup>(Note 3)</sup> , 9034(B), 6014(B), 8014(B), 701M4(B) <sup>(Note 3)</sup>	-	-
MR-J4-DU11KB4(-RJ)	HG-JR12K14(B), 11K1M4(B)	-	-
MR-J4-DU15KB4(-RJ)	HG-JR15K14, 15K1M4(B)	-	-
MR-J4-DU22KB4(-RJ)	HG-JR20K14, 25K14, 22K1M4	LM-FP5H-60M-1SS0	-
MR-J4-DU30KB4(-RJ)	HG-JR30K14	-	-
MR-J4-DU30KA4(-RJ)	HG-JR30K1M4	-	-
MR-J4-DU37KB4(-RJ)	HG-JR37K14	-	-
MR-J4-DU37KA4(-RJ)	HG-JR37K1M4	-	-
MR-J4-DU45KB4(-RJ)	HG-JR45K1M4	-	-
MR-J4-DU45KA4(-RJ)	HG-JR45K1M4	-	-
MR-J4-DU55KB4(-RJ)	HG-JR55K1M4	-	-
MR-J4-DU55KA4(-RJ)	HG-JR55K1M4	-	-

MR-J4-03A6 (48 V DC/24 V DC)

Servo amplifier	Rotary servo motor	Linear servo motor (primary side) <sup>(Note 1)</sup>	Direct drive motor
MR-J4-03A6(-RJ)	HG-AK0136(B), 0236(B), 0336(B)	-	-

Notes: 1. Models of the linear servo motor primary side are listed in this page. For compatible models of the secondary side, refer to "Combinations of Linear Servo Motor and Servo Amplifier" under section 3 Linear Servo Motor in this catalog.

2. This combination increases the maximum torque from 300% to 400% of the rated torque.

3. The maximum torque will be increased when the "Selection of maximally increasing torque function with drive unit" is enabled with a parameter.

Servo Amplifiers  
Rotary Servo Motors  
Linear Servo Motors  
Direct Drive Motors  
Options/Peripheral Equipment  
LVSWires  
Product List  
Precautions

# Servo Amplifiers

## Combinations of 1-Axis Servo Amplifier and Servo Motor with Functional Safety

**GF-RJ B-RJ B-RJ100 A-RJ**

The safety sub-function can be expanded when the servo motor with functional safety, MR-J4-GF-RJ/MR-J4-B-RJ/MR-J4-A-RJ servo amplifiers, and MR-D30 functional safety unit are combined.

### MR-J4-GF-RJ/MR-J4-B-RJ/MR-J4-A-RJ (200 V)

Servo amplifier	Servo motor with functional safety
MR-J4-10GF-RJ MR-J4-10B-RJ MR-J4-10A-RJ	HG-KR053(B)W0C, 13(B)W0C
MR-J4-20GF-RJ MR-J4-20B-RJ MR-J4-20A-RJ	HG-KR23(B)W0C
MR-J4-40GF-RJ MR-J4-40B-RJ MR-J4-40A-RJ	HG-KR43(B)W0C
MR-J4-60GF-RJ MR-J4-60B-RJ MR-J4-60A-RJ	HG-SR51(B)W0C, 52(B)W0C HG-JR53(B)W0C
MR-J4-70GF-RJ MR-J4-70B-RJ MR-J4-70A-RJ	HG-KR73(B)W0C HG-JR73(B)W0C
MR-J4-100GF-RJ MR-J4-100B-RJ MR-J4-100A-RJ	HG-SR81(B)W0C, 102(B)W0C HG-JR53(B)W0C <sup>(Note 1, 3)</sup> , 103(B)W0C
MR-J4-200GF-RJ MR-J4-200B-RJ MR-J4-200A-RJ	HG-SR121(B)W0C, 201(B)W0C, 152(B)W0C, 202(B)W0C HG-JR73(B)W0C <sup>(Note 1, 3)</sup> , 103(B)W0C <sup>(Note 1, 3)</sup> , 153(B)W0C, 203(B)W0C
MR-J4-350GF-RJ MR-J4-350B-RJ MR-J4-350A-RJ	HG-SR301(B)W0C, 352(B)W0C HG-JR153(B)W0C <sup>(Note 1)</sup> , 203(B)W0C <sup>(Note 1)</sup> , 353(B)W0C
MR-J4-500GF-RJ MR-J4-500B-RJ MR-J4-500A-RJ	HG-SR421(B)W0C, 502(B)W0C HG-JR353(B)W0C <sup>(Note 1)</sup> , 503(B)W0C
MR-J4-700GF-RJ MR-J4-700B-RJ MR-J4-700A-RJ	HG-SR702(B)W0C HG-JR503(B)W0C <sup>(Note 1)</sup> , 703(B)W0C, 701M(B)W0C
MR-J4-11KGF-RJ MR-J4-11KB-RJ MR-J4-11KA-RJ	HG-JR903(B)W0C, 11K1M(B)W0C
MR-J4-15KGF-RJ MR-J4-15KB-RJ MR-J4-15KA-RJ	HG-JR15K1M(B)W0C
MR-J4-22KGF-RJ MR-J4-22KB-RJ MR-J4-22KA-RJ	HG-JR22K1MW0C

### MR-J4-DU\_B-RJ (200 V)

Drive unit	Servo motor with functional safety
MR-J4-DU900B-RJ	HG-SR702(B)W0C <sup>(Note 2)</sup> HG-JR503(B)W0C <sup>(Note 1)</sup> , 703(B)W0C <sup>(Note 2)</sup> , 903(B)W0C, 701M(B)W0C <sup>(Note 2)</sup>
MR-J4-DU11KB-RJ	HG-JR11K1M(B)W0C
MR-J4-DU15KB-RJ	HG-JR15K1M(B)W0C
MR-J4-DU22KB-RJ	HG-JR22K1MW0C

### MR-J4-GF1-RJ/MR-J4-B1-RJ/MR-J4-A1-RJ (100 V)

Servo amplifier	Servo motor with functional safety
MR-J4-10GF1-RJ MR-J4-10B1-RJ MR-J4-10A1-RJ	HG-KR053(B)W0C, 13(B)W0C
MR-J4-20GF1-RJ MR-J4-20B1-RJ MR-J4-20A1-RJ	HG-KR23(B)W0C
MR-J4-40GF1-RJ MR-J4-40B1-RJ MR-J4-40A1-RJ	HG-KR43(B)W0C

### MR-J4-GF4-RJ/MR-J4-B4-RJ/MR-J4-A4-RJ (400 V)

Servo amplifier	Servo motor with functional safety
MR-J4-60GF4-RJ MR-J4-60B4-RJ MR-J4-60A4-RJ	HG-SR524(B)W0C HG-JR534(B)W0C
MR-J4-100GF4-RJ MR-J4-100B4-RJ MR-J4-100A4-RJ	HG-SR1024(B)W0C HG-JR534(B)W0C <sup>(Note 1)</sup> , 734(B)W0C, 1034(B)W0C
MR-J4-200GF4-RJ MR-J4-200B4-RJ MR-J4-200A4-RJ	HG-SR1524(B)W0C, 2024(B)W0C HG-JR734(B)W0C <sup>(Note 1)</sup> , 1034(B)W0C <sup>(Note 1)</sup> , 1534(B)W0C, 2034(B)W0C
MR-J4-350GF4-RJ MR-J4-350B4-RJ MR-J4-350A4-RJ	HG-SR3524(B)W0C HG-JR1534(B)W0C <sup>(Note 1)</sup> , 2034(B)W0C <sup>(Note 1)</sup> , 3534(B)W0C
MR-J4-500GF4-RJ MR-J4-500B4-RJ MR-J4-500A4-RJ	HG-SR5024(B)W0C HG-JR3534(B)W0C <sup>(Note 1)</sup> , 5034(B)W0C
MR-J4-700GF4-RJ MR-J4-700B4-RJ MR-J4-700A4-RJ	HG-SR7024(B)W0C HG-JR5034(B)W0C <sup>(Note 1)</sup> , 7034(B)W0C, 701M4(B)W0C
MR-J4-11KGF4-RJ MR-J4-11KB4-RJ MR-J4-11KA4-RJ	HG-JR9034(B)W0C, 11K1M4(B)W0C
MR-J4-15KGF4-RJ MR-J4-15KB4-RJ MR-J4-15KA4-RJ	HG-JR15K1M4(B)W0C
MR-J4-22KGF4-RJ MR-J4-22KB4-RJ MR-J4-22KA4-RJ	HG-JR22K1M4W0C

### MR-J4-DU\_B4-RJ (400 V)

Drive unit	Servo motor with functional safety
MR-J4-DU900B4-RJ	HG-SR7024(B)W0C <sup>(Note 2)</sup> HG-JR5034(B)W0C <sup>(Note 1)</sup> , 7034(B)W0C <sup>(Note 2)</sup> , 9034(B)W0C, 701M4(B)W0C <sup>(Note 2)</sup>
MR-J4-DU11KB4-RJ	HG-JR11K1M4(B)W0C
MR-J4-DU15KB4-RJ	HG-JR15K1M4(B)W0C
MR-J4-DU22KB4-RJ	HG-JR22K1M4W0C
MR-J4-DU55KB4-RJ100 x 2 <sup>(Note 4, 5)</sup>	HG-JR110K24W0C
MR-J4-DU45KB4-RJ100 x 4 <sup>(Note 4, 5)</sup>	HG-JR150K24W0C
MR-J4-DU45KB4-RJ100 x 4 <sup>(Note 4, 5)</sup>	HG-JR180K24W0C
MR-J4-DU55KB4-RJ100 x 4 <sup>(Note 4, 5)</sup>	HG-JR200K24W0C
MR-J4-DU55KB4-RJ100 x 4 <sup>(Note 4, 5)</sup>	HG-JR220K24W0C

Notes: 1. This combination increases the maximum torque from 300% to 400% of the rated torque.

2. The maximum torque will be increased when the "Selection of maximally increasing torque function with drive unit" is enabled with a parameter.

3. When a 1-phase 200 V AC input is used, increasing the maximum torque to 400% is not possible with HG-JR servo motor series.

4. The same number of power regeneration converter units as the drive units are required.

5. Refer to "Compatible Controllers" on p. 1-50 in this catalog for compatible controllers.



Combinations of Multi-Axis Servo Amplifier and Servo Motors

WB

MR-J4W2-B

Any combination of the rotary servo motors, the linear servo motors, and the direct drive motors with different series and capacities is possible as long as the servo motors are compatible with the servo amplifier.

Servo amplifier	Rotary servo motor	Linear servo motor (primary side) <sup>(Note 1)</sup>	Direct drive motor
MR-J4W2-22B	HG-KR053(B), 13(B), 23(B) HG-MR053(B), 13(B), 23(B)	LM-U2PAB-05M-0SS0 LM-U2PBB-07M-1SS0	TM-RG2M002C30 <sup>(Note 4)</sup> TM-RU2M002C30 <sup>(Note 4)</sup> TM-RG2M004E30 <sup>(Note 4)</sup> TM-RU2M004E30 <sup>(Note 4)</sup> TM-RFM002C20
MR-J4W2-44B	HG-KR053(B), 13(B), 23(B), 43(B) HG-MR053(B), 13(B), 23(B), 43(B)	LM-H3P2A-07P-BSS0 LM-H3P3A-12P-CSS0 LM-K2P1A-01M-2SS1 LM-U2PAB-05M-0SS0 LM-U2PAD-10M-0SS0 LM-U2PAF-15M-0SS0 LM-U2PBB-07M-1SS0	TM-RG2M002C30 <sup>(Note 4)</sup> TM-RU2M002C30 <sup>(Note 4)</sup> TM-RG2M004E30 <sup>(Note 3, 4)</sup> TM-RU2M004E30 <sup>(Note 3, 4)</sup> TM-RG2M009G30 <sup>(Note 4)</sup> TM-RU2M009G30 <sup>(Note 4)</sup> TM-RFM002C20 TM-RFM004C20
MR-J4W2-77B	HG-KR43(B), 73(B) HG-MR43(B), 73(B) HG-SR51(B), 52(B) HG-JR53(B), 73(B) HG-UR72(B)	LM-H3P2A-07P-BSS0 LM-H3P3A-12P-CSS0 LM-H3P3B-24P-CSS0 LM-H3P3C-36P-CSS0 LM-H3P7A-24P-ASS0 LM-K2P1A-01M-2SS1 LM-K2P2A-02M-1SS1 LM-U2PAD-10M-0SS0 LM-U2PAF-15M-0SS0 LM-U2PBD-15M-1SS0 LM-U2PBF-22M-1SS0	TM-RFM004C20 TM-RFM006C20 TM-RFM006E20 TM-RFM012E20 TM-RFM012G20 TM-RFM040J10
MR-J4W2-1010B	HG-KR43(B), 73(B) HG-MR43(B), 73(B) HG-SR51(B), 81(B), 52(B), 102(B) HG-JR53(B) <sup>(Note 2)</sup> , 73(B), 103(B) HG-UR72(B)	LM-H3P2A-07P-BSS0 LM-H3P3A-12P-CSS0 LM-H3P3B-24P-CSS0 LM-H3P3C-36P-CSS0 LM-H3P7A-24P-ASS0 LM-K2P1A-01M-2SS1 LM-K2P2A-02M-1SS1 LM-U2PAD-10M-0SS0 LM-U2PAF-15M-0SS0 LM-U2PBD-15M-1SS0 LM-U2PBF-22M-1SS0	TM-RFM004C20 TM-RFM006C20 TM-RFM006E20 TM-RFM012E20 TM-RFM012G20 TM-RFM018E20 TM-RFM040J10
MR-J4W2-0303B6	HG-AK0136(B), 0236(B), 0336(B)	-	-

MR-J4W3-B

Any combination of the rotary servo motors, the linear servo motors, and the direct drive motors with different series and capacities is possible as long as the servo motors are compatible with the servo amplifier.

Servo amplifier	Rotary servo motor	Linear servo motor (primary side) <sup>(Note 1)</sup>	Direct drive motor
MR-J4W3-222B	HG-KR053(B), 13(B), 23(B) HG-MR053(B), 13(B), 23(B)	LM-U2PAB-05M-0SS0 LM-U2PBB-07M-1SS0	TM-RG2M002C30 <sup>(Note 4)</sup> TM-RU2M002C30 <sup>(Note 4)</sup> TM-RG2M004E30 <sup>(Note 4)</sup> TM-RU2M004E30 <sup>(Note 4)</sup> TM-RFM002C20
MR-J4W3-444B	HG-KR053(B), 13(B), 23(B), 43(B) HG-MR053(B), 13(B), 23(B), 43(B)	LM-H3P2A-07P-BSS0 LM-H3P3A-12P-CSS0 LM-K2P1A-01M-2SS1 LM-U2PAB-05M-0SS0 LM-U2PAD-10M-0SS0 LM-U2PAF-15M-0SS0 LM-U2PBB-07M-1SS0	TM-RG2M002C30 <sup>(Note 4)</sup> TM-RU2M002C30 <sup>(Note 4)</sup> TM-RG2M004E30 <sup>(Note 3, 4)</sup> TM-RU2M004E30 <sup>(Note 3, 4)</sup> TM-RG2M009G30 <sup>(Note 4)</sup> TM-RU2M009G30 <sup>(Note 4)</sup> TM-RFM002C20 TM-RFM004C20

Notes: 1. Models of the linear servo motor primary side are listed in this page. For compatible models of the secondary side, refer to "Combinations of Linear Servo Motor and Servo Amplifier" under section 3 Linear Servo Motor in this catalog.

2. This combination increases the maximum torque from 300% to 400% of the rated torque.

4. This combination increases the rated and maximum torque.

5. TM-RG2M/TM-RU2M series is supported by the servo amplifiers with software version C8 or later.

Servo Amplifiers

Rotary Servo Motors

Linear Servo Motors

Direct Drive Motors

Options/Peripheral Equipment

LVS/Wires

Product List

Precautions

# Servo Amplifiers

## Selection of Power Regeneration Converter Unit, MR-J4-DU\_B\_(-RJ) Drive Unit, and Servo Amplifier

**B B-RJ**

Select a power regeneration converter unit which meets the following conditions. When all the conditions are satisfied, multiple MR-J4-DU\_B\_(-RJ) drive units can be connected to one power regeneration converter unit. When connecting the multiple MR-J4-DU\_B\_(-RJ) drive units, install the drive units in descending order of capacity from the right side of the power regeneration converter unit. Refer to "MR-CV\_ MR-CR55K\_ MR-J4-DU\_B\_(-RJ) MR-J4-DU\_A\_(-RJ) Instruction Manual" for details of the selection.

- (1) Maximum capacity [kW] of MR-J4-DU\_B\_(-RJ) connected to MR-CV\_ ≤ Maximum capacity [kW] of MR-J4-DU\_B\_(-RJ) drivable with MR-CV\_
- (2) Effective value [kW] of total output power of servo motors ≤ Continuous rating [kW] of MR-CV\_
- (3) Maximum value [kW] of total output power of servo motors × 1.2 ≤ Instantaneous maximum rating [kW] of MR-CV\_
- (4) Total widths of MR-J4-DU\_B\_(-RJ) ≤ 800 mm

	MR-CV_ (200 V)						MR-CV_ (400 V)						
	11K	18K	30K	37K	45K	55K	11K4	18K4	30K4	37K4	45K4	55K4	75K4
Maximum capacity of MR-J4-DU_B_(-RJ) drivable with MR-CV_ [kW]	11	15	30	37	37	37	11	15	30	37	45	55	55
Continuous rating [kW]	7.5	11	20	22	22	37	7.5	11	20	25	25	55	55
Instantaneous maximum rating [kW]	39	60	92	101	125	175	39	60	92	101	125	175	180
Total widths of MR-J4-DU_B_(-RJ)	800 mm or shorter												

	MR-J4-DU_ (200 V)						MR-J4-DU_ (400 V)							
	900B	11KB	15KB	22KB	30KB	37KB	900B4	11KB4	15KB4	22KB4	30KB4	37KB4	45KB4	55KB4
Unit width [mm]	150		240		300		150		240			300		

When one unit of MR-J4-DU\_B\_(-RJ) is connected to one power regeneration converter unit, the drive unit is driven at the rated output with the following combinations.

Power regeneration converter unit	Drive unit
MR-CV18K	MR-J4-DU900B(-RJ), MR-J4-DU11KB(-RJ)
MR-CV30K	MR-J4-DU15KB(-RJ)
MR-CV37K	MR-J4-DU22KB(-RJ)
MR-CV55K	MR-J4-DU30KB(-RJ), MR-J4-DU37KB(-RJ)
MR-CV18K4	MR-J4-DU900B4(-RJ), MR-J4-DU11KB4(-RJ)
MR-CV30K4	MR-J4-DU15KB4(-RJ)
MR-CV37K4	MR-J4-DU22KB4(-RJ)
MR-CV55K4	MR-J4-DU30KB4(-RJ), MR-J4-DU37KB4(-RJ), MR-J4-DU45KB4(-RJ), MR-J4-DU55KB4(-RJ)

Refer to "MR-CV\_ MR-CR55K\_ MR-J4-DU\_B\_(-RJ) MR-J4-DU\_A\_(-RJ) Instruction Manual" for the combinations of the power regeneration converter unit and MR-J4-B\_(-RJ) servo amplifier.

**MR-J4-GF/MR-J4-GF-RJ Connections with Peripheral Equipment** (Note 1)

**GF GF-RJ**

Peripheral equipment is connected to MR-J4-GF/MR-J4-GF-RJ as described below. Connectors, cables, options, and other necessary equipment are available so that users can set up the servo amplifier easily and start using it right away.

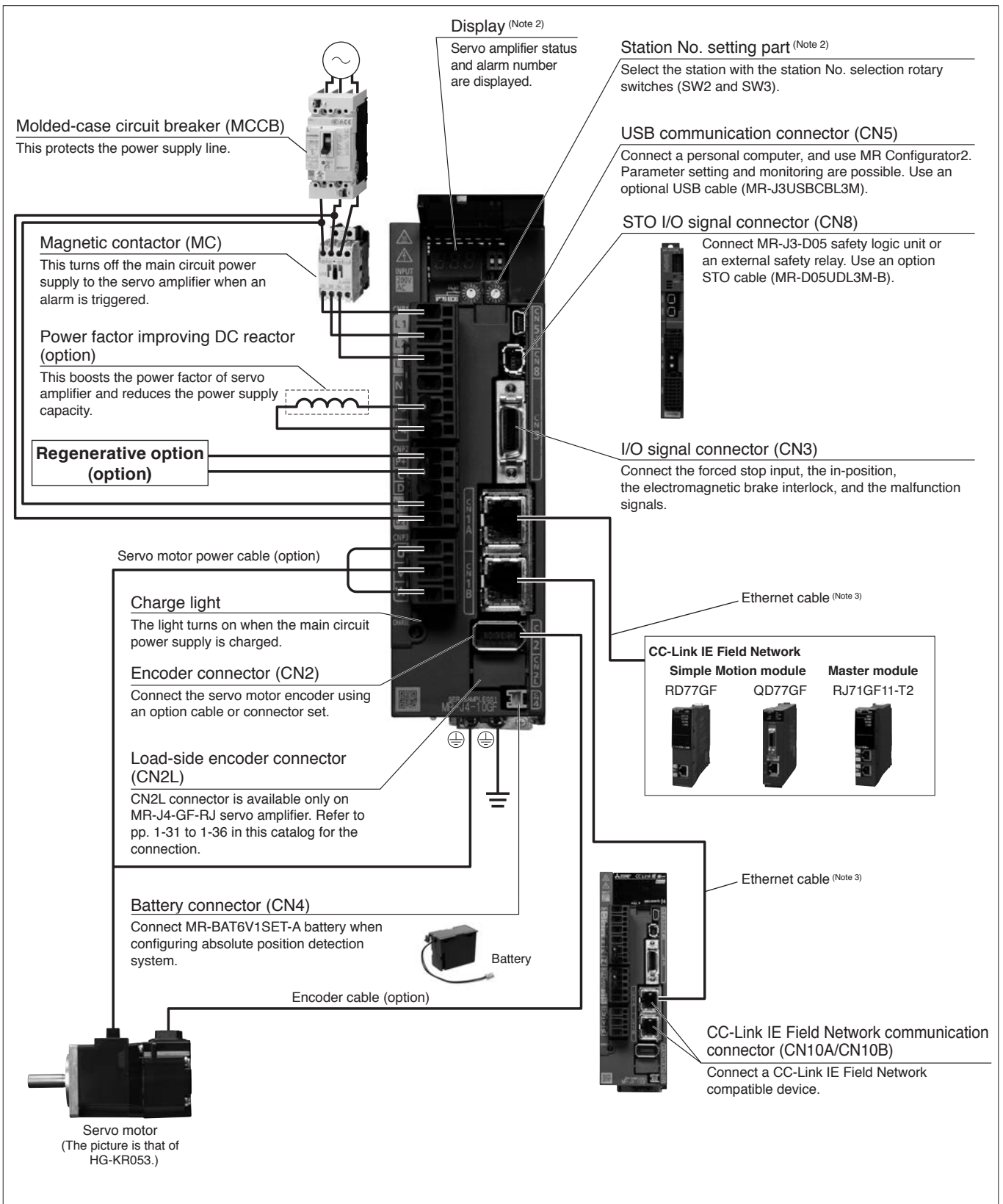

Notes: 1. The connection with the peripheral equipment is an example for MR-J4-350GF/MR-J4-350GF-RJ or smaller servo amplifiers. Refer to "MR-J4-\_GF\_(-RJ) Servo Amplifier Instruction Manual (Motion Mode)" for the actual connections.  
2. This picture shows when the display cover is open.  
3. For specifications of the Ethernet cable, refer to "Ethernet Cable Specifications" on p. 5-31 in this catalog.

Servo Amplifiers  
Rotary Servo Motors  
Linear Servo Motors  
Direct Drive Motors  
Options/Peripheral Equipment  
LV/S/Wires  
Product List  
Precautions

# Servo Amplifiers

## MR-J4-GF(1)/MR-J4-GF(1)-RJ

GF GF-RJ

### (CC-Link IE Field Network Interface (Note 20) Specifications (200 V/100 V)

Servo amplifier model MR-J4-_(-RJ)		10GF	20GF	40GF	60GF	70GF	100GF	200GF	350GF	500GF	700GF	11KGF	15KGF	22KGF	10GF1	20GF1	40GF1		
Output	Rated voltage	3-phase 170 V AC																	
	Rated current [A]	1.1	1.5	2.8	3.2	5.8	6.0	11.0	17.0	28.0	37.0	68.0	87.0	126.0	1.1	1.5	2.8		
Main circuit power supply input	Voltage/frequency (Note 1)	AC input	3-phase or 1-phase 200 V AC to 240 V AC, 50 Hz/60 Hz					3-phase or 1-phase 200 V AC to 240 V AC, 50 Hz/60 Hz (Note 10)		3-phase 200 V AC to 240 V AC, 50 Hz/60 Hz						1-phase 100 V AC to 120 V AC, 50 Hz/60 Hz			
		DC input (Note 12)	283 V DC to 340 V DC																
	Rated current (Note 9) [A]	0.9 (1.5)	1.5 (2.5)	2.6 (4.5)	3.2 (5.0) (Note 8)	3.8 (6.5)	5.0 (10.5)	10.5 (15.8)	16.0	21.7	28.9	46.0	64.0	95.0	3.0	5.0	9.0		
	Permissible voltage fluctuation	AC input	3-phase or 1-phase 170 V AC to 264 V AC					3-phase or 1-phase 170 V AC to 264 V AC (Note 10)		3-phase 170 V AC to 264 V AC						1-phase 85 V AC to 132 V AC			
		DC input (Note 12)	241 V DC to 374 V DC																
	Permissible frequency fluctuation	±5% maximum																	
Control circuit power supply input	Voltage/frequency	AC input	1-phase 200 V AC to 240 V AC, 50 Hz/60 Hz													1-phase 100 V AC to 120 V AC, 50 Hz/60 Hz			
		DC input (Note 12)	283 V DC to 340 V DC																
	Rated current [A]	0.2								0.3				0.4					
	Permissible voltage fluctuation	AC input	1-phase 170 V AC to 264 V AC													1-phase 85 V AC to 132 V AC			
		DC input (Note 12)	241 V DC to 374 V DC																
	Permissible frequency fluctuation	±5% maximum																	
Power consumption [W]	30								45				30						
Interface power supply	24 V DC ± 10% (required current capacity: 0.3 A (including CN8 connector signals))																		
Control method	Sine-wave PWM control/current control method																		
Permissible regenerative power	Built-in regenerative resistor (Note 2, 3) [W]	-	10	10	10	20	20	100	100	130	170	-	-	-	-	10	10		
	External regenerative resistor (standard accessory) (Note 2, 3, 15, 16) [W]	-	-	-	-	-	-	-	-	-	-	500 (800)	850 (1300)	850 (1300)	-	-	-		
Dynamic brake (Note 4)	Built-in										External option (Note 17)			Built-in					
CC-Link IE Field communication cycle (Note 14)	0.5 ms, 1.0 ms, 2.0 ms, 4.0 ms																		
Communication function	USB	Connect a personal computer (MR Configurator2 compatible)																	
Encoder output pulse	Compatible (A/B/Z-phase pulse)																		
Analog monitor	2 channels																		
Positioning mode (Note 18)	Point table method, indexer method																		
Fully closed loop control	MR-J4-GF(1)	Two-wire type communication method																	
	MR-J4-GF(1)-RJ	Two-wire/four-wire type communication method																	
Load-side encoder interface	MR-J4-GF(1)	Mitsubishi Electric high-speed serial communication																	
	MR-J4-GF(1)-RJ	Mitsubishi Electric high-speed serial communication, A/B/Z-phase differential input signal																	
Servo functions	Advanced vibration suppression control II, adaptive filter II, robust filter, auto tuning, one-touch tuning, tough drive function, drive recorder function, machine diagnosis function (including failure prediction (Note 19)), power monitoring function, scale measurement function, super trace control, lost motion compensation function																		
Protective functions	Overcurrent shut-off, regenerative overvoltage shut-off, overload shut-off (electronic thermal), servo motor overheat protection, encoder error protection, regenerative error protection, undervoltage protection, instantaneous power failure protection, overspeed protection, error excessive protection, magnetic pole detection protection, linear servo control fault protection																		

MR-J4-GF(1)/MR-J4-GF(1)-RJ

GF GF-RJ

(CC-Link IE Field Network Interface (Note 20) Specifications (200 V/100 V)

Servo amplifier model MR-J4-_-(-RJ)		10GF	20GF	40GF	60GF	70GF	100GF	200GF	350GF	500GF	700GF	11KGF	15KGF	22KGF	10GF1	20GF1	40GF1
Functional safety		STO (IEC/EN 61800-5-2)															
Safety performance	Satisfied standards (Note 13)	EN ISO 13849-1:2015 Category 3 PL e, IEC 61508 SIL 3, EN IEC 62061 maximum SIL 3, EN 61800-5-2															
	Response performance	8 ms or less (STO input OFF → energy shut-off)															
	Test pulse input (STO) (Note 7)	Test pulse interval: 1 Hz to 25 Hz, test pulse off time: 1 ms maximum															
	Mean time to dangerous failure (MTTFd)	MTTFd ≥ 100 [years] (314a)															
	Diagnostic coverage (DC)	DC = Medium, 97.6 [%]															
	Probability of dangerous Failure per Hour (PFH)	PFH = 6.4 × 10 <sup>-9</sup> [1/h]															
Structure (IP rating)		Natural cooling, open (IP20)				Force cooling, open (IP20)				Force cooling, open (IP20) (Note 5)				Natural cooling, open (IP20)			
Close mounting	3-phase power input	Possible (Note 6)				Not possible				-							
	1-phase power input	Possible (Note 6)				Not possible				Possible (Note 6)							
Environment	Ambient temperature	Operation: 0 °C to 55 °C (non-freezing), storage: -20 °C to 65 °C (non-freezing)															
	Ambient humidity	Operation/storage: 5 %RH to 90 %RH (non-condensing)															
	Ambience	Indoors (no direct sunlight); no corrosive gas, inflammable gas, oil mist or dust															
	Altitude	2000 m or less above sea level (Note 11)															
	Vibration resistance	5.9 m/s <sup>2</sup> at 10 Hz to 55 Hz (directions of X, Y, and Z axes)															
Mass [kg]		1.0	1.0	1.0	1.0	1.4	1.4	2.1	2.3	4.0	6.2	13.4	13.4	18.2	1.0	1.0	1.0

- Notes: 1. Rated output and speed of a rotary servo motor and a direct drive motor; and continuous thrust and maximum speed of a linear servo motor are applicable when the servo amplifier is operated within the specified power supply voltage and frequency.
2. Select the most suitable regenerative option for your system with our drive system sizing software Motorizer.
3. Refer to "Regenerative Option" in this catalog for the permissible regenerative power [W] when a regenerative option is used.
4. When using the dynamic brake, refer to "MR-J4-\_GF\_(-RJ) Servo Amplifier Instruction Manual (Motion Mode)" for the permissible load to motor inertia ratio and the permissible load to mass ratio.
5. Terminal blocks are excluded.
6. When the servo amplifiers are closely mounted, keep the ambient temperature within 0 °C to 45 °C, or use the servo amplifiers at 75% or less of the effective load ratio.
7. The test pulse is a signal for the external circuit to perform self-diagnosis by turning off the signals to the servo amplifier instantaneously at regular intervals.
8. The rated current is 2.9 A when the servo amplifier is used with a 3-phase power supply and combined with UL or CSA compliant servo motor.
9. The value in brackets indicates the rated current when a 1-phase power supply input is used.
10. When a 1-phase 200 V AC to 240 V AC power supply is used, use the servo amplifiers at 75% or less of the effective load ratio.
11. Refer to "MR-J4-\_GF\_(-RJ) Servo Amplifier Instruction Manual (Motion Mode)" for the restrictions when using the servo amplifiers at altitude exceeding 1000 m and up to 2000 m above sea level.
12. DC power input is supported by MR-J4-\_GF-RJ. For a connection example of power supply circuit with DC input, refer to "MR-J4-\_GF\_(-RJ) Servo Amplifier Instruction Manual (Motion Mode)".
13. The safety level depends on the setting value of [Pr. PF18 STO diagnosis error detection time] and whether or not STO input diagnosis is performed by TOFB output. Refer to "MR-J4-\_GF\_(-RJ) Servo Amplifier Instruction Manual (Motion Mode)" for details.
14. The command communication cycle depends on the controller specifications and the number of axes connected.
15. The value in brackets is applicable when cooling fans (two units of 92 mm × 92 mm, minimum air flow: 1.0 m<sup>3</sup>/min) are installed, and then [Pr. PA02] is changed.
16. Servo amplifiers without an enclosed regenerative resistor are also available. Refer to "Model Designation for 1-Axis Servo Amplifier" in this catalog for details.
17. Use an external dynamic brake (option) with the servo amplifier. Without the external dynamic brake, a servo motor does not stop immediately at emergency stop and falls in free-run status, causing an accident such as machine collision, etc. Take measures to ensure safety on the entire system when not using the dynamic brake.
18. Positioning mode is supported by MR-J4-\_GF(-RJ) servo amplifiers with software version B3 or later.
19. The failure prediction function is supported by MR-J4-\_GF(-RJ) servo amplifiers with software version A3 or later.
20. These models also support CC-Link IE Field Network Basic. To use this network, switch the network setting with the slide switches. Refer to "MR-J4-\_GF\_(-RJ) Servo Amplifier Instruction Manual (CC-Link IE Field Network Basic)" for CC-Link IE Field Network Basic.

Servo Amplifiers  
Rotary Servo Motors  
Linear Servo Motors  
Direct Drive Motors  
Options/Peripheral Equipment  
LV5/Wires  
Product List  
Precautions

# Servo Amplifiers

## MR-J4-GF4/MR-J4-GF4-RJ

GF GF-RJ

### (CC-Link IE Field Network Interface) Specifications (400 V)

Servo amplifier model MR-J4-_(-RJ)		60GF4	100GF4	200GF4	350GF4	500GF4	700GF4	11KGF4	15KGF4	22KGF4	
Output	Rated voltage	3-phase 323 V AC									
	Rated current [A]	1.5	2.8	5.4	8.6	14.0	17.0	32.0	41.0	63.0	
Main circuit power supply input	Voltage/frequency <sup>(Note 1)</sup>	3-phase 380 V AC to 480 V AC, 50 Hz/60 Hz									
	Rated current [A]	1.4	2.5	5.1	7.9	10.8	14.4	23.1	31.8	47.6	
	Permissible voltage fluctuation	3-phase 323 V AC to 528 V AC									
	Permissible frequency fluctuation	±5% maximum									
Control circuit power supply input	Voltage/frequency	1-phase 380 V AC to 480 V AC, 50 Hz/60 Hz									
	Rated current [A]	0.1				0.2					
	Permissible voltage fluctuation	1-phase 323 V AC to 528 V AC									
	Permissible frequency fluctuation	±5% maximum									
	Power consumption [W]	30				45					
Interface power supply		24 V DC ± 10% (required current capacity: 0.3 A (including CN8 connector signals))									
Control method		Sine-wave PWM control/current control method									
Permissible regenerative power	Built-in regenerative resistor <sup>(Note 2, 3)</sup> [W]	15	15	100	100	130 <sup>(Note 7)</sup>	170 <sup>(Note 7)</sup>	-	-	-	
	External regenerative resistor (standard accessory) <sup>(Note 2, 3, 12, 13)</sup> [W]	-	-	-	-	-	-	500 (800)	850 (1300)	850 (1300)	
Dynamic brake <sup>(Note 4)</sup>		Built-in						External option <sup>(Note 11)</sup>			
CC-Link IE Field communication cycle <sup>(Note 10)</sup>		0.5 ms, 1.0 ms, 2.0 ms, 4.0 ms									
Communication function		USB Connect a personal computer (MR Configurator2 compatible)									
Encoder output pulse		Compatible (A/B/Z-phase pulse)									
Analog monitor		2 channels									
Positioning mode		Point table method, indexer method									
Fully closed loop control	MR-J4-GF4	Two-wire type communication method									
	MR-J4-GF4-RJ	Two-wire/four-wire type communication method									
Load-side encoder interface	MR-J4-GF4	Mitsubishi Electric high-speed serial communication									
	MR-J4-GF4-RJ	Mitsubishi Electric high-speed serial communication, A/B/Z-phase differential input signal									
Servo functions		Advanced vibration suppression control II, adaptive filter II, robust filter, auto tuning, one-touch tuning, tough drive function, drive recorder function, machine diagnosis function (including failure prediction <sup>(Note 15)</sup> ), power monitoring function, scale measurement function, super trace control, lost motion compensation function									
Protective functions		Overcurrent shut-off, regenerative overvoltage shut-off, overload shut-off (electronic thermal), servo motor overheat protection, encoder error protection, regenerative error protection, undervoltage protection, instantaneous power failure protection, overspeed protection, error excessive protection, magnetic pole detection protection, linear servo control fault protection									
Functional safety		STO (IEC/EN 61800-5-2)									
Safety performance	Satisfied standards <sup>(Note 9)</sup>	EN ISO 13849-1:2015 Category 3 PL e, IEC 61508 SIL 3, EN IEC 62061 maximum SIL 3, EN 61800-5-2									
	Response performance	8 ms or less (STO input OFF → energy shut-off)									
	Test pulse input (STO) <sup>(Note 6)</sup>	Test pulse interval: 1 Hz to 25 Hz, test pulse off time: 1 ms maximum									
	Mean time to dangerous failure (MTTFd)	MTTFd ≥ 100 [years] (314a)									
	Diagnostic coverage (DC)	DC = Medium, 97.6 [%]									
	Probability of dangerous Failure per Hour (PFH)	PFH = 6.4 × 10 <sup>-9</sup> [1/h]									
Structure (IP rating)		Natural cooling, open (IP20)	Force cooling, open (IP20)			Force cooling, open (IP20) <sup>(Note 5)</sup>					
Close mounting		Not possible									
Environment	Ambient temperature	Operation: 0 °C to 55 °C (non-freezing), storage: -20 °C to 65 °C (non-freezing)									
	Ambient humidity	Operation/storage: 5 %RH to 90 %RH (non-condensing)									
	Ambience	Indoors (no direct sunlight); no corrosive gas, inflammable gas, oil mist or dust									
	Altitude	2000 m or less above sea level <sup>(Note 8)</sup>									
	Vibration resistance	5.9 m/s <sup>2</sup> at 10 Hz to 55 Hz (directions of X, Y, and Z axes)									
Mass [kg]		1.7	1.7	2.1	3.6	4.3	6.5	13.4	13.4	18.2	

**MR-J4-GF4/MR-J4-GF4-RJ**

**GF GF-RJ**

**(CC-Link IE Field Network Interface) Specifications (400 V)**

- Notes: 1. Rated output and speed of a rotary servo motor, and continuous thrust and maximum speed of a linear servo motor are applicable when the servo amplifier is operated within the specified power supply voltage and frequency.
2. Select the most suitable regenerative option for your system with our drive system sizing software Motorizer.
3. Refer to "Regenerative Option" in this catalog for the permissible regenerative power [W] when a regenerative option is used.
4. When using the dynamic brake, refer to "MR-J4-\_GF\_(-RJ) Servo Amplifier Instruction Manual (Motion Mode)" for the permissible load to motor inertia ratio and the permissible load to mass ratio.
5. Terminal blocks are excluded.
6. The test pulse is a signal for the external circuit to perform self-diagnosis by turning off the signals to the servo amplifier instantaneously at regular intervals.
7. The servo amplifier built-in regenerative resistor is compatible with the maximum torque deceleration when the servo motor is used within the rated speed and the recommended load to motor inertia ratio. Contact your local sales office if the operating motor speed or the load to motor inertia ratio exceeds the rated speed or the recommended ratio.
8. Refer to "MR-J4-\_GF\_(-RJ) Servo Amplifier Instruction Manual (Motion Mode)" for the restrictions when using the servo amplifiers at altitude exceeding 1000 m and up to 2000 m above sea level.
9. The safety level depends on the setting value of [Pr. PF18 STO diagnosis error detection time] and whether or not STO input diagnosis is performed by TOFB output. Refer to "MR-J4-\_GF\_(-RJ) Servo Amplifier Instruction Manual (Motion Mode)" for details.
10. The command communication cycle depends on the controller specifications and the number of axes connected.
11. Use an external dynamic brake (option) with the servo amplifier. Without the external dynamic brake, a servo motor does not stop immediately at emergency stop and falls in free-run status, causing an accident such as machine collision, etc. Take measures to ensure safety on the entire system when not using the dynamic brake.
12. The value in brackets is applicable when cooling fans (two units of 92 mm × 92 mm, minimum air flow: 1.0 m<sup>3</sup>/min) are installed, and then [Pr. PA02] is changed.
13. Servo amplifiers without an enclosed regenerative resistor are also available. Refer to "Model Designation for 1-Axis Servo Amplifier" in this catalog for details.
14. Positioning mode is supported by MR-J4-\_GF4(-RJ) servo amplifiers with software version B3 or later.
15. The failure prediction function is supported by MR-J4-\_GF4(-RJ) servo amplifiers with software version A3 or later.

Servo Amplifiers

Rotary Servo Motors

Linear Servo Motors

Direct Drive Motors

Options/Peripheral Equipment

LVS/Wires

Product List

Precautions

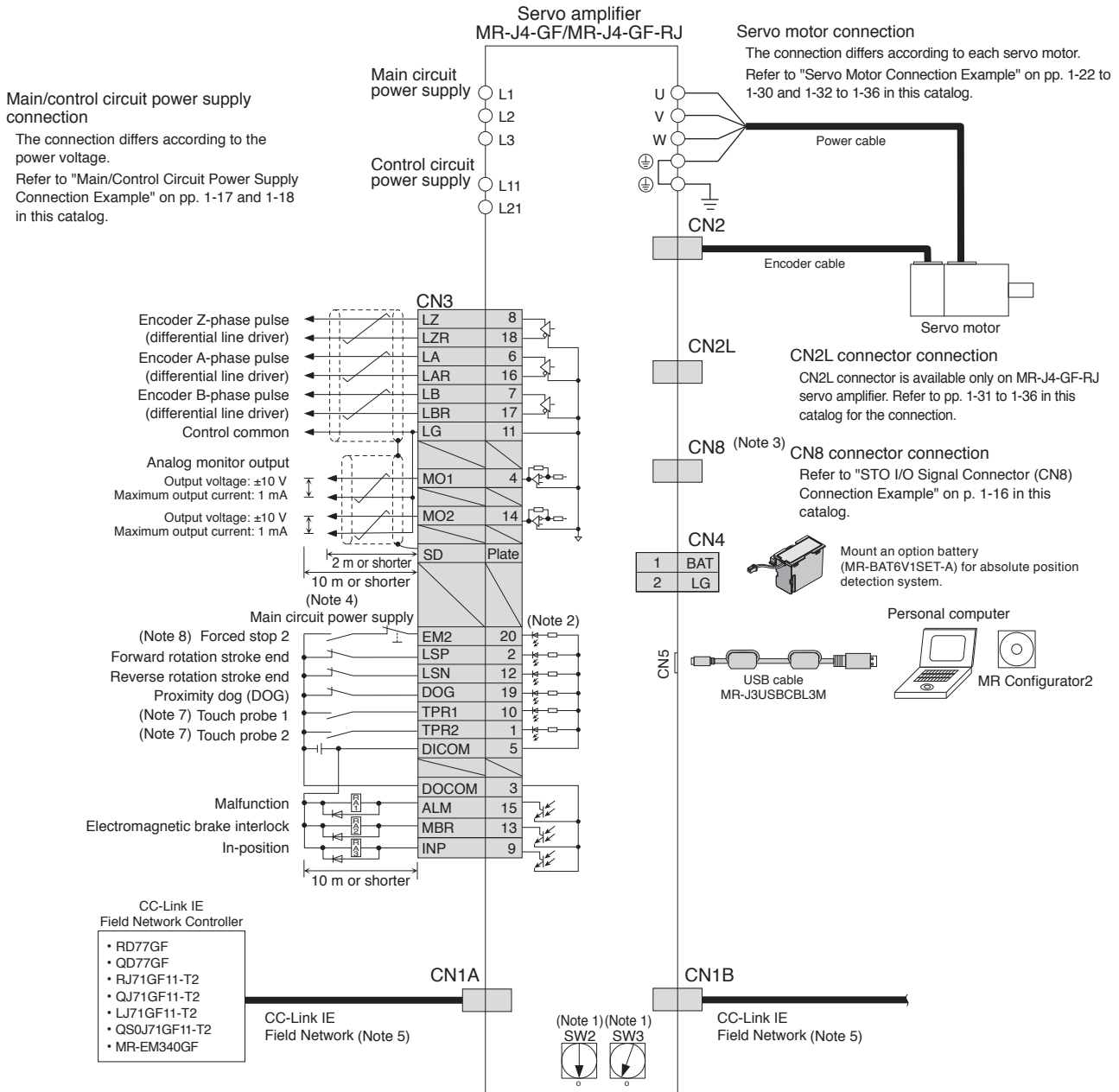

- Notes: 1. Up to 120 stations are set with a combination of the station No. selection rotary switches (SW2 and SW3). Note that the number of the connectable stations depends on the controller specifications.
2. This is for sink wiring. Source wiring is also possible.
3. Be sure to attach a short-circuit connector supplied with the servo amplifier when the STO function is not used.
4. To prevent an unexpected restart of the servo amplifier, create a circuit to turn off EM2 (Forced stop 2) when the main circuit power is turned off.
5. When branching off CC-Link IE Field Network (synchronous communication function) with a switching hub, use N2ZMHG-T8F2 (Mitsubishi Electric Corporation) or DT135TXA (Mitsubishi Electric System & Service Co., Ltd.).
6. This standard wiring diagram is common for 200 V AC and 400 V AC type servo amplifiers. The connection is the same for positioning mode.
7. TPR1 (touch probe 1) and TPR2 (touch probe 2) are available only with MR-J4-GF-RJ.
8. The forced stop signal is issued for the servo amplifier. For overall system, apply the emergency stop on the controller side.



Be sure to read through Instruction Manual for the actual wiring and use. Use the equipment after you have a full knowledge of the equipment, safety information and instructions.



STO I/O Signal Connector (CN8) Connection Example

GF GF-RJ B B-RJ WB A A-RJ

●When used with MR-J3-D05

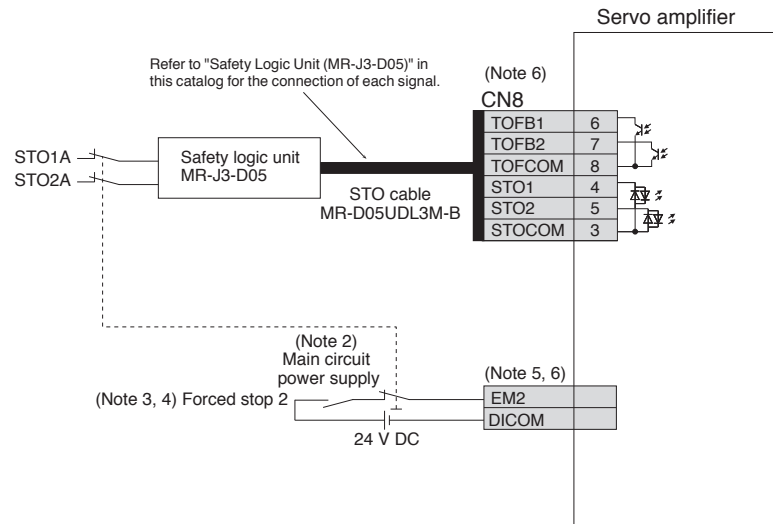

●When using a safety door

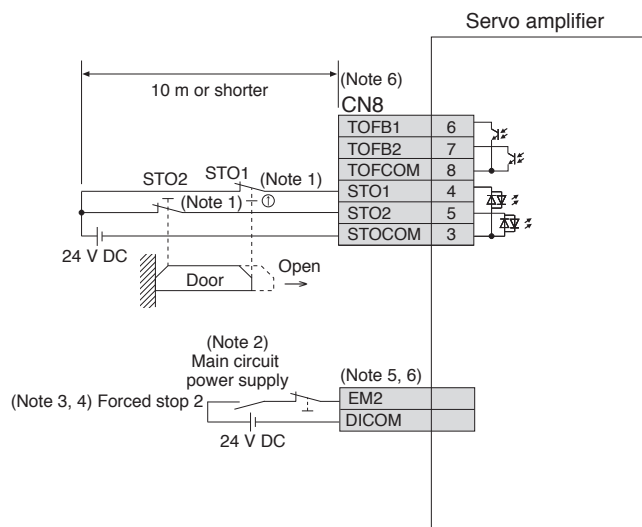

- Notes: 1. When using the STO function, turn off STO1 and STO2 at the same time. Be sure to turn off STO1 and STO2 after the servo motor stops in servo-off state or after the servo motor is forcibly stopped with deceleration by turning off EM2 (Forced stop 2).  
 2. To prevent an unexpected restart of the servo amplifier, create a circuit to turn off EM2 (Forced stop 2) when the main circuit power is turned off.  
 3. If the controller does not have a forced stop function, install a forced stop 2 switch (normally closed contact).  
 4. Turn on EM2 (Forced stop 2) before starting the operation.  
 5. The connector and the pin numbers for each signal vary depending on the servo amplifier. Refer to the standard wiring diagram example for relevant servo amplifier in this catalog for details.  
 6. This is for source wiring. Sink wiring is also possible.

**!** Be sure to read through Instruction Manual for the actual wiring and use. Use the equipment after you have a full knowledge of the equipment, safety information and instructions.

Servo Amplifiers  
 Rotary Servo Motors  
 Linear Servo Motors  
 Direct Drive Motors  
 Options/Peripheral Equipment  
 LV5/Wires  
 Product List  
 Precautions

# Servo Amplifiers

## Main/Control Circuit Power Supply Connection Example (Note 7)

GF GF-RJ B B-RJ A A-RJ

### ● For 1-phase 100 V AC

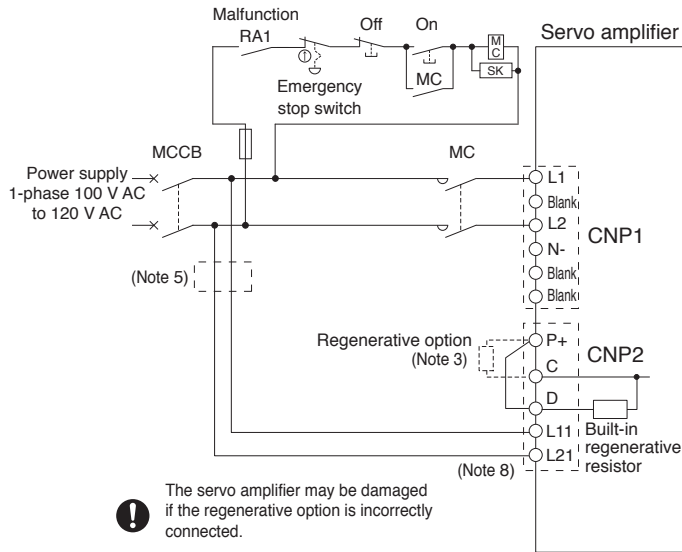

### ● For 1-phase 200 V AC

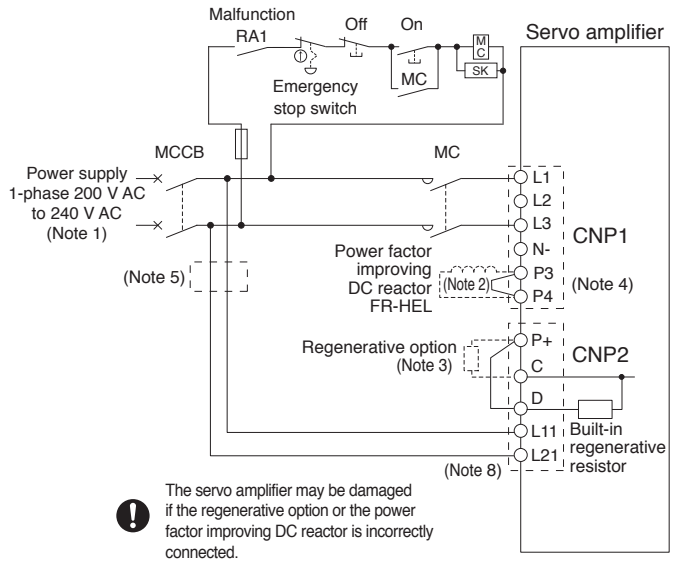

### ● For 3-phase 200 V AC, 3.5 kW or smaller

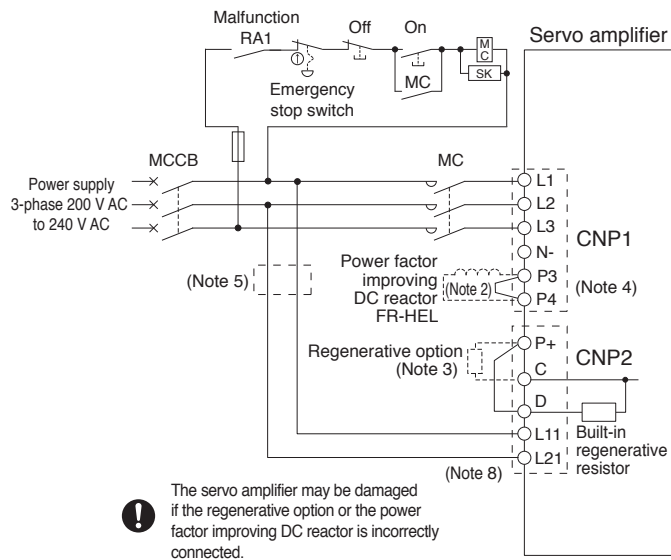

### ● For 3-phase 400 V AC, 3.5 kW or smaller

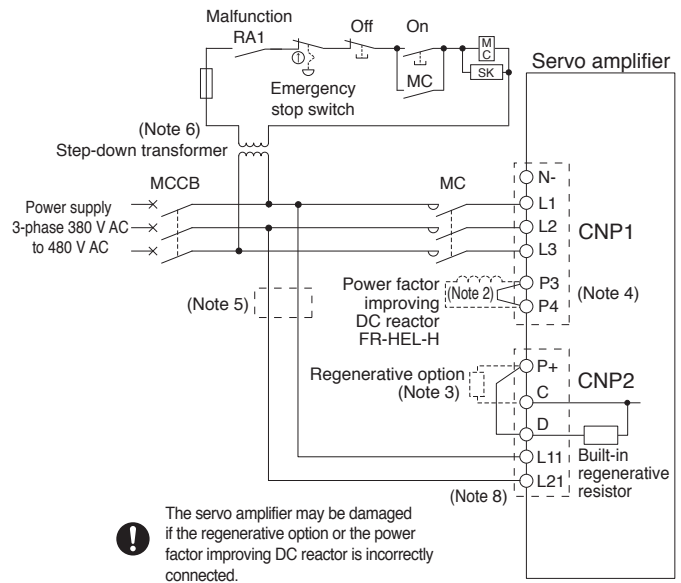

- Notes: 1. For 1-phase 200 V AC to 240 V AC, connect the power supply to L1 and L3 terminals. Do not connect anything to L2. The connections are different from MR-J3 series servo amplifiers. Be careful not to make a connection error when replacing MR-J3 with MR-J4.
2. Disconnect a short-circuit bar between P3 and P4 when using the power factor improving DC reactor.
3. Disconnect a short-circuit bar between P+ and D when connecting the regenerative option externally.
4. MR-J4 series servo amplifiers have P3 and P4 in the upstream of the inrush current suppression circuit. They are different from P1 and P2 (downstream of the inrush current suppression circuit) of MR-J3 series servo amplifiers. Refer to relevant Servo Amplifier Instruction Manual for details.
5. When wires used for L11 and L21 are thinner than those for L1, L2, and L3, use a molded-case circuit breaker or a fuse. Refer to relevant Servo Amplifier Instruction Manual for details.
6. A step-down transformer is required if coil voltage of the magnetic contactor is in 200 V class.
7. To turn on/off the main circuit power supply by a DC power supply, refer to relevant Servo Amplifier Instruction Manual for a connection example of the power supply circuit.
8. Do not ground the servo amplifier between L11 and L21 even when the control circuit power supply is separated from the main circuit power supply using an uninterruptible power supply (UPS) or an isolation transformer.



Be sure to read through Instruction Manual for the actual wiring and use. Use the equipment after you have a full knowledge of the equipment, safety information and instructions.

## Main/Control Circuit Power Supply Connection Example (Note 9)

GF GF-RJ B B-RJ A A-RJ

● For 3-phase 200 V AC, 5 kW

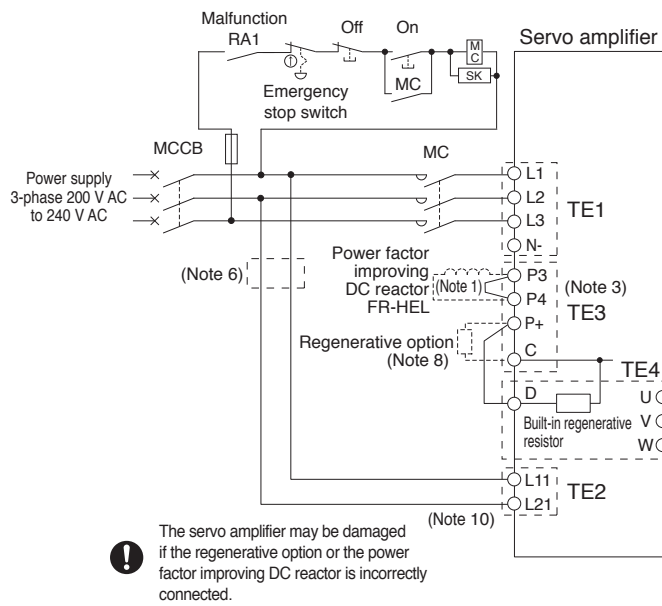

● For 3-phase 400 V AC, 5 kW

● For 3-phase 200 V AC/400 V AC, 7 kW

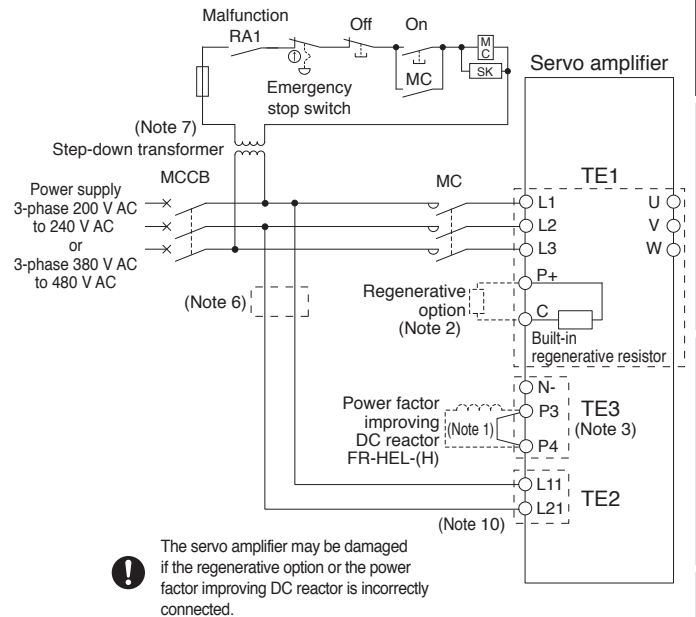

● For 3-phase 200 V AC/400 V AC, 11 kW to 22 kW

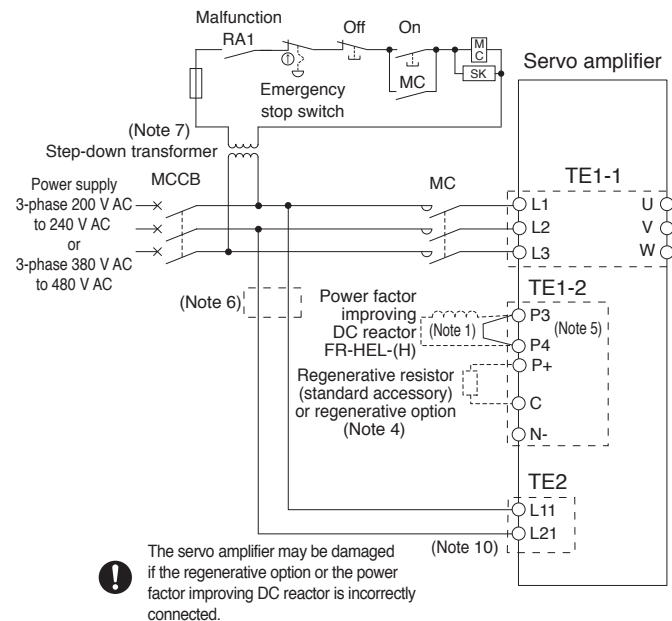

- Notes:
1. Disconnect a short-circuit bar between P3 and P4 when using the power factor improving DC reactor.
  2. Disconnect the wires for the built-in regenerative resistor (P+ and C) when connecting the regenerative option externally.
  3. MR-J4 series servo amplifiers have P3 and P4 in the upstream of the inrush current suppression circuit. They are different from P1 and P2 (downstream of the inrush current suppression circuit) of MR-J3 series servo amplifiers. Refer to relevant Servo Amplifier Instruction Manual for details.
  4. MR-J4-11KGF/\_B/\_A\_ or larger servo amplifiers do not have a built-in regenerative resistor.
  5. MR-J4 series servo amplifiers have P3 and P4 in the upstream of the inrush current suppression circuit. They are different from P1 and P (downstream of the inrush current suppression circuit) of MR-J3 series servo amplifiers. Refer to relevant Servo Amplifier Instruction Manual for details.
  6. When wires used for L11 and L21 are thinner than those for L1, L2, and L3, use a molded-case circuit breaker or a fuse. Refer to relevant Servo Amplifier Instruction Manual for details.
  7. A step-down transformer is required if the servo amplifier is in 400 V class, and coil voltage of the magnetic contactor is in 200 V class.
  8. Disconnect a short-circuit bar between P+ and D when connecting the regenerative option externally.
  9. To turn on/off the main circuit power supply by a DC power supply, refer to relevant Servo Amplifier Instruction Manual for a connection example of the power supply circuit.
  10. Do not ground the servo amplifier between L11 and L21 even when the control circuit power supply is separated from the main circuit power supply using an uninterruptible power supply (UPS) or an isolation transformer.

Be sure to read through Instruction Manual for the actual wiring and use. Use the equipment after you have a full knowledge of the equipment, safety information and instructions.

## Main/Control Circuit Power Supply Connection Example (Note 10)

B B-RJ

● For connecting MR-CV\_ and MR-J4-DU\_B(-RJ) (one-axis connection)

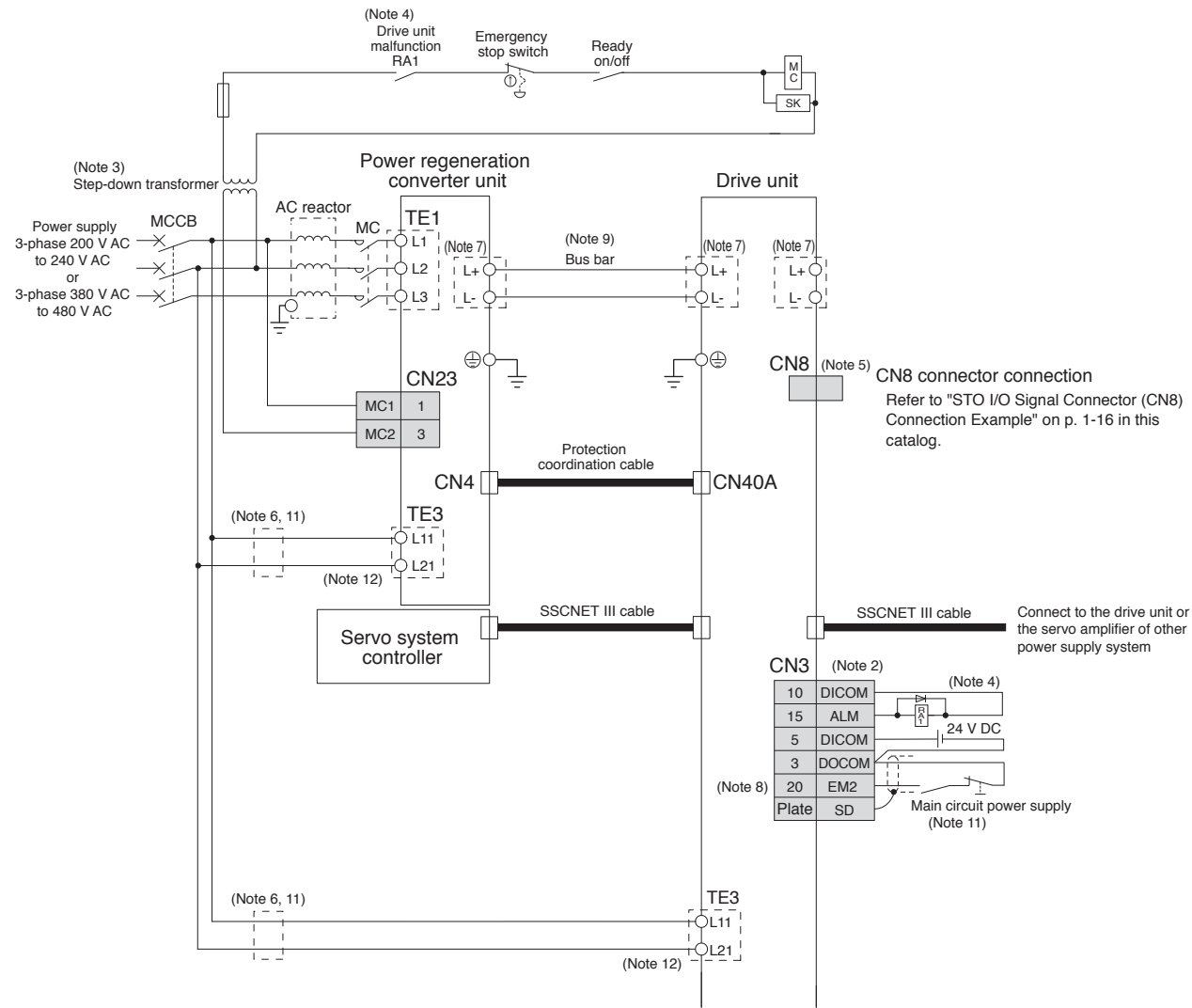

- Notes:
1. To prevent an unexpected restart of the drive unit, create a circuit to turn off EM2 (Forced stop 2) when the main circuit power is turned off.
  2. This is for sink wiring. Source wiring is also possible.
  3. A step-down transformer is required if the power regeneration converter unit is in 400 V class, and coil voltage of the magnetic contactor is in 200 V class.
  4. Create a sequence that shuts off the main circuit power when an alarm occurs.
  5. Be sure to attach a short-circuit connector supplied with the drive unit when the STO function is not used.
  6. Install an overcurrent protection device (molded-case circuit breaker, fuse, etc.) to protect the branch circuit.
  7. Terminal varies depending on the capacity of the power regeneration converter unit and the drive unit. Refer to "MR-CV\_ Power Regeneration Converter Unit Dimensions" and "MR-J4-DU\_B/MR-J4-DU\_B-RJ Dimensions" in this catalog.
  8. To stop the servo motor by forcibly decelerating with EM2, parameter setting is required. Refer to "MR-CV\_ MR-CR55K\_MR-J4-DU\_B(-RJ) MR-J4-DU\_A(-RJ) Instruction Manual" for details.
  9. The bus bar varies depending on the combination of the power regeneration converter unit and the drive unit. Refer to "Bus Bar" in this catalog for details.
  10. This example is for when magnetic contactor drive output is enabled.
  11. The control circuit power supply (L11/L21) can be connected by passing wiring. Refer to "MR-CV\_ MR-CR55K\_MR-J4-DU\_B(-RJ) MR-J4-DU\_A(-RJ) Instruction Manual" for details.
  12. Do not ground the servo amplifier between L11 and L21 even when the control circuit power supply is separated from the main circuit power supply using an uninterruptible power supply (UPS) or an isolation transformer.



Be sure to read through Instruction Manual for the actual wiring and use. Use the equipment after you have a full knowledge of the equipment, safety information and instructions.

Main/Control Circuit Power Supply Connection Example (Note 11)

B B-RJ

● For connecting MR-CV\_ and MR-J4-DU\_B(-RJ) (multi-axis connection)

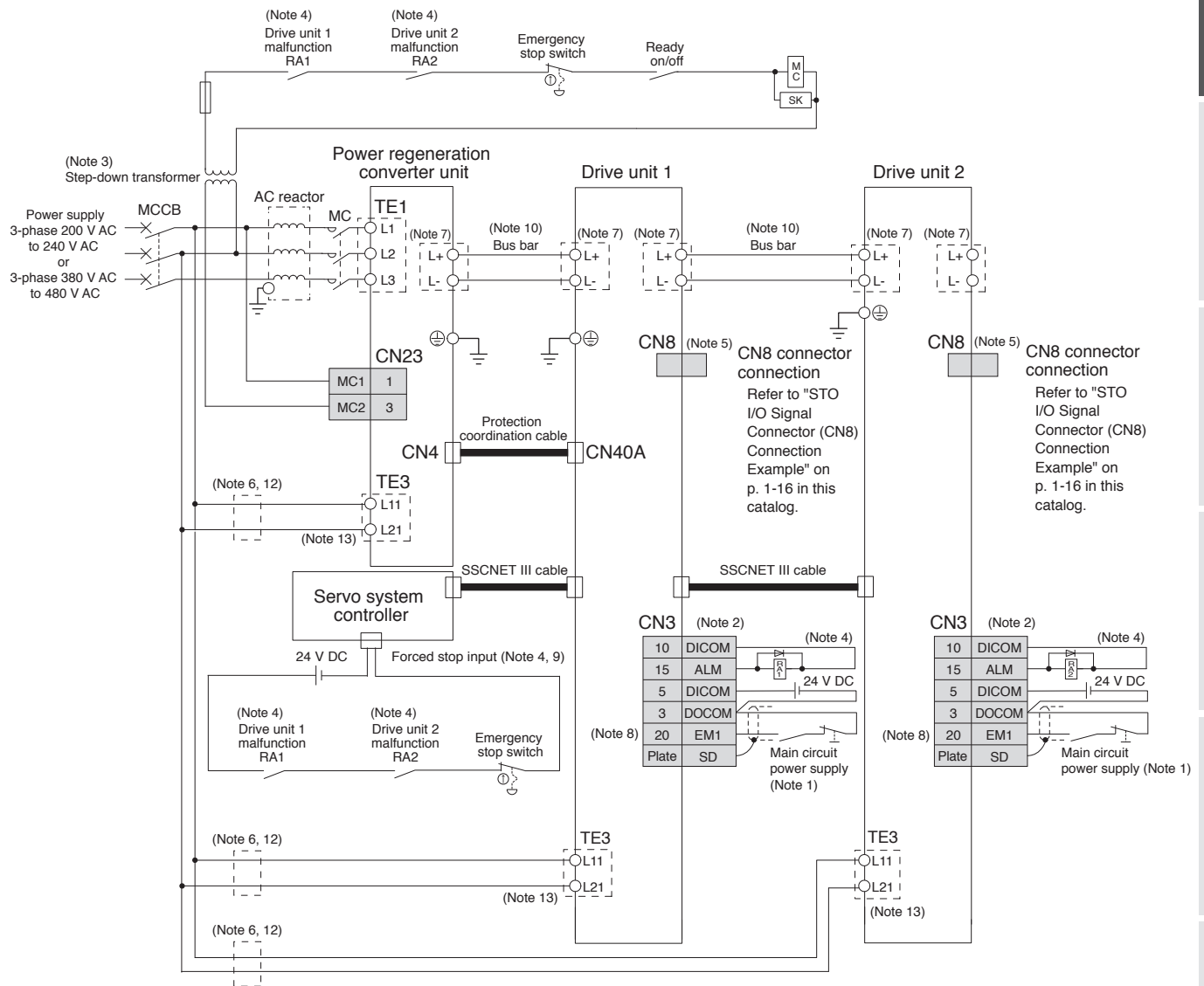

- Notes: 1. To prevent an unexpected restart of the drive unit, create a circuit to turn off EM1 (Forced stop 1) when the main circuit power is turned off.  
 2. This is for sink wiring. Source wiring is also possible.  
 3. A step-down transformer is required if the power regeneration converter unit is in 400 V class, and coil voltage of the magnetic contactor is in 200 V class.  
 4. When connecting multiple drive units, create a sequence in which the servo system controller stops all axes and a sequence that shuts off the main circuit power if an alarm occurs on one axis.  
 5. Be sure to attach a short-circuit connector supplied with the drive unit when the STO function is not used.  
 6. Install an overcurrent protection device (molded-case circuit breaker, fuse, etc.) to protect the branch circuit.  
 7. Terminal varies depending on the capacity of the power regeneration converter unit and the drive unit. Refer to "MR-CV\_ Power Regeneration Converter Unit Dimensions" and "MR-J4-DU\_B/MR-J4-DU\_B(-RJ) Dimensions" in this catalog.  
 8. To stop the servo motors by forcibly decelerating with EM1, parameter setting is required. Refer to "MR-J4\_ B\_(-RJ) Servo Amplifier Instruction Manual" for details.  
 9. Refer to the controller instruction manuals for the forced stop input of the servo system controller.  
 10. The bus bar varies depending on the combination of the power regeneration converter unit and the drive unit. Refer to "Bus Bar" in this catalog for details.  
 11. This example is for when magnetic contactor drive output is enabled.  
 12. The control circuit power supply (L11/L21) can be connected by passing wiring. Refer to "MR-CV\_ MR-CR55K\_ MR-J4-DU\_B\_(-RJ) MR-J4-DU\_A\_(-RJ) Instruction Manual" for details.  
 13. Do not ground the servo amplifier between L11 and L21 even when the control circuit power supply is separated from the main circuit power supply using an uninterruptible power supply (UPS) or an isolation transformer.

**!** Be sure to read through Instruction Manual for the actual wiring and use. Use the equipment after you have a full knowledge of the equipment, safety information and instructions.

Servo Amplifiers  
 Rotary Servo Motors  
 Linear Servo Motors  
 Direct Drive Motors  
 Options/Peripheral Equipment  
 LV5/Wires  
 Product List  
 Precautions

# Servo Amplifiers

## Main/Control Circuit Power Supply Connection Example (Note 11)

**B B-RJ A A-RJ**

● For connecting MR-CR\_ and MR-J4-DU\_B(-RJ)/MR-J4-DU\_A(-RJ) (3-phase 200 V AC/400 V AC, 30 kW or larger)

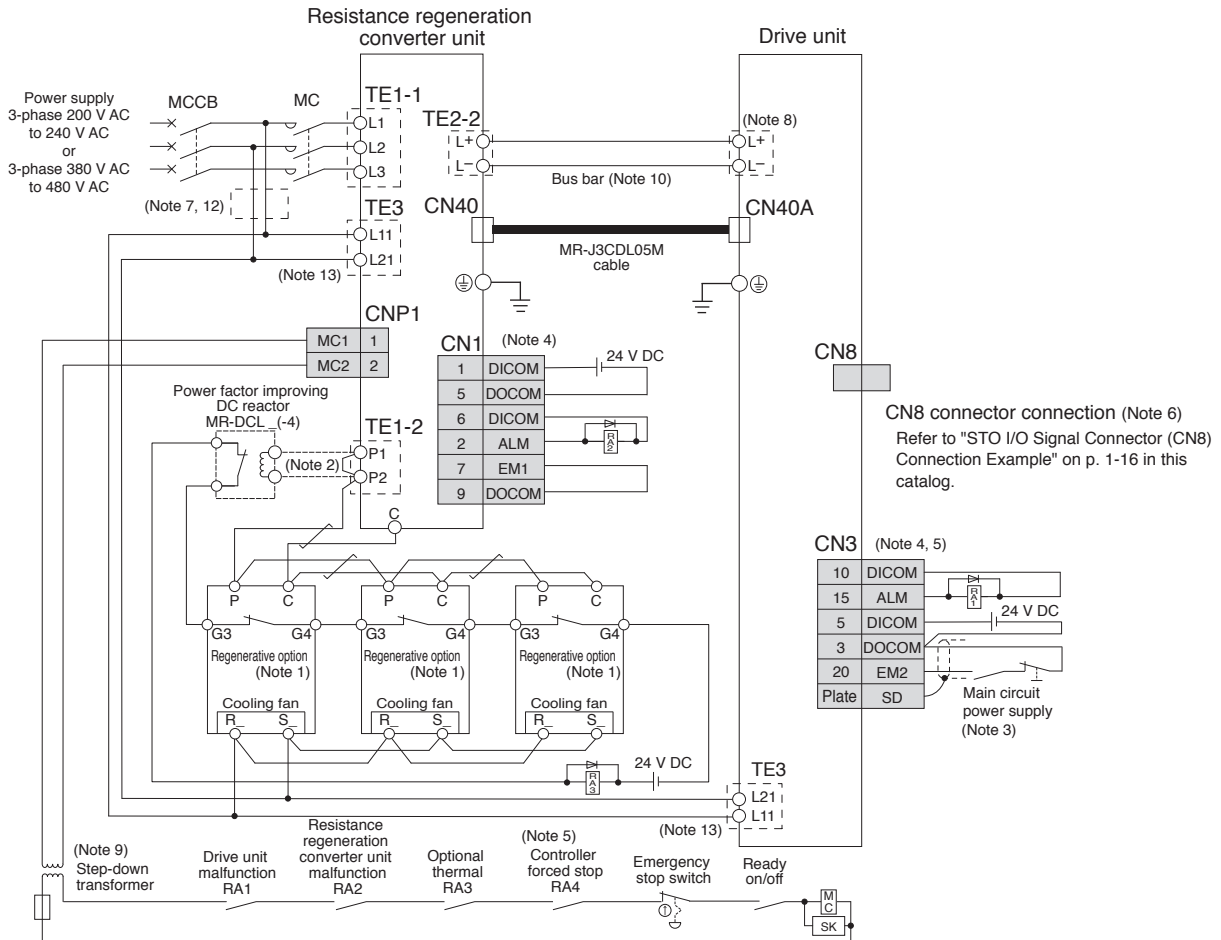

- Notes: 1. This connection is applicable when MR-RB137 (for 200 V) or MR-RB13V-4 (for 400 V) is used. Note that three units of MR-RB137 or MR-RB13V-4 are required for each resistance regeneration converter unit. (Permissible regenerative power: 3900 W)
2. Disconnect a short-circuit bar between P1 and P2 when using the power factor improving DC reactor.
3. To prevent an unexpected restart of the drive unit, create a circuit to turn off EM2 (Forced stop 2) when the main circuit power is turned off.
4. This is for sink wiring. Source wiring is also possible.
5. This connection is applicable for MR-J4-DU\_B(-RJ)/MR-J4-DU\_B4(-RJ). For MR-J4-DU\_A(-RJ)/MR-J4-DU\_A4(-RJ), refer to "MR-CV\_ MR-CR55K\_ MR-J4-DU\_B\_(-RJ) MR-J4-DU\_A\_(-RJ) Instruction Manual."
6. Be sure to attach a short-circuit connector supplied with the drive unit when the STO function is not used.
7. Install an overcurrent protection device (molded-case circuit breaker, fuse, etc.) to protect the branch circuit.
8. Terminal varies depending on the drive unit capacities. Refer to the dimensions of the relevant drive unit in this catalog for details.
9. A step-down transformer is required if the resistance regeneration converter unit is in 400 V class, and coil voltage of the magnetic contactor is in 200 V class.
10. A bus bar is attached to 30 kW or larger drive units.
11. This example is for when magnetic contactor drive output is enabled.
12. The control circuit power supply (L11/L21) can be connected by passing wiring. Refer to "MR-CV\_ MR-CR55K\_ MR-J4-DU\_B\_(-RJ) MR-J4-DU\_A\_(-RJ) Instruction Manual" for details.
13. Do not ground the servo amplifier between L11 and L21 even when the control circuit power supply is separated from the main circuit power supply using an uninterruptible power supply (UPS) or an isolation transformer.



Be sure to read through Instruction Manual for the actual wiring and use. Use the equipment after you have a full knowledge of the equipment, safety information and instructions.

**Servo Motor Connection Example (Rotary Servo Motor)**  
**Semi Closed Loop Control System with MR-J4-GF/MR-J4-B/MR-J4-A**

GF B A

● For HG-KR/HG-MR series

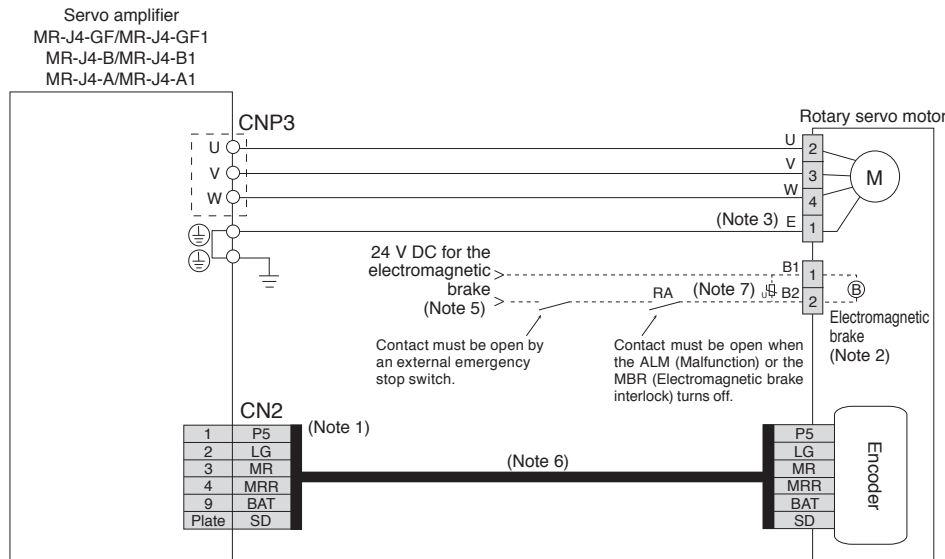

● For HG-SR/HG-JR (9 kW or smaller) series

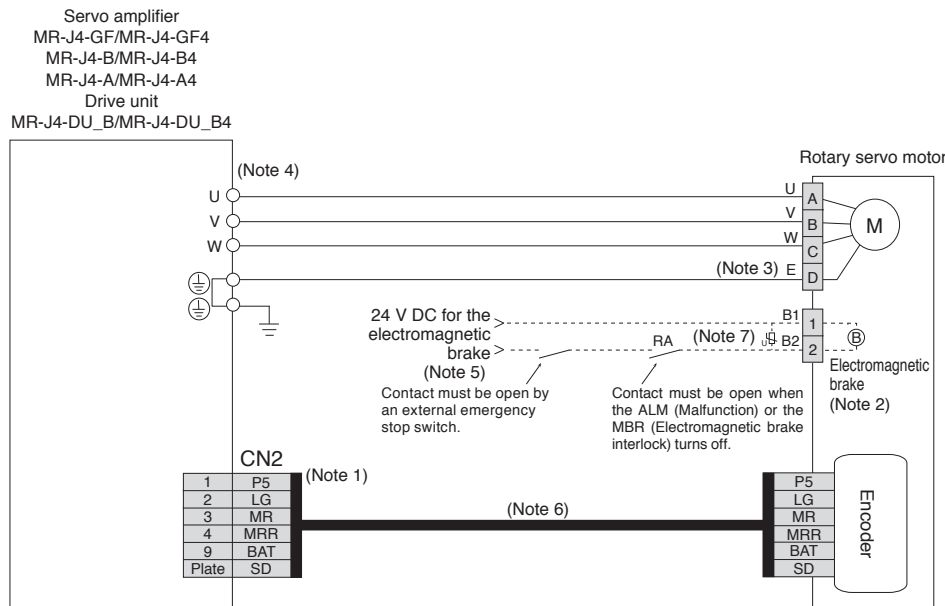

- Notes: 1. The signals shown are applicable when using a two-wire type encoder cable. Four-wire type is also compatible.  
 2. This is for the servo motor with electromagnetic brake. The electromagnetic brake terminals (B1, B2) do not have polarity.  
 3. Connect the grounding wire to the cabinet protective earth (PE) terminal via the servo amplifier for grounding the servo motor.  
 4. Connector or terminal varies depending on the servo amplifier capacities. Refer to the dimensions of the relevant servo amplifier in this catalog for details.  
 5. Do not use the 24 V DC interface power supply for the electromagnetic brake. Provide a dedicated power supply to the electromagnetic brake.  
 6. Encoder cable is available as an option. Refer to "Servo Motor Instruction Manual (Vol. 3)" when fabricating the cables.  
 7. Be sure to install a surge absorber between B1 and B2.

**!** Be sure to read through Instruction Manual for the actual wiring and use. Use the equipment after you have a full knowledge of the equipment, safety information and instructions.

Servo Amplifiers  
 Rotary Servo Motors  
 Linear Servo Motors  
 Direct Drive Motors  
 Options/Peripheral Equipment  
 LV5/Wires  
 Product List  
 Precautions

## Servo Motor Connection Example (Rotary Servo Motor)

### Semi Closed Loop Control System with MR-J4-GF/MR-J4-B/MR-J4-A

- For HG-JR 1500 r/min series (11 kW and 15 kW)

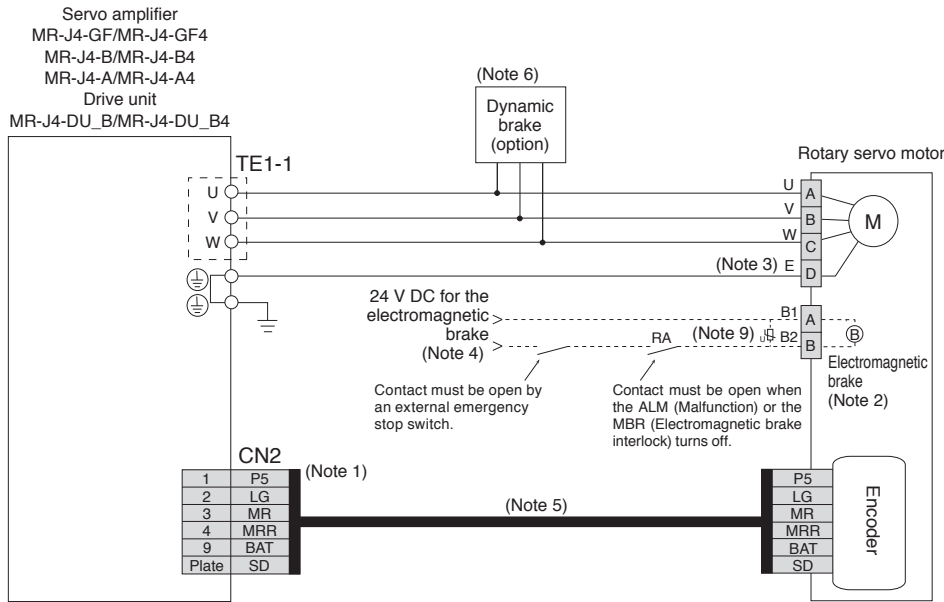

- For HG-JR 1000 r/min series (15 kW or larger) and HG-JR 1500 r/min series (22 kW or larger)

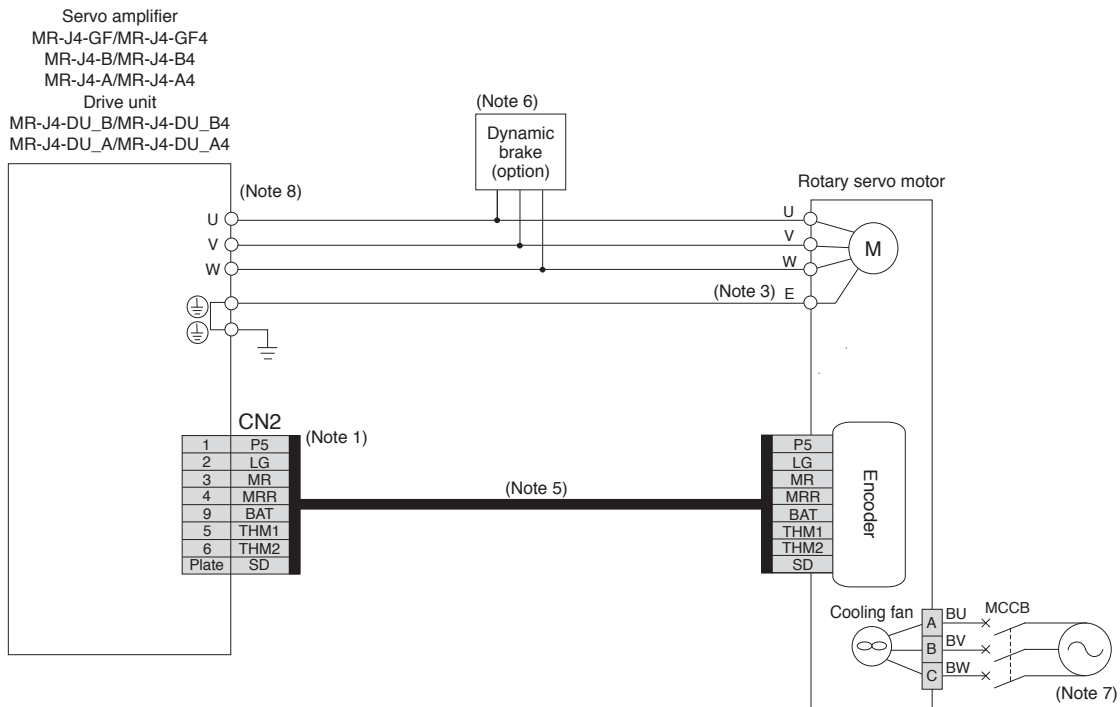

- Notes:
1. The signals shown are applicable when using a two-wire type encoder cable. Four-wire type is also compatible.
  2. This is for the servo motor with electromagnetic brake. The electromagnetic brake terminals (B1, B2) do not have polarity.
  3. Connect the grounding wire to the cabinet protective earth (PE) terminal via the servo amplifier for grounding the servo motor.
  4. Do not use the 24 V DC interface power supply for the electromagnetic brake. Provide a dedicated power supply to the electromagnetic brake.
  5. Encoder cable is available as an option. Refer to "Servo Motor Instruction Manual (Vol. 3)" when fabricating the cables.
  6. Use an external dynamic brake (option) with the servo amplifier. Without the external dynamic brake, a servo motor does not stop immediately at emergency stop and falls in free-run status, causing an accident such as machine collision, etc. Refer to relevant Servo Amplifier Instruction Manual when wiring the dynamic brake.
  7. Be sure to supply power to the cooling fan terminals. Refer to the cooling fan power supply described in the servo motor specifications in this catalog for the required power.
  8. Connector or terminal varies depending on the servo amplifier capacities. Refer to the dimensions of the relevant servo amplifier in this catalog for details.
  9. Be sure to install a surge absorber between B1 and B2.



Be sure to read through Instruction Manual for the actual wiring and use. Use the equipment after you have a full knowledge of the equipment, safety information and instructions.



## Servo Motor Connection Example (Rotary Servo Motor) Semi Closed Loop Control System with MR-J4-GF/MR-J4-B/MR-J4-A

GF B A

● For HG-RR/HG-UR series

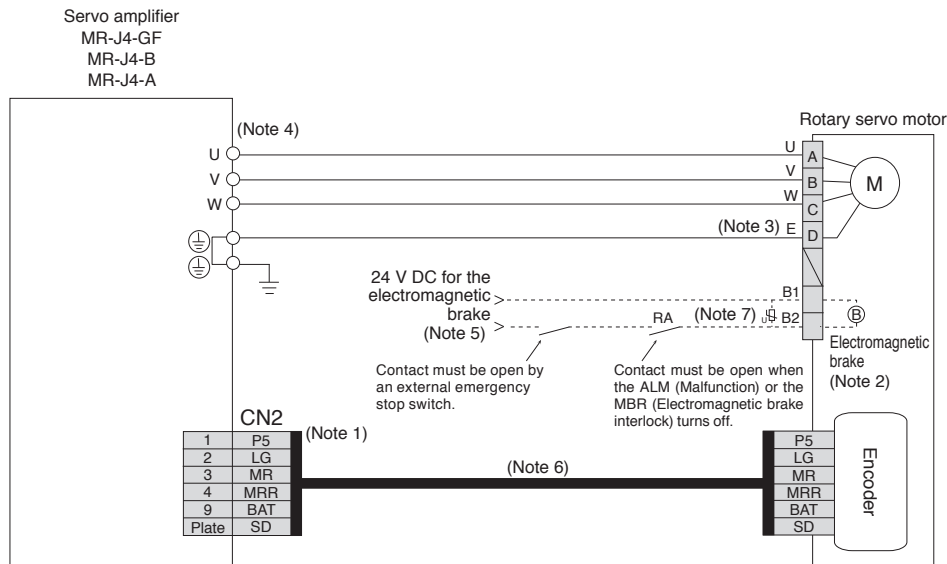

- Notes: 1. The signals shown are applicable when using a two-wire type encoder cable. Four-wire type is also compatible.  
 2. This is for the servo motor with electromagnetic brake. The electromagnetic brake terminals (B1, B2) do not have polarity. A separate connector from the motor power connector is provided as an electromagnetic brake connector for HG-UR202B to HG-UR502B. The pin numbers vary depending on the servo motor capacity. Refer to the dimensions of the relevant servo motor in this catalog for details.  
 3. Connect the grounding wire to the cabinet protective earth (PE) terminal via the servo amplifier for grounding the servo motor.  
 4. Connector or terminal varies depending on the servo amplifier capacities. Refer to the dimensions of the relevant servo amplifier in this catalog for details.  
 5. Do not use the 24 V DC interface power supply for the electromagnetic brake. Provide a dedicated power supply to the electromagnetic brake.  
 6. Encoder cable is available as an option. Refer to "Servo Motor Instruction Manual (Vol. 3)" when fabricating the cables.  
 7. Be sure to install a surge absorber between B1 and B2.

**!** Be sure to read through Instruction Manual for the actual wiring and use. Use the equipment after you have a full knowledge of the equipment, safety information and instructions.

Servo Amplifiers  
Rotary Servo Motors  
Linear Servo Motors  
Direct Drive Motors  
Options/Peripheral Equipment  
LV/S/Wires  
Product List  
Precautions

## Servo Motor Connection Example (Rotary Servo Motor)

GF B A

### Fully Closed Loop Control System with MR-J4-GF/MR-J4-B/MR-J4-A

● For HG-KR/HG-MR series

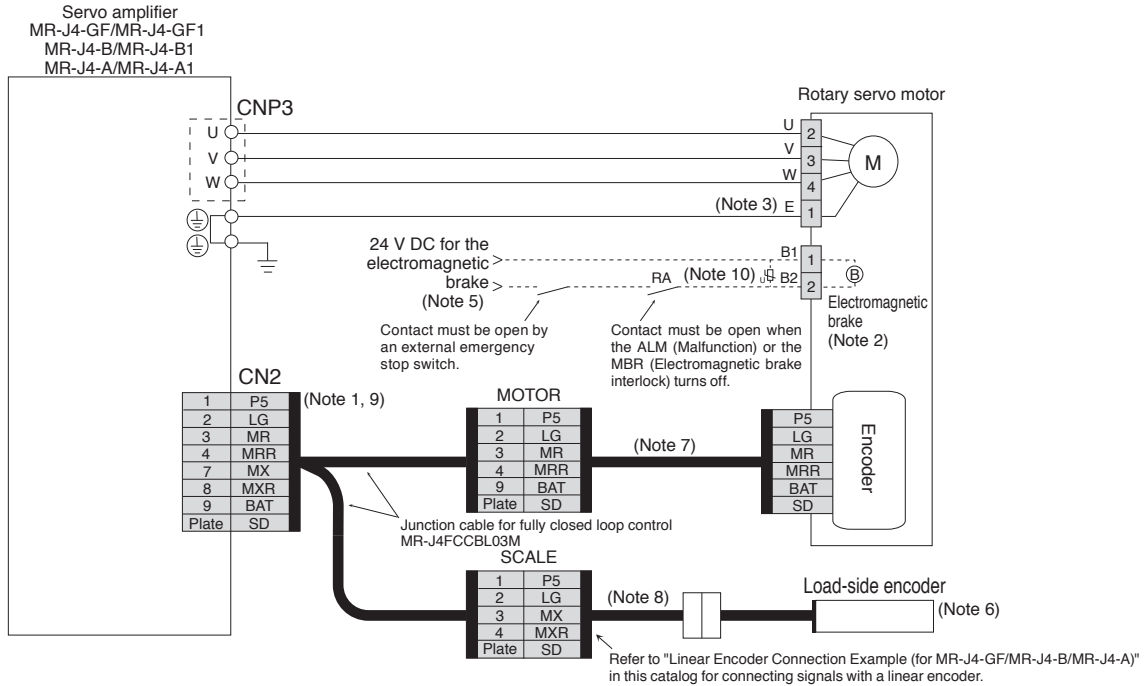

● For HG-SR/HG-JR (9 kW or smaller) series

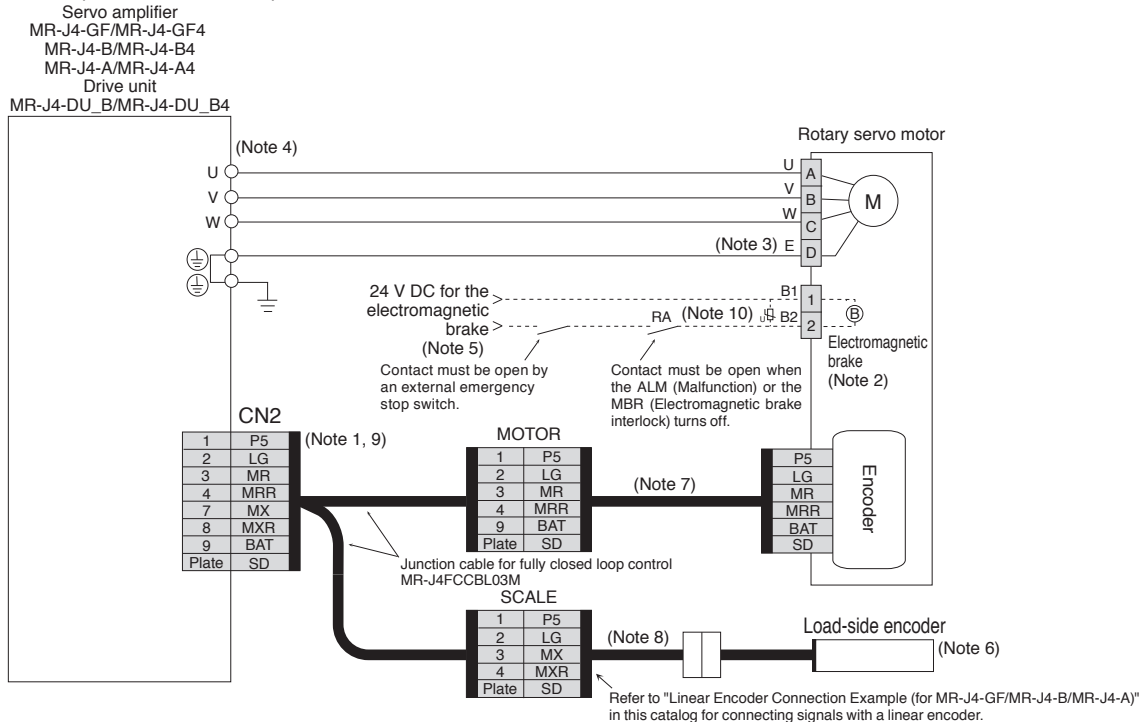

- Notes: 1. For fully closed loop control, the load-side encoder and the servo motor encoder are compatible only with two-wire type communication method. Four-wire type cannot be used.  
2. This is for the servo motor with electromagnetic brake. The electromagnetic brake terminals (B1, B2) do not have polarity.  
3. Connect the grounding wire to the cabinet protective earth (PE) terminal via the servo amplifier for grounding the servo motor.  
4. Connector or terminal varies depending on the servo amplifier capacities. Refer to the dimensions of the relevant servo amplifier in this catalog for details.  
5. Do not use the 24 V DC interface power supply for the electromagnetic brake. Provide a dedicated power supply to the electromagnetic brake.  
6. For linear encoders, refer to "List of Linear Encoders" under section 3 Linear Servo Motors in this catalog. Refer to relevant Servo Amplifier Instruction Manual for the fully closed loop control with a rotary encoder.  
7. Encoder cable is available as an option. Refer to "Servo Motor Instruction Manual (Vol. 3)" when fabricating the cables.  
8. Necessary encoder cables vary depending on the load-side encoder. Refer to relevant Instruction Manual.  
9. When configuring a fully closed loop control system with MR-J4-GF/\_MR-J4-B/\_MR-J4-DU\_B/\_MR-J4-A\_, be sure to connect MR-J4FCCBL03M junction cable or a junction cable fabricated using MR-J3THMCN2 connector set to CN2 connector.  
10. Be sure to install a surge absorber between B1 and B2.



Be sure to read through Instruction Manual for the actual wiring and use. Use the equipment after you have a full knowledge of the equipment, safety information and instructions.

**Servo Motor Connection Example (Rotary Servo Motor)**  
**Fully Closed Loop Control System with MR-J4-GF/MR-J4-B/MR-J4-A**

GF B A

● For HG-JR 1500 r/min series (11 kW and 15 kW)

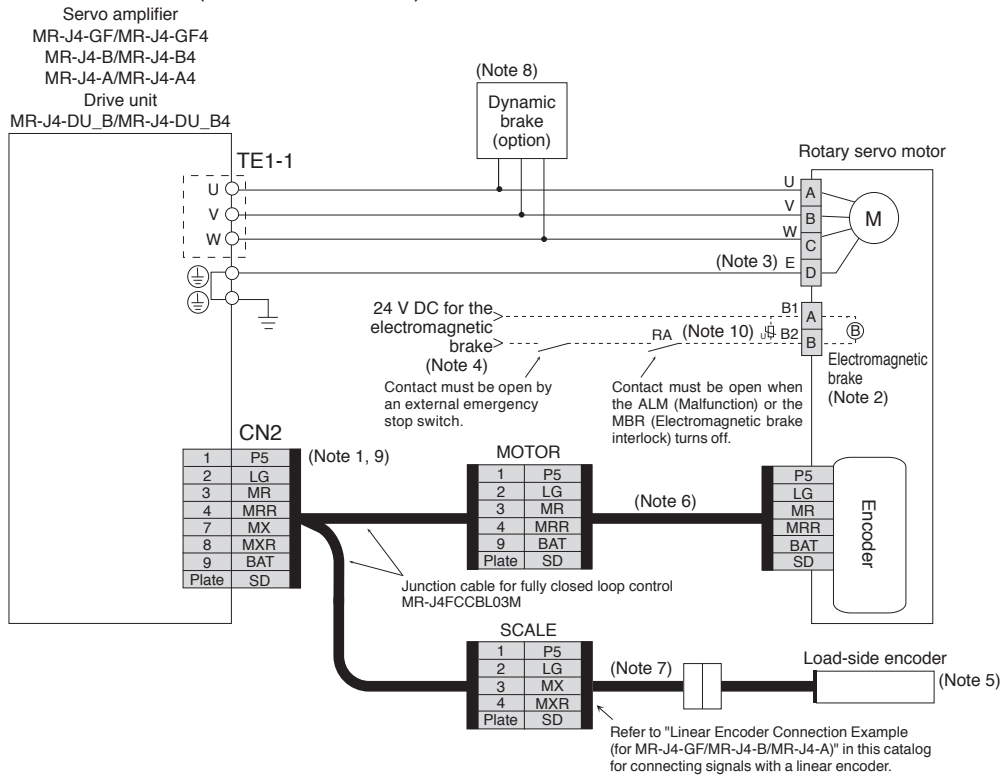

- Notes: 1. For fully closed loop control, the load-side encoder and the servo motor encoder are compatible only with two-wire type communication method. Four-wire type cannot be used.
2. This is for the servo motor with electromagnetic brake. The electromagnetic brake terminals (B1, B2) do not have polarity.
3. Connect the grounding wire to the cabinet protective earth (PE) terminal via the servo amplifier for grounding the servo motor.
4. Do not use the 24 V DC interface power supply for the electromagnetic brake. Provide a dedicated power supply to the electromagnetic brake.
5. For linear encoders, refer to "List of Linear Encoders" under section 3 Linear Servo Motors in this catalog. Refer to relevant Servo Amplifier Instruction Manual for the fully closed loop control with a rotary encoder.
6. Encoder cable is available as an option. Refer to "Servo Motor Instruction Manual (Vol. 3)" when fabricating the cables.
7. Necessary encoder cables vary depending on the load-side encoder. Refer to relevant Instruction Manual.
8. Use an external dynamic brake (option) with the servo amplifier. Without the external dynamic brake, a servo motor does not stop immediately at emergency stop and falls in free-run status, causing an accident such as machine collision, etc. Refer to relevant Servo Amplifier Instruction Manual when wiring the dynamic brake.
9. When configuring a fully closed loop control system with MR-J4-GF/\_MR-J4-B/\_MR-J4-DU\_B/\_MR-J4-A\_, be sure to connect MR-J4FCCBL03M junction cable or a junction cable fabricated using MR-J3THMCN2 connector set to CN2 connector.
10. Be sure to install a surge absorber between B1 and B2.

**!** Be sure to read through Instruction Manual for the actual wiring and use. Use the equipment after you have a full knowledge of the equipment, safety information and instructions.

Servo Amplifiers  
 Rotary Servo Motors  
 Linear Servo Motors  
 Direct Drive Motors  
 Options/Peripheral Equipment  
 LV5/Wires  
 Product List  
 Precautions

## Servo Motor Connection Example (Rotary Servo Motor)

### Fully Closed Loop Control System with MR-J4-GF/MR-J4-B/MR-J4-A

- For HG-JR 1000 r/min series (15 kW or larger) and HG-JR 1500 r/min series (22 kW or larger)

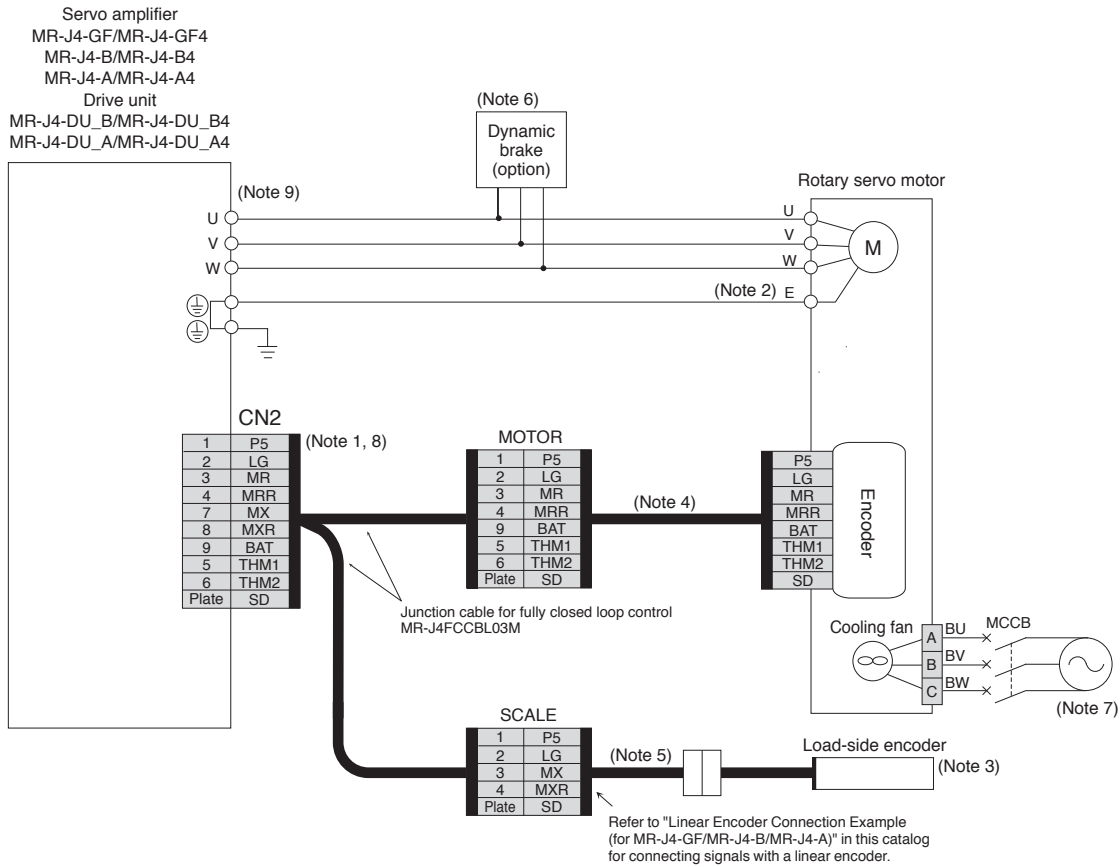

- Notes: 1. For fully closed loop control, the load-side encoder and the servo motor encoder are compatible only with two-wire type communication method. Four-wire type cannot be used.
2. Connect the grounding wire to the cabinet protective earth (PE) terminal via the servo amplifier for grounding the servo motor.
3. For linear encoders, refer to "List of Linear Encoders" under section 3 Linear Servo Motors in this catalog. Refer to relevant Servo Amplifier Instruction Manual for the fully closed loop control with a rotary encoder.
4. Encoder cable is available as an option. Refer to "Servo Motor Instruction Manual (Vol. 3)" when fabricating the cables.
5. Necessary encoder cables vary depending on the load-side encoder. Refer to relevant Instruction Manual.
6. Use an external dynamic brake (option) with the servo amplifier. Without the external dynamic brake, a servo motor does not stop immediately at emergency stop and falls in free-run status, causing an accident such as machine collision, etc. Refer to relevant Servo Amplifier Instruction Manual when wiring the dynamic brake.
7. Be sure to supply power to the cooling fan terminals. Refer to the cooling fan power supply described in the servo motor specifications in this catalog for the required power.
8. When configuring a fully closed loop control system with MR-J4-GF\_/MR-J4-B\_/MR-J4-DU\_B\_/MR-J4-A\_, be sure to connect MR-J4FCCBL03M junction cable or a junction cable fabricated using MR-J3THMCN2 connector set to CN2 connector.
9. Connector or terminal varies depending on the servo amplifier capacities. Refer to the dimensions of the relevant servo amplifier in this catalog for details.



Be sure to read through Instruction Manual for the actual wiring and use. Use the equipment after you have a full knowledge of the equipment, safety information and instructions.

**Servo Motor Connection Example (Rotary Servo Motor)**  
**Fully Closed Loop Control System with MR-J4-GF/MR-J4-B/MR-J4-A**

GF B A

● For HG-RR/HG-UR series

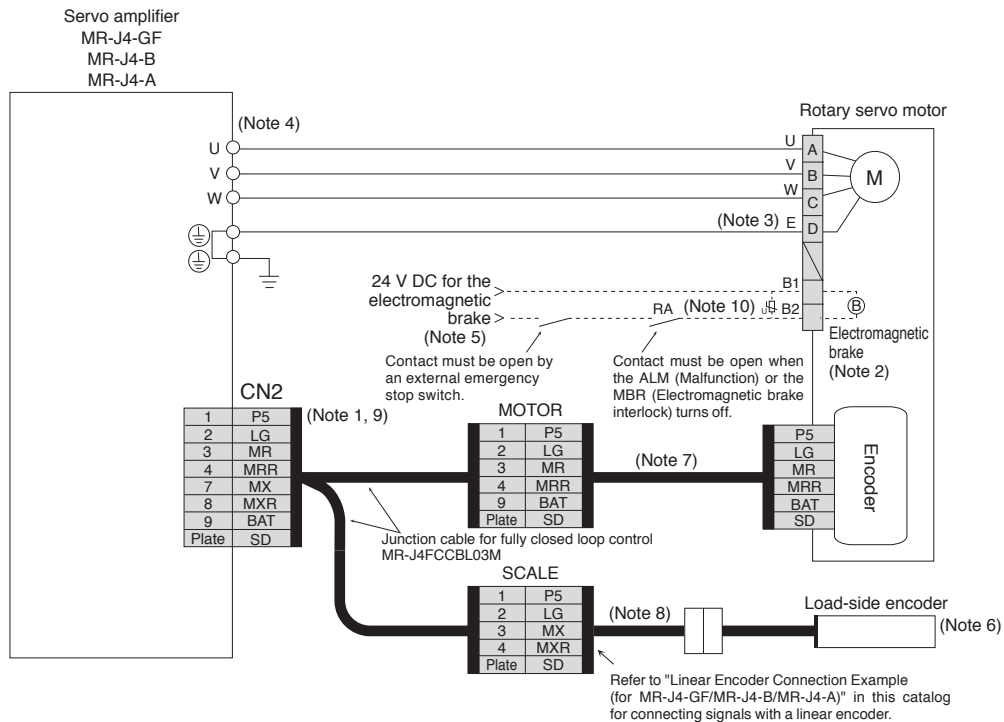

- Notes: 1. For fully closed loop control, the load-side encoder and the servo motor encoder are compatible only with two-wire type communication method. Four-wire type cannot be used.
2. This is for the servo motor with electromagnetic brake. The electromagnetic brake terminals (B1, B2) do not have polarity. A separate connector from the motor power connector is provided as an electromagnetic brake connector for HG-UR202B to HG-UR502B. The pin numbers vary depending on the servo motor capacity. Refer to the dimensions of the relevant servo motor in this catalog for details.
3. Connect the grounding wire to the cabinet protective earth (PE) terminal via the servo amplifier for grounding the servo motor.
4. Connector or terminal varies depending on the servo amplifier capacities. Refer to the dimensions of the relevant servo amplifier in this catalog for details.
5. Do not use the 24 V DC interface power supply for the electromagnetic brake. Provide a dedicated power supply to the electromagnetic brake.
6. For linear encoders, refer to "List of Linear Encoders" under section 3 Linear Servo Motors in this catalog. Refer to relevant Servo Amplifier Instruction Manual for the fully closed loop control with a rotary encoder.
7. Encoder cable is available as an option. Refer to "Servo Motor Instruction Manual (Vol. 3)" when fabricating the cables.
8. Necessary encoder cables vary depending on the load-side encoder. Refer to relevant Instruction Manual.
9. When configuring a fully closed loop control system with MR-J4-GF/MR-J4-B/MR-J4-A, be sure to connect MR-J4FCCBL03M junction cable or a junction cable fabricated using MR-J3THMCN2 connector set to CN2 connector.
10. Be sure to install a surge absorber between B1 and B2.

**!** Be sure to read through Instruction Manual for the actual wiring and use. Use the equipment after you have a full knowledge of the equipment, safety information and instructions.

Servo Amplifiers  
 Rotary Servo Motors  
 Linear Servo Motors  
 Direct Drive Motors  
 Options/Peripheral Equipment  
 LVS/Wires  
 Product List  
 Precautions

## Servo Motor Connection Example (Linear Servo Motor) Linear Servo System with MR-J4-GF/MR-J4-B/MR-J4-A

● For LM-H3/LM-F/LM-K2/LM-U2 series

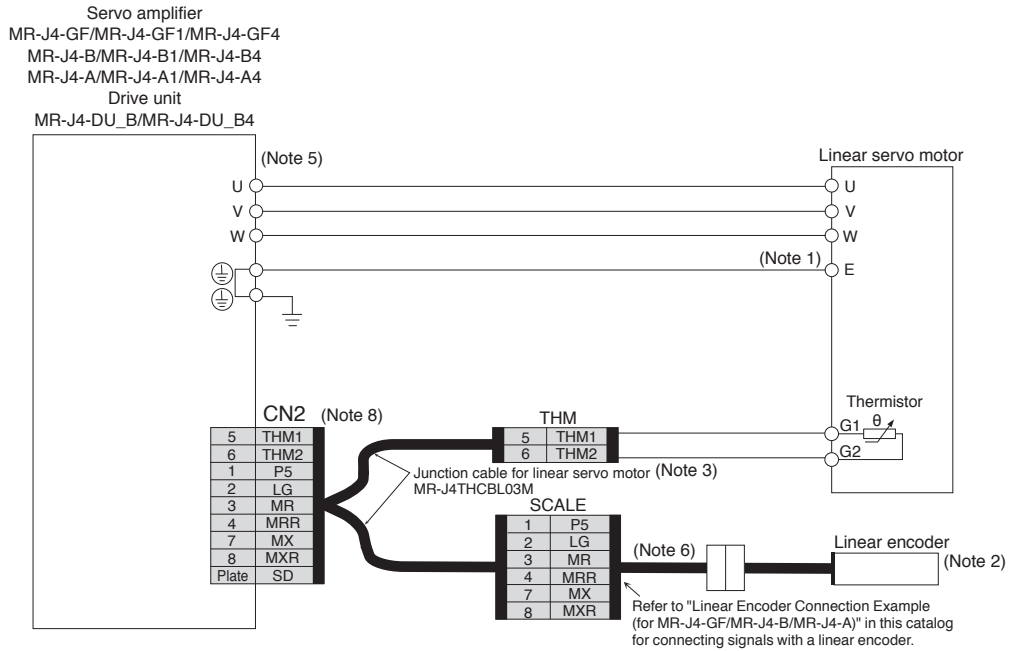

## Linear Encoder Connection Example (for MR-J4-GF/MR-J4-B/MR-J4-A)

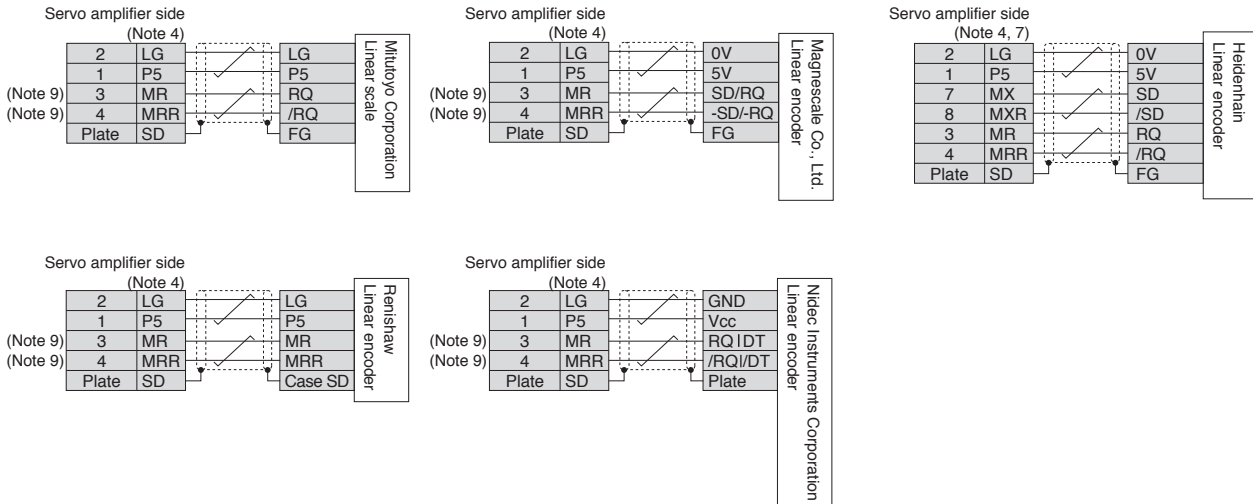

- Notes: 1. Connect the grounding wire to the cabinet protective earth (PE) terminal via the servo amplifier for grounding the servo motor.  
2. For linear encoders, refer to "List of Linear Encoders" under section 3 Linear Servo Motors in this catalog.  
3. MR-J4THCBL03M junction cable for linear servo motor is compatible with both two-wire and four-wire type linear encoders.  
4. For the number of the wire pairs for LG and P5, refer to "Linear Encoder Instruction Manual."  
5. Connector or terminal varies depending on the servo amplifier capacities. Refer to the dimensions of the relevant servo amplifier in this catalog for details.  
6. Necessary encoder cables vary depending on the linear encoder. Refer to relevant Instruction Manual.  
7. When fully closed loop control is configured with a rotary servo motor, the load-side encoder and the servo motor encoder are compatible only with two-wire type communication method. Four-wire type cannot be used.  
8. When using a linear servo motor with MR-J4-GF\_/MR-J4-B\_/MR-J4-DU\_B\_/MR-J4-A\_, be sure to connect MR-J4THCBL03M junction cable or a junction cable fabricated using MR-J3THMCN2 connector set to CN2 connector.  
9. For the fully closed loop control, MR and MRR of the servo amplifier-side connectors will be connected to MX and MXR of the SCALE connectors of MR-J4FCCL03M.



Be sure to read through Instruction Manual for the actual wiring and use. Use the equipment after you have a full knowledge of the equipment, safety information and instructions.

Servo Motor Connection Example (Direct Drive Motor)

GF GF-RJ B B-RJ A A-RJ

- For TM-RG2M/TM-RU2M/TM-RFM series (incremental system)

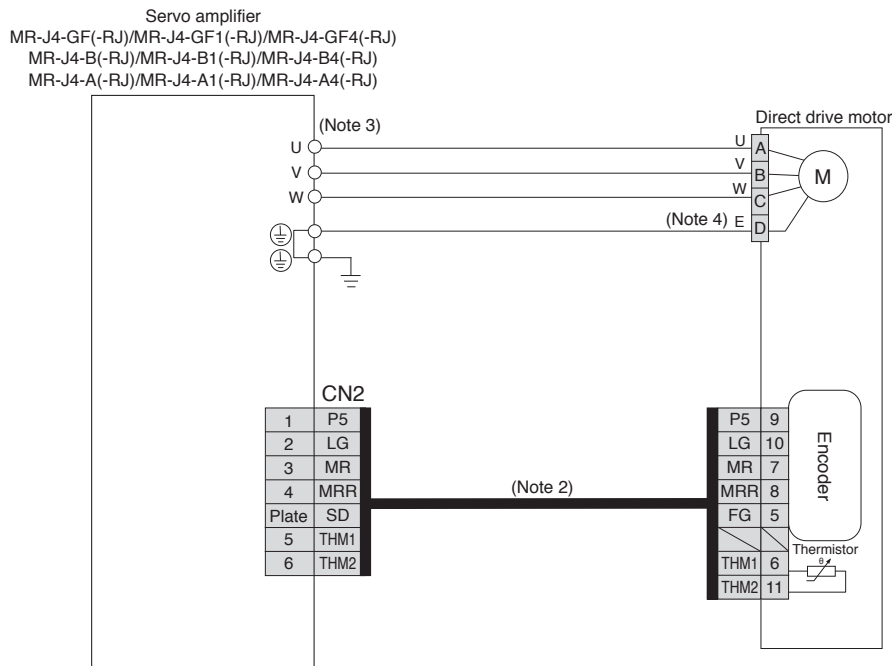

- For TM-RG2M/TM-RU2M/TM-RFM series (absolute position detection system)

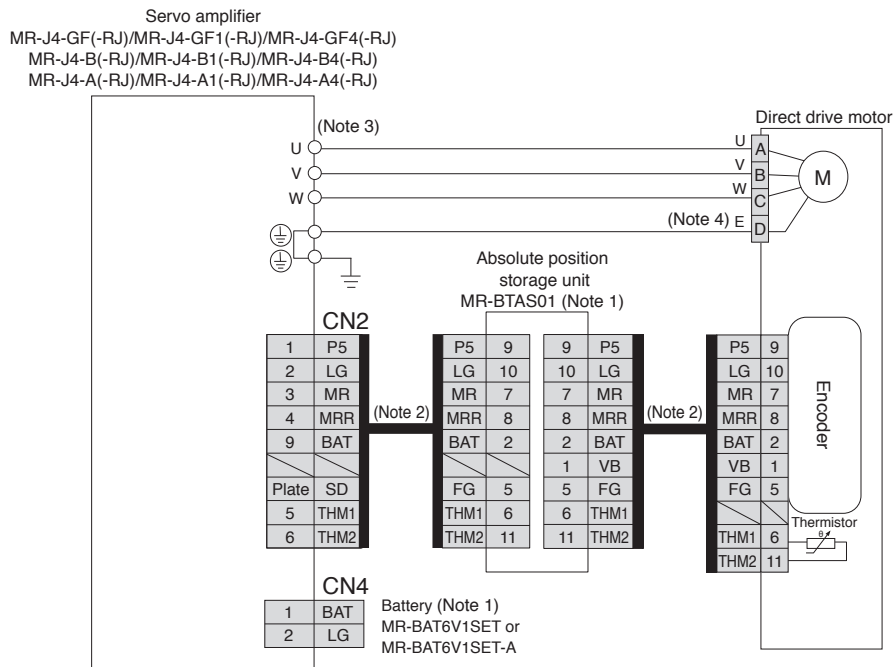

- Notes: 1. An MR-BTAS01 absolute position storage unit and MR-BAT6V1SET or MR-BAT6V1SET-A battery (sold as options) are required for absolute position detection system. Required battery varies depending on the servo amplifiers. Refer to configuration example for each servo amplifier in this catalog. Refer to relevant Servo Amplifier Instruction Manual and "TM-RFM TM-RG2M TM-RU2M Direct Drive Motor Instruction Manual" for details of absolute position detection system.
2. Fabricate this encoder cable. Refer to "TM-RFM TM-RG2M TM-RU2M Direct Drive Motor Instruction Manual" for fabricating the encoder cable.
3. Connector or terminal varies depending on the servo amplifier capacities. Refer to the dimensions of the relevant servo amplifier in this catalog for details.
4. Connect the grounding wire to the cabinet protective earth (PE) terminal via the servo amplifier for grounding the servo motor.



Be sure to read through Instruction Manual for the actual wiring and use. Use the equipment after you have a full knowledge of the equipment, safety information and instructions.

# Servo Amplifiers

## External Encoder Connection Specifications

**GF** **GF-RJ** **B** **B-RJ** **WB** **A** **A-RJ**

When configuring a linear servo system or a fully closed loop control system, or when using the scale measurement function, use the servo amplifier with the following software version.

Refer to the following table for the encoder communication method compatible with each system and for the servo amplifier connector to which a load-side encoder should be connected.

Operation mode	External encoder communication method	Connector to be connected with the external encoder							
		MR-J4-GF_	MR-J4-GF_-RJ	MR-J4-B_ / MR-J4-DU_B_	MR-J4-B_-RJ / MR-J4-DU_B_-RJ	MR-J4-A_ / MR-J4-DU_A_	MR-J4-A_-RJ / MR-J4-DU_A_-RJ	MR-J4W2-B	MR-J4W3-B
Linear servo system (Note 9)	Two-wire type	CN2 (Note 1)	CN2	CN2 (Note 1)	CN2 (Note 1)	CN2 (Note 1, 6)	CN2 (Note 1)	CN2A (Note 1) CN2B (Note 1)	CN2A (Note 1) CN2B (Note 1) CN2C (Note 1)
	Four-wire type								
	A/B/Z-phase differential output type		CN2L (Note 8)		CN2L (Note 8)		CN2L (Note 8)		
Fully closed loop control system	Two-wire type	CN2		CN2 (Note 2, 3, 5)		CN2 (Note 2, 3, 6)		CN2A (Note 2, 4, 5) CN2B (Note 2, 4, 5)	
	Four-wire type		CN2L		CN2L		CN2L		
	A/B/Z-phase differential output type								
Scale measurement function	Two-wire type	CN2		CN2 (Note 2, 3, 7)				CN2A (Note 2, 4, 7) CN2B (Note 2, 4, 7)	
	Four-wire type		CN2L		CN2L (Note 7)				
	A/B/Z-phase differential output type								

- Notes: 1. MR-J4THCBL03M junction cable is required.  
 2. MR-J4FCCBL03M junction cable is required.  
 3. MR-J4-GF\_/MR-J4-B\_/MR-DU\_B\_/MR-J4-A\_/MR-J4-DU\_A\_ is not compatible with a servo motor encoder with four-wire type communication method. Use MR-J4-GF\_-RJ/MR-J4-B\_-RJ/MR-DU\_B\_-RJ/MR-J4-A\_-RJ/MR-J4-DU\_A\_-RJ.  
 4. MR-J4W2-B servo amplifier does not support a servo motor encoder with four-wire communication method. Use MR-J4-B-RJ servo amplifier.  
 5. Supported by the servo amplifiers with software version A3 or later  
 6. Supported by the servo amplifiers with software version A5 or later  
 7. Supported by the servo amplifiers with software version A8 or later  
 8. Connect a thermistor to CN2 connector.  
 9. Refer to pp. 1-4 to 1-6 and 1-8 in this catalog for servo amplifier that is compatible with linear servo motors.



Servo Motor Connection Example (Rotary Servo Motor)

GF-RJ B-RJ A-RJ

Fully Closed Loop Control System with MR-J4-GF-RJ/MR-J4-B-RJ/MR-J4-A-RJ

● For HG-KR/HG-MR series

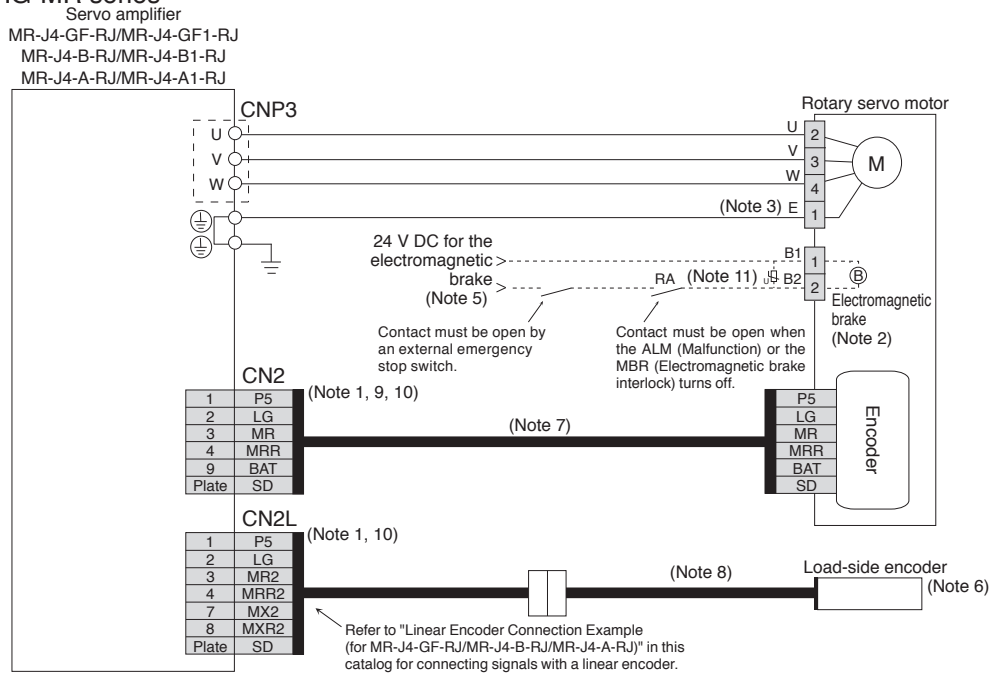

● For HG-SR/HG-JR (9 kW or smaller) series

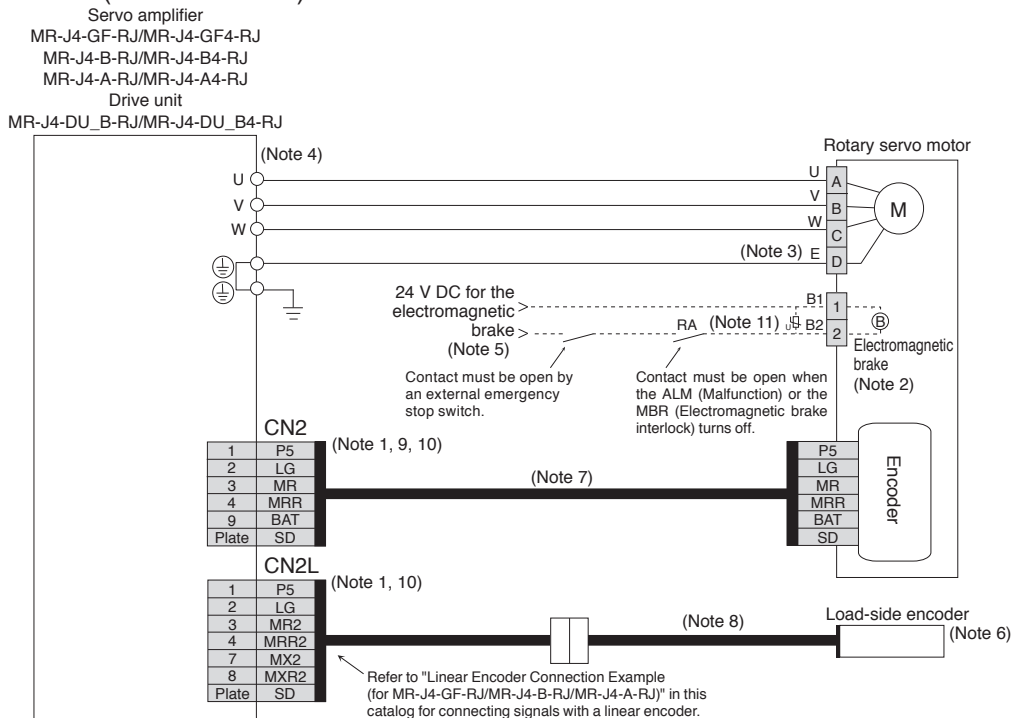

- Notes:
1. The load-side encoder and the servo motor encoder are compatible with both two-wire and four-wire type communication methods.
  2. This is for the servo motor with electromagnetic brake. The electromagnetic brake terminals (B1, B2) do not have polarity.
  3. Connect the grounding wire to the cabinet protective earth (PE) terminal via the servo amplifier for grounding the servo motor.
  4. Connector or terminal varies depending on the servo amplifier capacities. Refer to the dimensions of the relevant servo amplifier in this catalog for details.
  5. Do not use the 24 V DC interface power supply for the electromagnetic brake. Provide a dedicated power supply to the electromagnetic brake.
  6. For linear encoders, refer to "List of Linear Encoders" under section 3 Linear Servo Motors in this catalog. Refer to relevant Servo Amplifier Instruction Manual for the fully closed loop control with a rotary encoder.
  7. Encoder cable is available as an option. Refer to "Servo Motor Instruction Manual (Vol. 3)" when fabricating the cables.
  8. Necessary encoder cables vary depending on the load-side encoder. Refer to relevant Instruction Manual.
  9. This wiring of the servo motor encoder is applicable for the two-wire type communication method.
  10. When configuring a fully closed loop control system with MR-J4-GF-RJ/MR-J4-B-RJ/MR-J4-DU\_B-RJ/MR-J4-A-RJ, be sure to connect a servo motor encoder to CN2 connector and a load-side encoder to CN2L connector. Do not use MR-J4FCCBL03M junction cable or a junction cable fabricated using MR-J3THMCN2 connector set.
  11. Be sure to install a surge absorber between B1 and B2.



Be sure to read through Instruction Manual for the actual wiring and use. Use the equipment after you have a full knowledge of the equipment, safety information and instructions.

## Servo Motor Connection Example (Rotary Servo Motor)

GF-RJ B-RJ A-RJ

### Fully Closed Loop Control System with MR-J4-GF-RJ/MR-J4-B-RJ/MR-J4-A-RJ

● For HG-JR 1500 r/min series (11 kW and 15 kW)

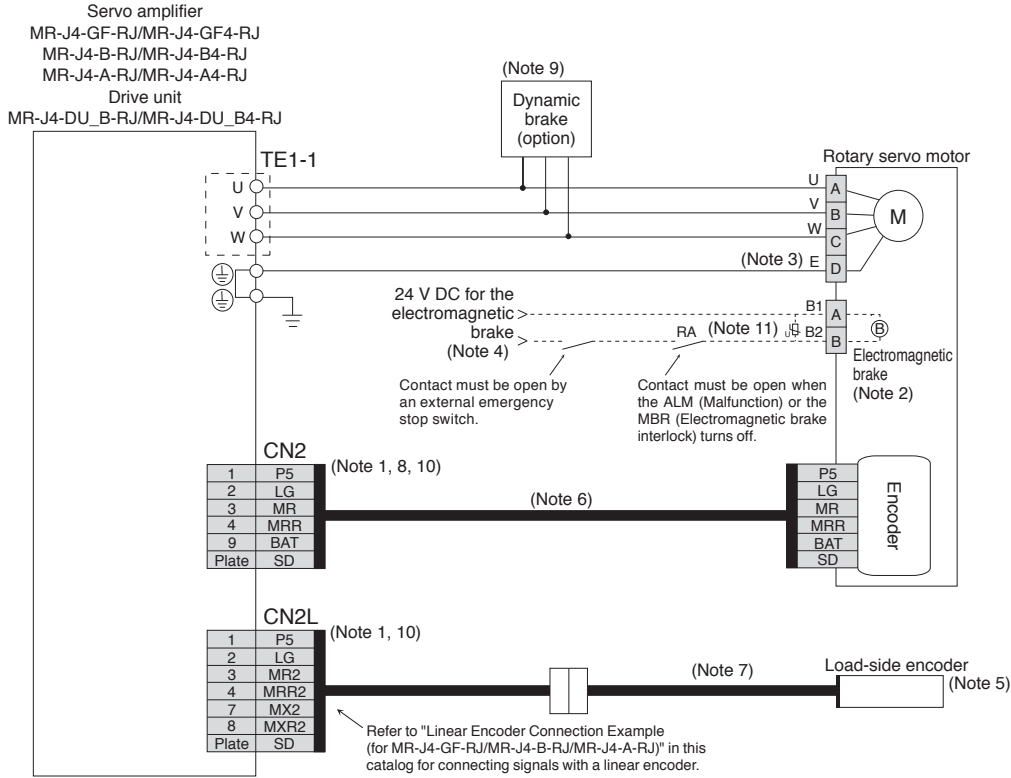

- Notes:
1. The load-side encoder and the servo motor encoder are compatible with both two-wire and four-wire type communication methods.
  2. This is for the servo motor with electromagnetic brake. The electromagnetic brake terminals (B1, B2) do not have polarity.
  3. Connect the grounding wire to the cabinet protective earth (PE) terminal via the servo amplifier for grounding the servo motor.
  4. Do not use the 24 V DC interface power supply for the electromagnetic brake. Provide a dedicated power supply to the electromagnetic brake.
  5. For linear encoders, refer to "List of Linear Encoders" under section 3 Linear Servo Motors in this catalog. Refer to relevant Servo Amplifier Instruction Manual for the fully closed loop control with a rotary encoder.
  6. Encoder cable is available as an option. Refer to "Servo Motor Instruction Manual (Vol. 3)" when fabricating the cables.
  7. Necessary encoder cables vary depending on the load-side encoder. Refer to relevant Instruction Manual.
  8. This wiring of the servo motor encoder is applicable for the two-wire type communication method.
  9. Use an external dynamic brake (option) with the servo amplifier. Without the external dynamic brake, a servo motor does not stop immediately at emergency stop and falls in free-run status, causing an accident such as machine collision, etc. Refer to relevant Servo Amplifier Instruction Manual when wiring the dynamic brake.
  10. When configuring a fully closed loop control system with MR-J4-GF-RJ/MR-J4-B-RJ/MR-J4-DU\_B-RJ/MR-J4-A-RJ, be sure to connect a servo motor encoder to CN2 connector and a load-side encoder to CN2L connector. Do not use MR-J4FCCBL03M junction cable or a junction cable fabricated using MR-J3THMCN2 connector set.
  11. Be sure to install a surge absorber between B1 and B2.



Be sure to read through Instruction Manual for the actual wiring and use. Use the equipment after you have a full knowledge of the equipment, safety information and instructions.

Servo Motor Connection Example (Rotary Servo Motor)

GF-RJ B-RJ A-RJ

Fully Closed Loop Control System with MR-J4-GF-RJ/MR-J4-B-RJ/MR-J4-A-RJ

● For HG-JR 1000 r/min series (15 kW or larger) and HG-JR 1500 r/min series (22 kW or larger)

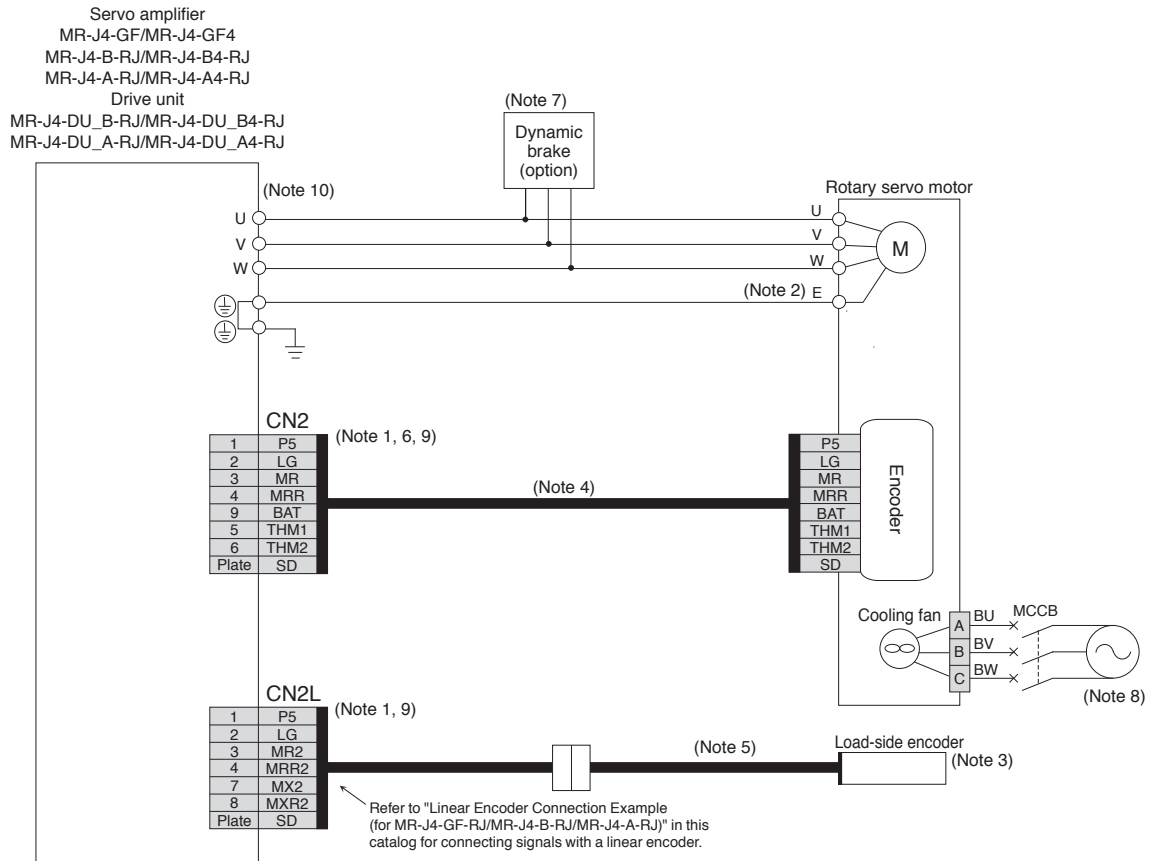

- Notes: 1. The load-side encoder and the servo motor encoder are compatible with both two-wire and four-wire type communication methods.  
 2. Connect the grounding wire to the cabinet protective earth (PE) terminal via the servo amplifier for grounding the servo motor.  
 3. For linear encoders, refer to "List of Linear Encoders" under section 3 Linear Servo Motors in this catalog. Refer to relevant Servo Amplifier Instruction Manual for the fully closed loop control with a rotary encoder.  
 4. Encoder cable is available as an option. Refer to "Servo Motor Instruction Manual (Vol. 3)" when fabricating the cables.  
 5. Necessary encoder cables vary depending on the load-side encoder. Refer to relevant Instruction Manual.  
 6. This wiring of the servo motor encoder is applicable for the two-wire type communication method.  
 7. Use an external dynamic brake (option) with the servo amplifier. Without the external dynamic brake, a servo motor does not stop immediately at emergency stop and falls in free-run status, causing an accident such as machine collision, etc. Refer to relevant Servo Amplifier Instruction Manual when wiring the dynamic brake.  
 8. Be sure to supply power to the cooling fan terminals. Refer to the cooling fan power supply described in the servo motor specifications in this catalog for the required power.  
 9. When configuring a fully closed loop control system with MR-J4-GF-RJ/MR-J4-B-RJ/MR-J4-DU\_B-RJ/MR-J4-A-RJ, be sure to connect a servo motor encoder to CN2 connector and a load-side encoder to CN2L connector. Do not use MR-J4FCCBL03M junction cable or a junction cable fabricated using MR-J3THMCN2 connector set.  
 10. Connector or terminal varies depending on the servo amplifier capacities. Refer to the dimensions of the relevant servo amplifier in this catalog for details.

**!** Be sure to read through Instruction Manual for the actual wiring and use. Use the equipment after you have a full knowledge of the equipment, safety information and instructions.

Servo Amplifiers

Rotary Servo Motors

Linear Servo Motors

Direct Drive Motors

Options/Peripheral Equipment

LVS/Wires

Product List

Precautions

## Servo Motor Connection Example (Rotary Servo Motor)

GF-RJ B-RJ A-RJ

### Fully Closed Loop Control System with MR-J4-GF-RJ/MR-J4-B-RJ/MR-J4-A-RJ

● For HG-RR/HG-UR series

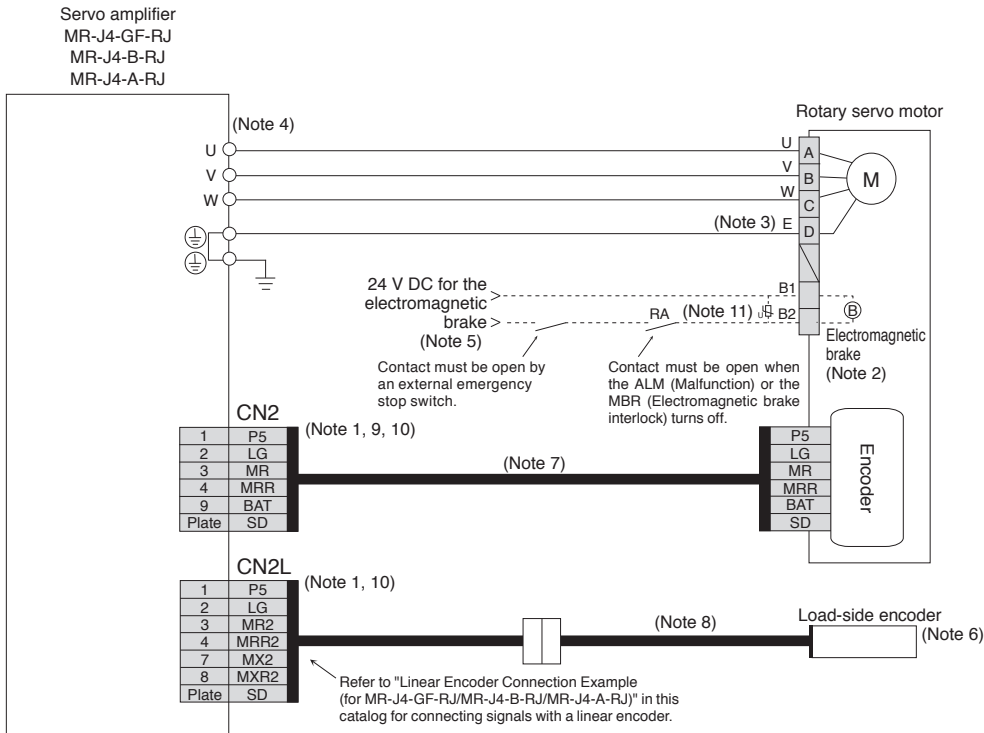

- Notes:
1. The load-side encoder and the servo motor encoder are compatible with both two-wire and four-wire type communication methods.
  2. This is for the servo motor with electromagnetic brake. The electromagnetic brake terminals (B1, B2) do not have polarity. A separate connector from the motor power connector is provided as an electromagnetic brake connector for HG-UR202B to HG-UR502B. The pin numbers vary depending on the servo motor capacity. Refer to the dimensions of the relevant servo motor in this catalog for details.
  3. Connect the grounding wire to the cabinet protective earth (PE) terminal via the servo amplifier for grounding the servo motor.
  4. Connector or terminal varies depending on the servo amplifier capacities. Refer to the dimensions of the relevant servo amplifier in this catalog for details.
  5. Do not use the 24 V DC interface power supply for the electromagnetic brake. Provide a dedicated power supply to the electromagnetic brake.
  6. For linear encoders, refer to "List of Linear Encoders" under section 3 Linear Servo Motors in this catalog. Refer to relevant Servo Amplifier Instruction Manual for the fully closed loop control with a rotary encoder.
  7. Encoder cable is available as an option. Refer to "Servo Motor Instruction Manual (Vol. 3)" when fabricating the cables.
  8. Necessary encoder cables vary depending on the load-side encoder. Refer to relevant Instruction Manual.
  9. This wiring of the servo motor encoder is applicable for the two-wire type communication method.
  10. When configuring a fully closed loop control system with MR-J4-GF-RJ/MR-J4-B-RJ/MR-J4-A-RJ, be sure to connect a servo motor encoder to CN2 connector and a load-side encoder to CN2L connector. Do not use MR-J4FCCBL03M junction cable or a junction cable fabricated using MR-J3THMCN2 connector set.
  11. Be sure to install a surge absorber between B1 and B2.



Be sure to read through Instruction Manual for the actual wiring and use. Use the equipment after you have a full knowledge of the equipment, safety information and instructions.

Servo Motor Connection Example (Linear Servo Motor)

GF-RJ B-RJ A-RJ

Linear Servo System with MR-J4-GF-RJ/MR-J4-B-RJ/MR-J4-A-RJ (LM-H3, LM-F, LM-K2, LM-U2)

●Connecting a serial linear encoder

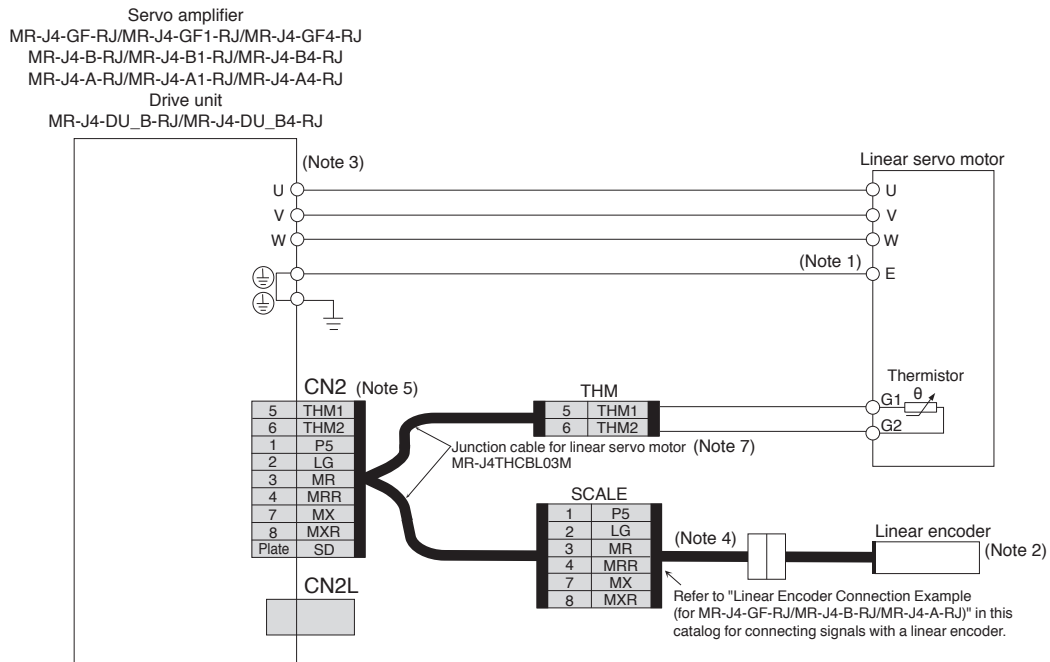

●Connecting an A/B/Z-phase differential output linear encoder

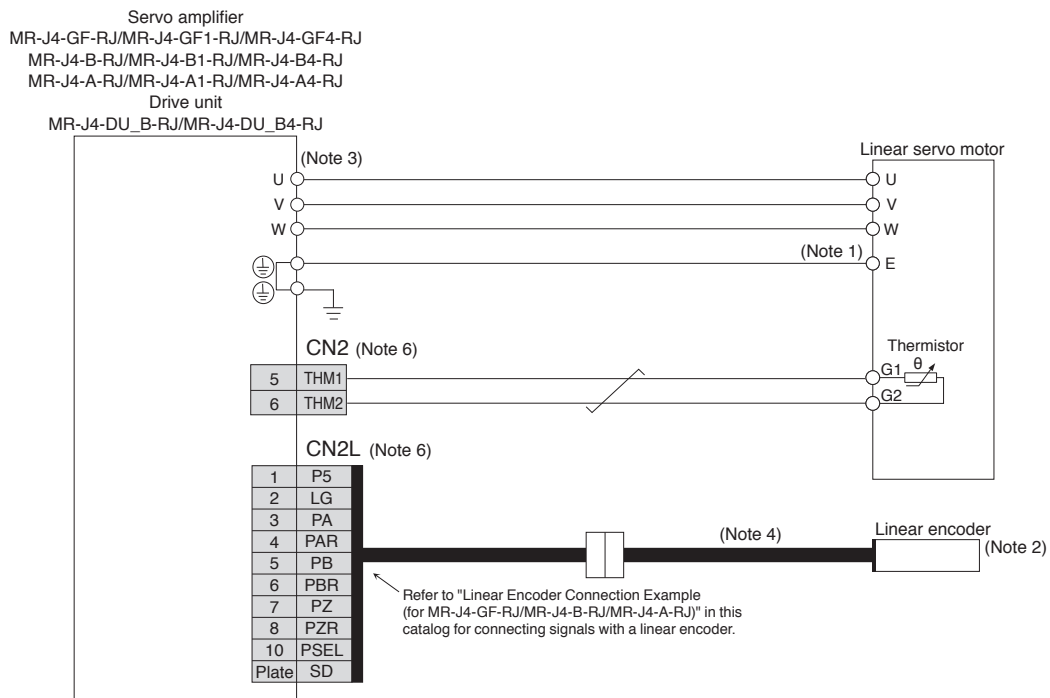

- Notes: 1. Connect the grounding wire to the cabinet protective earth (PE) terminal via the servo amplifier for grounding the servo motor.  
2. For linear encoders, refer to "List of Linear Encoders" under section 3 Linear Servo Motors in this catalog.  
3. Connector or terminal varies depending on the servo amplifier capacities. Refer to the dimensions of the relevant servo amplifier in this catalog for details.  
4. Necessary encoder cables vary depending on the linear encoder. Refer to relevant Instruction Manual.  
5. When configuring a linear servo system with MR-J4-GF-RJ/MR-J4-B-RJ/MR-J4-DU\_B-RJ/MR-J4-A-RJ and a serial linear encoder, be sure to connect MR-J4THCBL03M junction cable or a junction cable fabricated using MR-J3THMCN2 connector set to CN2 connector.  
6. When configuring a linear servo system with MR-J4-GF-RJ/MR-J4-B-RJ/MR-J4-DU\_B-RJ/MR-J4-A-RJ and an A/B/Z-phase differential output type linear encoder, be sure to connect a thermistor to CN2 connector and the linear encoder to CN2L connector. Do not use MR-J4THCBL03M junction cable or a junction cable fabricated using MR-J3THMCN2 connector set.  
7. MR-J4THCBL03M junction cable for linear servo motor is compatible with both two-wire and four-wire type linear encoders.



Be sure to read through Instruction Manual for the actual wiring and use. Use the equipment after you have a full knowledge of the equipment, safety information and instructions.

# Servo Amplifiers

## Linear Encoder Connection Example (for MR-J4-GF-RJ/MR-J4-B-RJ/MR-J4-A-RJ) **GF-RJ** **B-RJ** **A-RJ**

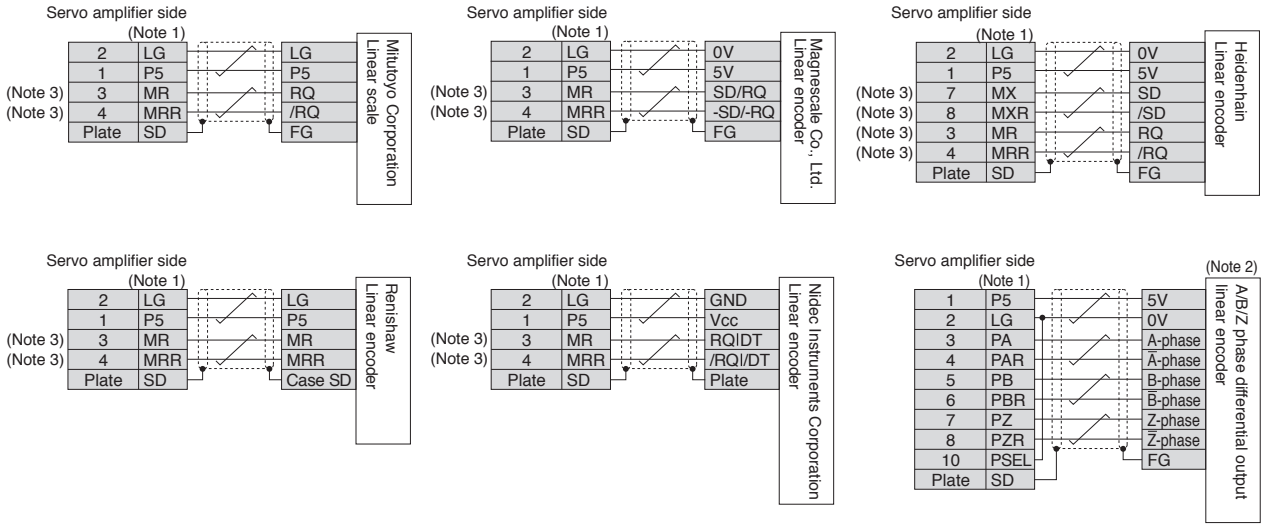

- Notes: 1. For the number of the wire pairs for LG and P5, refer to "Linear Encoder Instruction Manual."  
 2. If the encoder's current consumption exceeds 350 mA, supply power from an external source.  
 3. For the fully closed loop control, the signals of 3-pin, 4-pin, 7-pin, and 8-pin of the CN2L connector are as follows:  
 3-pin: MR2  
 4-pin: MRR2  
 7-pin: MX2  
 8-pin: MXR2



Be sure to read through Instruction Manual for the actual wiring and use. Use the equipment after you have a full knowledge of the equipment, safety information and instructions.

MR-J4-GF/MR-J4-GF-RJ Dimensions

- MR-J4-10GF, MR-J4-10GF-RJ, MR-J4-10GF1, MR-J4-10GF1-RJ
- MR-J4-20GF, MR-J4-20GF-RJ, MR-J4-20GF1, MR-J4-20GF1-RJ
- MR-J4-40GF, MR-J4-40GF-RJ, MR-J4-40GF1, MR-J4-40GF1-RJ
- MR-J4-60GF, MR-J4-60GF-RJ

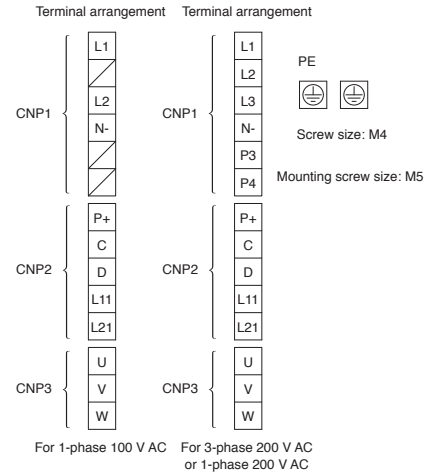
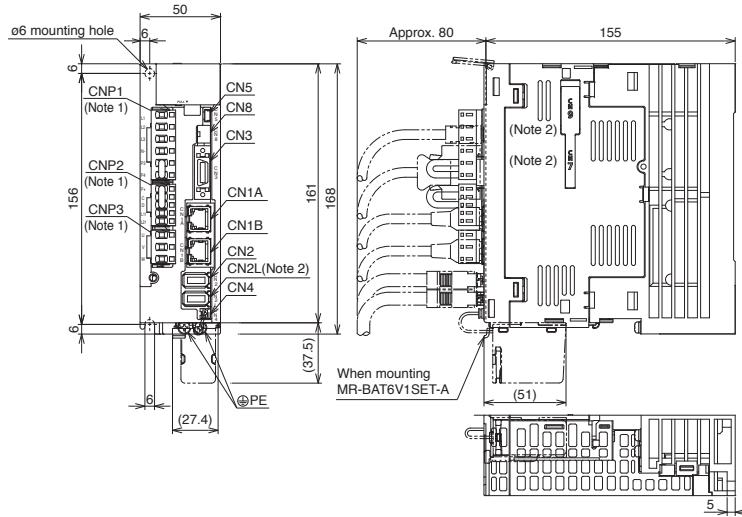

[Unit: mm]

- MR-J4-70GF, MR-J4-70GF-RJ
- MR-J4-100GF, MR-J4-100GF-RJ

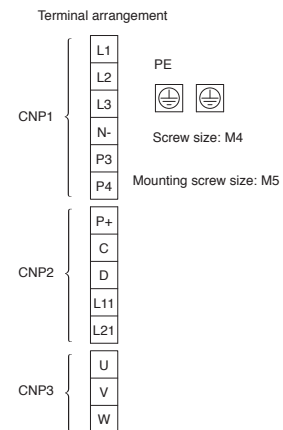
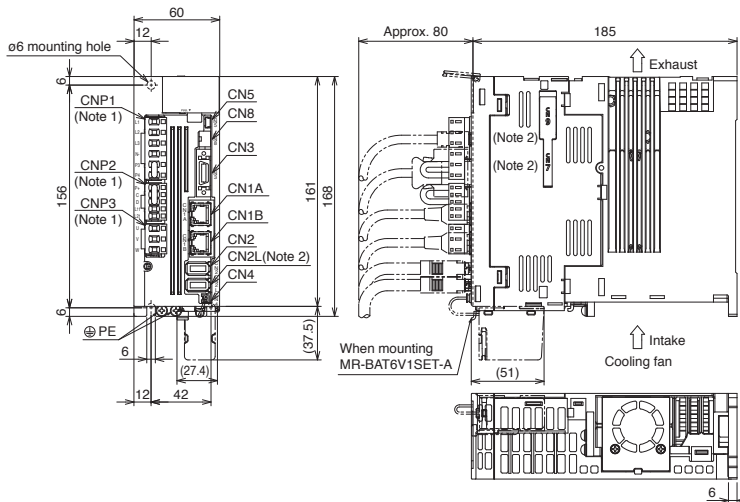

[Unit: mm]

Notes: 1. CNP1, CNP2 and CNP3 connectors are supplied with the servo amplifier.  
2. CN2L, CN7, and CN9 connectors are not available for MR-J4-GF servo amplifier.

# Servo Amplifiers

## MR-J4-GF/MR-J4-GF-RJ Dimensions

**GF GF-RJ**

- MR-J4-60GF4, MR-J4-60GF4-RJ
- MR-J4-100GF4, MR-J4-100GF4-RJ

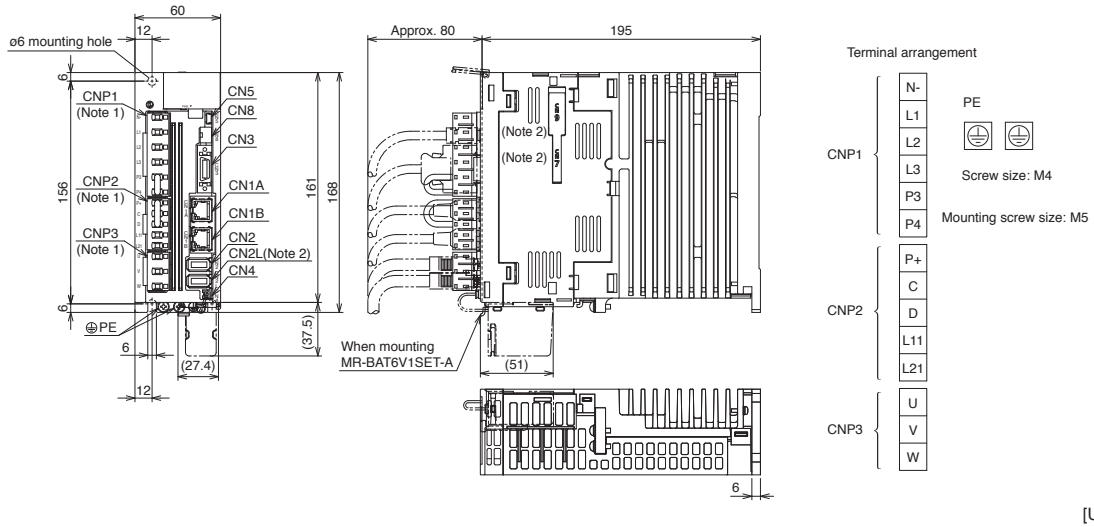

[Unit: mm]

- MR-J4-200GF, MR-J4-200GF-RJ

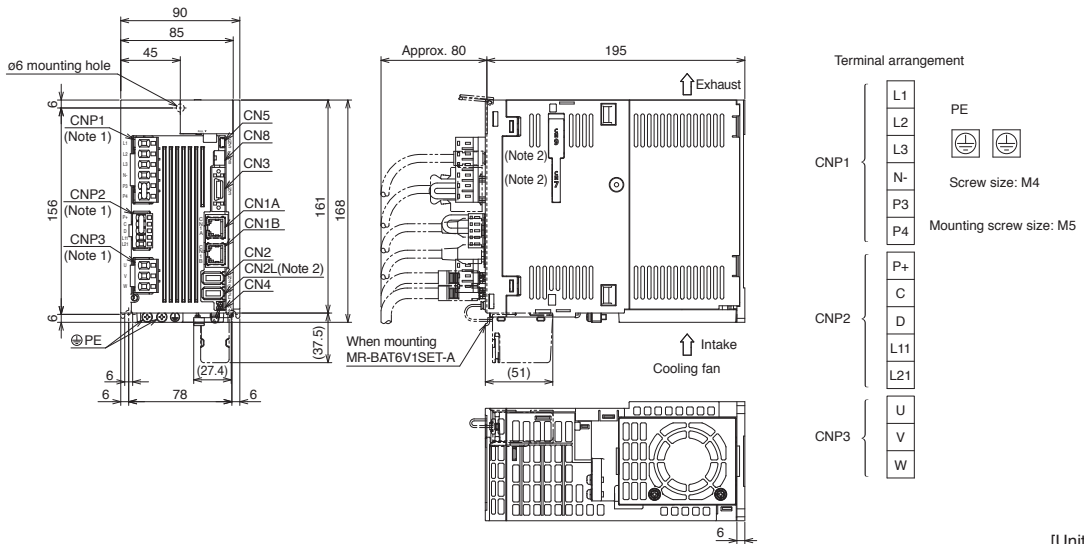

[Unit: mm]

- MR-J4-200GF4, MR-J4-200GF4-RJ

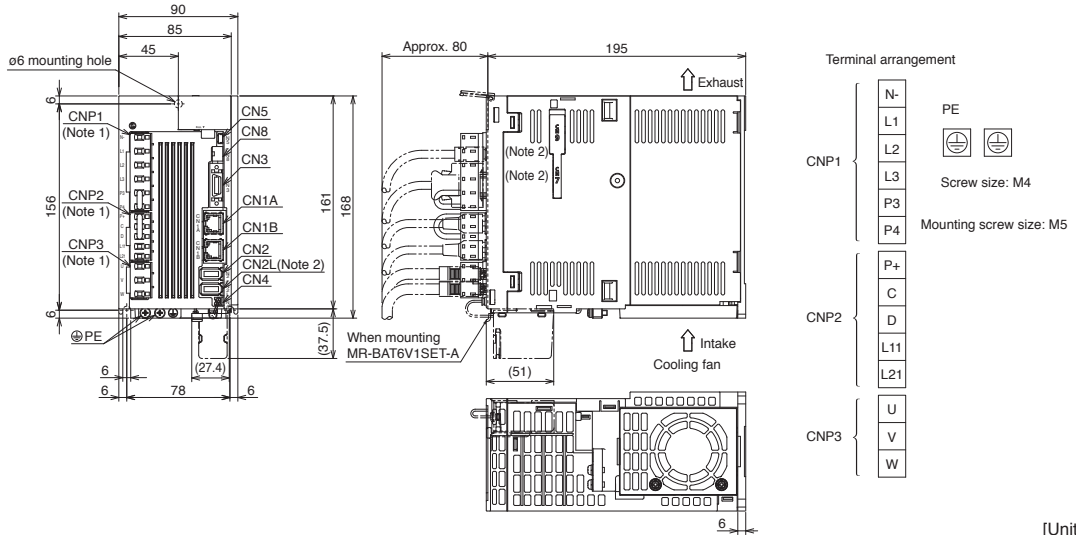

[Unit: mm]

Notes: 1. CNP1, CNP2 and CNP3 connectors are supplied with the servo amplifier.  
 2. CN2L, CN7, and CN9 connectors are not available for MR-J4-GF servo amplifier.



MR-J4-GF/MR-J4-GF-RJ Dimensions

●MR-J4-350GF, MR-J4-350GF-RJ

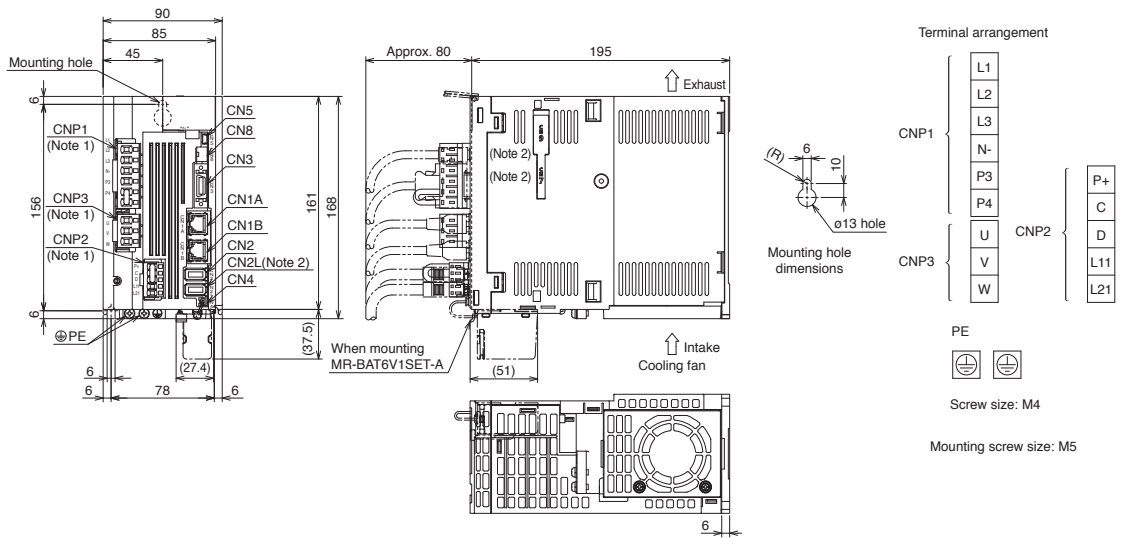

[Unit: mm]

●MR-J4-350GF4, MR-J4-350GF4-RJ

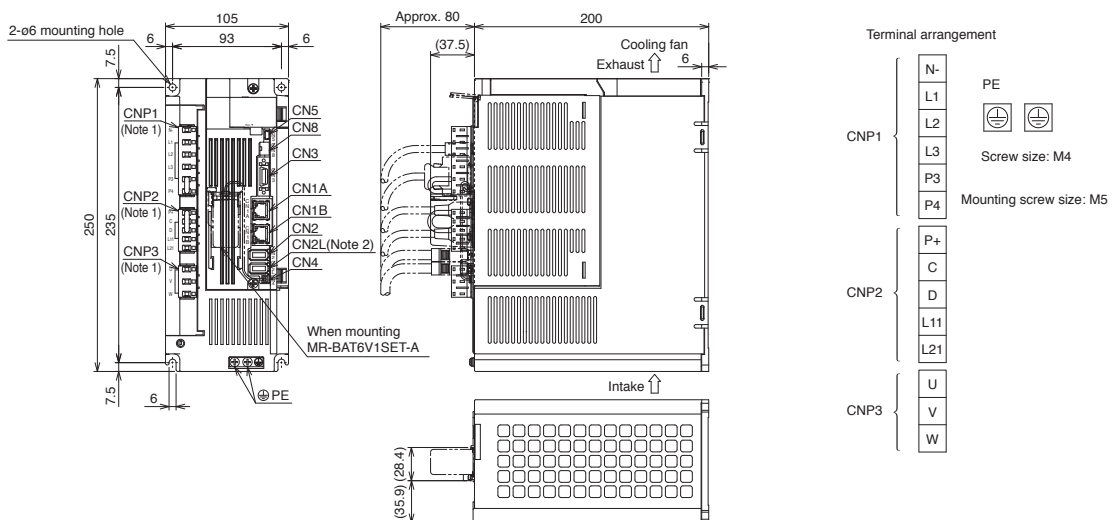

[Unit: mm]

●MR-J4-500GF, MR-J4-500GF-RJ

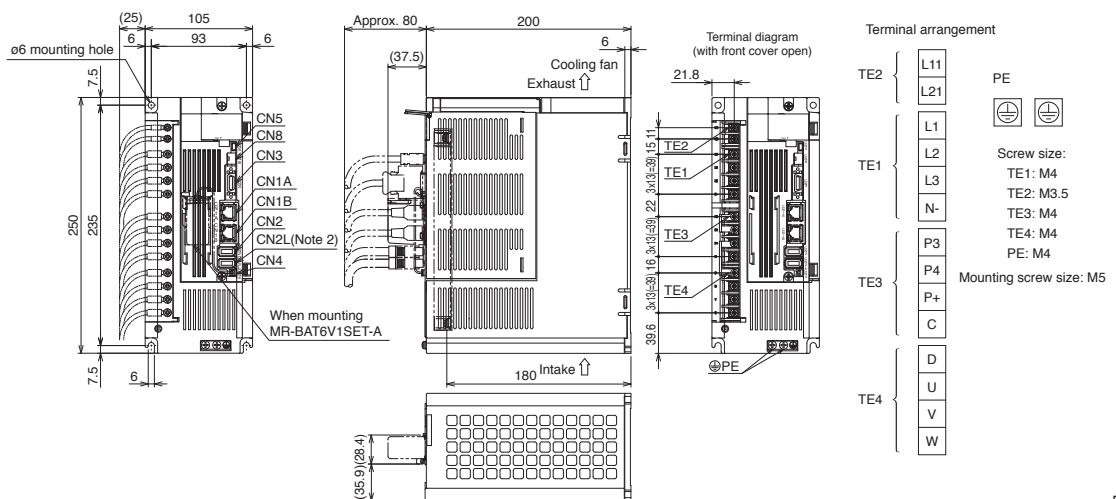

[Unit: mm]

Notes: 1. CNP1, CNP2 and CNP3 connectors are supplied with the servo amplifier.  
2. CN2L, CN7, and CN9 connectors are not available for MR-J4-GF servo amplifier.

# Servo Amplifiers

## MR-J4-GF/MR-J4-GF-RJ Dimensions

GF GF-RJ

### ●MR-J4-500GF4, MR-J4-500GF4-RJ

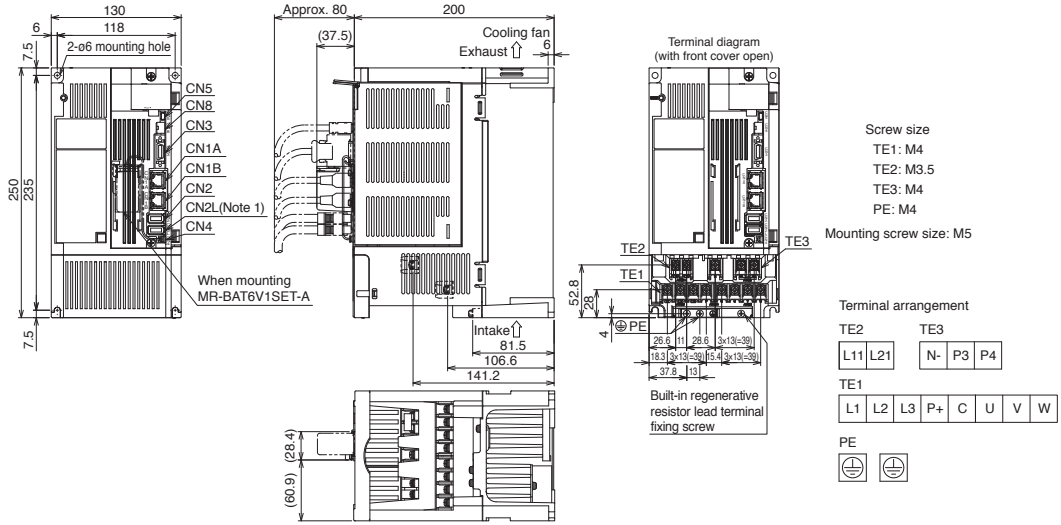

[Unit: mm]

### ●MR-J4-700GF, MR-J4-700GF-RJ

### ●MR-J4-700GF4, MR-J4-700GF4-RJ

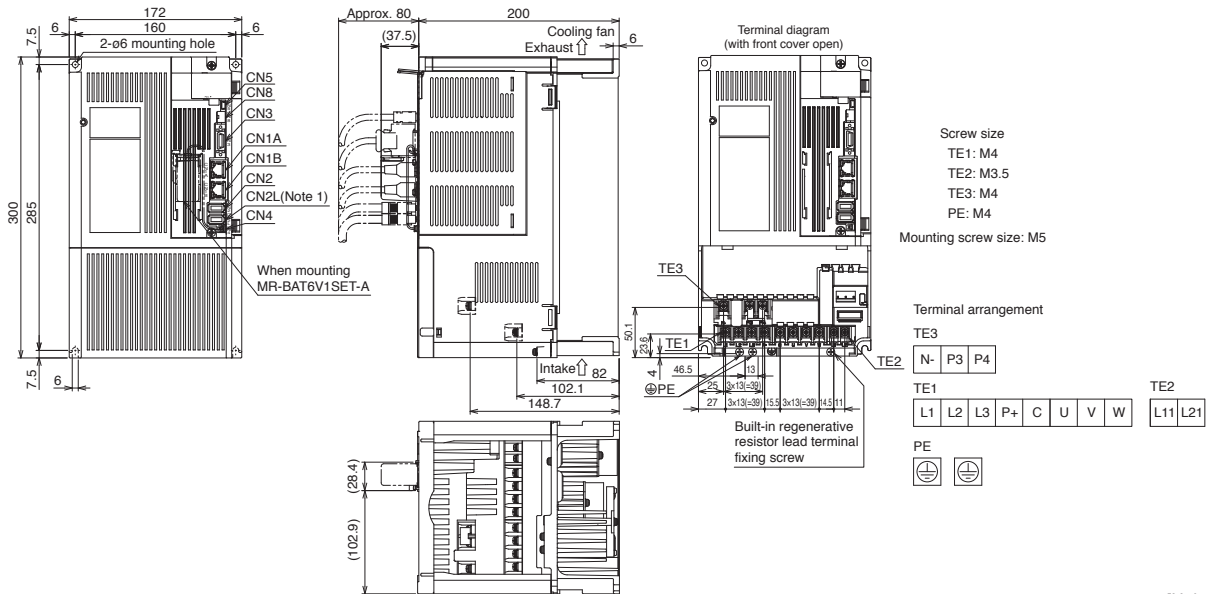

[Unit: mm]

Notes: 1. CN2L, CN7, and CN9 connectors are not available for MR-J4-GF servo amplifier.

MR-J4-GF/MR-J4-GF-RJ Dimensions

- MR-J4-11KGF, MR-J4-11KGF-RJ, MR-J4-11KGF4, MR-J4-11KGF4-RJ
- MR-J4-15KGF, MR-J4-15KGF-RJ, MR-J4-15KGF4, MR-J4-15KGF4-RJ

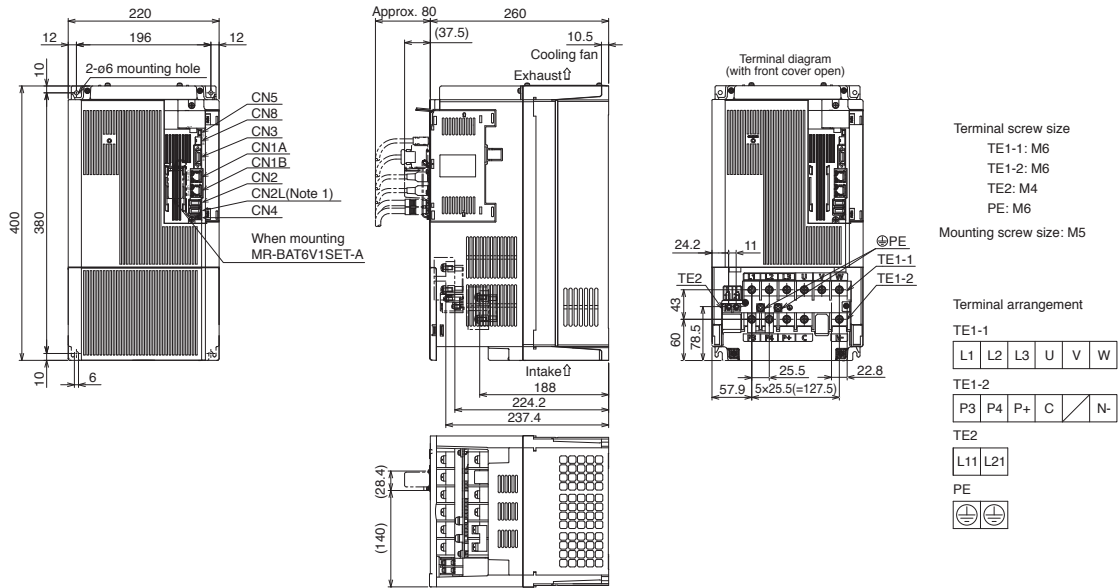

[Unit: mm]

- MR-J4-22KGF, MR-J4-22KGF-RJ, MR-J4-22KGF4, MR-J4-22KGF4-RJ

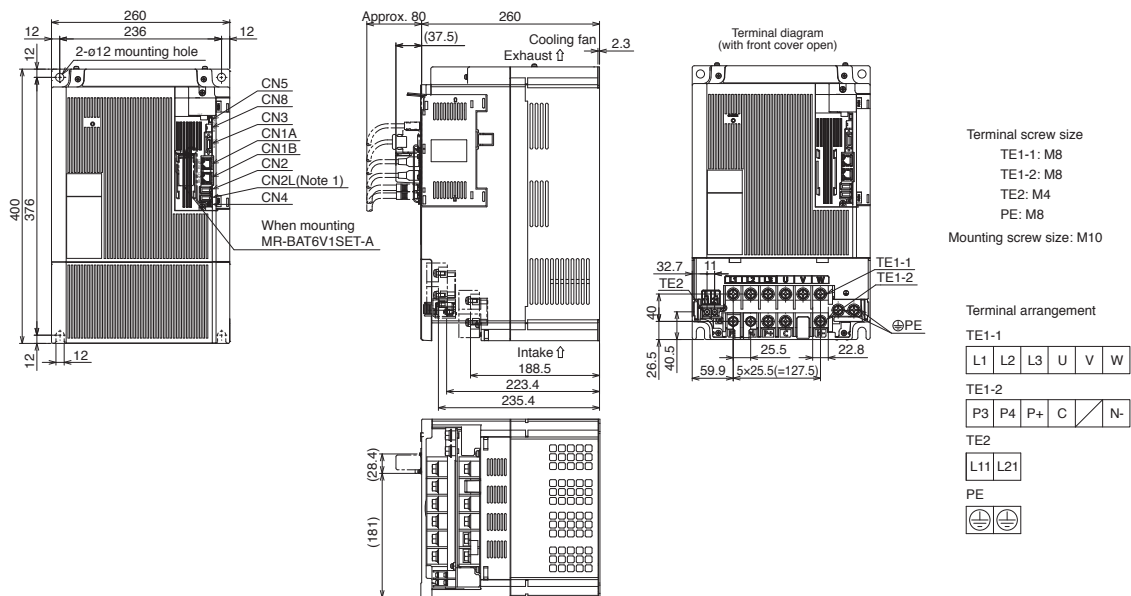

[Unit: mm]

Notes: 1. CN2L, CN7, and CN9 connectors are not available for MR-J4-GF servo amplifier.

Servo Amplifiers  
 Rotary Servo Motors  
 Linear Servo Motors  
 Direct Drive Motors  
 Options/Peripheral Equipment  
 LV5/Wires  
 Product List  
 Precautions

# Servo Amplifiers

## MR-J4-B/MR-J4-B-RJ Connections with Peripheral Equipment (Note 1)

**B B-RJ**

Peripheral equipment is connected to MR-J4-B/MR-J4-B-RJ as described below. Connectors, cables, options, and other necessary equipment are available so that users can set up the servo amplifier easily and start using it right away.

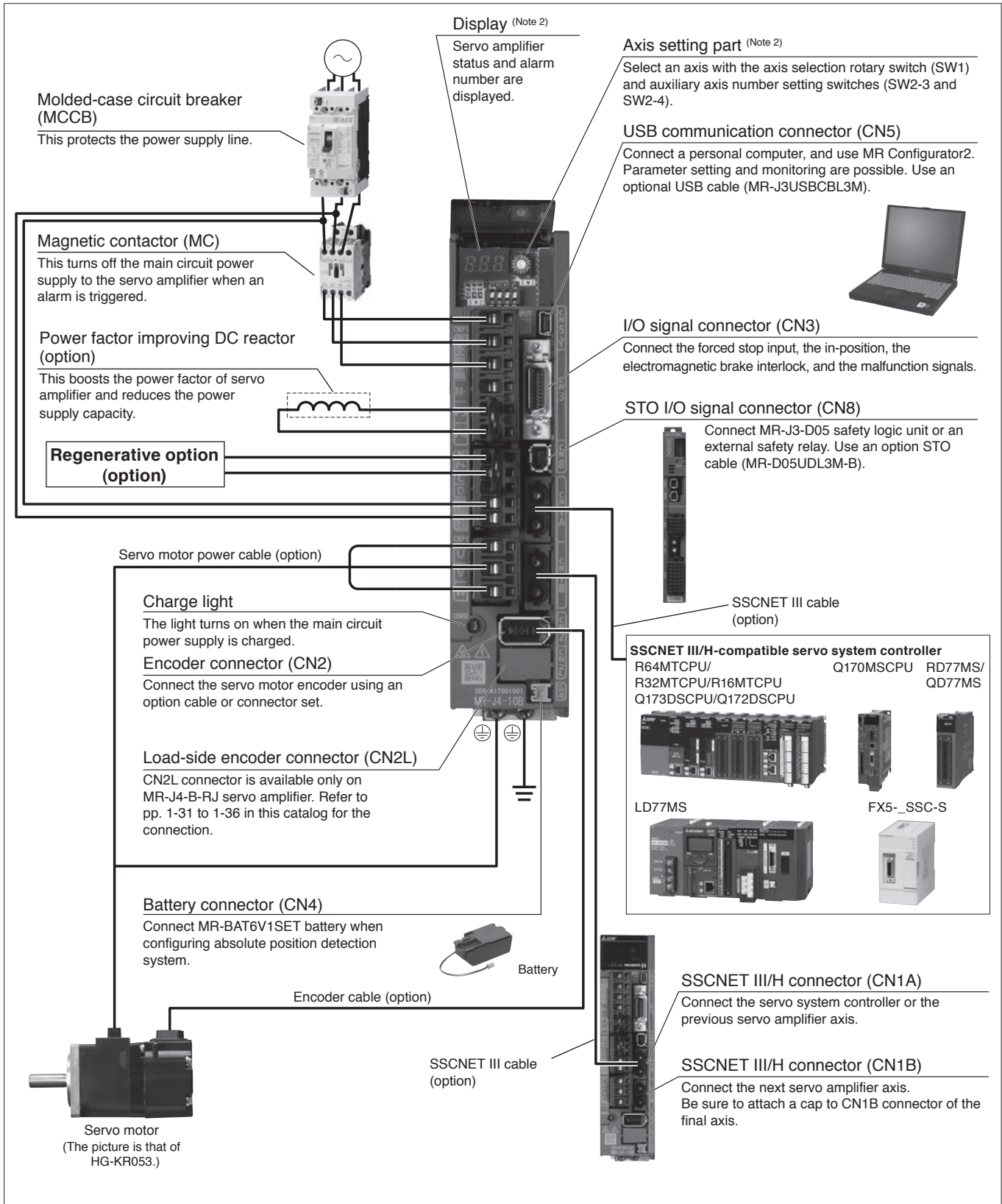

Notes: 1. The connection with the peripheral equipment is an example for MR-J4-350B/MR-J4-350B-RJ or smaller servo amplifiers. Refer to "MR-J4-\_B\_(-RJ) Servo Amplifier Instruction Manual" for the actual connections.  
2. This picture shows when the display cover is open.

MR-J4-B(1)/MR-J4-B(1)-RJ (SSCNET III/H Interface) Specifications (200 V/100 V)

B B-RJ

Servo amplifier model MR-J4-(-RJ)		10B	20B	40B	60B	70B	100B	200B	350B	500B	700B	11KB	15KB	22KB	10B1	20B1	40B1	
Output	Rated voltage	3-phase 170 V AC																
	Rated current [A]	1.1	1.5	2.8	3.2	5.8	6.0	11.0	17.0	28.0	37.0	68.0	87.0	126.0	1.1	1.5	2.8	
Main circuit power supply input	Voltage/frequency (Note 1)	AC input	3-phase or 1-phase 200 V AC to 240 V AC, 50 Hz/60 Hz						3-phase or 1-phase 200 V AC to 240 V AC, 50 Hz/60 Hz (Note 17)			3-phase 200 V AC to 240 V AC, 50 Hz/60 Hz				1-phase 100 V AC to 120 V AC, 50 Hz/60 Hz		
		DC input (Note 19)	283 V DC to 340 V DC															
	Rated current (Note 15) [A]	0.9 (1.5)	1.5 (2.5)	2.6 (4.5)	3.2 (5.0) (Note 8)	3.8 (6.5)	5.0 (10.5)	10.5 (15.8)	16.0	21.7	28.9	46.0	64.0	95.0	3.0	5.0	9.0	
	Permissible voltage fluctuation	AC input	3-phase or 1-phase 170 V AC to 264 V AC						3-phase or 1-phase 170 V AC to 264 V AC (Note 17)			3-phase 170 V AC to 264 V AC				1-phase 85 V AC to 132 V AC		
		DC input (Note 19)	241 V DC to 374 V DC															
	Permissible frequency fluctuation	±5% maximum																
Control circuit power supply input	Voltage/frequency	AC input	1-phase 200 V AC to 240 V AC, 50 Hz/60 Hz												1-phase 100 V AC to 120 V AC, 50 Hz/60 Hz			
		DC input (Note 19)	283 V DC to 340 V DC															
	Rated current [A]	0.2						0.3				0.4						
	Permissible voltage fluctuation	AC input	1-phase 170 V AC to 264 V AC												1-phase 85 V AC to 132 V AC			
		DC input (Note 19)	241 V DC to 374 V DC															
	Permissible frequency fluctuation	±5% maximum																
Power consumption [W]	30						45				30							
Interface power supply	24 V DC ± 10% (required current capacity: 0.3 A (including CN8 connector signals))																	
Control method	Sine-wave PWM control/current control method																	
Permissible regenerative power	Built-in regenerative resistor (Note 2, 3) [W]	-	10	10	10	20	20	100	100	130	170	-	-	-	-	10	10	
	External regenerative resistor (standard accessory) (Note 2, 3, 11, 12) [W]	-	-	-	-	-	-	-	-	-	-	500 (800)	850 (1300)	850 (1300)	-	-	-	
Dynamic brake (Note 4)	Built-in										External option (Note 13)			Built-in				
SSCNET III/H command communication cycle (Note 10)	0.222 ms, 0.444 ms, 0.888 ms																	
Communication function	USB	Connect a personal computer (MR Configurator2 compatible)																
Encoder output pulse	Compatible (A/B/Z-phase pulse)																	
Analog monitor	2 channels																	
Fully closed loop control	MR-J4-B(1) (Note 9)	Two-wire type communication method																
	MR-J4-B(1)-RJ	Two-wire/four-wire type communication method																
Load-side encoder interface	MR-J4-B(1)	Mitsubishi Electric high-speed serial communication																
	MR-J4-B(1)-RJ	Mitsubishi Electric high-speed serial communication, A/B/Z-phase differential input signal																
Servo functions	Advanced vibration suppression control II, adaptive filter II, robust filter, auto tuning, one-touch tuning, tough drive function, drive recorder function, tightening & press-fit control, machine diagnosis function, power monitoring function, driver communication function (Note 14), scale measurement function (Note 14), J3 compatibility mode, super trace control (Note 16), lost motion compensation function (Note 16)																	
Protective functions	Overcurrent shut-off, regenerative overvoltage shut-off, overload shut-off (electronic thermal), servo motor overheat protection, encoder error protection, regenerative error protection, undervoltage protection, instantaneous power failure protection, overspeed protection, error excessive protection, magnetic pole detection protection, linear servo control fault protection																	

Servo Amplifiers

Rotary Servo Motors

Linear Servo Motors

Direct Drive Motors

Options/Peripheral Equipment

I/O Wires

Product List

Precautions

# Servo Amplifiers

## MR-J4-B(1)/MR-J4-B(1)-RJ (SSCNET III/H Interface) Specifications (200 V/100 V)

**B** **B-RJ**

Servo amplifier model MR-J4-_-(-RJ)		10B	20B	40B	60B	70B	100B	200B	350B	500B	700B	11KB	15KB	22KB	10B1	20B1	40B1
Functional safety		STO (IEC/EN 61800-5-2)															
Safety performance	Satisfied standards <sup>(Note 20)</sup>	EN ISO 13849-1:2015 Category 3 PL e, IEC 61508 SIL 3, EN IEC 62061 maximum SIL 3, EN 61800-5-2															
	Response performance	8 ms or less (STO input OFF → energy shut-off)															
	Test pulse input (STO) <sup>(Note 7)</sup>	Test pulse interval: 1 Hz to 25 Hz, test pulse off time: 1 ms maximum															
	Mean time to dangerous failure (MTTFd)	MTTFd ≥ 100 [years] (314a)															
	Diagnostic coverage (DC)	DC = Medium, 97.6 [%]															
Probability of dangerous Failure per Hour (PFH)		PFH = 6.4 × 10 <sup>-9</sup> [1/h]															
Structure (IP rating)		Natural cooling, open (IP20)				Force cooling, open (IP20)				Force cooling, open (IP20) <sup>(Note 5)</sup>				Natural cooling, open (IP20)			
Close mounting	3-phase power input	Possible <sup>(Note 6)</sup>						Not possible						-			
	1-phase power input	Possible <sup>(Note 6)</sup>				Not possible				-				Possible <sup>(Note 6)</sup>			
Environment	Ambient temperature	Operation: 0 °C to 55 °C (non-freezing), storage: -20 °C to 65 °C (non-freezing)															
	Ambient humidity	Operation/storage: 5 %RH to 90 %RH (non-condensing)															
	Ambience	Indoors (no direct sunlight); no corrosive gas, inflammable gas, oil mist or dust															
	Altitude	2000 m or less above sea level <sup>(Note 18)</sup>															
Vibration resistance		5.9 m/s <sup>2</sup> at 10 Hz to 55 Hz (directions of X, Y, and Z axes)															
Mass [kg]		0.8	0.8	1.0	1.0	1.4	1.4	2.1	2.3	4.0	6.2	13.4	13.4	18.2	0.8	0.8	1.0

- Notes: 1. Rated output and speed of a rotary servo motor and a direct drive motor; and continuous thrust and maximum speed of a linear servo motor are applicable when the servo amplifier is operated within the specified power supply voltage and frequency.
2. Select the most suitable regenerative option for your system with our drive system sizing software Motorizer.
3. Refer to "Regenerative Option" in this catalog for the permissible regenerative power [W] when a regenerative option is used.
4. When using the dynamic brake, refer to "MR-J4-\_B\_(-RJ) Servo Amplifier Instruction Manual" for the permissible load to motor inertia ratio and the permissible load to mass ratio.
5. Terminal blocks are excluded.
6. When the servo amplifiers are closely mounted, keep the ambient temperature within 0 °C to 45 °C, or use the servo amplifiers at 75% or less of the effective load ratio.
7. The test pulse is a signal for the external circuit to perform self-diagnosis by turning off the signals to the servo amplifier instantaneously at regular intervals.
8. The rated current is 2.9 A when the servo amplifier is used with a 3-phase power supply and combined with UL or CSA compliant servo motor.
9. Fully closed loop control is supported by the servo amplifiers with software version A3 or later.
10. The command communication cycle depends on the servo system controller specifications and the number of axes connected.
11. The value in brackets is applicable when cooling fans (two units of 92 mm × 92 mm, minimum air flow: 1.0 m<sup>3</sup>/min) are installed, and then [Pr. PA02] is changed.
12. Servo amplifiers without an enclosed regenerative resistor are also available. Refer to "Model Designation for 1-Axis Servo Amplifier" in this catalog for details.
13. Use an external dynamic brake (option) with the servo amplifier. Without the external dynamic brake, a servo motor does not stop immediately at emergency stop and falls in free-run status, causing an accident such as machine collision, etc. Take measures to ensure safety on the entire system when not using the dynamic brake.
14. This function is supported by the servo amplifiers with software version A8 or later.
15. The value in brackets indicates the rated current when a 1-phase power supply input is used.
16. This function is supported by the servo amplifiers with software version B4 or later.
17. When a 1-phase 200 V AC to 240 V AC power supply is used, use the servo amplifiers at 75% or less of the effective load ratio.
18. Refer to "MR-J4-\_B\_(-RJ) Servo Amplifier Instruction Manual" for the restrictions when using the servo amplifiers at altitude exceeding 1000 m and up to 2000 m above sea level.
19. DC power input is supported by MR-J4-\_B-RJ with software version C2 or later and MR-J4-\_B-EG. For a connection example of power supply circuit with DC input, refer to "MR-J4-\_B\_(-RJ) Servo Amplifier Instruction Manual".
20. The safety level depends on the setting value of [Pr. PF18 STO diagnosis error detection time] and whether or not STO input diagnosis is performed by TOFB output. Refer to "MR-J4-\_B\_(-RJ) Servo Amplifier Instruction Manual" for details.

MR-J4-DU\_B/MR-J4-DU\_B-RJ (SSCNET III/H Interface) Specifications (200 V)

B B-RJ

Drive unit model MR-J4-_-(-RJ)		DU900B	DU11KB	DU15KB	DU22KB	DU30KB	DU37KB
Compatible converter unit model		MR-CV_				MR-CV_/MR-CR55K	
Output	Rated voltage	3-phase 170 V AC					
	Rated current [A]	54	68	87	126	174	204
Main circuit power supply input		Main circuit power is supplied from the power regeneration converter unit/ resistance regeneration converter unit to the drive unit.					
Control circuit power supply input	Voltage/frequency	1-phase 200 V AC to 240 V AC, 50 Hz/60 Hz					
	Rated current [A]	0.3					
	Permissible voltage fluctuation	1-phase 170 V AC to 264 V AC					
	Permissible frequency fluctuation	±5% maximum					
	Power consumption [W]	45					
Interface power supply		24 V DC ± 10% (required current capacity: 0.3 A (including CN8 connector signals))					
Control method		Sine-wave PWM control/current control method					
Dynamic brake <sup>(Note 7)</sup>		External option <sup>(Note 4)</sup>					
SSCNET III/H command communication cycle <sup>(Note 3)</sup>		0.222 ms, 0.444 ms, 0.888 ms					
Communication function		USB Connect a personal computer (MR Configurator2 compatible)					
Encoder output pulse		Compatible (A/B/Z-phase pulse)					
Analog monitor		2 channels					
Fully closed loop control	MR-J4-DU_B	Two-wire type communication method					
	MR-J4-DU_B-RJ	Two-wire/four-wire type communication method					
Load-side encoder interface	MR-J4-DU_B	Mitsubishi Electric high-speed serial communication					
	MR-J4-DU_B-RJ	Mitsubishi Electric high-speed serial communication, A/B/Z-phase differential input signal					
Servo functions		Advanced vibration suppression control II, adaptive filter II, robust filter, auto tuning, one-touch tuning, tough drive function, drive recorder function, tightening & press-fit control, machine diagnosis function, power monitoring function, driver communication function, scale measurement function, J3 compatibility mode, super trace control, lost motion compensation function					
Protective functions		Overcurrent shut-off, overload shut-off (electronic thermal), servo motor overheat protection, encoder error protection, undervoltage protection, instantaneous power failure protection, overspeed protection, error excessive protection, magnetic pole detection protection, linear servo control fault protection					
Functional safety		STO (IEC/EN 61800-5-2)					
Safety performance	Satisfied standards <sup>(Note 6)</sup>	EN ISO 13849-1:2015 Category 3 PL e, IEC 61508 SIL 3, EN IEC 62061 maximum SIL 3, EN 61800-5-2					
	Response performance	8 ms or less (STO input OFF → energy shut-off)					
	Test pulse input (STO) <sup>(Note 2)</sup>	Test pulse interval: 1 Hz to 25 Hz, test pulse off time: 1 ms maximum					
	Mean time to dangerous failure (MTTFd)	MTTFd ≥ 100 [years] (314a)					
	Diagnostic coverage (DC)	DC = Medium, 97.6 [%]					
	Probability of dangerous Failure per Hour (PFH)	PFH = 6.4 × 10 <sup>-9</sup> [1/h]					
Structure (IP rating)		Force cooling, open (IP20) <sup>(Note 1)</sup>					
Environment	Ambient temperature	Operation: 0 °C to 55 °C (non-freezing), storage: -20 °C to 65 °C (non-freezing)					
	Ambient humidity	Operation/storage: 5 %RH to 90 %RH (non-condensing)					
	Ambience	Indoors (no direct sunlight); no corrosive gas, inflammable gas, oil mist or dust					
	Altitude	2000 m or less above sea level <sup>(Note 5)</sup>					
	Vibration resistance	5.9 m/s <sup>2</sup> at 10 Hz to 55 Hz (directions of X, Y, and Z axes)					
Mass [kg]	9.9	9.9	15.2	15.2	21	21	

Notes: 1. Terminal blocks are excluded.

- The test pulse is a signal for the external circuit to perform self-diagnosis by turning off the signals to the drive unit instantaneously at regular intervals.
- The command communication cycle depends on the servo system controller specifications and the number of axes connected.
- Use an external dynamic brake (option) with the drive unit. Without the external dynamic brake, a servo motor does not stop immediately at emergency stop and falls in free-run status, causing an accident such as machine collision, etc. Take measures to ensure safety on the entire system when not using the dynamic brake.
- Refer to relevant "MR-CV\_ MR-CR55K\_ MR-J4-DU\_B\_(-RJ) MR-J4-DU\_A\_(-RJ) Instruction Manual" for the restrictions when using the servo amplifiers at altitude exceeding 1000 m and up to 2000 m above sea level.
- The safety level depends on the setting value of [Pr. PF18 STO diagnosis error detection time] and whether or not STO input diagnosis is performed by TOFB output. Refer to "MR-J4-\_-(-RJ) Servo Amplifier Instruction Manual" for details.
- When using the dynamic brake, refer to "MR-CV\_ MR-CR55K\_ MR-J4-DU\_B\_(-RJ) MR-J4-DU\_A\_(-RJ) Instruction Manual" for the permissible load to motor inertia ratio and the permissible load to mass ratio.

Servo Amplifiers

Rotary Servo Motors

Linear Servo Motors

Direct Drive Motors

Options/Peripheral Equipment

LVS/Wires

Product List

Precautions

# Servo Amplifiers

## MR-J4-B4/MR-J4-B4-RJ (SSCNET III/H Interface) Specifications (400 V)

**B** **B-RJ**

Servo amplifier model MR-J4-_-(-RJ)		60B4	100B4	200B4	350B4	500B4	700B4	11KB4	15KB4	22KB4
Output	Rated voltage	3-phase 323 V AC								
	Rated current [A]	1.5	2.8	5.4	8.6	14.0	17.0	32.0	41.0	63.0
Main circuit power supply input	Voltage/frequency <sup>(Note 1)</sup>	3-phase 380 V AC to 480 V AC, 50 Hz/60 Hz								
	Rated current [A]	1.4	2.5	5.1	7.9	10.8	14.4	23.1	31.8	47.6
	Permissible voltage fluctuation	3-phase 323 V AC to 528 V AC								
	Permissible frequency fluctuation	±5% maximum								
	Voltage/frequency	1-phase 380 V AC to 480 V AC, 50 Hz/60 Hz								
Control circuit power supply input	Rated current [A]	0.1			0.2					
	Permissible voltage fluctuation	1-phase 323 V AC to 528 V AC								
	Permissible frequency fluctuation	±5% maximum								
	Power consumption [W]	30			45					
Interface power supply		24 V DC ± 10% (required current capacity: 0.3 A (including CN8 connector signals))								
Control method		Sine-wave PWM control/current control method								
Permissible regenerative power	Built-in regenerative resistor <sup>(Note 2, 3)</sup> [W]	15	15	100	100	130 <sup>(Note 11)</sup>	170 <sup>(Note 11)</sup>	-	-	-
	External regenerative resistor (standard accessory) <sup>(Note 2, 3, 8, 9)</sup> [W]	-	-	-	-	-	-	500 (800)	850 (1300)	850 (1300)
Dynamic brake <sup>(Note 4)</sup>		Built-in						External option <sup>(Note 10)</sup>		
SSCNET III/H command communication cycle <sup>(Note 7)</sup>		0.222 ms, 0.444 ms, 0.888 ms								
Communication function		USB								
Encoder output pulse		Connect a personal computer (MR Configurator2 compatible)								
Analog monitor		Compatible (A/B/Z-phase pulse)								
Fully closed loop control		2 channels								
Load-side encoder interface	MR-J4-B4	Two-wire type communication method								
	MR-J4-B4-RJ	Two-wire/four-wire type communication method								
Servo functions	MR-J4-B4	Mitsubishi Electric high-speed serial communication								
	MR-J4-B4-RJ	Mitsubishi Electric high-speed serial communication, A/B/Z-phase differential input signal								
Protective functions		Advanced vibration suppression control II, adaptive filter II, robust filter, auto tuning, one-touch tuning, tough drive function, drive recorder function, tightening & press-fit control, machine diagnosis function, power monitoring function, driver communication function <sup>(Note 12)</sup> , scale measurement function <sup>(Note 12)</sup> , J3 compatibility mode, super trace control <sup>(Note 13)</sup> , lost motion compensation function <sup>(Note 13)</sup>								
Functional safety		Overcurrent shut-off, regenerative overvoltage shut-off, overload shut-off (electronic thermal), servo motor overheat protection, encoder error protection, regenerative error protection, undervoltage protection, instantaneous power failure protection, overspeed protection, error excessive protection, magnetic pole detection protection, linear servo control fault protection								
Safety performance		STO (IEC/EN 61800-5-2)								
Structure (IP rating)	Satisfied standards <sup>(Note 15)</sup>	EN ISO 13849-1:2015 Category 3 PL e, IEC 61508 SIL 3, EN IEC 62061 maximum SIL 3, EN 61800-5-2								
	Response performance	8 ms or less (STO input OFF → energy shut-off)								
	Test pulse input (STO) <sup>(Note 6)</sup>	Test pulse interval: 1 Hz to 25 Hz, test pulse off time: 1 ms maximum								
	Mean time to dangerous failure (MTTFd)	MTTFd ≥ 100 [years] (314a)								
	Diagnostic coverage (DC)	DC = Medium, 97.6 [%]								
Close mounting		Probability of dangerous Failure per Hour (PFH) = 6.4 × 10 <sup>-9</sup> [1/h]								
Environment		Natural cooling, open (IP20)			Force cooling, open (IP20)		Force cooling, open (IP20) <sup>(Note 5)</sup>			
Ambient temperature		Not possible								
Ambient humidity		Operation: 0 °C to 55 °C (non-freezing), storage: -20 °C to 65 °C (non-freezing)								
Ambience		Operation/storage: 5 %RH to 90 %RH (non-condensing)								
Altitude		Indoors (no direct sunlight); no corrosive gas, inflammable gas, oil mist or dust								
Vibration resistance		2000 m or less above sea level <sup>(Note 14)</sup>								
Mass [kg]		5.9 m/s <sup>2</sup> at 10 Hz to 55 Hz (directions of X, Y, and Z axes)								
Mass [kg]		1.7	1.7	2.1	3.6	4.3	6.5	13.4	13.4	18.2



## MR-J4-B4/MR-J4-B4-RJ (SSCNET III/H Interface) Specifications (400 V)

B

B-RJ

- Notes: 1. Rated output and speed of a rotary servo motor, and continuous thrust and maximum speed of a linear servo motor are applicable when the servo amplifier is operated within the specified power supply voltage and frequency.
2. Select the most suitable regenerative option for your system with our drive system sizing software Motorizer.
3. Refer to "Regenerative Option" in this catalog for the permissible regenerative power [W] when a regenerative option is used.
4. When using the dynamic brake, refer to "MR-J4-\_B\_(-RJ) Servo Amplifier Instruction Manual" for the permissible load to motor inertia ratio and the permissible load to mass ratio.
5. Terminal blocks are excluded.
6. The test pulse is a signal for the external circuit to perform self-diagnosis by turning off the signals to the servo amplifier instantaneously at regular intervals.
7. The command communication cycle depends on the servo system controller specifications and the number of axes connected.
8. The value in brackets is applicable when cooling fans (two units of 92 mm × 92 mm, minimum air flow: 1.0 m<sup>3</sup>/min) are installed, and then [Pr. PA02] is changed.
9. Servo amplifiers without an enclosed regenerative resistor are also available. Refer to "Model Designation for 1-Axis Servo Amplifier" in this catalog for details.
10. Use an external dynamic brake (option) with the servo amplifier. Without the external dynamic brake, a servo motor does not stop immediately at emergency stop and falls in free-run status, causing an accident such as machine collision, etc. Take measures to ensure safety on the entire system when not using the dynamic brake.
11. The servo amplifier built-in regenerative resistor is compatible with the maximum torque deceleration when the servo motor is used within the rated speed and the recommended load to motor inertia ratio. Contact your local sales office if the operating motor speed or the load to motor inertia ratio exceeds the rated speed or the recommended ratio.
12. This function is supported by the servo amplifiers with software version A8 or later.
13. This function is supported by the servo amplifiers with software version B4 or later.
14. Refer to "MR-J4-\_B\_(-RJ) Servo Amplifier Instruction Manual" for the restrictions when using the servo amplifiers at altitude exceeding 1000 m and up to 2000 m above sea level.
15. The safety level depends on the setting value of [Pr. PF18 STO diagnosis error detection time] and whether or not STO input diagnosis is performed by TOFB output. Refer to "MR-J4-\_B\_(-RJ) Servo Amplifier Instruction Manual" for details.

Servo Amplifiers

Rotary Servo Motors

Linear Servo Motors

Direct Drive Motors

Options/Peripheral Equipment

LVS/Wires

Product List

Precautions

# Servo Amplifiers

## MR-J4-DU\_B4/MR-J4-DU\_B4-RJ (SSCNET III/H Interface) Specifications (400 V)

**B** **B-RJ**

Drive unit model MR-J4-(-RJ)		DU900B4	DU11KB4	DU15KB4	DU22KB4	DU30KB4	DU37KB4	DU45KB4	DU55KB4
Compatible converter unit model		MR-CV_4			MR-CV_4/MR-CR55K4				
Output	Rated voltage	3-phase 323 V AC							
	Rated current [A]	25	32	41	63	87	102	131	143
Main circuit power supply input		Main circuit power is supplied from the power regeneration converter unit/ resistance regeneration converter unit to the drive unit.							
Control circuit power supply input	Voltage/frequency	1-phase 380 V AC to 480 V AC, 50 Hz/60 Hz							
	Rated current [A]	0.2							
	Permissible voltage fluctuation	1-phase 323 V AC to 528 V AC							
	Permissible frequency fluctuation	±5% maximum							
	Power consumption [W]	45							
Interface power supply		24 V DC ± 10% (required current capacity: 0.3 A (including CN8 connector signals))							
Control method		Sine-wave PWM control/current control method							
Dynamic brake <sup>(Note 7)</sup>		External option <sup>(Note 4)</sup>							
SSCNET III/H command communication cycle <sup>(Note 3)</sup>		0.222 ms, 0.444 ms, 0.888 ms							
Communication function		USB Connect a personal computer (MR Configurator2 compatible)							
Encoder output pulse		Compatible (A/B/Z-phase pulse)							
Analog monitor		2 channels							
Fully closed loop control	MR-J4-DU_B4	Two-wire type communication method							
	MR-J4-DU_B4-RJ	Two-wire/four-wire type communication method							
Load-side encoder interface	MR-J4-DU_B4	Mitsubishi Electric high-speed serial communication							
	MR-J4-DU_B4-RJ	Mitsubishi Electric high-speed serial communication, A/B/Z-phase differential input signal							
Servo functions		Advanced vibration suppression control II, adaptive filter II, robust filter, auto tuning, one-touch tuning, tough drive function, drive recorder function, tightening & press-fit control, machine diagnosis function, power monitoring function, driver communication function, scale measurement function, J3 compatibility mode, super trace control, lost motion compensation function							
Protective functions		Overcurrent shut-off, overload shut-off (electronic thermal), servo motor overheat protection, encoder error protection, undervoltage protection, instantaneous power failure protection, overspeed protection, error excessive protection, magnetic pole detection protection, linear servo control fault protection							
Functional safety		STO (IEC/EN 61800-5-2)							
Safety performance	Satisfied standards <sup>(Note 6)</sup>	EN ISO 13849-1:2015 Category 3 PL e, IEC 61508 SIL 3, EN IEC 62061 maximum SIL 3, EN 61800-5-2							
	Response performance	8 ms or less (STO input OFF → energy shut-off)							
	Test pulse input (STO) <sup>(Note 2)</sup>	Test pulse interval: 1 Hz to 25 Hz, test pulse off time: 1 ms maximum							
	Mean time to dangerous failure (MTTFd)	MTTFd ≥ 100 [years] (314a)							
	Diagnostic coverage (DC)	DC = Medium, 97.6 [%]							
	Probability of dangerous Failure per Hour (PFH)	PFH = 6.4 × 10 <sup>-9</sup> [1/h]							
Structure (IP rating)		Force cooling, open (IP20) <sup>(Note 1)</sup>							
Environment	Ambient temperature	Operation: 0 °C to 55 °C (non-freezing), storage: -20 °C to 65 °C (non-freezing)							
	Ambient humidity	Operation/storage: 5 %RH to 90 %RH (non-condensing)							
	Ambience	Indoors (no direct sunlight); no corrosive gas, inflammable gas, oil mist or dust							
	Altitude	2000 m or less above sea level <sup>(Note 5)</sup>							
	Vibration resistance	5.9 m/s <sup>2</sup> at 10 Hz to 55 Hz (directions of X, Y, and Z axes)							
Mass [kg]	9.9	9.9	15.2	15.2	16	16	21	21	

Notes: 1. Terminal blocks are excluded.

2. The test pulse is a signal for the external circuit to perform self-diagnosis by turning off the signals to the drive unit instantaneously at regular intervals.

3. The command communication cycle depends on the servo system controller specifications and the number of axes connected.

4. Use an external dynamic brake (option) with the drive unit. Without the external dynamic brake, a servo motor does not stop immediately at emergency stop and falls in free-run status, causing an accident such as machine collision, etc. Take measures to ensure safety on the entire system when not using the dynamic brake.

5. Refer to "MR-CV\_ MR-CR55K\_ MR-J4-DU\_B\_(-RJ) MR-J4-DU\_A\_(-RJ) Instruction Manual" for the restrictions when using the servo amplifiers at altitude exceeding 1000 m and up to 2000 m above sea level.

6. The safety level depends on the setting value of [Pr. PF18 STO diagnosis error detection time] and whether or not STO input diagnosis is performed by TOFB output. Refer to "MR-J4\_B\_(-RJ) Servo Amplifier Instruction Manual" for details.

7. When using the dynamic brake, refer to "MR-CV\_ MR-CR55K\_ MR-J4-DU\_B\_(-RJ) MR-J4-DU\_A\_(-RJ) Instruction Manual" for the permissible load to motor inertia ratio and the permissible load to mass ratio.

MR-J4-DU\_B4-RJ100 (SSCNET III/H Interface) Specifications (400 V)

Drive unit model MR-J4_		DU45KB4-RJ100	DU55KB4-RJ100
Compatible power regeneration converter unit model		MR-CV55K4 (Note 5)	
Output	Rated voltage	3-phase 323 V AC	
	Rated current [A]	131	143
Main circuit power supply input		Main circuit power is supplied from the power regeneration converter unit to the drive unit.	
Control circuit power supply input	Voltage/frequency	1-phase 380 V AC to 480 V AC, 50 Hz/60 Hz	
	Rated current [A]	0.2	
	Permissible voltage fluctuation	1-phase 323 V AC to 528 V AC	
	Permissible frequency fluctuation	±5% maximum	
	Power consumption [W]	45	
Interface power supply		24 V DC ± 10% (required current capacity: 0.3 A (including CN8 connector signals))	
Control method		Sine-wave PWM control/current control method	
Dynamic Brake (Note 7)		External option (Note 4)	
SSCNET III/H command communication cycle (Note 3)		0.222 ms, 0.444 ms, 0.888 ms	
Communication function USB		Connect a personal computer (MR Configurator2 compatible)	
Encoder output pulse		Compatible (A/B/Z-phase pulse)	
Analog monitor		2 channels	
Fully closed loop control		Not compatible	
Servo functions		Robust filter, auto tuning, drive recorder function, tightening & press-fit control, machine diagnosis function, driver communication function, super trace control, lost motion compensation	
Protective functions		Overcurrent shut-off, overload shut-off (electronic thermal), servo motor overheat protection, encoder error protection, undervoltage protection, instantaneous power failure protection, overspeed protection, error excessive protection	
Functional safety		STO (IEC/EN 61800-5-2)	
Safety performance	Satisfied standards (Note 6)	EN ISO 13849-1:2015 Category 3 PL e, IEC 61508 SIL 3, EN IEC 62061 maximum SIL 3, EN 61800-5-2	
	Response performance	8 ms or less (STO input OFF → energy shut-off)	
	Test pulse input (STO) (Note 2)	Test pulse interval: 1 Hz to 25 Hz, test pulse off time: 1 ms maximum	
	Mean time to dangerous failure (MTTFd)	MTTFd ≥ 100 [years] (314a)	
	Diagnostic coverage (DC)	DC = Medium, 97.6 [%]	
	Probability of dangerous Failure per Hour (PFH)	PFH = 6.4 × 10 <sup>-9</sup> [1/h]	
Structure (IP rating)		Force cooling, open (IP20) (Note 1)	
Environment	Ambient temperature	Operation: 0 °C to 55 °C (non-freezing), storage: -20 °C to 65 °C (non-freezing)	
	Ambient humidity	Operation/storage: 5 %RH to 90 %RH (non-condensing)	
	Ambience	Indoors (no direct sunlight); no corrosive gas, inflammable gas, oil mist or dust	
	Altitude	2000 m or less above sea level (Note 8)	
	Vibration resistance	5.9 m/s <sup>2</sup> at 10 Hz to 55 Hz (directions of X, Y, and Z axes)	
Mass [kg]		21	

- Notes: 1. Terminal blocks are excluded.  
 2. The test pulse is a signal for the external circuit to perform self-diagnosis by turning off the signals to the drive unit instantaneously at regular intervals.  
 3. The command communication cycle depends on the servo system controller specifications and the number of axes connected.  
 4. Use one external dynamic brake (option) per drive unit. Without the external dynamic brake, a servo motor does not stop immediately at emergency stop and falls in free-run status, causing an accident such as machine collision, etc. Take measures to ensure safety on the entire system when not using the dynamic brake.  
 5. One unit of power regeneration converter unit is required for each drive unit.  
 6. The safety level depends on the setting value of [Pr. PF18 STO diagnosis error detection time] and whether or not STO input diagnosis is performed by TOFB output. Refer to "MR-CV\_ MR-CR55K\_ MR-J4-DU\_B\_(-RJ) MR-J4-DU\_A\_(-RJ) Instruction Manual" for details.  
 7. When using the dynamic brake, refer to "MR-J4-DU\_B4-RJ100 Drive Unit Instruction Manual" for the permissible load to motor inertia ratio  
 8. Refer to "MR-CV\_ MR-CR55K\_ MR-J4-DU\_B\_(-RJ) MR-J4-DU\_A\_(-RJ) Instruction Manual" for the restrictions when using the servo motors at altitude exceeding 1000 m and up to 2000 m above sea level.

Compatible Controllers

Motion controller model (Note 2)	Operation system	Note
Q172DSCPU	SW8DNC-SV22S87QL	Special OS (Note 1)
Q173DSCPU	SW8DNC-SV22S87QJ	Special OS (Note 1)
R16MTCPU	SW10DNC-RMTFW-S019	Special OS (Note 1)
R32MTCPU		

- Notes: 1. Special motion operating system is required. Ultra-large capacity servo motors cannot be driven with standard motion operating system. Contact your local sales office for more details.  
 2. This servo amplifier is not compatible with R64MTCPU.

# Servo Amplifiers

## MR-CV Power Regeneration Converter Unit Specifications (200 V)

**B** **B-RJ**

Power regeneration converter unit model MR-CV_		11K	18K	30K	37K	45K	55K
Output	Rated voltage	270 V DC to 324 V DC					
	Rated current [A]	41	76	144	164	198	238
Main circuit power supply input	Voltage/frequency <sup>(Note 1)</sup>	3-phase 200 V AC to 240 V AC, 50 Hz/60 Hz					
	Rated current [A]	35	65	107	121	148	200
	Permissible voltage fluctuation	3-phase 170 V AC to 264 V AC					
	Permissible frequency fluctuation	±3% maximum					
Control circuit power supply input	Voltage/frequency	1-phase 200 V AC to 240 V AC, 50 Hz/60 Hz					
	Rated current [A]	0.2					
	Permissible voltage fluctuation	1-phase 170 V AC to 264 V AC					
	Permissible frequency fluctuation	±3% maximum					
	Power consumption [W]	30					
Interface power supply		24 V DC ± 10% (required current capacity: 0.35 A)					
Capacity	[kW]	11	18	30	37	45	55
Protective functions		Undervoltage protection, regenerative error protection, regenerative overvoltage shut-off, MC drive circuit error protection, open-phase detection, inrush current suppression circuit error protection, main circuit device overheat error protection, cooling fan error protection, overload shut-off (electronic thermal)					
Continuous rating	[kW]	7.5	11	20	22	22	37
Instantaneous maximum rating	[kW]	39	60	92	101	125	175
Structure (IP rating)		Force cooling, open (IP20) <sup>(Note 2)</sup>					
Environment	Ambient temperature	Operation: 0 °C to 55 °C (non-freezing), storage: -20 °C to 65 °C (non-freezing)					
	Ambient humidity	Operation/storage: 5 %RH to 90 %RH (non-condensing)					
	Ambience	Indoors (no direct sunlight); no corrosive gas, inflammable gas, oil mist or dust					
	Altitude	2000 m or less above sea level <sup>(Note 3)</sup>					
	Vibration resistance	5.9 m/s <sup>2</sup> at 10 Hz to 55 Hz (directions of X, Y and Z axes)					
Mass	[kg]	6.1	6.1	12.1	12.1	12.1	25.0

Notes: 1. Rated output and speed of a rotary servo motor, and continuous thrust and maximum speed of a linear servo motor are applicable when the power regeneration converter unit is operated within the specified power supply voltage and frequency.

2. Terminal blocks are excluded.

3. Refer to "MR-CV\_ MR-CR55K\_ MR-J4-DU\_B\_(-RJ) MR-J4-DU\_A\_(-RJ) Instruction Manual" for the restrictions when using the power regeneration converter units at altitude exceeding 1000 m and up to 2000 m above sea level.

MR-CV Power Regeneration Converter Unit Specifications (400 V)

B B-RJ B-RJ100

Power regeneration converter unit model MR-CV_	11K4	18K4	30K4	37K4	45K4	55K4	75K4	
Output	Rated voltage	513 V DC to 648 V DC						
	Rated current [A]	21	38	72	82	99	119	150
Main circuit power supply input	Voltage/frequency <sup>(Note 1)</sup>	3-phase 380 V AC to 480 V AC, 50 Hz/60 Hz						
	Rated current [A]	18	35	61	70	85	106	130
	Permissible voltage fluctuation	3-phase 323 V AC to 528 V AC						
	Permissible frequency fluctuation	±3% maximum						
Control circuit power supply input	Voltage/frequency	1-phase 380 V AC to 480 V AC, 50 Hz/60 Hz						
	Rated current [A]	0.1						
	Permissible voltage fluctuation	1-phase 323 V AC to 528 V AC						
	Permissible frequency fluctuation	±3% maximum						
Interface power supply	24 V DC ± 10% (required current capacity: 0.35 A)							
Capacity [kW]	11	18	30	37	45	55	75	
Protective functions	Undervoltage protection, regenerative error protection, regenerative overvoltage shut-off, MC drive circuit error protection, open-phase detection, inrush current suppression circuit error protection, main circuit device overheat error protection, cooling fan error protection, overload shut-off (electronic thermal)							
Continuous rating [kW]	7.5	11	20	25	25	55	55	
Instantaneous maximum rating [kW]	39	60	92	101	125	175	180	
Structure (IP rating)	Force cooling, open (IP20) <sup>(Note 2)</sup>							
Environment	Ambient temperature	Operation: 0 °C to 55 °C (non-freezing), storage: -20 °C to 65 °C (non-freezing)						
	Ambient humidity	Operation/storage: 5 %RH to 90 %RH (non-condensing)						
	Ambience	Indoors (no direct sunlight); no corrosive gas, inflammable gas, oil mist or dust						
	Altitude	2000 m or less above sea level <sup>(Note 3)</sup>						
Vibration resistance	5.9 m/s <sup>2</sup> at 10 Hz to 55 Hz (directions of X, Y and Z axes)							
Mass [kg]	6.1	6.1	12.1	12.1	12.1	25.0	25.0	

Notes: 1. Rated output and speed of a rotary servo motor, and continuous thrust and maximum speed of a linear servo motor are applicable when the power regeneration converter unit is operated within the specified power supply voltage and frequency.

2. Terminal blocks are excluded.

3. Refer to "MR-CV\_ MR-CR55K\_ MR-J4-DU\_B\_(-RJ) MR-J4-DU\_A\_(-RJ) Instruction Manual" for the restrictions when using the power regeneration converter units at altitude exceeding 1000 m and up to 2000 m above sea level.

Servo Amplifiers

Rotary Servo Motors

Linear Servo Motors

Direct Drive Motors

Options/Peripheral Equipment

LVS/Wires

Product List

Precautions

# Servo Amplifiers

## MR-CR Resistance Regeneration Converter Unit Specifications

**B** **B-RJ** **A** **A-RJ**

### (200 V/400 V)

Resistance regeneration converter unit model MR-CR_		55K	55K4
Output	Rated voltage	270 V DC to 324 V DC	
	Rated current [A]	215.9	113.8
Main circuit power supply input	Voltage/frequency <sup>(Note 1)</sup>	3-phase 200 V AC to 240 V AC, 50 Hz/60 Hz	3-phase 380 V AC to 480 V AC, 50 Hz/60 Hz
	Rated current [A]	191.3	100.7
	Permissible voltage fluctuation	3-phase 170 V AC to 264 V AC	3-phase 323 V AC to 528 V AC
	Permissible frequency fluctuation	±5% maximum	
Control circuit power supply input	Voltage/frequency	1-phase 200 V AC to 240 V AC, 50 Hz/60 Hz	1-phase 380 V AC to 480 V AC, 50 Hz/60 Hz
	Rated current [A]	0.3	0.2
	Permissible voltage fluctuation	1-phase 170 V AC to 264 V AC	1-phase 323 V AC to 528 V AC
	Permissible frequency fluctuation	±5% maximum	
	Power consumption [W]	45	
Interface power supply		24 V DC ± 10% (required current capacity: 0.15 A)	
Capacity [kW]		55	
Regenerative power (when a regenerative option is used)		1300 W (one unit of MR-RB139) 3900 W (three units of MR-RB137)	1300 W (one unit of MR-RB137-4) 3900 W (three units of MR-RB13V-4)
Protective functions		Regenerative overvoltage shut-off, overload shut-off (electronic thermal), regenerative error protection, undervoltage protection, instantaneous power failure protection	
Continuous rating [kW]		55	
Structure (IP rating)		Force cooling, open (IP20) <sup>(Note 2)</sup>	
Environment	Ambient temperature	Operation: 0 °C to 55 °C (non-freezing), storage: -20 °C to 65 °C (non-freezing)	
	Ambient humidity	Operation/storage: 5 %RH to 90 %RH (non-condensing)	
	Ambience	Indoors (no direct sunlight); no corrosive gas, inflammable gas, oil mist or dust	
	Altitude	2000 m or less above sea level <sup>(Note 3)</sup>	
	Vibration resistance	5.9 m/s <sup>2</sup> at 10 Hz to 55 Hz (directions of X, Y, and Z axes)	
Mass [kg]		22	22

Notes: 1. Rated output and speed of a rotary servo motor are applicable when the resistance regeneration converter unit is operated within the specified power supply voltage and frequency.

2. Terminal blocks are excluded.

3. Refer to "MR-CV\_ MR-CR55K\_ MR-J4-DU\_B\_(-RJ) MR-J4-DU\_A\_(-RJ) Instruction Manual" for the restrictions when using the resistance regeneration converter unit at altitude exceeding 1000 m and up to 2000 m above sea level.

MR-J4-B/MR-J4-B-RJ Standard Wiring Diagram Example (Note 8)

B B-RJ

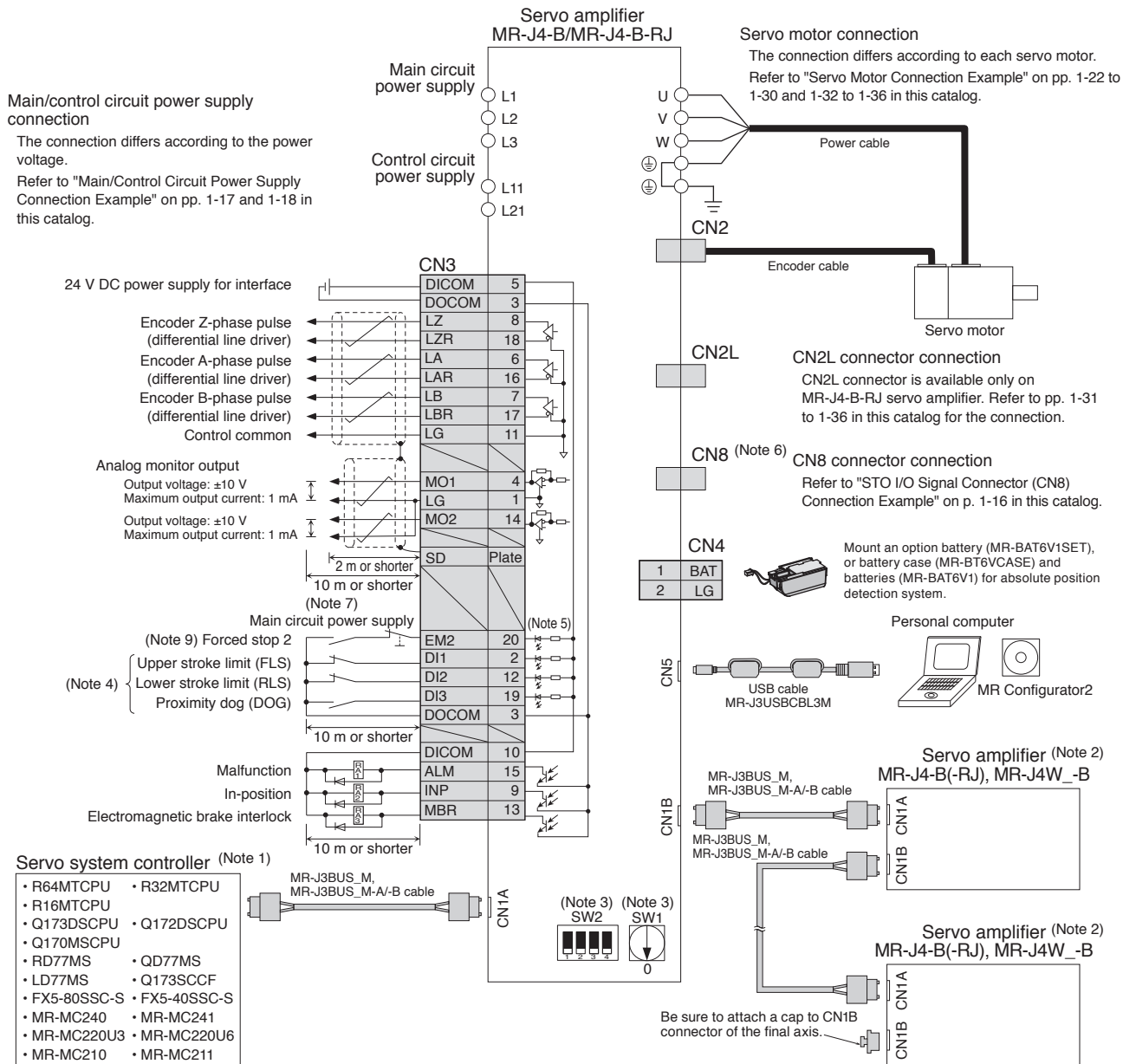

- Notes: 1. For details such as setting the servo system controllers, refer to the programming or user's manual of each controller.  
2. Connections for the second and following axes are omitted.  
3. Up to 64 axes are set with a combination of an axis selection rotary switch (SW1) and auxiliary axis number setting switches (SW2-3 and SW2-4). Note that the number of the connectable axes depends on the servo system controller specifications.  
4. Devices can be assigned to DI1, DI2 and DI3 with servo system controller setting. Refer to the controller instruction manuals for details on setting.  
5. This is for sink wiring. Source wiring is also possible.  
6. Be sure to attach a short-circuit connector supplied with the servo amplifier when the STO function is not used.  
7. To prevent an unexpected restart of the servo amplifier, create a circuit to turn off EM2 (Forced stop 2) when the main circuit power is turned off.  
8. This standard wiring diagram is common for 200 V AC, 100 V AC and 400 V AC type servo amplifiers.  
9. The forced stop signal is issued for the servo amplifier. For overall system, apply the emergency stop on the controller side.

**!** Be sure to read through Instruction Manual for the actual wiring and use. Use the equipment after you have a full knowledge of the equipment, safety information and instructions.

Servo Amplifiers  
Rotary Servo Motors  
Linear Servo Motors  
Direct Drive Motors  
Options/Peripheral Equipment  
LV5/Wires  
Product List  
Precautions

## MR-J4-DU\_B4-RJ100 System Configurations

B-RJ100

● For HG-JR110K24W0C

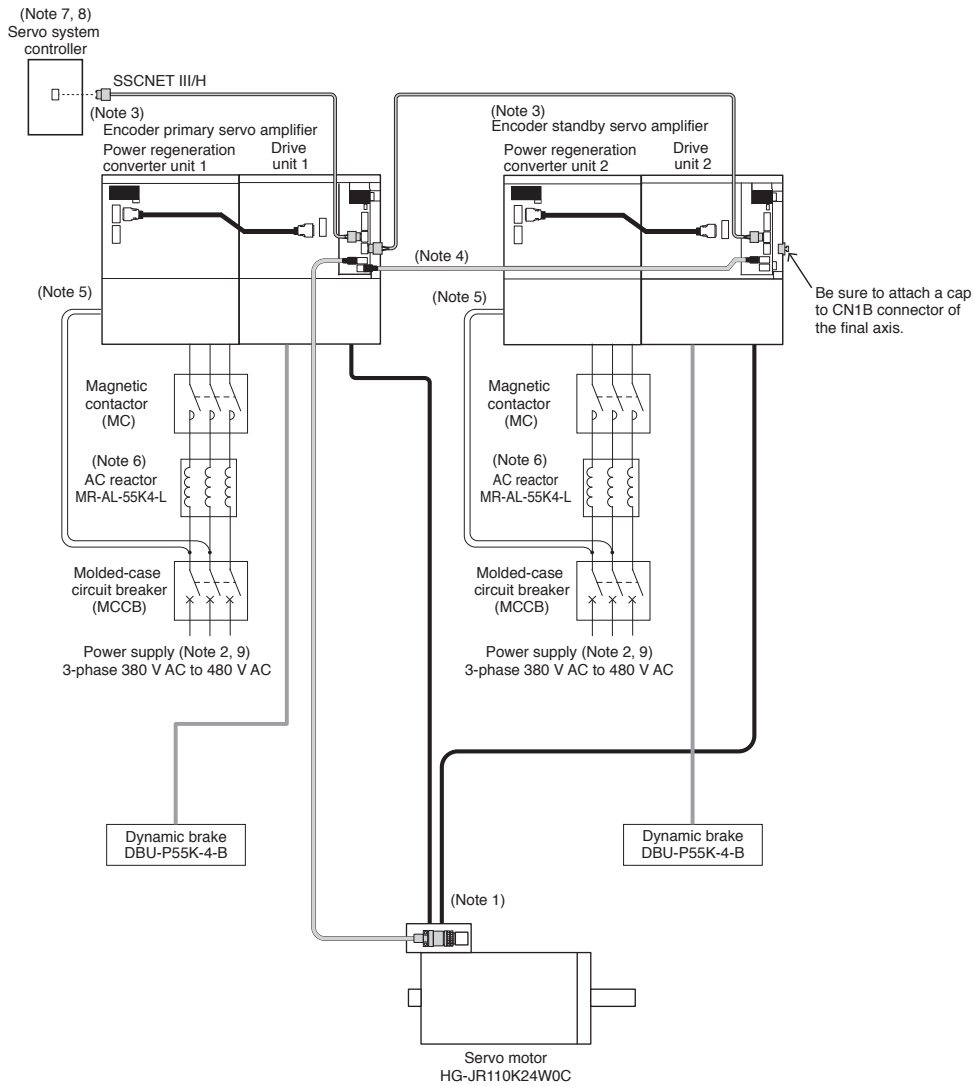

- Notes:
1. Connect the grounding wire of the servo motor only to the first drive unit. If the grounding wire is connected to two drive units, circulating current may flow to the grounding wire, depending on the wiring situation. However, if the grounding wire has to be connected to the two drive units for safety reasons, be sure to twist the U, V and W wires of each drive unit.
  2. For power supply, a molded-case circuit breaker, an AC reactor (MR-AL-55K4-L), and a magnetic contactor are required per power regeneration converter unit.
  3. For SSCNET III/H connection, connect the encoder primary servo amplifier closest to the Motion controller and then the encoder standby servo amplifier. Connect the encoder primary servo amplifier and encoder standby servo amplifier in series on the same SSCNET III/H system.
  4. Keep the encoder cable length between two drive units within 5 m.
  5. Simultaneously turn on the control circuit power supplies of all the servo amplifiers (power regeneration converter units and drive units).
  6. The AC reactor may be installed between the power regeneration converter unit and the magnetic contactor.
  7. Refer to "Compatible Controllers" on p. 1-50 in this catalog for compatible controllers. Contact your local sales office for more details.
  8. Create a sequence that stops the servo motor with the controller forced stop when an alarm occurs.
  9. All the servo amplifiers (power regeneration converter units and drive units) must be powered from a single power source. If power is supplied from different power sources, the output may be different between the encoder primary servo amplifier and the encoder standby servo amplifier, causing the servo motor to be driven improperly.



MR-J4-DU\_B4-RJ100 System Configurations

● For HG-JR150K24W0C/HG-JR180K24W0C/HG-JR200K24W0C/HG-JR220K24W0C

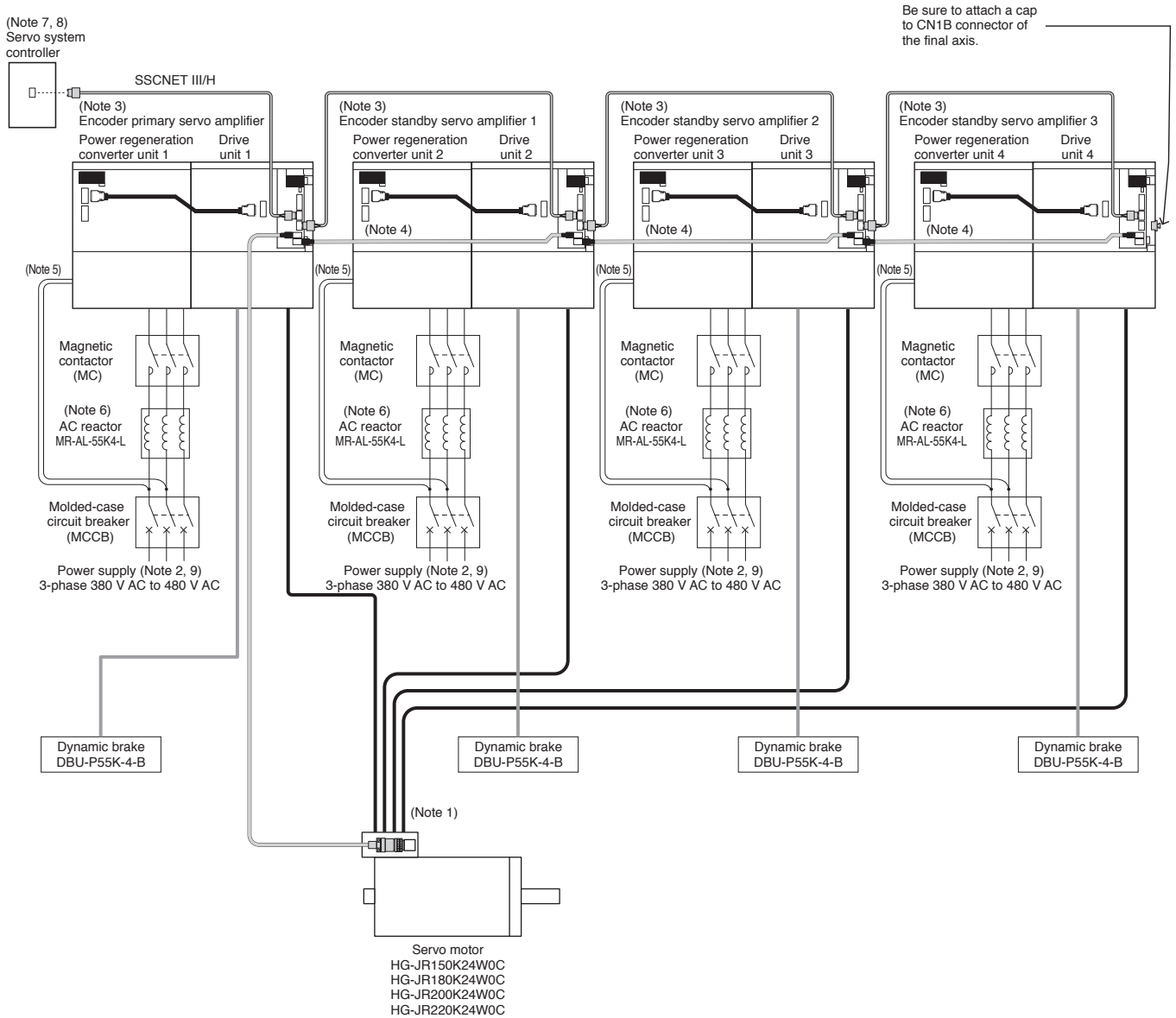

- Notes: 1. Connect the grounding wire of the servo motor only to the first drive unit. If the grounding wire is connected to two or more drive units, circulating current may flow to the grounding wire, depending on the wiring situation. However, if the grounding wire has to be connected to the two or more drive units for safety reasons, be sure to twist the U, V and W wires of each drive unit.
2. For power supply, a molded-case circuit breaker, an AC reactor (MR-AL-55K4-L), and a magnetic contactor are required per power regeneration converter unit.
3. For SSCNET III/H connection, connect the encoder primary servo amplifier closest to the Motion controller and then the encoder standby servo amplifiers. Connect the encoder primary servo amplifier and encoder standby servo amplifiers in series on the same SSCNET III/H system.
4. Keep the encoder cable length between two drive units within 5 m.
5. Simultaneously turn on the control circuit power supplies of all the servo amplifiers (power regeneration converter units and drive units).
6. The AC reactor may be installed between the power regeneration converter unit and the magnetic contactor.
7. Refer to "Compatible Controllers" on p. 1-50 in this catalog for compatible controllers. Contact your local sales office for more details.
8. Create a sequence that stops the servo motor with the controller forced stop when an alarm occurs.
9. All the servo amplifiers (power regeneration converter units and drive units) must be powered from a single power source. If power is supplied from different power sources, the output may be different between the encoder primary servo amplifier and the encoder standby servo amplifiers, causing the servo motor to be driven improperly.

# Servo Amplifiers

## MR-J4-DU\_B4-RJ100 Standard Wiring Diagram Example (Note 20)

B-RJ100

### ● Connection example for encoder primary servo amplifier

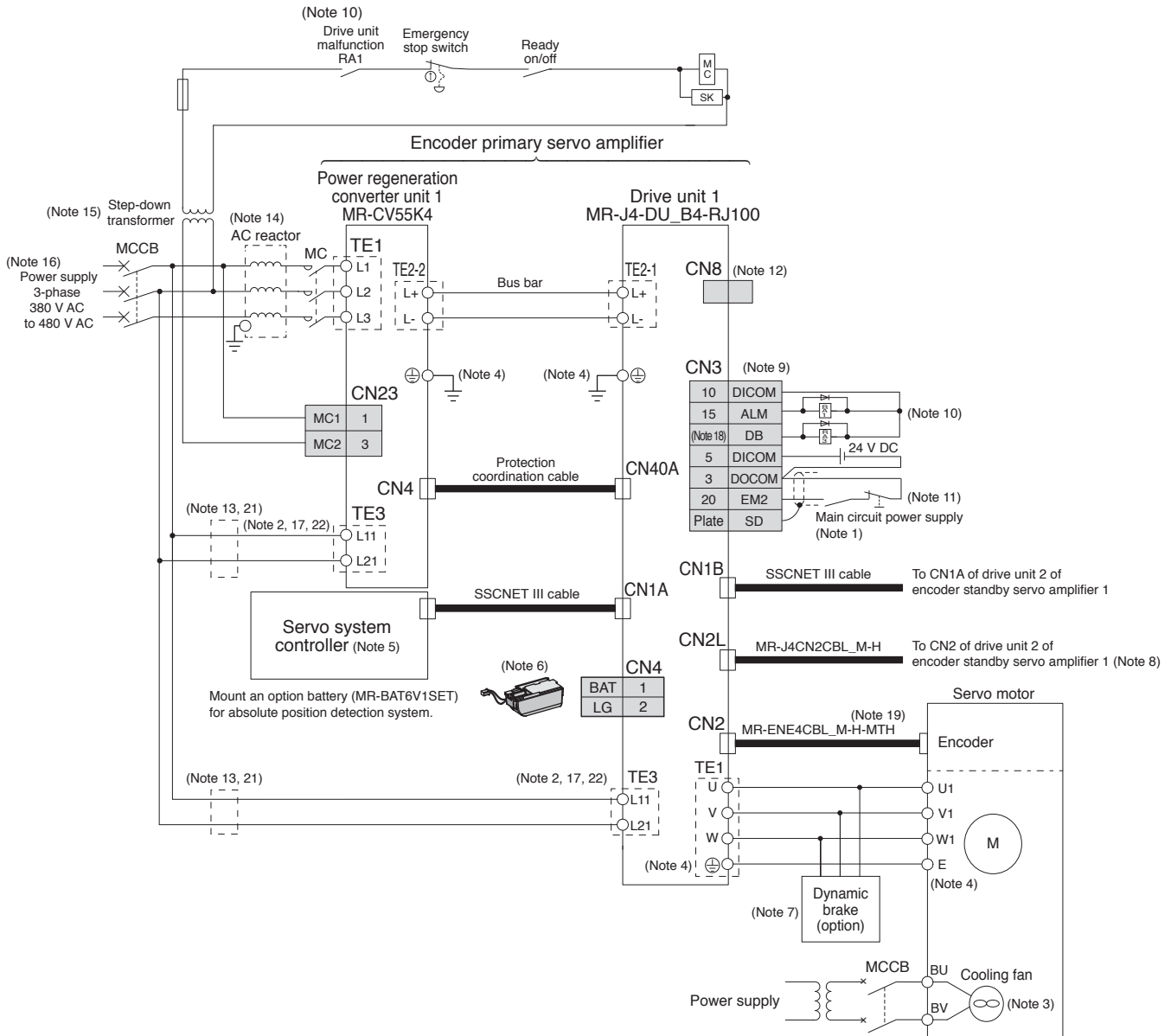

**MR-J4-DU\_B4-RJ100 Standard Wiring Diagram Example (Note 20)**

● **Connection example for encoder primary servo amplifier**

- Notes:
1. To prevent an unexpected restart of the drive unit, create a circuit to turn off EM2 (Forced stop 2) when the main circuit power is turned off.
  2. The phases of the power supply connected to L11 and L21 on the power regeneration converter unit and the drive unit must always match the phases connected to L1 and L2. An incorrect connection may damage the drive unit and the power regeneration converter unit.
  3. Be sure to supply power to the cooling fan terminals. For specifications of the cooling fan power supply and how to detect a failure, refer to "Servo Motor Instruction Manual (Vol. 3)".
  4. Connect the grounding wire of the servo motor to the drive unit. Put the grounding wires of the drive unit and the power regeneration converter unit together into one on the cabinet protective earth (PE) terminal, and then connect to ground. Connect the grounding wire of the servo motor only to the drive unit of the encoder primary servo amplifier. If the grounding wire is connected to two or more drive units, circulating current may flow to the grounding wire, depending on the wiring situation. However, if the grounding wire has to be connected to the two or more drive units for safety reasons, be sure to twist the U, V and W wires of each drive unit.
  5. Refer to "Compatible Controllers" on p. 1-50 in this catalog for compatible controllers. Contact your local sales office for more details.
  6. For absolute position detection system, connect an option battery only to the drive unit of the encoder primary servo amplifier. Do not connect the battery to the drive units of the encoder standby servo amplifiers.
  7. Use an external dynamic brake (option) with the drive unit. Without the external dynamic brake, a servo motor does not stop immediately at emergency stop and falls in free-run status, causing an accident such as machine collision, etc. Refer to "MR-J4-DU\_B4-RJ100 Drive Unit Instruction Manual" when wiring the dynamic brake.
  8. Encoder signals are distributed to all the drive units in the system via each drive unit.
  9. This is for sink wiring. Source wiring is also possible.
  10. Create a sequence that shuts off the main circuit power when an alarm occurs.
  11. Create a circuit to turn on or off EM2 (Forced stop 2) of the drive units of the encoder primary servo amplifier and encoder standby servo amplifiers simultaneously.
  12. Be sure to attach a short-circuit connector supplied with the drive unit when the STO function is not used.
  13. Install an overcurrent protection device (molded-case circuit breaker, fuse, etc.) to protect the branch circuit. Refer to "MR-CV\_MR-CR55K\_MR-J4-DU\_B(-RJ) MR-J4-DU\_A(-RJ) Instruction Manual" for details.
  14. The AC reactor may be installed between the power regeneration converter unit and the magnetic contactor.
  15. A step-down transformer is required if coil voltage of the magnetic contactor is in 200 V class.
  16. All the servo amplifiers (power regeneration converter units and drive units) must be powered from a single power source. If power is supplied from different power sources, the output may be different between the encoder primary servo amplifier and the encoder standby servo amplifiers, causing the servo motor to be driven improperly.
  17. Simultaneously turn on the control circuit power supplies of all the servo amplifiers (power regeneration converter units and drive units).
  18. The dynamic brake must be controlled by the drive unit of the encoder primary servo amplifier. Assign DB (Dynamic brake interlock) with [Pr. PD07] to [Pr. PD09].
  19. The encoder cable has thermistor signal wires. No additional wiring is required for the thermistor signal.
  20. This example is for when magnetic contactor drive output is enabled.
  21. The control circuit power supply (L11/L21) can be connected by passing wiring. Refer to "MR-CV\_MR-CR55K\_MR-J4-DU\_B(-RJ) MR-J4-DU\_A(-RJ) Instruction Manual" for details.
  22. Do not ground the servo amplifier between L11 and L21 even when the control circuit power supply is separated from the main circuit power supply using an uninterruptible power supply (UPS) or an isolation transformer.

# Servo Amplifiers

## MR-J4-DU\_B4-RJ100 Standard Wiring Diagram Example (Note 18)

B-RJ100

● Connection example for encoder standby servo amplifier (Note 3)

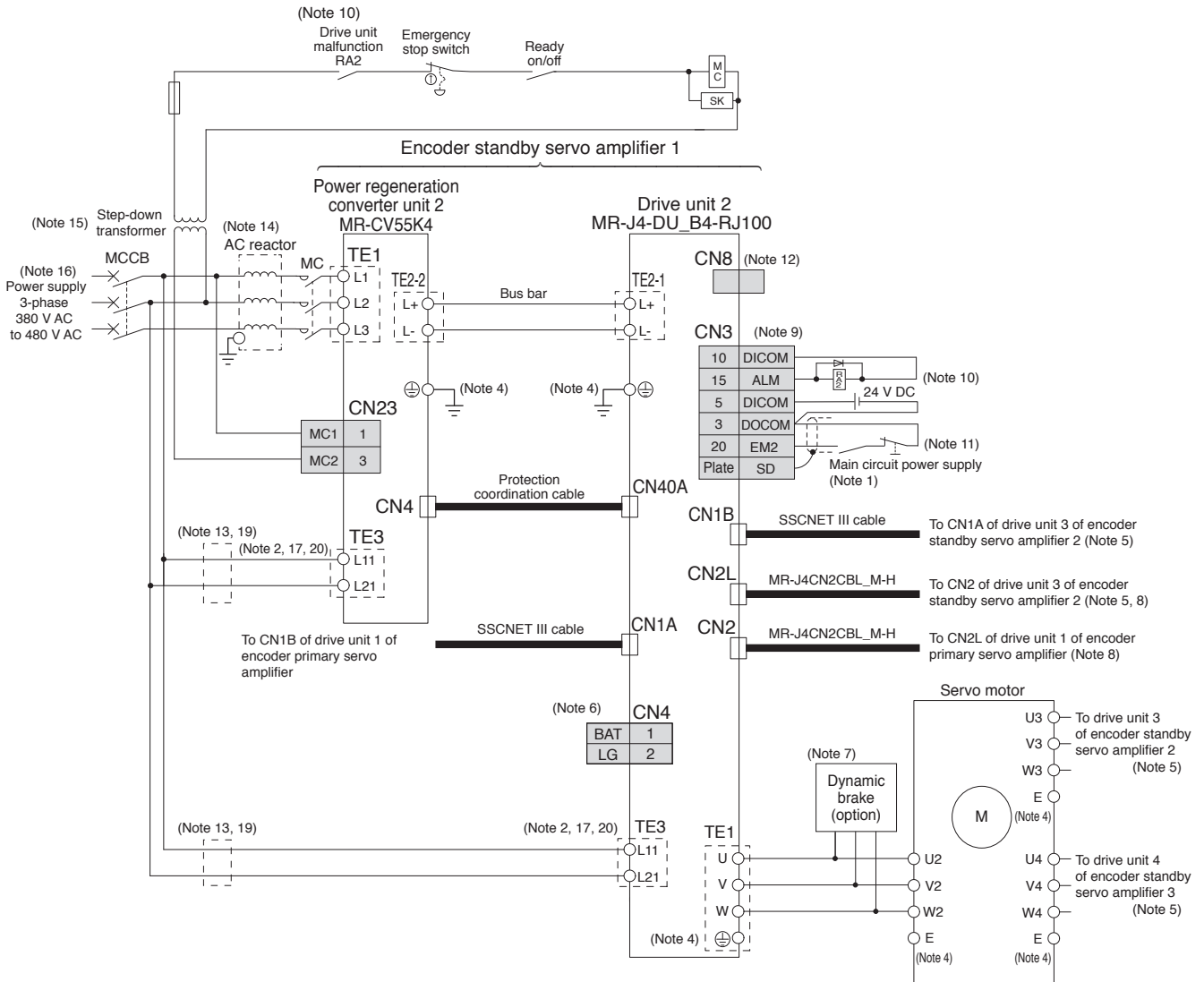

**MR-J4-DU\_B4-RJ100 Standard Wiring Diagram Example (Note 18)**

● **Connection example for encoder standby servo amplifier (Note 3)**

- Notes:
1. To prevent an unexpected restart of the drive unit, create a circuit to turn off EM2 (Forced stop 2) when the main circuit power is turned off.
  2. The phases of the power supply connected to L11 and L21 on the power regeneration converter unit and the drive unit must always match the phases connected to L1 and L2. An incorrect connection may damage the drive unit and the power regeneration converter unit.
  3. This connection is an example for the encoder standby servo amplifier 1.
  4. Connect the grounding wire of the servo motor to the drive unit. Put the grounding wires of the drive unit and the power regeneration converter unit together into one on the cabinet protective earth (PE) terminal, and then connect to ground. Connect the grounding wire of the servo motor only to the drive unit of the encoder primary servo amplifier. If the grounding wire is connected to two or more drive units, circulating current may flow to the grounding wire, depending on the wiring situation. However, if the grounding wire has to be connected to the two or more drive units for safety reasons, be sure to twist the U, V and W wires of each drive unit.
  5. This diagram is applicable when HG-JR150K24W0C, HG-JR180K24W0C, HG-JR200K24W0C, or HG-JR220K24W0C servo motor is used. For HG-JR110K24W0C, connections to drive unit 3 and 4 are not required.
  6. For absolute position detection system, connect an option battery only to the drive unit of the encoder primary servo amplifier. Do not connect the battery to the drive units of the encoder standby servo amplifiers.
  7. Use an external dynamic brake (option) with the drive unit. Without the external dynamic brake, a servo motor does not stop immediately at emergency stop and falls in free-run status, causing an accident such as machine collision, etc. Refer to "MR-J4-DU\_B4-RJ100 Drive Unit Instruction Manual" when wiring the dynamic brake.
  8. Encoder signals are distributed to all the drive units in the system via each drive unit.
  9. This is for sink wiring. Source wiring is also possible.
  10. Create a sequence that shuts off the main circuit power when an alarm occurs.
  11. Create a circuit to turn on or off EM2 (Forced stop 2) of the drive units of the encoder primary servo amplifier and encoder standby servo amplifiers simultaneously.
  12. Be sure to attach a short-circuit connector supplied with the drive unit when the STO function is not used.
  13. Install an overcurrent protection device (molded-case circuit breaker, fuse, etc.) to protect the branch circuit. Refer to "MR-CV\_MR-CR55K\_MR-J4-DU\_B\_(-RJ) MR-J4-DU\_A\_(-RJ) Instruction Manual" for details.
  14. The AC reactor may be installed between the power regeneration converter unit and the magnetic contactor.
  15. A step-down transformer is required if coil voltage of the magnetic contactor is in 200 V class.
  16. All the servo amplifiers (power regeneration converter units and drive units) must be powered from a single power source. If power is supplied from different power sources, the output may be different between the encoder primary servo amplifier and the encoder standby servo amplifiers, causing the servo motor to be driven improperly.
  17. Simultaneously turn on the control circuit power supplies of all the servo amplifiers (power regeneration converter units and drive units).
  18. This example is for when magnetic contactor drive output is enabled.
  19. The control circuit power supply (L11/L21) can be connected by passing wiring. Refer to "MR-CV\_MR-CR55K\_MR-J4-DU\_B\_(-RJ) MR-J4-DU\_A\_(-RJ) Instruction Manual" for details.
  20. Do not ground the servo amplifier between L11 and L21 even when the control circuit power supply is separated from the main circuit power supply using an uninterruptible power supply (UPS) or an isolation transformer.

# Servo Amplifiers

**B B-RJ**

## MR-J4-B/MR-J4-B-RJ Dimensions

- MR-J4-10B, MR-J4-10B-RJ, MR-J4-10B1, MR-J4-10B1-RJ
- MR-J4-20B, MR-J4-20B-RJ, MR-J4-20B1, MR-J4-20B1-RJ

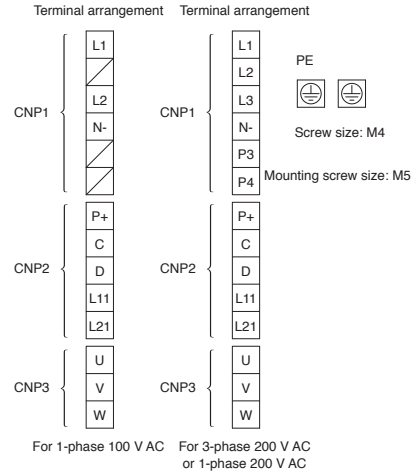
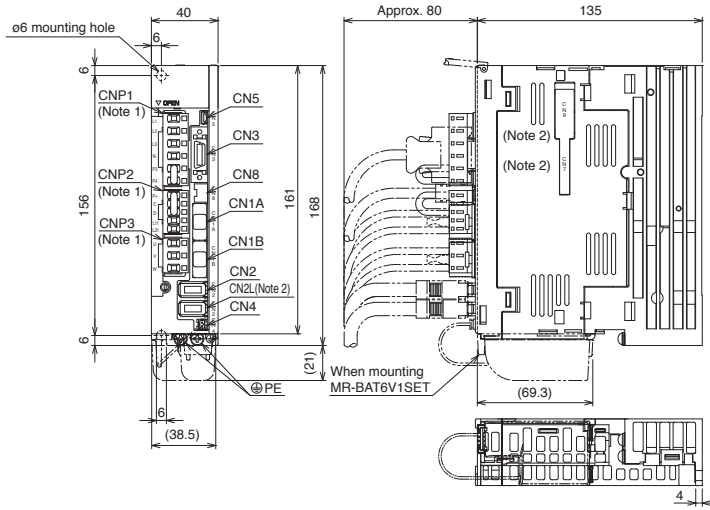

[Unit: mm]

- MR-J4-40B, MR-J4-40B-RJ, MR-J4-40B1, MR-J4-40B1-RJ
- MR-J4-60B, MR-J4-60B-RJ

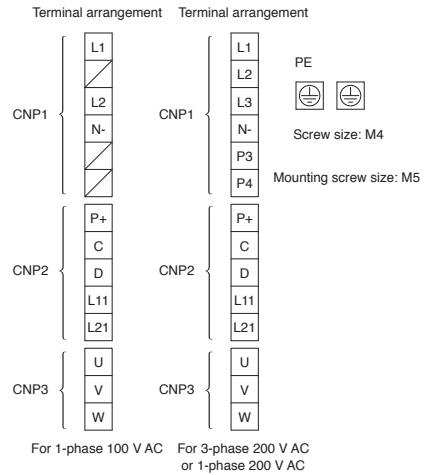
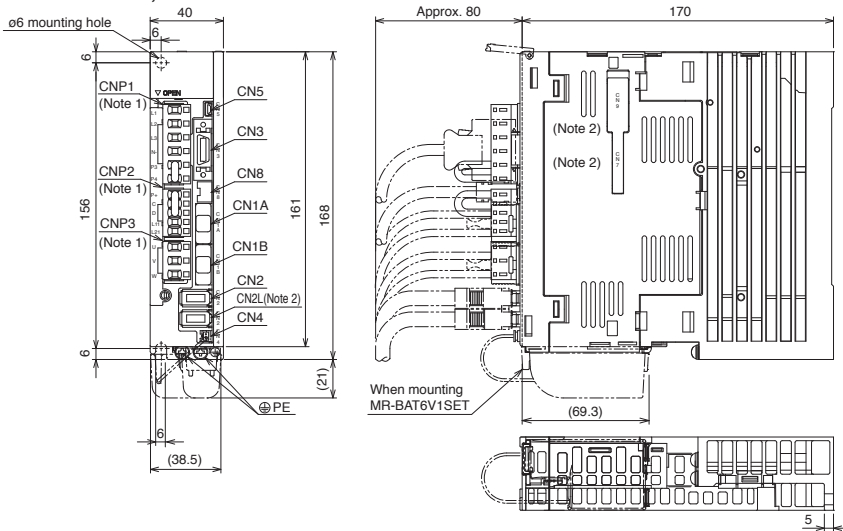

[Unit: mm]

- MR-J4-70B, MR-J4-70B-RJ
- MR-J4-100B, MR-J4-100B-RJ

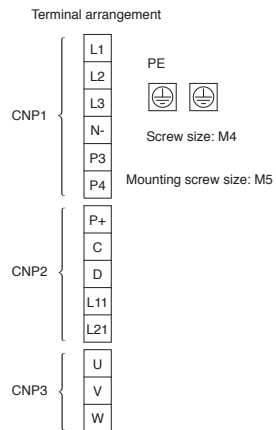
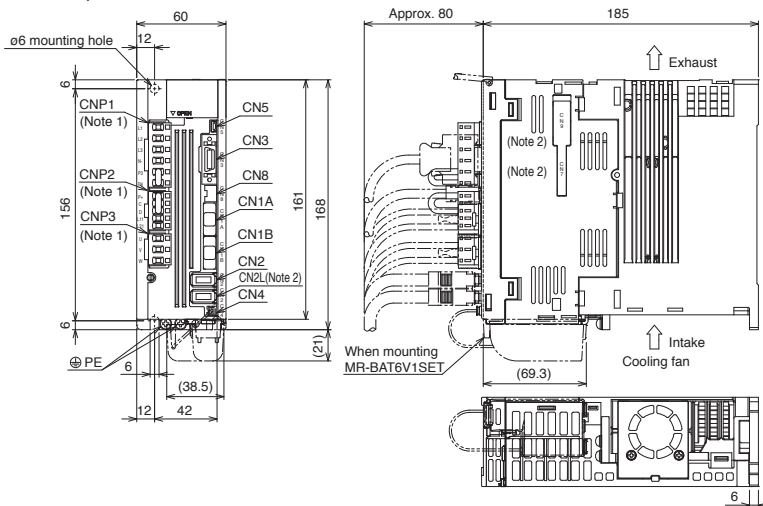

[Unit: mm]

Notes: 1. CNP1, CNP2 and CNP3 connectors are supplied with the servo amplifier.  
 2. CN2L, CN7, and CN9 connectors are not available for MR-J4-B servo amplifier.

MR-J4-B/MR-J4-B-RJ Dimensions

- MR-J4-60B4, MR-J4-60B4-RJ
- MR-J4-100B4, MR-J4-100B4-RJ

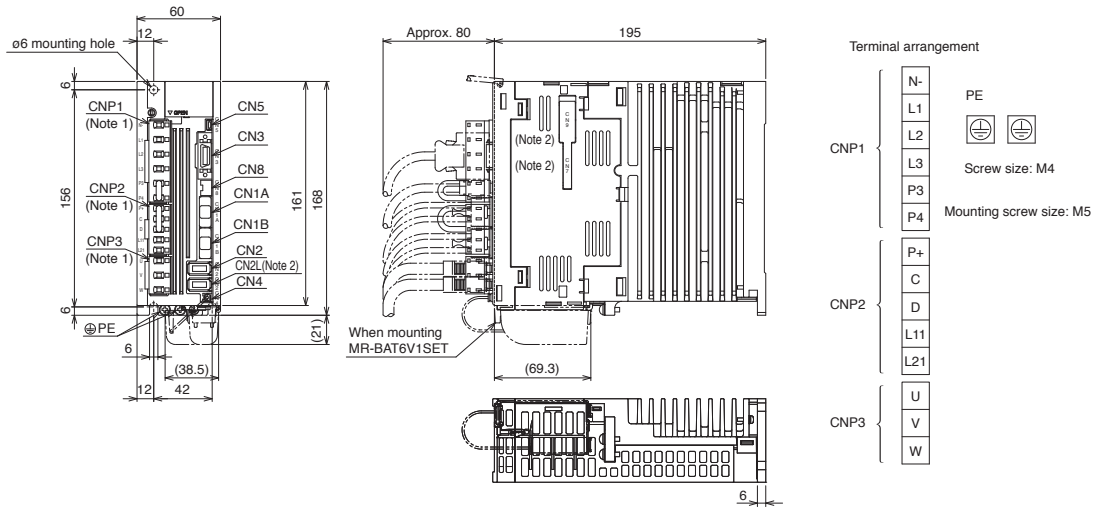

[Unit: mm]

● MR-J4-200B, MR-J4-200B-RJ

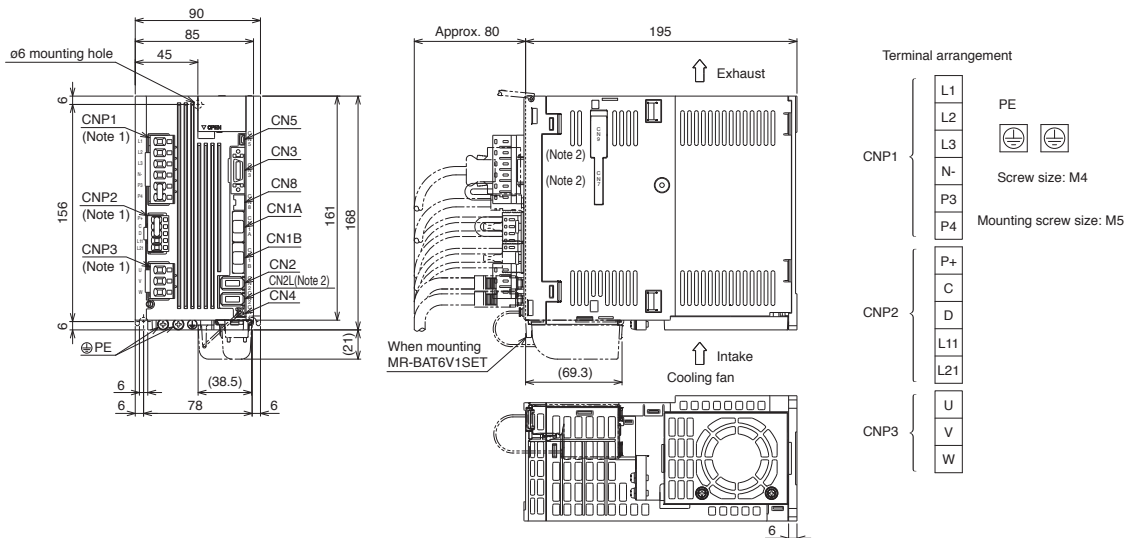

[Unit: mm]

● MR-J4-200B4, MR-J4-200B4-RJ

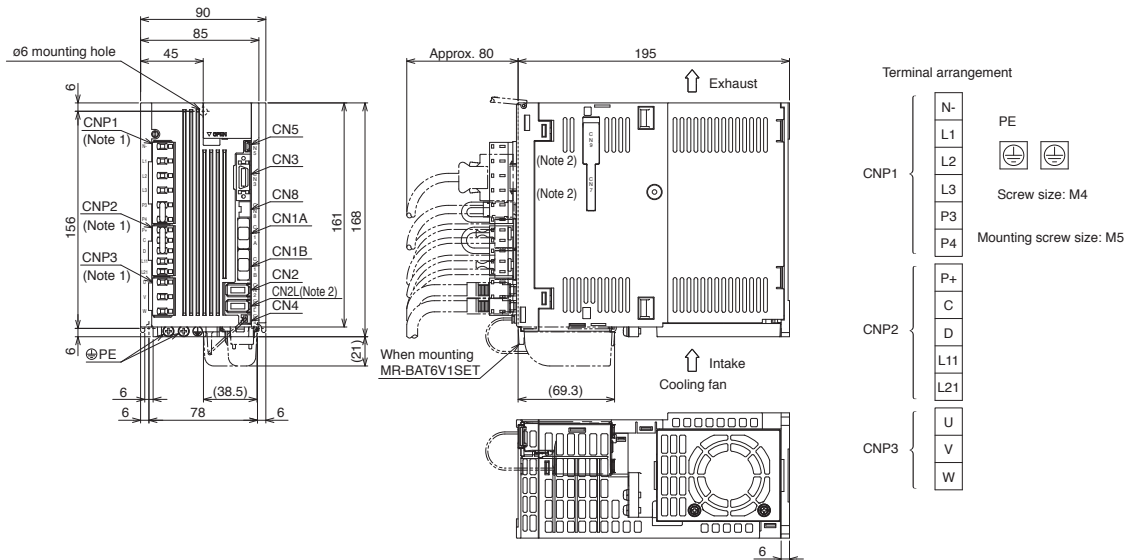

[Unit: mm]

Notes: 1. CNP1, CNP2 and CNP3 connectors are supplied with the servo amplifier.  
2. CN2L, CN7, and CN9 connectors are not available for MR-J4-B servo amplifier.

# Servo Amplifiers

## MR-J4-B/MR-J4-B-RJ Dimensions

**B B-RJ**

### ●MR-J4-350B, MR-J4-350B-RJ

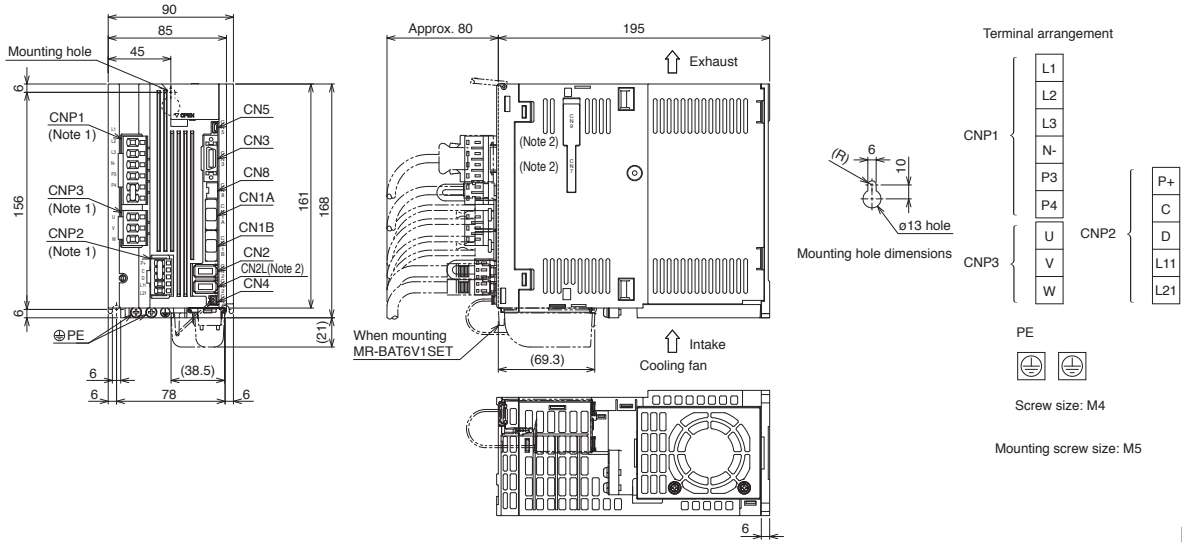

[Unit: mm]

### ●MR-J4-350B4, MR-J4-350B4-RJ

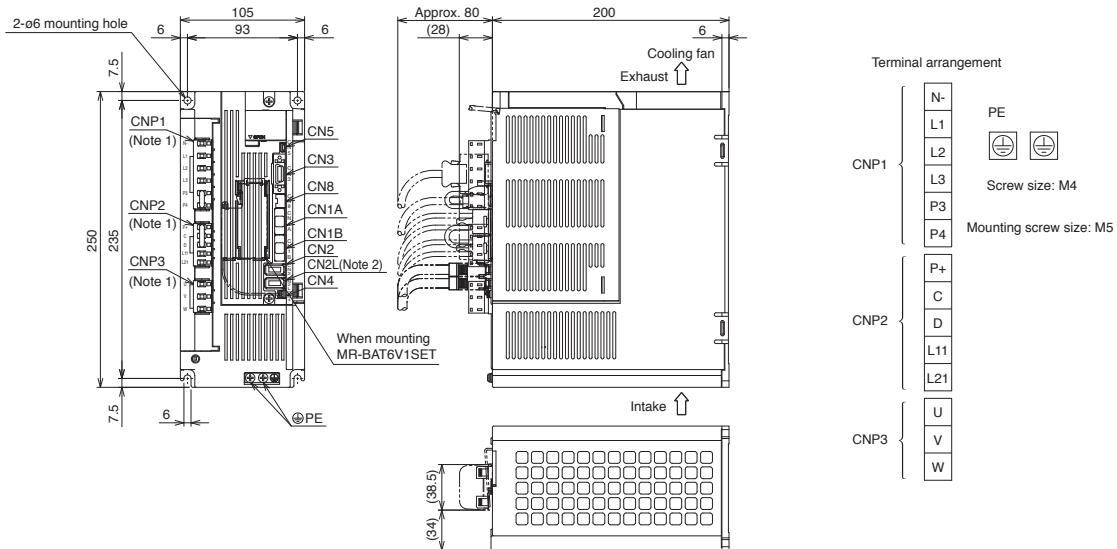

[Unit: mm]

### ●MR-J4-500B, MR-J4-500B-RJ

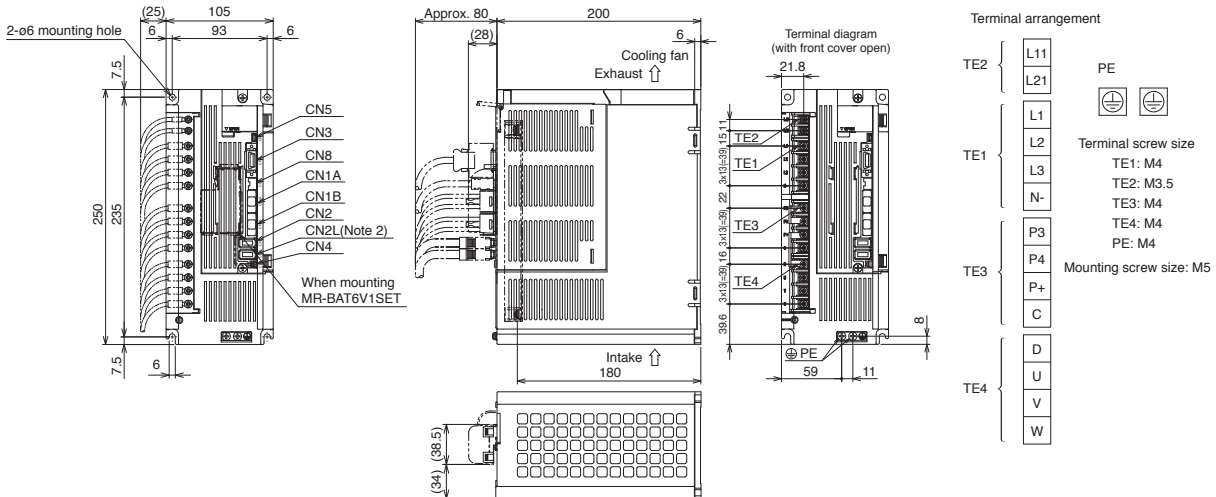

[Unit: mm]

Notes: 1. CNP1, CNP2 and CNP3 connectors are supplied with the servo amplifier.  
2. CN2L, CN7, and CN9 connectors are not available for MR-J4-B servo amplifier.



B B-RJ

MR-J4-B/MR-J4-B-RJ Dimensions

● MR-J4-500B4, MR-J4-500B4-RJ

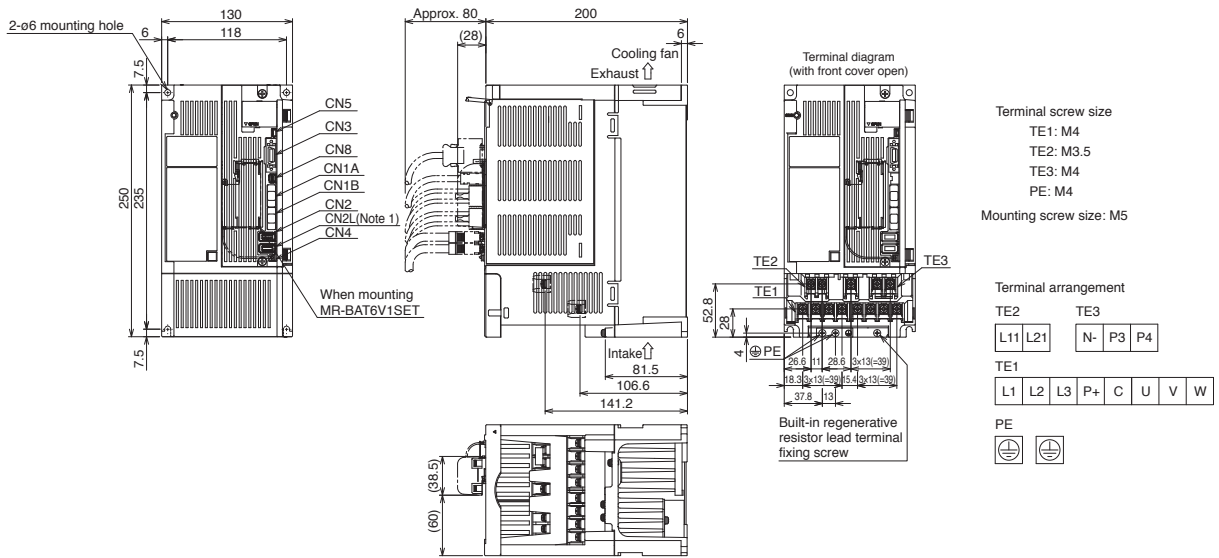

[Unit: mm]

● MR-J4-700B, MR-J4-700B-RJ, MR-J4-700B4, MR-J4-700B4-RJ

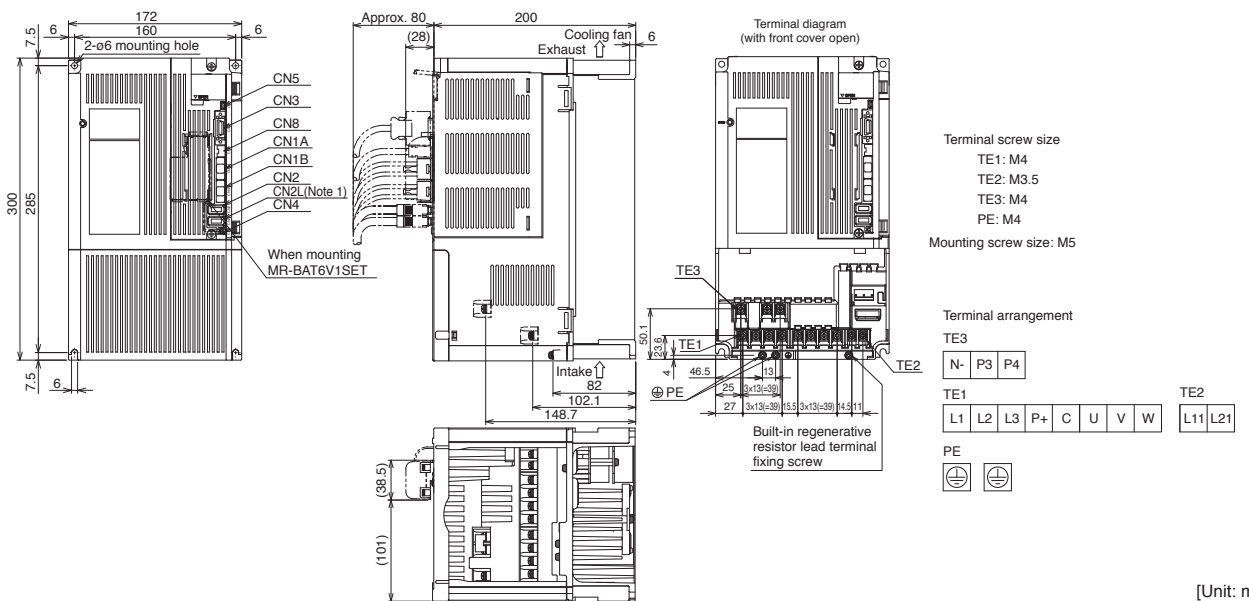

[Unit: mm]

Notes: 1. CN2L, CN7, and CN9 connectors are not available for MR-J4-B servo amplifier.

Servo Amplifiers

Rotary Servo Motors

Linear Servo Motors

Direct Drive Motors

Options/Peripheral Equipment

LVS/Wires

Product List

Precautions

# Servo Amplifiers

## MR-J4-B/MR-J4-B-RJ Dimensions

**B B-RJ**

- MR-J4-11KB, MR-J4-11KB-RJ, MR-J4-11KB4, MR-J4-11KB4-RJ
- MR-J4-15KB, MR-J4-15KB-RJ, MR-J4-15KB4, MR-J4-15KB4-RJ

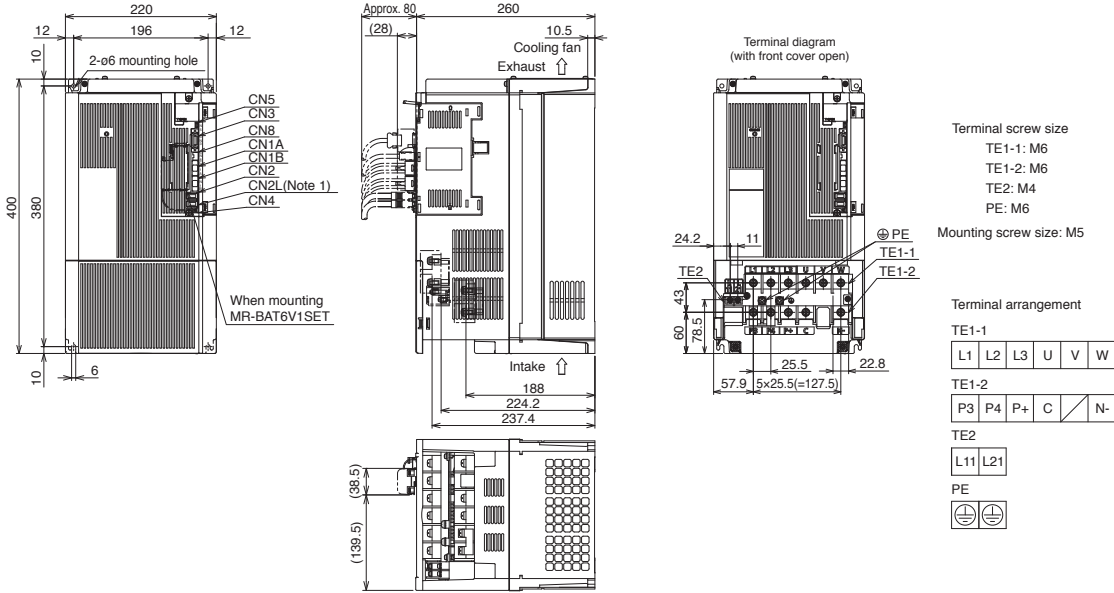

[Unit: mm]

- MR-J4-22KB, MR-J4-22KB-RJ, MR-J4-22KB4, MR-J4-22KB4-RJ

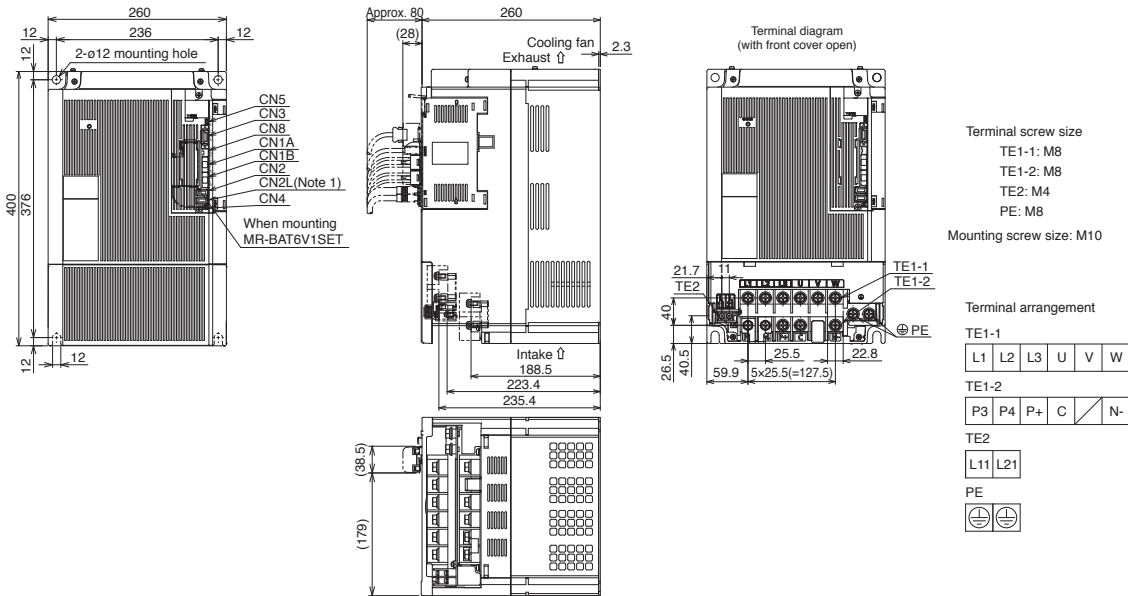

[Unit: mm]

Notes: 1. CN2L, CN7, and CN9 connectors are not available for MR-J4-B servo amplifier.

MR-J4-DU\_B/MR-J4-DU\_B-RJ Dimensions

- MR-J4-DU900B, MR-J4-DU900B-RJ, MR-J4-DU900B4, MR-J4-DU900B4-RJ
- MR-J4-DU11KB, MR-J4-DU11KB-RJ, MR-J4-DU11KB4, MR-J4-DU11KB4-RJ

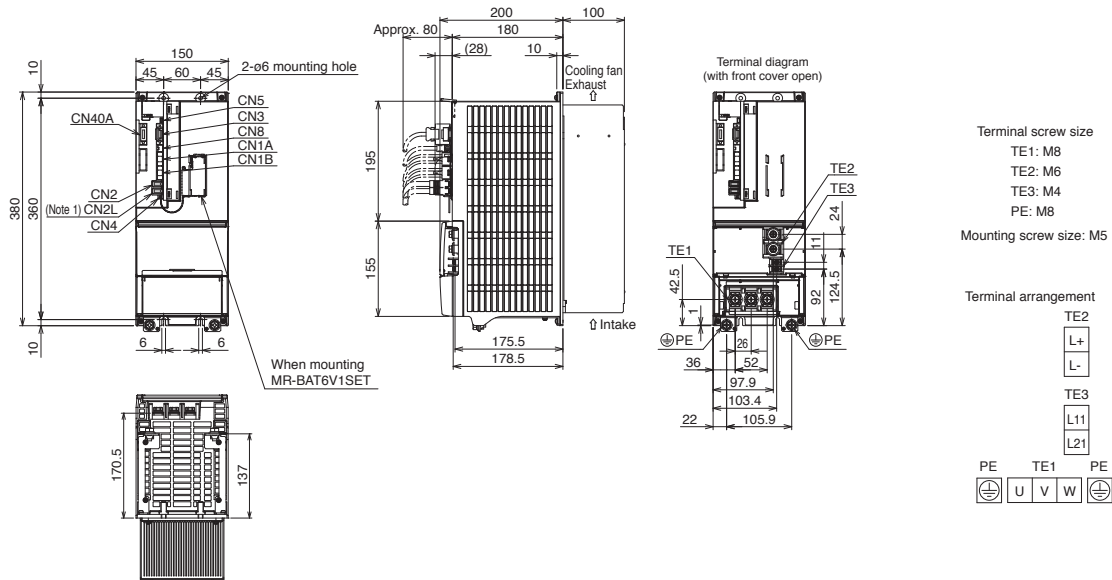

[Unit: mm]

- MR-J4-DU15KB, MR-J4-DU15KB-RJ, MR-J4-DU15KB4, MR-J4-DU15KB4-RJ
- MR-J4-DU22KB, MR-J4-DU22KB-RJ, MR-J4-DU22KB4, MR-J4-DU22KB4-RJ

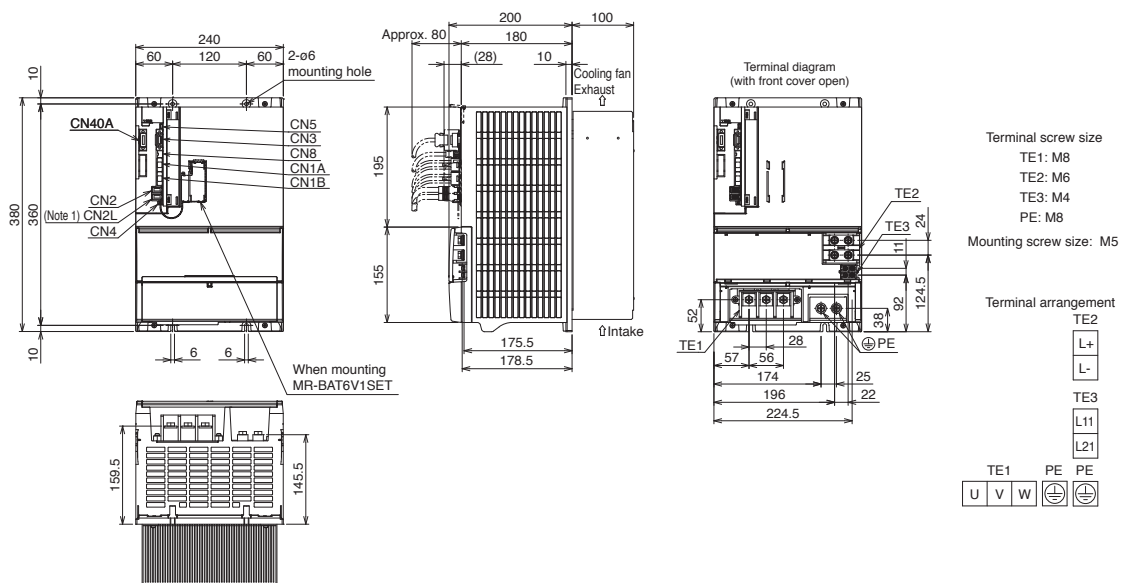

[Unit: mm]

Notes: 1. CN2L, CN7, and CN9 connectors are not available for MR-J4-DU\_B\_ drive unit.

# Servo Amplifiers

## MR-J4-DU\_B/MR-J4-DU\_B-RJ/MR-J4-DU\_B4-RJ100 Dimensions

**B** **B-RJ** **B-RJ100**

- MR-J4-DU30KB, MR-J4-DU30KB-RJ    ● MR-J4-DU37KB, MR-J4-DU37KB-RJ
- MR-J4-DU45KB4, MR-J4-DU45KB4-RJ, MR-J4-DU45KB4-RJ100
- MR-J4-DU55KB4, MR-J4-DU55KB4-RJ, MR-J4-DU55KB4-RJ100

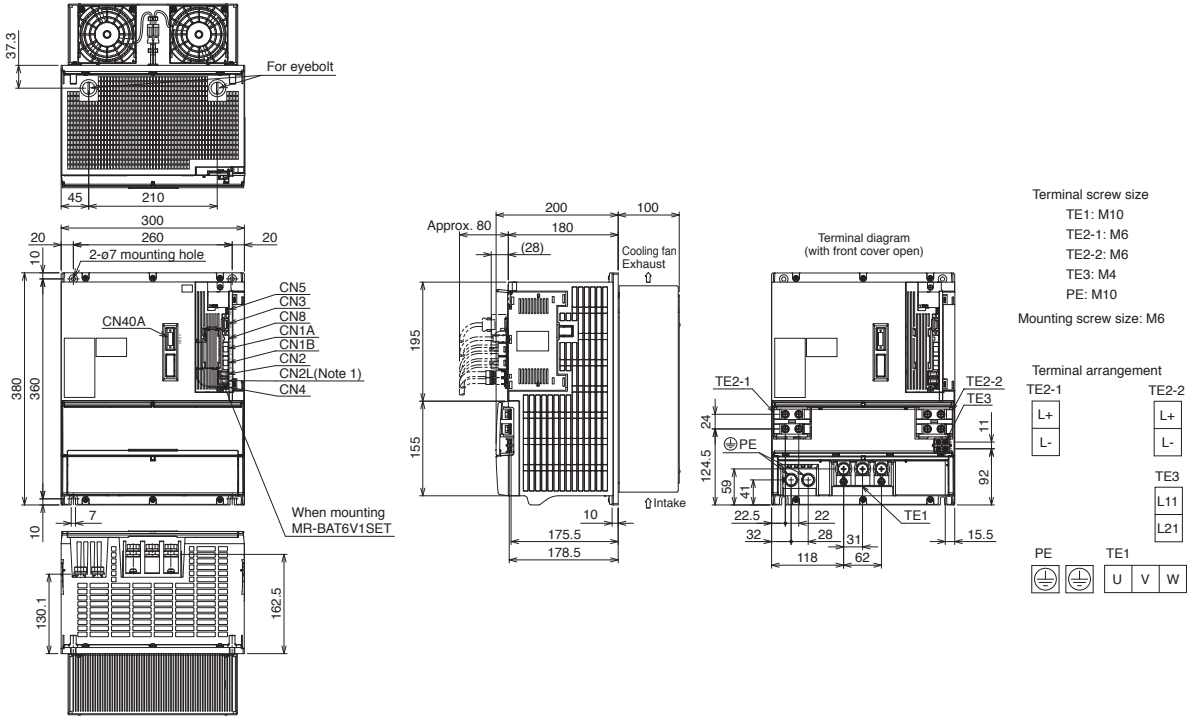

[Unit: mm]

- MR-J4-DU30KB4, MR-J4-DU30KB4-RJ    ● MR-J4-DU37KB4, MR-J4-DU37KB4-RJ

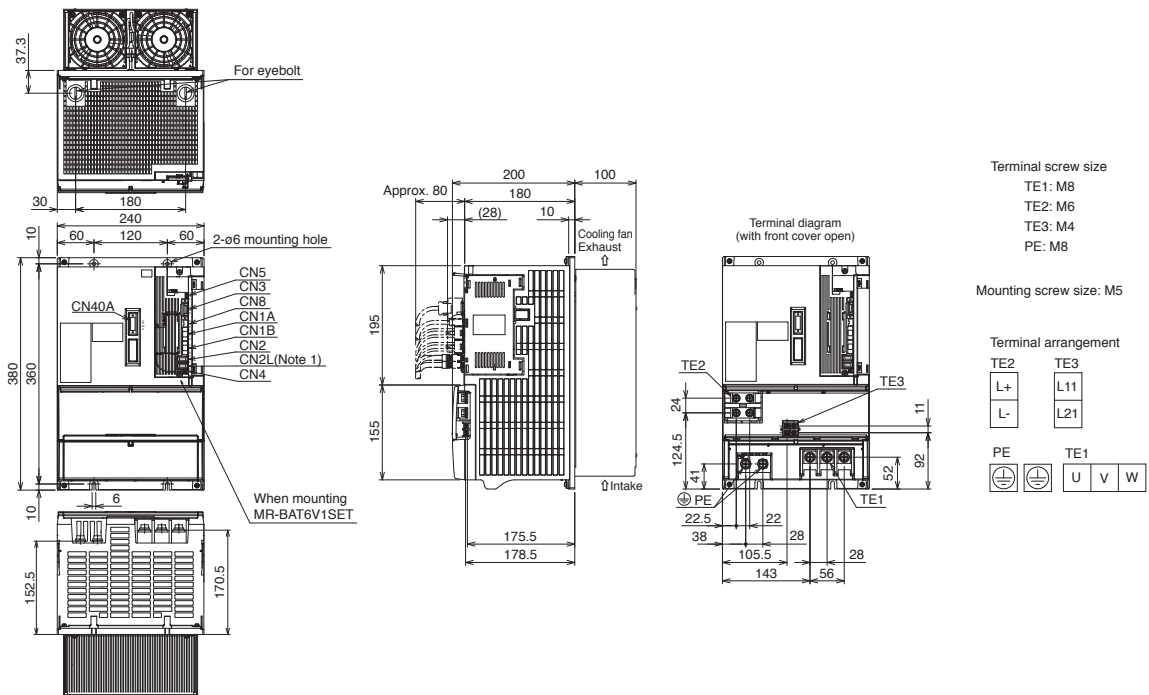

[Unit: mm]

Notes: 1. CN2L, CN7, and CN9 connectors are not available for MR-J4-DU\_B drive unit.

B B-RJ

MR-CV\_ Power Regeneration Converter Unit Dimensions

- MR-CV11K, MR-CV11K4
- MR-CV18K, MR-CV18K4

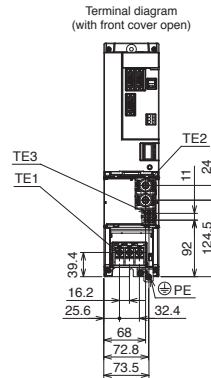
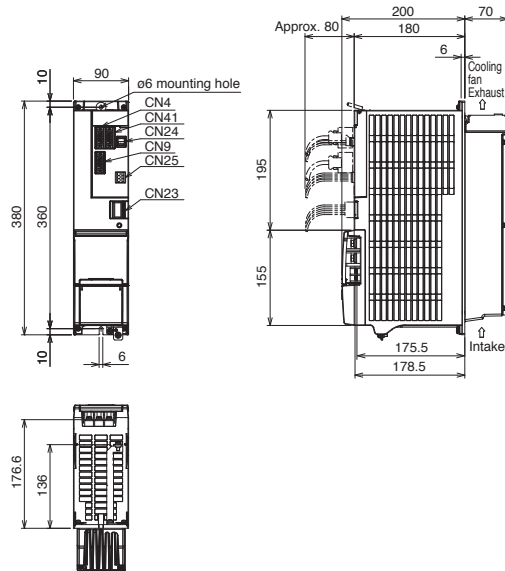

Terminal screw size  
 TE1: M5  
 TE2: M6  
 TE3: M4  
 PE: M5  
 Mounting screw size: M5

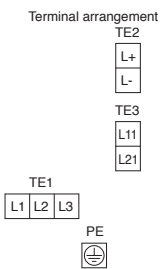

[Unit: mm]

- MR-CV30K, MR-CV30K4
- MR-CV37K, MR-CV37K4
- MR-CV45K, MR-CV45K4

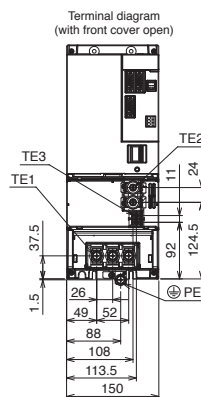
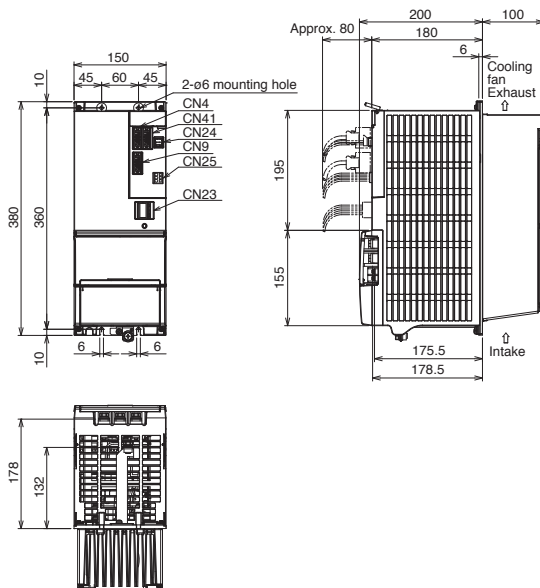

Terminal screw size  
 TE1: M8  
 TE2: M6  
 TE3: M4  
 PE: M8  
 Mounting screw size: M5

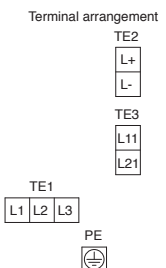

[Unit: mm]

Servo Amplifiers  
 Rotary Servo Motors  
 Linear Servo Motors  
 Direct Drive Motors  
 Options/Peripheral Equipment  
 LV5/Wires  
 Product List  
 Precautions

# Servo Amplifiers

## MR-CV\_ Power Regeneration Converter Unit Dimensions

**B** **B-RJ** **B-RJ100**

### ●MR-CV55K

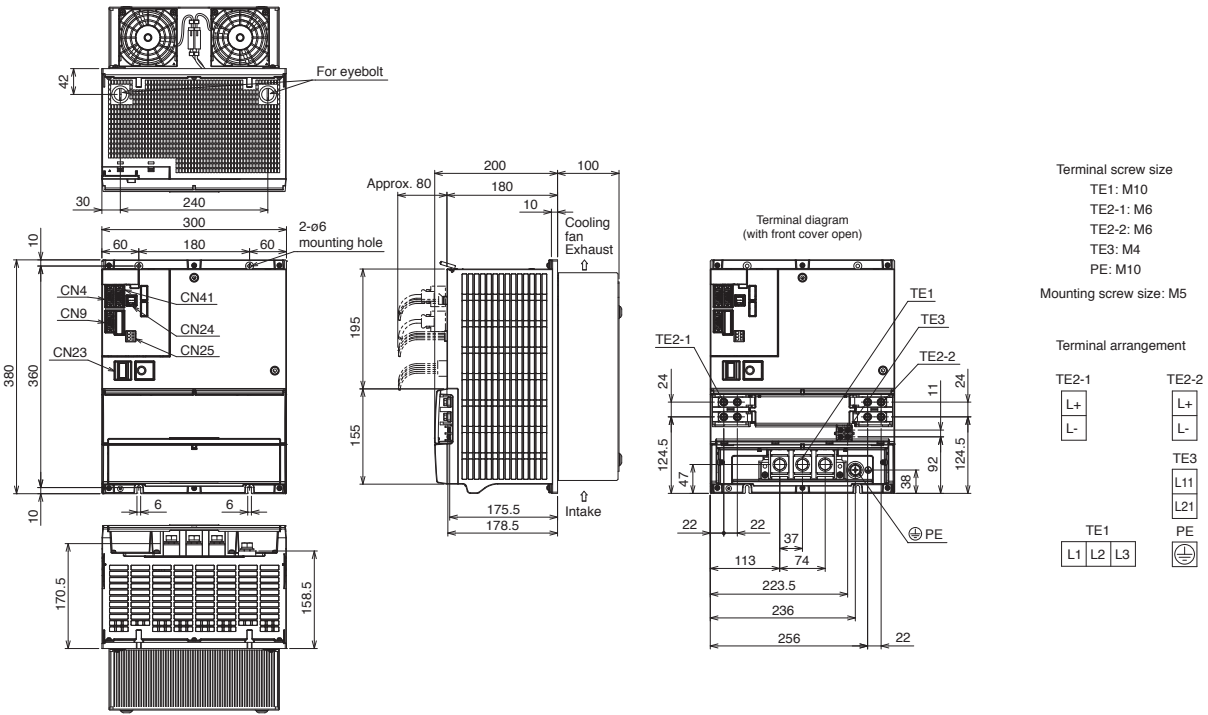

[Unit: mm]

### ●MR-CV55K4 ●MR-CV75K4

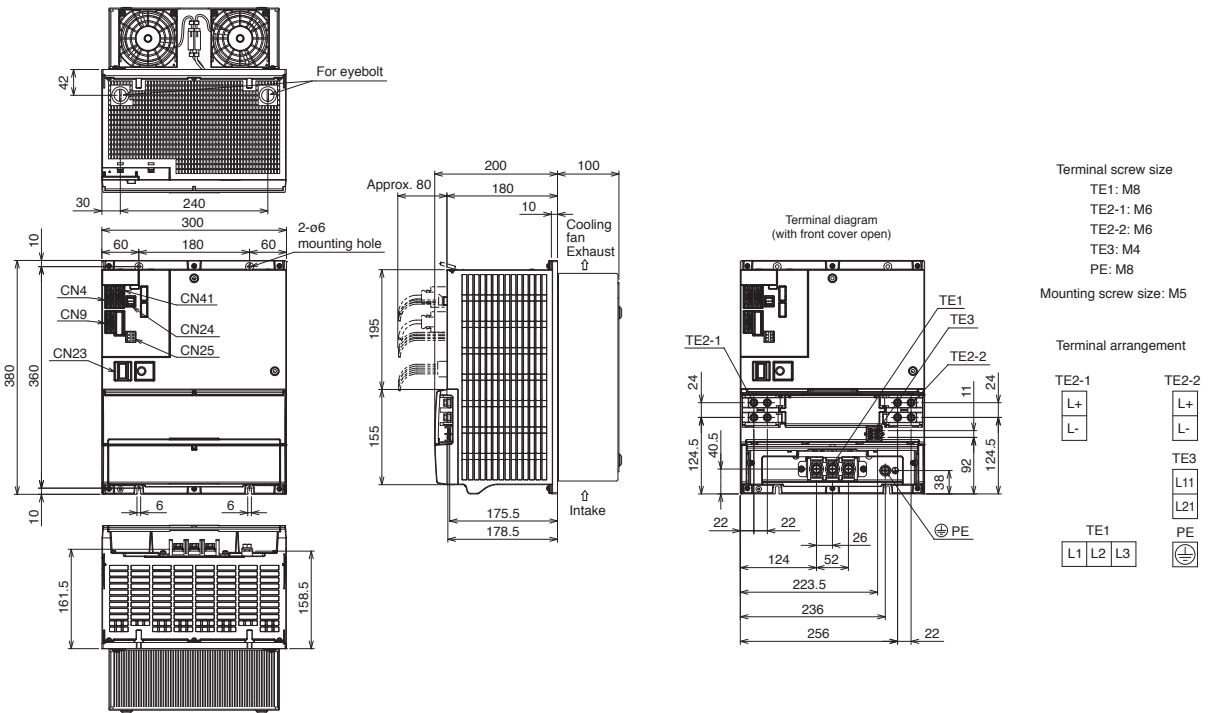

[Unit: mm]

Panel Cut Dimensions for Power Regeneration Converter Unit and Drive unit

B B-RJ B-RJ100

For MR-CV11K(4) and MR-CV18K(4)

For MR-CV30K(4), MR-CV37K(4), MR-CV45K(4),  
MR-CV55K(4), and MR-CV75K4

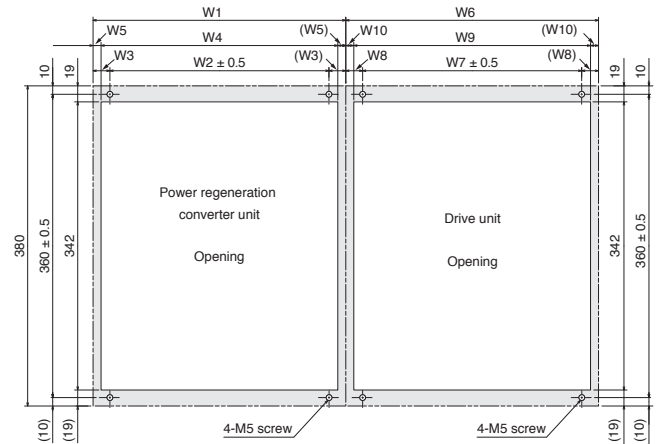
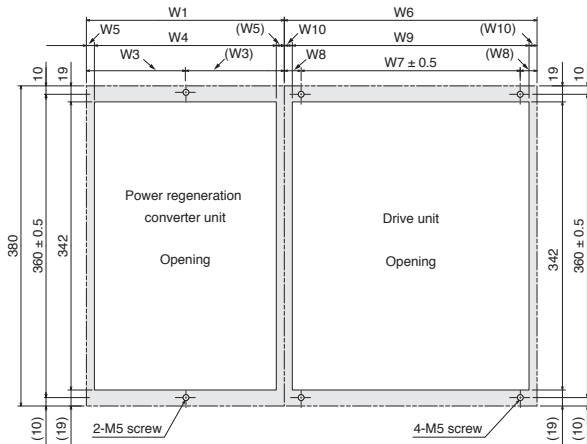

Power regeneration converter unit	Variable dimensions				
	W1	W2	W3	W4	W5
MR-CV11K(4), MR-CV18K(4)	90	-	45	82	4
MR-CV30K(4), MR-CV37K(4), MR-CV45K(4)	150	60	45	142	4
MR-CV55K(4), MR-CV75K4	300	180	60	282	9

Drive unit	Variable dimensions				
	W6	W7	W8	W9	W10
MR-J4-DU900B(4)(-RJ), MR-J4-DU11KB(4)(-RJ)	150	60	45	142	4
MR-J4-DU15KB(4)(-RJ), MR-J4-DU22KB(4)(-RJ)	240	120	60	222	9
MR-J4-DU30KB(-RJ), MR-J4-DU37KB(-RJ) MR-J4-DU45KB4(-RJ), MR-J4-DU45KB4-RJ100 MR-J4-DU55KB4(-RJ), MR-J4-DU55KB4-RJ100	300	260	20	281	9.5

[Unit: mm]

Servo Amplifiers

Rotary Servo Motors

Linear Servo Motors

Direct Drive Motors

Options/Peripheral Equipment

LVS/Wires

Product List

Precautions

# Servo Amplifiers

## MR-CR\_ Resistance Regeneration Converter Unit Dimensions

B B-RJ A A-RJ

●MR-CR55K, MR-CR55K4

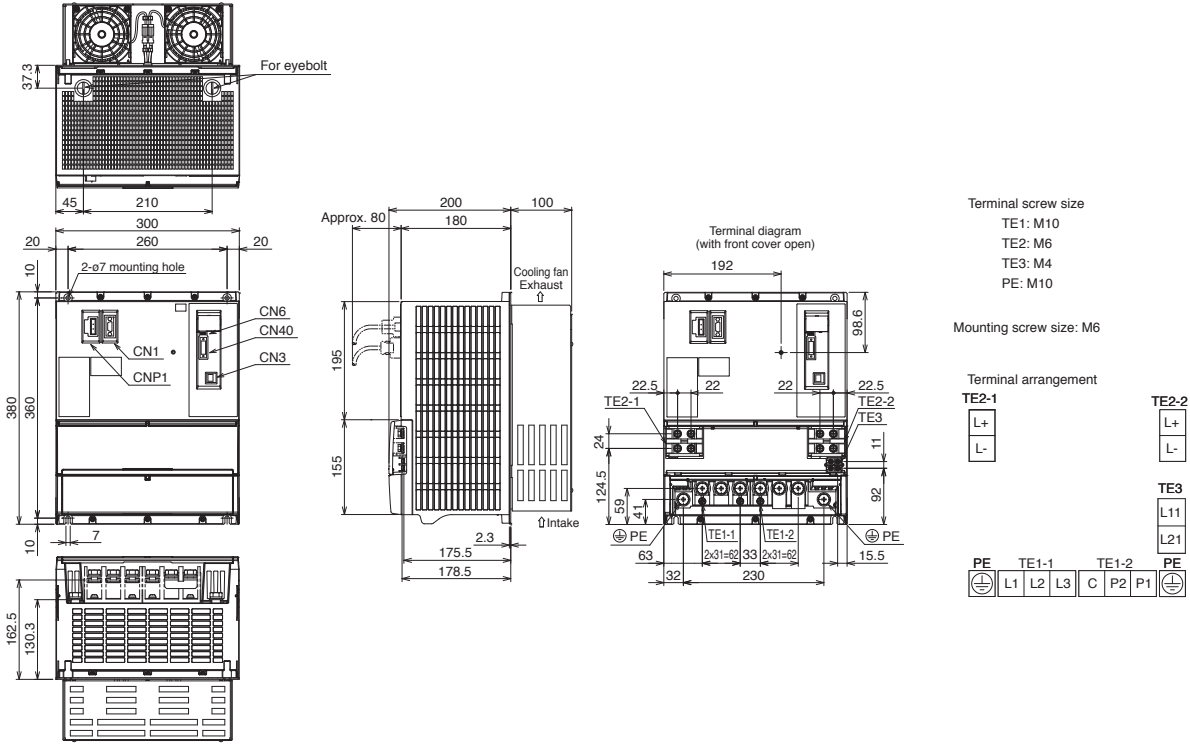

[Unit: mm]

## Panel Cut Dimensions for Resistance Regeneration Converter Unit and Drive Unit (Note 1)

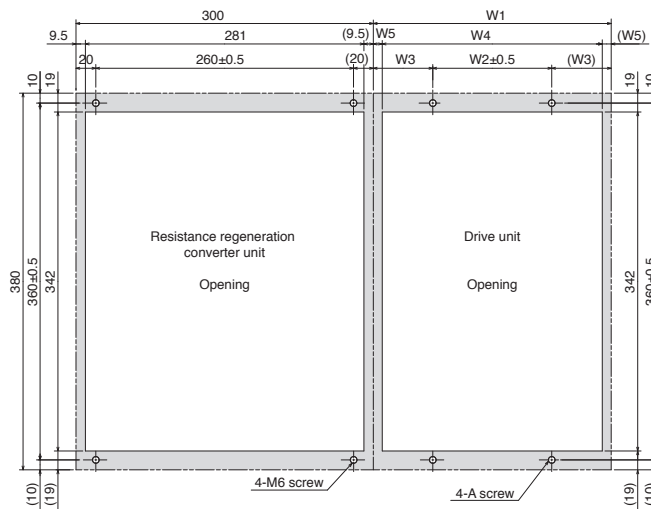

Drive unit model	Variable dimensions					Screw size
	W1	W2	W3	W4	W5	A
MR-J4-DU30KB, MR-J4-DU37KB, MR-J4-DU45KB4, MR-J4-DU55KB4 MR-J4-DU30KA, MR-J4-DU37KA, MR-J4-DU45KA4, MR-J4-DU55KA4	300	260	20	281	9.5	M6
MR-J4-DU30KB4, MR-J4-DU37KB4 MR-J4-DU30KA4, MR-J4-DU37KA4	240	120	60	222	9	M5

[Unit: mm]

Notes:1. The panel cut dimensions for resistance regeneration converter unit and drive unit are applicable for MR-J4-DU\_B\_/MR-J4-DU\_B\_-RJ/MR-J4-DU\_A\_/MR-J4-DU\_A\_-RJ.



**MR-J4W2-B/MR-J4W3-B Connections with Peripheral Equipment** (Note 1)

Peripheral equipment is connected to MR-J4W2-B/MR-J4W3-B as described below. Connectors, cables, options, and other necessary equipment are available so that users can set up the servo amplifier easily and start using it right away.

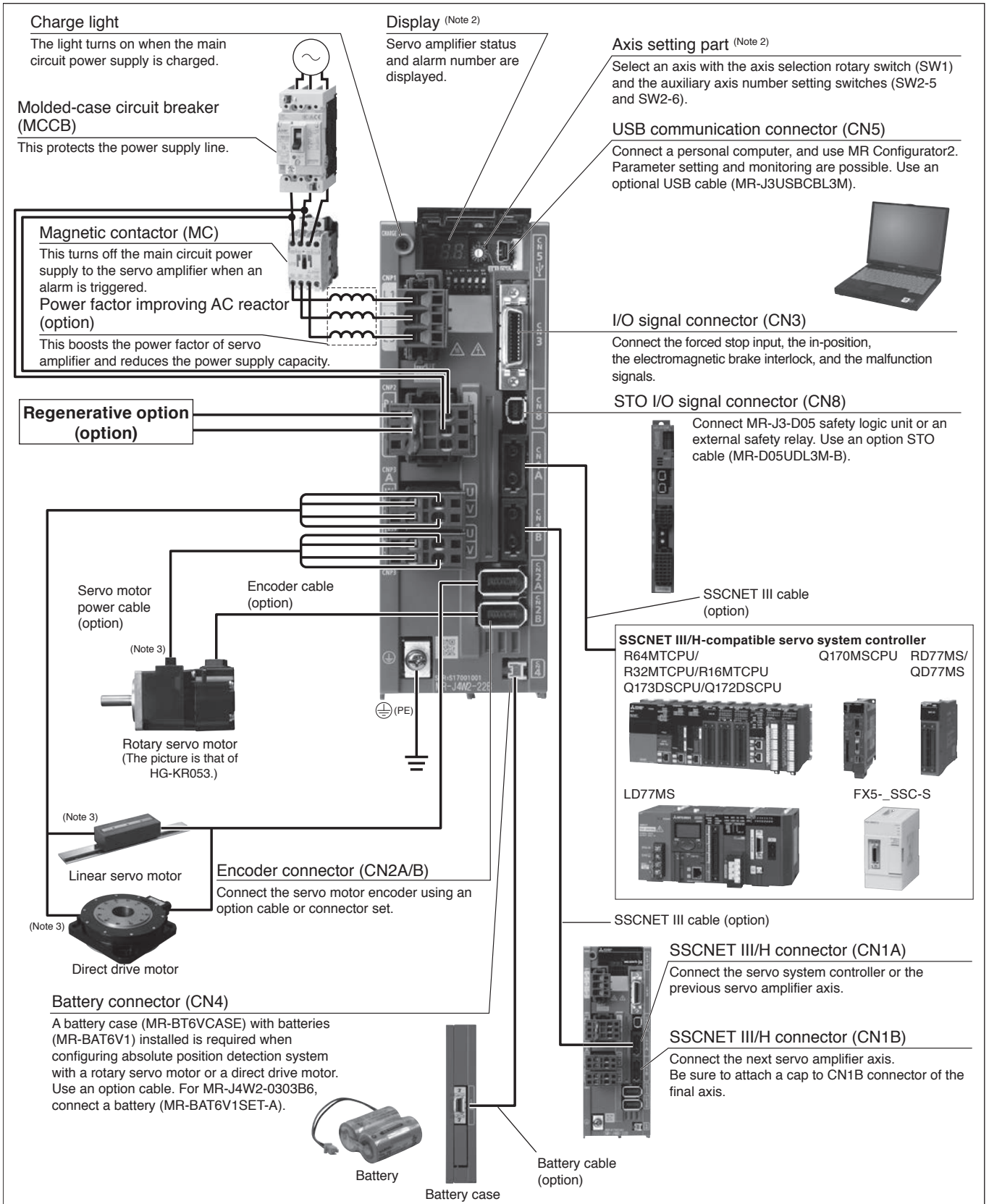

Notes: 1. The connection with the peripheral equipment is an example for MR-J4W2-22B. CNP3C and CN2C connectors are available for MR-J4W3-B servo amplifier. Refer to "MR-J4W2-\_B MR-J4W3-\_B MR-J4W2-0303B6 Servo Amplifier Instruction Manual" for the actual connections of the multi-axis servo amplifier.  
 2. This picture shows when the display cover is open.  
 3. Connect the grounding wire to the cabinet protective earth (PE) terminal via the servo amplifier for grounding the servo motor.

# Servo Amplifiers

## MR-J4W2-B (2-axis, SSCNET III/H Interface) Specifications

WB

Servo amplifier model MR-J4W2-		22B	44B	77B	1010B	
Output	Rated voltage	3-phase 170 V AC				
	Rated current (each axis) [A]	1.5	2.8	5.8	6.0	
Main circuit power supply input	Voltage/frequency <sup>(Note 1)</sup>	3-phase or 1-phase 200 V AC to 240 V AC, 50 Hz/60 Hz			3-phase 200 V AC to 240 V AC, 50 Hz/60 Hz	
	Rated current <sup>(Note 15)</sup> [A]	2.9 (5.0)	5.2 (9.0)	7.5 (13.0)	9.8	
	Permissible voltage fluctuation	3-phase or 1-phase 170 V AC to 264 V AC			3-phase 170 V AC to 264 V AC	
	Permissible frequency fluctuation	±5% maximum				
Control circuit power supply input	Voltage/frequency	1-phase 200 V AC to 240 V AC, 50 Hz/60 Hz				
	Rated current [A]	0.4				
	Permissible voltage fluctuation	1-phase 170 V AC to 264 V AC				
	Permissible frequency fluctuation	±5% maximum				
	Power consumption [W]	55				
Interface power supply		24 V DC ± 10% (required current capacity: 0.35 A (including CN8 connector signals))				
Control method		Sine-wave PWM control/current control method				
Capacitor regeneration	Reusable regenerative energy <sup>(Note 5)</sup> [J]	17	21	44		
	Moment of inertia (J) equivalent to permissible charging amount <sup>(Note 6)</sup> [× 10 <sup>-4</sup> kg·m <sup>2</sup> ]	3.45	4.26	8.92		
	Mass equivalent to permissible charging amount <sup>(Note 7)</sup> [kg]	LM-H3	3.8	4.7	9.8	
		LM-K2 LM-U2	8.5	10.5	22.0	
Permissible regenerative power of the built-in regenerative resistor <sup>(Note 2, 3)</sup> [W]		20		100		
Dynamic brake <sup>(Note 4)</sup>		Built-in				
SSCNET III/H command communication cycle <sup>(Note 13)</sup>		0.222 ms, 0.444 ms, 0.888 ms				
Communication function	USB	Connect a personal computer (MR Configurator2 compatible)				
Encoder output pulse		Compatible (A/B-phase pulse)				
Analog monitor		None				
Fully closed loop control <sup>(Note 12)</sup>		Available <sup>(Note 11)</sup>				
Load-side encoder interface <sup>(Note 9)</sup>		Mitsubishi Electric high-speed serial communication				
Servo functions		Advanced vibration suppression control II, adaptive filter II, robust filter, auto tuning, one-touch tuning, tough drive function, drive recorder function, tightening & press-fit control, machine diagnosis function, power monitoring function, scale measurement function <sup>(Note 14)</sup> , J3 compatibility mode				
Protective functions		Overcurrent shut-off, regenerative overvoltage shut-off, overload shut-off (electronic thermal), servo motor overheat protection, encoder error protection, regenerative error protection, undervoltage protection, instantaneous power failure protection, overspeed protection, error excessive protection, magnetic pole detection protection, linear servo control fault protection				

MR-J4W2-B (2-axis, SSCNET III/H Interface) Specifications

WB

Servo amplifier model MR-J4W2-		22B	44B	77B	1010B
Functional safety		STO (IEC/EN 61800-5-2) <sup>(Note 10)</sup>			
Safety performance	Satisfied standards <sup>(Note 17)</sup>	EN ISO 13849-1:2015 Category 3 PL e, IEC 61508 SIL 3, EN IEC 62061 maximum SIL 3, EN 61800-5-2			
	Response performance	8 ms or less (STO input OFF → energy shut-off)			
	Test pulse input (STO) <sup>(Note 8)</sup>	Test pulse interval: 1 Hz to 25 Hz, test pulse off time: 1 ms maximum			
	Mean time to dangerous failure (MTTFd)	MTTFd ≥ 100 [years] (314a)			
	Diagnostic coverage (DC)	DC = Medium, 97.6 [%]			
Probability of dangerous Failure per Hour (PFH)		PFH = 6.4 × 10 <sup>-9</sup> [1/h]			
Structure (IP rating)		Natural cooling, open (IP20)	Force cooling, open (IP20)		
Close mounting		Possible			
Environment	Ambient temperature	Operation: 0 °C to 55 °C (non-freezing), storage: -20 °C to 65 °C (non-freezing)			
	Ambient humidity	Operation/storage: 5 %RH to 90 %RH (non-condensing)			
	Ambience	Indoors (no direct sunlight); no corrosive gas, inflammable gas, oil mist or dust			
	Altitude	2000 m or less above sea level <sup>(Note 16)</sup>			
	Vibration resistance	5.9 m/s <sup>2</sup> at 10 Hz to 55 Hz (directions of X, Y and Z axes)			
Mass [kg]		1.5	1.5	2.0	2.0

- Notes: 1. Rated output and speed of a rotary servo motor and a direct drive motor; and continuous thrust and maximum speed of a linear servo motor are applicable when the servo amplifier is operated within the specified power supply voltage and frequency.
2. Select the most suitable regenerative option for your system with our drive system sizing software Motorizer.
3. Refer to "Regenerative Option" in this catalog for the permissible regenerative power [W] when a regenerative option is used.
4. When using the dynamic brake, refer to "MR-J4W2-\_B MR-J4W3-\_B MR-J4W2-0303B6 Servo Amplifier Instruction Manual" for the permissible load to motor inertia ratio and the permissible load to mass ratio.
5. Reusable regenerative energy is equivalent to the energy generated under the following conditions.  
 For rotary servo motor: the energy that is generated when the machine, whose moment of inertia is equivalent to the permissible charging amount, decelerates from the rated speed to a stop.  
 For linear servo motor: the energy that is generated when the machine, whose mass is equivalent to the permissible charging amount, decelerates from the maximum speed to a stop.  
 For direct drive motor: the energy that is generated when the machine, whose moment of inertia is equivalent to the permissible charging amount, decelerates from the rated speed to a stop.
6. This value is the moment of inertia when the rotary servo motor decelerates from the rated speed to a stop. When two axes are simultaneously decelerated, the permissible charging amount is equivalent to the total moments of inertia of the two axes. Otherwise, the permissible charging amount is equivalent to the moment of inertia of each axis. The value also applies to the direct drive motor.
7. This value is the mass when the linear servo motor decelerates from maximum speed to a stop. Mass of primary side (coil) is included. When two axes are simultaneously decelerated, the permissible charging amount is equivalent to the total masses of the two axes. Otherwise, the permissible charging amount is equivalent to the mass of each axis.
8. The test pulse is a signal for the external circuit to perform self-diagnosis by turning off the signals to the servo amplifier instantaneously at regular intervals.
9. Not compatible with pulse train interface (A/B/Z-phase differential output type).
10. STO is common for all axes.
11. The load-side encoder and the servo motor encoder are supported only in the two-wire type communication method.
12. Fully closed loop control is supported by the servo amplifiers with software version A3 or later.
13. The command communication cycle depends on the servo system controller specifications and the number of axes connected.
14. This function is supported by the servo amplifiers with software version A8 or later.
15. The value in brackets indicates the rated current when a 1-phase power supply input is used.
16. Refer to "MR-J4W2-\_B MR-J4W3-\_B MR-J4W2-0303B6 Servo Amplifier Instruction Manual" for the restrictions when using the servo amplifiers at altitude exceeding 1000 m and up to 2000 m above sea level.
17. The safety level depends on the setting value of [Pr. PF18 STO diagnosis error detection time] and whether or not STO input diagnosis is performed by TOFB output. Refer to "MR-J4W2-\_B MR-J4W3-\_B MR-J4W2-0303B6 Servo Amplifier Instruction Manual" for details.

Servo Amplifiers

Rotary Servo Motors

Linear Servo Motors

Direct Drive Motors

Options/Peripheral Equipment

LVS/Wires

Product List

Precautions

# Servo Amplifiers

## MR-J4W3-B (3-axis, SSCNET III/H Interface) Specifications

WB

Servo amplifier model MR-J4W3-		222B	444B	
Output	Rated voltage	3-phase 170 V AC		
	Rated current (each axis) [A]	1.5	2.8	
Main circuit power supply input	Voltage/frequency <sup>(Note 1)</sup>	3-phase or 1-phase 200 V AC to 240 V AC, 50 Hz/60 Hz		
	Rated current <sup>(Note 12)</sup> [A]	4.3 (7.5)	7.8 (13.5)	
	Permissible voltage fluctuation	3-phase or 1-phase 170 V AC to 264 V AC		
	Permissible frequency fluctuation	±5% maximum		
Control circuit power supply input	Voltage/frequency	1-phase 200 V AC to 240 V AC, 50 Hz/60 Hz		
	Rated current [A]	0.4		
	Permissible voltage fluctuation	1-phase 170 V AC to 264 V AC		
	Permissible frequency fluctuation	±5% maximum		
	Power consumption [W]	55		
Interface power supply		24 V DC ± 10% (required current capacity: 0.45 A (including CN8 connector signals))		
Control method		Sine-wave PWM control/current control method		
Capacitor regeneration	Reusable regenerative energy <sup>(Note 5)</sup> [J]	21	30	
	Moment of inertia (J) equivalent to permissible charging amount <sup>(Note 6)</sup> [ $\times 10^{-4}$ kg·m <sup>2</sup> ]	4.26	6.08	
	Mass equivalent to permissible charging amount <sup>(Note 7)</sup> [kg]	LM-H3	4.7	6.7
		LM-K2 LM-U2	10.5	15.0
Permissible regenerative power of the built-in regenerative resistor <sup>(Note 2, 3)</sup> [W]		30		
Dynamic brake <sup>(Note 4)</sup>		Built-in		
SSCNET III/H command communication cycle <sup>(Note 10)</sup>		0.222 ms <sup>(Note 11)</sup> , 0.444 ms, 0.888 ms		
Communication function	USB	Connect a personal computer (MR Configurator2 compatible)		
Encoder output pulse		Not compatible		
Analog monitor		None		
Fully closed loop control		Not available		
Servo functions		Advanced vibration suppression control II, adaptive filter II, robust filter, auto tuning, one-touch tuning, tough drive function, drive recorder function, tightening & press-fit control, machine diagnosis function, power monitoring function, J3 compatibility mode		
Protective functions		Overcurrent shut-off, regenerative overvoltage shut-off, overload shut-off (electronic thermal), servo motor overheat protection, encoder error protection, regenerative error protection, undervoltage protection, instantaneous power failure protection, overspeed protection, error excessive protection, magnetic pole detection protection, linear servo control fault protection		

MR-J4W3-B (3-axis, SSCNET III/H Interface) Specifications

WB

Servo amplifier model MR-J4W3-		222B	444B
Functional safety		STO (IEC/EN 61800-5-2) <sup>(Note 9)</sup>	
Safety performance	Satisfied standards <sup>(Note 14)</sup>	EN ISO 13849-1:2015 Category 3 PL e, IEC 61508 SIL 3, EN IEC 62061 maximum SIL 3, EN 61800-5-2	
	Response performance	8 ms or less (STO input OFF → energy shut-off)	
	Test pulse input (STO) <sup>(Note 8)</sup>	Test pulse interval: 1 Hz to 25 Hz, test pulse off time: 1 ms maximum	
	Mean time to dangerous failure (MTTFd)	MTTFd ≥ 100 [years] (314a)	
	Diagnostic coverage (DC)	DC = Medium, 97.6 [%]	
	Probability of dangerous Failure per Hour (PFH)	PFH = 6.4 × 10 <sup>-9</sup> [1/h]	
Structure (IP rating)		Force cooling, open (IP20)	
Close mounting		Possible	
Environment	Ambient temperature	Operation: 0 °C to 55 °C (non-freezing), storage: -20 °C to 65 °C (non-freezing)	
	Ambient humidity	Operation/storage: 5 %RH to 90 %RH (non-condensing)	
	Ambience	Indoors (no direct sunlight); no corrosive gas, inflammable gas, oil mist or dust	
	Altitude	2000 m or less above sea level <sup>(Note 13)</sup>	
	Vibration resistance	5.9 m/s <sup>2</sup> at 10 Hz to 55 Hz (directions of X, Y and Z axes)	
Mass [kg]		1.9	1.9

- Notes: 1. Rated output and speed of a rotary servo motor and a direct drive motor; and continuous thrust and maximum speed of a linear servo motor are applicable when the servo amplifier is operated within the specified power supply voltage and frequency.
2. Select the most suitable regenerative option for your system with our drive system sizing software Motorizer.
3. Refer to "Regenerative Option" in this catalog for the permissible regenerative power [W] when a regenerative option is used.
4. When using the dynamic brake, refer to "MR-J4W2-\_B MR-J4W3-\_B MR-J4W2-0303B6 Servo Amplifier Instruction Manual" for the permissible load to motor inertia ratio and the permissible load to mass ratio.
5. Reusable regenerative energy is equivalent to the energy generated under the following conditions.  
 For rotary servo motor: the energy that is generated when the machine, whose moment of inertia is equivalent to the permissible charging amount, decelerates from the rated speed to a stop.  
 For linear servo motor: the energy that is generated when the machine, whose mass is equivalent to the permissible charging amount, decelerates from the maximum speed to a stop.  
 For direct drive motor: the energy that is generated when the machine, whose moment of inertia is equivalent to the permissible charging amount, decelerates from the rated speed to a stop.
6. This value is the moment of inertia when the rotary servo motor decelerates from the rated speed to a stop. When three axes are simultaneously decelerated, the permissible charging amount is equivalent to the total moments of inertia of the three axes. Otherwise, the permissible charging amount is equivalent to the moment of inertia of each axis. The value also applies to the direct drive motor.
7. This value is the mass when the linear servo motor decelerates from maximum speed to a stop. Mass of primary side (coil) is included. When three axes are simultaneously decelerated, the permissible charging amount is equivalent to the total masses of the three axes. Otherwise, the permissible charging amount is equivalent to the mass of each axis.
8. The test pulse is a signal for the external circuit to perform self-diagnosis by turning off the signals to the servo amplifier instantaneously at regular intervals.
9. STO is common for all axes.
10. The command communication cycle depends on the servo system controller specifications and the number of axes connected.
11. Servo amplifier with software version A3 or later is compatible with the command communication cycle of 0.222 ms. However, note that the following functions are not available when 0.222 ms is used: auto tuning (real time, one-touch, and vibration suppression control), adaptive filter II, vibration tough drive, and power monitoring.
12. The value in brackets indicates the rated current when a 1-phase power supply input is used.
13. Refer to "MR-J4W2-\_B MR-J4W3-\_B MR-J4W2-0303B6 Servo Amplifier Instruction Manual" for the restrictions when using the servo amplifiers at altitude exceeding 1000 m and up to 2000 m above sea level.
14. The safety level depends on the setting value of [Pr. PF18 STO diagnosis error detection time] and whether or not STO input diagnosis is performed by TOFB output. Refer to "MR-J4W2-\_B MR-J4W3-\_B MR-J4W2-0303B6 Servo Amplifier Instruction Manual" for details.

Servo Amplifiers

Rotary Servo Motors

Linear Servo Motors

Direct Drive Motors

Options/Peripheral Equipment

LVS/Wires

Product List

Precautions

## MR-J4W2-0303B6 (2-axis, SSCNET III/H Interface) Specifications

WB

Servo amplifier model		MR-J4W2-0303B6
Output	Rated voltage	3-phase 13 V AC
	Rated current (each axis) [A]	2.4
Main circuit power supply input	Voltage <sup>(Note 1)</sup>	48 V DC/24 V DC <sup>(Note 4)</sup>
	Rated current [A]	For 48 V DC: 2.4 A For 24 V DC: 4.8 A
	Permissible voltage fluctuation	For 48 V DC: 40.8 V DC to 55.2 V DC For 24 V DC: 21.6 V DC to 26.4 V DC
Control circuit power supply input	Voltage	24 V DC
	Rated current [A]	0.5
	Permissible voltage fluctuation	21.6 V DC to 26.4 V DC
	Power consumption [W]	10
Interface power supply		24 V DC ± 10% (required current capacity: 0.25 A)
Control method		Sine-wave PWM control/current control method
Capacitor regeneration	Reusable regenerative energy <sup>(Note 2)</sup> [J]	0.9
	Moment of inertia (J) equivalent to permissible charging amount <sup>(Note 3)</sup> [ $\times 10^{-4}$ kg·m <sup>2</sup> ]	0.18
Permissible regenerative power of the built-in regenerative resistor [W]		1.3
Dynamic brake <sup>(Note 6)</sup>		Built-in <sup>(Note 5)</sup>
SSCNET III/H command communication cycle <sup>(Note 8)</sup>		0.222 ms, 0.444 ms, 0.888 ms
Communication function	USB	Connect a personal computer (MR Configurator2 compatible)
Encoder output pulse		Compatible (A/B-phase pulse)
Analog monitor		2 channels
Fully closed loop control		Not compatible
Servo functions		Advanced vibration suppression control II, adaptive filter II, robust filter, auto tuning, one-touch tuning, vibration tough drive function, drive recorder function, tightening & press-fit control, machine diagnosis function, power monitoring function, J3 compatibility mode
Protective functions		Overcurrent shut-off, regenerative overvoltage shut-off, overload shut-off (electronic thermal), servo motor overheat protection, encoder error protection, regenerative error protection, undervoltage protection, instantaneous power failure protection, overspeed protection, error excessive protection
Structure (IP rating)		Natural cooling, open (IP20)
Close mounting		Possible <sup>(Note 7)</sup>
DIN rail mounting (35 mm wide)		Possible
Environment	Ambient temperature	Operation: 0 °C to 55 °C (non-freezing), storage: -20 °C to 65 °C (non-freezing)
	Ambient humidity	Operation/storage: 5 %RH to 90 %RH (non-condensing)
	Ambience	Indoors (no direct sunlight); no corrosive gas, inflammable gas, oil mist or dust
	Altitude	1000 m or less above sea level
Vibration resistance		5.9 m/s <sup>2</sup> at 10 Hz to 55 Hz (directions of X, Y and Z axes)
Mass [kg]		0.3

- Notes: 1. Rated output and speed of a rotary servo motor are applicable when the servo amplifier is operated within the specified power supply voltage.  
2. Reusable regenerative energy is equivalent to the energy that is generated when the machine, whose moment of inertia is equivalent to the permissible charging amount, decelerates from the rated speed to a stop.  
3. This value is the moment of inertia when the rotary servo motor decelerates from the rated speed to a stop. When two axes are simultaneously decelerated, the permissible charging amount is equivalent to the total moments of inertia of the two axes. Otherwise, the permissible charging amount is equivalent to the moment of inertia of each axis.  
4. Initial value is 48 V DC. For 24 V DC, set [Pr. PC05] to "\_ 1 \_ \_". Servo motor characteristics vary depending on whether the voltage is 48 V DC or 24 V DC. Refer to "HG-AK Series (Ultra-Compact Size, Ultra-Small Capacity) Specifications" and "HG-AK Series Torque Characteristics" in this catalog.  
5. The dynamic brake is electronic. The electronic dynamic brake does not operate when the control circuit power is off. It may not operate depending on alarms and warnings. Refer to "MR-J4W2- \_B MR-J4W3- \_B MR-J4W2-0303B6 Servo Amplifier Instruction Manual" for details.  
6. When using the dynamic brake, refer to "MR-J4W2- \_B MR-J4W3- \_B MR-J4W2-0303B6 Servo Amplifier Instruction Manual" for the permissible load to motor inertia ratio.  
7. When the servo amplifiers are closely mounted, keep the ambient temperature at 45 °C or lower, or keep the total load of the two axes at 45 W or lower.  
8. The command communication cycle depends on the servo system controller specifications and the number of axes connected.

MR-J4W2-B Standard Wiring Diagram Example (Note 13)

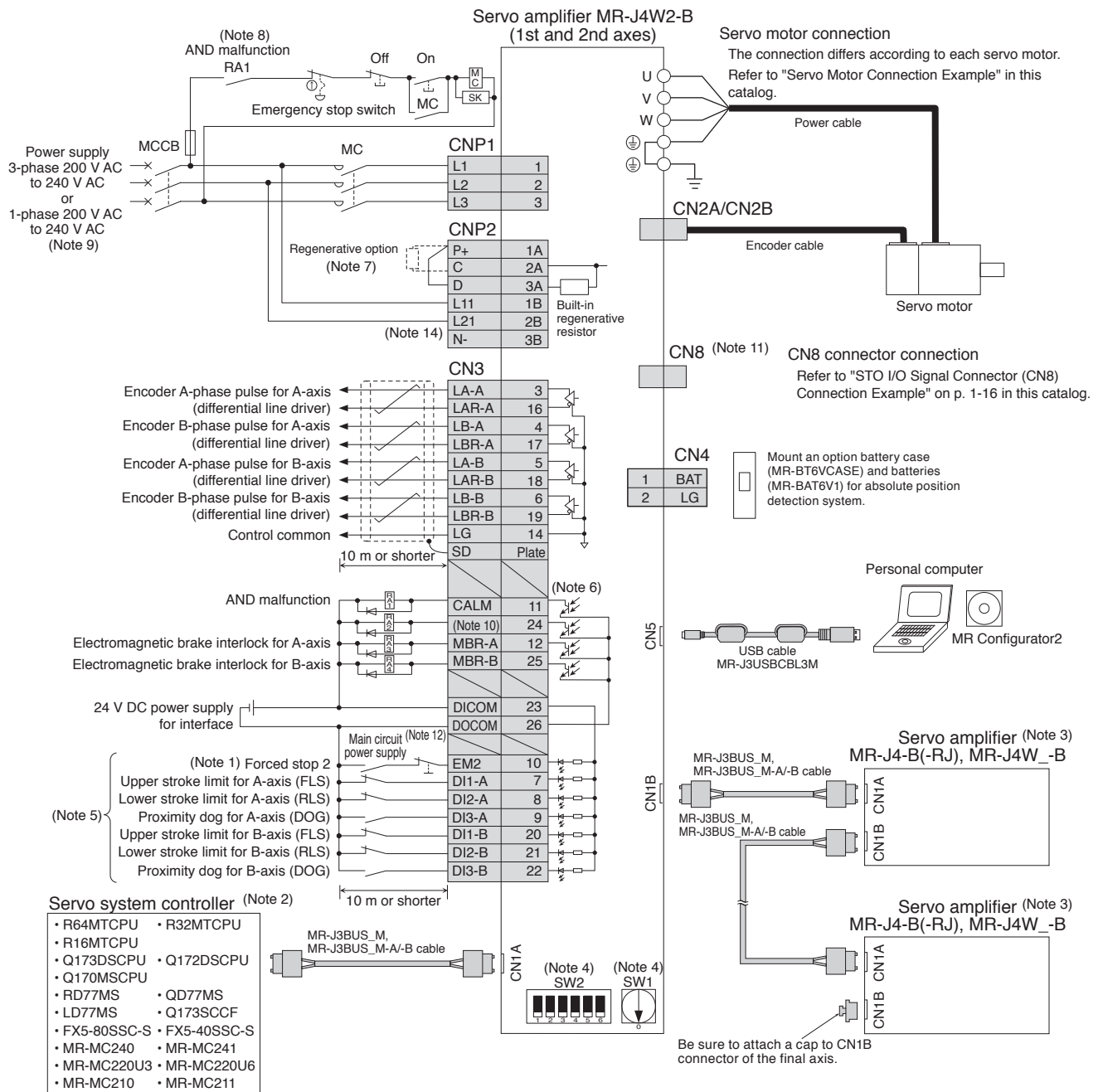

- Notes:
- The forced stop signal is issued for two axes of the servo amplifier. For overall system, apply the emergency stop on the servo system controller side.
  - For details such as setting the servo system controllers, refer to the programming or user's manual of each controller.
  - Connections for the third and following axes are omitted.
  - Up to 64 axes are set with a combination of an axis selection rotary switch (SW1) and auxiliary axis number setting switches (SW2-5 and SW2-6). Note that the number of the connectable axes depends on the servo system controller specifications.
  - Devices can be assigned to DI1-A/B, DI2-A/B and DI3-A/B with the servo system controller setting. Refer to the controller instruction manuals for details on setting.
  - This is for sink wiring. Source wiring is also possible.
  - When not using a regenerative option, connect a short-circuit bar between P+ and D to use the built-in regenerative resistor. When using a regenerative option, disconnect the short-circuit bar between P+ and D, and then connect the regenerative option to P+ and C.
  - Select either of the following functions for CALM (AND malfunction) with the servo system controller.
    - The contact opens when an alarm occurs on one of the axes.
    - The contact opens when an alarm occurs on all axes.
  - For 1-phase 200 V AC to 240 V AC, connect the power supply to L1 and L3 terminals. Do not connect anything to L2. The connections are different from MR-J3W-B series servo amplifiers. Be careful not to make a connection error when replacing MR-J3W-B with MR-J4W2-B. Refer to "MR-J4W2-B (2-axis, SSCNET III/H Interface) Specifications" in this catalog for power supply specifications.
  - CINP (AND in-position) is assigned to this pin as default. Device for this pin can be changed with [Pr. PD08].
  - Be sure to attach a short-circuit connector supplied with the servo amplifier when the STO function is not used.
  - To prevent an unexpected restart of the servo amplifier, create a circuit to turn off EM2 (Forced stop 2) when the main circuit power is turned off.
  - To turn on/off the main circuit power supply by a DC power supply, refer to "MR-J4W2-B MR-J4W3-B MR-J4W2-0303B6 Servo Amplifier Instruction Manual" for a connection example of the power supply circuit.
  - Do not ground the servo amplifier between L11 and L21 even when the control circuit power supply is separated from the main circuit power supply using an uninterruptible power supply (UPS) or an isolation transformer.

**!** Be sure to read through Instruction Manual for the actual wiring and use. Use the equipment after you have a full knowledge of the equipment, safety information and instructions.

Servo Amplifiers  
Rotary Servo Motors  
Linear Servo Motors  
Direct Drive Motors  
Options/Peripheral Equipment  
LV5/Wires  
Product List  
Precautions

## MR-J4W3-B Standard Wiring Diagram Example (Note 13)

WB

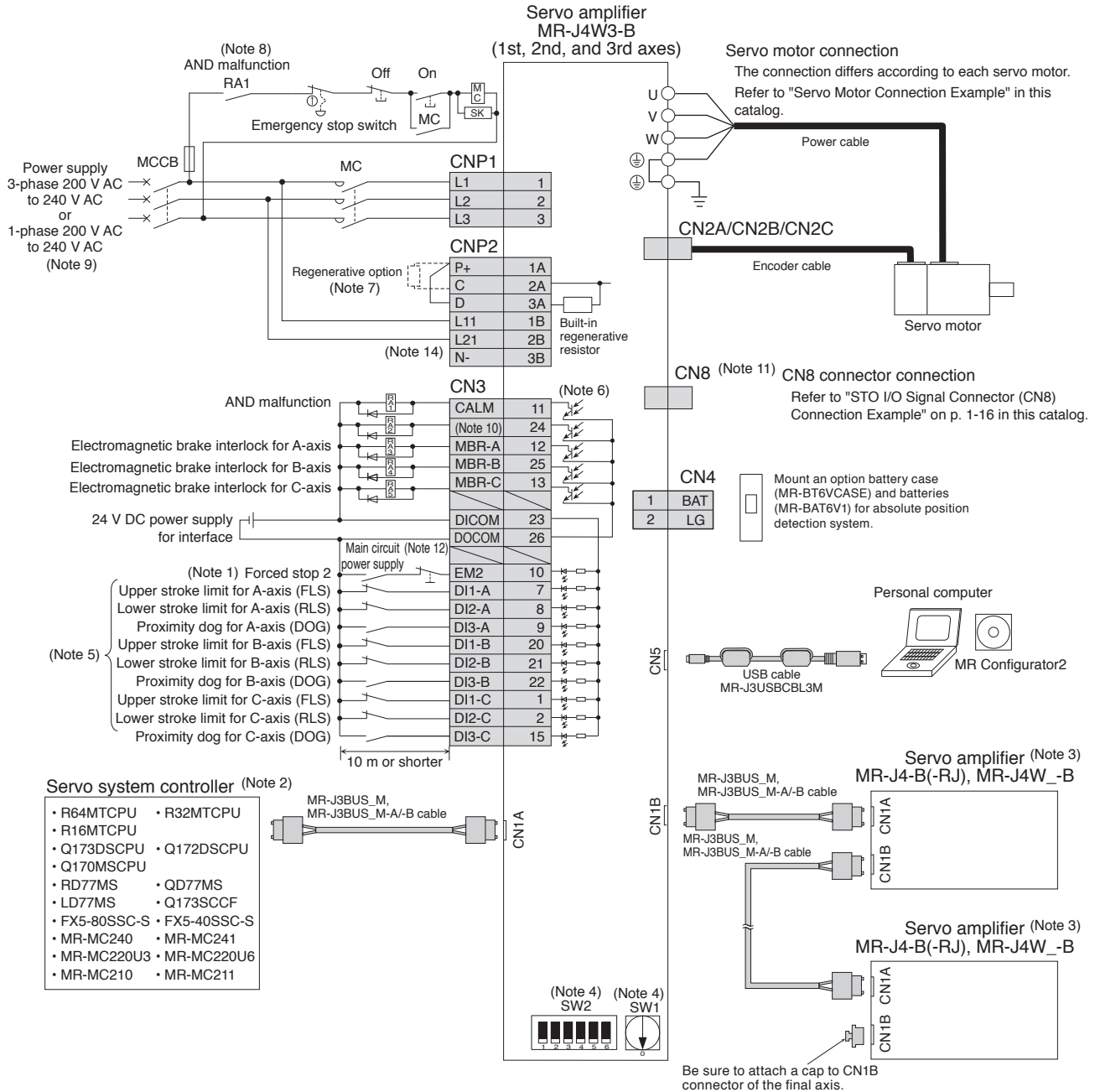

- Notes:
- The forced stop signal is issued for three axes of the servo amplifier. For overall system, apply the emergency stop on the servo system controller side.
  - For details such as setting the servo system controllers, refer to the programming or user's manual of each controller.
  - Connections for the fourth and following axes are omitted.
  - Up to 64 axes are set with a combination of an axis selection rotary switch (SW1) and auxiliary axis number setting switches (SW2-5 and SW2-6). Note that the number of the connectable axes depends on the servo system controller specifications.
  - Devices can be assigned to DI1-A/B/C, DI2-A/B/C and DI3-A/B/C with the servo system controller setting. Refer to the controller instruction manuals for details on setting.
  - This is for sink wiring. Source wiring is also possible.
  - When not using a regenerative option, connect a short-circuit bar between P+ and D to use the built-in regenerative resistor. When using a regenerative option, disconnect the short-circuit bar between P+ and D, and then connect the regenerative option to P+ and C.
  - Select either of the following functions for CALM (AND malfunction) with the servo system controller.
    - The contact opens when an alarm occurs on one of the axes.
    - The contact opens when an alarm occurs on all axes.
  - For 1-phase 200 V AC to 240 V AC, connect the power supply to L1 and L3 terminals. Do not connect anything to L2. Refer to "MR-J4W3-B (3-axis, SSCNET III/H Interface) Specifications" in this catalog for power supply specifications.
  - CINP (AND in-position) is assigned to this pin as default. Device for this pin can be changed with [Pr. PD08].
  - Be sure to attach a short-circuit connector supplied with the servo amplifier when the STO function is not used.
  - To prevent an unexpected restart of the servo amplifier, create a circuit to turn off EM2 (Forced stop 2) when the main circuit power is turned off.
  - To turn on/off the main circuit power supply by a DC power supply, refer to "MR-J4W2-\_B MR-J4W3-\_B MR-J4W2-0303B6 Servo Amplifier Instruction Manual" for a connection example of the power supply circuit.
  - Do not ground the servo amplifier between L11 and L21 even when the control circuit power supply is separated from the main circuit power supply using an uninterruptible power supply (UPS) or an isolation transformer.



Be sure to read through Instruction Manual for the actual wiring and use. Use the equipment after you have a full knowledge of the equipment, safety information and instructions.



### Servo Motor Connection Example (Rotary Servo Motor) Semi-Closed Loop Control System with MR-J4W2-B/MR-J4W3-B

● For HG-KR/HG-MR series

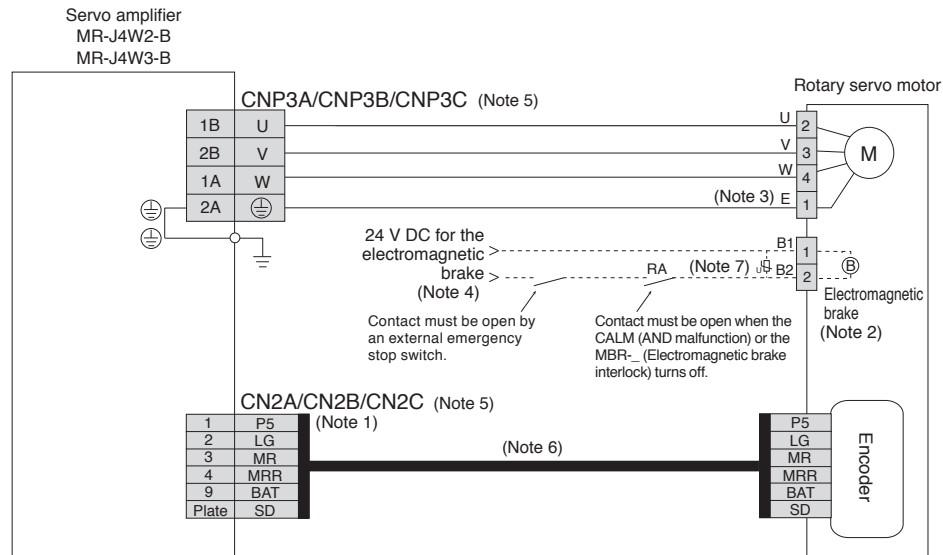

● For HG-SR series

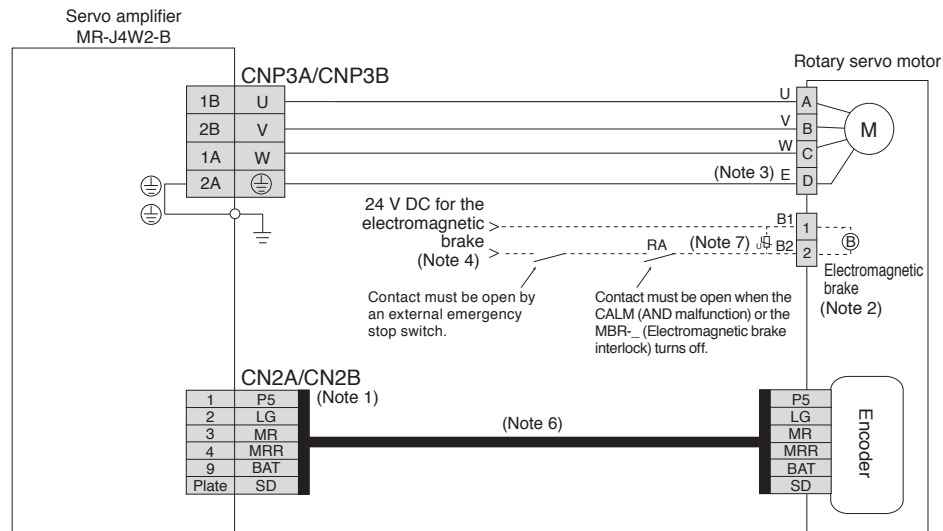

- Notes: 1. The signals shown are applicable when using a two-wire type encoder cable. Four-wire type is also compatible.  
 2. This is for the servo motor with electromagnetic brake. The electromagnetic brake terminals (B1, B2) do not have polarity.  
 3. Connect the grounding wire to the cabinet protective earth (PE) terminal via the servo amplifier for grounding the servo motor.  
 4. Do not use the 24 V DC interface power supply for the electromagnetic brake. Provide a dedicated power supply to the electromagnetic brake.  
 5. CNP3C and CN2C connectors are available for MR-J4W3-B servo amplifier.  
 6. Encoder cable is available as an option. Refer to "Servo Motor Instruction Manual (Vol. 3)" when fabricating the cables.  
 7. Be sure to install a surge absorber between B1 and B2.



Be sure to read through Instruction Manual for the actual wiring and use. Use the equipment after you have a full knowledge of the equipment, safety information and instructions.

## Servo Motor Connection Example (Rotary Servo Motor) Semi-Closed Loop Control System with MR-J4W2-B

● For HG-UR series

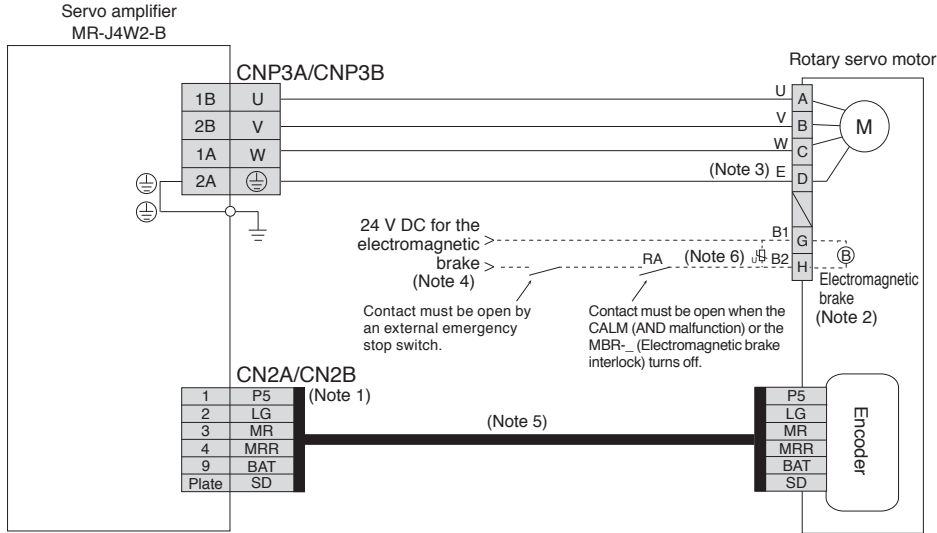

- Notes: 1. The signals shown are applicable when using a two-wire type encoder cable. Four-wire type is also compatible.  
 2. This is for the servo motor with electromagnetic brake. The electromagnetic brake terminals (B1, B2) do not have polarity.  
 3. Connect the grounding wire to the cabinet protective earth (PE) terminal via the servo amplifier for grounding the servo motor.  
 4. Do not use the 24 V DC interface power supply for the electromagnetic brake. Provide a dedicated power supply to the electromagnetic brake.  
 5. Encoder cable is available as an option. Refer to "Servo Motor Instruction Manual (Vol. 3)" when fabricating the cables.  
 6. Be sure to install a surge absorber between B1 and B2.



Be sure to read through Instruction Manual for the actual wiring and use. Use the equipment after you have a full knowledge of the equipment, safety information and instructions.

## Servo Motor Connection Example (Rotary Servo Motor) Fully Closed Loop Control System with MR-J4W2-B

● For HG-KR/HG-MR series

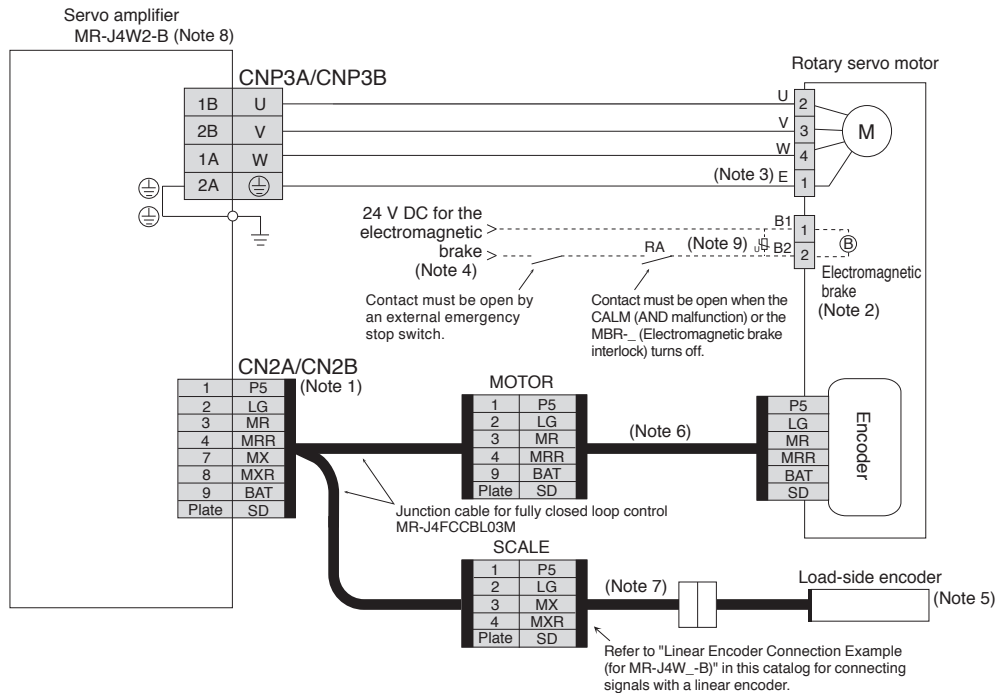

● For HG-SR/HG-JR series

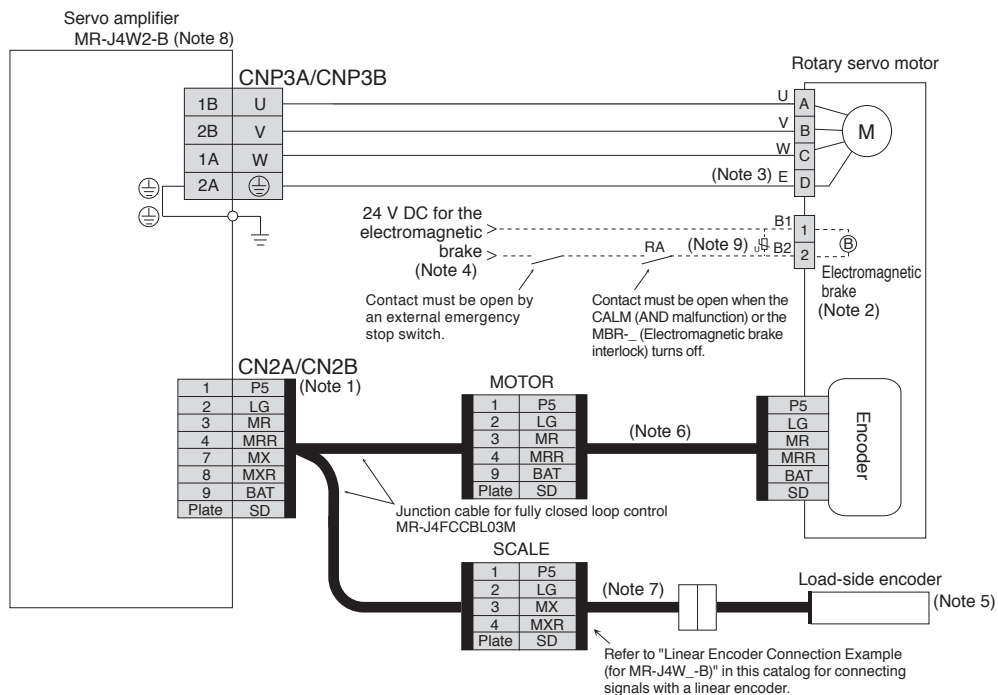

- Notes: 1. For fully closed loop control, the load-side encoder and the servo motor encoder are compatible only with two-wire type communication method. Four-wire type cannot be used.  
 2. This is for the servo motor with electromagnetic brake. The electromagnetic brake terminals (B1, B2) do not have polarity.  
 3. Connect the grounding wire to the cabinet protective earth (PE) terminal via the servo motor.  
 4. Do not use the 24 V DC interface power supply for the electromagnetic brake. Provide a dedicated power supply to the electromagnetic brake.  
 5. For linear encoders, refer to "List of Linear Encoders" under section 3 Linear Servo Motors in this catalog. Refer to "MR-J4W2-\_B MR-J4W3-\_B MR-J4W2-0303B6 Servo Amplifier Instruction Manual" for the fully closed loop control with rotary encoder.  
 6. Encoder cable is available as an option. Refer to "Servo Motor Instruction Manual (Vol. 3)" when fabricating the cables.  
 7. Necessary encoder cables vary depending on the load-side encoder. Refer to relevant Instruction Manual.  
 8. MR-J4W3-B does not support fully closed loop control.  
 9. Be sure to install a surge absorber between B1 and B2.



Be sure to read through Instruction Manual for the actual wiring and use. Use the equipment after you have a full knowledge of the equipment, safety information and instructions.

## Servo Motor Connection Example (Rotary Servo Motor) Fully Closed Loop Control System with MR-J4W2-B

● For HG-UR series

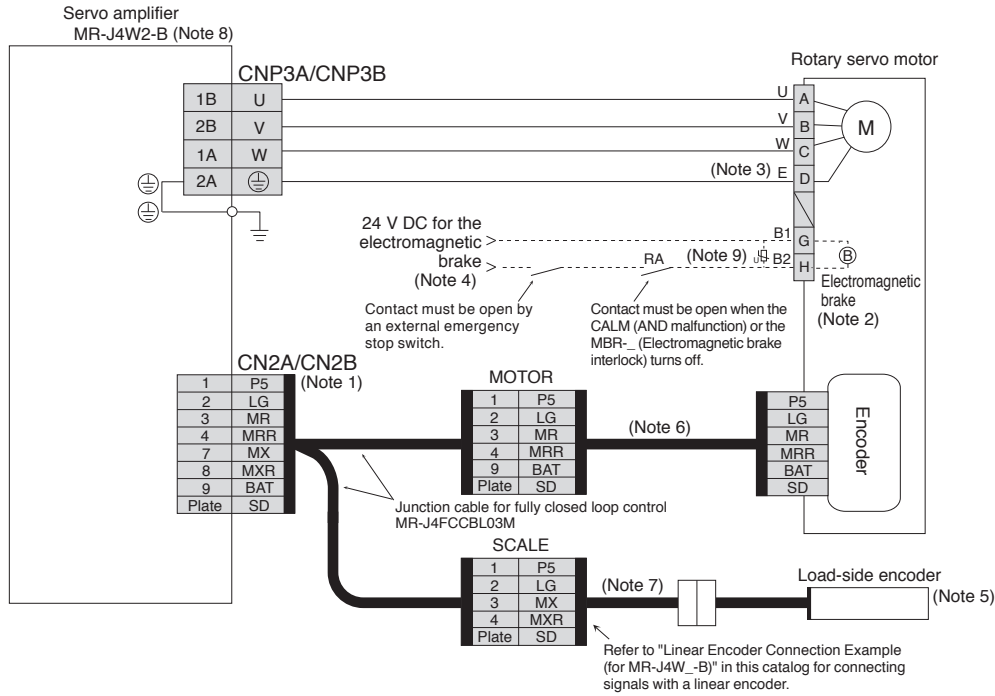

- Notes: 1. For fully closed loop control, the load-side encoder and the servo motor encoder are compatible only with two-wire type communication method. Four-wire type cannot be used.  
 2. This is for the servo motor with electromagnetic brake. The electromagnetic brake terminals (B1, B2) do not have polarity.  
 3. Connect the grounding wire to the cabinet protective earth (PE) terminal via the servo amplifier for grounding the servo motor.  
 4. Do not use the 24 V DC interface power supply for the electromagnetic brake. Provide a dedicated power supply to the electromagnetic brake.  
 5. For linear encoders, refer to "List of Linear Encoders" under section 3 Linear Servo Motors in this catalog. Refer to "MR-J4W2-\_B MR-J4W3-\_B MR-J4W2-0303B6 Servo Amplifier Instruction Manual" for the fully closed loop control with rotary encoder.  
 6. Encoder cable is available as an option. Refer to "Servo Motor Instruction Manual (Vol. 3)" when fabricating the cables.  
 7. Necessary encoder cables vary depending on the load-side encoder. Refer to relevant Instruction Manual.  
 8. MR-J4W3-B does not support fully closed loop control.  
 9. Be sure to install a surge absorber between B1 and B2.



Be sure to read through Instruction Manual for the actual wiring and use. Use the equipment after you have a full knowledge of the equipment, safety information and instructions.

## Servo Motor Connection Example (Linear Servo Motor)

### Linear Servo System with MR-J4W2-B/MR-J4W3-B

● For LM-H3/LM-K2/LM-U2 series

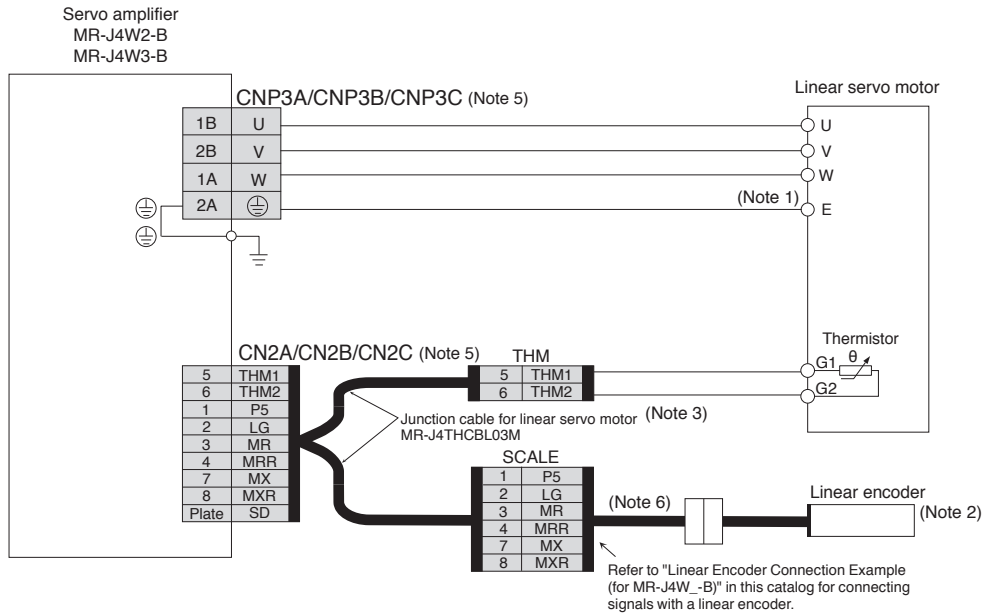

### Linear Encoder Connection Example (for MR-J4W\_-B)

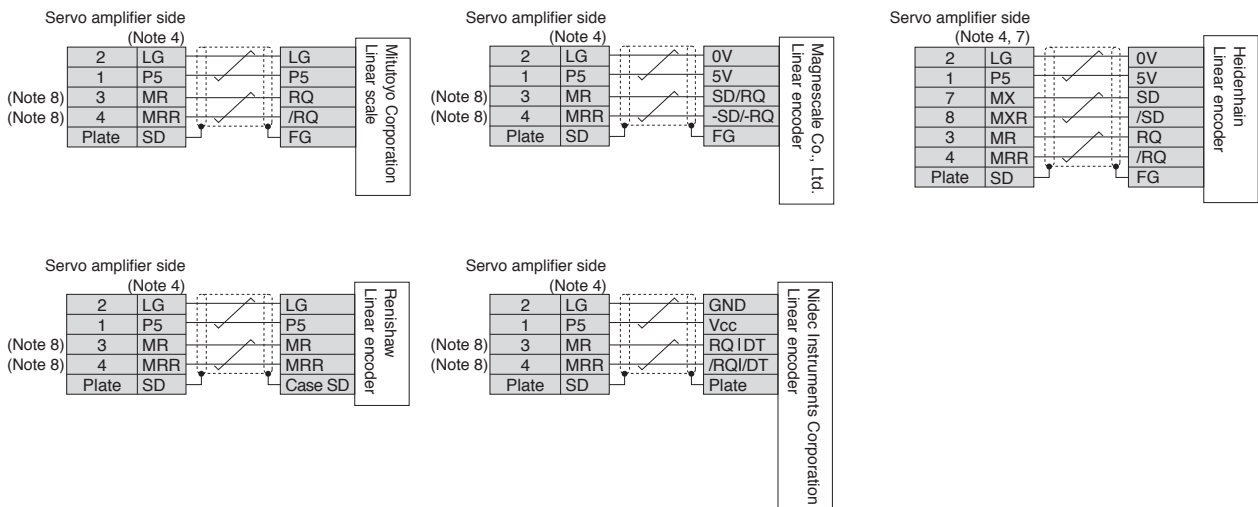

- Notes: 1. Connect the grounding wire to the cabinet protective earth (PE) terminal via the servo amplifier for grounding the servo motor.  
 2. For linear encoders, refer to "List of Linear Encoders" under section 3 Linear Servo Motors in this catalog.  
 3. MR-J4THCBL03M junction cable for linear servo motor is compatible with both two-wire and four-wire type linear encoders.  
 4. For the number of the wire pairs for LG and P5, refer to "Linear Encoder Instruction Manual."  
 5. CNP3C and CN2C connectors are available for MR-J4W3-B servo amplifier.  
 6. Necessary encoder cables vary depending on the linear encoder. Refer to relevant Instruction Manual.  
 7. For fully closed loop control, the load-side encoder and the servo motor encoder are compatible only with two-wire type communication method. Four-wire type cannot be used.  
 8. For the fully closed loop control, MR and MRR of the servo amplifier-side connectors will be connected to MX and MXR of the SCALE connectors of MR-J4FCCBL03M.



Be sure to read through Instruction Manual for the actual wiring and use. Use the equipment after you have a full knowledge of the equipment, safety information and instructions.

## Servo Motor Connection Example (Direct Drive Motor)

● For TM-RG2M/TM-RU2M/TM-RFM series (incremental system)

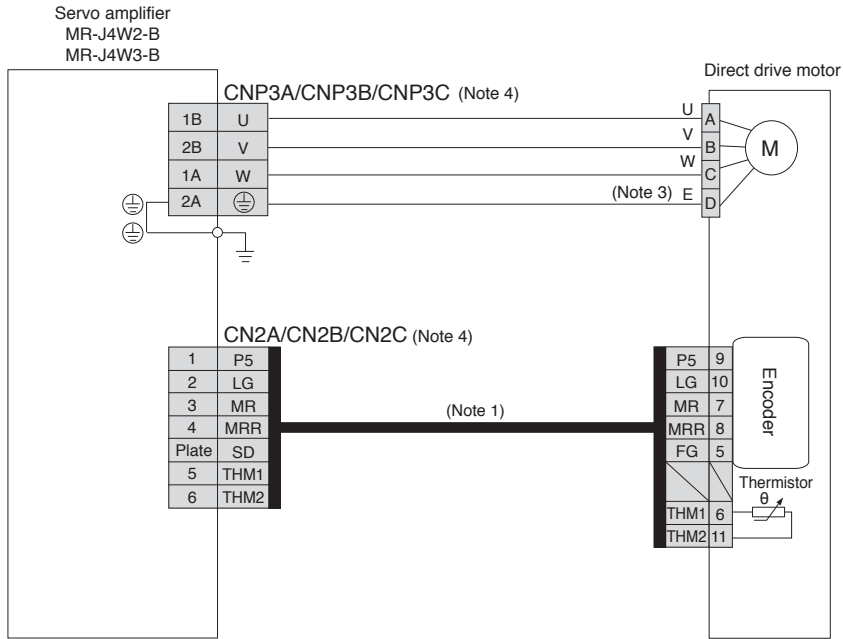

● For TM-RG2M/TM-RU2M/TM-RFM series (absolute position detection system)

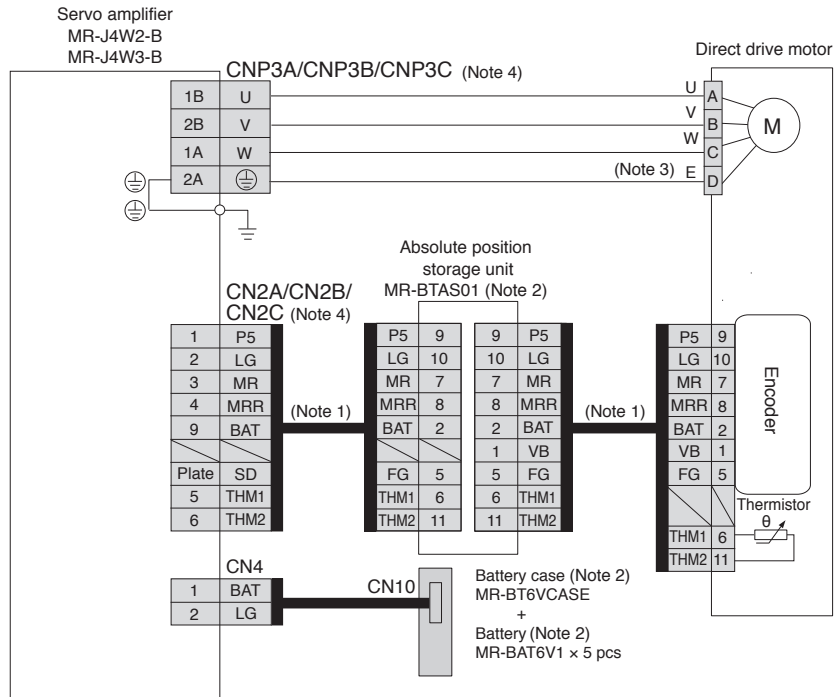

- Notes:
1. Fabricate this encoder cable. Refer to "TM-RFM TM-RG2M TM-RU2M Direct Drive Motor Instruction Manual" for fabricating the encoder cable.
  2. An MR-BTAS01 absolute position storage unit, MR-BT6VCASE battery case, and MR-BAT6V1 batteries (sold as options) are required for absolute position detection system. Refer to relevant Servo Amplifier Instruction Manual and "TM-RFM TM-RG2M TM-RU2M Direct Drive Motor Instruction Manual" for details.
  3. Connect the grounding wire to the cabinet protective earth (PE) terminal via the servo amplifier for grounding the servo motor.
  4. CNP3C and CN2C connectors are available for MR-J4W3-B servo amplifier.

**!** Be sure to read through Instruction Manual for the actual wiring and use. Use the equipment after you have a full knowledge of the equipment, safety information and instructions.

MR-J4W2-0303B6 Standard Wiring Diagram Example

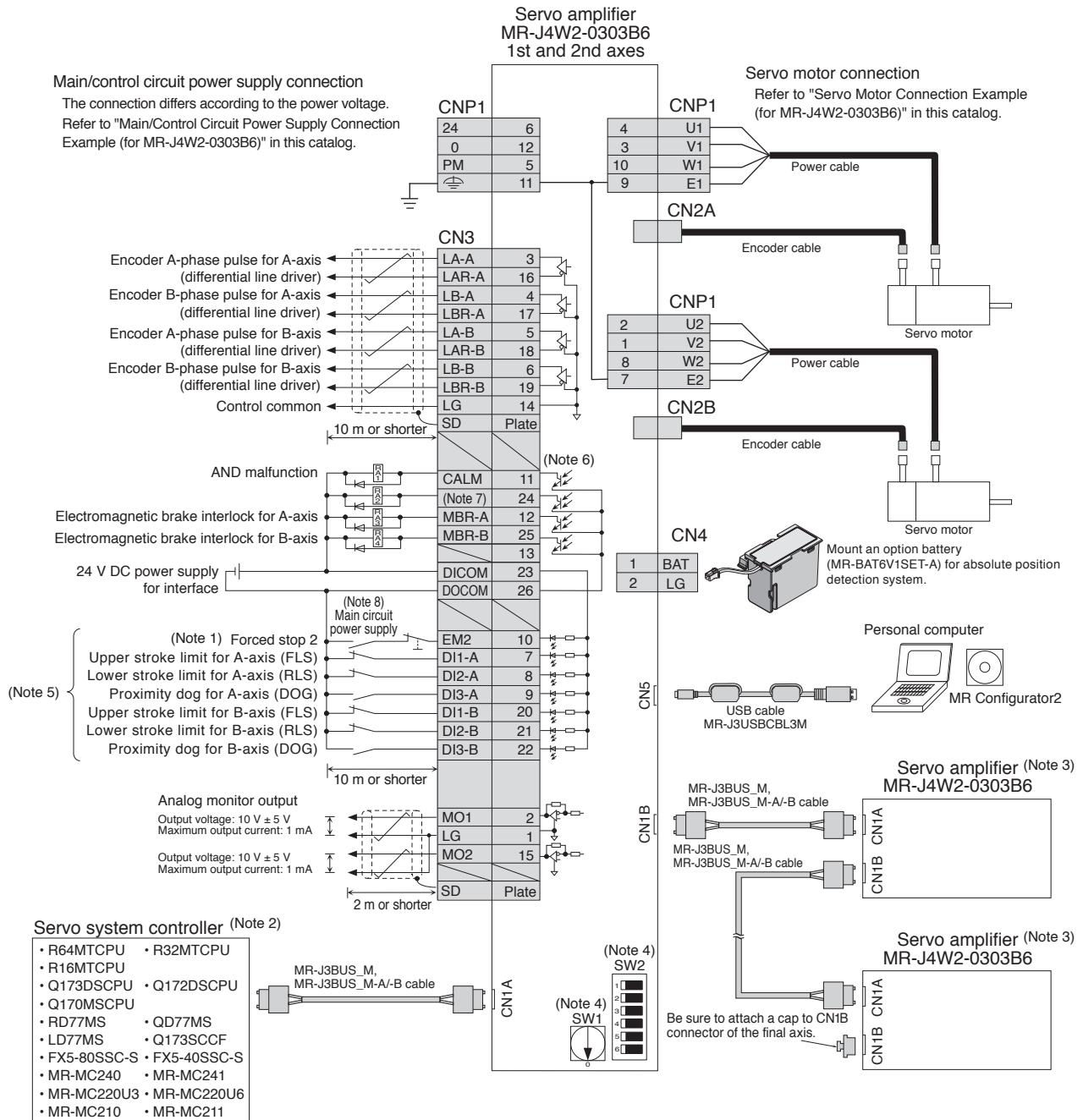

- Notes: 1. The forced stop signal is issued for two axes of the servo amplifier. For overall system, apply the emergency stop on the servo system controller side.  
2. For details such as setting the servo system controllers, refer to the programming or user's manual of each controller.  
3. Connections for the third and following axes are omitted.  
4. Up to 64 axes are set with a combination of an axis selection rotary switch (SW1) and auxiliary axis number setting switches (SW2-5 and SW2-6). Note that the number of the connectable axes depends on the servo system controller specifications.  
5. Devices can be assigned to DI1-A/B, DI2-A/B and DI3-A/B with the servo system controller setting. Refer to the controller instruction manuals for details on setting.  
6. This is for sink wiring. Source wiring is also possible.  
7. C1NP (AND in-position) is assigned to this pin as default. Device for this pin can be changed with [Pr. PD08].  
8. To prevent an unexpected restart of the servo amplifier, create a circuit to turn off EM2 (Forced stop 2) when the main circuit power is turned off.

**!** Be sure to read through Instruction Manual for the actual wiring and use. Use the equipment after you have a full knowledge of the equipment, safety information and instructions.

Servo Amplifiers  
Rotary Servo Motors  
Linear Servo Motors  
Direct Drive Motors  
Options/Peripheral Equipment  
LV5/Wires  
Product List  
Precautions

# Servo Amplifiers

## Main/Control Circuit Power Supply Connection Example (for MR-J4W2-0303B6)

WB

● For 48 V DC

● For 24 V DC

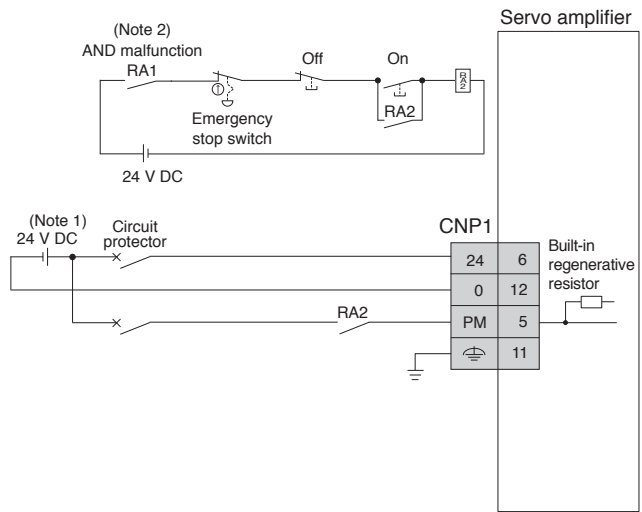
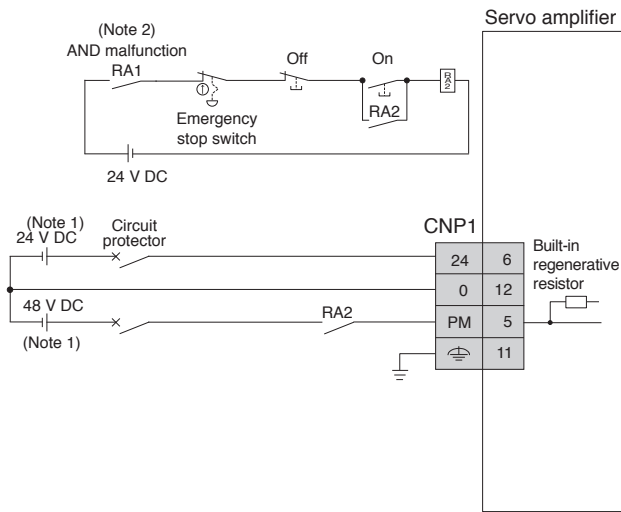

## Servo Motor Connection Example (for MR-J4W2-0303B6)

WB

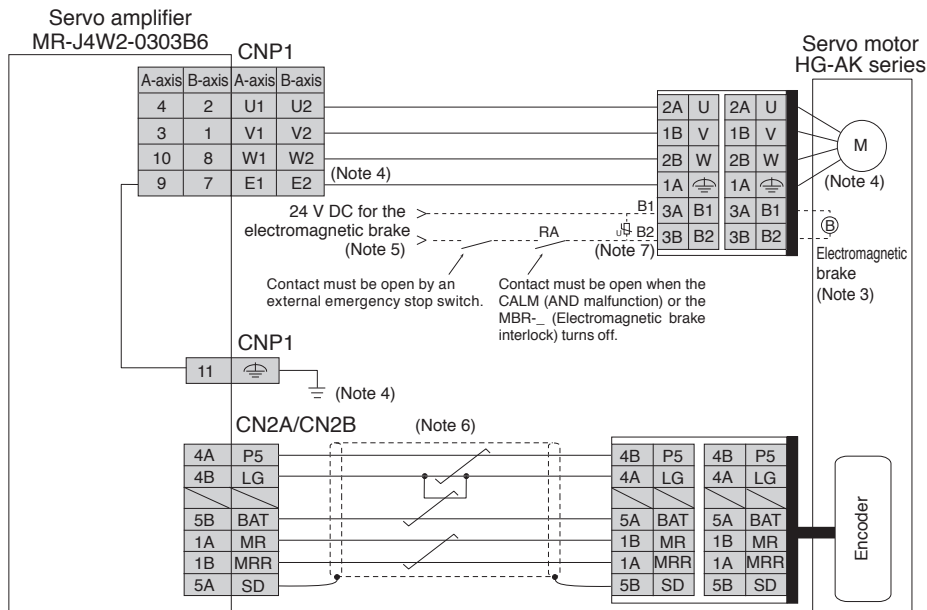

- Notes:
1. Use 48 V DC and 24 V DC power supplies with reinforced insulation, and connect the negative side wiring (0 V) to the power supply terminal.
  2. Select either of the following functions for CALM (AND malfunction) with the servo system controller.
    - 1) The contact opens when an alarm occurs on one of the axes.
    - 2) The contact opens when an alarm occurs on all axes.
  3. This is for the servo motor with electromagnetic brake. The electromagnetic brake terminals (B1, B2) do not have polarity.
  4. Noiseless grounding (⏏) terminals are connected to E1 and E2 terminals in the servo amplifier. Connect the noiseless (⏏) terminals of CNP1 and the grounding terminal of the cabinet.
  5. Do not use the 24 V DC interface power supply for the electromagnetic brake. Provide a dedicated power supply to the electromagnetic brake.
  6. Encoder cable is available as an option. Refer to "Servo Motor Instruction Manual (Vol. 3)" when fabricating the cables.
  7. Be sure to install a surge absorber between B1 and B2.



Be sure to read through Instruction Manual for the actual wiring and use. Use the equipment after you have a full knowledge of the equipment, safety information and instructions.



MR-J4W2-B Dimensions

- MR-J4W2-22B
- MR-J4W2-44B

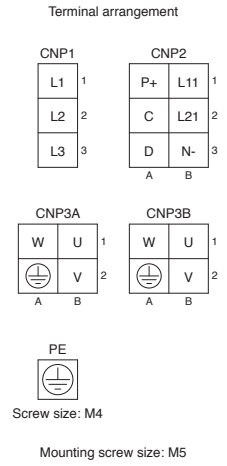
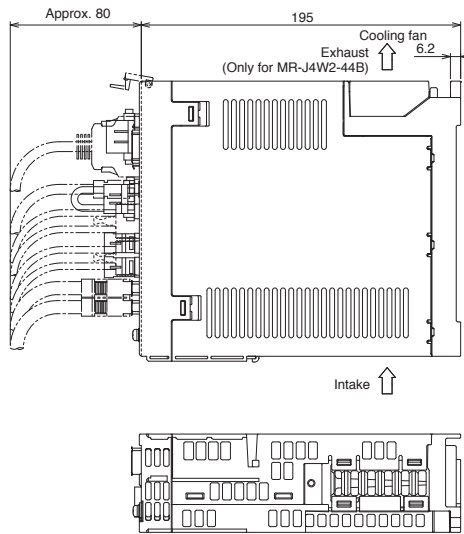
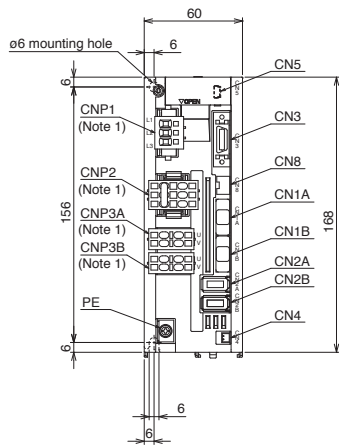

[Unit: mm]

- MR-J4W2-77B
- MR-J4W2-1010B

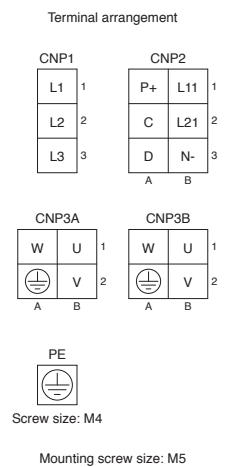
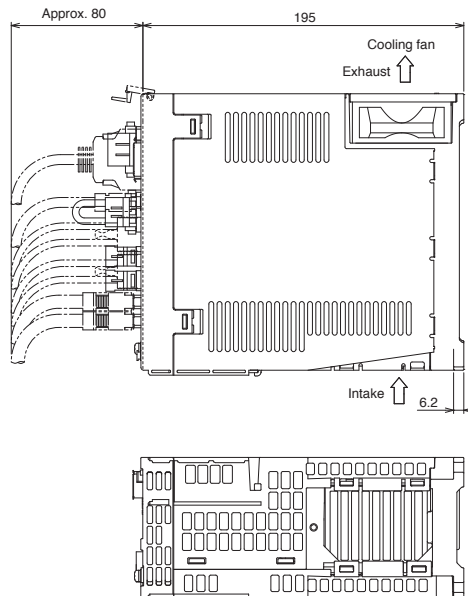
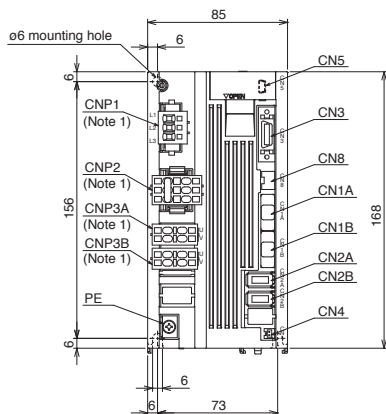

[Unit: mm]

Notes: 1. CNP1, CNP2, CNP3A and CNP3B connectors are supplied with the servo amplifier.

# Servo Amplifiers

WB

## MR-J4W3-B Dimensions

- MR-J4W3-222B
- MR-J4W3-444B

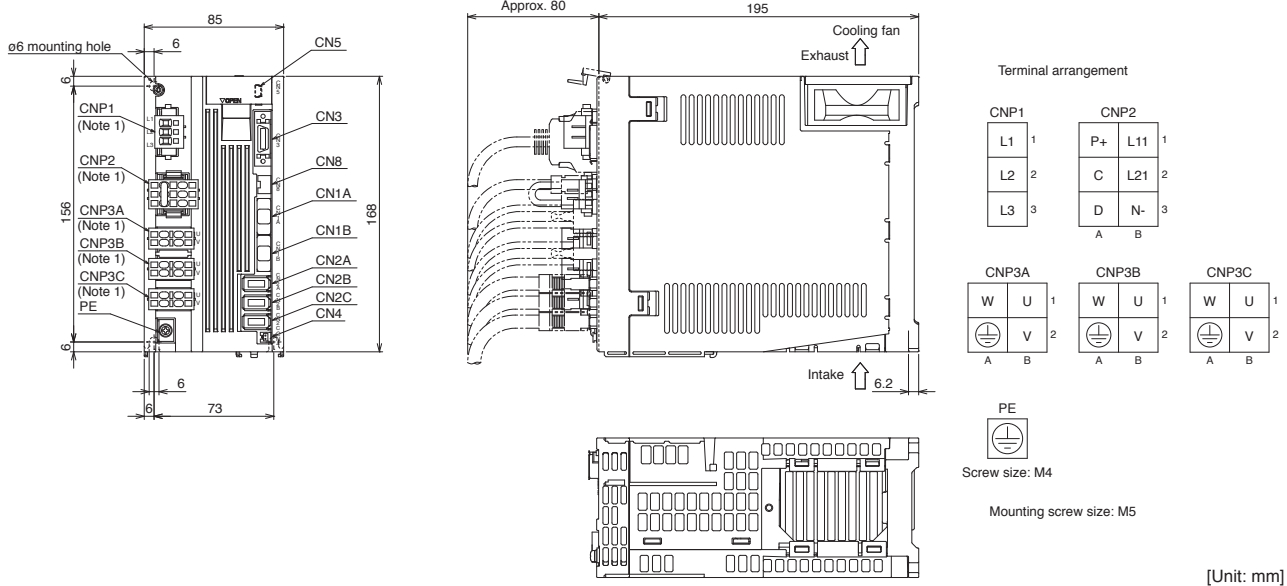

[Unit: mm]

## MR-J4W2-0303B6 Dimensions

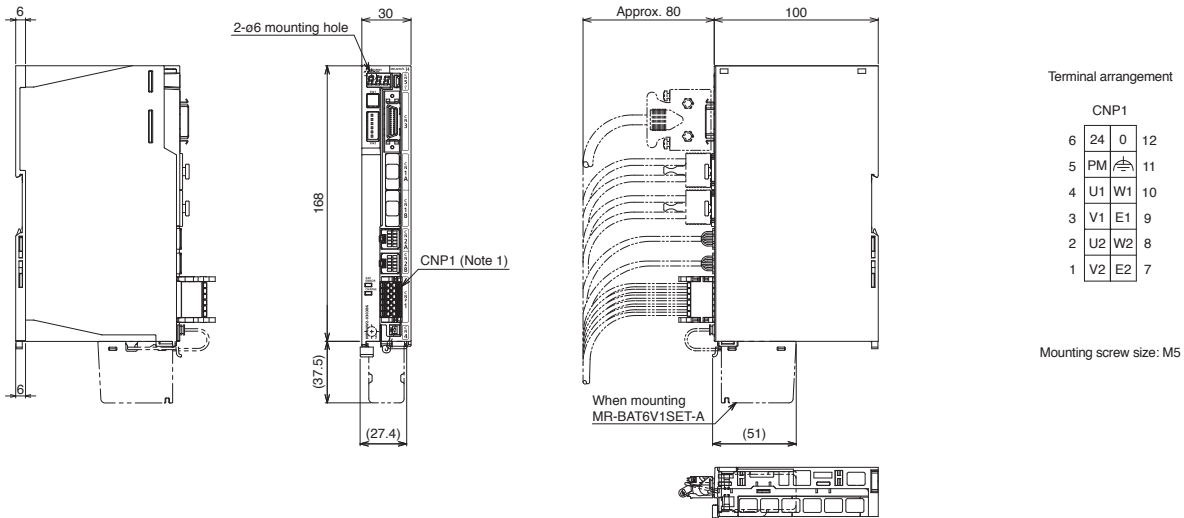

[Unit: mm]

Notes: 1. CNP1, CNP2, CNP3A, CNP3B and CNP3C connectors are supplied with the servo amplifier.

**MR-J4-A/MR-J4-A-RJ Connections with Peripheral Equipment** (Note 1)

**A A-RJ**

Peripheral equipment is connected to MR-J4-A/MR-J4-A-RJ as described below. Connectors, cables, options, and other necessary equipment are available so that users can set up the servo amplifier easily and start using it right away.

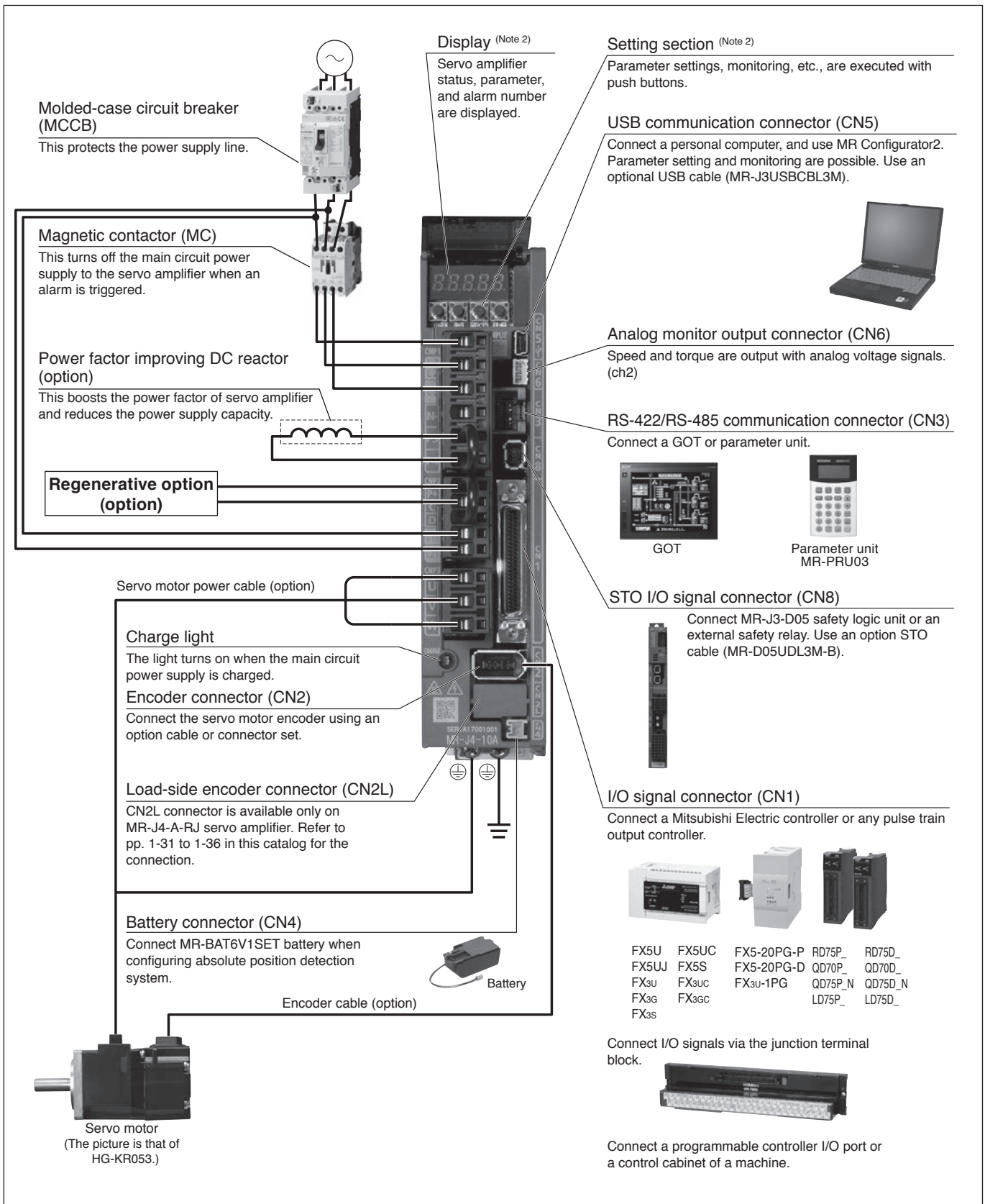

Notes: 1. The connection with the peripheral equipment is an example for MR-J4-350A/MR-J4-350A-RJ or smaller servo amplifiers. Refer to "MR-J4-A\_(-RJ) MR-J4-03A6(-RJ) Servo Amplifier Instruction Manual" for the actual connections.  
2. This picture shows when the display cover is open.

Servo Amplifiers  
Rotary Servo Motors  
Linear Servo Motors  
Direct Drive Motors  
Options/Peripheral Equipment  
LV5/Wires  
Product List  
Precautions

# Servo Amplifiers

## MR-J4-A(1)/MR-J4-A(1)-RJ (General-Purpose Interface) Specifications (200 V/100 V)

**A** **A-RJ**

Servo amplifier model MR-J4-_(-RJ)		10A	20A	40A	60A	70A	100A	200A	350A	500A	700A	11KA	15KA	22KA	10A1	20A1	40A1		
Output	Rated voltage	3-phase 170 V AC																	
	Rated current [A]	1.1	1.5	2.8	3.2	5.8	6.0	11.0	17.0	28.0	37.0	68.0	87.0	126.0	1.1	1.5	2.8		
Main circuit power supply input	Voltage/frequency (Note 1)	AC input	3-phase or 1-phase 200 V AC to 240 V AC, 50 Hz/60 Hz					3-phase or 1-phase 200 V AC to 240 V AC, 50 Hz/60 Hz (Note 16)			3-phase 200 V AC to 240 V AC, 50 Hz/60 Hz					1-phase 100 V AC to 120 V AC, 50 Hz/60 Hz			
		DC input (Note 19)	283 V DC to 340 V DC																
	Rated current (Note 14) [A]	0.9 (1.5)	1.5 (2.5)	2.6 (4.5)	3.2 (5.0) (Note 8)	3.8 (6.5)	5.0 (10.5)	10.5 (15.8)	16.0	21.7	28.9	46.0	64.0	95.0	3.0	5.0	9.0		
	Permissible voltage fluctuation	AC input	3-phase or 1-phase 170 V AC to 264 V AC					3-phase or 1-phase 170 V AC to 264 V AC (Note 16)			3-phase 170 V AC to 264 V AC					1-phase 85 V AC to 132 V AC			
		DC input (Note 19)	241 V DC to 374 V DC																
Permissible frequency fluctuation	±5% maximum																		
Control circuit power supply input	Voltage/frequency	AC input	1-phase 200 V AC to 240 V AC, 50 Hz/60 Hz													1-phase 100 V AC to 120 V AC, 50 Hz/60 Hz			
		DC input (Note 19)	283 V DC to 340 V DC																
	Rated current [A]	0.2									0.3				0.4				
	Permissible voltage fluctuation	AC input	1-phase 170 V AC to 264 V AC													1-phase 85 V AC to 132 V AC			
		DC input (Note 19)	241 V DC to 374 V DC																
	Permissible frequency fluctuation	±5% maximum																	
Power consumption [W]	30									45				30					
Interface power supply	24 V DC ± 10% (required current capacity: 0.5 A (including CN8 connector signals))																		
Control method	Sine-wave PWM control/current control method																		
Permissible regenerative power	Built-in regenerative resistor (Note 2, 3) [W]	-	10	10	10	20	20	100	100	130	170	-	-	-	-	10	10		
	External regenerative resistor (standard accessory) (Note 2, 3, 11, 12) [W]	-	-	-	-	-	-	-	-	-	-	500 (800)	850 (1300)	850 (1300)	-	-	-		
Dynamic brake (Note 4)	Built-in										External option (Note 13)			Built-in					
Communication function	USB	Connect a personal computer (MR Configurator2 compatible)																	
	RS-422/RS-485	1:n communication (up to 32 axes) (Note 10)																	
Encoder output pulse	Compatible (A/B/Z-phase pulse)																		
Analog monitor	2 channels																		
Position control mode	Maximum input pulse frequency	4 Mpulses/s (when using differential receiver), 200 kpulses/s (when using open collector)																	
	Positioning feedback pulse	Encoder resolution: 22 bits																	
	Command pulse multiplying factor	Electronic gear A/B multiple, A: 1 to 16777215, B: 1 to 16777215, 1/10 < A/B < 4000																	
	In-position range setting	0 pulse to ±65535 pulses (command pulse unit)																	
	Error excessive	±3 rotations																	
Torque limit	Set by parameters or external analog input (0 V DC to +10 V DC/maximum torque)																		
Speed control mode	Speed control range	Analog speed command 1:2000, internal speed command 1:5000																	
	Analog speed command input	0 V DC to ±10 V DC/rated speed (Speed at 10 V is changeable with [Pr. PC12].)																	
	Speed fluctuation rate	±0.01% maximum (load fluctuation: 0% to 100%), 0% (power fluctuation: ±10%) ±0.2% maximum (ambient temperature: 25 °C ± 10 °C) only when using analog speed command																	
	Torque limit	Set by parameters or external analog input (0 V DC to +10 V DC/maximum torque)																	
Torque control mode	Analog torque command input	0 V DC to ±8 V DC/maximum torque (input impedance: 10 kΩ to 12 kΩ)																	
	Speed limit	Set by parameters or external analog input (0 V DC to ± 10 V DC/rated speed)																	
Positioning mode (Note 17)	MR-J4-A(1)	Not available																	
	MR-J4-A(1)-RJ	Point table method, program method, indexer method																	
Fully closed loop control	MR-J4-A(1) (Note 9)	Two-wire type communication method																	
	MR-J4-A(1)-RJ	Two-wire/four-wire type communication method																	
Load-side encoder interface	MR-J4-A(1)	Mitsubishi Electric high-speed serial communication																	
	MR-J4-A(1)-RJ	Mitsubishi Electric high-speed serial communication, A/B/Z-phase differential input signal																	
Servo functions	Advanced vibration suppression control II, adaptive filter II, robust filter, auto tuning, one-touch tuning, tough drive function, drive recorder function, machine diagnosis function, power monitoring function, super trace control (Note 15), lost motion compensation function (Note 15)																		

MR-J4-A(1)/MR-J4-A(1)-RJ (General-Purpose Interface) Specifications (200 V/100 V)

A A-RJ

Servo amplifier model MR-J4-_(-RJ)	10A	20A	40A	60A	70A	100A	200A	350A	500A	700A	11KA	15KA	22KA	10A1	20A1	40A1	
Protective functions	Overcurrent shut-off, regenerative overvoltage shut-off, overload shut-off (electronic thermal), servo motor overheat protection, encoder error protection, regenerative error protection, undervoltage protection, instantaneous power failure protection, overspeed protection, error excessive protection, magnetic pole detection protection, linear servo control fault protection																
Functional safety	STO (IEC/EN 61800-5-2)																
Safety performance	Satisfied standards (Note 20)	EN ISO 13849-1:2015 Category 3 PL e, IEC 61508 SIL 3, EN IEC 62061 maximum SIL 3, EN 61800-5-2															
	Response performance	8 ms or less (STO input OFF → energy shut-off)															
	Test pulse input (STO) (Note 7)	Test pulse interval: 1 Hz to 25 Hz, test pulse off time: 1 ms maximum															
	Mean time to dangerous failure (MTTFd)	MTTFd ≥ 100 [years] (314a)															
	Diagnostic coverage (DC)	DC = Medium, 97.6 [%]															
	Probability of dangerous Failure per Hour (PFH)	PFH = 6.4 × 10 <sup>-9</sup> [1/h]															
Structure (IP rating)	Natural cooling, open (IP20)				Force cooling, open (IP20)				Force cooling, open (IP20) (Note 5)				Natural cooling, open (IP20)				
Close mounting	3-phase power input	Possible (Note 6)						Not possible						-			
	1-phase power input	Possible (Note 6)				Not possible				-				Possible (Note 6)			
Environment	Ambient temperature	Operation: 0 °C to 55 °C (non-freezing), storage: -20 °C to 65 °C (non-freezing)															
	Ambient humidity	Operation/storage: 5 %RH to 90 %RH (non-condensing)															
	Ambience	Indoors (no direct sunlight); no corrosive gas, inflammable gas, oil mist or dust															
	Altitude	2000 m or less above sea level (Note 18)															
	Vibration resistance	5.9 m/s <sup>2</sup> at 10 Hz to 55 Hz (directions of X, Y, and Z axes)															
Mass [kg]	0.8	0.8	1.0	1.0	1.4	1.4	2.1	2.3	4.0	6.2	13.4	13.4	18.2	0.8	0.8	1.0	

- Notes: 1. Rated output and speed of a rotary servo motor and a direct drive motor; and continuous thrust and maximum speed of a linear servo motor are applicable when the servo amplifier is operated within the specified power supply voltage and frequency.
2. Select the most suitable regenerative option for your system with our drive system sizing software Motorizer.
3. Refer to "Regenerative Option" in this catalog for the permissible regenerative power [W] when a regenerative option is used.
4. When using the dynamic brake, refer to "MR-J4-\_A\_(-RJ) MR-J4-03A6(-RJ) Servo Amplifier Instruction Manual" for the permissible load to motor inertia ratio and the permissible load to mass ratio.
5. Terminal blocks are excluded.
6. When the servo amplifiers are closely mounted, keep the ambient temperature within 0 °C to 45 °C, or use the servo amplifiers at 75% or less of the effective load ratio.
7. The test pulse is a signal for the external circuit to perform self-diagnosis by turning off the signals to the servo amplifier instantaneously at regular intervals.
8. The rated current is 2.9 A when the servo amplifier is used with a 3-phase power supply and combined with UL or CSA compliant servo motor.
9. Fully closed loop control is supported by the servo amplifiers with software version A5 or later.
10. RS-422/RS-485 communication function is supported by the servo amplifiers with software version A3 or later.
11. The value in brackets is applicable when cooling fans (two units of 92 mm × 92 mm, minimum air flow: 1.0 m<sup>3</sup>/min) are installed, and then [Pr. PA02] is changed.
12. Servo amplifiers without an enclosed regenerative resistor are also available. Refer to "Model Designation for 1-Axis Servo Amplifier" in this catalog for details.
13. Use an external dynamic brake (option) with the servo amplifier. Without the external dynamic brake, a servo motor does not stop immediately at emergency stop and falls in free-run status, causing an accident such as machine collision, etc. Take measures to ensure safety on the entire system when not using the dynamic brake.
14. The value in brackets indicates the rated current when a 1-phase power supply input is used.
15. This function is supported by the servo amplifiers with software version B4 or later.
16. When a 1-phase 200 V AC to 240 V AC power supply is used, use the servo amplifiers at 75% or less of the effective load ratio.
17. Positioning mode is supported by MR-J4-A-RJ servo amplifier with software version B3 or later.
18. Refer to "MR-J4-\_A\_(-RJ) MR-J4-03A6(-RJ) Servo Amplifier Instruction Manual" for the restrictions when using the servo amplifiers at altitude exceeding 1000 m and up to 2000 m above sea level.
19. DC power input is supported by MR-J4-\_A\_-RJ with software version C2 or later and MR-J4-\_A\_-EG. For a connection example of power supply circuit with DC input, refer to "MR-J4-\_A\_(-RJ) MR-J4-03A6(-RJ) Servo Amplifier Instruction Manual".
20. The safety level depends on the setting value of [Pr. PF18 STO diagnosis error detection time] and whether or not STO input diagnosis is performed by TOFB output. Refer to "MR-J4-\_A\_(-RJ) MR-J4-03A6(-RJ) Servo Amplifier Instruction Manual" for details.

Servo Amplifiers  
Rotary Servo Motors  
Linear Servo Motors  
Direct Drive Motors  
Options/Peripheral Equipment  
LV5/Wires  
Product List  
Precautions

# Servo Amplifiers

## MR-J4-DU\_A/MR-J4-DU\_A-RJ (General-Purpose Interface) Specifications (200 V)

A

A-RJ

Drive unit model MR-J4-(-RJ)		DU30KA	DU37KA
Compatible converter unit model		MR-CR55K <sup>(Note 4)</sup>	
Output	Rated voltage	3-phase 170 V AC	
	Rated current [A]	174	204
Main circuit power supply input		Main circuit power is supplied from the resistance regeneration converter unit to the drive unit. <sup>(Note 4)</sup>	
Control circuit power supply input	Voltage/frequency	1-phase 200 V AC to 240 V AC, 50 Hz/60 Hz	
	Rated current [A]	0.3	
	Permissible voltage fluctuation	1-phase 170 V AC to 264 V AC	
	Permissible frequency fluctuation	±5% maximum	
	Power consumption [W]	45	
Interface power supply		24 V DC ± 10% (required current capacity: 0.5 A (including CN8 connector signals))	
Control method		Sine-wave PWM control/current control method	
Dynamic brake <sup>(Note 9)</sup>		External option <sup>(Note 3)</sup>	
Communication function	USB	Connect a personal computer (MR Configurator2 compatible)	
	RS-422/RS-485	1:n communication (up to 32 axes) <sup>(Note 5)</sup>	
Encoder output pulse		Compatible (A/B/Z-phase pulse)	
Analog monitor		2 channels	
Position control mode	Maximum input pulse frequency	4 Mpulses/s (when using differential receiver), 200 kpulses/s (when using open collector)	
	Positioning feedback pulse	Encoder resolution: 22 bits	
	Command pulse multiplying factor	Electronic gear A/B multiple, A: 1 to 16777215, B: 1 to 16777215, 1/10 < A/B < 4000	
	In-position range setting	0 pulse to ±65535 pulses (command pulse unit)	
	Error excessive	±3 rotations	
	Torque limit	Set by parameters or external analog input (0 V DC to +10 V DC/maximum torque)	
Speed control mode	Speed control range	Analog speed command 1:2000, internal speed command 1:5000	
	Analog speed command input	0 V DC to ±10 V DC/rated speed (Speed at 10 V is changeable with [Pr. PC12].)	
	Speed fluctuation rate	±0.01% maximum (load fluctuation: 0% to 100%), 0% (power fluctuation: ±10%) ±0.2% maximum (ambient temperature: 25 °C ± 10 °C) only when using analog speed command	
	Torque limit	Set by parameters or external analog input (0 V DC to +10 V DC/maximum torque)	
Torque control mode	Analog torque command input	0 V DC to ±8 V DC/maximum torque (input impedance: 10 kΩ to 12 kΩ)	
	Speed limit	Set by parameters or external analog input (0 V DC to ± 10 V DC/rated speed)	
Positioning mode <sup>(Note 6)</sup>	MR-J4-DU_A	Not available	
	MR-J4-DU_A-RJ	Point table method, program method, indexer method	
Fully closed loop control	MR-J4-DU_A	Two-wire type communication method	
	MR-J4-DU_A-RJ	Two-wire/four-wire type communication method	
Load-side encoder interface	MR-J4-DU_A	Mitsubishi Electric high-speed serial communication	
	MR-J4-DU_A-RJ	Mitsubishi Electric high-speed serial communication, A/B/Z-phase differential input signal	
Servo functions		Advanced vibration suppression control II, adaptive filter II, robust filter, auto tuning, one-touch tuning, tough drive function, drive recorder function, machine diagnosis function, power monitoring function, super trace control, lost motion compensation function	
Protective functions		Overcurrent shut-off, overload shut-off (electronic thermal), servo motor overheat protection, encoder error protection, undervoltage protection, instantaneous power failure protection, overspeed protection, error excessive protection	

MR-J4-DU\_A/MR-J4-DU\_A-RJ (General-Purpose Interface) Specifications (200 V)

A A-RJ

Drive unit model MR-J4-(-RJ)		DU30KA	DU37KA
Functional safety		STO (IEC/EN 61800-5-2)	
Safety performance	Satisfied standards <sup>(Note 8)</sup>	EN ISO 13849-1:2015 Category 3 PL e, IEC 61508 SIL 3, EN IEC 62061 maximum SIL 3, EN 61800-5-2	
	Response performance	8 ms or less (STO input OFF → energy shut-off)	
	Test pulse input (STO) <sup>(Note 2)</sup>	Test pulse interval: 1 Hz to 25 Hz, test pulse off time: 1 ms maximum	
	Mean time to dangerous failure (MTTFd)	MTTFd ≥ 100 [years] (314a)	
	Diagnostic coverage (DC)	DC = Medium, 97.6 [%]	
	Probability of dangerous Failure per Hour (PFH)	PFH = 6.4 × 10 <sup>-9</sup> [1/h]	
Structure (IP rating)		Force cooling, open (IP20) <sup>(Note 1)</sup>	
Environment	Ambient temperature	Operation: 0 °C to 55 °C (non-freezing), storage: -20 °C to 65 °C (non-freezing)	
	Ambient humidity	Operation/storage: 5 %RH to 90 %RH (non-condensing)	
	Ambience	Indoors (no direct sunlight); no corrosive gas, inflammable gas, oil mist or dust	
	Altitude	2000 m or less above sea level <sup>(Note 7)</sup>	
	Vibration resistance	5.9 m/s <sup>2</sup> at 10 Hz to 55 Hz (directions of X, Y and Z axes)	
Mass [kg]		21	21

Notes: 1. Terminal blocks are excluded.

- The test pulse is a signal for the external circuit to perform self-diagnosis by turning off the signals to the drive unit instantaneously at regular intervals.
- Use an external dynamic brake (option) with the drive unit. Without the external dynamic brake, a servo motor does not stop immediately at emergency stop and falls in free-run status, causing an accident such as machine collision, etc. Take measures to ensure safety on the entire system when not using the dynamic brake.
- Refer to "MR-CR Resistance Regeneration Converter Unit Specifications (200 V/400 V)" on p. 1-53 in this catalog for the specifications of the resistance regeneration converter unit.
- RS-485 communication function is supported by the drive units manufactured in January 2015 or later. Refer to "MR-CV\_ MR-CR55K\_ MR-J4-DU\_B\_(-RJ) MR-J4-DU\_A\_(-RJ) Instruction Manual" for checking procedure of manufacture data.
- Positioning mode is supported by MR-J4-DU\_A-RJ drive unit with software version B3 or later.
- Refer to "MR-CV\_ MR-CR55K\_ MR-J4-DU\_B\_(-RJ) MR-J4-DU\_A\_(-RJ) Instruction Manual" for the restrictions when using the servo amplifiers at altitude exceeding 1000 m and up to 2000 m above sea level.
- The safety level depends on the setting value of [Pr. PF18 STO diagnosis error detection time] and whether or not STO input diagnosis is performed by TOFB output. Refer to "MR-J4- A\_(-RJ) MR-J4-03A6(-R) Servo Amplifier Instruction Manual" for details.
- When using the dynamic brake, refer to "MR-CV\_ MR-CR55K\_ MR-J4-DU\_B\_(-RJ) MR-J4-DU\_A\_(-RJ) Instruction Manual" for the permissible load to motor inertia ratio.

Servo Amplifiers

Rotary Servo Motors

Linear Servo Motors

Direct Drive Motors

Options/Peripheral Equipment

LVS/Wires

Product List

Precautions

# Servo Amplifiers

## MR-J4-A4/MR-J4-A4-RJ (General-Purpose Interface) Specifications (400 V)

**A** **A-RJ**

Servo amplifier model MR-J4-(-RJ)		60A4	100A4	200A4	350A4	500A4	700A4	11KA4	15KA4	22KA4	
Output	Rated voltage	3-phase 323 V AC									
	Rated current [A]	1.5	2.8	5.4	8.6	14.0	17.0	32.0	41.0	63.0	
Main circuit power supply input	Voltage/frequency <sup>(Note 1)</sup>	3-phase 380 V AC to 480 V AC, 50 Hz/60 Hz									
	Rated current [A]	1.4	2.5	5.1	7.9	10.8	14.4	23.1	31.8	47.6	
	Permissible voltage fluctuation	3-phase 323 V AC to 528 V AC									
	Permissible frequency fluctuation	±5% maximum									
Control circuit power supply input	Voltage/frequency	1-phase 380 V AC to 480 V AC, 50 Hz/60 Hz									
	Rated current [A]	0.1				0.2					
	Permissible voltage fluctuation	1-phase 323 V AC to 528 V AC									
	Permissible frequency fluctuation	±5% maximum									
	Power consumption [W]	30				45					
Interface power supply		24 V DC ± 10% (required current capacity: 0.5 A (including CN8 connector signals))									
Control method		Sine-wave PWM control/current control method									
Permissible regenerative power	Built-in regenerative resistor <sup>(Note 2, 3)</sup> [W]	15	15	100	100	130 <sup>(Note 10)</sup>	170 <sup>(Note 10)</sup>	-	-	-	
	External regenerative resistor (standard accessory) <sup>(Note 2, 3, 7, 8)</sup> [W]	-	-	-	-	-	-	500 (800)	850 (1300)	850 (1300)	
Dynamic brake <sup>(Note 4)</sup>		Built-in					External option <sup>(Note 9)</sup>				
Communication function	USB	Connect a personal computer (MR Configurator2 compatible)									
	RS-422/RS-485	1:n communication (up to 32 axes) <sup>(Note 12)</sup>									
Encoder output pulse		Compatible (A/B/Z-phase pulse)									
Analog monitor		2 channels									
Position control mode	Maximum input pulse frequency	4 Mpulses/s (when using differential receiver), 200 kpulses/s (when using open collector)									
	Positioning feedback pulse	Encoder resolution: 22 bits									
	Command pulse multiplying factor	Electronic gear A/B multiple, A: 1 to 16777215, B: 1 to 16777215, 1/10 < A/B < 4000									
	In-position range setting	0 pulse to ±65535 pulses (command pulse unit)									
	Error excessive	±3 rotations									
	Torque limit	Set by parameters or external analog input (0 V DC to +10 V DC/maximum torque)									
Speed control mode	Speed control range	Analog speed command 1:2000, internal speed command 1:5000									
	Analog speed command input	0 V DC to ±10 V DC/rated speed (Speed at 10 V is changeable with [Pr. PC12].)									
	Speed fluctuation rate	±0.01% maximum (load fluctuation: 0% to 100%), 0% (power fluctuation: ±10%) ±0.2% maximum (ambient temperature: 25 °C ± 10 °C) only when using analog speed command									
	Torque limit	Set by parameters or external analog input (0 V DC to +10 V DC/maximum torque)									
Torque control mode	Analog torque command input	0 V DC to ±8 V DC/maximum torque (input impedance: 10 kΩ to 12 kΩ)									
	Speed limit	Set by parameters or external analog input (0 V DC to ± 10 V DC/rated speed)									
Positioning mode <sup>(Note 13)</sup>	MR-J4-A4	Not available									
	MR-J4-A4-RJ	Point table method, program method, indexer method									
Fully closed loop control	MR-J4-A4	Two-wire type communication method									
	MR-J4-A4-RJ	Two-wire/four-wire type communication method									
Load-side encoder interface	MR-J4-A4	Mitsubishi Electric high-speed serial communication									
	MR-J4-A4-RJ	Mitsubishi Electric high-speed serial communication, A/B/Z-phase differential input signal									
Servo functions		Advanced vibration suppression control II, adaptive filter II, robust filter, auto tuning, one-touch tuning, tough drive function, drive recorder function, machine diagnosis function, power monitoring function, super trace control <sup>(Note 11)</sup> , lost motion compensation function <sup>(Note 11)</sup>									
Protective functions		Overcurrent shut-off, regenerative overvoltage shut-off, overload shut-off (electronic thermal), servo motor overheat protection, encoder error protection, regenerative error protection, undervoltage protection, instantaneous power failure protection, overspeed protection, error excessive protection, magnetic pole detection protection, linear servo control fault protection									



MR-J4-A4/MR-J4-A4-RJ (General-Purpose Interface) Specifications (400 V)

A A-RJ

Servo amplifier model MR-J4-(-RJ)		60A4	100A4	200A4	350A4	500A4	700A4	11KA4	15KA4	22KA4
Functional safety		STO (IEC/EN 61800-5-2)								
Safety performance	Satisfied standards (Note 15)	EN ISO 13849-1:2015 Category 3 PL e, IEC 61508 SIL 3, EN IEC 62061 maximum SIL 3, EN 61800-5-2								
	Response performance	8 ms or less (STO input OFF → energy shut-off)								
	Test pulse input (STO) (Note 6)	Test pulse interval: 1 Hz to 25 Hz, test pulse off time: 1 ms maximum								
	Mean time to dangerous failure (MTTFd)	MTTFd ≥ 100 [years] (314a)								
	Diagnostic coverage (DC)	DC = Medium, 97.6 [%]								
	Probability of dangerous Failure per Hour (PFH)	PFH = 6.4 × 10 <sup>-9</sup> [1/h]								
Structure (IP rating)		Natural cooling, open (IP20)	Force cooling, open (IP20)		Force cooling, open (IP20) (Note 5)					
Close mounting		Not possible								
Environment	Ambient temperature	Operation: 0 °C to 55 °C (non-freezing), storage: -20 °C to 65 °C (non-freezing)								
	Ambient humidity	Operation/storage: 5 %RH to 90 %RH (non-condensing)								
	Ambience	Indoors (no direct sunlight); no corrosive gas, inflammable gas, oil mist or dust								
	Altitude	2000 m or less above sea level (Note 14)								
	Vibration resistance	5.9 m/s <sup>2</sup> at 10 Hz to 55 Hz (directions of X, Y and Z axes)								
Mass [kg]		1.7	1.7	2.1	3.6	4.3	6.5	13.4	13.4	18.2

- Notes: 1. Rated output and speed of a rotary servo motor, and continuous thrust and maximum speed of a linear servo motor are applicable when the servo amplifier is operated within the specified power supply voltage and frequency.
2. Select the most suitable regenerative option for your system with our drive system sizing software Motorizer.
3. Refer to "Regenerative Option" in this catalog for the permissible regenerative power [W] when a regenerative option is used.
4. When using the dynamic brake, refer to "MR-J4-A(-RJ) MR-J4-03A6(-RJ) Servo Amplifier Instruction Manual" for the permissible load to motor inertia ratio and the permissible load to mass ratio.
5. Terminal blocks are excluded.
6. The test pulse is a signal for the external circuit to perform self-diagnosis by turning off the signals to the servo amplifier instantaneously at regular intervals.
7. The value in brackets is applicable when cooling fans (two units of 92 mm × 92 mm, minimum air flow: 1.0 m<sup>3</sup>/min) are installed, and then [Pr. PA02] is changed.
8. Servo amplifiers without an enclosed regenerative resistor are also available. Refer to "Model Designation for 1-Axis Servo Amplifier" in this catalog for details.
9. Use an external dynamic brake (option) with the servo amplifier. Without the external dynamic brake, a servo motor does not stop immediately at emergency stop and falls in free-run status, causing an accident such as machine collision, etc. Take measures to ensure safety on the entire system when not using the dynamic brake.
10. The servo amplifier built-in regenerative resistor is compatible with the maximum torque deceleration when the servo motor is used within the rated speed and the recommended load to motor inertia ratio. Contact your local sales office if the operating motor speed or the load to motor inertia ratio exceeds the rated speed or the recommended ratio.
11. This function is supported by the servo amplifiers with software version B4 or later.
12. RS-485 communication function is supported by the servo amplifiers manufactured in November 2014 or later. Refer to "MR-J4-A(-RJ) MR-J4-03A6(-RJ) Servo Amplifier Instruction Manual" for checking procedure of manufacture data.
13. Positioning mode is supported by MR-J4-A4-RJ servo amplifier with software version B3 or later.
14. Refer to "MR-J4-A(-RJ) MR-J4-03A6(-RJ) Servo Amplifier Instruction Manual" for the restrictions when using the servo amplifiers at altitude exceeding 1000 m and up to 2000 m above sea level.
15. The safety level depends on the setting value of [Pr. PF18 STO diagnosis error detection time] and whether or not STO input diagnosis is performed by TOFB output. Refer to "MR-J4-A(-RJ) MR-J4-03A6(-RJ) Servo Amplifier Instruction Manual" for details.

Servo Amplifiers

Rotary Servo Motors

Linear Servo Motors

Direct Drive Motors

Options/Peripheral Equipment

LVS/Wires

Product List

Precautions

# Servo Amplifiers

## MR-J4-DU\_A4/MR-J4-DU\_A4-RJ (General-Purpose Interface) Specifications (400 V)

**A**
**A-RJ**

Drive unit model MR-J4-(-RJ)		DU30KA4	DU37KA4	DU45KA4	DU55KA4
Compatible converter unit model		MR-CR55K4 (Note 4)			
Output	Rated voltage	3-phase 323 V AC			
	Rated current [A]	87	102	131	143
Main circuit power supply input		Main circuit power is supplied from the resistance regeneration converter unit to the drive unit. (Note 4)			
Control circuit power supply input	Voltage/frequency	1-phase 380 V AC to 480 V AC, 50 Hz/60 Hz			
	Rated current [A]	0.2			
	Permissible voltage fluctuation	1-phase 323 V AC to 528 V AC			
	Permissible frequency fluctuation	±5% maximum			
	Power consumption [W]	45			
Interface power supply		24 V DC ± 10% (required current capacity: 0.5 A (including CN8 connector signals))			
Control method		Sine-wave PWM control/current control method			
Dynamic brake (Note 9)		External option (Note 3)			
Communication function	USB	Connect a personal computer (MR Configurator2 compatible)			
	RS-422/RS-485	1:n communication (up to 32 axes) (Note 5)			
Encoder output pulse		Compatible (A/B/Z-phase pulse)			
Analog monitor		2 channels			
Position control mode	Maximum input pulse frequency	4 Mpulses/s (when using differential receiver), 200 kpulses/s (when using open collector)			
	Positioning feedback pulse	Encoder resolution: 22 bits			
	Command pulse multiplying factor	Electronic gear A/B multiple, A: 1 to 16777215, B: 1 to 16777215, 1/10 < A/B < 4000			
	In-position range setting	0 pulse to ±65535 pulses (command pulse unit)			
	Error excessive	±3 rotations			
	Torque limit	Set by parameters or external analog input (0 V DC to +10 V DC/maximum torque)			
Speed control mode	Speed control range	Analog speed command 1:2000, internal speed command 1:5000			
	Analog speed command input	0 V DC to ±10 V DC/rated speed (Speed at 10 V is changeable with [Pr. PC12].)			
	Speed fluctuation rate	±0.01% maximum (load fluctuation: 0% to 100%), 0% (power fluctuation: ±10%) ±0.2% maximum (ambient temperature: 25 °C ± 10 °C) only when using analog speed command			
	Torque limit	Set by parameters or external analog input (0 V DC to +10 V DC/maximum torque)			
Torque control mode	Analog torque command input	0 V DC to ±8 V DC/maximum torque (input impedance: 10 kΩ to 12 kΩ)			
	Speed limit	Set by parameters or external analog input (0 V DC to ± 10 V DC/rated speed)			
Positioning mode (Note 6)	MR-J4-DU_A4	Not available			
	MR-J4-DU_A4-RJ	Point table method, program method, indexer method			
Fully closed loop control	MR-J4-DU_A4	Two-wire type communication method			
	MR-J4-DU_A4-RJ	Two-wire/four-wire type communication method			
Load-side encoder interface	MR-J4-DU_A4	Mitsubishi Electric high-speed serial communication			
	MR-J4-DU_A4-RJ	Mitsubishi Electric high-speed serial communication, A/B/Z-phase differential input signal			
Servo functions		Advanced vibration suppression control II, adaptive filter II, robust filter, auto tuning, one-touch tuning, tough drive function, drive recorder function, machine diagnosis function, power monitoring function, super trace control, lost motion compensation function			
Protective functions		Overcurrent shut-off, overload shut-off (electronic thermal), servo motor overheat protection, encoder error protection, undervoltage protection, instantaneous power failure protection, overspeed protection, error excessive protection,			

MR-J4-DU\_A4/MR-J4-DU\_A4-RJ (General-Purpose Interface) Specifications (400 V)

A A-RJ

Drive unit model MR-J4-(-RJ)		DU30KA4	DU37KA4	DU45KA4	DU55KA4
Functional safety		STO (IEC/EN 61800-5-2)			
Safety performance	Satisfied standards (Note 8)	EN ISO 13849-1:2015 Category 3 PL e, IEC 61508 SIL 3, EN IEC 62061 maximum SIL 3, EN 61800-5-2			
	Response performance	8 ms or less (STO input OFF → energy shut-off)			
	Test pulse input (STO) (Note 2)	Test pulse interval: 1 Hz to 25 Hz, test pulse off time: 1 ms maximum			
	Mean time to dangerous failure (MTTFd)	MTTFd ≥ 100 [years] (314a)			
	Diagnostic coverage (DC)	DC = Medium, 97.6 [%]			
	Probability of dangerous Failure per Hour (PFH)	PFH = 6.4 × 10 <sup>-9</sup> [1/h]			
Structure (IP rating)		Force cooling, open (IP20) (Note 1)			
Environment	Ambient temperature	Operation: 0 °C to 55 °C (non-freezing), storage: -20 °C to 65 °C (non-freezing)			
	Ambient humidity	Operation/storage: 5 %RH to 90 %RH (non-condensing)			
	Ambience	Indoors (no direct sunlight); no corrosive gas, inflammable gas, oil mist or dust			
	Altitude	2000 m or less above sea level (Note 7)			
	Vibration resistance	5.9 m/s <sup>2</sup> at 10 Hz to 55 Hz (directions of X, Y and Z axes)			
Mass [kg]		16	16	21	21

Notes: 1. Terminal blocks are excluded.

- The test pulse is a signal for the external circuit to perform self-diagnosis by turning off the signals to the drive unit instantaneously at regular intervals.
- Use an external dynamic brake (option) with the drive unit. Without the external dynamic brake, a servo motor does not stop immediately at emergency stop and falls in free-run status, causing an accident such as machine collision, etc. Take measures to ensure safety on the entire system when not using the dynamic brake.
- Refer to "MR-CR Resistance Regeneration Converter Unit Specifications (200 V/400 V)" on p. 1-53 in this catalog for the specifications of the resistance regeneration converter unit.
- RS-485 communication function is supported by the drive units manufactured in January 2015 or later. Refer to "MR-CV\_MR-CR55K\_MR-J4-DU\_B\_(-RJ) MR-J4-DU\_A\_(-RJ) Instruction Manual" for checking procedure of manufacture data.
- Positioning mode is supported by MR-J4-DU\_A4-RJ drive unit with software version B3 or later.
- Refer to "MR-CV\_MR-CR55K\_MR-J4-DU\_B\_(-RJ) MR-J4-DU\_A\_(-RJ) Instruction Manual" for the restrictions when using the servo amplifiers at altitude exceeding 1000 m and up to 2000 m above sea level.
- The safety level depends on the setting value of [Pr. PF18 STO diagnosis error detection time] and whether or not STO input diagnosis is performed by TOFB output. Refer to "MR-J4-A\_(-RJ) MR-J4-03A6(-R) Servo Amplifier Instruction Manual" for details.
- When using the dynamic brake, refer to "MR-CV\_MR-CR55K\_MR-J4-DU\_B\_(-RJ) MR-J4-DU\_A\_(-RJ) Instruction Manual" for the permissible load to motor inertia ratio.

Servo Amplifiers

Rotary Servo Motors

Linear Servo Motors

Direct Drive Motors

Options/Peripheral Equipment

LVS/Wires

Product List

Precautions

# Servo Amplifiers

## MR-J4-03A6/MR-J4-03A6-RJ (General-Purpose Interface) Specifications

**A** **A-RJ**

Servo amplifier model		MR-J4-03A6	MR-J4-03A6-RJ
Output	Rated voltage	3-phase 13 V AC	
	Rated current [A]	2.4	
Main circuit power supply input	Voltage <sup>(Note 1)</sup>	48 V DC/24 V DC <sup>(Note 2)</sup>	
	Rated current [A]	For 48 V DC: 1.2 A For 24 V DC: 2.4 A	
	Permissible voltage fluctuation	For 48 V DC: 40.8 V DC to 55.2 V DC For 24 V DC: 21.6 V DC to 26.4 V DC	
Control circuit power supply input	Voltage	24 V DC	
	Rated current [A]	0.2	
	Permissible voltage fluctuation	21.6 V DC to 26.4 V DC	
	Power consumption [W]	5.0	
Interface power supply		24 V DC $\pm$ 10% (required current capacity: 0.3 A)	
Control method		Sine-wave PWM control/current control method	
Permissible regenerative power of the built-in regenerative resistor [W]		0.7	
Dynamic brake <sup>(Note 4)</sup>		Built-in <sup>(Note 3)</sup>	
Communication function	USB	Connect a personal computer (MR Configurator2 compatible)	
	RS-422	1:n communication (up to 32 axes)	
Encoder output pulse		Compatible (A/B/Z-phase pulse)	
Analog monitor		2 channels	
Position control mode	Maximum input pulse frequency	4 Mpulses/s (when using differential receiver), 200 kpulses/s (when using open collector)	
	Positioning feedback pulse	Encoder resolution: 18 bits	
	Command pulse multiplying factor	Electronic gear A/B multiple, A: 1 to 16777215, B: 1 to 16777215, 1/10 < A/B < 4000	
	In-position range setting	0 pulse to $\pm$ 65535 pulses (command pulse unit)	
	Error excessive	$\pm$ 3 rotations	
	Torque limit	Set by parameters or external analog input (0 V DC to +10 V DC/maximum torque)	
Speed control mode	Speed control range	Analog speed command 1:2000, internal speed command 1:5000	
	Analog speed command input	0 V DC to $\pm$ 10 V DC/rated speed (Speed at 10 V is changeable with [Pr. PC12].)	
	Speed fluctuation rate	$\pm$ 0.01% maximum (load fluctuation: 0% to 100%), 0% (power fluctuation: $\pm$ 10%) $\pm$ 0.2% maximum (ambient temperature: 25 °C $\pm$ 10 °C) only when using analog speed command	
	Torque limit	Set by parameters or external analog input (0 V DC to +10 V DC/maximum torque)	
Torque control mode	Analog torque command input	0 V DC to $\pm$ 8 V DC/maximum torque (input impedance: 10 k $\Omega$ to 12 k $\Omega$ )	
	Speed limit	Set by parameters or external analog input (0 V DC to $\pm$ 10 V DC/rated speed)	
Positioning mode		Not available	Point table method, program method, indexer method
Fully closed loop control		Not compatible	
Servo functions		Advanced vibration suppression control II, adaptive filter II, robust filter, auto tuning, one-touch tuning, vibration tough drive function, drive recorder function, machine diagnosis function, power monitoring function	
Protective functions		Overcurrent shut-off, regenerative overvoltage shut-off, overload shut-off (electronic thermal), servo motor overheat protection, encoder error protection, regenerative error protection, undervoltage protection, instantaneous power failure protection, overspeed protection, error excessive protection	
Structure (IP rating)		Natural cooling, open (IP20)	
Close mounting		Possible <sup>(Note 5)</sup>	
DIN rail mounting (35 mm wide)		Possible	
Environment	Ambient temperature	Operation: 0 °C to 55 °C (non-freezing), storage: -20 °C to 65 °C (non-freezing)	
	Ambient humidity	Operation/storage: 5 %RH to 90 %RH (non-condensing)	
	Ambience	Indoors (no direct sunlight); no corrosive gas, inflammable gas, oil mist or dust	
	Altitude	1000 m or less above sea level	
Vibration resistance		5.9 m/s <sup>2</sup> at 10 Hz to 55 Hz (directions of X, Y and Z axes)	
Mass [kg]		0.2	

Notes: 1. Rated output and speed of a rotary servo motor are applicable when the servo amplifier is operated within the specified power supply voltage.

2. Initial value is 48 V DC. For 24 V DC, set [Pr. PC27] to "\_ \_1 \_". Servo motor characteristics vary depending on whether the voltage is 48 V DC or 24 V DC. Refer to "HG-AK Series (Ultra-Compact Size, Ultra-Small Capacity) Specifications" and "HG-AK Series Torque Characteristics" in this catalog.

3. The dynamic brake is electronic. The electronic dynamic brake does not operate when the control circuit power is off. It may not operate depending on alarms and warnings. Refer to "MR-J4-A\_(-RJ) MR-J4-03A6(-RJ) Servo Amplifier Instruction Manual" for details.

4. When using the dynamic brake, refer to "MR-J4-A\_(-RJ) MR-J4-03A6(-RJ) Servo Amplifier Instruction Manual" for the permissible load to motor inertia ratio.

5. When the servo amplifiers are closely mounted, keep the ambient temperature within 0 °C to 45 °C.

**MR-J4-A/MR-J4-A-RJ Standard Wiring Diagram Example: Position Control Operation** (Note 6)

**A A-RJ**

Connecting to RD75D

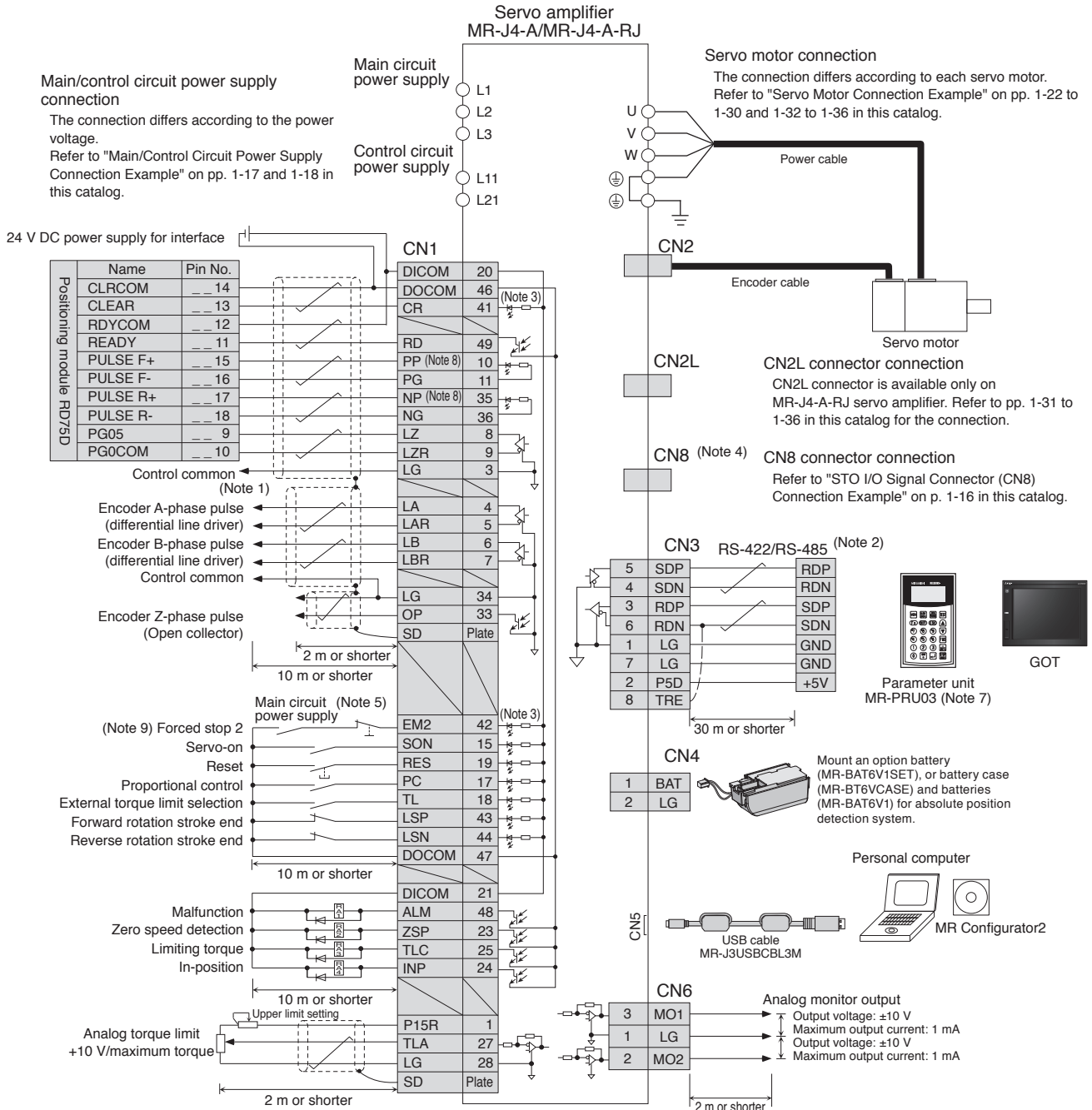

**!** Be sure to read through Instruction Manual for the actual wiring and use. Use the equipment after you have a full knowledge of the equipment, safety information and instructions.

Servo Amplifiers  
Rotary Servo Motors  
Linear Servo Motors  
Direct Drive Motors  
Options/Peripheral Equipment  
LV5/Wires  
Product List  
Precautions

## MR-J4-A/MR-J4-A-RJ Standard Wiring Diagram Example: Speed Control Operation <sup>(Note 5)</sup>

A A-RJ

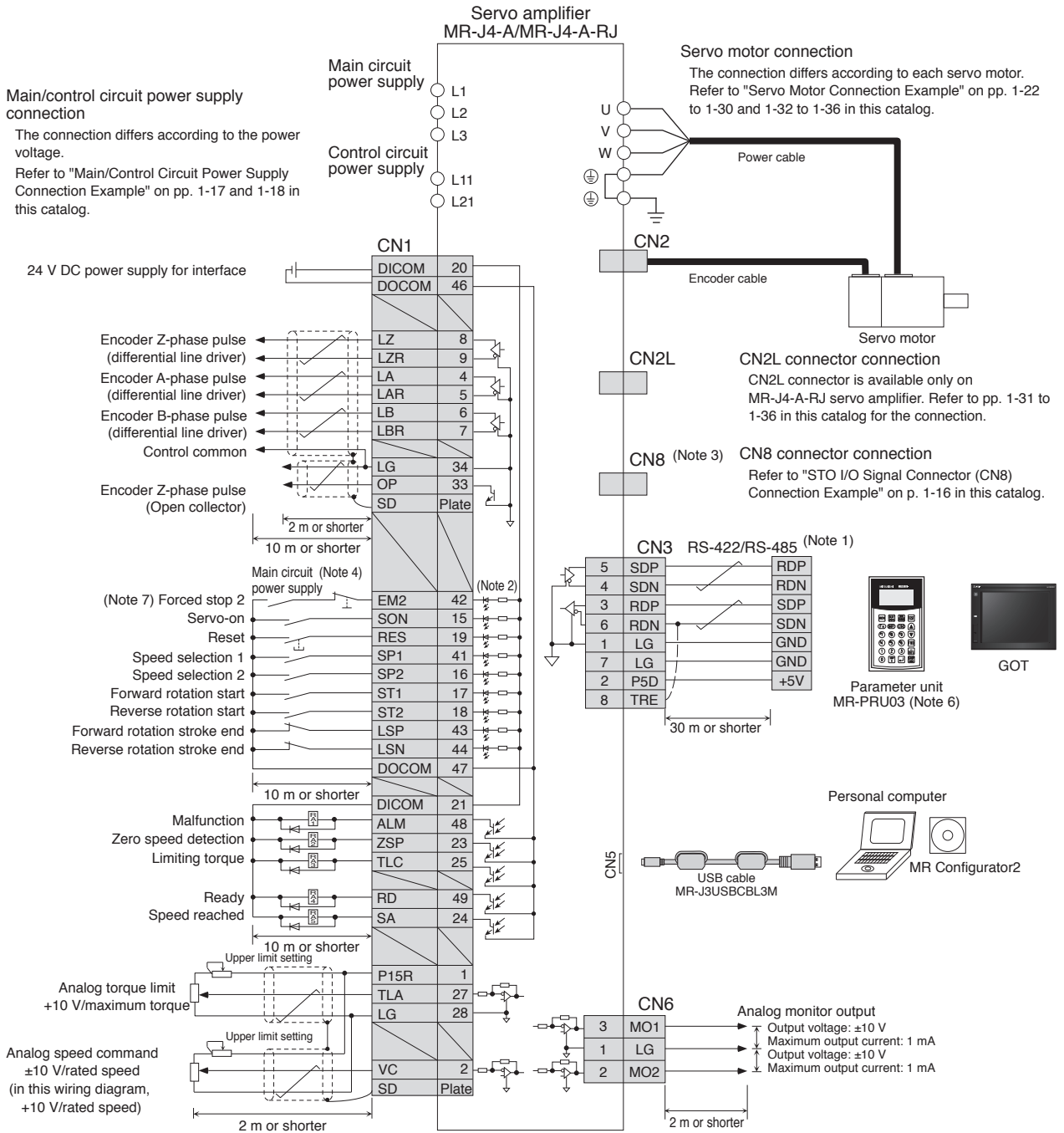

- Notes: 1. It is also possible to connect a personal computer to CN3 connector with an RS-422/RS-232C conversion cable. However, USB (CN5 connector) and RS-422/RS-485 (CN3 connector) communication functions are mutually exclusive. Do not use them at the same time. Refer to "Products on the Market for Servo Amplifiers" in this catalog for the RS-422/RS-232C conversion cable.
2. This is for sink wiring. Source wiring is also possible.
3. Be sure to attach a short-circuit connector supplied with the servo amplifier when the STO function is not used.
4. To prevent an unexpected restart of the servo amplifier, create a circuit to turn off EM2 (Forced stop 2) when the main circuit power is turned off.
5. This standard wiring diagram is common for 200 V AC, 100 V AC and 400 V AC type servo amplifiers.
6. When using MR-PRU03 parameter unit, use a commercial LAN cable (EIA568 compliant), and keep the wire length to a maximum of 10 m.
7. The forced stop signal is issued for the servo amplifier. For overall system, apply the emergency stop on the controller side.



Be sure to read through Instruction Manual for the actual wiring and use. Use the equipment after you have a full knowledge of the equipment, safety information and instructions.

**MR-J4-A/MR-J4-A-RJ Standard Wiring Diagram Example: Torque Control Operation** (Note 5)

**A A-RJ**

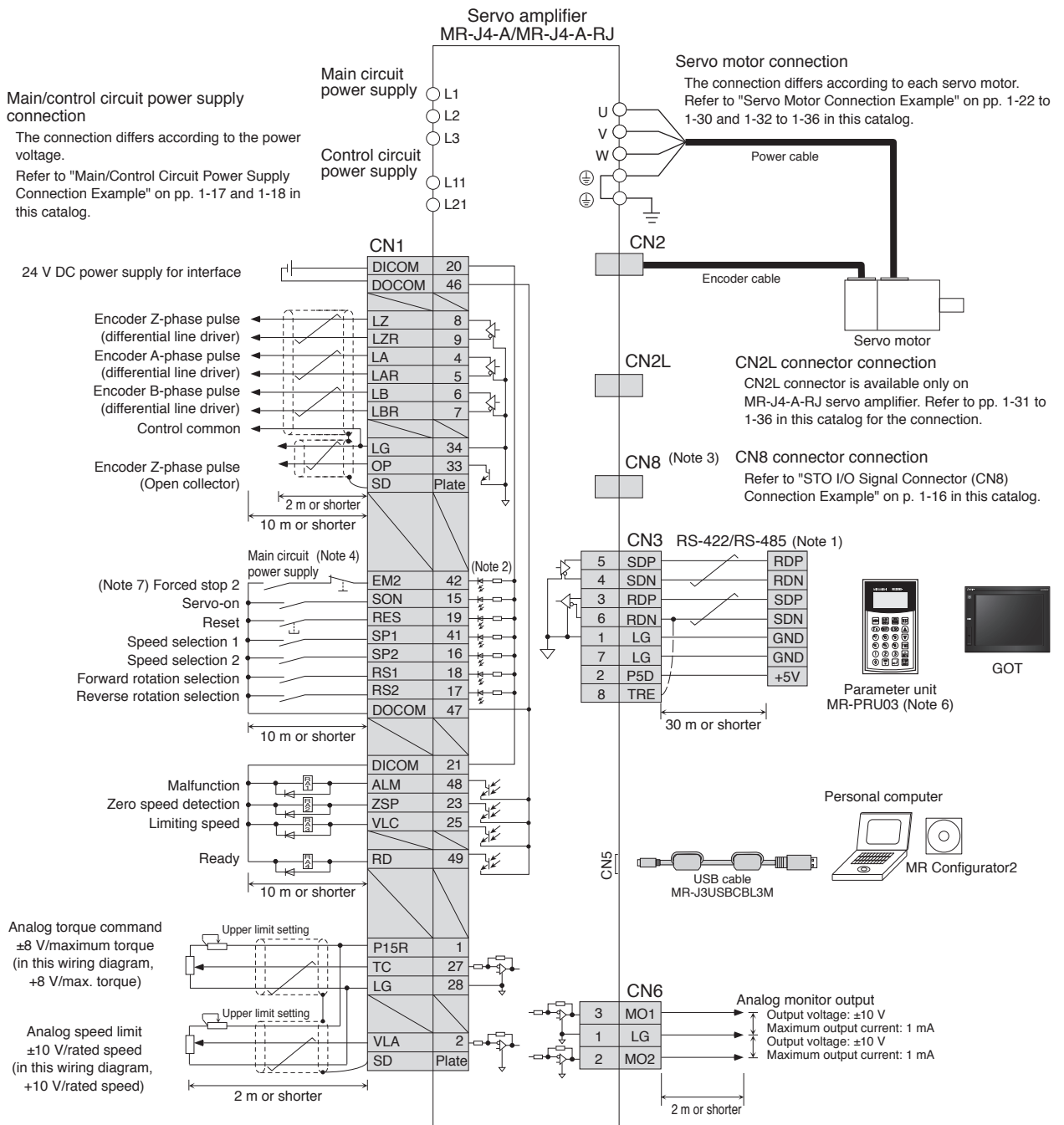

- Notes: 1. It is also possible to connect a personal computer to CN3 connector with an RS-422/RS-232C conversion cable. However, USB (CN5 connector) and RS-422/RS-485 (CN3 connector) communication functions are mutually exclusive. Do not use them at the same time. Refer to "Products on the Market for Servo Amplifiers" in this catalog for the RS-422/RS-232C conversion cable.
2. This is for sink wiring. Source wiring is also possible.
3. Be sure to attach a short-circuit connector supplied with the servo amplifier when the STO function is not used.
4. To prevent an unexpected restart of the servo amplifier, create a circuit to turn off EM2 (Forced stop 2) when the main circuit power is turned off.
5. This standard wiring diagram is common for 200 V AC, 100 V AC and 400 V AC type servo amplifiers.
6. When using MR-PRU03 parameter unit, use a commercial LAN cable (EIA568 compliant), and keep the wire length to a maximum of 10 m.
7. The forced stop signal is issued for the servo amplifier. For overall system, apply the emergency stop on the controller side.

**!** Be sure to read through Instruction Manual for the actual wiring and use. Use the equipment after you have a full knowledge of the equipment, safety information and instructions.

Servo Amplifiers

Rotary Servo Motors

Linear Servo Motors

Direct Drive Motors

Options/Peripheral Equipment

LVS/Wires

Product List

Precautions

## MR-J4-03A6/MR-J4-03A6-RJ Standard Wiring Diagram Example: Position Control Operation

A A-RJ

### Connecting to RD75D

#### Main/control circuit power supply connection

The connection differs according to the power voltage.  
Refer to "Main/Control Circuit Power Supply Connection Example (for MR-J4-03A6/MR-J4-03A6-RJ)" on p. 1-107 in this catalog.

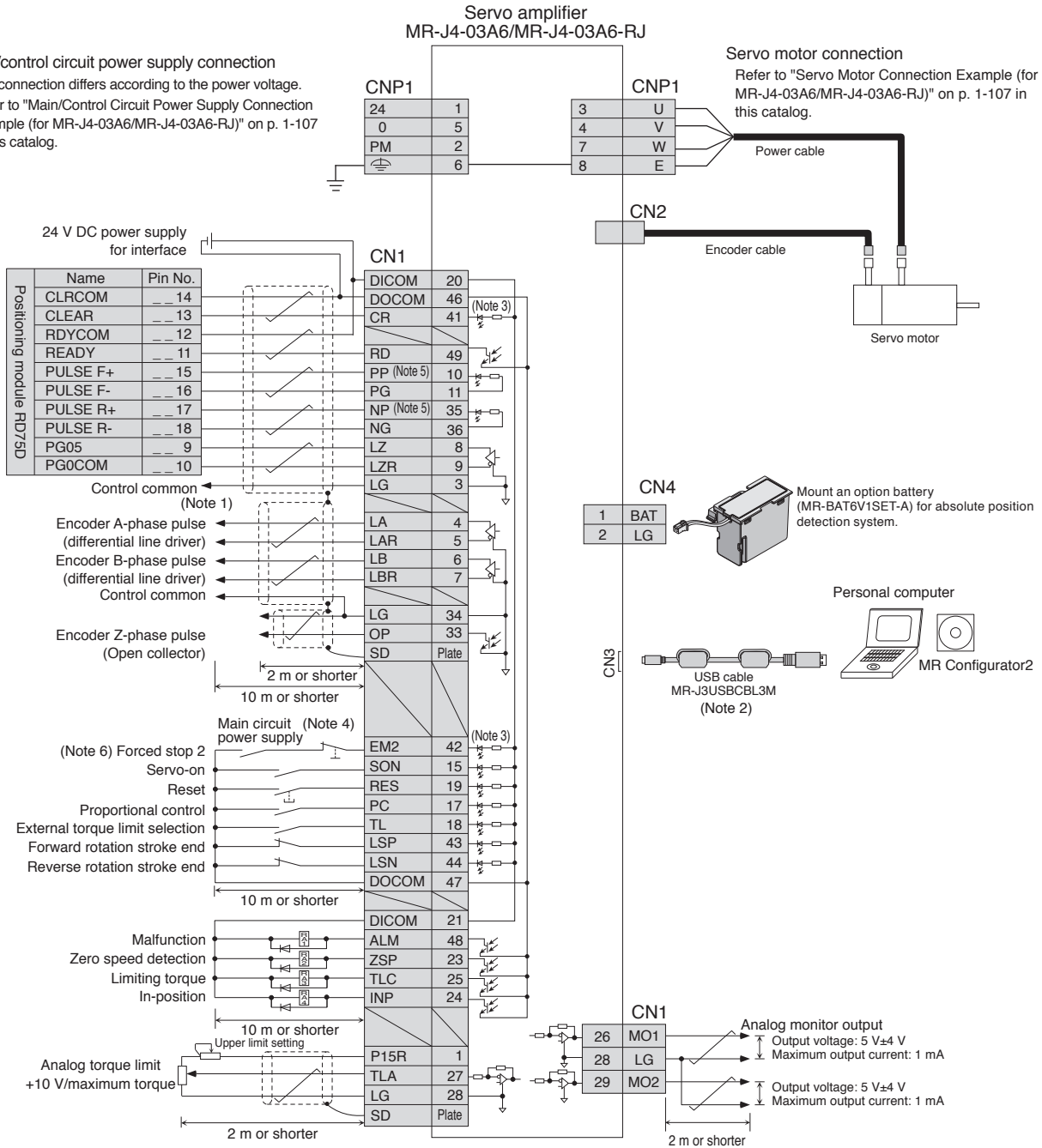

- Notes: 1. This connection is not necessary for RD75D Positioning module. Note that the connection between LG and control common terminal is recommended for some Positioning modules to improve noise tolerance.  
2. USB and RS-422 communication functions are mutually exclusive. Do not use them at the same time.  
3. This is for sink wiring. Source wiring is also possible.  
4. To prevent an unexpected restart of the servo amplifier, create a circuit to turn off EM2 (Forced stop 2) when the main circuit power is turned off.  
5. Pulse train input is available with sink input and source input of open-collector type. When using the source input, use PP2 and NP2 terminals. Refer to "MR-J4-03A6(-RJ) Servo Amplifier Instruction Manual" for details.  
6. The forced stop signal is issued for the servo amplifier. For overall system, apply the emergency stop on the controller side.



Be sure to read through Instruction Manual for the actual wiring and use. Use the equipment after you have a full knowledge of the equipment, safety information and instructions.



**MR-J4-03A6/MR-J4-03A6-RJ Standard Wiring Diagram Example: Speed Control Operation**

**A A-RJ**

Servo Amplifiers  
Rotary Servo Motors  
Linear Servo Motors  
Direct Drive Motors  
Options/Peripheral Equipment  
LV5/Wires  
Product List  
Precautions

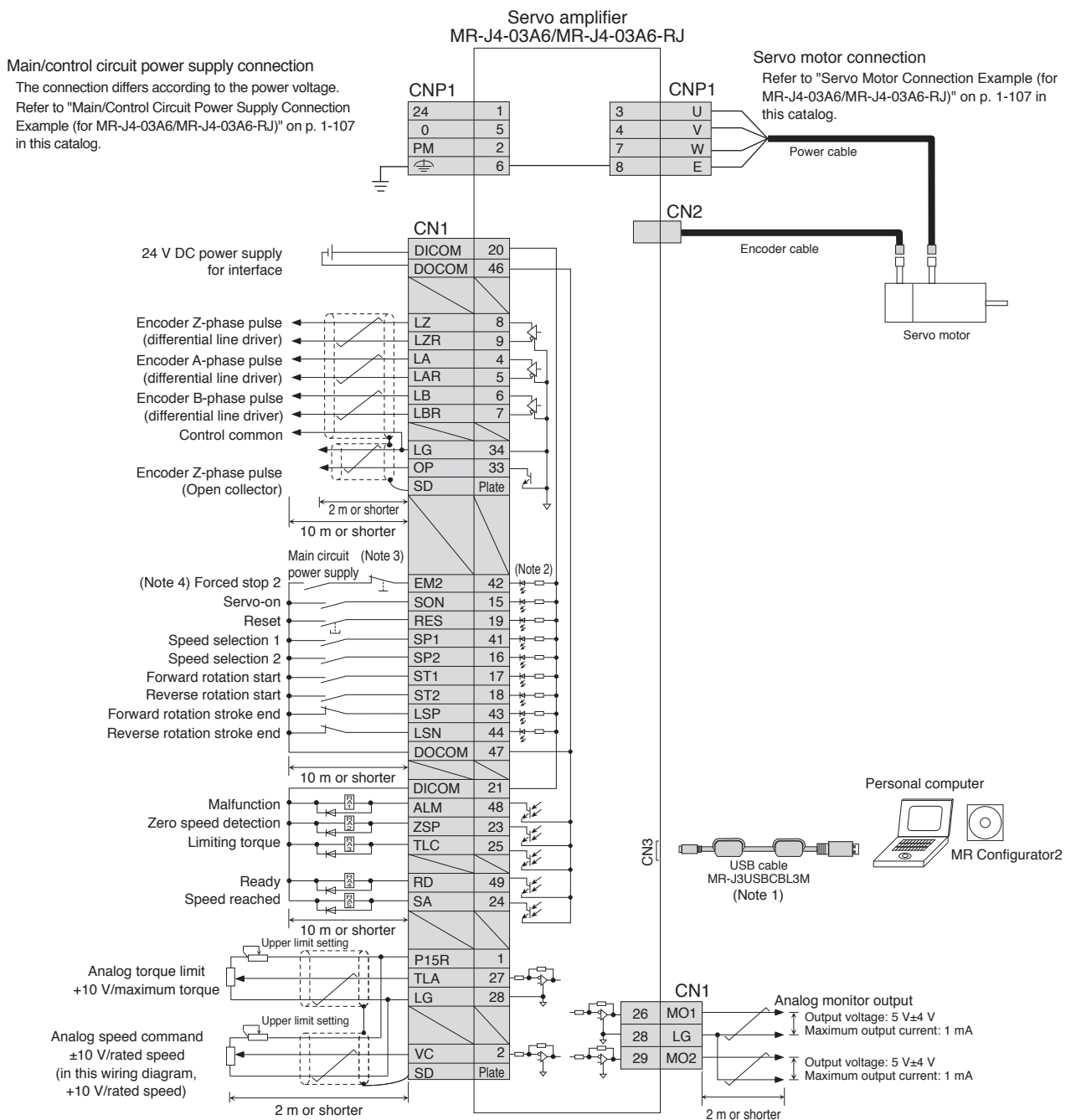

**!** Be sure to read through Instruction Manual for the actual wiring and use. Use the equipment after you have a full knowledge of the equipment, safety information and instructions.

## MR-J4-03A6/MR-J4-03A6-RJ Standard Wiring Diagram Example: Torque Control Operation

A A-RJ

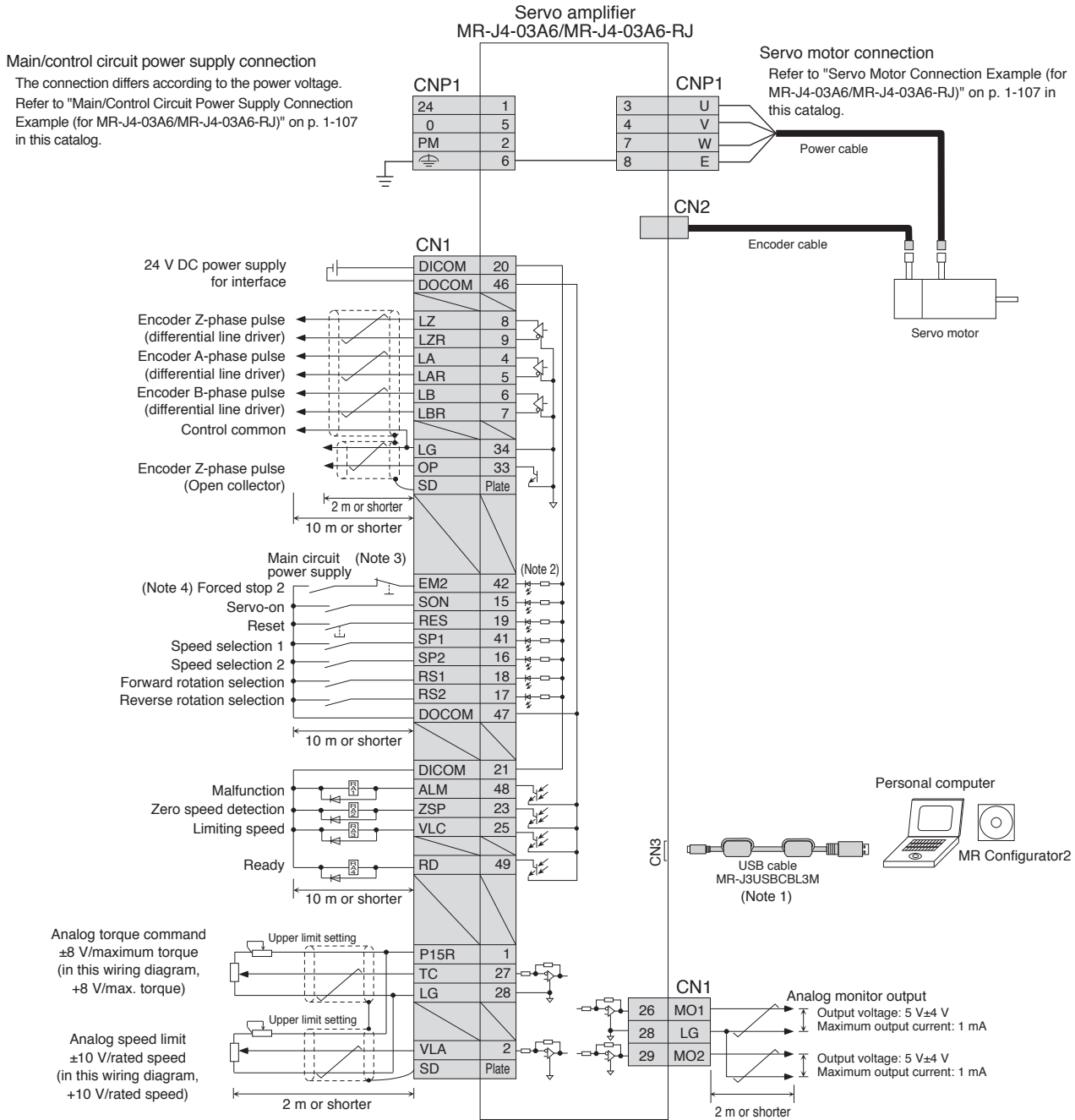

- Notes: 1. USB and RS-422 communication functions are mutually exclusive. Do not use them at the same time.  
 2. This is for sink wiring. Source wiring is also possible.  
 3. To prevent an unexpected restart of the servo amplifier, create a circuit to turn off EM2 (Forced stop 2) when the main circuit power is turned off.  
 4. The forced stop signal is issued for the servo amplifier. For overall system, apply the emergency stop on the controller side.



Be sure to read through Instruction Manual for the actual wiring and use. Use the equipment after you have a full knowledge of the equipment, safety information and instructions.

MR-J4-03A6/MR-J4-03A6-RJ RS-422 Serial Communication Connection Example

A A-RJ

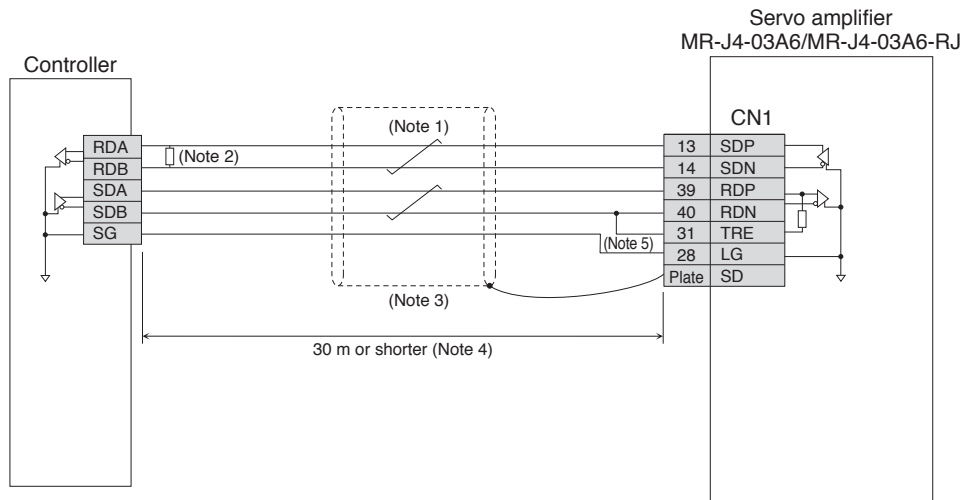

- Notes: 1. Twist the wires from SDP and SDN together, and RDP and PDN together.  
 2. Refer to the controller manual to connect a termination resistor. If a termination resistor is not specified, terminate with a 150 Ω resistor.  
 3. It is recommended that the cable be shielded.  
 4. The cable length must be 30 m or shorter in a low-noise environment. When connecting multiple axes, also keep the overall length within 30 m.  
 5. Connect TRE and RDN for the servo amplifier of the final axis.

**!** Be sure to read through Instruction Manual for the actual wiring and use. Use the equipment after you have a full knowledge of the equipment, safety information and instructions.

Servo Amplifiers  
 Rotary Servo Motors  
 Linear Servo Motors  
 Direct Drive Motors  
 Options/Peripheral Equipment  
 LVS/Wires  
 Product List  
 Precautions

# Servo Amplifiers

## Main/Control Circuit Power Supply Connection Example (for MR-J4-03A6/MR-J4-03A6-RJ)

A A-RJ

● For 48 V DC

● For 24 V DC

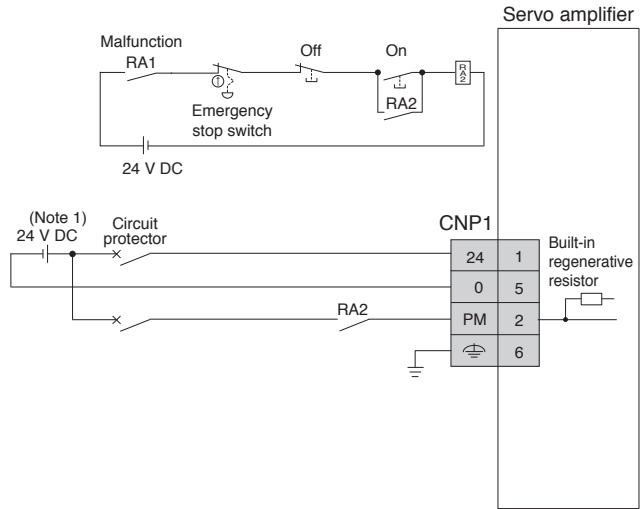
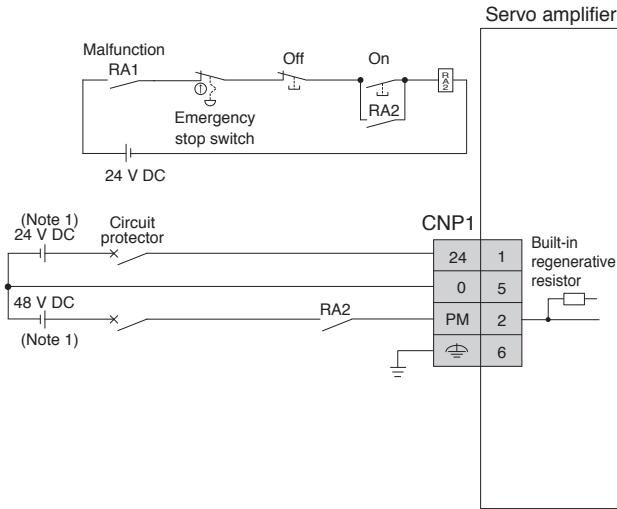

## Servo Motor Connection Example (for MR-J4-03A6/MR-J4-03A6-RJ)

A A-RJ

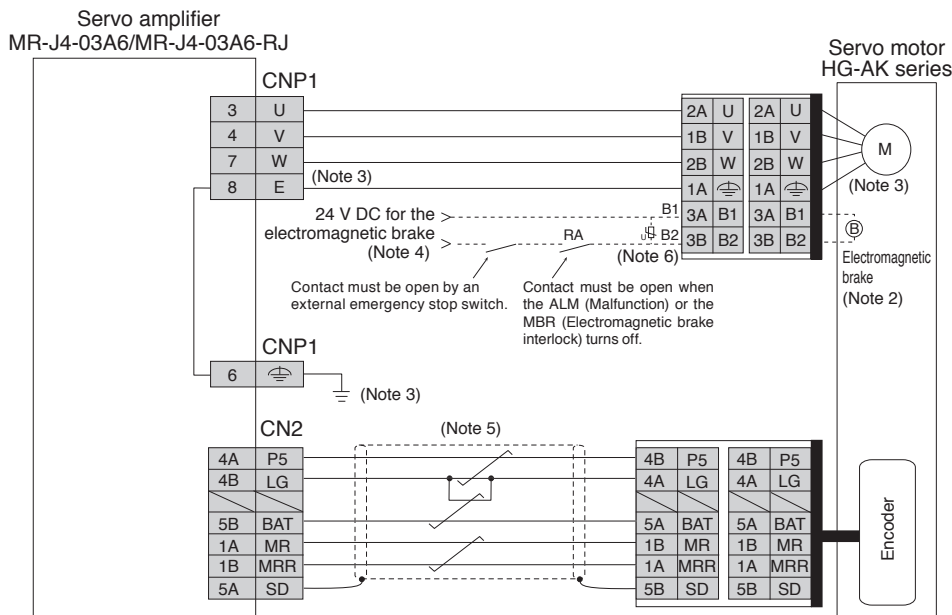

Notes: 1. Use 48 V DC and 24 V DC power supplies with reinforced insulation.

2. This is for the servo motor with electromagnetic brake. The electromagnetic brake terminals (B1, B2) do not have polarity.

3. Noiseless grounding (⏏) terminal is connected to E terminal in the servo amplifier. Connect the noiseless (⏏) terminal of CNP1 and the grounding terminal of the cabinet.

4. Do not use the 24 V DC interface power supply for the electromagnetic brake. Provide a dedicated power supply to the electromagnetic brake.

5. Encoder cable is available as an option. Refer to "Servo Motor Instruction Manual (Vol. 3)" when fabricating the cables.

6. Be sure to install a surge absorber between B1 and B2.



Be sure to read through Instruction Manual for the actual wiring and use. Use the equipment after you have a full knowledge of the equipment, safety information and instructions.

MR-J4-A/MR-J4-A-RJ Dimensions

- MR-J4-10A, MR-J4-10A-RJ, MR-J4-10A1, MR-J4-10A1-RJ
- MR-J4-20A, MR-J4-20A-RJ, MR-J4-20A1, MR-J4-20A1-RJ

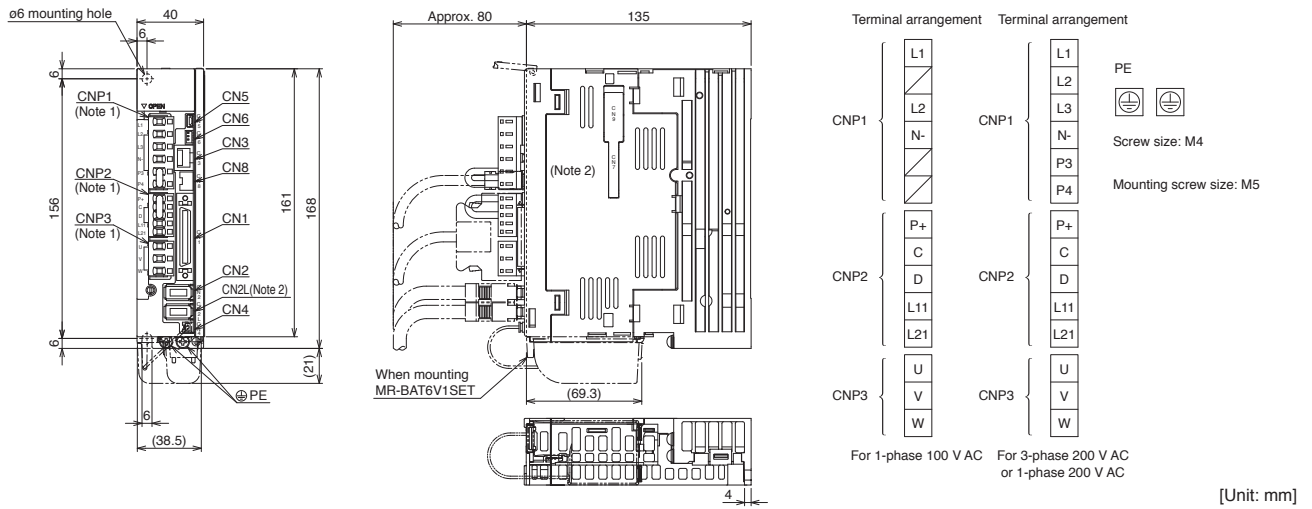

- MR-J4-40A, MR-J4-40A-RJ, MR-J4-40A1, MR-J4-40A1-RJ
- MR-J4-60A, MR-J4-60A-RJ

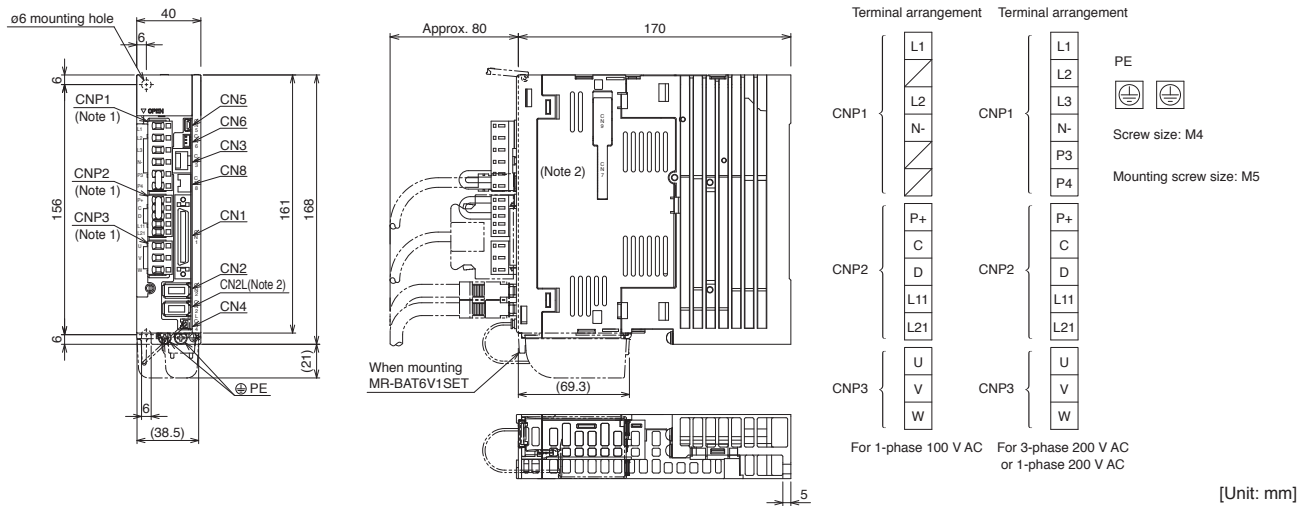

- MR-J4-70A, MR-J4-70A-RJ
- MR-J4-100A, MR-J4-100A-RJ

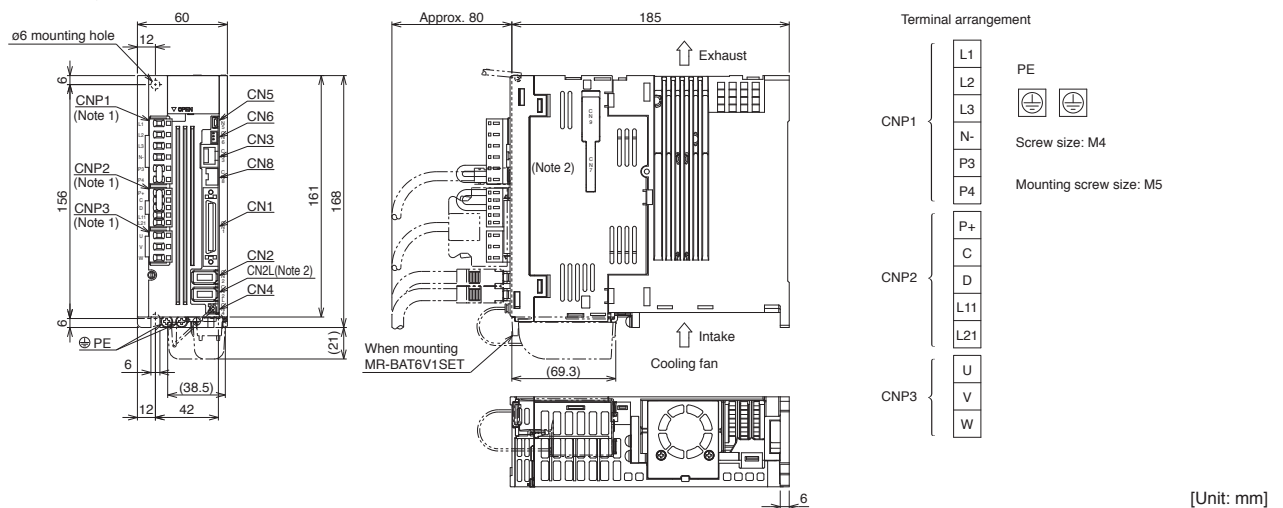

Notes: 1. CNP1, CNP2 and CNP3 connectors are supplied with the servo amplifier.  
2. CN2L, CN7, and CN9 connectors are not available for MR-J4-A servo amplifier. CN9 connector is available for use with MR-J4-A-RJ servo amplifiers manufactured in November 2014 or later.

# Servo Amplifiers

## MR-J4-A/MR-J4-A-RJ Dimensions

**A** **A-RJ**

- MR-J4-60A4, MR-J4-60A4-RJ
- MR-J4-100A4, MR-J4-100A4-RJ

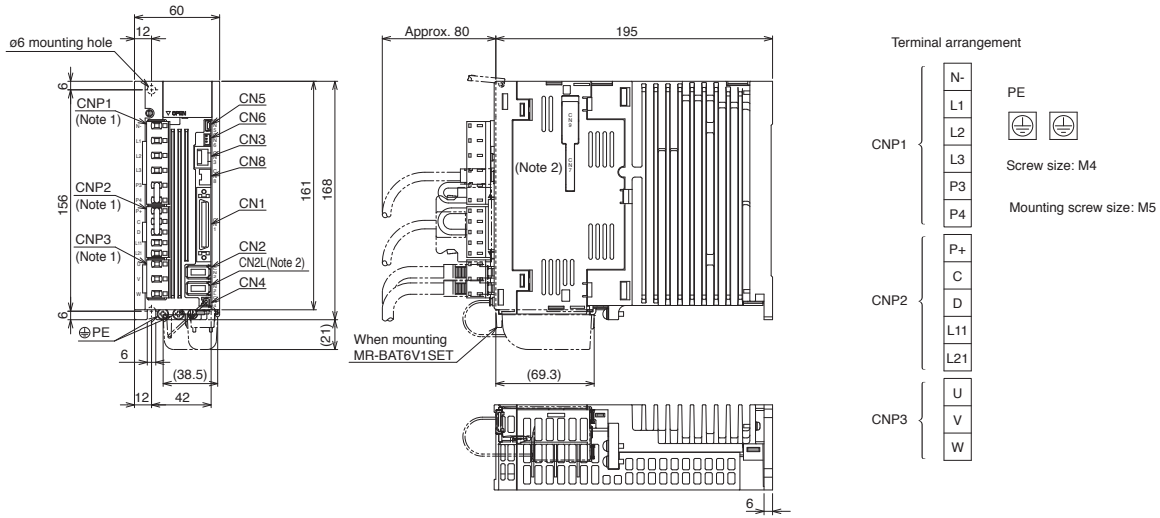

[Unit: mm]

## ● MR-J4-200A, MR-J4-200A-RJ

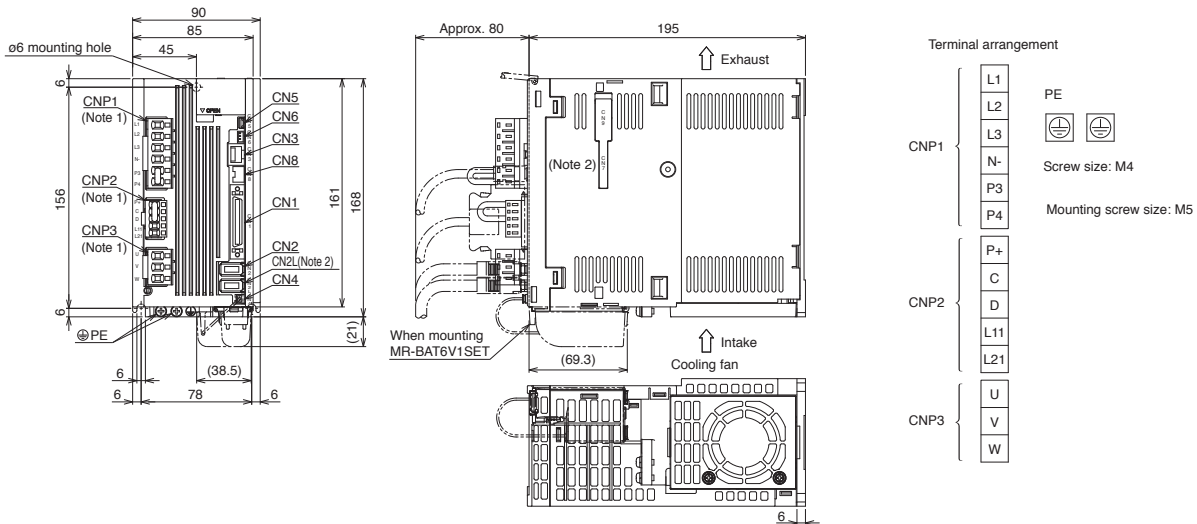

[Unit: mm]

## ● MR-J4-200A4, MR-J4-200A4-RJ

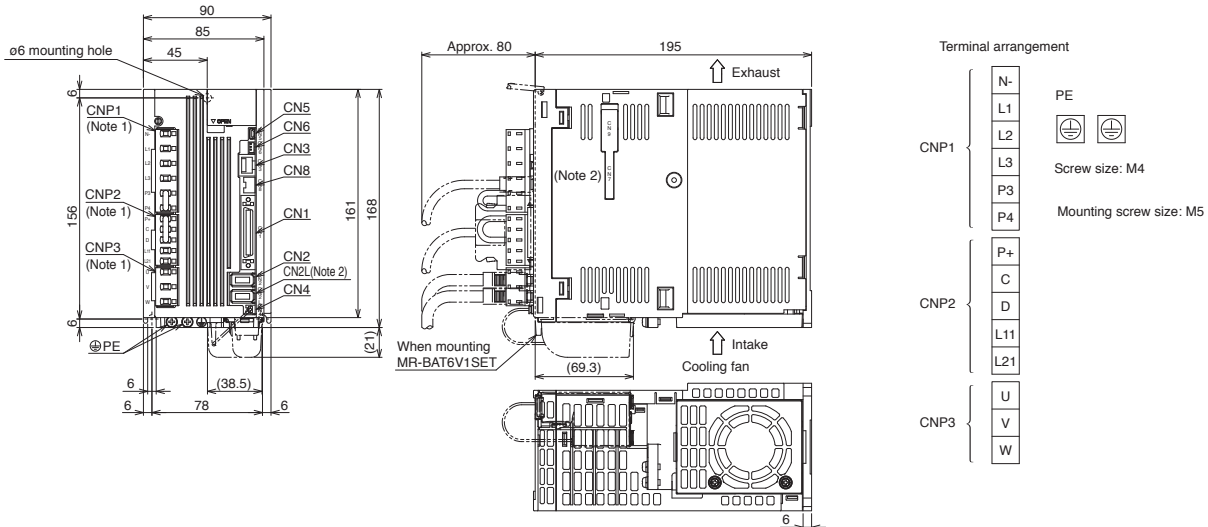

[Unit: mm]

Notes: 1. CNP1, CNP2 and CNP3 connectors are supplied with the servo amplifier.

2. CN2L, CN7, and CN9 connectors are not available for MR-J4-A servo amplifier. CN9 connector is available for use with MR-J4-A-RJ servo amplifiers manufactured in November 2014 or later.

MR-J4-A/MR-J4-A-RJ Dimensions

●MR-J4-350A, MR-J4-350A-RJ

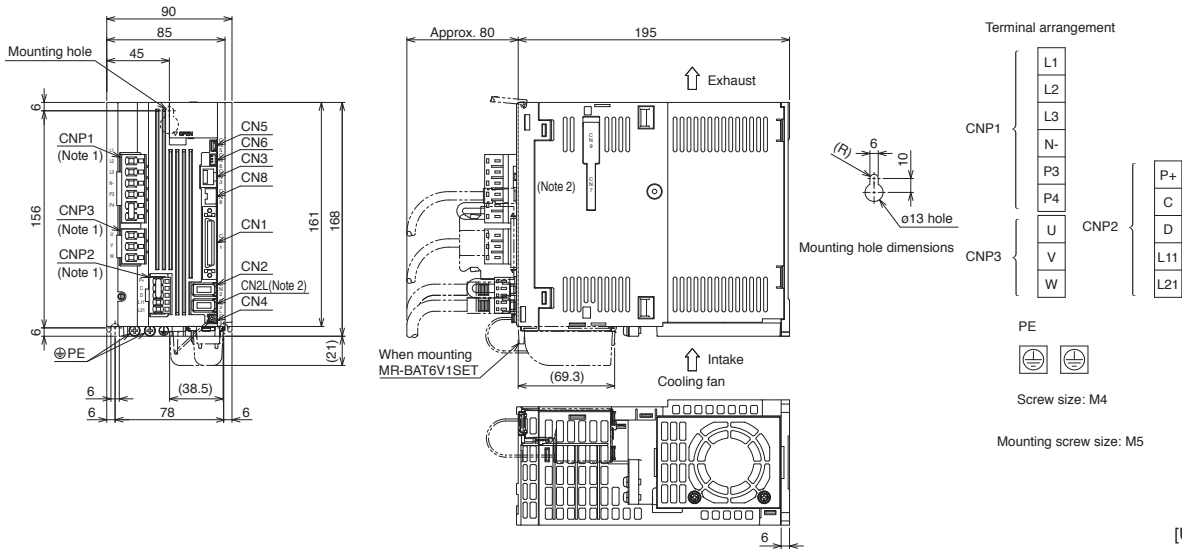

[Unit: mm]

●MR-J4-350A4, MR-J4-350A4-RJ

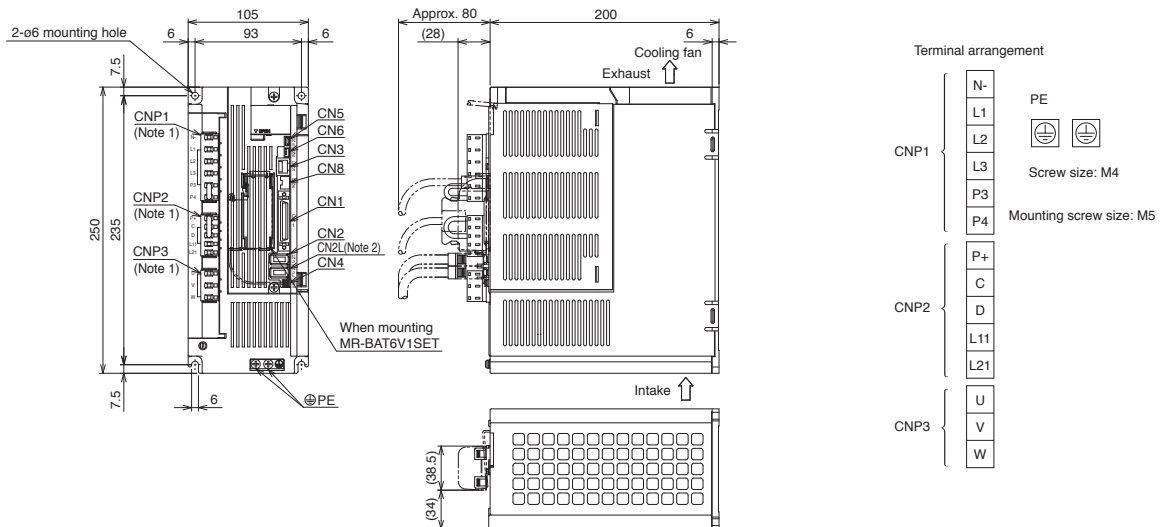

[Unit: mm]

●MR-J4-500A, MR-J4-500A-RJ

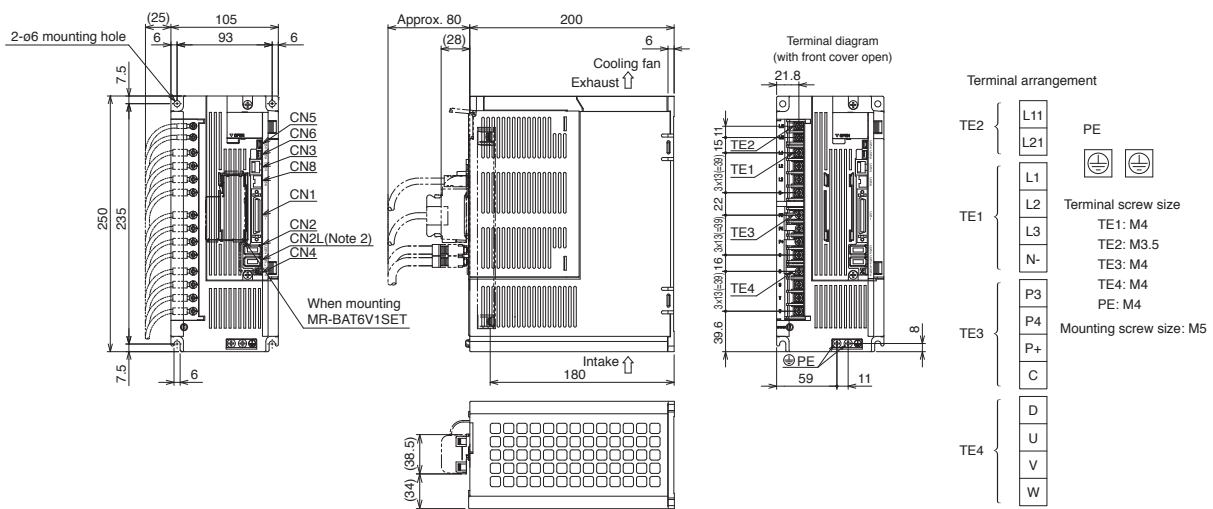

[Unit: mm]

Notes: 1. CNP1, CNP2 and CNP3 connectors are supplied with the servo amplifier.  
 2. CN2L, CN7, and CN9 connectors are not available for MR-J4-A servo amplifier. CN9 connector is available for use with MR-J4-A-RJ servo amplifiers manufactured in November 2014 or later.

# Servo Amplifiers

## MR-J4-A/MR-J4-A-RJ Dimensions

**A** **A-RJ**

### ●MR-J4-500A4, MR-J4-500A4-RJ

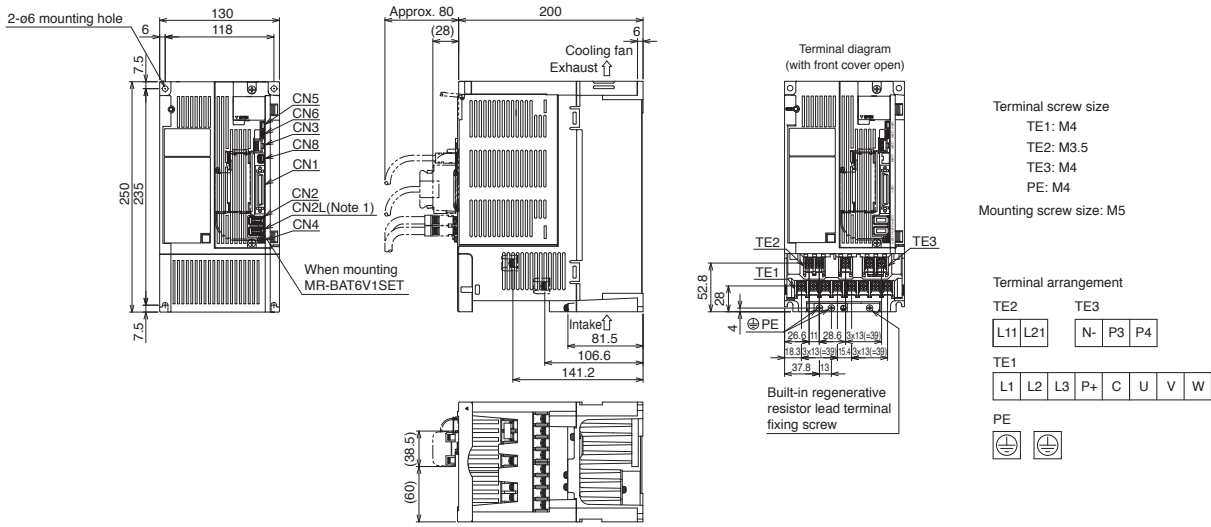

[Unit: mm]

### ●MR-J4-700A, MR-J4-700A-RJ, MR-J4-700A4, MR-J4-700A4-RJ

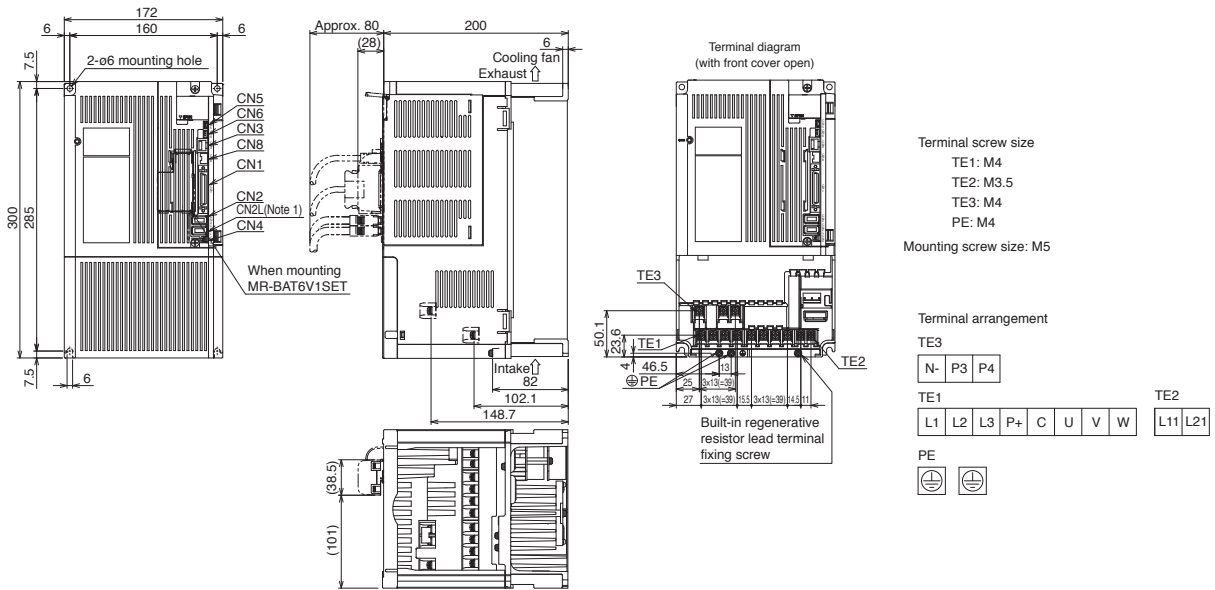

[Unit: mm]

Notes: 1. CN2L, CN7, and CN9 connectors are not available for MR-J4-A servo amplifier. CN9 connector is available for use with MR-J4-A-RJ servo amplifiers manufactured in November 2014 or later.



A A-RJ

MR-J4-A/MR-J4-A-RJ Dimensions

- MR-J4-11KA, MR-J4-11KA-RJ, MR-J4-11KA4, MR-J4-11KA4-RJ
- MR-J4-15KA, MR-J4-15KA-RJ, MR-J4-15KA4, MR-J4-15KA4-RJ

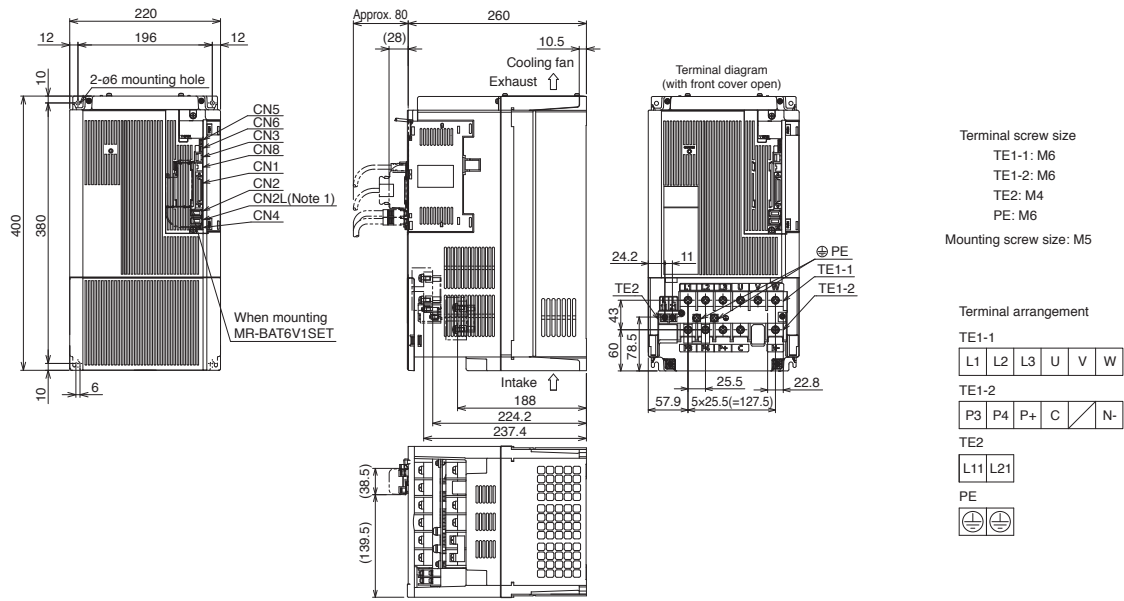

[Unit: mm]

- MR-J4-22KA, MR-J4-22KA-RJ, MR-J4-22KA4, MR-J4-22KA4-RJ

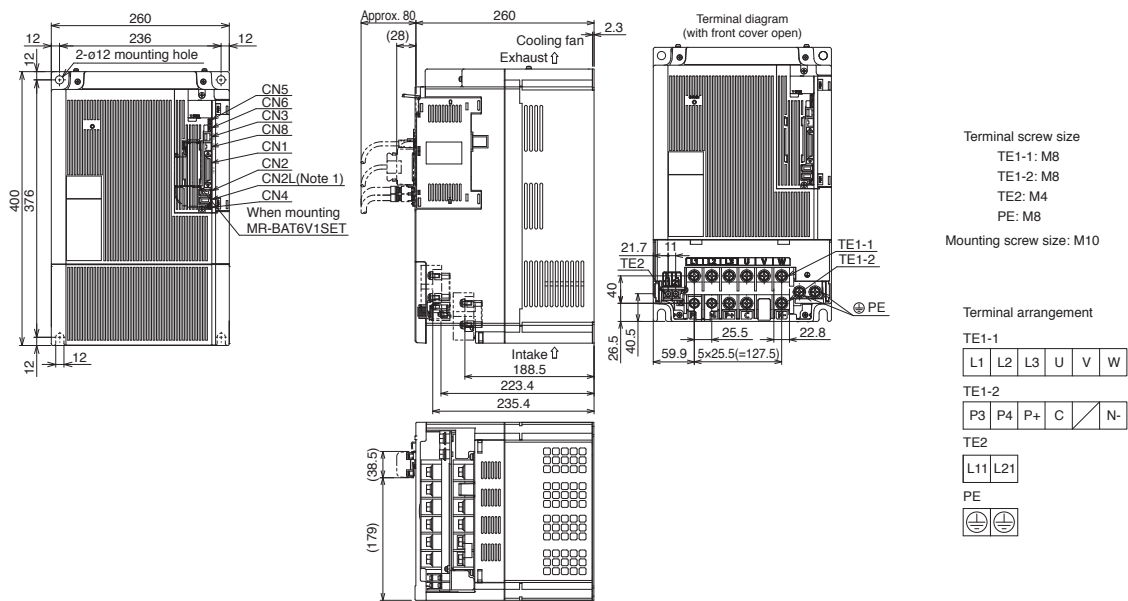

[Unit: mm]

Notes: 1. CN2L, CN7, and CN9 connectors are not available for MR-J4-A servo amplifier. CN9 connector is available for use with MR-J4-A-RJ servo amplifiers manufactured in November 2014 or later.

Servo Amplifiers

Rotary Servo Motors

Linear Servo Motors

Direct Drive Motors

Options/Peripheral Equipment

LVS/Wires

Product List

Precautions

# Servo Amplifiers

## MR-J4-DU\_A/MR-J4-DU\_A-RJ Dimensions (Note 1)

**A** **A-RJ**

- MR-J4-DU30KA, MR-J4-DU30KA-RJ    ● MR-J4-DU37KA, MR-J4-DU37KA-RJ
- MR-J4-DU45KA4, MR-J4-DU45KA4-RJ    ● MR-J4-DU55KA4, MR-J4-DU55KA4-RJ

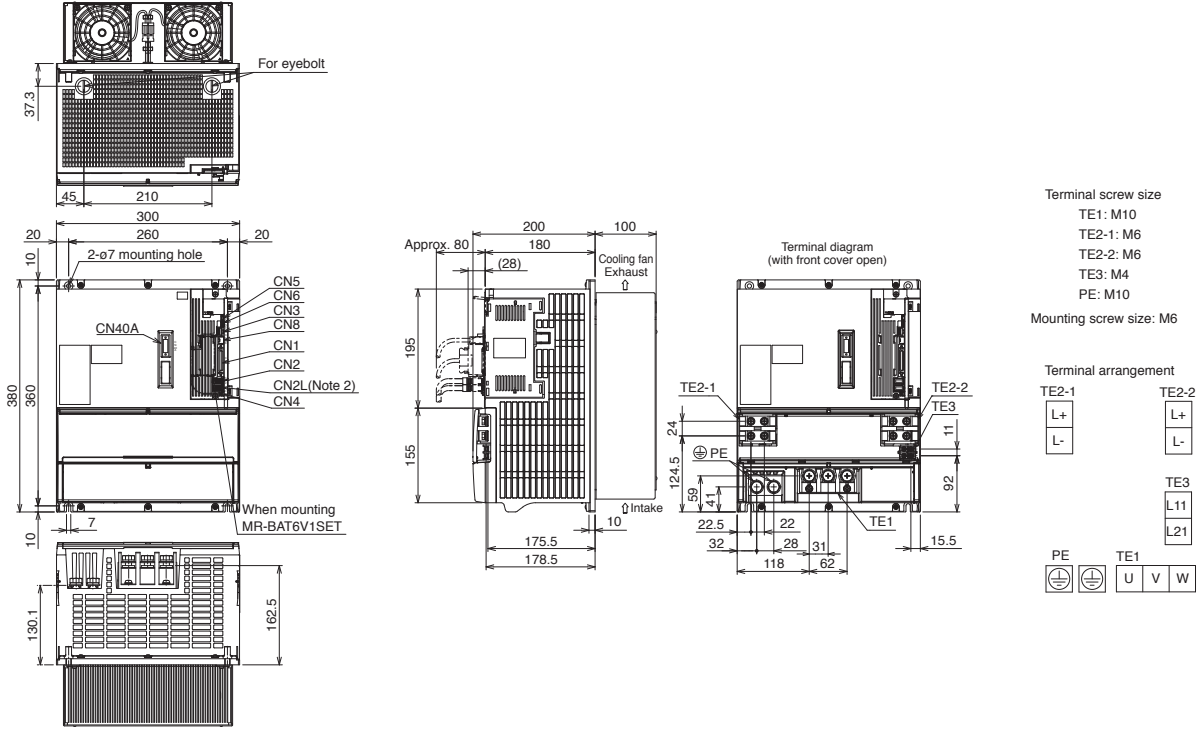

[Unit: mm]

- MR-J4-DU30KA4, MR-J4-DU30KA4-RJ    ● MR-J4-DU37KA4, MR-J4-DU37KA4-RJ

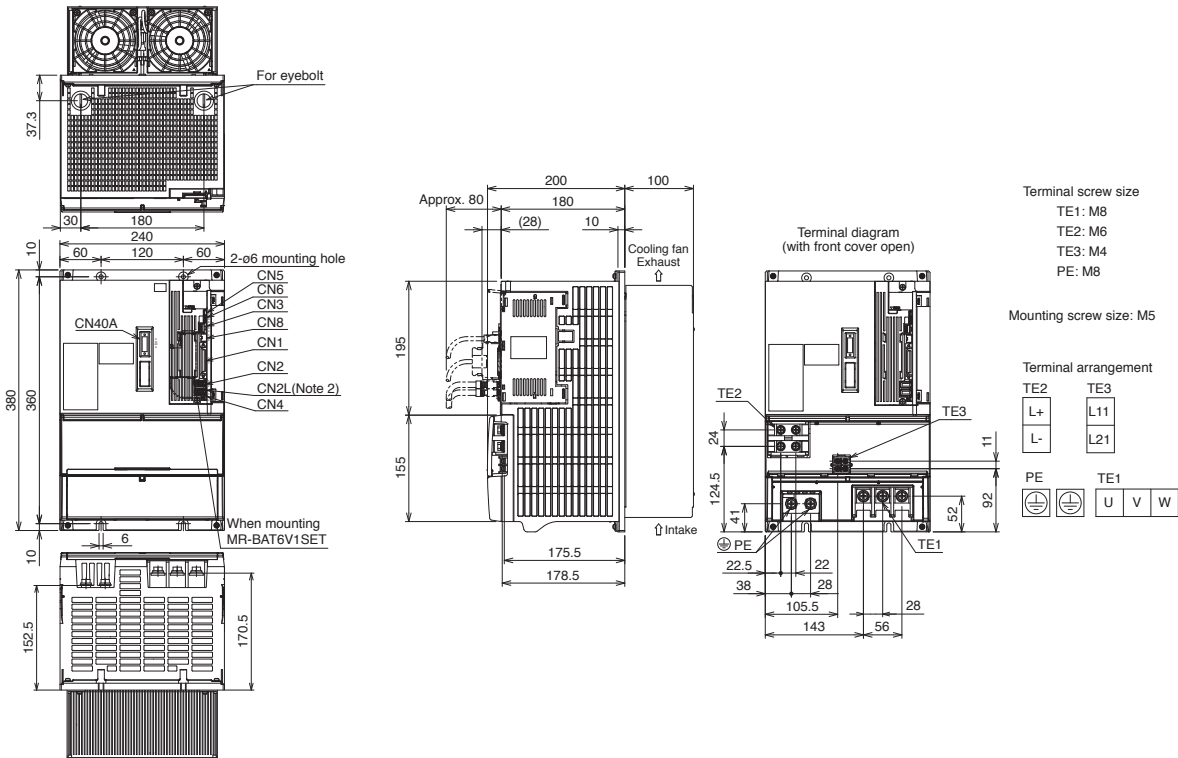

[Unit: mm]

Notes: 1. For the panel cut dimensions, refer to "Panel Cut Dimensions for Resistance Regeneration Converter Unit and Drive Unit" in this catalog.  
 2. CN2L, CN7, and CN9 connectors are not available for MR-J4-DU\_A\_ drive unit. CN9 connector is available for use with MR-J4-DU\_A\_-RJ drive unit manufactured in January 2015 or later.

MR-J4-03A6/MR-J4-03A6-RJ Dimensions

A A-RJ

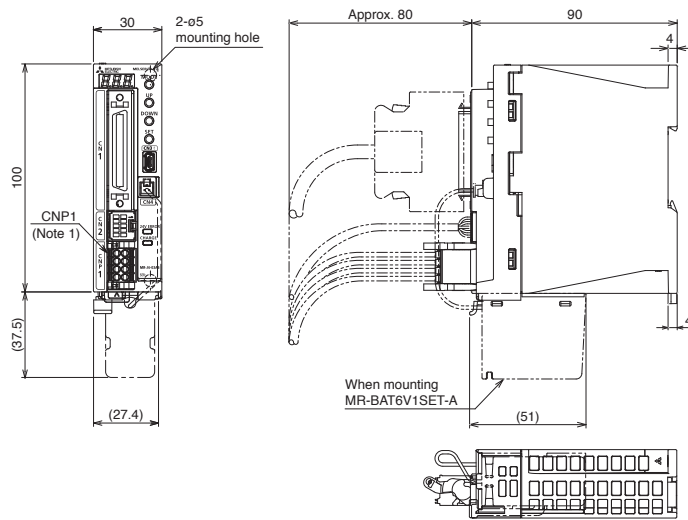

Terminal arrangement

CNP1			
5	0	24	1
6	PM		2
7	W	U	3
8	E	V	4

Mounting screw size: M4

[Unit: mm]

Notes: 1. CNP1 connector is supplied with the servo amplifier.

Servo Amplifiers

Rotary Servo Motors

Linear Servo Motors

Direct Drive Motors

Options/Peripheral Equipment

LVS/Wires

Product List

Precautions

## MR-J4-GF(-RJ)/MR-J4-A-RJ Positioning Function: Point Table Method

**GF** **GF-RJ** **A-RJ**

Set the position and speed data to the point table, and select the point table No. with the command interface signal to start the positioning operation.

Item		Description		
Command method	Command interface	MR-J4-_GF_(-RJ)	CC-Link IE Field Network communication	
		MR-J4-_A_-RJ	DI/O (Input: 11 points excluding EM2 (Forced stop 2), output: 8 points) RS-422/RS-485 communication <sup>(Note 3)</sup>	
		MR-J4-03A6-RJ	DI/O (Input: 11 points excluding EM2 (Forced stop 2), output: 6 points) RS-422 communication <sup>(Note 4)</sup>	
	Operating specification		Positioning by specifying the point table No. (255 points)	
	Position command input <sup>(Note 1)</sup>	Absolute value command method	Set in the point table. Setting range of feed length per point: -999999 to 999999 [ $\times 10^{\text{STM}}$ $\mu\text{m}$ ], -99.9999 to 99.9999 [ $\times 10^{\text{STM}}$ inch], -999999 to 999999 [pulse], Setting range of rotation angle: -360.000 to 360.000 [degree] <sup>(Note 2)</sup>	
		Incremental value command method	Set in the point table. Setting range of feed length per point: 0 to 999999 [ $\times 10^{\text{STM}}$ $\mu\text{m}$ ], 0 to 99.9999 [ $\times 10^{\text{STM}}$ inch], 0 to 999999 [pulse], Setting range of rotation angle: 0 to 999.999 [degree] <sup>(Note 2)</sup>	
	Speed command input	MR-J4-_GF_(-RJ)	Set the acceleration/deceleration time constants in the point table. Set the S-pattern acceleration/deceleration time constants with [Pr. PT51].	
		MR-J4-_A_-RJ	Set the acceleration/deceleration time constants in the point table. Set the S-pattern acceleration/deceleration time constants with [Pr. PC03].	
		MR-J4-03A6-RJ	Set the acceleration/deceleration time constants in the point table. Set the S-pattern acceleration/deceleration time constants with [Pr. PC03].	
	System		Signed absolute value command method, incremental value command method	
	Analog override <sup>(Note 2)</sup>		0 V DC to $\pm 10$ V DC/0% to 200%	
	Torque limit	MR-J4-_GF_(-RJ)	Set by parameters or link devices	
MR-J4-_A_-RJ		Set by parameters or external analog input (0 V DC to +10 V DC/maximum torque)		
MR-J4-03A6-RJ				
Operation mode	Automatic operation mode	One-time positioning operation	Point table No. input, position data input method One-time positioning operation is executed based on the position/speed commands.	
		Automatic continuous positioning operation	Varying-speed operation (2 to 255 speeds), automatic continuous positioning operation (2 to 255 points) automatic continuous operation to the point table selected at start, automatic continuous operation to the point table No. 1	
	Manual operation mode	JOG operation	MR-J4-_GF_(-RJ)	Inching operation is executed with a CC-Link IE Field Network communication function based on speed commands set with a parameter.
			MR-J4-_A_-RJ MR-J4-03A6-RJ	Inching operation is executed with input signal or serial communication function <sup>(Note 3)</sup> based on speed commands set with a parameter.
		Manual pulse generator operation <sup>(Note 2)</sup>	Manual feeding is executed with a manual pulse generator. Command pulse multiplication: select from $\times 1$ , $\times 10$ , and $\times 100$ with a parameter.	
	Home position return mode	MR-J4-_GF_-RJ	Dog type (rear end detection, Z-phase reference), stopper type (stopper position reference), count type (front end detection, Z-phase reference), dog type (rear end detection, rear end reference), count type (front end detection, front end reference), dog cradle type, dog type last Z-phase reference, dog type front end reference, dogless Z-phase reference, Home position ignorance (servo-on position as home position), Homing on positive home switch and index pulse (method 3, 4), Homing on negative home switch and index pulse (method 5, 6), Homing on home switch and index pulse (method 7, 8, 11, 12), Homing without index pulse (method 19, 20, 21, 22, 23, 24, 27, 28), Homing on index pulse (method 33, 34), Homing on current position (method 35, 37)	
		MR-J4-_A_-RJ MR-J4-03A6-RJ	Dog type, count type, data set type, stopper type, home position ignorance (servo-on position as home position), dog type rear end reference, count type front end reference, dog cradle type, dog type adjacent Z-phase reference, dog type front end reference, dogless Z-phase reference	
		Automatic positioning to home position function	High-speed automatic positioning to a defined home position	
	Other functions	MR-J4-_GF_-RJ	Absolute position detection, overtravel prevention with limit switches, software stroke limit, simple cam function	
		MR-J4-_A_-RJ MR-J4-03A6-RJ	Absolute position detection, backlash compensation, overtravel prevention with external limit switches (LSP/LSN), teaching function, roll feed display function, software stroke limit, mark detection (current position latch/interrupt positioning), simple cam function, infinite feed function (setting degree), analog override function	

Notes: 1. STM is the ratio to the setting value of the position data. STM can be changed with [Pr. PT03].

2. Supported by MR-J4-\_A\_-RJ and MR-J4-03A6-RJ.

3. Compatible with RS-422 communication (Mitsubishi Electric general-purpose AC servo protocol) and RS-485 communication (MODBUS<sup>®</sup> RTU protocol).

4. Compatible with RS-422 communication (Mitsubishi Electric general-purpose AC servo protocol).

MR-J4-GF(-RJ)/MR-J4-A-RJ Positioning Function: Point Table Method

GF GF-RJ A-RJ

Absolute value command method: travels to a specified address (absolute value) with reference to the home position

Item	Setting range	Description
Point table No.	1 to 255	Specify a point table in which a target position, servo motor speed, acceleration/deceleration time constants, dwell, and auxiliary function will be set.
Target position <sup>(Note 1, 3)</sup> (position data)	-999999 to 999999 [ $\times 10^{\text{STM}}$ $\mu\text{m}$ ] -99.9999 to 99.9999 [ $\times 10^{\text{STM}}$ inch] -360.000 to 360.000 [degree] <sup>(Note 4)</sup> -999999 to 999999 [pulse]	Set a travel distance. (1) When using as absolute value command method Set a target address (absolute value). (2) When using as incremental value command method Set a travel distance. Reverse rotation command is applied with a minus sign.
Servo motor speed <sup>(Note 2)</sup>	0 to permissible speed [r/min] [mm/s]	Set a command speed for the servo motor in positioning.
Acceleration time constant	0 to 20000 [ms]	Set a time period for the servo motor to reach the rated speed.
Deceleration time constant	0 to 20000 [ms]	Set a time period for the servo motor to decelerate from the rated speed to a stop.
Dwell	0 to 20000 [ms]	Set a dwell. When the dwell is set, the position command for the next point table will be started after the position command for the selected point table is completed and the set dwell is passed. The dwell is disabled when 0 or 2 is set for the auxiliary function. Continuous operation is enabled when 1, 3, 8, 9, 10, or 11 is set for the auxiliary function and when 0 is set for the dwell.
Auxiliary function	0 to 3, and 8 to 11	Set auxiliary function. (1) When using the point table with the absolute value command method 0: Automatic operation for a selected point table is performed. 1: Automatic continuous operation is performed without a stop to the next point table. 8: Automatic continuous operation is performed without a stop to the point table selected at startup. 9: Automatic continuous operation of the point table No. 1 is performed without a stop. (2) When using this point table with the incremental value command method 2: Automatic operation for a selected point table is performed. 3: Automatic continuous operation is performed without a stop to the next point table. 10: Automatic continuous operation for a point table selected at startup is performed. 11: Automatic continuous operation of the point table No. 1 is performed without a stop.
M code	0 to 99	Set a code to be outputted when the positioning completes.

- Notes: 1. Change the unit to  $\mu\text{m}/\text{inch}/\text{degree}/\text{pulse}$  with [Pr. PT01].  
 2. The speed unit is r/min for the rotary servo motors and the direct drive motors, and mm/s for the linear servo motors.  
 3. STM is the ratio to the setting value of the position data. STM can be changed with [Pr. PT03].  
 4. Supported by MR-J4-A-RJ and MR-J4-03A6-RJ.

Example of setting point table data

Point table No.	Target position (position data) [ $\times 10^{\text{STM}}$ $\mu\text{m}$ ] <sup>(Note 1)</sup>	Servo motor speed [r/min]	Acceleration time constant [ms]	Deceleration time constant [ms]	Dwell [ms]	Auxiliary function	M code <sup>(Note 2)</sup>
1	1000	2000	200	200	0	*	1
2	2000	1600	100	100	0	0	2
:	:	:	:	:	:	:	:
255	3000	3000	100	100	0	2	99

\* The operation of the next point table is set with the auxiliary function.

● When the auxiliary function is set to 0:  
Start signal is required for each point table.

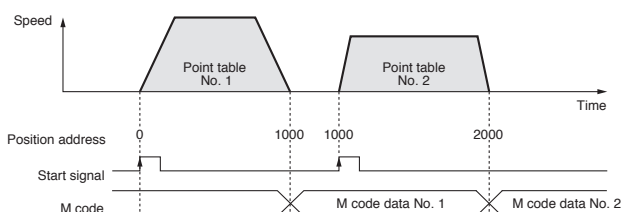

● When the auxiliary function is set to 1:  
Automatic continuous operation is executed based on the point table.

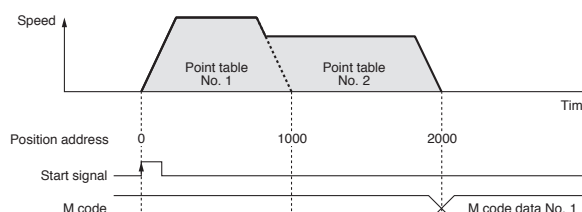

- Notes: 1. STM is the ratio to the setting value of the position data. STM can be changed with [Pr. PT03].  
 2. Supported by MR-J4-A-RJ and MR-J4-03A6-RJ.

## MR-J4-GF(-RJ)/MR-J4-A-RJ Positioning Function: Point Table Method

GF GF-RJ A-RJ

Incremental value command method: travels from a current position based on the set position data

Item	Setting range	Description
Point table No.	1 to 255	Specify a point table in which a target position, servo motor speed, acceleration/deceleration time constants, dwell, and auxiliary function will be set.
Target position (position data) <small>(Note 1, 3)</small>	0 to 999999 [ $\times 10^{\text{STM}}$ $\mu\text{m}$ ] 0 to 99.9999 [ $\times 10^{\text{STM}}$ inch] 0 to 999.999 [degree] <small>(Note 4)</small> 0 to 999999 [pulse]	Set a travel distance. Operation starts with ST1 (Forward rotation start) or ST2 (Reverse rotation start).
Servo motor speed <small>(Note 2)</small>	0 to permissible speed [r/min] [mm/s]	Set a command speed for the servo motor in positioning.
Acceleration time constant	0 to 20000 [ms]	Set a time period for the servo motor to reach the rated speed.
Deceleration time constant	0 to 20000 [ms]	Set a time period for the servo motor to decelerate from the rated speed to a stop.
Dwell	0 to 20000 [ms]	Set a dwell. When the dwell is set, the position command for the next point table will be started after the position command for the selected point table is completed and the set dwell is passed. The dwell is disabled when 0 is set for the auxiliary function. Continuous operation is enabled when 1, 8, or 9 is set for the auxiliary function and when 0 is set for the dwell.
Auxiliary function	0, 1, 8, and 9	Set auxiliary function. 0: Automatic operation for a selected point table is performed. 1: Automatic continuous operation is performed without a stop to the next point table. 8: Automatic continuous operation is performed without a stop to the point table selected at startup. 9: Automatic continuous operation of the point table No. 1 is performed without a stop.
M code	0 to 99	Set a code to be outputted when the positioning completes.

- Notes: 1. Change the unit to  $\mu\text{m}/\text{inch}/\text{degree}/\text{pulse}$  with [Pr. PT01].  
2. The speed unit is r/min for the rotary servo motors and the direct drive motors, and mm/s for the linear servo motors.  
3. STM is the ratio to the setting value of the position data. STM can be changed with [Pr. PT03].  
4. Supported by MR-J4-\_A\_-RJ and MR-J4-03A6-RJ.

### Example of setting point table data

Point table No.	Target position (position data) [ $\times 10^{\text{STM}}$ $\mu\text{m}$ ] <small>(Note 1)</small>	Servo motor speed [r/min]	Acceleration time constant [ms]	Deceleration time constant [ms]	Dwell [ms]	Auxiliary function	M code <small>(Note 2)</small>
1	1000	2000	200	200	0	*	1
2	1000	1600	100	100	0	0	2
:	:	:	:	:	:	:	:
255	3000	3000	100	100	0	0	99

\* The operation of the next point table is set with the auxiliary function.

- When the auxiliary function is set to 0:  
Start signal is required for each point table.

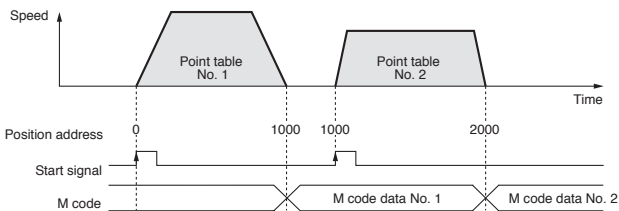

- When the auxiliary function is set to 1:  
Automatic continuous operation is executed based on the point table.

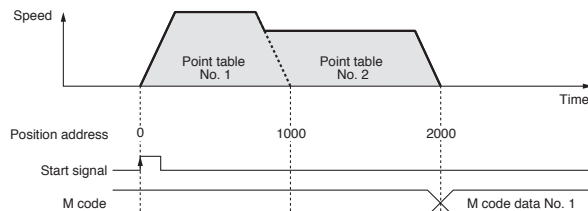

- Notes: 1. STM is the ratio to the setting value of the position data. STM can be changed with [Pr. PT03].  
2. Supported by MR-J4-\_A\_-RJ and MR-J4-03A6-RJ.

MR-J4-A-RJ Standard Wiring Diagram Example: Point Table Method

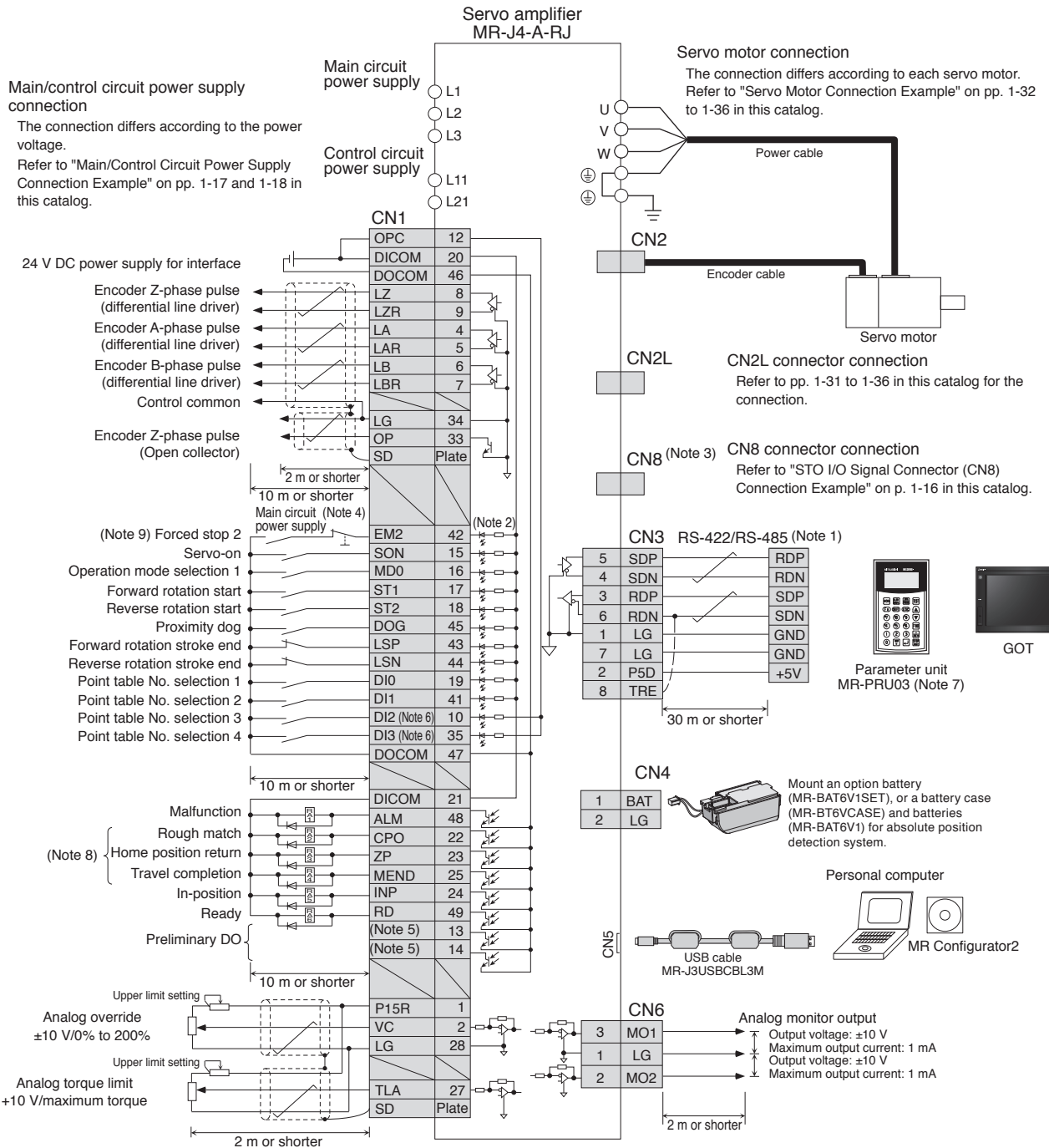

- Notes: 1. It is also possible to connect a personal computer to CN3 connector with an RS-422/RS-232C conversion cable. However, USB (CN5 connector) and RS-422/RS-485 (CN3 connector) communication functions are mutually exclusive. Do not use them at the same time. Refer to "Products on the Market for Servo Amplifiers" in this catalog for the RS-422/RS-232C conversion cable.
2. This is for sink wiring. Source wiring is also possible. However, when input devices are assigned to CN1-10 pin and CN1-35 pin, be sure to use sink wiring. Source wiring is not possible in this case. In positioning mode, input devices are assigned in the initial setting. Refer to "MR-J4- \_A- \_RJ MR-J4-03A6-RJ Servo Amplifier Instruction Manual (Positioning Mode)" for details.
3. Be sure to attach a short-circuit connector supplied with the servo amplifier when the STO function is not used.
4. To prevent an unexpected restart of the servo amplifier, create a circuit to turn off EM2 (Forced stop 2) when the main circuit power is turned off.
5. No output device is assigned in the initial setting. Assign an output device with [Pr. PD47] as necessary.
6. DI2 and DI3 are assigned to CN1-10 pin and CN1-35 pin respectively in the initial setting. Change them with [Pr. PD44] and [Pr. PD46] when using a manual pulse generator.
7. When using MR-PRU03 parameter unit, use a commercial LAN cable (EIA568 compliant), and keep the wire length to a maximum of 10 m.
8. Assign the output devices mentioned to CN1-22 pin, CN1-23 pin, and CN1-25 pin with [Pr. PD23], [Pr. PD24] and [Pr. PD26].
9. The forced stop signal is issued for the servo amplifier. For overall system, apply the emergency stop on the controller side.



Be sure to read through Instruction Manual for the actual wiring and use. Use the equipment after you have a full knowledge of the equipment, safety information and instructions.

## MR-J4-03A6-RJ Standard Wiring Diagram Example: Point Table Method

A-RJ

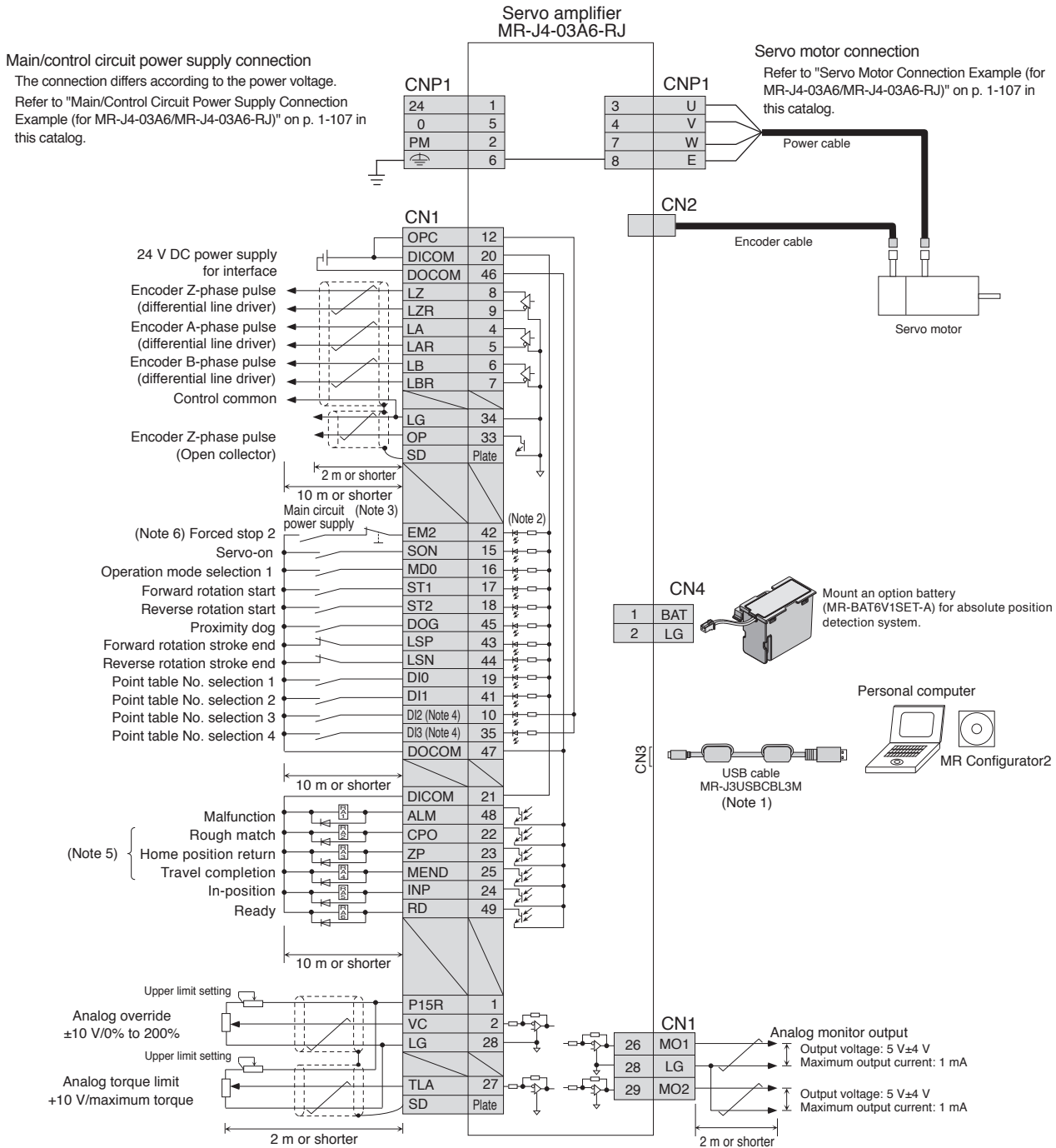

- Notes:
1. USB and RS-422 communication functions are mutually exclusive. Do not use them at the same time.
  2. This is for sink wiring. Source wiring is also possible. However, when input devices are assigned to CN1-10 pin and CN1-35 pin, be sure to use sink wiring. Source wiring is not possible in this case. In positioning mode, input devices are assigned in the initial setting. Refer to "MR-J4- A- RJ MR-J4-03A6-RJ Servo Amplifier Instruction Manual (Positioning Mode)" for details.
  3. To prevent an unexpected restart of the servo amplifier, create a circuit to turn off EM2 (Forced stop 2) when the main circuit power is turned off.
  4. DI2 and DI3 are assigned to CN1-10 pin and CN1-35 pin respectively in the initial setting. Change them with [Pr. PD44] and [Pr. PD46] when using a manual pulse generator.
  5. Assign the output devices mentioned to CN1-22 pin, CN1-23 pin, and CN1-25 pin with [Pr. PD23], [Pr. PD24] and [Pr. PD26].
  6. The forced stop signal is issued for the servo amplifier. For overall system, apply the emergency stop on the controller side.



Be sure to read through Instruction Manual for the actual wiring and use. Use the equipment after you have a full knowledge of the equipment, safety information and instructions.



### MR-J4-A-RJ Positioning Function: Program Method

Create a program including the position data, the servo motor speed, and the acceleration/deceleration time constants, and select the program No. with the command interface signals to start the positioning operation. The program based method enables more complex positioning operation than the point table method. MR Configurator2 is required to create programs.

Item		Description	
Command method	Command interface	MR-J4-_A_-RJ	DI/O (Input: 11 points excluding EM2 (Forced stop 2), output: 8 points) RS-422/RS-485 communication <sup>(Note 2)</sup>
		MR-J4-03A6-RJ	DI/O (Input: 11 points excluding EM2 (Forced stop 2), output: 6 points) RS-422 communication <sup>(Note 3)</sup>
	Operating specification		Program language (program with MR Configurator2) Program capacity: 640 steps (256 programs)
	Position command input <sup>(Note 1)</sup>	Absolute value command method	Set with program language. Setting range of feed length: -999999 to 999999 [ $\times 10^{\text{STM}}$ $\mu\text{m}$ ], -99.9999 to 99.9999 [ $\times 10^{\text{STM}}$ inch], -999999 to 999999 [pulse], Setting range of rotation angle: -360.000 to 360.000 [degree]
		Incremental value command method	Set with program language. Setting range of feed length: -999999 to 999999 [ $\times 10^{\text{STM}}$ $\mu\text{m}$ ], -99.9999 to 99.9999 [ $\times 10^{\text{STM}}$ inch], -999999 to 999999 [pulse], Setting range of rotation angle: -999.999 to 999.999 [degree]
	Speed command input		Set servo motor speed, acceleration/deceleration time constants, S-pattern acceleration/deceleration time constants with program language. S-pattern acceleration/deceleration time constants are also settable with [Pr. PC03].
	System		Signed absolute value command method/signed incremental value command method
	Analog override		0 V DC to $\pm 10$ V DC/0% to 200%
	Torque limit		Set by parameters or external analog input (0 V DC to +10 V DC/maximum torque)
Operation mode	Automatic operation mode	Program	Depends on the setting of the program language
	Manual operation mode	JOG operation	Inching operation is executed with input signal or serial communication function <sup>(Note 2)</sup> based on speed commands set with a parameter.
		Manual pulse generator operation	Manual feeding is executed with a manual pulse generator. Command pulse multiplication: select from $\times 1$ , $\times 10$ , and $\times 100$ with a parameter.
Home position return mode		Dog type, count type, data set type, stopper type, home position ignorance (servo-on position as home position), dog type rear end reference, count type front end reference, dog cradle type, dog type adjacent Z-phase reference, dog type front end reference, dogless Z-phase reference	
Other functions		Absolute position detection, backlash compensation, overtravel prevention with external limit switches (LSP/LSN), roll feed display function, software stroke limit, mark detection (current position latch/interrupt positioning/mark sensor input compensation), simple cam function, infinite feed function (setting degree), analog override function	

Notes: 1. STM is the ratio to the setting value of the position data. STM can be changed with [Pr. PT03].  
 2. Compatible with RS-422 communication (Mitsubishi Electric general-purpose AC servo protocol) and RS-485 communication (MODBUS® RTU protocol).  
 3. Compatible with RS-422 communication (Mitsubishi Electric general-purpose AC servo protocol).

## MR-J4-A-RJ Positioning Function: Program Method

A-RJ

### Command List

Command	Name	Setting range	Description
SPN(setting value) (Note 2)	Servo motor speed	0 to instantaneous permissible speed [r/min] [mm/s]	Set a command speed for the servo motor in positioning. Do not set a value exceeding the instantaneous permissible speed of the servo motor.
STA(setting value) (Note 2)	Acceleration time constant	0 to 20000 [ms]	Set acceleration time constant. The setting value is a time period that the servo motor reaches the rated speed from a stop.
STB(setting value) (Note 2)	Deceleration time constant	0 to 20000 [ms]	Set deceleration time constant. The setting value is a time period that the servo motor stops from the rated speed.
STC(setting value) (Note 2)	Acceleration/ deceleration time constants	0 to 20000 [ms]	Set acceleration and deceleration time constants. The setting value is a time period that the servo motor reaches the rated speed from a stop and stops from the rated speed.
STD(setting value) (Note 2)	S-pattern acceleration/ deceleration time constants	0 to 1000 [ms]	Set S-pattern acceleration/deceleration time constants.
MOV(setting value) (Note 4, 5)	Absolute value travel command	-999999 to 999999 [ $\times 10^{\text{STM}}$ $\mu\text{m}$ ] -99.9999 to 99.9999 [ $\times 10^{\text{STM}}$ inch]	Travels based on the value set as an absolute value.
MOVA(setting value) (Note 4, 5)	Absolute value continuous travel command	-360.000 to 360.000 [degree] -999999 to 999999 [pulse]	Travels continuously based on the value set as an absolute value. Be sure to write this command after [MOV] command.
MOVI(setting value) (Note 4, 5)	Incremental value travel command	-999999 to 999999 [ $\times 10^{\text{STM}}$ $\mu\text{m}$ ] -99.9999 to 99.9999 [ $\times 10^{\text{STM}}$ inch]	Travels based on the value set as an incremental value.
MOVIA(setting value) (Note 4, 5)	Incremental value continuous travel command	-999.999 to 999.999 [degree] -999999 to 999999 [pulse]	Travels continuously based on the value set as an incremental value. Be sure to write this command after [MOVI] command.
SYNC(setting value) (Note 1)	Waiting for external signal to switch on	1 to 3	Stops the next step until PI1 (Program input 1) to PI3 (Program input 3) turn on after SOUT (SYNC synchronous output) is outputted.
OUTON(setting value) (Note 1)	External signal on output	1 to 3	Turns on OUT1 (Program output 1) to OUT3 (Program output 3).
OUTOF(setting value) (Note 1)	External signal off output	1 to 3	Turns off OUT1 (Program output 1) to OUT3 (Program output 3) which were turned on with [OUTON] command.
TRIP(setting value) (Note 1, 4, 5)	Absolute value trip point specification	-999999 to 999999 [ $\times 10^{\text{STM}}$ $\mu\text{m}$ ] -99.9999 to 99.9999 [ $\times 10^{\text{STM}}$ inch] -360.000 to 360.000 [degree] -999999 to 999999 [pulse]	Executes the next step after [MOV] or [MOVA] commands are started and then the servo motor moves for the travel amount set in [TRIP] command. Be sure to write this command after [MOV] or [MOVA] command.
TRIP1(setting value) (Note 1, 4, 5)	Incremental value trip point specification	-999999 to 999999 [ $\times 10^{\text{STM}}$ $\mu\text{m}$ ] -99.9999 to 99.9999 [ $\times 10^{\text{STM}}$ inch] -999.999 to 999.999 [degree] -999999 to 999999 [pulse]	Executes the next step after [MOVI] or [MOVIA] commands are started and then the servo motor moves for the travel amount set in [TRIP1] command. Be sure to write this command after [MOVI] or [MOVIA] command.
ITP(setting value) (Note 1, 3, 4, 5)	Interrupt positioning	0 to 999999 [ $\times 10^{\text{STM}}$ $\mu\text{m}$ ] 0 to 99.9999 [ $\times 10^{\text{STM}}$ inch] 0 to 999.999 [degree] 0 to 999999 [pulse]	Stops the operation after the servo motor moves for the travel amount set when the interrupt signal is inputted. Be sure to write this command after [SYNC] command.
COUNT(setting value) (Note 1)	External pulse count	-999999 to 999999 [pulse]	Executes the next step when the value of the pulse counter exceeds the count value set in [COUNT] command. [COUNT (0)] clears the pulse counter to zero.
FOR(setting value) NEXT	Step repeat command	0, and 1 to 10000 [number of times]	Repeats the steps between [FOR(setting value)] and [NEXT] commands for the number of times set. Repeats endlessly with [FOR(0) NEXT].
LPOS (Note 1)	Current position latch	-	Latches the current position with the rising edge of the LPS signal. The latched current position data can be read with the communication command.
TIM(setting value)	Dwell	1 to 20000 [ms]	Waits for the next step until the set time passes.
ZRT	Home position return	-	Executes a manual home position return.
TIMES(setting value)	Program count command	0, and 1 to 10000 [number of times]	Set the number of program execution by writing [TIMES (setting value)] command in the first line of the program. The setting is not required for executing once. Repeats endlessly with [TIMES(0)].
STOP	Program stop	-	Stops the program in execution. Be sure to write this command in the final line.

Notes: 1. [SYNC], [OUTON], [OUTOF], [TRIP], [TRIP1], [ITP], [COUNT], and [LPOS] commands are valid while the commands are outputted.

2. [SPN] command is valid while [MOV], [MOVA], [MOVI], or [MOVIA] command is in execution. [STA], [STB], [STC], and [STD] commands are valid while [MOV] or [MOVI] command is in execution.

3. [ITP] command will be skipped to the next step when the remaining distance equals to or less than the setting value, when the servo motor is not running, or when the servo motor is decelerating.

4. Change the unit to  $\mu\text{m}/\text{inch}/\text{degree}/\text{pulse}$  with [Pr. PT01].

5. STM is the ratio to the setting value of the position data. STM can be changed with [Pr. PT03].

MR-J4-A-RJ Positioning Function: Program Method

A-RJ

Servo Amplifiers

Rotary Servo Motors

Linear Servo Motors

Direct Drive Motors

Options/Peripheral Equipment

LVS/Wires

Product List

Precautions

Command list

Command	Name	Setting range	Description
TLP(setting value)	Forward rotation torque limit	0, and 1 to 1000 [0.1%]	Limits the torque generated by the servo motor running in CCW and regenerating in CW, as the maximum torque is 100%. The setting remains valid until the program is stopped. [TLP(0)] enables the setting of [Pr. PA11].
TLN(setting value)	Reverse rotation torque limit	0, and 1 to 1000 [0.1%]	Limits the torque generated by the servo motor running in CW and regenerating in CCW, as the maximum torque is 100%. The setting remains valid until the program is stopped. [TLN(0)] enables the setting of [Pr. PA12].
TQL(setting value)	Torque limit	0, and 1 to 1000 [0.1%]	Limits the torque generated by the servo motor, as the maximum torque is 100%. The setting remains valid until the program is stopped. [TQL(0)] enables the settings of [Pr. PA11] and [Pr. PA12].

Program example 1

The following is an example of executing two types of operations with the same servo motor speed and acceleration/deceleration time constants but the different travel commands.

Step	Program (Note 1)	Description
(1)	SPN(3000)	Servo motor speed: 3000 [r/min]
(2)	STA(200)	Acceleration time constant: 200 [ms]
(3)	STB(300)	Deceleration time constant: 300 [ms]
(4)	MOV(1000)	Absolute value travel command: 1000 [ $\times 10^{STM} \mu\text{m}$ ]
(5)	TIM(100)	Dwell: 100 [ms]
(6)	MOV(2500)	Absolute value travel command: 2500 [ $\times 10^{STM} \mu\text{m}$ ]
(7)	STOP	Program stop

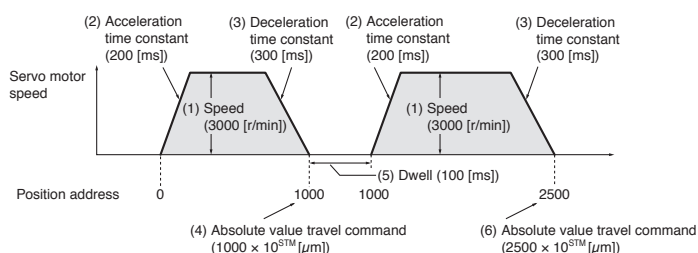

Program example 2

The following is an example of repeating the steps between [FOR(setting value)] and [NEXT] commands for the number of times set.

Step	Program (Note 1)	Description
(1)	SPN(3000)	Servo motor speed: 3000 [r/min]
(2)	STC(20)	Acceleration/deceleration time constants: 20 [ms]
(3)	MOV(1000)	Absolute value travel command: 1000 [ $\times 10^{STM} \mu\text{m}$ ]
(4)	TIM(100)	Dwell: 100 [ms]
(5)	FOR(3)	Starting the step repeat command: 3 [number of times]
(6)	MOVI(100)	Incremental value travel command: 100 [ $\times 10^{STM} \mu\text{m}$ ]
(7)	TIM(100)	Dwell: 100 [ms]
(8)	NEXT	Ending the step repeat command
(9)	STOP	Program stop

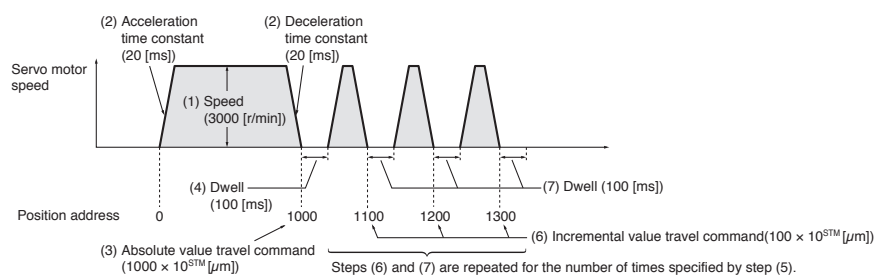

Notes: 1. The values in [SPN], [STA], [STB], and [STC] commands remains valid until they are reset. The values will not be initialized at the start of the program. The settings are also valid in other programs.

## MR-J4-A-RJ Standard Wiring Diagram Example: Program Method

A-RJ

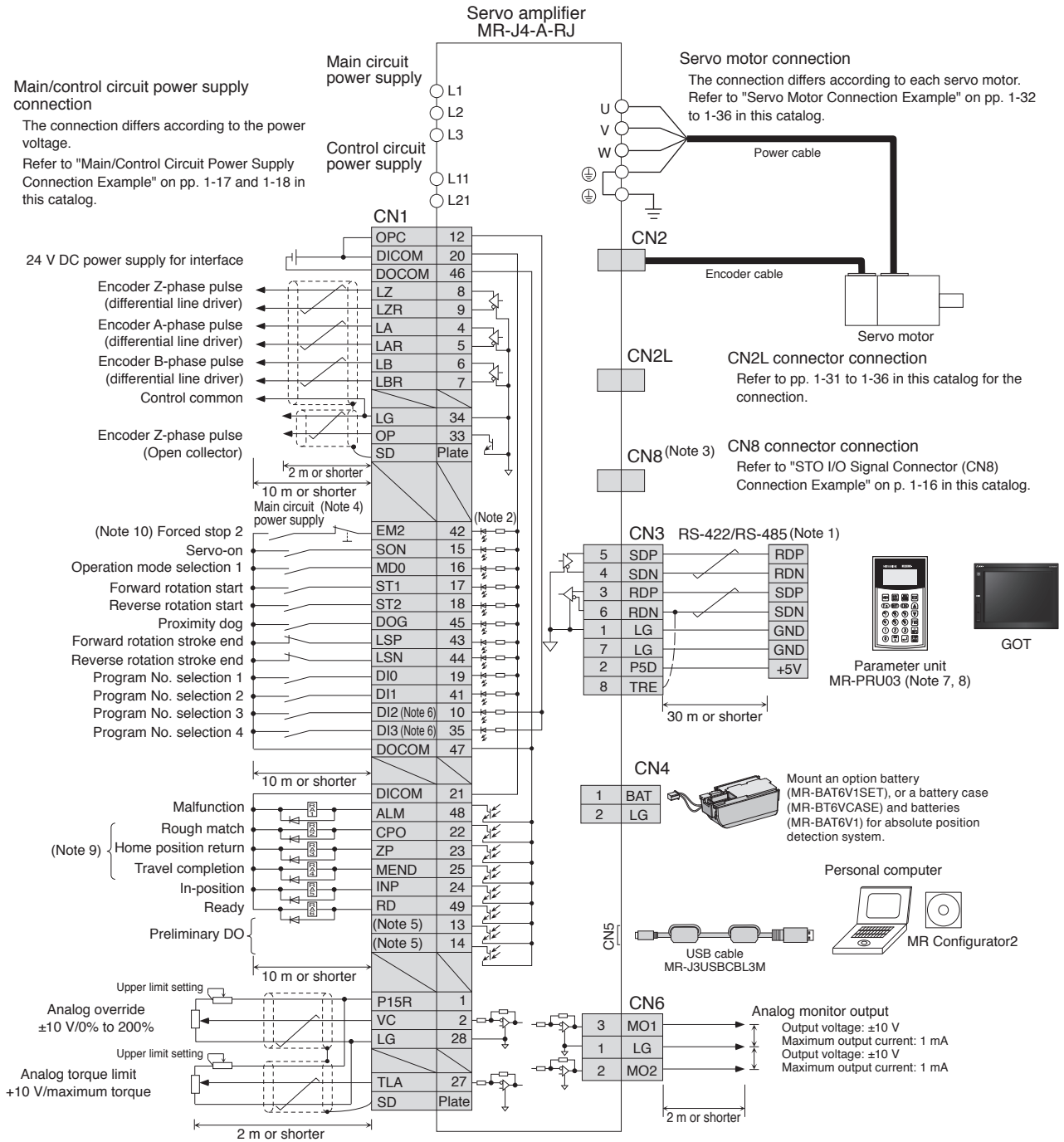

- Notes:
- It is also possible to connect a personal computer to CN3 connector with an RS-422/RS-232C conversion cable. However, USB (CN5 connector) and RS-422/RS-485 (CN3 connector) communication functions are mutually exclusive. Do not use them at the same time. Refer to "Products on the Market for Servo Amplifiers" in this catalog for the RS-422/RS-232C conversion cable.
  - This is for sink wiring. Source wiring is also possible. However, when input devices are assigned to CN1-10 pin and CN1-35 pin, be sure to use sink wiring. Source wiring is not possible in this case. In positioning mode, input devices are assigned in the initial setting. Refer to "MR-J4\_A\_RJ MR-J4-03A6-RJ Servo Amplifier Instruction Manual (Positioning Mode)" for details.
  - Be sure to attach a short-circuit connector supplied with the servo amplifier when the STO function is not used.
  - To prevent an unexpected restart of the servo amplifier, create a circuit to turn off EM2 (Forced stop 2) when the main circuit power is turned off.
  - No output device is assigned in the initial setting. Assign an output device with [Pr. PD47] as necessary.
  - DI2 and DI3 are assigned to CN1-10 pin and CN1-35 pin respectively in the initial setting. Change them with [Pr. PD44] and [Pr. PD46] when using a manual pulse generator.
  - When using MR-PRU03 parameter unit, use a commercial LAN cable (EIA568 compliant), and keep the wire length to a maximum of 10 m.
  - Programs cannot be edited with the parameter unit.
  - Assign the output devices mentioned to CN1-22 pin, CN1-23 pin, and CN1-25 pin with [Pr. PD23], [Pr. PD24] and [Pr. PD26].
  - The forced stop signal is issued for the servo amplifier. For overall system, apply the emergency stop on the controller side.



Be sure to read through Instruction Manual for the actual wiring and use. Use the equipment after you have a full knowledge of the equipment, safety information and instructions.

MR-J4-03A6-RJ Standard Wiring Diagram Example: Program Method

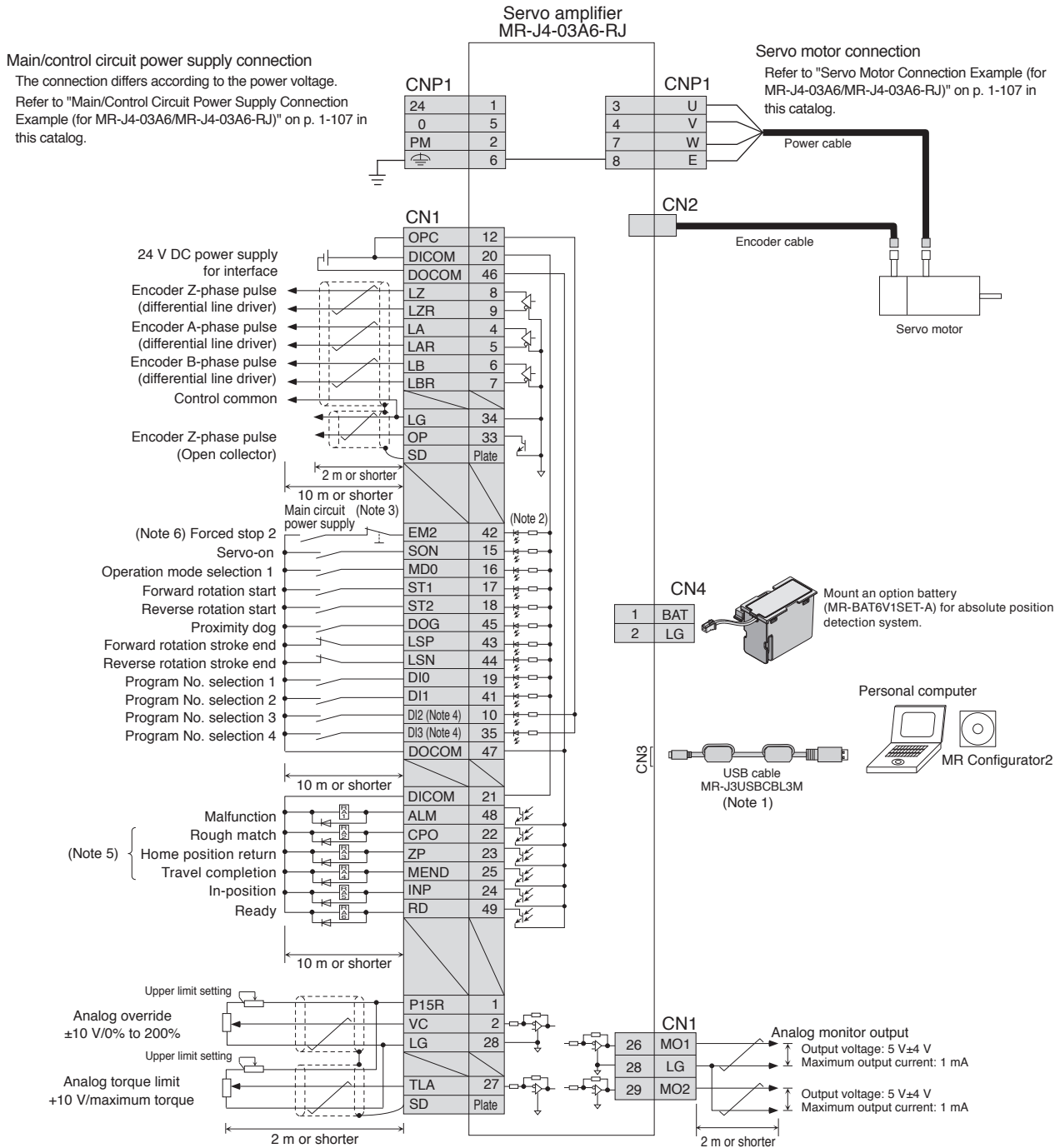

- Notes: 1. USB and RS-422 communication functions are mutually exclusive. Do not use them at the same time.  
 2. This is for sink wiring. Source wiring is also possible. However, when input devices are assigned to CN1-10 pin and CN1-35 pin, be sure to use sink wiring. Source wiring is not possible in this case. In positioning mode, input devices are assigned in the initial setting. Refer to "MR-J4\_A\_RJ MR-J4-03A6-RJ Servo Amplifier Instruction Manual (Positioning Mode)" for details.  
 3. To prevent an unexpected restart of the servo amplifier, create a circuit to turn off EM2 (Forced stop 2) when the main circuit power is turned off.  
 4. DI2 and DI3 are assigned to CN1-10 pin and CN1-35 pin respectively in the initial setting. Change them with [Pr. PD44] and [Pr. PD46] when using a manual pulse generator.  
 5. Assign the output devices mentioned to CN1-22 pin, CN1-23 pin, and CN1-25 pin with [Pr. PD23], [Pr. PD24] and [Pr. PD26].  
 6. The forced stop signal is issued for the servo amplifier. For overall system, apply the emergency stop on the controller side.



Be sure to read through Instruction Manual for the actual wiring and use. Use the equipment after you have a full knowledge of the equipment, safety information and instructions.

## MR-J4-GF(-RJ)/MR-J4-A-RJ Positioning Function: Indexer Method

**GF GF-RJ A-RJ**

Positioning is executed in accordance with the specified stations (maximum of 255 stations).

The servo amplifier automatically calculates the travel distance from the number of stations and gear teeth in the machine and servo motor sides set in the parameters.

Item		Description	
Command method	Command interface	MR-J4-_GF_(-RJ)	CC-Link IE Field Network communication
		MR-J4-_A_-RJ	DI/O (Input: 11 points excluding EM2 (Forced stop 2), output: 8 points) RS-422/RS-485 communication <sup>(Note 1)</sup>
		MR-J4-03A6-RJ	DI/O (Input: 11 points excluding EM2 (Forced stop 2), output: 6 points) RS-422 communication <sup>(Note 2)</sup>
	Operating specification		Positioning in accordance with the specified stations The maximum number of divisions: 255
	Speed command input	MR-J4-_GF_(-RJ)	Select from the point table with the remote register, Set the speed command data (speed and acceleration/deceleration time constants)
		MR-J4-_A_-RJ	Select the rotation speed and acceleration/deceleration time by input signal
		MR-J4-03A6-RJ	
	System		Rotation direction specifying indexer, shortest rotating indexer
	Digital override <sup>(Note 3)</sup>		Select the override multiplying factor by input signal
	Torque limit	MR-J4-_GF_(-RJ)	Set by parameters or link devices
MR-J4-_A_-RJ		Set by parameters or external analog input (0 V DC to +10 V DC/maximum torque)	
MR-J4-03A6-RJ			
Operation mode	Automatic operation mode	Rotation direction specifying indexer	Positions to the specified station. Rotation direction settable
		Shortest rotating indexer	Positions to the specified station. Rotates in the shorter direction from the current position.
	Manual operation mode	JOG operation	Decelerates to a stop regardless of the station
		Station JOG operation	Rotates in a direction specified by the rotation direction decision when the start signal turns on. Positions to the nearest station where the servo motor can decelerate to a stop when the start signal turns off.
	Home position return mode	MR-J4-_GF_(-RJ)	Torque limit changing dog type, torque limit changing data set type, Homing on current position (Method 35, 37)
		MR-J4-_A_-RJ	Torque limit changing dog type, torque limit changing data set type
MR-J4-03A6-RJ			
Other functions	MR-J4-_GF_(-RJ)	Absolute position detection, overtravel prevention with limit switches	
	MR-J4-_A_-RJ	Absolute position detection, backlash compensation, overtravel prevention with external limit switches (LSP/LSN), digital override function	
	MR-J4-03A6-RJ		

Notes: 1. Compatible with RS-422 communication (Mitsubishi Electric general-purpose AC servo protocol) and RS-485 communication (MODBUS® RTU protocol).

2. Compatible with RS-422 communication (Mitsubishi Electric general-purpose AC servo protocol).

3. Supported by MR-J4-\_A\_-RJ and MR-J4-03A6-RJ.

**MR-J4-GF(-RJ)/MR-J4-A-RJ Positioning Function: Indexer Method**

GF GF-RJ A-RJ

Rotation direction specifying indexer

In the rotation direction specifying indexer, the servo motor always rotates in a definite direction. Turn off MD0 (Operation mode selection 1), and turn on MD1 (Operation mode selection 2). The servo motor moves in the station No. decreasing direction with SIG (Rotation direction decision) off, and in the increasing direction with SIG on. When ST1 (Forward rotation start) turns on, the travel amount will be calculated from the current position and the next station position, and then the positioning will be executed to the direction specified by the rotation direction decision. The following timing chart is an example of the operation executed from the station No. 0 where the servo motor is stopped at servo-on.

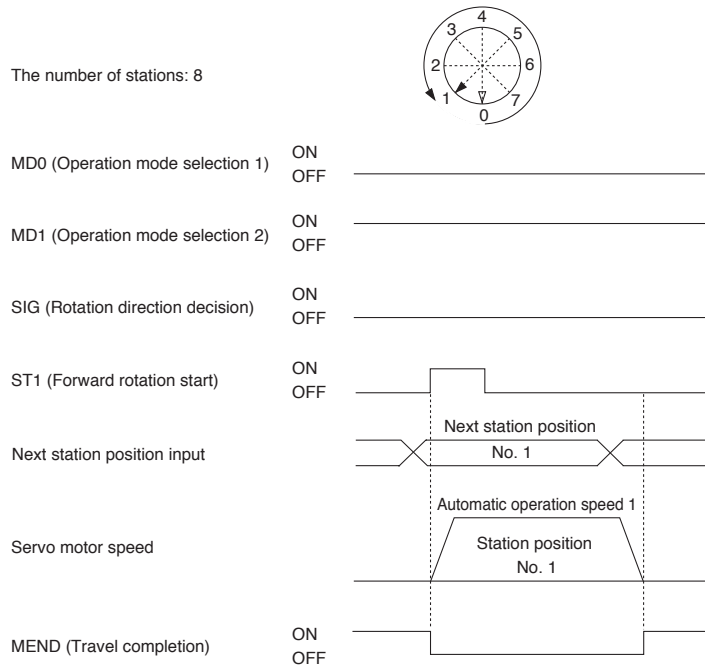

Shortest rotating indexer

In the shortest rotating indexer, the servo motor automatically rotates in the shorter direction. Turn on both MD0 (Operation mode selection 1) and MD1 (Operation mode selection 2). When ST1 (Forward rotation start) turns on, the travel amount will be calculated from the current position and the next station position, and then the positioning will be executed in the shorter direction. The following timing chart is an example of the operation executed from the station No. 0 where the servo motor is stopped at servo-on.

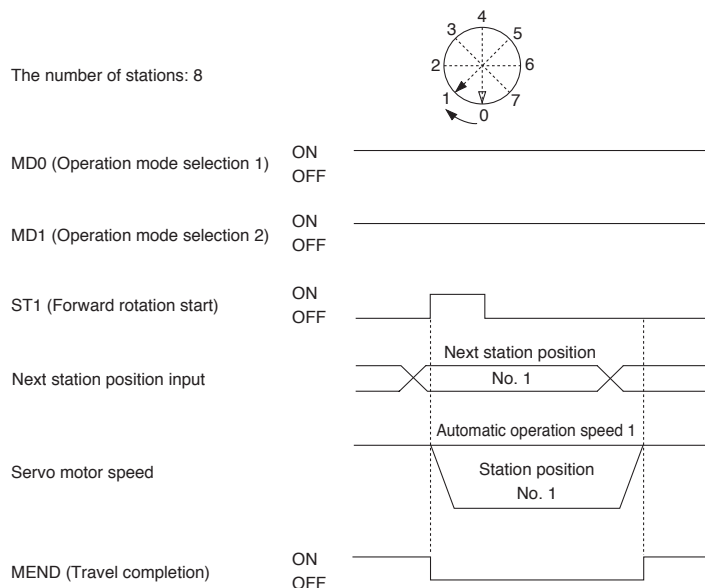

## MR-J4-A-RJ Standard Wiring Diagram Example: Indexer Method

A-RJ

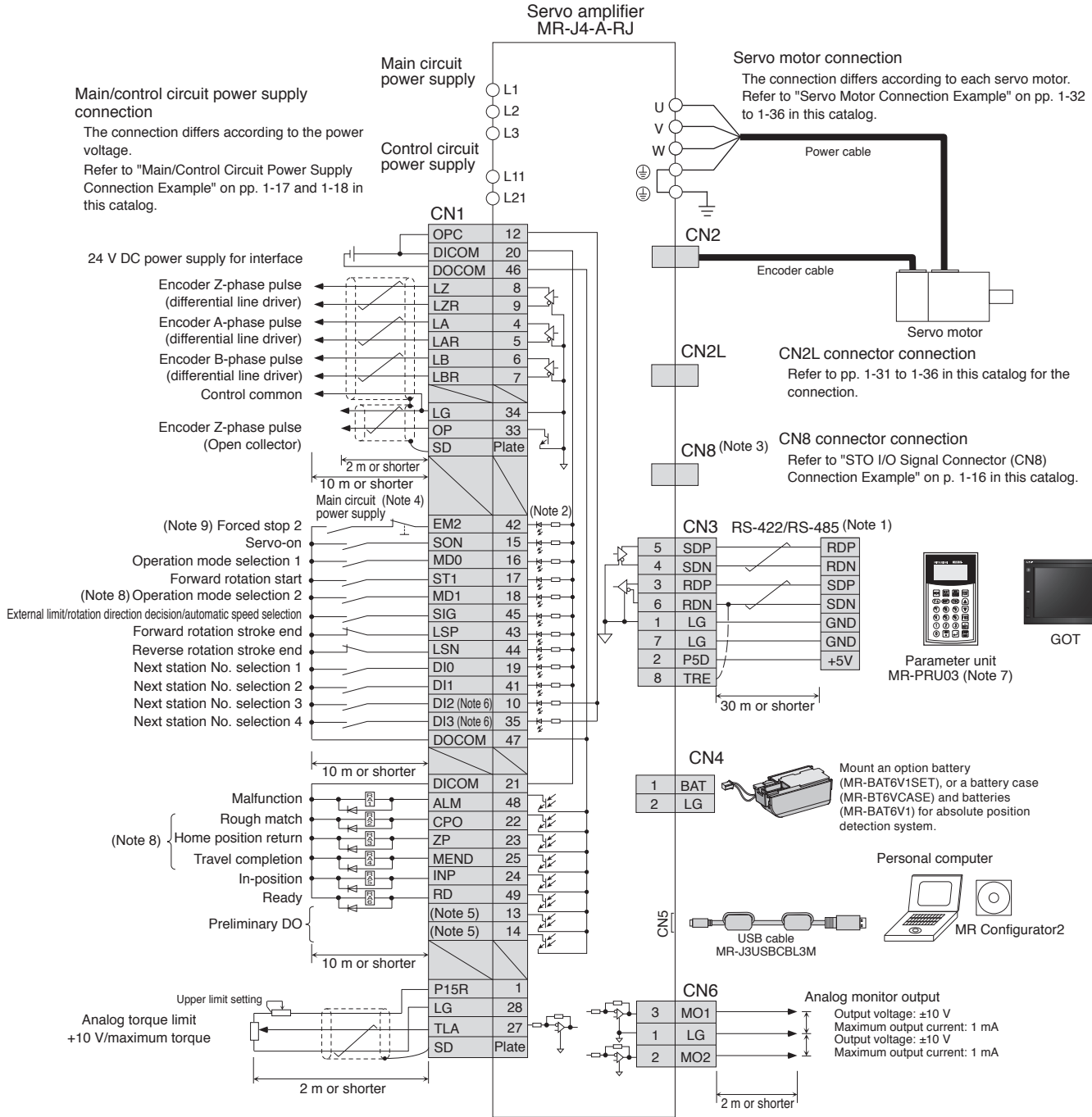

- Notes:
- It is also possible to connect a personal computer to CN3 connector with an RS-422/RS-232C conversion cable. However, USB (CN5 connector) and RS-422/RS-485 (CN3 connector) communication functions are mutually exclusive. Do not use them at the same time. Refer to "Products on the Market for Servo Amplifiers" in this catalog for the RS-422/RS-232C conversion cable.
  - This is for sink wiring. Source wiring is also possible. However, when input devices are assigned to CN1-10 pin and CN1-35 pin, be sure to use sink wiring. Source wiring is not possible in this case. In positioning mode, input devices are assigned in the initial setting. Refer to "MR-J4-A-RJ MR-J4-03A6-RJ Servo Amplifier Instruction Manual (Positioning Mode)" for details.
  - Be sure to attach a short-circuit connector supplied with the servo amplifier when the STO function is not used.
  - To prevent an unexpected restart of the servo amplifier, create a circuit to turn off EM2 (Forced stop 2) when the main circuit power is turned off.
  - No output device is assigned in the initial setting. Assign an output device with [Pr. PD47] as necessary.
  - DI2 and DI3 are assigned to CN1-10 pin and CN1-35 pin respectively in the initial setting. Change them with [Pr. PD44] and [Pr. PD46] when using a manual pulse generator.
  - When using MR-PRU03 parameter unit, use a commercial LAN cable (EIA568 compliant), and keep the wire length to a maximum of 10 m.
  - Assign the output devices mentioned to CN1-18 pin, CN1-22 pin, CN1-23 pin, and CN1-25 pin with [Pr. PD10], [Pr. PD23], [Pr. PD24], and [Pr. PD26].
  - The forced stop signal is issued for the servo amplifier. For overall system, apply the emergency stop on the controller side.



Be sure to read through Instruction Manual for the actual wiring and use. Use the equipment after you have a full knowledge of the equipment, safety information and instructions.



MR-J4-03A6-RJ Standard Wiring Diagram Example: Indexer Method

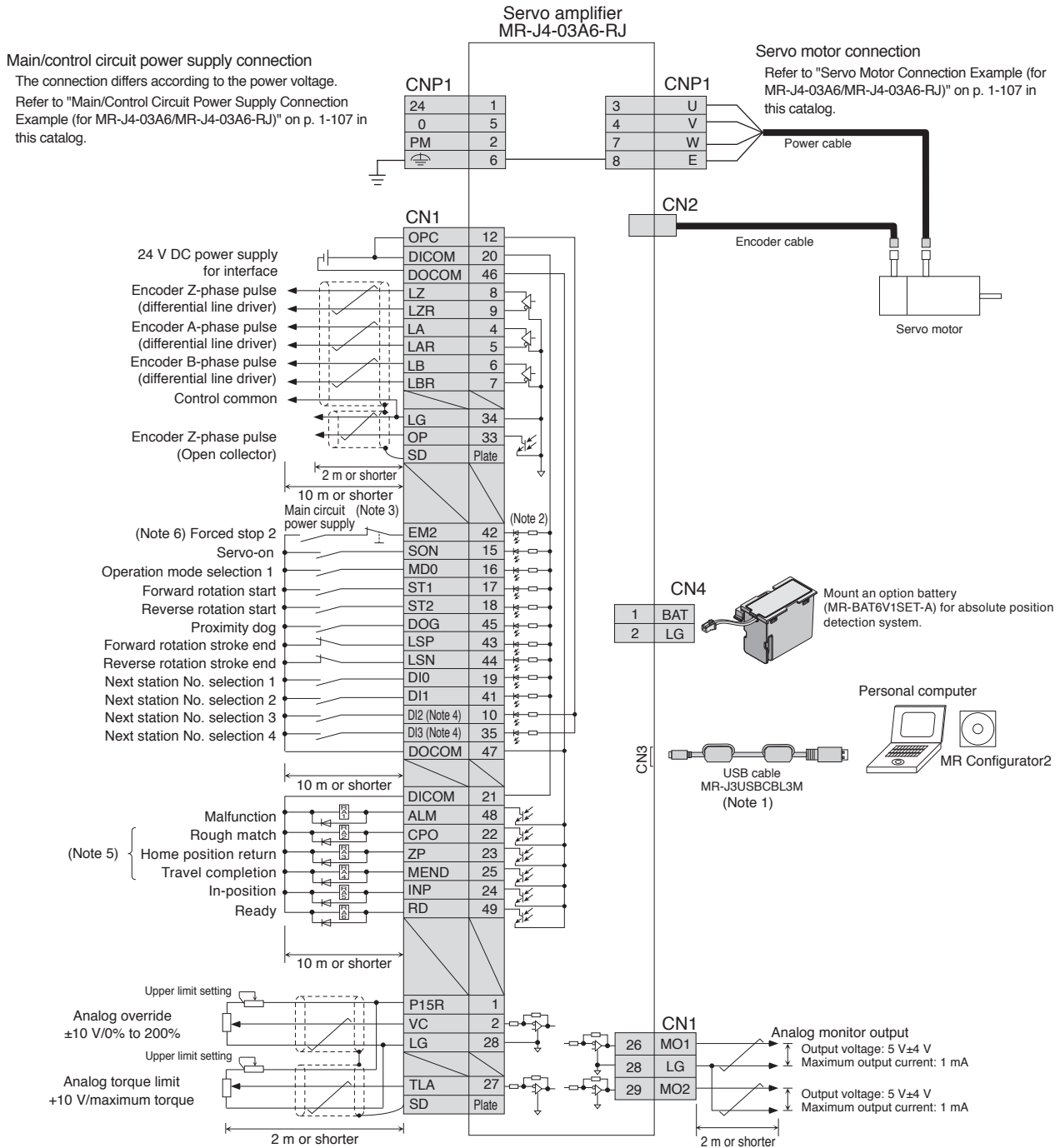

- Notes: 1. USB and RS-422 communication functions are mutually exclusive. Do not use them at the same time.  
 2. This is for sink wiring. Source wiring is also possible. However, when input devices are assigned to CN1-10 pin and CN1-35 pin, be sure to use sink wiring. Source wiring is not possible in this case. In positioning mode, input devices are assigned in the initial setting. Refer to "MR-J4\_A\_RJ MR-J4-03A6-RJ Servo Amplifier Instruction Manual (Positioning Mode)" for details.  
 3. To prevent an unexpected restart of the servo amplifier, create a circuit to turn off EM2 (Forced stop 2) when the main circuit power is turned off.  
 4. DI2 and DI3 are assigned to CN1-10 pin and CN1-35 pin respectively in the initial setting. Change them with [Pr. PD44] and [Pr. PD46] when using a manual pulse generator.  
 5. Assign the output devices mentioned to CN1-18 pin, CN1-22 pin, CN1-23 pin, and CN1-25 pin with [Pr. PD10], [Pr. PD23], [Pr. PD24], and [Pr. PD26].  
 6. The forced stop signal is issued for the servo amplifier. For overall system, apply the emergency stop on the controller side.

**!** Be sure to read through Instruction Manual for the actual wiring and use. Use the equipment after you have a full knowledge of the equipment, safety information and instructions.

Servo Amplifiers

Rotary Servo Motors

Linear Servo Motors

Direct Drive Motors

Options/Peripheral Equipment

LVS/Wires

Product List

Precautions

# Servo Amplifiers

## MODBUS® RTU Specifications (Note 1)

A-RJ

Item	Specifications	
Communication protocol	MODBUS® RTU protocol	
Compliance with standards	EIA-485 (RS-485)	
Numbers connected	1:n (maximum 32) Set stations 1 to 247 by a parameter. (Station 0 is for broadcast communication)	
Communication baud rate [bps]	4800/9600/19200/38400/57600/115200 (set by a parameter)	
Control process	Asynchronous system	
Communication method	Half duplex/full duplex	
Maximum overall extension distance [m]	30	
Communication specifications	Character method	Binary (8-bit fixed)
	Start bit	1-bit
	Stop bit length	Select from the following by a parameter. • Even parity, stop bit length 1-bit (initial value) • Odd parity, stop bit length 1-bit • No parity, stop bit length 2-bit
	Parity check	
	Error check	CRC-16 method
	Terminator	None
Waiting time setting	None	
Client/server classification	Server	

Notes: 1. MR-J4-03A6-RJ is not compatible with MODBUS® RTU.

## MODBUS® RTU Wiring (For Multi-Drop) (Note 6)

A-RJ

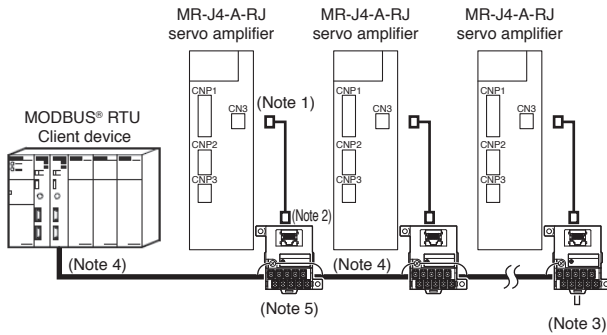

- Notes: 1. Use RJ-45 compatible cable (DSV-CABMD06) designed for MR-J4-A-RJ.  
 2. Use RJ-45 compatible junction connector terminal block (PX7D-10V4-RJ45).  
 3. For the final axis, connect 6-pin and 8-pin of RJ-45 compatible junction connector terminal block (PX7D-10V4-RJ45).  
 4. Use a shielded twisted pair cable between a client device and RJ-45 compatible junction connector terminal block (PX7D-10V4-RJ45), and between each of RJ-45 compatible junction connector terminal blocks (PX7D-10V4-RJ45).  
 5. Connect the shield of the shielded twisted pair cable mentioned in Note 4 to E terminal of RJ-45 compatible junction connector terminal block (PX7D-10V4-RJ45).  
 6. RJ-45 junction connector terminal block (PX7D-10V4-RJ45) and RJ-45 compatible cable (DSV-CABMD06) designed for MR-J4-A-RJ are required even for connecting single axis.

## MODBUS® RTU Compatible Function Codes

A-RJ

MR-J4-\_A\_-RJ servo amplifier and MR-J4-DU\_A\_-RJ drive unit are compatible with following function code.

Code	Function name	Description
03h	Read holding registers	Reading holding registers Reads data stored in holding registers from a client.
08h	Diagnostics	Functional diagnostics When this function code is sent from a client to servers, the servers return the data as it is. This function can be used for checking the communication status.
10h	Preset multiple registers	Writing to multiple registers Writes a series of multiple data to holding registers from a client.

## MODBUS® RTU Functions

A-RJ

The functions of MODBUS® RTU are as follows. MODBUS® RTU can operate and maintain the servo amplifier by remote control.

Function	Description
Status monitor	Reads the items of "Display All" in the monitor function of MR Configurator2 such as servo motor speed and position deviation.
Parameter setting	Reads and writes parameters.
Point table setting	Reads and writes point table data.
Current alarm reading	Reads an alarm No. currently generated.
Alarm history reading	Reads all 16 alarm histories.
Parameter error No. reading/ point table error No. reading	Reads corresponding parameter No. for parameter error and corresponding point table No. for point table error.
Input/output monitor	Reads on/off status of external I/O signals and monitor situation of I/O devices.
Motor driving	Drives servo motors.
Servo amplifier information reading	Reads servo amplifier model, software version, and cumulative power-on time.

Simple Cam Specifications (Note 1)

GF GF-RJ A-RJ

Items			Specifications
Memory capacity	Storage area for cam data		8 Kbytes (non-volatile memory)
	Working area for cam data		8 Kbytes (RAM)
Number of registration			Maximum 8 (depending on cam resolution and the number of coordinates)
Comment			Maximum 32 single-byte characters for each cam data
Cam data	Stroke ratio data type	Cam resolution (Maximum number of registration)	256 (8), 512 (4), 1024 (2), 2048 (1)
		Stroke ratio	-100.000% to 100.000%
	Coordinate data type	Number of coordinates (Maximum number of registration)	2 to 1024 Example: 128 (8), 256 (4), 512 (2), 1024 (1)
		Coordinate data	Input value: 0 to 999999 Output value: -999999 to 999999
Cam curve			12 types (constant speed/constant acceleration/5th curve/single hypotenuse/cycloid/distorted trapezoid/distorted sine/distorted constant speed/trapezoid/reverse trapezoid/double hypotenuse/reverse double hypotenuse)

Notes: 1. Simple cam is not supported by MR-J4-03A6-RJ.

Servo Amplifiers  
Rotary Servo Motors  
Linear Servo Motors  
Direct Drive Motors  
Options/Peripheral Equipment  
LV5/Wires  
Product List  
Precautions

MEMO

# 2

## Rotary Servo Motors

Model Designation.....	2-1
Combinations of Rotary Servo Motor and Servo Amplifier.....	2-4
Combinations of HG-JR Servo Motor Series and Servo Amplifier for Increasing the Maximum Torque to 400% of the Rated Torque ....	2-7
Combinations for Increasing the Maximum Torque .....	2-7
Combinations of Servo Motor with Functional Safety and Servo Amplifier.....	2-8
Specifications	
HG-KR series .....	2-11
HG-MR series.....	2-13
HG-SR series .....	2-15
HG-JR series.....	2-21
HG-RR series .....	2-35
HG-UR series .....	2-37
HG-AK series.....	2-39
Dimensions	
HG-KR series .....	2-42
HG-MR series.....	2-42
HG-SR series .....	2-43
HG-JR series.....	2-44
HG-RR series .....	2-50
HG-UR series .....	2-51
HG-AK series.....	2-52
Geared Servo Motor Specifications	
HG-KR series (G1, G5, and G7).....	2-53
HG-SR series (G1, G1H, G5, and G7) .....	2-60
Sizing Example.....	2-71

\* Refer to p. 5-99 in this catalog for conversion of units.

\* The characteristics and numerical values without tolerances mentioned in this catalog are representative values.

# Rotary Servo Motors

## Model Designation (Note 11)

For 200 V class

**HG - KR 05 3 B**

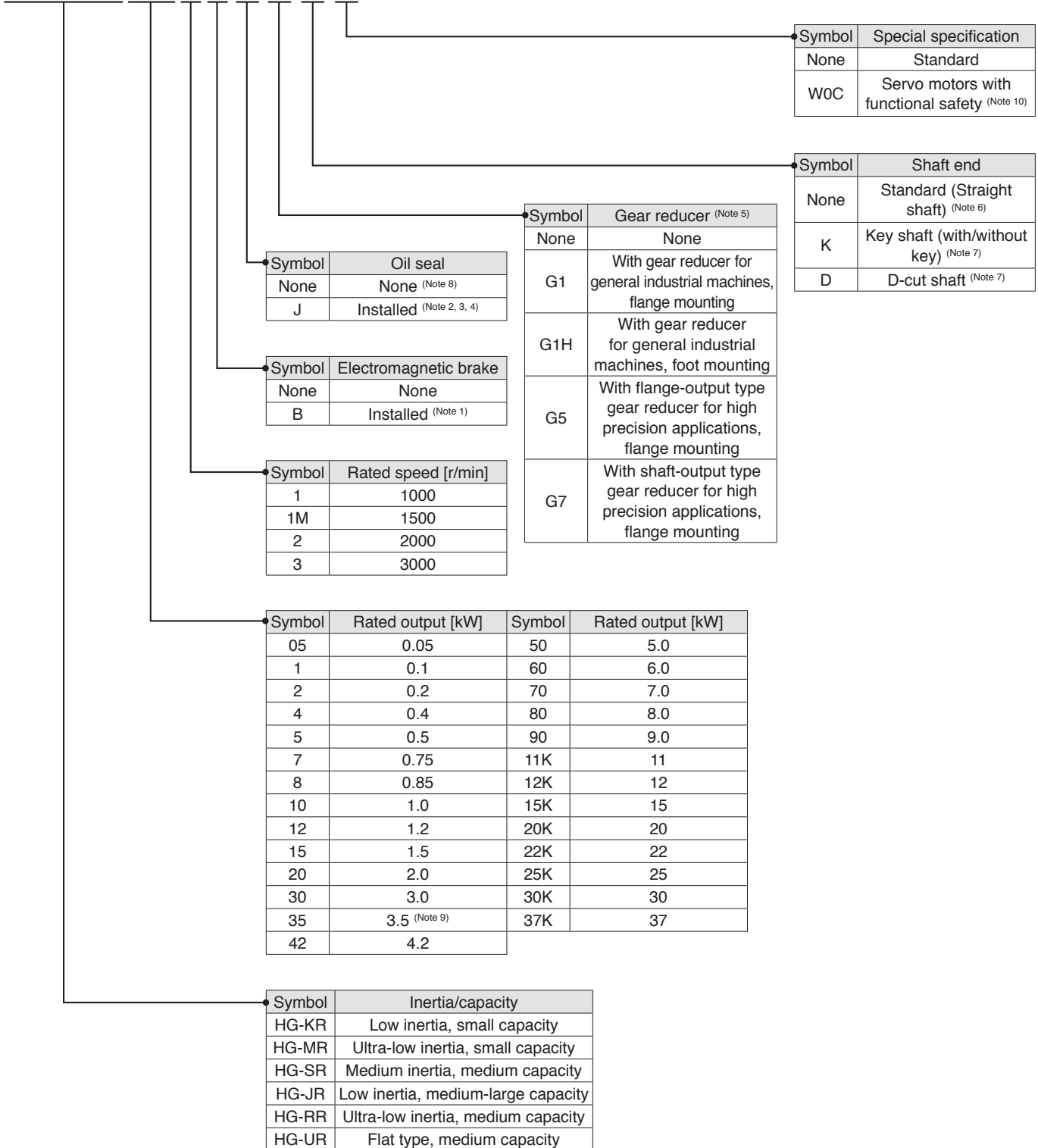

- Notes: 1. Refer to electromagnetic brake specifications of each servo motor series in this catalog for the available models and detailed specifications.  
 2. Available in 0.1 kW or larger HG-KR/HG-MR series and all HG-SR series.  
 3. Oil seal is not installed in the geared servo motor.  
 4. Dimensions for HG-KR/HG-MR series with oil seal are different from those without oil seal. Contact your local sales office for more details. For HG-SR series, dimensions are the same regardless of whether or not oil seal is installed.  
 5. Refer to "Geared Servo Motor Specifications" in this catalog for the available models and detailed specifications.  
 6. Standard HG-SR G1/G1H has a key shaft (with key).  
 7. Refer to special shaft end specifications of each servo motor series in this catalog for the available models and detailed specifications.  
 8. Oil seal is installed in HG-JR, HG-RR, and HG-UR series as a standard.  
 9. For HG-JR353(B), the rated output varies depending on the servo amplifier to be combined. Refer to "HG-JR 3000 r/min Series (Low Inertia, Medium Capacity) (200 V Class) Specifications" in this catalog for details.  
 10. Contact your local sales office for the servo motors with functional safety.  
 11. This section describes what each symbol in a model name indicates. Some combinations of symbols are not available.

## Model Designation (Note 10)

For 400 V class

### HG - SR 5 2 4 B

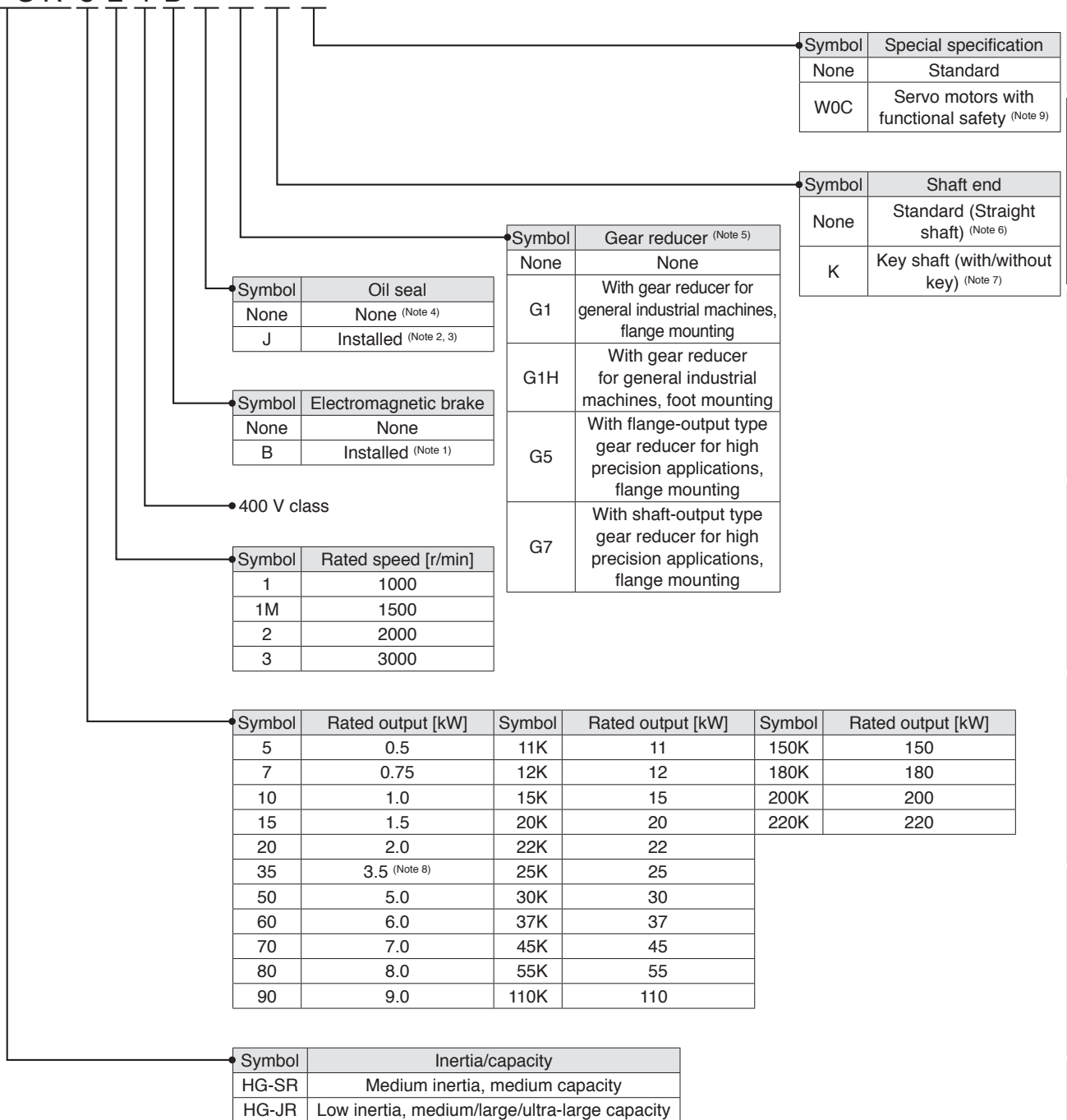

- Notes: 1. Refer to electromagnetic brake specifications of each servo motor series in this catalog for the available models and detailed specifications.  
 2. Available in HG-SR series.  
 3. Oil seal is not installed in the geared servo motor.  
 4. Oil seal is installed in HG-JR series as a standard.  
 5. Refer to "Geared Servo Motor Specifications" in this catalog for the available models and detailed specifications.  
 6. Standard HG-SR G1/G1H has a key shaft (with key).  
 7. Refer to special shaft end specifications of each servo motor series in this catalog for the available models and detailed specifications.  
 8. For HG-JR3534(B), the rated output varies depending on the servo amplifier to be combined. Refer to "HG-JR 3000 r/min Series (Low Inertia, Medium Capacity) (400 V Class) Specifications" in this catalog for details.  
 9. Contact your local sales office for the servo motors with functional safety.  
 10. This section describes what each symbol in a model name indicates. Some combinations of symbols are not available.

Servo Amplifiers  
 Rotary Servo Motors  
 Linear Servo Motors  
 Direct Drive Motors  
 Options/Peripheral Equipment  
 LV5/Wires  
 Product List  
 Precautions

# Rotary Servo Motors

## Model Designation (Note 3)

For 48 V DC/24 V DC

H G - A K 0 1 3 6 B -

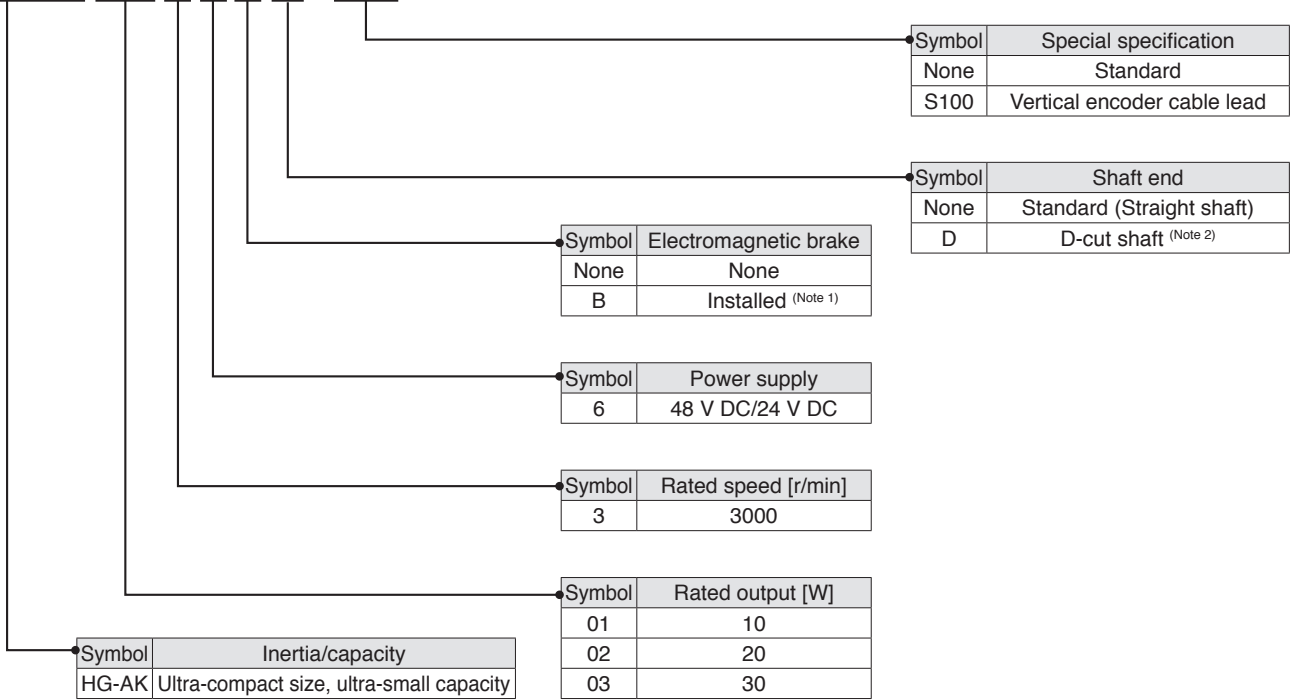

Notes: 1. Refer to "HG-AK Series Electromagnetic Brake Specifications" in this catalog for the available models and detailed specifications.

2. Refer to "HG-AK Series Special Shaft End Specifications" in this catalog for details.

3. This section describes what each symbol in a model name indicates. Some combinations of symbols are not available.



Combinations of Rotary Servo Motor and Servo Amplifier (200 V/100 V Class)

Rotary servo motor		Servo amplifier/Drive unit		
		MR-J4	MR-J4W2 (Note 1)	MR-J4W3 (Note 1)
HG-KR series	HG-KR053(B)	MR-J4-10GF(-RJ), MR-J4-10GF1(-RJ), MR-J4-10B(-RJ), MR-J4-10B1(-RJ), MR-J4-10A(-RJ), MR-J4-10A1(-RJ)	MR-J4W2-22B, MR-J4W2-44B	MR-J4W3-222B, MR-J4W3-444B
	HG-KR13(B)	MR-J4-10GF(-RJ), MR-J4-10GF1(-RJ), MR-J4-10B(-RJ), MR-J4-10B1(-RJ), MR-J4-10A(-RJ), MR-J4-10A1(-RJ)	MR-J4W2-22B, MR-J4W2-44B	MR-J4W3-222B, MR-J4W3-444B
	HG-KR23(B)	MR-J4-20GF(-RJ), MR-J4-20GF1(-RJ), MR-J4-20B(-RJ), MR-J4-20B1(-RJ), MR-J4-20A(-RJ), MR-J4-20A1(-RJ)	MR-J4W2-22B, MR-J4W2-44B	MR-J4W3-222B, MR-J4W3-444B
	HG-KR43(B)	MR-J4-40GF(-RJ), MR-J4-40GF1(-RJ), MR-J4-40B(-RJ), MR-J4-40B1(-RJ), MR-J4-40A(-RJ), MR-J4-40A1(-RJ)	MR-J4W2-44B, MR-J4W2-77B, MR-J4W2-1010B	MR-J4W3-444B
	HG-KR73(B)	MR-J4-70GF(-RJ), MR-J4-70B(-RJ), MR-J4-70A(-RJ)	MR-J4W2-77B, MR-J4W2-1010B	-
HG-MR series	HG-MR053(B)	MR-J4-10GF(-RJ), MR-J4-10GF1(-RJ), MR-J4-10B(-RJ), MR-J4-10B1(-RJ), MR-J4-10A(-RJ), MR-J4-10A1(-RJ)	MR-J4W2-22B, MR-J4W2-44B	MR-J4W3-222B, MR-J4W3-444B
	HG-MR13(B)	MR-J4-10GF(-RJ), MR-J4-10GF1(-RJ), MR-J4-10B(-RJ), MR-J4-10B1(-RJ), MR-J4-10A(-RJ), MR-J4-10A1(-RJ)	MR-J4W2-22B, MR-J4W2-44B	MR-J4W3-222B, MR-J4W3-444B
	HG-MR23(B)	MR-J4-20GF(-RJ), MR-J4-20GF1(-RJ), MR-J4-20B(-RJ), MR-J4-20B1(-RJ), MR-J4-20A(-RJ), MR-J4-20A1(-RJ)	MR-J4W2-22B, MR-J4W2-44B	MR-J4W3-222B, MR-J4W3-444B
	HG-MR43(B)	MR-J4-40GF(-RJ), MR-J4-40GF1(-RJ), MR-J4-40B(-RJ), MR-J4-40B1(-RJ), MR-J4-40A(-RJ), MR-J4-40A1(-RJ)	MR-J4W2-44B, MR-J4W2-77B, MR-J4W2-1010B	MR-J4W3-444B
	HG-MR73(B)	MR-J4-70GF(-RJ), MR-J4-70B(-RJ), MR-J4-70A(-RJ)	MR-J4W2-77B, MR-J4W2-1010B	-
HG-SR 1000 r/min series	HG-SR51(B)	MR-J4-60GF(-RJ), MR-J4-60B(-RJ), MR-J4-60A(-RJ)	MR-J4W2-77B, MR-J4W2-1010B	-
	HG-SR81(B)	MR-J4-100GF(-RJ), MR-J4-100B(-RJ), MR-J4-100A(-RJ)	MR-J4W2-1010B	-
	HG-SR121(B)	MR-J4-200GF(-RJ), MR-J4-200B(-RJ), MR-J4-200A(-RJ)	-	-
	HG-SR201(B)	MR-J4-200GF(-RJ), MR-J4-200B(-RJ), MR-J4-200A(-RJ)	-	-
	HG-SR301(B)	MR-J4-350GF(-RJ), MR-J4-350B(-RJ), MR-J4-350A(-RJ)	-	-
	HG-SR421(B)	MR-J4-500GF(-RJ), MR-J4-500B(-RJ), MR-J4-500A(-RJ)	-	-
HG-SR 2000 r/min series	HG-SR52(B)	MR-J4-60GF(-RJ), MR-J4-60B(-RJ), MR-J4-60A(-RJ)	MR-J4W2-77B, MR-J4W2-1010B	-
	HG-SR102(B)	MR-J4-100GF(-RJ), MR-J4-100B(-RJ), MR-J4-100A(-RJ)	MR-J4W2-1010B	-
	HG-SR152(B)	MR-J4-200GF(-RJ), MR-J4-200B(-RJ), MR-J4-200A(-RJ)	-	-
	HG-SR202(B)	MR-J4-200GF(-RJ), MR-J4-200B(-RJ), MR-J4-200A(-RJ)	-	-
	HG-SR352(B)	MR-J4-350GF(-RJ), MR-J4-350B(-RJ), MR-J4-350A(-RJ)	-	-
	HG-SR502(B)	MR-J4-500GF(-RJ), MR-J4-500B(-RJ), MR-J4-500A(-RJ)	-	-
	HG-SR702(B)	MR-J4-700GF(-RJ), MR-J4-700B(-RJ), MR-J4-DU900B(-RJ), MR-J4-700A(-RJ)	-	-
HG-JR 3000 r/min series	HG-JR53(B)	MR-J4-60GF(-RJ), MR-J4-60B(-RJ), MR-J4-60A(-RJ)	MR-J4W2-77B	-
	HG-JR73(B)	MR-J4-70GF(-RJ), MR-J4-70B(-RJ), MR-J4-70A(-RJ)	MR-J4W2-77B, MR-J4W2-1010B	-
	HG-JR103(B)	MR-J4-100GF(-RJ), MR-J4-100B(-RJ), MR-J4-100A(-RJ)	MR-J4W2-1010B	-

Notes: 1. Any combination of the servo motors is available. Refer to "Combinations of Multi-Axis Servo Amplifier and Servo Motors" on p. 1-8 in this catalog.

Servo Amplifiers

Rotary Servo Motors

Linear Servo Motors

Direct Drive Motors

Options/Peripheral Equipment

LVS/Wires

Product List

Precautions

# Rotary Servo Motors

## Combinations of Rotary Servo Motor and Servo Amplifier (200 V Class)

Rotary servo motor		Servo amplifier/Drive unit		
		MR-J4	MR-J4W2 (Note 1)	MR-J4W3
HG-JR 3000 r/min series	HG-JR153(B)	MR-J4-200GF(-RJ), MR-J4-200B(-RJ), MR-J4-200A(-RJ)	-	-
	HG-JR203(B)	MR-J4-200GF(-RJ), MR-J4-200B(-RJ), MR-J4-200A(-RJ)	-	-
	HG-JR353(B)	MR-J4-350GF(-RJ), MR-J4-350B(-RJ), MR-J4-350A(-RJ)	-	-
	HG-JR503(B)	MR-J4-500GF(-RJ), MR-J4-500B(-RJ), MR-J4-500A(-RJ)	-	-
	HG-JR703(B)	MR-J4-700GF(-RJ), MR-J4-700B(-RJ), MR-J4-DU900B(-RJ), MR-J4-700A(-RJ)	-	-
	HG-JR903(B)	MR-J4-11KGF(-RJ), MR-J4-11KB(-RJ), MR-J4-DU900B(-RJ), MR-J4-11KA(-RJ)	-	-
HG-JR 1000 r/min series	HG-JR601(B)	MR-J4-700GF(-RJ), MR-J4-700B(-RJ), MR-J4-DU900B(-RJ), MR-J4-700A(-RJ)	-	-
	HG-JR801(B)	MR-J4-11KGF(-RJ), MR-J4-11KB(-RJ), MR-J4-DU900B(-RJ), MR-J4-11KA(-RJ)	-	-
	HG-JR12K1(B)	MR-J4-11KGF(-RJ), MR-J4-11KB(-RJ), MR-J4-DU11KB(-RJ), MR-J4-11KA(-RJ)	-	-
	HG-JR15K1	MR-J4-15KGF(-RJ), MR-J4-15KB(-RJ), MR-J4-DU15KB(-RJ), MR-J4-15KA(-RJ)	-	-
	HG-JR20K1	MR-J4-22KGF(-RJ), MR-J4-22KB(-RJ), MR-J4-DU22KB(-RJ), MR-J4-22KA(-RJ)	-	-
	HG-JR25K1	MR-J4-22KGF(-RJ), MR-J4-22KB(-RJ), MR-J4-DU22KB(-RJ), MR-J4-22KA(-RJ)	-	-
	HG-JR30K1	MR-J4-DU30KB(-RJ), MR-J4-DU30KA(-RJ)	-	-
HG-JR37K1	MR-J4-DU37KB(-RJ), MR-J4-DU37KA(-RJ)	-	-	
HG-JR 1500 r/min series	HG-JR701M(B)	MR-J4-700GF(-RJ), MR-J4-700B(-RJ), MR-J4-DU900B(-RJ), MR-J4-700A(-RJ)	-	-
	HG-JR11K1M(B)	MR-J4-11KGF(-RJ), MR-J4-11KB(-RJ), MR-J4-DU11KB(-RJ), MR-J4-11KA(-RJ)	-	-
	HG-JR15K1M(B)	MR-J4-15KGF(-RJ), MR-J4-15KB(-RJ), MR-J4-DU15KB(-RJ), MR-J4-15KA(-RJ)	-	-
	HG-JR22K1M	MR-J4-22KGF(-RJ), MR-J4-22KB(-RJ), MR-J4-DU22KB(-RJ), MR-J4-22KA(-RJ)	-	-
	HG-JR30K1M	MR-J4-DU30KB(-RJ), MR-J4-DU30KA(-RJ)	-	-
	HG-JR37K1M	MR-J4-DU37KB(-RJ), MR-J4-DU37KA(-RJ)	-	-
HG-RR series	HG-RR103(B)	MR-J4-200GF(-RJ), MR-J4-200B(-RJ), MR-J4-200A(-RJ)	-	-
	HG-RR153(B)	MR-J4-200GF(-RJ), MR-J4-200B(-RJ), MR-J4-200A(-RJ)	-	-
	HG-RR203(B)	MR-J4-350GF(-RJ), MR-J4-350B(-RJ), MR-J4-350A(-RJ)	-	-
	HG-RR353(B)	MR-J4-500GF(-RJ), MR-J4-500B(-RJ), MR-J4-500A(-RJ)	-	-
	HG-RR503(B)	MR-J4-500GF(-RJ), MR-J4-500B(-RJ), MR-J4-500A(-RJ)	-	-
HG-UR series	HG-UR72(B)	MR-J4-70GF(-RJ), MR-J4-70B(-RJ), MR-J4-70A(-RJ)	MR-J4W2-77B MR-J4W2-1010B	-
	HG-UR152(B)	MR-J4-200GF(-RJ), MR-J4-200B(-RJ), MR-J4-200A(-RJ)	-	-
	HG-UR202(B)	MR-J4-350GF(-RJ), MR-J4-350B(-RJ), MR-J4-350A(-RJ)	-	-
	HG-UR352(B)	MR-J4-500GF(-RJ), MR-J4-500B(-RJ), MR-J4-500A(-RJ)	-	-
	HG-UR502(B)	MR-J4-500GF(-RJ), MR-J4-500B(-RJ), MR-J4-500A(-RJ)	-	-

Notes: 1. Any combination of the servo motors is available. Refer to "Combinations of Multi-Axis Servo Amplifier and Servo Motors" on p. 1-8 in this catalog.

Combinations of Rotary Servo Motor and Servo Amplifier (400 V Class)

Rotary servo motor		Servo amplifier/Drive unit		
		MR-J4	MR-J4W2	MR-J4W3
HG-SR 2000 r/min series	HG-SR524(B)	MR-J4-60GF4(-RJ), MR-J4-60B4(-RJ), MR-J4-60A4(-RJ)	-	-
	HG-SR1024(B)	MR-J4-100GF4(-RJ), MR-J4-100B4(-RJ), MR-J4-100A4(-RJ)	-	-
	HG-SR1524(B)	MR-J4-200GF4(-RJ), MR-J4-200B4(-RJ), MR-J4-200A4(-RJ)	-	-
	HG-SR2024(B)	MR-J4-200GF4(-RJ), MR-J4-200B4(-RJ), MR-J4-200A4(-RJ)	-	-
	HG-SR3524(B)	MR-J4-350GF4(-RJ), MR-J4-350B4(-RJ), MR-J4-350A4(-RJ)	-	-
	HG-SR5024(B)	MR-J4-500GF4(-RJ), MR-J4-500B4(-RJ), MR-J4-500A4(-RJ)	-	-
	HG-SR7024(B)	MR-J4-700GF4(-RJ), MR-J4-700B4(-RJ), MR-J4-DU900B4(-RJ), MR-J4-700A4(-RJ)	-	-
HG-JR 3000 r/min series	HG-JR534(B)	MR-J4-60GF4(-RJ), MR-J4-60B4(-RJ), MR-J4-60A4(-RJ)	-	-
	HG-JR734(B)	MR-J4-100GF4(-RJ), MR-J4-100B4(-RJ), MR-J4-100A4(-RJ)	-	-
	HG-JR1034(B)	MR-J4-100GF4(-RJ), MR-J4-100B4(-RJ), MR-J4-100A4(-RJ)	-	-
	HG-JR1534(B)	MR-J4-200GF4(-RJ), MR-J4-200B4(-RJ), MR-J4-200A4(-RJ)	-	-
	HG-JR2034(B)	MR-J4-200GF4(-RJ), MR-J4-200B4(-RJ), MR-J4-200A4(-RJ)	-	-
	HG-JR3534(B)	MR-J4-350GF4(-RJ), MR-J4-350B4(-RJ), MR-J4-350A4(-RJ)	-	-
	HG-JR5034(B)	MR-J4-500GF4(-RJ), MR-J4-500B4(-RJ), MR-J4-500A4(-RJ)	-	-
	HG-JR7034(B)	MR-J4-700GF4(-RJ), MR-J4-700B4(-RJ), MR-J4-DU900B4(-RJ), MR-J4-700A4(-RJ)	-	-
	HG-JR9034(B)	MR-J4-11KGF4(-RJ), MR-J4-11KB4(-RJ), MR-J4-DU900B4(-RJ), MR-J4-11KA4(-RJ)	-	-
HG-JR 1000 r/min series	HG-JR6014(B)	MR-J4-700GF4(-RJ), MR-J4-700B4(-RJ), MR-J4-DU900B4(-RJ), MR-J4-700A4(-RJ)	-	-
	HG-JR8014(B)	MR-J4-11KGF4(-RJ), MR-J4-11KB4(-RJ), MR-J4-DU900B4(-RJ), MR-J4-11KA4(-RJ)	-	-
	HG-JR12K14(B)	MR-J4-11KGF4(-RJ), MR-J4-11KB4(-RJ), MR-J4-DU11KB4(-RJ), MR-J4-11KA4(-RJ)	-	-
	HG-JR15K14	MR-J4-15KGF4(-RJ), MR-J4-15KB4(-RJ), MR-J4-DU15KB4(-RJ), MR-J4-15KA4(-RJ)	-	-
	HG-JR20K14	MR-J4-22KGF4(-RJ), MR-J4-22KB4(-RJ), MR-J4-DU22KB4(-RJ), MR-J4-22KA4(-RJ)	-	-
	HG-JR25K14	MR-J4-22KGF4(-RJ), MR-J4-22KB4(-RJ), MR-J4-DU22KB4(-RJ), MR-J4-22KA4(-RJ)	-	-
	HG-JR30K14	MR-J4-DU30KB4(-RJ), MR-J4-DU30KA4(-RJ)	-	-
	HG-JR37K14	MR-J4-DU37KB4(-RJ), MR-J4-DU37KA4(-RJ)	-	-
HG-JR 1500 r/min series	HG-JR701M4(B)	MR-J4-700GF4(-RJ), MR-J4-700B4(-RJ), MR-J4-DU900B4(-RJ), MR-J4-700A4(-RJ)	-	-
	HG-JR11K1M4(B)	MR-J4-11KGF4(-RJ), MR-J4-11KB4(-RJ), MR-J4-DU11KB4(-RJ), MR-J4-11KA4(-RJ)	-	-
	HG-JR15K1M4(B)	MR-J4-15KGF4(-RJ), MR-J4-15KB4(-RJ), MR-J4-DU15KB4(-RJ), MR-J4-15KA4(-RJ)	-	-
	HG-JR22K1M4	MR-J4-22KGF4(-RJ), MR-J4-22KB4(-RJ), MR-J4-DU22KB4(-RJ), MR-J4-22KA4(-RJ)	-	-
	HG-JR30K1M4	MR-J4-DU30KB4(-RJ), MR-J4-DU30KA4(-RJ)	-	-
	HG-JR37K1M4	MR-J4-DU37KB4(-RJ), MR-J4-DU37KA4(-RJ)	-	-
	HG-JR45K1M4	MR-J4-DU45KB4(-RJ), MR-J4-DU45KA4(-RJ)	-	-
	HG-JR55K1M4	MR-J4-DU55KB4(-RJ), MR-J4-DU55KA4(-RJ)	-	-

Servo Amplifiers

Rotary Servo Motors

Linear Servo Motors

Direct Drive Motors

Options/Peripheral  
Equipment

LVS/Wires

Product List

Precautions

## Rotary Servo Motors

### Combinations of Rotary Servo Motor and Servo Amplifier (48 V DC/24 V DC Class)

Rotary servo motor		Servo amplifier		
		MR-J4	MR-J4W2 (Note 1)	MR-J4W3
HG-AK series	HG-AK0136(B)	MR-J4-03A6(-RJ)	MR-J4W2-0303B6	-
	HG-AK0236(B)	MR-J4-03A6(-RJ)	MR-J4W2-0303B6	-
	HG-AK0336(B)	MR-J4-03A6(-RJ)	MR-J4W2-0303B6	-

Notes: 1. Any combination of the servo motors is available. Refer to "Combinations of Multi-Axis Servo Amplifier and Servo Motors" on p. 1-8 in this catalog.

### Combinations of HG-JR Servo Motor Series and Servo Amplifier (200 V/400 V Class) for Increasing the Maximum Torque to 400% of the Rated Torque

The following combination of the HG-JR servo motor and the servo amplifier increases the maximum torque from 300% to 400% of the rated torque.

Rotary servo motor		Servo amplifier/Drive unit		
		MR-J4	MR-J4W2 (Note 1)	MR-J4W3
HG-JR 3000 r/min series (200 V class)	HG-JR53(B) (Note 2)	MR-J4-100GF(-RJ), MR-J4-100B(-RJ), MR-J4-100A(-RJ)	MR-J4W2-1010B	-
	HG-JR73(B) (Note 2)	MR-J4-200GF(-RJ), MR-J4-200B(-RJ), MR-J4-200A(-RJ)	-	-
	HG-JR103(B) (Note 2)	MR-J4-200GF(-RJ), MR-J4-200B(-RJ), MR-J4-200A(-RJ)	-	-
	HG-JR153(B)	MR-J4-350GF(-RJ), MR-J4-350B(-RJ), MR-J4-350A(-RJ)	-	-
	HG-JR203(B)	MR-J4-350GF(-RJ), MR-J4-350B(-RJ), MR-J4-350A(-RJ)	-	-
	HG-JR353(B)	MR-J4-500GF(-RJ), MR-J4-500B(-RJ), MR-J4-500A(-RJ)	-	-
	HG-JR503(B)	MR-J4-700GF(-RJ), MR-J4-700B(-RJ), MR-J4-DU900B(-RJ), MR-J4-700A(-RJ)	-	-
HG-JR 3000 r/min series (400 V class)	HG-JR534(B)	MR-J4-100GF4(-RJ), MR-J4-100B4(-RJ), MR-J4-100A4(-RJ)	-	-
	HG-JR734(B)	MR-J4-200GF4(-RJ), MR-J4-200B4(-RJ), MR-J4-200A4(-RJ)	-	-
	HG-JR1034(B)	MR-J4-200GF4(-RJ), MR-J4-200B4(-RJ), MR-J4-200A4(-RJ)	-	-
	HG-JR1534(B)	MR-J4-350GF4(-RJ), MR-J4-350B4(-RJ), MR-J4-350A4(-RJ)	-	-
	HG-JR2034(B)	MR-J4-350GF4(-RJ), MR-J4-350B4(-RJ), MR-J4-350A4(-RJ)	-	-
	HG-JR3534(B)	MR-J4-500GF4(-RJ), MR-J4-500B4(-RJ), MR-J4-500A4(-RJ)	-	-
	HG-JR5034(B)	MR-J4-700GF4(-RJ), MR-J4-700B4(-RJ), MR-J4-DU900B4(-RJ), MR-J4-700A4(-RJ)	-	-

Notes: 1. Any combination of the servo motors is available. Refer to "Combinations of Multi-Axis Servo Amplifier and Servo Motors" on p. 1-8 in this catalog.

2. When a 1-phase 200 V AC input is used, increasing the maximum torque to 400% is not possible with HG-JR servo motor series.

### Combinations for Increasing the Maximum Torque (200 V/400 V Class)

With the following combinations of the servo motors and the drive units, the maximum torque of the servo motors can be increased when the "Selection of maximally increasing torque function with drive unit" is enabled with a parameter.

Rotary servo motor		Drive unit
HG-SR series	HG-SR702(B)	MR-J4-DU900B(-RJ)
	HG-SR7024(B)	MR-J4-DU900B4(-RJ)
HG-JR series	HG-JR703(B)	MR-J4-DU900B(-RJ)
	HG-JR701M(B)	MR-J4-DU900B(-RJ)
	HG-JR7034(B)	MR-J4-DU900B4(-RJ)
	HG-JR701M4(B)	MR-J4-DU900B4(-RJ)

**Combinations of Servo Motor with Functional Safety and Servo Amplifier (200 V Class)**

The safety sub-function can be expanded with the combination of the servo motor with functional safety, MR-J4-GF-RJ/MR-J4-B-RJ/MR-J4-A-RJ servo amplifier, and MR-D30 functional safety unit. The servo motors with functional safety are available in HG-KR/HG-SR/HG-JR series.

The specifications and dimensions of the servo motors with functional safety are the same as the standard. Combine MR-D30 with the following servo amplifiers to expand the safety sub-function by using the servo motors with functional safety.

Servo motors with functional safety	Servo amplifier/Drive unit		
	MR-J4	MR-J4W2	MR-J4W3
HG-KR053(B)W0C	MR-J4-10GF-RJ, MR-J4-10GF1-RJ, MR-J4-10B-RJ, MR-J4-10B1-RJ, MR-J4-10A-RJ, MR-J4-10A1-RJ	-	-
HG-KR13(B)W0C	MR-J4-10GF-RJ, MR-J4-10GF1-RJ, MR-J4-10B-RJ, MR-J4-10B1-RJ, MR-J4-10A-RJ, MR-J4-10A1-RJ	-	-
HG-KR23(B)W0C	MR-J4-20GF-RJ, MR-J4-20GF1-RJ, MR-J4-20B-RJ, MR-J4-20B1-RJ, MR-J4-20A-RJ, MR-J4-20A1-RJ	-	-
HG-KR43(B)W0C	MR-J4-40GF-RJ, MR-J4-40GF1-RJ, MR-J4-40B-RJ, MR-J4-40B1-RJ, MR-J4-40A-RJ, MR-J4-40A1-RJ	-	-
HG-KR73(B)W0C	MR-J4-70GF-RJ, MR-J4-70B-RJ, MR-J4-70A-RJ	-	-
HG-SR51(B)W0C	MR-J4-60GF-RJ, MR-J4-60B-RJ, MR-J4-60A-RJ	-	-
HG-SR81(B)W0C	MR-J4-100GF-RJ, MR-J4-100B-RJ, MR-J4-100A-RJ	-	-
HG-SR121(B)W0C	MR-J4-200GF-RJ, MR-J4-200B-RJ, MR-J4-200A-RJ	-	-
HG-SR201(B)W0C	MR-J4-200GF-RJ, MR-J4-200B-RJ, MR-J4-200A-RJ	-	-
HG-SR301(B)W0C	MR-J4-350GF-RJ, MR-J4-350B-RJ, MR-J4-350A-RJ	-	-
HG-SR421(B)W0C	MR-J4-500GF-RJ, MR-J4-500B-RJ, MR-J4-500A-RJ	-	-
HG-SR52(B)W0C	MR-J4-60GF-RJ, MR-J4-60B-RJ, MR-J4-60A-RJ	-	-
HG-SR102(B)W0C	MR-J4-100GF-RJ, MR-J4-100B-RJ, MR-J4-100A-RJ	-	-
HG-SR152(B)W0C	MR-J4-200GF-RJ, MR-J4-200B-RJ, MR-J4-200A-RJ	-	-
HG-SR202(B)W0C	MR-J4-200GF-RJ, MR-J4-200B-RJ, MR-J4-200A-RJ	-	-
HG-SR352(B)W0C	MR-J4-350GF-RJ, MR-J4-350B-RJ, MR-J4-350A-RJ	-	-
HG-SR502(B)W0C	MR-J4-500GF-RJ, MR-J4-500B-RJ, MR-J4-500A-RJ	-	-
HG-SR702(B)W0C	MR-J4-700GF-RJ, MR-J4-700B-RJ, MR-J4-DU900B-RJ (Note 3), MR-J4-700A-RJ	-	-
HG-JR53(B)W0C	MR-J4-60GF-RJ, MR-J4-100GF-RJ (Note 1, 2), MR-J4-60B-RJ, MR-J4-100B-RJ (Note 1, 2), MR-J4-60A-RJ, MR-J4-100A-RJ (Note 1, 2)	-	-
HG-JR73(B)W0C	MR-J4-70GF-RJ, MR-J4-200GF-RJ (Note 1, 2), MR-J4-70B-RJ, MR-J4-200B-RJ (Note 1, 2), MR-J4-70A-RJ, MR-J4-200A-RJ (Note 1, 2)	-	-
HG-JR103(B)W0C	MR-J4-100GF-RJ, MR-J4-200GF-RJ (Note 1, 2), MR-J4-100B-RJ, MR-J4-200B-RJ (Note 1, 2), MR-J4-100A-RJ, MR-J4-200A-RJ (Note 1, 2)	-	-
HG-JR153(B)W0C	MR-J4-200GF-RJ, MR-J4-350GF-RJ (Note 1), MR-J4-200B-RJ, MR-J4-350B-RJ (Note 1), MR-J4-200A-RJ, MR-J4-350A-RJ (Note 1)	-	-
HG-JR203(B)W0C	MR-J4-200GF-RJ, MR-J4-350GF-RJ (Note 1), MR-J4-200B-RJ, MR-J4-350B-RJ (Note 1), MR-J4-200A-RJ, MR-J4-350A-RJ (Note 1)	-	-
HG-JR353(B)W0C	MR-J4-350GF-RJ, MR-J4-500GF-RJ (Note 1), MR-J4-350B-RJ, MR-J4-500B-RJ (Note 1), MR-J4-350A-RJ, MR-J4-500A-RJ (Note 1)	-	-
HG-JR503(B)W0C	MR-J4-500GF-RJ, MR-J4-700GF-RJ (Note 1), MR-J4-500B-RJ, MR-J4-700B-RJ (Note 1), MR-J4-DU900B-RJ (Note 1), MR-J4-500A-RJ, MR-J4-700A-RJ (Note 1)	-	-
HG-JR703(B)W0C	MR-J4-700GF-RJ, MR-J4-700B-RJ, MR-J4-DU900B-RJ (Note 3), MR-J4-700A-RJ	-	-
HG-JR903(B)W0C	MR-J4-11KGF-RJ, MR-J4-11KB-RJ, MR-J4-DU900B(-RJ), MR-J4-11KA-RJ	-	-
HG-JR701M(B)W0C	MR-J4-700GF-RJ, MR-J4-700B-RJ, MR-J4-DU900B-RJ (Note 3), MR-J4-700A-RJ	-	-
HG-JR11K1M(B)W0C	MR-J4-11KGF-RJ, MR-J4-11KB-RJ, MR-J4-DU11KB-RJ, MR-J4-11KA-RJ	-	-
HG-JR15K1M(B)W0C	MR-J4-15KGF-RJ, MR-J4-15KB-RJ, MR-J4-DU15KB-RJ, MR-J4-15KA-RJ	-	-
HG-JR22K1MW0C	MR-J4-22KGF-RJ, MR-J4-22KB-RJ, MR-J4-DU22KB-RJ, MR-J4-22KA-RJ	-	-

Notes: 1. This combination increases the maximum torque from 300% to 400% of the rated torque.  
 2. When a 1-phase 200 V AC input is used, increasing the maximum torque to 400% is not possible with HG-JR servo motor series.  
 3. The maximum torque can be increased when the "Selection of maximally increasing torque function with drive unit" is enabled with a parameter.

Servo Amplifiers  
 Rotary Servo Motors  
 Linear Servo Motors  
 Direct Drive Motors  
 Options/Peripheral Equipment  
 LV5/Wires  
 Product List  
 Precautions

# Rotary Servo Motors

## Combinations of Servo Motor with Functional Safety and Servo Amplifier (400 V Class)

Servo motors with functional safety	Servo amplifier/Drive unit		
	MR-J4	MR-J4W2	MR-J4W3
HG-SR524(B)W0C	MR-J4-60GF4-RJ, MR-J4-60B4-RJ, MR-J4-60A4-RJ	-	-
HG-SR1024(B)W0C	MR-J4-100GF4-RJ, MR-J4-100B4-RJ, MR-J4-100A4-RJ	-	-
HG-SR1524(B)W0C	MR-J4-200GF4-RJ, MR-J4-200B4-RJ, MR-J4-200A4-RJ	-	-
HG-SR2024(B)W0C	MR-J4-200GF4-RJ, MR-J4-200B4-RJ, MR-J4-200A4-RJ	-	-
HG-SR3524(B)W0C	MR-J4-350GF4-RJ, MR-J4-350B4-RJ, MR-J4-350A4-RJ	-	-
HG-SR5024(B)W0C	MR-J4-500GF4-RJ, MR-J4-500B4-RJ, MR-J4-500A4-RJ	-	-
HG-SR7024(B)W0C	MR-J4-700GF4-RJ, MR-J4-700B4-RJ, MR-J4-DU900B4-RJ <sup>(Note 2)</sup> , MR-J4-700A4-RJ	-	-
HG-JR534(B)W0C	MR-J4-60GF4-RJ, MR-J4-100GF4-RJ <sup>(Note 1)</sup> , MR-J4-60B4-RJ, MR-J4-100B4-RJ <sup>(Note 1)</sup> , MR-J4-60A4-RJ, MR-J4-100A4-RJ <sup>(Note 1)</sup>	-	-
HG-JR734(B)W0C	MR-J4-100GF4-RJ, MR-J4-200GF4-RJ <sup>(Note 1)</sup> , MR-J4-100B4-RJ, MR-J4-200B4-RJ <sup>(Note 1)</sup> , MR-J4-100A4-RJ, MR-J4-200A4-RJ <sup>(Note 1)</sup>	-	-
HG-JR1034(B)W0C	MR-J4-100GF4-RJ, MR-J4-200GF4-RJ <sup>(Note 1)</sup> , MR-J4-100B4-RJ, MR-J4-200B4-RJ <sup>(Note 1)</sup> , MR-J4-100A4-RJ, MR-J4-200A4-RJ <sup>(Note 1)</sup>	-	-
HG-JR1534(B)W0C	MR-J4-200GF4-RJ, MR-J4-350GF4-RJ <sup>(Note 1)</sup> , MR-J4-200B4-RJ, MR-J4-350B4-RJ <sup>(Note 1)</sup> , MR-J4-200A4-RJ, MR-J4-350A4-RJ <sup>(Note 1)</sup>	-	-
HG-JR2034(B)W0C	MR-J4-200GF4-RJ, MR-J4-350GF4-RJ <sup>(Note 1)</sup> , MR-J4-200B4-RJ, MR-J4-350B4-RJ <sup>(Note 1)</sup> , MR-J4-200A4-RJ, MR-J4-350A4-RJ <sup>(Note 1)</sup>	-	-
HG-JR3534(B)W0C	MR-J4-350GF4-RJ, MR-J4-500GF4-RJ <sup>(Note 1)</sup> , MR-J4-350B4-RJ, MR-J4-500B4-RJ <sup>(Note 1)</sup> , MR-J4-350A4-RJ, MR-J4-500A4-RJ <sup>(Note 1)</sup>	-	-
HG-JR5034(B)W0C	MR-J4-500GF4-RJ, MR-J4-700GF4-RJ <sup>(Note 1)</sup> , MR-J4-500B4-RJ, MR-J4-700B4-RJ <sup>(Note 1)</sup> , MR-J4-DU900B4-RJ <sup>(Note 1)</sup> , MR-J4-500A4-RJ, MR-J4-700A4-RJ <sup>(Note 1)</sup>	-	-
HG-JR7034(B)W0C	MR-J4-700GF4-RJ, MR-J4-700B4-RJ, MR-J4-DU900B4-RJ <sup>(Note 2)</sup> , MR-J4-700A4-RJ	-	-
HG-JR9034(B)W0C	MR-J4-11KGF4-RJ, MR-J4-11KB4-RJ, MR-J4-DU900B4-RJ, MR-J4-11KA4-RJ	-	-
HG-JR701M4(B)W0C	MR-J4-700GF4-RJ, MR-J4-700B4-RJ, MR-J4-DU900B4-RJ <sup>(Note 2)</sup> , MR-J4-700A4-RJ	-	-
HG-JR11K1M4(B)W0C	MR-J4-11KGF4-RJ, MR-J4-11KB4-RJ, MR-J4-DU11KB4-RJ, MR-J4-11KA4-RJ	-	-
HG-JR15K1M4(B)W0C	MR-J4-15KGF4-RJ, MR-J4-15KB4-RJ, MR-J4-DU15KB4-RJ, MR-J4-15KA4-RJ	-	-
HG-JR22K1M4W0C	MR-J4-22KGF4-RJ, MR-J4-22KB4-RJ, MR-J4-DU22KB4-RJ, MR-J4-22KA4-RJ	-	-

Servo motors with functional safety	Servo amplifier	
	Drive unit	Power regeneration converter unit
HG-JR110K24W0C <sup>(Note 3)</sup>	MR-J4-DU55KB4-RJ100 x 2	MR-CV55K4 x 2
HG-JR150K24W0C <sup>(Note 3)</sup>	MR-J4-DU45KB4-RJ100 x 4	MR-CV55K4 x 4
HG-JR180K24W0C <sup>(Note 3)</sup>	MR-J4-DU45KB4-RJ100 x 4	MR-CV55K4 x 4
HG-JR200K24W0C <sup>(Note 3)</sup>	MR-J4-DU55KB4-RJ100 x 4	MR-CV55K4 x 4
HG-JR220K24W0C <sup>(Note 3)</sup>	MR-J4-DU55KB4-RJ100 x 4	MR-CV55K4 x 4

Notes: 1. This combination increases the maximum torque from 300% to 400% of the rated torque.

2. The maximum torque can be increased when the "Selection of maximally increasing torque function with drive unit" is enabled with a parameter.

3. Refer to "Compatible Controllers" on p. 1-50 in this catalog for compatible controllers.

MEMO

- Servo Amplifiers
- Rotary Servo Motors**
- Linear Servo Motors
- Direct Drive Motors
- Options/Peripheral Equipment
- LVS/Wires
- Product List
- Precautions

# Rotary Servo Motors

## HG-KR Series (Low Inertia, Small Capacity) Specifications

Rotary servo motor model		HG-KR	053(B)	13(B)	23(B)	43(B)	73(B)
Compatible servo amplifier model		MR-J4- MR-J4W_-	Refer to "Combinations of Rotary Servo Motor and Servo Amplifier" on p. 2-4 in this catalog.				
Power supply capacity <sup>*1</sup>		[kVA]	0.3	0.3	0.5	0.9	1.3
Continuous running duty (Note 6)	Rated output	[W]	50	100	200	400	750
	Rated torque (Note 3)	[N·m]	0.16	0.32	0.64	1.3	2.4
Maximum torque		[N·m]	0.56	1.1	2.2	4.5	8.4
Rated speed (Note 6)		[r/min]	3000				
Maximum speed (Note 6)		[r/min]	6000				
Permissible instantaneous speed		[r/min]	6900				
Power rate at continuous rated torque	Standard	[kW/s]	5.63	13.0	18.3	43.7	45.2
	With electromagnetic brake	[kW/s]	5.37	12.1	16.7	41.3	41.6
Rated current		[A]	0.9	0.8	1.3	2.6	4.8
Maximum current		[A]	3.2	2.5	4.6	9.1	17
Regenerative braking frequency <sup>*2</sup>	MR-J4-	[times/min]	(Note 4)	(Note 4)	453	268	157
	MR-J4W_-	[times/min]	2500	1350	451	268	393
Moment of inertia J	Standard	[× 10 <sup>-4</sup> kg·m <sup>2</sup> ]	0.0450	0.0777	0.221	0.371	1.26
	With electromagnetic brake	[× 10 <sup>-4</sup> kg·m <sup>2</sup> ]	0.0472	0.0837	0.243	0.393	1.37
Recommended load to motor inertia ratio (Note 1)			17 times or less		26 times or less	25 times or less	17 times or less
Speed/position detector			Absolute/incremental 22-bit encoder (resolution: 4194304 pulses/rev)				
Type			Permanent magnet synchronous motor				
Oil seal			None	None (Servo motors with oil seal are available. (HG-KR_J))			
Thermistor			None				
Insulation class			130 (B)				
Structure			Totally enclosed, natural cooling (IP rating: IP65) (Note 2)				
Environment <sup>*3</sup>	Ambient temperature		Operation: 0 °C to 40 °C (non-freezing), storage: -15 °C to 70 °C (non-freezing)				
	Ambient humidity		Operation: 10 %RH to 80 %RH (non-condensing), storage: 10 %RH to 90 %RH (non-condensing)				
	Ambience		Indoors (no direct sunlight); no corrosive gas, inflammable gas, oil mist or dust				
	Altitude		2000 m or less above sea level (Note 5)				
Vibration resistance <sup>*4</sup>			X: 49 m/s <sup>2</sup> Y: 49 m/s <sup>2</sup>				
Vibration rank			V10 <sup>*6</sup>				
Permissible load for the shaft <sup>*5</sup>	L	[mm]	25	25	30	30	40
	Radial	[N]	88	88	245	245	392
	Thrust	[N]	59	59	98	98	147
Mass	Standard	[kg]	0.34	0.54	0.91	1.4	2.8
	With electromagnetic brake	[kg]	0.54	0.74	1.3	1.8	3.8

Notes: 1. Contact your local sales office if the load to motor inertia ratio exceeds the value in the table.

2. The shaft-through portion is excluded. For geared servo motor, IP rating of the gear reducer portion is equivalent to IP44. Refer to the asterisk 7 of "Annotations for Rotary Servo Motor Specifications" on p. 2-41 in this catalog for the shaft-through portion.

3. When unbalanced torque is generated, such as in a vertical lift machine, keep the unbalanced torque of the machine under 70% of the servo motor rated torque.

4. When the servo motor decelerates to a stop from the rated speed, the regenerative frequency will not be limited if the effective torque is within the rated torque range.

When the servo motor decelerates to a stop from the maximum speed, the regenerative frequency will not be limited if the following requirements are met.

• HG-KR053(B): The load to motor inertia ratio is 8 times or less, and the effective torque is within the rated torque range.

• HG-KR13(B): The load to motor inertia ratio is 4 times or less, and the effective torque is within the rated torque range.

5. Refer to "Servo Motor Instruction Manual (Vol. 3)" for the restrictions when using the servo motors at altitude exceeding 1000 m and up to 2000 m above sea level.

6. The continuous running duty and the speed are not guaranteed when the power supply voltage is dropped.

Refer to "Annotations for Rotary Servo Motor Specifications" on p. 2-41 in this catalog for the asterisks 1 to 6.



**HG-KR Series Electromagnetic Brake Specifications** (Note 1)

Model		HG-KR	053B	13B	23B	43B	73B
Type		Spring actuated type safety brake					
Rated voltage		24 V DC <sub>-10%</sub>					
Power consumption [W] at 20 °C		6.3	6.3	7.9	7.9	10	
Electromagnetic brake static friction torque [N·m]		0.32 or higher	0.32 or higher	1.3 or higher	1.3 or higher	2.4 or higher	
Permissible braking work	Per braking [J]	5.6	5.6	22	22	64	
	Per hour [J]	56	56	220	220	640	
Electromagnetic brake life (Note 2)	Number of braking times	20000	20000	20000	20000	20000	
	Work per braking [J]	5.6	5.6	22	22	64	

Notes: 1. The electromagnetic brake is for holding. It cannot be used for deceleration applications.  
 2. Brake gap is not adjustable. Electromagnetic brake life is defined as the time period until readjustment is needed.

**HG-KR Series Torque Characteristics**

**HG-KR053(B)** (Note 1, 2, 3, 4)

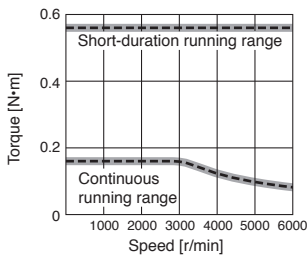

**HG-KR13(B)** (Note 1, 2, 3, 4)

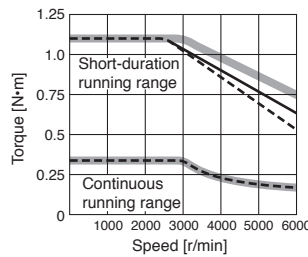

**HG-KR23(B)** (Note 1, 2, 3, 4)

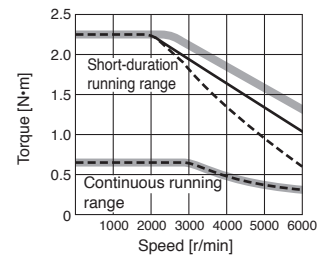

**HG-KR43(B)** (Note 1, 2, 3, 4)

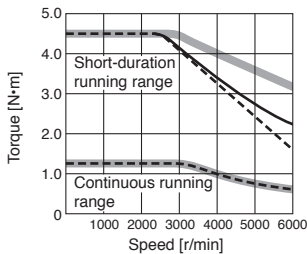

**HG-KR73(B)** (Note 1, 3, 4)

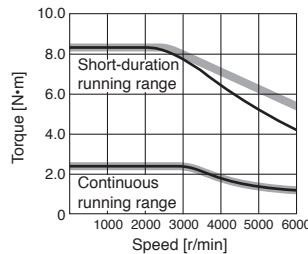

Notes: 1. ——— : For 3-phase 200 V AC or 1-phase 230 V AC.  
 2. - - - - : For 1-phase 100 V AC.  
 3. ——— : For 1-phase 200 V AC.  
 This line is only drawn where it differs from the other two lines.  
 4. Torque drops when the power supply voltage is below the specified value.

**HG-KR Series Special Shaft End Specifications**

Motors with the following specifications are also available.

D-cut shaft (Note 1): 50 W and 100 W

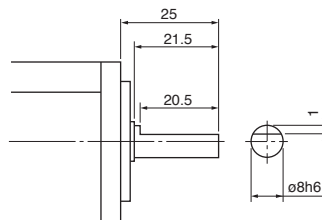

[Unit: mm]

Key shaft (with key) (Note 1, 2): 200 W, 400 W, and 750 W

Model	Variable dimensions								
	T	S	R	Q	W	QK	QL	U	Y
HG-KR23(B)K, 43(B)K	5	14h6	30	26	5	20	3	3	M4 screw Depth: 15
HG-KR73(B)K	6	19h6	40	36	6	25	5	3.5	M5 screw Depth: 20

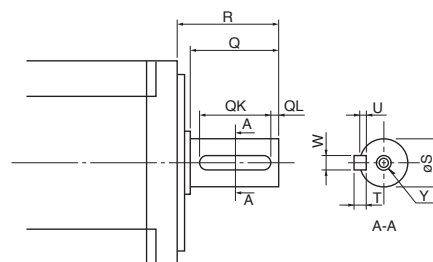

[Unit: mm]

Notes: 1. Do not use servo motors with key shafts for frequent start/stop applications as this may cause damage to the shaft.  
 2. A double round-ended key is attached.

# Rotary Servo Motors

## HG-MR Series (Ultra-Low Inertia, Small Capacity) Specifications

Rotary servo motor model		HG-MR	053(B)	13(B)	23(B)	43(B)	73(B)
Compatible servo amplifier model		MR-J4- MR-J4W_-	Refer to "Combinations of Rotary Servo Motor and Servo Amplifier" on p. 2-4 in this catalog.				
Power supply capacity <sup>*1</sup>		[kVA]	0.3	0.3	0.5	0.9	1.3
Continuous running duty (Note 6)	Rated output	[W]	50	100	200	400	750
	Rated torque (Note 3)	[N·m]	0.16	0.32	0.64	1.3	2.4
Maximum torque		[N·m]	0.48	0.95	1.9	3.8	7.2
Rated speed (Note 6)		[r/min]	3000				
Maximum speed (Note 6)		[r/min]	6000				
Permissible instantaneous speed		[r/min]	6900				
Power rate at continuous rated torque	Standard	[kW/s]	15.6	33.8	46.9	114.2	97.3
	With electromagnetic brake	[kW/s]	11.3	28.0	37.2	98.8	82.1
Rated current		[A]	1.0	0.9	1.5	2.6	5.8
Maximum current		[A]	3.1	2.5	5.3	9.0	20
Regenerative braking frequency <sup>*2</sup>	MR-J4-	[times/min]	(Note 4)	(Note 4)	1180	713	338
	MR-J4W_-	[times/min]	7310	3620	1170	710	846
Moment of inertia J	Standard	[× 10 <sup>-4</sup> kg·m <sup>2</sup> ]	0.0162	0.0300	0.0865	0.142	0.586
	With electromagnetic brake	[× 10 <sup>-4</sup> kg·m <sup>2</sup> ]	0.0224	0.0362	0.109	0.164	0.694
Recommended load to motor inertia ratio (Note 1)			35 times or less	32 times or less			
Speed/position detector			Absolute/incremental 22-bit encoder (resolution: 4194304 pulses/rev)				
Type			Permanent magnet synchronous motor				
Oil seal			None	None (Servo motors with oil seal are available. (HG-MR_J))			
Thermistor			None				
Insulation class			130 (B)				
Structure			Totally enclosed, natural cooling (IP rating: IP65) (Note 2)				
Environment <sup>*3</sup>	Ambient temperature		Operation: 0 °C to 40 °C (non-freezing), storage: -15 °C to 70 °C (non-freezing)				
	Ambient humidity		Operation: 10 %RH to 80 %RH (non-condensing), storage: 10 %RH to 90 %RH (non-condensing)				
	Ambience		Indoors (no direct sunlight); no corrosive gas, inflammable gas, oil mist or dust				
	Altitude		2000 m or less above sea level (Note 5)				
Vibration resistance <sup>*4</sup>			X: 49 m/s <sup>2</sup> Y: 49 m/s <sup>2</sup>				
Vibration rank			V10 <sup>*6</sup>				
Permissible load for the shaft <sup>*5</sup>	L	[mm]	25	25	30	30	40
	Radial	[N]	88	88	245	245	392
	Thrust	[N]	59	59	98	98	147
Mass	Standard	[kg]	0.34	0.54	0.91	1.4	2.8
	With electromagnetic brake	[kg]	0.54	0.74	1.3	1.8	3.8

Notes: 1. Contact your local sales office if the load to motor inertia ratio exceeds the value in the table.

2. The shaft-through portion is excluded. Refer to the asterisk 7 of "Annotations for Rotary Servo Motor Specifications" on p. 2-41 in this catalog for the shaft-through portion.

3. When unbalanced torque is generated, such as in a vertical lift machine, keep the unbalanced torque of the machine under 70% of the servo motor rated torque.

4. When the servo motor decelerates to a stop from the rated speed, the regenerative frequency will not be limited if the effective torque is within the rated torque range.

When the servo motor decelerates to a stop from the maximum speed, the regenerative frequency will not be limited if the following requirements are met.

- HG-MR053(B): The load to motor inertia ratio is 24 times or less, and the effective torque is within the rated torque range.

- HG-MR13(B): The load to motor inertia ratio is 12 times or less, and the effective torque is within the rated torque range.

5. Refer to "Servo Motor Instruction Manual (Vol. 3)" for the restrictions when using the servo motors at altitude exceeding 1000 m and up to 2000 m above sea level.

6. The continuous running duty and the speed are not guaranteed when the power supply voltage is dropped.

Refer to "Annotations for Rotary Servo Motor Specifications" on p. 2-41 in this catalog for the asterisks 1 to 6.

**HG-MR Series Electromagnetic Brake Specifications (Note 1)**

Model	HG-MR	053B	13B	23B	43B	73B
Type	Spring actuated type safety brake					
Rated voltage	24 V DC <sup>-10%</sup>					
Power consumption [W] at 20 °C		6.3	6.3	7.9	7.9	10
Electromagnetic brake static friction torque [N·m]		0.32 or higher	0.32 or higher	1.3 or higher	1.3 or higher	2.4 or higher
Permissible braking work	Per braking [J]	5.6	5.6	22	22	64
	Per hour [J]	56	56	220	220	640
Electromagnetic brake life (Note 2)	Number of braking times	20000	20000	20000	20000	20000
	Work per braking [J]	5.6	5.6	22	22	64

Notes: 1. The electromagnetic brake is for holding. It cannot be used for deceleration applications.  
 2. Brake gap is not adjustable. Electromagnetic brake life is defined as the time period until readjustment is needed.

**HG-MR Series Torque Characteristics**

**HG-MR053(B)** (Note 1, 2, 3, 4)

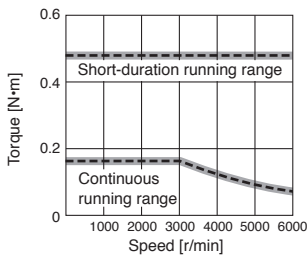

**HG-MR13(B)** (Note 1, 2, 3, 4)

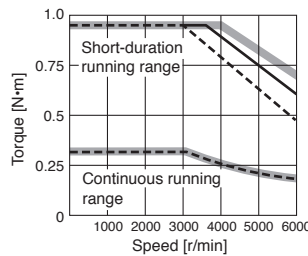

**HG-MR23(B)** (Note 1, 2, 3, 4)

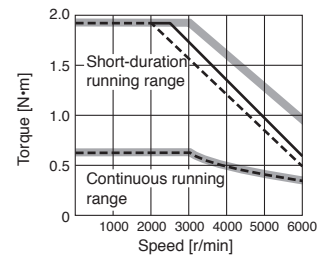

**HG-MR43(B)** (Note 1, 2, 3, 4)

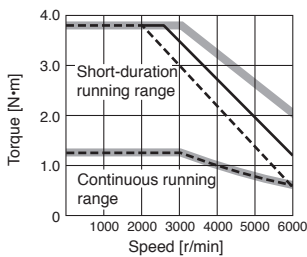

**HG-MR73(B)** (Note 1, 3, 4)

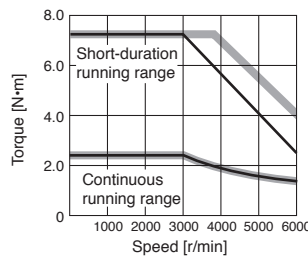

Notes: 1. ——— : For 3-phase 200 V AC or 1-phase 230 V AC.  
 2. - - - - : For 1-phase 100 V AC.  
 3. ——— : For 1-phase 200 V AC.  
 This line is only drawn where it differs from the other two lines.  
 4. Torque drops when the power supply voltage is below the specified value.

**HG-MR Series Special Shaft End Specifications**

Motors with the following specifications are also available.

D-cut shaft (Note 1): 50 W and 100 W

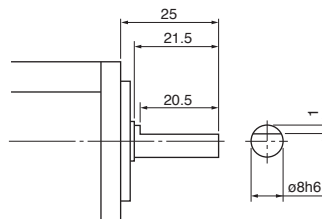

[Unit: mm]

Key shaft (with key) (Note 1, 2): 200 W, 400 W, and 750 W

Model	Variable dimensions								
	T	S	R	Q	W	QK	QL	U	Y
HG-MR23(B)K, 43(B)K	5	14h6	30	26	5	20	3	3	M4 screw Depth: 15
HG-MR73(B)K	6	19h6	40	36	6	25	5	3.5	M5 screw Depth: 20

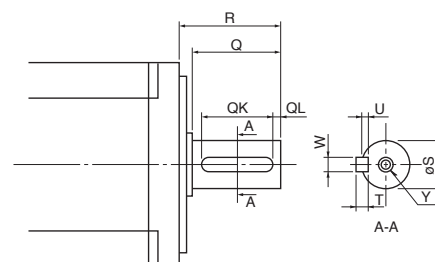

[Unit: mm]

Notes: 1. Do not use servo motors with key shafts for frequent start/stop applications as this may cause damage to the shaft.  
 2. A double round-ended key is attached.

# Rotary Servo Motors

## HG-SR 1000 r/min Series (Medium Inertia, Medium Capacity) Specifications

Rotary servo motor model		HG-SR	51(B)	81(B)	121(B)	201(B)	301(B)	421(B)
Compatible servo amplifier model		MR-J4- MR-J4W_-	Refer to "Combinations of Rotary Servo Motor and Servo Amplifier" on p. 2-4 in this catalog.					
Power supply capacity <sup>1</sup>		[kVA]	1.0	1.5	2.1	3.5	4.8	6.3
Continuous running duty (Note 5)	Rated output	[kW]	0.5	0.85	1.2	2.0	3.0	4.2
	Rated torque (Note 3)	[N·m]	4.8	8.1	11.5	19.1	28.6	40.1
Maximum torque		[N·m]	14.3	24.4	34.4	57.3	85.9	120
Rated speed (Note 5)		[r/min]	1000					
Maximum speed (Note 5)		[r/min]	1500					
Permissible instantaneous speed		[r/min]	1725					
Power rate at continuous rated torque	Standard	[kW/s]	19.7	41.2	28.1	46.4	82.3	107
	With electromagnetic brake	[kW/s]	16.5	36.2	23.2	41.4	75.3	99.9
Rated current		[A]	2.8	5.2	7.1	9.4	13	19
Maximum current		[A]	9.0	17	23	30	42	61
Regenerative braking frequency <sup>2</sup>	MR-J4-	[times/min]	77	114	191	113	89	76
	MR-J4W_-	[times/min]	392	286	-	-	-	-
Moment of inertia J	Standard	[ $\times 10^{-4}$ kg·m <sup>2</sup> ]	11.6	16.0	46.8	78.6	99.7	151
	With electromagnetic brake	[ $\times 10^{-4}$ kg·m <sup>2</sup> ]	13.8	18.2	56.5	88.2	109	161
Recommended load to motor inertia ratio (Note 1)			17 times or less			15 times or less		
Speed/position detector			Absolute/incremental 22-bit encoder (resolution: 4194304 pulses/rev)					
Type			Permanent magnet synchronous motor					
Oil seal			None (Servo motors with oil seal are available. (HG-SR_J))					
Thermistor			None					
Insulation class			155 (F)					
Structure			Totally enclosed, natural cooling (IP rating: IP67) (Note 2)					
Environment <sup>3</sup>	Ambient temperature		Operation: 0 °C to 40 °C (non-freezing), storage: -15 °C to 70 °C (non-freezing)					
	Ambient humidity		Operation: 10 %RH to 80 %RH (non-condensing), storage: 10 %RH to 90 %RH (non-condensing)					
	Ambience		Indoors (no direct sunlight); no corrosive gas, inflammable gas, oil mist or dust					
	Altitude		2000 m or less above sea level (Note 4)					
Vibration resistance <sup>4</sup>			X: 24.5 m/s <sup>2</sup> Y: 24.5 m/s <sup>2</sup>		X: 24.5 m/s <sup>2</sup> Y: 49 m/s <sup>2</sup>		X: 24.5 m/s <sup>2</sup> Y: 29.4 m/s <sup>2</sup>	
Vibration rank			V10 <sup>5</sup>					
Permissible load for the shaft <sup>5</sup>	L	[mm]	55	55	79	79	79	79
	Radial	[N]	980	980	2058	2058	2058	2058
	Thrust	[N]	490	490	980	980	980	980
Mass	Standard	[kg]	6.2	7.3	11	16	20	27
	With electromagnetic brake	[kg]	8.2	9.3	17	22	26	33

Notes: 1. Contact your local sales office if the load to motor inertia ratio exceeds the value in the table.

2. The shaft-through portion is excluded. The servo motor with oil seal is rated IP67 as well (excluding the shaft-through portion). Refer to the asterisk 7 of "Annotations for Rotary Servo Motor Specifications" on p. 2-41 in this catalog for the shaft-through portion.

3. When unbalanced torque is generated, such as in a vertical lift machine, keep the unbalanced torque of the machine under 70% of the servo motor rated torque.

4. Refer to "Servo Motor Instruction Manual (Vol. 3)" for the restrictions when using the servo motors at altitude exceeding 1000 m and up to 2000 m above sea level.

5. The continuous running duty and the speed are not guaranteed when the power supply voltage is dropped.

Refer to "Annotations for Rotary Servo Motor Specifications" on p. 2-41 in this catalog for the asterisks 1 to 6.

**HG-SR 1000 r/min Series Electromagnetic Brake Specifications (Note 1)**

Model	HG-SR	51B	81B	121B	201B	301B	421B
Type	Spring actuated type safety brake						
Rated voltage	24 V DC <sub>-10%</sub>						
Power consumption [W] at 20 °C		20	20	34	34	34	34
Electromagnetic brake static friction torque [N·m]		8.5 or higher	8.5 or higher	44 or higher	44 or higher	44 or higher	44 or higher
Permissible braking work	Per braking [J]	400	400	4500	4500	4500	4500
	Per hour [J]	4000	4000	45000	45000	45000	45000
Electromagnetic brake life (Note 2)	Number of braking times	20000	20000	20000	20000	20000	20000
	Work per braking [J]	200	200	1000	1000	1000	1000

Notes: 1. The electromagnetic brake is for holding. It cannot be used for deceleration applications.  
 2. Brake gap is not adjustable. Electromagnetic brake life is defined as the time period until readjustment is needed.

**HG-SR 1000 r/min Series Torque Characteristics**

**HG-SR51(B)** (Note 1, 2, 3, 4)

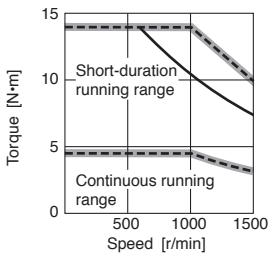

**HG-SR81(B)** (Note 1, 3, 4, 5)

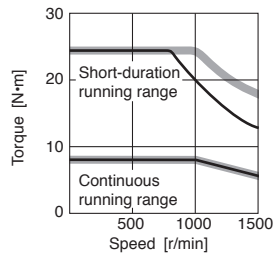

**HG-SR121(B)** (Note 1, 3, 4, 5)

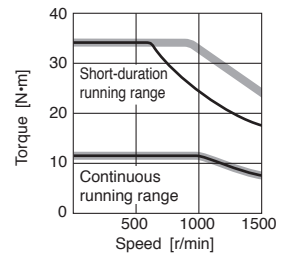

**HG-SR201(B)** (Note 1, 3, 4, 5)

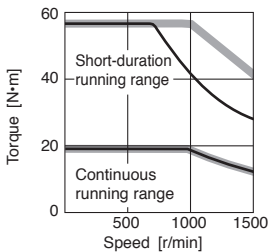

**HG-SR301(B)** (Note 1, 4)

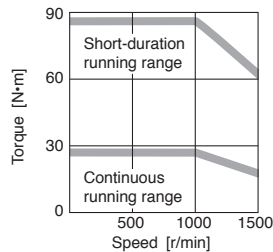

**HG-SR421(B)** (Note 1, 4)

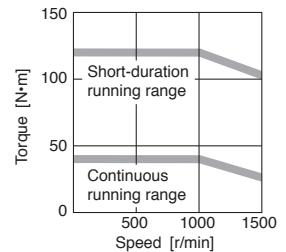

Notes: 1. — : For 3-phase 200 V AC.  
 2. - - - : For 1-phase 230 V AC.  
 3. — : For 1-phase 200 V AC. This line is only drawn where it differs from the other two lines.  
 4. Torque drops when the power supply voltage is below the specified value.  
 5. When using a combination of the servo motors and MR-J4-100\_ or MR-J4-200\_ with a 1-phase power supply, use the servo amplifiers at 75 % or less of the effective load ratio.

**HG-SR 1000 r/min Series Special Shaft End Specifications**

Motors with the following specifications are also available.

Key shaft (without key) (Note 1, 2)

Model	Variable dimensions								
	S	R	Q	W	QK	QL	U	r	Y
HG-SR51(B)K, 81(B)K	24h6	55	50	8 <sup>0</sup> <sub>-0.036</sub>	36	5	4 <sup>+0.2</sup> <sub>0</sub>	4	M8 screw Depth: 20
HG-SR121(B)K, 201(B)K, 301(B)K, 421(B)K	35 <sup>+0.010</sup> <sub>0</sub>	79	75	10 <sup>0</sup> <sub>-0.036</sub>	55	5	5 <sup>+0.2</sup> <sub>0</sub>	5	

Notes: 1. Do not use servo motors with key shafts for frequent start/stop applications as this may cause damage to the shaft.  
 2. A key is not supplied with the servo motor. The key shall be installed by the user.

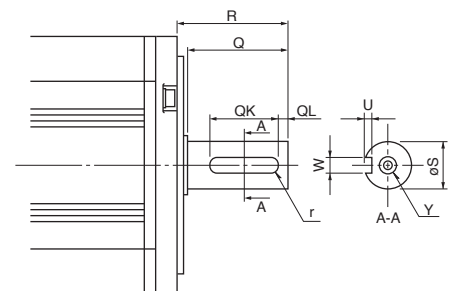

[Unit: mm]

Servo Amplifiers  
 Rotary Servo Motors  
 Linear Servo Motors  
 Direct Drive Motors  
 Options/Peripheral Equipment  
 LV5/Wires  
 Product List  
 Precautions

# Rotary Servo Motors

## HG-SR 2000 r/min Series (Medium Inertia, Medium Capacity) (200 V Class) Specifications

Rotary servo motor model		HG-SR	52(B)	102(B)	152(B)	202(B)	352(B)	502(B)	702(B)
Compatible servo amplifier model		MR-J4- MR-J4W_-	Refer to "Combinations of Rotary Servo Motor and Servo Amplifier" on p. 2-4 in this catalog.						
Power supply capacity <sup>*1</sup>		[kVA]	1.0	1.7	2.5	3.5	5.5	7.5	10
Continuous running duty (Note 7)	Rated output	[kW]	0.5	1.0	1.5	2.0	3.5	5.0	7.0
	Rated torque (Note 3)	[N·m]	2.4	4.8	7.2	9.5	16.7	23.9	33.4
Maximum torque		[N·m]	7.2	14.3	21.5	28.6	50.1	71.6	100 <134> (Note 5)
Rated speed (Note 7)		[r/min]	2000						
Maximum speed (Note 7)		[r/min]	3000						
Permissible instantaneous speed		[r/min]	3450						
Power rate at continuous rated torque	Standard	[kW/s]	7.85	19.7	32.1	19.5	35.5	57.2	74.0
	With electromagnetic brake	[kW/s]	6.01	16.5	28.2	16.1	31.7	52.3	69.4
Rated current		[A]	2.9	5.6	9.4	9.6	14	22	26
Maximum current		[A]	9.0	17	29	31	45	70	83 <116> (Note 5)
Regenerative braking frequency <sup>*2</sup>	MR-J4-	[times/min]	31	38	139	47	28	29	25 (Note 6)
	MR-J4W_-	[times/min]	154	96	-	-	-	-	-
Moment of inertia J	Standard	[× 10 <sup>-4</sup> kg·m <sup>2</sup> ]	7.26	11.6	16.0	46.8	78.6	99.7	151
	With electromagnetic brake	[× 10 <sup>-4</sup> kg·m <sup>2</sup> ]	9.48	13.8	18.2	56.5	88.2	109	161
Recommended load to motor inertia ratio (Note 1)			15 times or less	17 times or less		15 times or less			
Speed/position detector			Absolute/incremental 22-bit encoder (resolution: 4194304 pulses/rev)						
Type			Permanent magnet synchronous motor						
Oil seal			None (Servo motors with oil seal are available. (HG-SR_J))						
Thermistor			None						
Insulation class			155 (F)						
Structure			Totally enclosed, natural cooling (IP rating: IP67) (Note 2)						
Environment <sup>*3</sup>	Ambient temperature		Operation: 0 °C to 40 °C (non-freezing), storage: -15 °C to 70 °C (non-freezing)						
	Ambient humidity		Operation: 10 %RH to 80 %RH (non-condensing), storage: 10 %RH to 90 %RH (non-condensing)						
	Ambience		Indoors (no direct sunlight); no corrosive gas, inflammable gas, oil mist or dust						
	Altitude		2000 m or less above sea level (Note 4)						
Vibration resistance <sup>*4</sup>			X: 24.5 m/s <sup>2</sup> Y: 24.5 m/s <sup>2</sup>			X: 24.5 m/s <sup>2</sup> Y: 49 m/s <sup>2</sup>		X: 24.5 m/s <sup>2</sup> Y: 29.4 m/s <sup>2</sup>	
Vibration rank			V10 <sup>*6</sup>						
Permissible load for the shaft <sup>*5</sup>	L	[mm]	55	55	55	79	79	79	79
	Radial	[N]	980	980	980	2058	2058	2058	2058
	Thrust	[N]	490	490	490	980	980	980	980
Mass	Standard	[kg]	4.8	6.2	7.3	11	16	20	27
	With electromagnetic brake	[kg]	6.7	8.2	9.3	17	22	26	33

Notes: 1. Contact your local sales office if the load to motor inertia ratio exceeds the value in the table.

2. The shaft-through portion is excluded. The servo motor with oil seal is rated IP67 as well (excluding the shaft-through portion), and for geared servo motor, IP rating of the gear reducer portion is equivalent to IP44. Refer to the asterisk 7 of "Annotations for Rotary Servo Motor Specifications" on p. 2-41 in this catalog for the shaft-through portion.

3. When unbalanced torque is generated, such as in a vertical lift machine, keep the unbalanced torque of the machine under 70% of the servo motor rated torque.

4. Refer to "Servo Motor Instruction Manual (Vol. 3)" for the restrictions when using the servo motors at altitude exceeding 1000 m and up to 2000 m above sea level.

5. The value in angle brackets is applicable when the servo motor is combined with MR-J4-DU900B(-RJ) drive unit, and the maximum torque is increased with a parameter setting.

6. This value is applicable when the servo motor is combined with MR-J4-700GF(-RJ)/MR-J4-700B(-RJ)/MR-J4-700A(-RJ) servo amplifier. Contact your local sales office for the regenerative braking frequency with MR-J4-DU900B(-RJ) drive unit.

7. The continuous running duty and the speed are not guaranteed when the power supply voltage is dropped.

Refer to "Annotations for Rotary Servo Motor Specifications" on p. 2-41 in this catalog for the asterisks 1 to 6.

**HG-SR 2000 r/min Series (200 V Class) Electromagnetic Brake Specifications (Note 1)**

Model		HG-SR	52B	102B	152B	202B	352B	502B	702B
Type		Spring actuated type safety brake							
Rated voltage		24 V DC <sub>-10%</sub>							
Power consumption [W] at 20 °C		20	20	20	34	34	34	34	34
Electromagnetic brake static friction torque [N·m]		8.5 or higher	8.5 or higher	8.5 or higher	44 or higher	44 or higher	44 or higher	44 or higher	44 or higher
Permissible braking work	Per braking [J]	400	400	400	4500	4500	4500	4500	4500
	Per hour [J]	4000	4000	4000	45000	45000	45000	45000	45000
Electromagnetic brake life (Note 2)	Number of braking times	20000	20000	20000	20000	20000	20000	20000	20000
	Work per braking [J]	200	200	200	1000	1000	1000	1000	1000

Notes: 1. The electromagnetic brake is for holding. It cannot be used for deceleration applications.  
 2. Brake gap is not adjustable. Electromagnetic brake life is defined as the time period until readjustment is needed.

**HG-SR 2000 r/min Series (200 V Class) Torque Characteristics**

**HG-SR52(B)** (Note 1, 2, 3, 4)

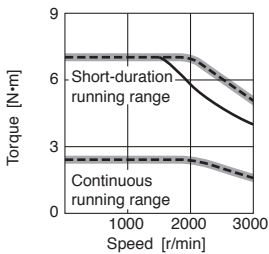

**HG-SR102(B)** (Note 1, 2, 3, 4, 6)

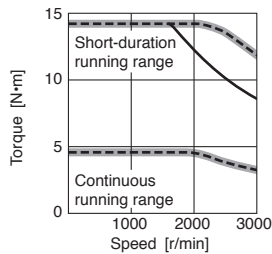

**HG-SR152(B)** (Note 1, 2, 3, 4, 6)

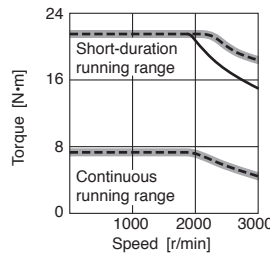

**HG-SR202(B)** (Note 1, 2, 3, 4, 6)

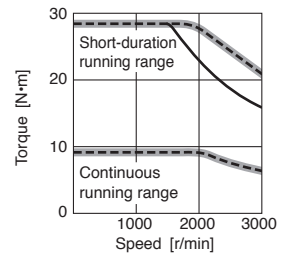

**HG-SR352(B)** (Note 1, 4)

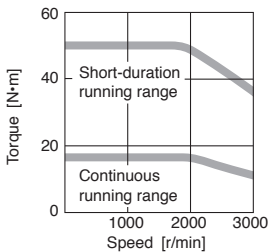

**HG-SR502(B)** (Note 1, 4)

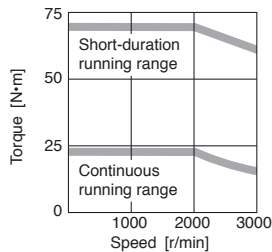

**HG-SR702(B)** (Note 1, 4)

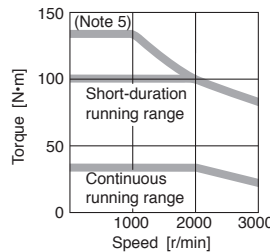

- Notes: 1. — : For 3-phase 200 V AC.  
 2. - - - : For 1-phase 230 V AC.  
 3. — : For 1-phase 200 V AC. This line is only drawn where it differs from the other two lines.  
 4. Torque drops when the power supply voltage is below the specified value.  
 5. This value is applicable when the servo motor is combined with MR-J4-DU900B(-RJ) drive unit, and the maximum torque is increased with a parameter setting.  
 6. When using a combination of the servo motors and MR-J4-100\_ or MR-J4-200\_ with a 1-phase power supply, use the servo amplifiers at 75 % or less of the effective load ratio.

**HG-SR 2000 r/min Series (200 V Class) Special Shaft End Specifications**

Motors with the following specifications are also available.

Key shaft (without key) (Note 1, 2)

Model	Variable dimensions								
	S	R	Q	W	QK	QL	U	r	Y
HG-SR52(B)K, 102(B)K, 152(B)K	24h6	55	50	8 <sup>0</sup> <sub>-0.036</sub>	36	5	4 <sup>+0.2</sup> <sub>0</sub>	4	M8 screw Depth: 20
HG-SR202(B)K, 352(B)K, 502(B)K, 702(B)K	35 <sup>+0.010</sup> <sub>0</sub>	79	75	10 <sup>0</sup> <sub>-0.036</sub>	55	5	5 <sup>+0.2</sup> <sub>0</sub>	5	

- Notes: 1. Do not use servo motors with key shafts for frequent start/stop applications as this may cause damage to the shaft.  
 2. A key is not supplied with the servo motor. The key shall be installed by the user.

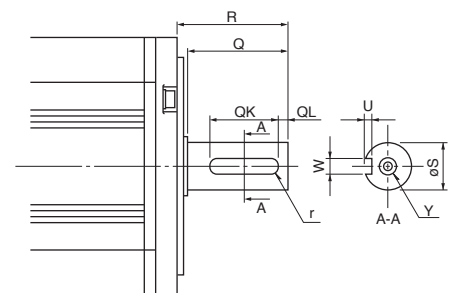

[Unit: mm]

Servo Amplifiers  
 Rotary Servo Motors  
 Linear Servo Motors  
 Direct Drive Motors  
 Options/Peripheral Equipment  
 LV5/Wires  
 Product List  
 Precautions

# Rotary Servo Motors

## HG-SR 2000 r/min Series (Medium Inertia, Medium Capacity) (400 V Class) Specifications

Rotary servo motor model		HG-SR	524(B)	1024(B)	1524(B)	2024(B)	3524(B)	5024(B)	7024(B)
Compatible servo amplifier model		MR-J4-	Refer to "Combinations of Rotary Servo Motor and Servo Amplifier" on p. 2-6 in this catalog.						
Power supply capacity <sup>*1</sup>		[kVA]	1.0	1.7	2.5	3.5	5.5	7.5	10
Continuous running duty (Note 7)	Rated output	[kW]	0.5	1.0	1.5	2.0	3.5	5.0	7.0
	Rated torque (Note 3)	[N·m]	2.4	4.8	7.2	9.5	16.7	23.9	33.4
Maximum torque		[N·m]	7.2	14.3	21.5	28.6	50.1	71.6	100 <134> (Note 5)
Rated speed (Note 7)		[r/min]	2000						
Maximum speed (Note 7)		[r/min]	3000						
Permissible instantaneous speed		[r/min]	3450						
Power rate at continuous rated torque	Standard	[kW/s]	7.85	19.7	32.1	19.5	35.5	57.2	74.0
	With electromagnetic brake	[kW/s]	6.01	16.5	28.2	16.1	31.7	52.3	69.4
Rated current		[A]	1.5	2.8	4.7	4.9	7.0	11	13
Maximum current		[A]	4.5	8.9	17	17	27	42	59 <59> (Note 5)
Regenerative braking frequency <sup>*2</sup>	MR-J4-	[times/min]	46	29	139	47	34	29	25 (Note 6)
Moment of inertia J	Standard	[× 10 <sup>-4</sup> kg·m <sup>2</sup> ]	7.26	11.6	16.0	46.8	78.6	99.7	151
	With electromagnetic brake	[× 10 <sup>-4</sup> kg·m <sup>2</sup> ]	9.48	13.8	18.2	56.5	88.2	109	161
Recommended load to motor inertia ratio (Note 1)			15 times or less	17 times or less		15 times or less			
Speed/position detector			Absolute/incremental 22-bit encoder (resolution: 4194304 pulses/rev)						
Type			Permanent magnet synchronous motor						
Oil seal			None (Servo motors with oil seal are available. (HG-SR_J))						
Thermistor			None						
Insulation class			155 (F)						
Structure			Totally enclosed, natural cooling (IP rating: IP67) (Note 2)						
Environment <sup>*3</sup>	Ambient temperature		Operation: 0 °C to 40 °C (non-freezing), storage: -15 °C to 70 °C (non-freezing)						
	Ambient humidity		Operation: 10 %RH to 80 %RH (non-condensing), storage: 10 %RH to 90 %RH (non-condensing)						
	Ambience		Indoors (no direct sunlight); no corrosive gas, inflammable gas, oil mist or dust						
	Altitude		2000 m or less above sea level (Note 4)						
Vibration resistance <sup>*4</sup>			X: 24.5 m/s <sup>2</sup> Y: 24.5 m/s <sup>2</sup>			X: 24.5 m/s <sup>2</sup> Y: 49 m/s <sup>2</sup>		X: 24.5 m/s <sup>2</sup> Y: 29.4 m/s <sup>2</sup>	
Vibration rank			V10 <sup>*6</sup>						
Permissible load for the shaft <sup>*5</sup>	L	[mm]	55	55	55	79	79	79	79
	Radial	[N]	980	980	980	2058	2058	2058	2058
	Thrust	[N]	490	490	490	980	980	980	980
Mass	Standard	[kg]	4.8	6.2	7.3	11	16	20	27
	With electromagnetic brake	[kg]	6.7	8.2	9.3	17	22	26	33

Notes: 1. Contact your local sales office if the load to motor inertia ratio exceeds the value in the table.

2. The shaft-through portion is excluded. The servo motor with oil seal is rated IP67 as well (excluding the shaft-through portion), and for geared servo motor, IP rating of the gear reducer portion is equivalent to IP44. Refer to the asterisk 7 of "Annotations for Rotary Servo Motor Specifications" on p. 2-41 in this catalog for the shaft-through portion.

3. When unbalanced torque is generated, such as in a vertical lift machine, keep the unbalanced torque of the machine under 70% of the servo motor rated torque.

4. Refer to "Servo Motor Instruction Manual (Vol. 3)" for the restrictions when using the servo motors at altitude exceeding 1000 m and up to 2000 m above sea level.

5. The value in angle brackets is applicable when the servo motor is combined with MR-J4-DU900B4(-RJ) drive unit, and the maximum torque is increased with a parameter setting.

6. This value is applicable when the servo motor is combined with MR-J4-700GF4(-RJ)/MR-J4-700B4(-RJ)/MR-J4-700A4(-RJ) servo amplifier. Contact your local sales office for the regenerative braking frequency with MR-J4-DU900B4(-RJ) drive unit.

7. The continuous running duty and the speed are not guaranteed when the power supply voltage is dropped.

Refer to "Annotations for Rotary Servo Motor Specifications" on p. 2-41 in this catalog for the asterisks 1 to 6.



**HG-SR 2000 r/min Series (400 V Class) Electromagnetic Brake Specifications** (Note 1)

Model	HG-SR	524B	1024B	1524B	2024B	3524B	5024B	7024B
Type	Spring actuated type safety brake							
Rated voltage	24 V DC <sub>-10%</sub>							
Power consumption [W] at 20 °C		20	20	20	34	34	34	34
Electromagnetic brake static friction torque [N·m]		8.5 or higher	8.5 or higher	8.5 or higher	44 or higher	44 or higher	44 or higher	44 or higher
Permissible braking work	Per braking [J]	400	400	400	4500	4500	4500	4500
	Per hour [J]	4000	4000	4000	45000	45000	45000	45000
Electromagnetic brake life (Note 2)	Number of braking times	20000	20000	20000	20000	20000	20000	20000
	Work per braking [J]	200	200	200	1000	1000	1000	1000

Notes: 1. The electromagnetic brake is for holding. It cannot be used for deceleration applications.  
 2. Brake gap is not adjustable. Electromagnetic brake life is defined as the time period until readjustment is needed.

**HG-SR 2000 r/min Series (400 V Class) Torque Characteristics**

**HG-SR524(B)** (Note 1, 2, 3)

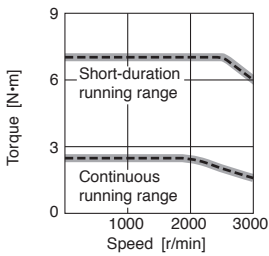

**HG-SR1024(B)** (Note 1, 2, 3)

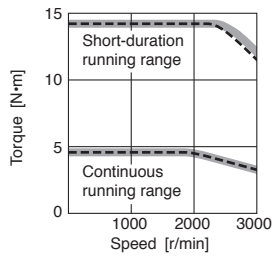

**HG-SR1524(B)** (Note 1, 2, 3)

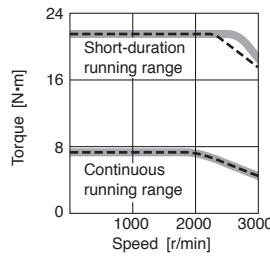

**HG-SR2024(B)** (Note 1, 2, 3)

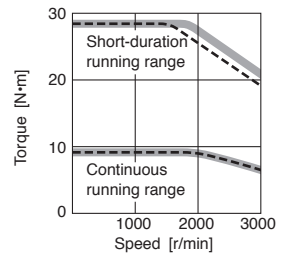

**HG-SR3524(B)** (Note 1, 2, 3)

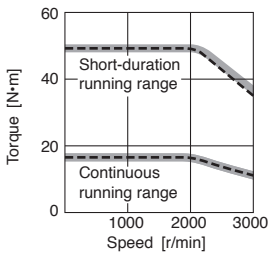

**HG-SR5024(B)** (Note 1, 2, 3)

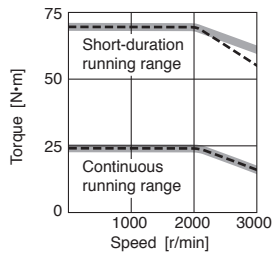

**HG-SR7024(B)** (Note 1, 2, 3)

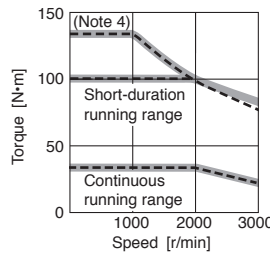

Notes: 1. — : For 3-phase 400 V AC.  
 2. - - - : For 3-phase 380 V AC.  
 3. Torque drops when the power supply voltage is below the specified value.  
 4. This value is applicable when the servo motor is combined with MR-J4-DU900B4(-RJ) drive unit, and the maximum torque is increased with a parameter setting.

**HG-SR 2000 r/min Series (400 V Class) Special Shaft End Specifications**

Motors with the following specifications are also available.

Key shaft (without key) (Note 1, 2)

Model	Variable dimensions								
	S	R	Q	W	QK	QL	U	r	Y
HG-SR524(B)K, 1024(B)K, 1524(B)K	24h6	55	50	8 <sup>0</sup> <sub>-0.036</sub>	36	5	4 <sup>+0.2</sup> <sub>0</sub>	4	M8 screw Depth: 20
HG-SR2024(B)K, 3524(B)K, 5024(B)K, 7024(B)K	35 <sup>+0.010</sup> <sub>0</sub>	79	75	10 <sup>0</sup> <sub>-0.036</sub>	55	5	5 <sup>+0.2</sup> <sub>0</sub>	5	

Notes: 1. Do not use servo motors with key shafts for frequent start/stop applications as this may cause damage to the shaft.  
 2. A key is not supplied with the servo motor. The key shall be installed by the user.

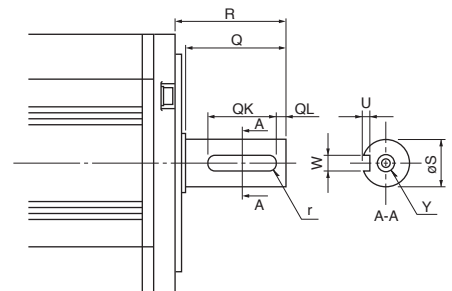

[Unit: mm]

Servo Amplifiers  
 Rotary Servo Motors  
 Linear Servo Motors  
 Direct Drive Motors  
 Options/Peripheral Equipment  
 LV5/Wires  
 Product List  
 Precautions

# Rotary Servo Motors

## HG-JR 3000 r/min Series (Low Inertia, Medium Capacity) (200 V Class) Specifications

Rotary servo motor model		HG-JR	53(B)	73(B)	103(B)	153(B)	203(B)	353(B)	503(B)	703(B)	903(B)	
Compatible servo amplifier model		MR-J4- MR-J4W_	Refer to "Combinations of Rotary Servo Motor and Servo Amplifier" on pp. 2-4 and 2-5 in this catalog.									
Power supply capacity <sup>*1</sup>		[kVA]	1.0	1.3	1.7	2.5	3.5	5.5	7.5	10	13	
Continuous running duty (Note 10)	Rated output	[kW]	0.5	0.75	1.0	1.5	2.0	3.3 <3.5> (Note 4)	5.0	7.0	9.0	
	Rated torque (Note 3)	[N·m]	1.6	2.4	3.2	4.8	6.4	10.5 <11.1> (Note 4)	15.9	22.3	28.6	
Maximum torque		[N·m]	4.8 <6.4> (Note 5)	7.2 <9.6> (Note 5)	9.6 <12.7> (Note 5)	14.3 <19.1> (Note 5)	19.1 <25.5> (Note 5)	32.0 <44.6> (Note 5)	47.7 <63.7> (Note 5)	66.8 <78.0> (Note 8)	85.8	
Rated speed (Note 10)		[r/min]	3000									
Maximum speed (Note 10)		[r/min]	6000						5000			
Permissible instantaneous speed		[r/min]	6900						5750			
Power rate at continuous rated torque	Standard	[kW/s]	16.7	27.3	38.2	60.2	82.4	83.5	133	115	147	
	With electromagnetic brake	[kW/s]	12.5	22.0	32.2	53.1	74.8	71.6	119	93.9	125	
Rated current		[A]	3.0	5.6	5.6	11	11	17 <18> (Note 4)	27	34	41	
Maximum current		[A]	9.0 <12> (Note 5)	17 <23> (Note 5)	17 <23> (Note 5)	32 <43> (Note 5)	32 <43> (Note 5)	51 <71> (Note 5)	81 <108> (Note 5)	103 <134> (Note 8)	134	
Regenerative braking frequency <sup>*2</sup>	MR-J4-	[times/min]	67 <137> (Note 5)	98 <511> (Note 5)	76 <396> (Note 5)	271 <271> (Note 5)	206 <206> (Note 5)	73 <98> (Note 5)	68 <89> (Note 5, 9)	56 (Note 9)	204 (Note 6, 9)	
	MR-J4W_	[times/min]	328 <328> (Note 5)	237	186	-	-	-	-	-	-	
Moment of inertia J	Standard	[× 10 <sup>-4</sup> kg·m <sup>2</sup> ]	1.52	2.09	2.65	3.79	4.92	13.2	19.0	43.3	55.8	
	With electromagnetic brake	[× 10 <sup>-4</sup> kg·m <sup>2</sup> ]	2.02	2.59	3.15	4.29	5.42	15.4	21.2	52.9	65.4	
Recommended load to motor inertia ratio (Note 1)			10 times or less									
Speed/position detector			Absolute/incremental 22-bit encoder (resolution: 4194304 pulses/rev)									
Type			Permanent magnet synchronous motor									
Oil seal			Installed									
Thermistor			None									
Insulation class			155 (F)									
Structure			Totally enclosed, natural cooling (IP rating: IP67) (Note 2)									
Environment <sup>*3</sup>	Ambient temperature		Operation: 0 °C to 40 °C (non-freezing), storage: -15 °C to 70 °C (non-freezing)									
	Ambient humidity		Operation: 10 %RH to 80 %RH (non-condensing), storage: 10 %RH to 90 %RH (non-condensing)									
	Ambience		Indoors (no direct sunlight); no corrosive gas, inflammable gas, oil mist or dust									
	Altitude		2000 m or less above sea level (Note 7)									
Vibration resistance <sup>*4</sup>			X: 24.5 m/s <sup>2</sup> Y: 24.5 m/s <sup>2</sup>							X: 24.5 m/s <sup>2</sup> Y: 29.4 m/s <sup>2</sup>		
Vibration rank			V10 <sup>*6</sup>									
Permissible load for the shaft <sup>*5</sup>	L	[mm]	40	40	40	40	40	55	55	79	79	
	Radial	[N]	323	323	323	323	323	980	980	2450	2450	
	Thrust	[N]	284	284	284	284	284	490	490	980	980	
Mass	Standard	[kg]	3.0	3.7	4.5	5.9	7.5	13	18	29	36	
	With electromagnetic brake	[kg]	4.4	5.1	5.9	7.3	8.9	15	20	35	42	

Notes: 1. Contact your local sales office if the load to motor inertia ratio exceeds the value in the table.

2. The shaft-through portion is excluded. Refer to the asterisk 7 of "Annotations for Rotary Servo Motor Specifications" on p. 2-41 in this catalog for the shaft-through portion.

3. When unbalanced torque is generated, such as in a vertical lift machine, keep the unbalanced torque of the machine under 70% of the servo motor rated torque.

4. The value in angle brackets is applicable when the servo motor is combined with MR-J4-500GF(-RJ)/MR-J4-500B(-RJ)/MR-J4-500A(-RJ) servo amplifier.

5. The value in angle brackets is applicable when the maximum torque is increased with a combination with a larger-capacity servo amplifier. Refer to "Combinations of HG-JR Servo Motor Series and Servo Amplifier (200 V/400 V Class) for Increasing the Maximum Torque to 400% of the Rated Torque" on p. 2-7 in this catalog for the available combinations.

6. This value is applicable when the external regenerative resistors, GRZG400-Ω (standard accessory) are used with cooling fans (two units of 92 mm × 92 mm, minimum airflow: 1.0 m<sup>3</sup>/min). Note that [Pr. PA02] must be changed.

7. Refer to "Servo Motor Instruction Manual (Vol. 3)" for the restrictions when using the servo motors at altitude exceeding 1000 m and up to 2000 m above sea level.

8. The value in angle brackets is applicable when the servo motor is combined with MR-J4-DU900B(-RJ) drive unit, and the maximum torque is increased with a parameter setting.

9. This value is applicable when the servo motor is combined with MR-J4-GF(-RJ)/MR-J4-B(-RJ)/MR-J4-A(-RJ) servo amplifier. Contact your local sales office for the regenerative braking frequency with MR-J4-DU900B(-RJ) drive unit.

10. The continuous running duty and the speed are not guaranteed when the power supply voltage is dropped.

Refer to "Annotations for Rotary Servo Motor Specifications" on p. 2-41 in this catalog for the asterisks 1 to 6.

**HG-JR 3000 r/min Series (200 V Class) Electromagnetic Brake Specifications (Note 1)**

Model	HG-JR	53B	73B	103B	153B	203B	353B	503B	703B	903B
Type	Spring actuated type safety brake									
Rated voltage	24 V DC <sub>-10%</sub>									
Power consumption [W] at 20 °C		11.7	11.7	11.7	11.7	11.7	23	23	34	34
Electromagnetic brake static friction torque [N·m]		6.6 or higher	6.6 or higher	6.6 or higher	6.6 or higher	6.6 or higher	16 or higher	16 or higher	44 or higher	44 or higher
Permissible braking work	Per braking [J]	64	64	64	64	64	400	400	4500	4500
	Per hour [J]	640	640	640	640	640	4000	4000	45000	45000
Electromagnetic brake life (Note 2)	Number of braking times	5000	5000	5000	5000	5000	5000	5000	20000	20000
	Work per braking [J]	64	64	64	64	64	400	400	1000	1000

Notes: 1. The electromagnetic brake is for holding. It cannot be used for deceleration applications.  
 2. Brake gap is not adjustable. Electromagnetic brake life is defined as the time period until readjustment is needed.

**HG-JR 3000 r/min Series (200 V Class) Torque Characteristics**

**HG-JR53(B)** (Note 1, 2, 3, 5, 6, 7)

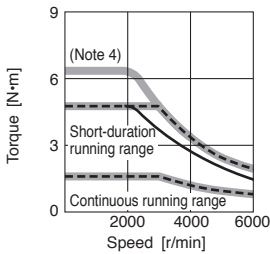

**HG-JR73(B)** (Note 1, 2, 3, 5, 6, 7)

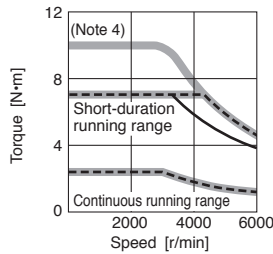

**HG-JR103(B)** (Note 1, 3, 5, 6, 7)

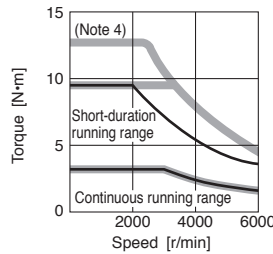

**HG-JR153(B)** (Note 1, 3, 5, 6, 7)

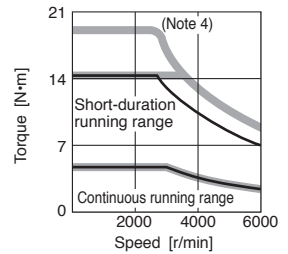

**HG-JR203(B)** (Note 1, 3, 5, 6, 7)

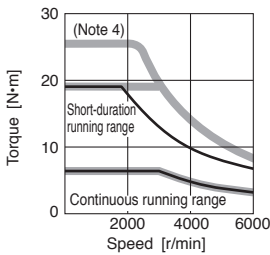

**HG-JR353(B)** (Note 1, 5)

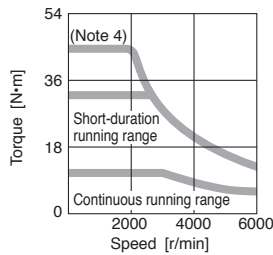

**HG-JR503(B)** (Note 1, 5)

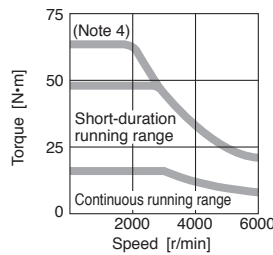

**HG-JR703(B)** (Note 1, 5)

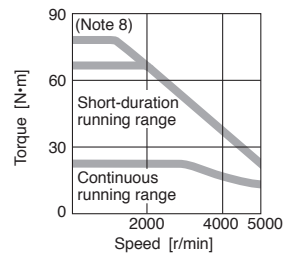

**HG-JR903(B)** (Note 1, 5)

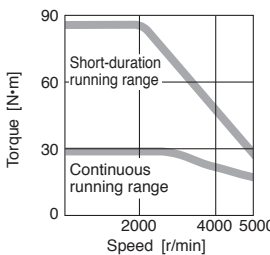

- Notes: 1. ——— : For 3-phase 200 V AC.  
 2. - - - : For 1-phase 230 V AC.  
 3. ——— : For 1-phase 200 V AC. This line is only drawn where it differs from the other two lines.  
 4. This value is applicable when the maximum torque is increased with a combination with a larger-capacity servo amplifier. Refer to "Combinations of HG-JR Servo Motor Series and Servo Amplifier (200 V/400 V Class) for Increasing the Maximum Torque to 400% of the Rated Torque" on p. 2-7 in this catalog.  
 5. Torque drops when the power supply voltage is below the specified value.  
 6. When a 1-phase 200 V AC input is used, increasing the maximum torque to 400% is not possible with HG-JR servo motor series.  
 7. When using a combination of the servo motors and MR-J4-100\_ or MR-J4-200\_ with a 1-phase power supply, use the servo amplifiers at 75 % or less of the effective load ratio.  
 8. This value is applicable when the servo motor is combined with MR-J4-DU900B(-RJ) drive unit, and the maximum torque is increased with a parameter setting.

**HG-JR 3000 r/min Series (200 V Class) Special Shaft End Specifications**

Motors with the following specifications are also available.

Key shaft (without key) (Note 1, 2)

Model	Variable dimensions								
	S	R	Q	W	QK	QL	U	r	Y
HG-JR53(B)K, 73(B)K, 103(B)K, 153(B)K, 203(B)K	16h6	40	30	5 <sup>0</sup> <sub>-0.030</sub>	25	2	3 <sup>+0.1</sup> <sub>0</sub>	2.5	M4 screw Depth: 15
HG-JR353(B)K, 503(B)K	28h6	55	50	8 <sup>0</sup> <sub>-0.036</sub>	36	5	4 <sup>+0.2</sup> <sub>0</sub>	4	M8 screw Depth: 20
HG-JR703(B)K, 903(B)K	35 <sup>+0.010</sup> <sub>0</sub>	79	75	10 <sup>0</sup> <sub>-0.036</sub>	55	5	5 <sup>+0.2</sup> <sub>0</sub>	5	

- Notes: 1. Do not use servo motors with key shafts for frequent start/stop applications as this may cause damage to the shaft.  
 2. A key is not supplied with the servo motor. The key shall be installed by the user.

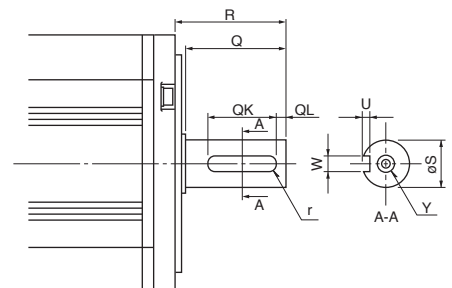

[Unit: mm]

# Rotary Servo Motors

## HG-JR 3000 r/min Series (Low Inertia, Medium Capacity) (400 V Class) Specifications

Rotary servo motor model		HG-JR	534(B)	734(B)	1034(B)	1534(B)	2034(B)	3534(B)	5034(B)	7034(B)	9034(B)	
Compatible servo amplifier model		MR-J4-	Refer to "Combinations of Rotary Servo Motor and Servo Amplifier" on p. 2-6 in this catalog.									
Power supply capacity <sup>*1</sup>		[kVA]	1.0	1.3	1.7	2.5	3.5	5.5	7.5	10	13	
Continuous running duty (Note 10)	Rated output	[kW]	0.5	0.75	1.0	1.5	2.0	3.3 <3.5> (Note 4)	5.0	7.0	9.0	
	Rated torque (Note 3)	[N·m]	1.6	2.4	3.2	4.8	6.4	10.5 <11.1> (Note 4)	15.9	22.3	28.6	
Maximum torque		[N·m]	4.8 <6.4> (Note 5)	7.2 <9.6> (Note 5)	9.6 <12.7> (Note 5)	14.3 <19.1> (Note 5)	19.1 <25.5> (Note 5)	32.0 <44.6> (Note 5)	47.7 <63.7> (Note 5)	66.8 <78.0> (Note 8)	85.8	
Rated speed (Note 10)		[r/min]	3000									
Maximum speed (Note 10)		[r/min]	6000						5000			
Permissible instantaneous speed		[r/min]	6900						5750			
Power rate at continuous rated torque	Standard	[kW/s]	16.7	27.3	38.2	60.2	82.4	83.5	133	115	147	
	With electromagnetic brake	[kW/s]	12.5	22.0	32.2	53.1	74.8	71.6	119	93.9	125	
Rated current		[A]	1.5	2.8	2.8	5.4	5.4	8.3 <8.8> (Note 4)	14	17	21	
Maximum current		[A]	4.5 <6.0> (Note 5)	8.4 <12> (Note 5)	8.4 <12> (Note 5)	17 <22> (Note 5)	17 <22> (Note 5)	26 <36> (Note 5)	41 <54> (Note 5)	52 <69> (Note 8)	67	
Regenerative braking frequency <sup>*2</sup>	MR-J4-	[times/min]	99 <100> (Note 5)	72 <489> (Note 5)	56 <382> (Note 5)	265 <275> (Note 5)	203 <209> (Note 5)	75 <98> (Note 5)	68 <89> (Note 5, 9)	56 (Note 9)	205 (Note 6, 9)	
	Standard	[× 10 <sup>-4</sup> kg·m <sup>2</sup> ]	1.52	2.09	2.65	3.79	4.92	13.2	19.0	43.3	55.8	
Moment of inertia J	With electromagnetic brake	[× 10 <sup>-4</sup> kg·m <sup>2</sup> ]	2.02	2.59	3.15	4.29	5.42	15.4	21.2	52.9	65.4	
	Recommended load to motor inertia ratio (Note 1)		10 times or less									
Speed/position detector		Absolute/incremental 22-bit encoder (resolution: 4194304 pulses/rev)										
Type		Permanent magnet synchronous motor										
Oil seal		Installed										
Thermistor		None										
Insulation class		155 (F)										
Structure		Totally enclosed, natural cooling (IP rating: IP67) (Note 2)										
Environment <sup>*3</sup>	Ambient temperature	Operation: 0 °C to 40 °C (non-freezing), storage: -15 °C to 70 °C (non-freezing)										
	Ambient humidity	Operation: 10 %RH to 80 %RH (non-condensing), storage: 10 %RH to 90 %RH (non-condensing)										
	Ambience	Indoors (no direct sunlight); no corrosive gas, inflammable gas, oil mist or dust										
	Altitude	2000 m or less above sea level (Note 7)										
Vibration resistance <sup>*4</sup>		X: 24.5 m/s <sup>2</sup> Y: 24.5 m/s <sup>2</sup>								X: 24.5 m/s <sup>2</sup> Y: 29.4 m/s <sup>2</sup>		
Vibration rank		V10 <sup>*6</sup>										
Permissible load for the shaft <sup>*5</sup>	L	[mm]	40	40	40	40	40	55	55	79	79	
	Radial	[N]	323	323	323	323	323	980	980	2450	2450	
	Thrust	[N]	284	284	284	284	284	490	490	980	980	
Mass	Standard	[kg]	3.0	3.7	4.5	5.9	7.5	13	18	29	36	
	With electromagnetic brake	[kg]	4.4	5.1	5.9	7.3	8.9	15	20	35	42	

Notes: 1. Contact your local sales office if the load to motor inertia ratio exceeds the value in the table.

2. The shaft-through portion is excluded. Refer to the asterisk 7 of "Annotations for Rotary Servo Motor Specifications" on p. 2-41 in this catalog for the shaft-through portion.

3. When unbalanced torque is generated, such as in a vertical lift machine, keep the unbalanced torque of the machine under 70% of the servo motor rated torque.

4. The value in angle brackets is applicable when the servo motor is combined with MR-J4-500GF4(-RJ)/MR-J4-500B4(-RJ)/MR-J4-500A4(-RJ) servo amplifier.

5. The value in angle brackets is applicable when the maximum torque is increased with a combination with a larger-capacity servo amplifier. Refer to "Combinations of HG-JR Servo Motor Series and Servo Amplifier (200 V/400 V Class) for Increasing the Maximum Torque to 400% of the Rated Torque" on p. 2-7 in this catalog for the available combinations.

6. This value is applicable when the external regenerative resistors, GRZG400-Ω (standard accessory) are used with cooling fans (two units of 92 mm × 92 mm, minimum airflow: 1.0 m<sup>3</sup>/min). Note that [Pr. PA02] must be changed.

7. Refer to "Servo Motor Instruction Manual (Vol. 3)" for the restrictions when using the servo motors at altitude exceeding 1000 m and up to 2000 m above sea level.

8. The value in angle brackets is applicable when the servo motor is combined with MR-J4-DU900B4(-RJ) drive unit, and the maximum torque is increased with a parameter setting.

9. This value is applicable when the servo motor is combined with MR-J4-\_GF4(-RJ)/MR-J4-\_B4(-RJ)/MR-J4-\_A4(-RJ) servo amplifier. Contact your local sales office for the regenerative braking frequency with MR-J4-DU900B4(-RJ) drive unit.

10. The continuous running duty and the speed are not guaranteed when the power supply voltage is dropped.

Refer to "Annotations for Rotary Servo Motor Specifications" on p. 2-41 in this catalog for the asterisks 1 to 6.

**HG-JR 3000 r/min Series (400 V Class) Electromagnetic Brake Specifications (Note 1)**

Model	HG-JR	534B	734B	1034B	1534B	2034B	3534B	5034B	7034B	9034B
Type	Spring actuated type safety brake									
Rated voltage	24 V DC <sub>-10%</sub>									
Power consumption [W] at 20 °C		11.7	11.7	11.7	11.7	11.7	23	23	34	34
Electromagnetic brake static friction torque [N·m]		6.6 or higher	6.6 or higher	6.6 or higher	6.6 or higher	6.6 or higher	16 or higher	16 or higher	44 or higher	44 or higher
Permissible braking work	Per braking [J]	64	64	64	64	64	400	400	4500	4500
	Per hour [J]	640	640	640	640	640	4000	4000	45000	45000
Electromagnetic brake life (Note 2)	Number of braking times	5000	5000	5000	5000	5000	5000	5000	20000	20000
	Work per braking [J]	64	64	64	64	64	400	400	1000	1000

Notes: 1. The electromagnetic brake is for holding. It cannot be used for deceleration applications.  
 2. Brake gap is not adjustable. Electromagnetic brake life is defined as the time period until readjustment is needed.

**HG-JR 3000 r/min Series (400 V Class) Torque Characteristics**

**HG-JR534(B)** (Note 1, 2, 4)

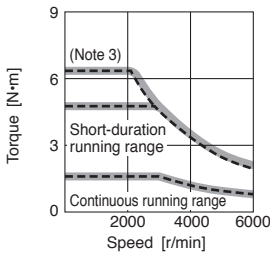

**HG-JR734(B)** (Note 1, 2, 4)

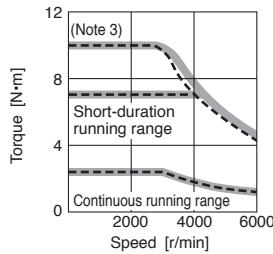

**HG-JR1034(B)** (Note 1, 2, 4)

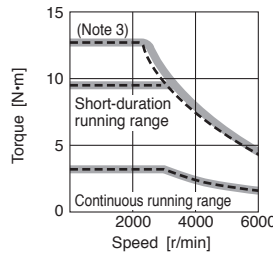

**HG-JR1534(B)** (Note 1, 2, 4)

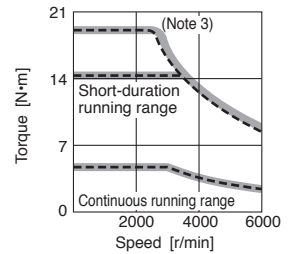

**HG-JR2034(B)** (Note 1, 2, 4)

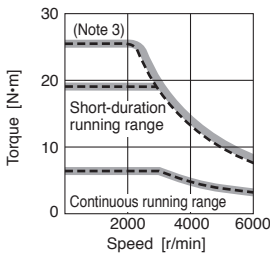

**HG-JR3534(B)** (Note 1, 2, 4)

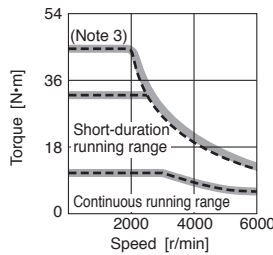

**HG-JR5034(B)** (Note 1, 2, 4)

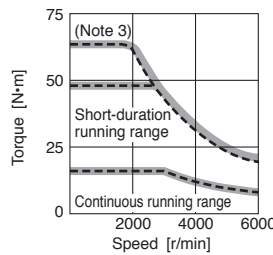

**HG-JR7034(B)** (Note 1, 2, 4)

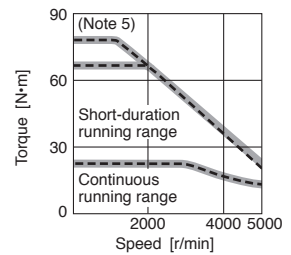

**HG-JR9034(B)** (Note 1, 2, 4)

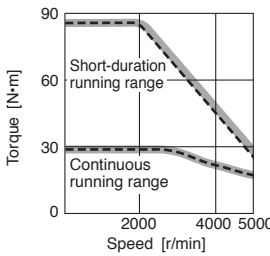

Notes: 1. — : For 3-phase 400 V AC.  
 2. - - - : For 3-phase 380 V AC.  
 3. This value is applicable when the maximum torque is increased with a combination with a larger-capacity servo amplifier. Refer to "Combinations of HG-JR Servo Motor Series and Servo Amplifier (200 V/400 V Class) for Increasing the Maximum Torque to 400% of the Rated Torque" on p. 2-7 in this catalog.  
 4. Torque drops when the power supply voltage is below the specified value.  
 5. This value is applicable when the servo motor is combined with MR-J4-DU900B4(-RJ) drive unit, and the maximum torque is increased with a parameter setting.

**HG-JR 3000 r/min Series (400 V Class) Special Shaft End Specifications**

Motors with the following specifications are also available.

Key shaft (without key) (Note 1, 2)

Model	Variable dimensions								
	S	R	Q	W	QK	QL	U	r	Y
HG-JR534(B)K, 734(B)K, 1034(B)K, 1534(B)K, 2034(B)K	16h6	40	30	5 <sub>-0.030</sub> <sup>0</sup>	25	2	3 <sub>0</sub> <sup>+0.1</sup>	2.5	M4 screw Depth: 15
HG-JR3534(B)K, 5034(B)K	28h6	55	50	8 <sub>-0.036</sub> <sup>0</sup>	36	5	4 <sub>0</sub> <sup>+0.2</sup>	4	M8 screw Depth: 20
HG-JR7034(B)K, 9034(B)K	35 <sub>0</sub> <sup>+0.010</sup>	79	75	10 <sub>-0.036</sub> <sup>0</sup>	55	5	5 <sub>0</sub> <sup>+0.2</sup>	5	

Notes: 1. Do not use servo motors with key shafts for frequent start/stop applications as this may cause damage to the shaft.  
 2. A key is not supplied with the servo motor. The key shall be installed by the user.

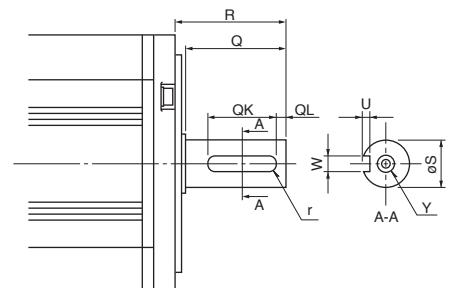

[Unit: mm]

# Rotary Servo Motors

## HG-JR 1000 r/min Series (Low Inertia, Medium/Large Capacity) (200 V Class) Specifications

Rotary servo motor model		HG-JR	601(B)	801(B)	12K1(B)	15K1	20K1	25K1	30K1	37K1					
Compatible servo amplifier model		MR-J4-	Refer to "Combinations of Rotary Servo Motor and Servo Amplifier" on p. 2-5 in this catalog.												
Power supply capacity <sup>1</sup>		[kVA]	8.6	12	18	22	30	38	48	59					
Continuous running duty (Note 7)	Rated output	[kW]	6.0	8.0	12	15	20	25	30	37					
	Rated torque (Note 3)	[N·m]	57.3	76.4	115	143	191	239	286	353					
Maximum torque		[N·m]	172	229	345	429	573	717	858	1059					
Rated speed (Note 7)		[r/min]	1000												
Maximum speed (Note 7)		[r/min]	2000				1500								
Permissible instantaneous speed		[r/min]	2300				1725								
Power rate at continuous rated torque	Standard	[kW/s]	187	265	420	418	582	748	594	761					
	With electromagnetic brake	[kW/s]	167	243	394	-	-	-	-	-					
Rated current		[A]	31	47	60	67	94	95	121	152					
Maximum current		[A]	108	165	208	231	318	313	399	495					
Regenerative braking frequency <sup>2</sup>	MR-J4-	[times/min]	82 (Note 6)	322 (Note 4, 6)	224 (Note 4, 6)	234 (Note 4, 6)	183 (Note 4, 6)	150 (Note 4, 6)	- (Note 6)	- (Note 6)					
Moment of inertia J	Standard	[× 10 <sup>-4</sup> kg·m <sup>2</sup> ]	176	220	315	489	627	764	1377	1637					
	With electromagnetic brake	[× 10 <sup>-4</sup> kg·m <sup>2</sup> ]	196	240	336	-	-	-	-	-					
Recommended load to motor inertia ratio (Note 1)			10 times or less												
Speed/position detector			Absolute/incremental 22-bit encoder (resolution: 4194304 pulses/rev)												
Type			Permanent magnet synchronous motor												
Oil seal			Installed												
Thermistor			None				Built-in								
Insulation class			155 (F)												
Structure			Totally enclosed, natural cooling (IP rating: IP67) (Note 2)				Totally enclosed, force cooling (IP rating: IP44) (Note 2)								
Environment <sup>3</sup>	Ambient temperature		Operation: 0 °C to 40 °C (non-freezing), storage: -15 °C to 70 °C (non-freezing)												
	Ambient humidity		Operation: 10 %RH to 80 %RH (non-condensing), storage: 10 %RH to 90 %RH (non-condensing)												
	Ambience		Indoors (no direct sunlight); no corrosive gas, inflammable gas, oil mist or dust												
	Altitude		2000 m or less above sea level (Note 5)												
Vibration resistance <sup>4</sup>			X: 24.5 m/s <sup>2</sup> Y: 24.5 m/s <sup>2</sup>							X: 9.8 m/s <sup>2</sup> Y: 9.8 m/s <sup>2</sup>					
Vibration rank			V10 <sup>6</sup>												
Permissible load for the shaft <sup>5</sup>	L	[mm]	85	116	116	140	140	140	140	140					
	Radial	[N]	2450	2940	2940	3234	3234	3234	4900	4900					
	Thrust	[N]	980	980	980	1470	1470	1470	1960	1960					
Mass	Standard	[kg]	53	62	86	120	145	165	215	240					
	With electromagnetic brake	[kg]	65	74	97	-	-	-	-	-					
Cooling fan	Power supply voltage		-	-	-	3-phase 200 V AC to 240 V AC									
	Frequency	[Hz]	-	-	-	50	60	50	60	50	60	50	60		
	Input	[W]	-	-	-	65	85	65	85	65	85	130	225	130	225
	Current	[A]	-	-	-	0.20	0.23	0.20	0.23	0.20	0.23	0.47	0.60	0.47	0.60

Notes: 1. Contact your local sales office if the load to motor inertia ratio exceeds the value in the table.

2. The shaft-through portion is excluded. Refer to the asterisk 7 of "Annotations for Rotary Servo Motor Specifications" on p. 2-41 in this catalog for the shaft-through portion.

3. When unbalanced torque is generated, such as in a vertical lift machine, keep the unbalanced torque of the machine under 70% of the servo motor rated torque.

4. This value is applicable when the external regenerative resistors, GRZG400-Ω (standard accessory) are used with cooling fans (two units of 92 mm × 92 mm, minimum airflow: 1.0 m<sup>3</sup>/min). Note that [Pr. PA02] must be changed.

5. Refer to "Servo Motor Instruction Manual (Vol. 3)" for the restrictions when using the servo motors at altitude exceeding 1000 m and up to 2000 m above sea level.

6. This value is applicable when the servo motor is combined with MR-J4-GF(-RJ)/MR-J4-B(-RJ)/MR-J4-A(-RJ) servo amplifier. Contact your local sales office for the regenerative braking frequency with MR-J4-DUB(-RJ)/MR-J4-DUA(-RJ) drive unit.

7. The continuous running duty and the speed are not guaranteed when the power supply voltage is dropped.

Refer to "Annotations for Rotary Servo Motor Specifications" on p. 2-41 in this catalog for the asterisks 1 to 6.

**HG-JR 1000 r/min Series (200 V Class) Electromagnetic Brake Specifications (Note 1)**

Model	HG-JR	601B	801B	12K1B
Type	Spring actuated type safety brake			
Rated voltage	24 V DC <sub>-10%</sub>			
Power consumption [W] at 20 °C	32		32	32
Electromagnetic brake static friction torque [N·m]	126 or higher		126 or higher	126 or higher
Permissible braking work	Per braking [J]	5000	5000	5000
	Per hour [J]	45200	45200	45200
Electromagnetic brake life (Note 2)	Number of braking times	20000	20000	20000
	Work per braking [J]	400	400	400

Notes: 1. The electromagnetic brake is for holding. It cannot be used for deceleration applications.  
 2. Brake gap is not adjustable. Electromagnetic brake life is defined as the time period until readjustment is needed.

**HG-JR 1000 r/min Series (200 V Class) Torque Characteristics**

**HG-JR601(B)** (Note 1, 2)

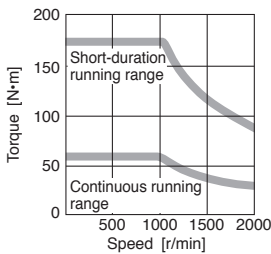

**HG-JR801(B)** (Note 1, 2)

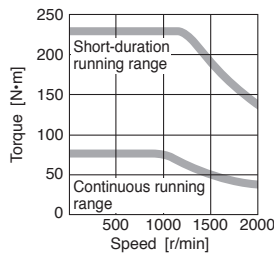

**HG-JR12K1(B)** (Note 1, 2)

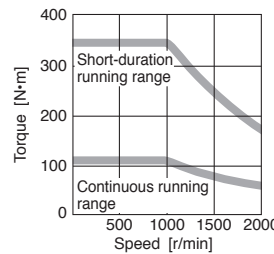

**HG-JR15K1** (Note 1, 2)

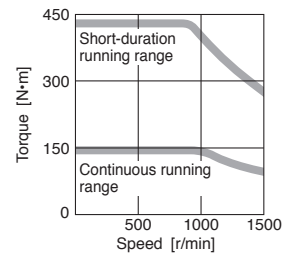

**HG-JR20K1** (Note 1, 2)

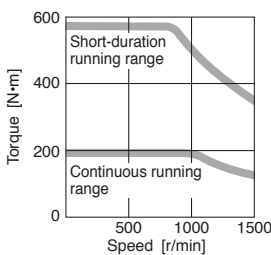

**HG-JR25K1** (Note 1, 2)

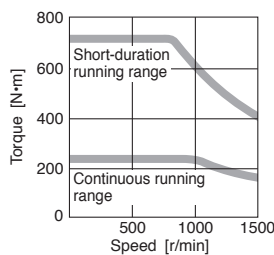

**HG-JR30K1** (Note 1, 2)

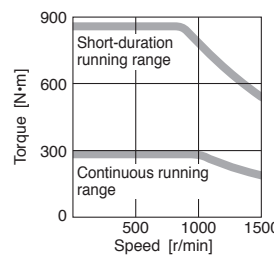

**HG-JR37K1** (Note 1, 2)

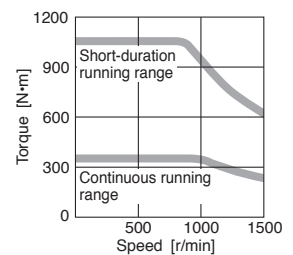

Notes: 1. — : For 3-phase 200 V AC.  
 2. Torque drops when the power supply voltage is below the specified value.

**HG-JR 1000 r/min Series (200 V Class) Special Shaft End Specifications**

Motors with the following specifications are also available.

Key shaft (without key) (Note 1, 2)

Model	Variable dimensions									Fig.
	S	R	Q	W	QK	QL	U	r	Y	
HG-JR601(B)K	42h6	85	79	12 <sup>0</sup> <sub>-0.040</sub>	70	5	5 <sup>+0.2</sup> <sub>0</sub>	6	M8 screw Depth: 19.8	A
HG-JR801(B)K, 12K1(B)K	55m6	116	110	16 <sup>0</sup> <sub>-0.040</sub>	90	5	6 <sup>+0.2</sup> <sub>0</sub>	8	M10 screw Depth: 27	
HG-JR15K1K, 20K1K, 25K1K	65m6	140	130	18 <sup>0</sup> <sub>-0.040</sub>	120	5	7 <sup>+0.2</sup> <sub>0</sub>	9	M12 screw Depth: 25	B
HG-JR30K1K, 37K1K	80m6	140	140	22 <sup>0</sup> <sub>-0.040</sub>	132	7	9 <sup>+0.2</sup> <sub>0</sub>	11	M16 screw Depth: 30	

Notes: 1. Do not use servo motors with key shafts for frequent start/stop applications as this may cause damage to the shaft.  
 2. A key is not supplied with the servo motor. The key shall be installed by the user.

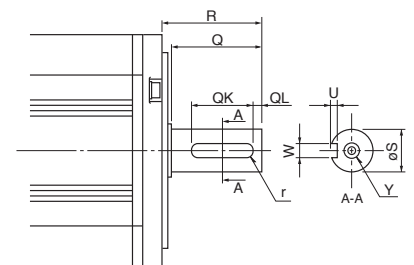

Fig. A

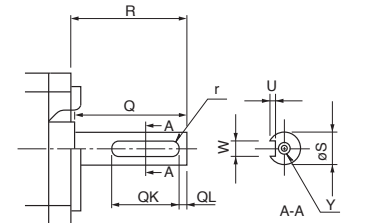

Fig. B

[Unit: mm]

# Rotary Servo Motors

## HG-JR 1000 r/min Series (Low Inertia, Medium/Large Capacity) (400 V Class) Specifications

Rotary servo motor model		HG-JR	6014(B)	8014(B)	12K14(B)	15K14	20K14	25K14	30K14	37K14			
Compatible servo amplifier model		MR-J4-	Refer to "Combinations of Rotary Servo Motor and Servo Amplifier" on p. 2-6 in this catalog.										
Power supply capacity <sup>1</sup>		[kVA]	8.6	12	18	22	30	38	48	59			
Continuous running duty (Note 7)	Rated output	[kW]	6.0	8.0	12	15	20	25	30	37			
	Rated torque (Note 3)	[N·m]	57.3	76.4	115	143	191	239	286	353			
Maximum torque		[N·m]	172	229	345	429	573	717	858	1059			
Rated speed (Note 7)		[r/min]	1000										
Maximum speed (Note 7)		[r/min]	2000				1500						
Permissible instantaneous speed		[r/min]	2300				1725						
Power rate at continuous rated torque	Standard	[kW/s]	187	265	420	418	582	748	594	761			
	With electromagnetic brake	[kW/s]	167	243	394	-	-	-	-	-			
Rated current		[A]	16	23	30	33	47	48	60	76			
Maximum current		[A]	54	80	104	114	161	160	202	248			
Regenerative braking frequency <sup>2</sup>	MR-J4-	[times/min]	83 (Note 6)	331 (Note 4, 6)	229 (Note 4, 6)	239 (Note 4, 6)	187 (Note 4, 6)	152 (Note 4, 6)	- (Note 6)	- (Note 6)			
Moment of inertia J	Standard	[× 10 <sup>-4</sup> kg·m <sup>2</sup> ]	176	220	315	489	627	764	1377	1637			
	With electromagnetic brake	[× 10 <sup>-4</sup> kg·m <sup>2</sup> ]	196	240	336	-	-	-	-	-			
Recommended load to motor inertia ratio (Note 1)			10 times or less										
Speed/position detector			Absolute/incremental 22-bit encoder (resolution: 4194304 pulses/rev)										
Type			Permanent magnet synchronous motor										
Oil seal			Installed										
Thermistor			None				Built-in						
Insulation class			155 (F)										
Structure			Totally enclosed, natural cooling (IP rating: IP67) (Note 2)				Totally enclosed, force cooling (IP rating: IP44) (Note 2)						
Environment <sup>3</sup>	Ambient temperature		Operation: 0 °C to 40 °C (non-freezing), storage: -15 °C to 70 °C (non-freezing)										
	Ambient humidity		Operation: 10 %RH to 80 %RH (non-condensing), storage: 10 %RH to 90 %RH (non-condensing)										
	Ambience		Indoors (no direct sunlight); no corrosive gas, inflammable gas, oil mist or dust										
	Altitude		2000 m or less above sea level (Note 5)										
Vibration resistance <sup>4</sup>			X: 24.5 m/s <sup>2</sup> Y: 24.5 m/s <sup>2</sup>						X: 9.8 m/s <sup>2</sup> Y: 9.8 m/s <sup>2</sup>				
Vibration rank			V10 <sup>6</sup>										
Permissible load for the shaft <sup>5</sup>	L	[mm]	85	116	116	140	140	140	140	140			
	Radial	[N]	2450	2940	2940	3234	3234	3234	4900	4900			
	Thrust	[N]	980	980	980	1470	1470	1470	1960	1960			
Mass	Standard	[kg]	53	62	86	120	145	165	215	240			
	With electromagnetic brake	[kg]	65	74	97	-	-	-	-	-			
Cooling fan	Power supply voltage		-	-	-	3-phase 380 V AC to 480 V AC				3-phase 380 V AC to 460 V AC			
	Frequency	[Hz]	-	-	-	50	60	50	60	50	60	50	60
	Input	[W]	-	-	-	65	90	65	90	65	90	130	230
	Current	[A]	-	-	-	0.12	0.14	0.12	0.14	0.12	0.14	0.25	0.33

Notes: 1. Contact your local sales office if the load to motor inertia ratio exceeds the value in the table.

2. The shaft-through portion is excluded. Refer to the asterisk 7 of "Annotations for Rotary Servo Motor Specifications" on p. 2-41 in this catalog for the shaft-through portion.

3. When unbalanced torque is generated, such as in a vertical lift machine, keep the unbalanced torque of the machine under 70% of the servo motor rated torque.

4. This value is applicable when the external regenerative resistors, GRZG400-Ω (standard accessory) are used with cooling fans (two units of 92 mm × 92 mm, minimum airflow: 1.0 m<sup>3</sup>/min). Note that [Pr. PA02] must be changed.

5. Refer to "Servo Motor Instruction Manual (Vol. 3)" for the restrictions when using the servo motors at altitude exceeding 1000 m and up to 2000 m above sea level.

6. This value is applicable when the servo motor is combined with MR-J4-GF4(-RJ)/MR-J4-B4(-RJ)/MR-J4-A4(-RJ) servo amplifier. Contact your local sales office for the regenerative braking frequency with MR-J4-DU\_B4(-RJ)/MR-J4-DU\_A4(-RJ) drive unit.

7. The continuous running duty and the speed are not guaranteed when the power supply voltage is dropped.

Refer to "Annotations for Rotary Servo Motor Specifications" on p. 2-41 in this catalog for the asterisks 1 to 6.



**HG-JR 1000 r/min Series (400 V Class) Electromagnetic Brake Specifications (Note 1)**

Model		HG-JR	6014B	8014B	12K14B
Type		Spring actuated type safety brake			
Rated voltage		24 V DC <sub>-10%</sub>			
Power consumption [W] at 20 °C		32	32	32	32
Electromagnetic brake static friction torque [N·m]		126 or higher	126 or higher	126 or higher	126 or higher
Permissible braking work	Per braking [J]	5000	5000	5000	5000
	Per hour [J]	45200	45200	45200	45200
Electromagnetic brake life (Note 2)	Number of braking times	20000	20000	20000	20000
	Work per braking [J]	400	400	400	400

Notes: 1. The electromagnetic brake is for holding. It cannot be used for deceleration applications.  
 2. Brake gap is not adjustable. Electromagnetic brake life is defined as the time period until readjustment is needed.

**HG-JR 1000 r/min Series (400 V Class) Torque Characteristics**

**HG-JR6014(B)** (Note 1, 2, 3)

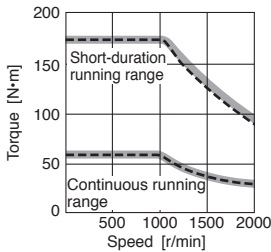

**HG-JR8014(B)** (Note 1, 2, 3)

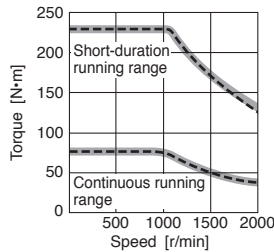

**HG-JR12K14(B)** (Note 1, 2, 3)

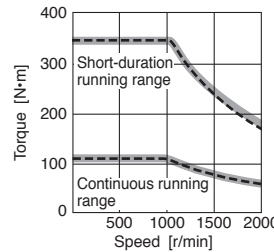

**HG-JR15K14** (Note 1, 2, 3)

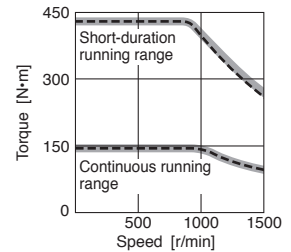

**HG-JR20K14** (Note 1, 2, 3)

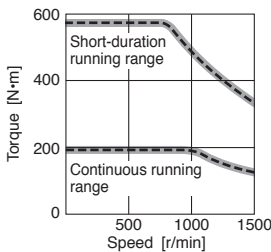

**HG-JR25K14** (Note 1, 2, 3)

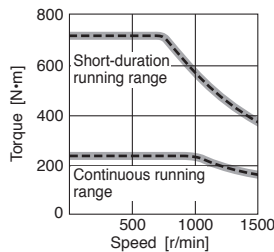

**HG-JR30K14** (Note 1, 2, 3)

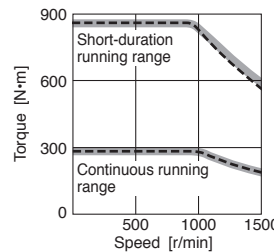

**HG-JR37K14** (Note 1, 2, 3)

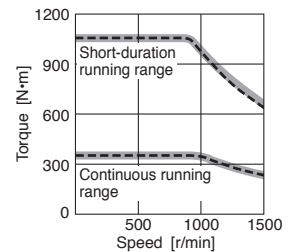

Notes: 1. — : For 3-phase 400 V AC.  
 2. - - - : For 3-phase 380 V AC.  
 3. Torque drops when the power supply voltage is below the specified value.

**HG-JR 1000 r/min Series (400 V Class) Special Shaft End Specifications**

Motors with the following specifications are also available.

Key shaft (without key) (Note 1, 2)

Model	Variable dimensions								Fig.	
	S	R	Q	W	QK	QL	U	r		
HG-JR6014(B)K	42h6	85	79	12 <sup>0</sup> <sub>-0.040</sub>	70	5	5 <sup>+0.2</sup> <sub>0</sub>	6	M8 screw Depth: 19.8	A
HG-JR8014(B)K, 12K14(B)K	55m6	116	110	16 <sup>0</sup> <sub>-0.040</sub>	90	5	6 <sup>+0.2</sup> <sub>0</sub>	8	M10 screw Depth: 27	
HG-JR15K14K, 20K14K, 25K14K	65m6	140	130	18 <sup>0</sup> <sub>-0.040</sub>	120	5	7 <sup>+0.2</sup> <sub>0</sub>	9	M12 screw Depth: 25	
HG-JR30K14K, 37K14K	80m6	140	140	22 <sup>0</sup> <sub>-0.040</sub>	132	7	9 <sup>+0.2</sup> <sub>0</sub>	11	M16 screw Depth: 30	

Notes: 1. Do not use servo motors with key shafts for frequent start/stop applications as this may cause damage to the shaft.  
 2. A key is not supplied with the servo motor. The key shall be installed by the user.

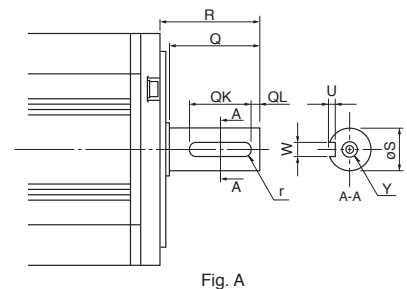

Fig. A

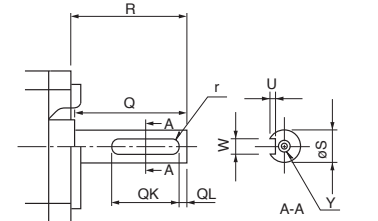

Fig. B

[Unit: mm]

# Rotary Servo Motors

## HG-JR 1500 r/min Series (Low Inertia, Medium/Large Capacity) (200 V Class) Specifications

Rotary servo motor model		HG-JR	701M(B)	11K1M(B)	15K1M(B)	22K1M	30K1M	37K1M			
Compatible servo amplifier model		MR-J4-	Refer to "Combinations of Rotary Servo Motor and Servo Amplifier" on p. 2-5 in this catalog.								
Power supply capacity <sup>*1</sup>		[kVA]	10	16	22	33	48	59			
Continuous running duty (Note 8)	Rated output	[kW]	7.0	11	15	22	30	37			
	Rated torque (Note 3)	[N·m]	44.6	70.0	95.5	140	191	236			
Maximum torque		[N·m]	134 <156> (Note 6)	210	286	420	573	707			
Rated speed (Note 8)		[r/min]	1500								
Maximum speed (Note 8)		[r/min]	3000			2500					
Permissible instantaneous speed		[r/min]	3450			2875					
Power rate at continuous rated torque	Standard	[kW/s]	113	223	289	401	582	726			
	With electromagnetic brake	[kW/s]	101	204	271	-	-	-			
Rated current		[A]	34	61	76	99	139	151			
Maximum current		[A]	111 <130> (Note 6)	200	246	315	479	561			
Regenerative braking frequency <sup>*2</sup>	MR-J4-	[times/min]	36 (Note 7)	143 (Note 4, 7)	162 (Note 4, 7)	104 (Note 4, 7)	- (Note 7)	- (Note 7)			
Moment of inertia J	Standard	[× 10 <sup>-4</sup> kg·m <sup>2</sup> ]	176	220	315	489	627	764			
	With electromagnetic brake	[× 10 <sup>-4</sup> kg·m <sup>2</sup> ]	196	240	336	-	-	-			
Recommended load to motor inertia ratio (Note 1)			10 times or less								
Speed/position detector			Absolute/incremental 22-bit encoder (resolution: 4194304 pulses/rev)								
Type			Permanent magnet synchronous motor								
Oil seal			Installed								
Thermistor			None			Built-in					
Insulation class			155 (F)								
Structure			Totally enclosed, natural cooling (IP rating: IP67) (Note 2)			Totally enclosed, force cooling (IP rating: IP44) (Note 2)					
Environment <sup>*3</sup>	Ambient temperature		Operation: 0 °C to 40 °C (non-freezing), storage: -15 °C to 70 °C (non-freezing)								
	Ambient humidity		Operation: 10 %RH to 80 %RH (non-condensing), storage: 10 %RH to 90 %RH (non-condensing)								
	Ambience		Indoors (no direct sunlight); no corrosive gas, inflammable gas, oil mist or dust								
	Altitude		2000 m or less above sea level (Note 5)								
Vibration resistance <sup>*4</sup>			X: 24.5 m/s <sup>2</sup> Y: 24.5 m/s <sup>2</sup>								
Vibration rank			V10 <sup>*6</sup>								
Permissible load for the shaft <sup>*5</sup>	L	[mm]	85	116	116	140	140	140			
	Radial	[N]	2450	2940	2940	3234	3234	3234			
	Thrust	[N]	980	980	980	1470	1470	1470			
Mass	Standard	[kg]	53	62	86	120	145	165			
	With electromagnetic brake	[kg]	65	74	97	-	-	-			
Cooling fan	Power supply voltage		-	-	-	3-phase 200 V AC to 240 V AC					
	Frequency	[Hz]	-	-	-	50	60	50	60	50	60
	Input	[W]	-	-	-	65	85	65	85	65	85
	Current	[A]	-	-	-	0.20	0.23	0.20	0.23	0.20	0.23

Notes: 1. Contact your local sales office if the load to motor inertia ratio exceeds the value in the table.

2. The shaft-through portion is excluded. Refer to the asterisk 7 of "Annotations for Rotary Servo Motor Specifications" on p. 2-41 in this catalog for the shaft-through portion.

3. When unbalanced torque is generated, such as in a vertical lift machine, keep the unbalanced torque of the machine under 70% of the servo motor rated torque.

4. This value is applicable when the external regenerative resistors, GRZG400-Ω (standard accessory) are used with cooling fans (two units of 92 mm × 92 mm, minimum airflow: 1.0 m<sup>3</sup>/min). Note that [Pr. PA02] must be changed.

5. Refer to "Servo Motor Instruction Manual (Vol. 3)" for the restrictions when using the servo motors at altitude exceeding 1000 m and up to 2000 m above sea level.

6. The value in angle brackets is applicable when the servo motor is combined with MR-J4-DU900B(-RJ) drive unit, and the maximum torque is increased with a parameter setting.

7. This value is applicable when the servo motor is combined with MR-J4-\_GF(-RJ)/MR-J4-\_B(-RJ)/MR-J4-\_A(-RJ) servo amplifier. Contact your local sales office for the regenerative braking frequency with MR-J4-DU\_B(-RJ)/MR-J4-DU\_A(-RJ) drive unit.

8. The continuous running duty and the speed are not guaranteed when the power supply voltage is dropped.

Refer to "Annotations for Rotary Servo Motor Specifications" on p. 2-41 in this catalog for the asterisks 1 to 6.

**HG-JR 1500 r/min Series (200 V Class) Electromagnetic Brake Specifications** (Note 1)

Model	HG-JR	701MB	11K1MB	15K1MB
Type	Spring actuated type safety brake			
Rated voltage	24 V DC <sub>-10%</sub>			
Power consumption [W] at 20 °C	32			
Electromagnetic brake static friction torque [N·m]	126 or higher			
Permissible braking work	Per braking [J]	5000	5000	5000
	Per hour [J]	45200	45200	45200
Electromagnetic brake life (Note 2)	Number of braking times	20000	20000	20000
	Work per braking [J]	400	400	400

Notes: 1. The electromagnetic brake is for holding. It cannot be used for deceleration applications.  
 2. Brake gap is not adjustable. Electromagnetic brake life is defined as the time period until readjustment is needed.

**HG-JR 1500 r/min Series (200 V Class) Torque Characteristics**

**HG-JR701M(B)** (Note 1, 2)

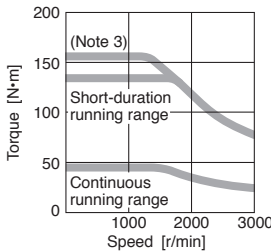

**HG-JR11K1M(B)** (Note 1, 2)

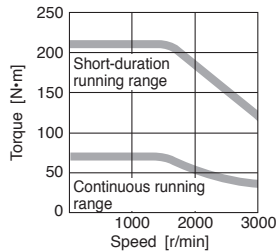

**HG-JR15K1M(B)** (Note 1, 2)

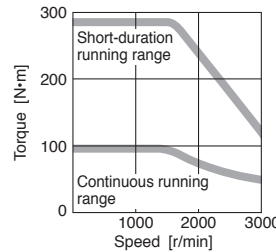

**HG-JR22K1M** (Note 1, 2)

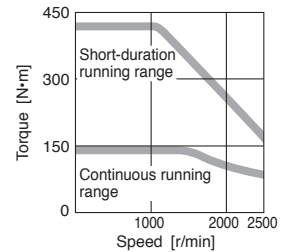

**HG-JR30K1M** (Note 1, 2)

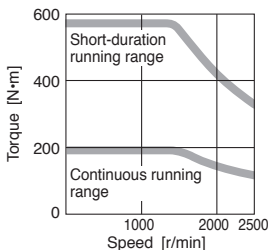

**HG-JR37K1M** (Note 1, 2)

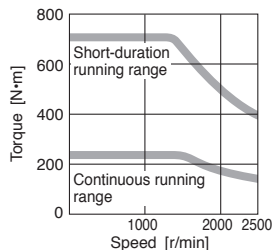

Notes: 1. — : For 3-phase 200 V AC.  
 2. Torque drops when the power supply voltage is below the specified value.  
 3. This value is applicable when the servo motor is combined with MR-J4-DU900B(-RJ) drive unit, and the maximum torque is increased with a parameter setting.

**HG-JR 1500 r/min Series (200 V Class) Special Shaft End Specifications**

Motors with the following specifications are also available.

Key shaft (without key) (Note 1, 2)

Model	Variable dimensions								
	S	R	Q	W	QK	QL	U	r	Y
HG-JR701M(B)K	42h6	85	79	12 <sup>0</sup> <sub>-0.040</sub>	70	5	5 <sup>+0.2</sup> <sub>0</sub>	6	M8 screw Depth: 19.8
HG-JR11K1M(B)K, 15K1M(B)K	55m6	116	110	16 <sup>0</sup> <sub>-0.040</sub>	90	5	6 <sup>+0.2</sup> <sub>0</sub>	8	M10 screw Depth: 27
HG-JR22K1MK, 30K1MK, 37K1MK	65m6	140	130	18 <sup>0</sup> <sub>-0.040</sub>	120	5	7 <sup>+0.2</sup> <sub>0</sub>	9	M12 screw Depth: 25

Notes: 1. Do not use servo motors with key shafts for frequent start/stop applications as this may cause damage to the shaft.  
 2. A key is not supplied with the servo motor. The key shall be installed by the user.

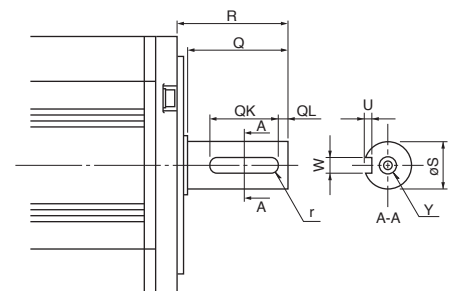

[Unit: mm]

# Rotary Servo Motors

## HG-JR 1500 r/min Series (Low Inertia, Medium/Large Capacity) (400 V Class) Specifications

Rotary servo motor model		HG-JR	701M4(B)	11K1M4(B)	15K1M4(B)	22K1M4	30K1M4	37K1M4	45K1M4	55K1M4			
Compatible servo amplifier model		MR-J4-	Refer to "Combinations of Rotary Servo Motor and Servo Amplifier" on p. 2-6 in this catalog.										
Power supply capacity <sup>*1</sup>		[kVA]	10	16	22	33	48	59	71	80			
Continuous running duty (Note 8)	Rated output	[kW]	7.0	11	15	22	30	37	45	55			
	Rated torque (Note 3)	[N·m]	44.6	70.0	95.5	140	191	236	286	350			
Maximum torque		[N·m]	134 <156> (Note 6)	210	286	420	573	707	859	1050			
Rated speed (Note 8)		[r/min]	1500										
Maximum speed (Note 8)		[r/min]	3000			2500							
Permissible instantaneous speed		[r/min]	3450			2875							
Power rate at continuous rated torque	Standard	[kW/s]	113	223	289	401	582	726	596	749			
	With electromagnetic brake	[kW/s]	101	204	271	-	-	-	-	-			
Rated current		[A]	17	31	38	50	68	79	85	110			
Maximum current		[A]	56 <65> (Note 6)	100	123	170	235	263	288	357			
Regenerative braking frequency <sup>*2</sup>	MR-J4-	[times/min]	36 (Note 7)	143 (Note 4, 7)	162 (Note 4, 7)	104 (Note 4, 7)	- (Note 7)	- (Note 7)	- (Note 7)	- (Note 7)			
Moment of inertia J	Standard	[× 10 <sup>-4</sup> kg·m <sup>2</sup> ]	176	220	315	489	627	764	1377	1637			
	With electromagnetic brake	[× 10 <sup>-4</sup> kg·m <sup>2</sup> ]	196	240	336	-	-	-	-	-			
Recommended load to motor inertia ratio (Note 1)			10 times or less										
Speed/position detector			Absolute/incremental 22-bit encoder (resolution: 4194304 pulses/rev)										
Type			Permanent magnet synchronous motor										
Oil seal			Installed										
Thermistor			None			Built-in							
Insulation class			155 (F)										
Structure			Totally enclosed, natural cooling (IP rating: IP67) (Note 2)			Totally enclosed, force cooling (IP rating: IP44) (Note 2)							
Environment <sup>*3</sup>	Ambient temperature		Operation: 0 °C to 40 °C (non-freezing), storage: -15 °C to 70 °C (non-freezing)										
	Ambient humidity		Operation: 10 %RH to 80 %RH (non-condensing), storage: 10 %RH to 90 %RH (non-condensing)										
	Ambience		Indoors (no direct sunlight); no corrosive gas, inflammable gas, oil mist or dust										
	Altitude		2000 m or less above sea level (Note 5)										
Vibration resistance <sup>*4</sup>			X: 24.5 m/s <sup>2</sup> Y: 24.5 m/s <sup>2</sup>						X: 9.8 m/s <sup>2</sup> Y: 9.8 m/s <sup>2</sup>				
Vibration rank			V10 <sup>*6</sup>										
Permissible load for the shaft <sup>*5</sup>	L	[mm]	85	116	116	140	140	140	140	140			
	Radial	[N]	2450	2940	2940	3234	3234	3234	4900	4900			
	Thrust	[N]	980	980	980	1470	1470	1470	1960	1960			
Mass	Standard	[kg]	53	62	86	120	145	165	215	240			
	With electromagnetic brake	[kg]	65	74	97	-	-	-	-	-			
Cooling fan	Power supply voltage		-	-	-	3-phase 380 V AC to 480 V AC				3-phase 380 V AC to 460 V AC			
	Frequency	[Hz]	-	-	-	50	60	50	60	50	60	50	60
	Input	[W]	-	-	-	65	90	65	90	65	90	130	230
	Current	[A]	-	-	-	0.12	0.14	0.12	0.14	0.12	0.14	0.25	0.33

- Notes: 1. Contact your local sales office if the load to motor inertia ratio exceeds the value in the table.  
2. The shaft-through portion is excluded. Refer to the asterisk 7 of "Annotations for Rotary Servo Motor Specifications" on p. 2-41 in this catalog for the shaft-through portion.  
3. When unbalanced torque is generated, such as in a vertical lift machine, keep the unbalanced torque of the machine under 70% of the servo motor rated torque.  
4. This value is applicable when the external regenerative resistors, GRZG400-Ω (standard accessory) are used with cooling fans (two units of 92 mm × 92 mm, minimum airflow: 1.0 m<sup>3</sup>/min). Note that [Pr. PA02] must be changed.  
5. Refer to "Servo Motor Instruction Manual (Vol. 3)" for the restrictions when using the servo motors at altitude exceeding 1000 m and up to 2000 m above sea level.  
6. The value in angle brackets is applicable when the servo motor is combined with MR-J4-DU900B4(-RJ) drive unit, and the maximum torque is increased with a parameter setting.  
7. This value is applicable when the servo motor is combined with MR-J4-GF4(-RJ)/MR-J4-B4(-RJ)/MR-J4-A4(-RJ) servo amplifier. Contact your local sales office for the regenerative braking frequency with MR-J4-DU\_B4(-RJ)/MR-J4-DU\_A4(-RJ) drive unit.  
8. The continuous running duty and the speed are not guaranteed when the power supply voltage is dropped.

Refer to "Annotations for Rotary Servo Motor Specifications" on p. 2-41 in this catalog for the asterisks 1 to 6.

**HG-JR 1500 r/min Series (400 V Class) Electromagnetic Brake Specifications (Note 1)**

Model	HG-JR	701M4B	11K1M4B	15K1M4B
Type	Spring actuated type safety brake			
Rated voltage	24 V DC <sub>-10%</sub>			
Power consumption [W] at 20 °C		32	32	32
Electromagnetic brake static friction torque [N·m]		126 or higher	126 or higher	126 or higher
Permissible braking work	Per braking [J]	5000	5000	5000
	Per hour [J]	45200	45200	45200
Electromagnetic brake life (Note 2)	Number of braking times	20000	20000	20000
	Work per braking [J]	400	400	400

Notes: 1. The electromagnetic brake is for holding. It cannot be used for deceleration applications.  
 2. Brake gap is not adjustable. Electromagnetic brake life is defined as the time period until readjustment is needed.

**HG-JR 1500 r/min Series (400 V Class) Torque Characteristics**

**HG-JR701M4(B)** (Note 1, 2, 3)    **HG-JR11K1M4(B)** (Note 1, 2, 3)    **HG-JR15K1M4(B)** (Note 1, 2, 3)    **HG-JR22K1M4** (Note 1, 2, 3)

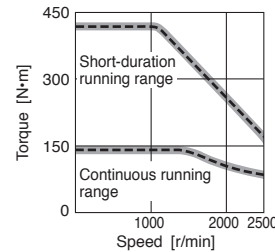
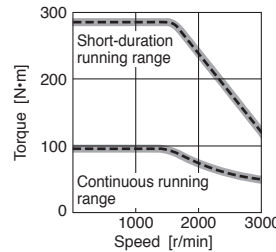
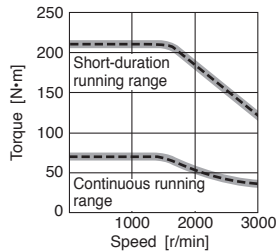
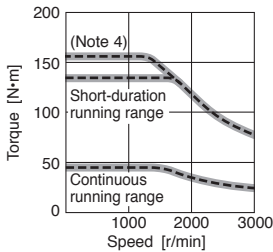

**HG-JR30K1M4** (Note 1, 2, 3)

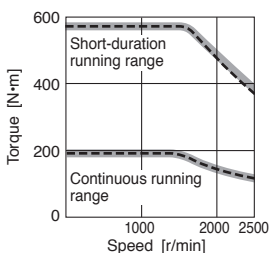

**HG-JR37K1M4** (Note 1, 2, 3)

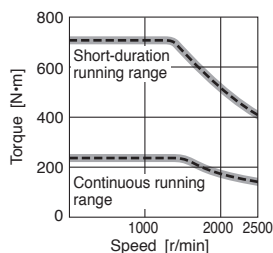

**HG-JR45K1M4** (Note 1, 2, 3)

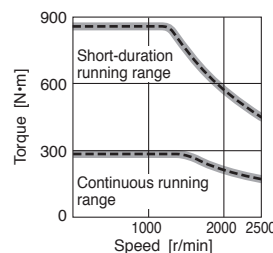

**HG-JR55K1M4** (Note 1, 2, 3)

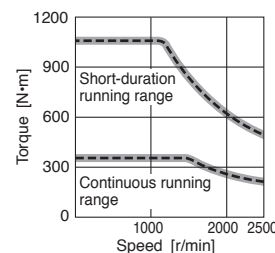

Notes: 1. — : For 3-phase 400 V AC.  
 2. - - - : For 3-phase 380 V AC.  
 3. Torque drops when the power supply voltage is below the specified value.  
 4. This value is applicable when the servo motor is combined with MR-J4-DU900B4(-RJ) drive unit, and the maximum torque is increased with a parameter setting.

**HG-JR 1500 r/min Series (400 V Class) Special Shaft End Specifications**

Motors with the following specifications are also available.

Key shaft (without key) (Note 1, 2)

Model	Variable dimensions								Fig.	
	S	R	Q	W	QK	QL	U	r		
HG-JR701M4(B)K	42h6	85	79	12 <sup>0</sup> <sub>-0.040</sub>	70	5	5 <sup>+0.2</sup> <sub>0</sub>	6	M8 screw Depth: 19.8	A
HG-JR11K1M4(B)K, 15K1M4(B)K	55m6	116	110	16 <sup>0</sup> <sub>-0.040</sub>	90	5	6 <sup>+0.2</sup> <sub>0</sub>	8	M10 screw Depth: 27	
HG-JR22K1M4K, 30K1M4K, 37K1M4K	65m6	140	130	18 <sup>0</sup> <sub>-0.040</sub>	120	5	7 <sup>+0.2</sup> <sub>0</sub>	9	M12 screw Depth: 25	
HG-JR45K1M4K, 55K1M4K	80m6	140	140	22 <sup>0</sup> <sub>-0.040</sub>	132	7	9 <sup>+0.2</sup> <sub>0</sub>	11	M16 screw Depth: 30	

Notes: 1. Do not use servo motors with key shafts for frequent start/stop applications as this may cause damage to the shaft.  
 2. A key is not supplied with the servo motor. The key shall be installed by the user.

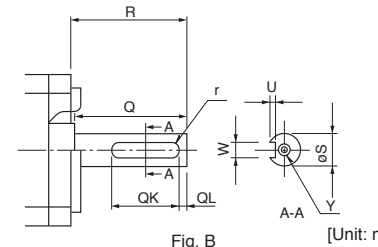
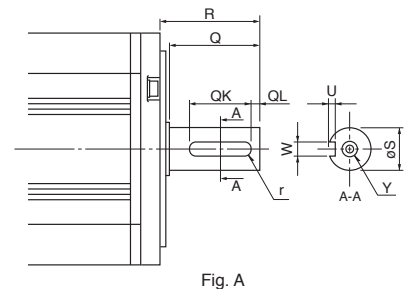

[Unit: mm]  
2-32

# Rotary Servo Motors

## HG-JR 2000 r/min Series (Low Inertia, Ultra-Large Capacity) (400 V Class) Specifications

Rotary servo motor model HG-JR		110K24W0C	150K24W0C	180K24W0C	200K24W0C	220K24W0C					
Compatible servo amplifier model	MR-J4-	Refer to "Combinations of Rotary Servo Motor and Servo Amplifier (Drive Unit and Power Regeneration Converter Unit)" on p. 2-9 in this catalog.									
Power supply capacity <sup>*1</sup>	[kVA]	156	213	256	284	312					
Continuous running duty (Note 5)	Rated output [kW]	110	150	180	200	220					
	Rated torque (Note 3) [N•m]	525	716	859	954	1050					
Maximum torque	[N•m]	1900	2600	3300	4100	3600					
Rated speed (Note 5)	[r/min]	2000									
Maximum speed (Note 5)	[r/min]	3000									
Permissible instantaneous speed	[r/min]	3450									
Power rate at continuous rated torque	[kW/s]	804	1184	1361	1334	799					
Rated current	[A]	170	295	293	357	357					
Maximum current	[A]	772	1344	1321	1653	1539					
Moment of inertia J	[x 10 <sup>-4</sup> kg•m <sup>2</sup> ]	3430	4330	5420	6820	13800					
Recommended load to motor inertia ratio (Note 1)		10 times or less									
Speed/position detector		Absolute/incremental 22-bit encoder (resolution: 4194304 pulses/rev)									
Type		Permanent magnet synchronous motor									
Oil seal		Installed									
Thermistor		Built-in									
Insulation class		155 (F)									
Structure		Totally enclosed, force cooling (IP rating: IP44) (Note 2)									
Environment <sup>*3</sup>	Ambient temperature	Operation: 0 °C to 40 °C (non-freezing), storage: -15 °C to 70 °C (non-freezing)									
	Ambient humidity	Operation: 10 %RH to 80 %RH (non-condensing), storage: 10 %RH to 90 %RH (non-condensing)									
	Ambience	Indoors (no direct sunlight); no corrosive gas, inflammable gas, oil mist or dust									
	Altitude	2000 m or less above sea level (Note 4)									
	Vibration resistance <sup>*4</sup>	X: 9.8 m/s <sup>2</sup> Y: 9.8 m/s <sup>2</sup>									
Vibration rank		V10 <sup>*6</sup>									
Permissible load for the shaft <sup>*5</sup>	L [mm]	175	175	175	175	200					
	Radial [N]	5000	5000	5000	5000	6000					
	Thrust [N]	5000	5000	5000	5000	5000					
Mass	[kg]	420	520	730	755	870					
Cooling fan (per fan)	Power supply voltage	1-phase 200 V AC	1-phase 200 V AC to 230 V AC	1-phase 200 V AC	1-phase 200 V AC to 230 V AC	1-phase 200 V AC	1-phase 200 V AC to 230 V AC	1-phase 200 V AC	1-phase 200 V AC to 230 V AC	1-phase 200 V AC	1-phase 200 V AC to 230 V AC
	Frequency [Hz]	50	60	50	60	50	60	50	60	50	60
	Input [W]	60	86	60	86	60	86	60	86	60	86
	Current [A]	0.4	0.5	0.4	0.5	0.4	0.5	0.4	0.5	0.4	0.5

Notes: 1. Contact your local sales office if the load to motor inertia ratio exceeds the value in the table.

2. The shaft-through portion is excluded. Refer to the asterisk 7 of "Annotations for Rotary Servo Motor Specifications" on p. 2-41 in this catalog for the shaft-through portion.

3. When unbalanced torque is generated, such as in a vertical lift machine, keep the unbalanced torque of the machine under 70% of the servo motor rated torque.

4. Refer to "Servo Motor Instruction Manual (Vol. 3)" for the restrictions when using the servo motors at altitude exceeding 1000 m and up to 2000 m above sea level.

5. The continuous running duty and the speed are not guaranteed when the power supply voltage is dropped.

Refer to "Annotations for Rotary Servo Motor Specifications" on p. 2-41 in this catalog for the asterisks 1 to 6.

### HG-JR 2000 r/min Series (400 V Class) Torque Characteristics

**HG-JR110K24W0C** (Note 1, 2, 3)

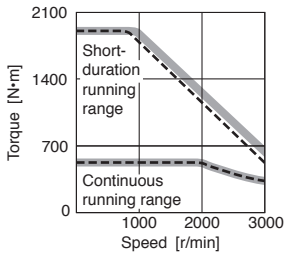

**HG-JR150K24W0C** (Note 1, 2, 3)

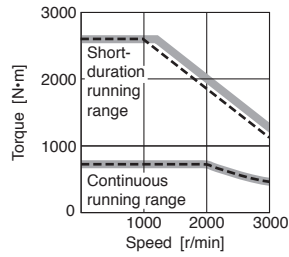

**HG-JR180K24W0C** (Note 1, 2, 3)

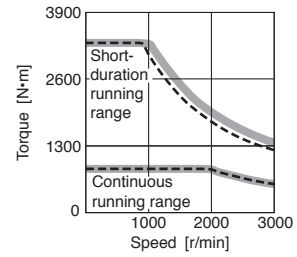

**HG-JR200K24W0C** (Note 1, 2, 3)

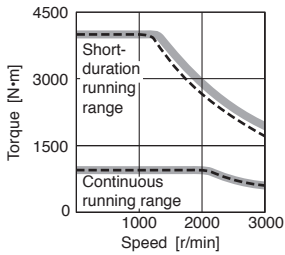

**HG-JR220K24W0C** (Note 1, 2, 3)

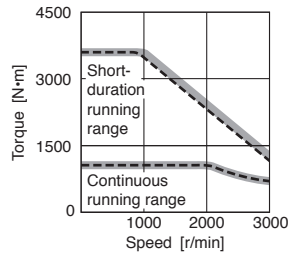

Notes: 1. — For 3-phase 400 V AC.  
 2. - - - For 3-phase 380 V AC.  
 3. Torque drops when the power supply voltage is below the specified value.

### HG-JR 2000 r/min Series (400 V Class) Special Shaft End Specifications

Motors with the following specifications are also available.

Key shaft (without key) (Note 1, 2)

Model	Variable dimensions								
	S	R	Q	W	QK	QL	U	r	Y
HG-JR110K24KW0C HG-JR150K24KW0C HG-JR180K24KW0C HG-JR200K24KW0C	95h6	175	165	25 <sup>0</sup> <sub>-0.04</sub>	135	5	9 <sup>+0.2</sup> <sub>0</sub>	12.5	M16 screw Depth: 30
HG-JR220K24KW0C	120h6	200	190	32 <sup>0</sup> <sub>-0.062</sub>	180	5	11 <sup>+0.2</sup> <sub>0</sub>	16	M24 screw Depth: 45

Notes: 1. Do not use servo motors with key shafts for frequent start/stop applications as this may cause damage to the shaft.  
 2. A key is not supplied with the servo motor. The key shall be installed by the user.

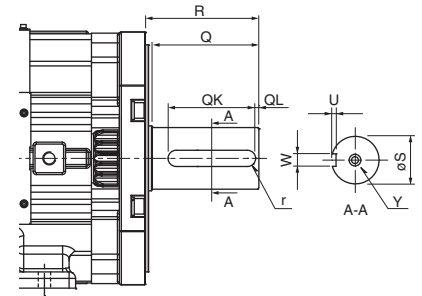

[Unit: mm]

# Rotary Servo Motors

## HG-RR Series (Ultra-Low Inertia, Medium Capacity) Specifications

Rotary servo motor model		HG-RR	103(B)	153(B)	203(B)	353(B)	503(B)
Compatible servo amplifier model		MR-J4-	Refer to "Combinations of Rotary Servo Motor and Servo Amplifier" on p. 2-5 in this catalog.				
Power supply capacity <sup>*1</sup>		[kVA]	1.7	2.5	3.5	5.5	7.5
Continuous running duty (Note 5)	Rated output	[kW]	1.0	1.5	2.0	3.5	5.0
	Rated torque (Note 3)	[N·m]	3.2	4.8	6.4	11.1	15.9
Maximum torque		[N·m]	8.0	11.9	15.9	27.9	39.8
Rated speed (Note 5)		[r/min]	3000				
Maximum speed (Note 5)		[r/min]	4500				
Permissible instantaneous speed		[r/min]	5175				
Power rate at continuous rated torque	Standard	[kW/s]	67.4	120	176	150	211
	With electromagnetic brake	[kW/s]	54.8	101	153	105	163
Rated current		[A]	6.1	8.8	14	23	28
Maximum current		[A]	18	23	37	58	70
Regenerative braking frequency <sup>*2</sup>	MR-J4-	[times/min]	1090	860	710	174	125
Moment of inertia J	Standard	[ $\times 10^{-4}$ kg·m <sup>2</sup> ]	1.50	1.90	2.30	8.30	12.0
	With electromagnetic brake	[ $\times 10^{-4}$ kg·m <sup>2</sup> ]	1.85	2.25	2.65	11.8	15.5
Recommended load to motor inertia ratio (Note 1)			5 times or less				
Speed/position detector			Absolute/incremental 22-bit encoder (resolution: 4194304 pulses/rev)				
Type			Permanent magnet synchronous motor				
Oil seal			Installed				
Thermistor			None				
Insulation class			155 (F)				
Structure			Totally enclosed, natural cooling (IP rating: IP65) (Note 2)				
Environment <sup>*3</sup>	Ambient temperature		Operation: 0 °C to 40 °C (non-freezing), storage: -15 °C to 70 °C (non-freezing)				
	Ambient humidity		Operation: 10 %RH to 80 %RH (non-condensing), storage: 10 %RH to 90 %RH (non-condensing)				
	Ambience		Indoors (no direct sunlight); no corrosive gas, inflammable gas, oil mist or dust				
	Altitude		2000 m or less above sea level (Note 4)				
Vibration resistance <sup>*4</sup>			X: 24.5 m/s <sup>2</sup> Y: 24.5 m/s <sup>2</sup>				
Vibration rank			V10 <sup>*6</sup>				
Permissible load for the shaft <sup>*5</sup>	L	[mm]	45	45	45	63	63
	Radial	[N]	686	686	686	980	980
	Thrust	[N]	196	196	196	392	392
Mass	Standard	[kg]	3.9	5.0	6.2	12	17
	With electromagnetic brake	[kg]	6.0	7.0	8.3	15	21

Notes: 1. Contact your local sales office if the load to motor inertia ratio exceeds the value in the table.

2. The shaft-through portion is excluded. Refer to the asterisk 7 of "Annotations for Rotary Servo Motor Specifications" on p. 2-41 in this catalog for the shaft-through portion.

3. When unbalanced torque is generated, such as in a vertical lift machine, keep the unbalanced torque of the machine under 70% of the servo motor rated torque.

4. Refer to "Servo Motor Instruction Manual (Vol. 3)" for the restrictions when using the servo motors at altitude exceeding 1000 m and up to 2000 m above sea level.

5. The continuous running duty and the speed are not guaranteed when the power supply voltage is dropped.

Refer to "Annotations for Rotary Servo Motor Specifications" on p. 2-41 in this catalog for the asterisks 1 to 6.



**HG-RR Series Electromagnetic Brake Specifications** (Note 1)

Model	HG-RR	103B	153B	203B	353B	503B
Type	Spring actuated type safety brake					
Rated voltage	24 V DC <sub>-10%</sub>					
Power consumption [W] at 20 °C		19	19	19	23	23
Electromagnetic brake static friction torque [N·m]		7.0 or higher	7.0 or higher	7.0 or higher	17 or higher	17 or higher
Permissible braking work	Per braking [J]	400	400	400	400	400
	Per hour [J]	4000	4000	4000	4000	4000
Electromagnetic brake life (Note 2)	Number of braking times	20000	20000	20000	20000	20000
	Work per braking [J]	200	200	200	200	200

Notes: 1. The electromagnetic brake is for holding. It cannot be used for deceleration applications.  
 2. Brake gap is not adjustable. Electromagnetic brake life is defined as the time period until readjustment is needed.

**HG-RR Series Torque Characteristics**

**HG-RR103(B)** (Note 1, 2, 3, 4)

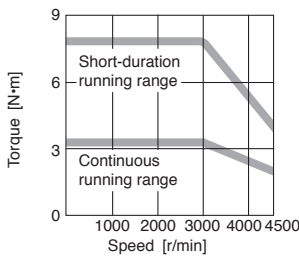

**HG-RR153(B)** (Note 1, 2, 3, 4)

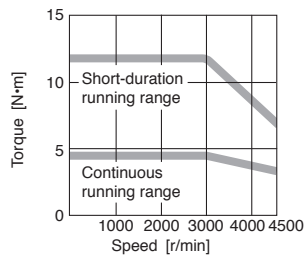

**HG-RR203(B)** (Note 1, 2)

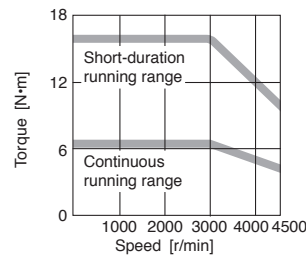

**HG-RR353(B)** (Note 1, 2)

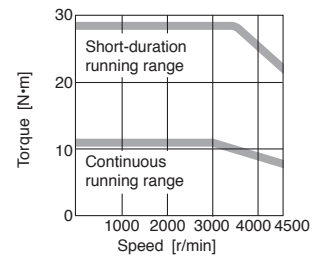

**HG-RR503(B)** (Note 1, 2)

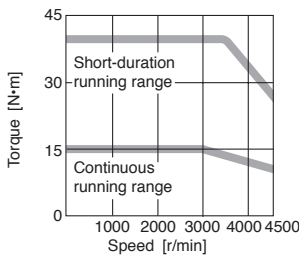

Notes: 1. — : For 3-phase 200 V AC.  
 2. Torque drops when the power supply voltage is below the specified value.  
 3. Contact your local sales office for the torque characteristics when using the servo amplifier with 1-phase 200 V AC input.  
 4. When using a combination of the servo motors and MR-J4-100\_ or MR-J4-200\_ with a 1-phase power supply, use the servo amplifiers at 75 % or less of the effective load ratio.

**HG-RR Series Special Shaft End Specifications**

Motors with the following specifications are also available.

Key shaft (without key) (Note 1, 2)

Model	Variable dimensions								
	S	R	Q	W	QK	QL	U	r	Y
HG-RR103(B)K, 153(B)K, 203(B)K	24h6	45	40	8 <sup>0</sup> <sub>-0.036</sub>	25	5	4 <sup>+0.2</sup> <sub>0</sub>	4	M8 screw Depth: 20
HG-RR353(B)K, 503(B)K	28h6	63	58	8 <sup>0</sup> <sub>-0.036</sub>	53	3	4 <sup>+0.2</sup> <sub>0</sub>	4	

Notes: 1. Do not use servo motors with key shafts for frequent start/stop applications as this may cause damage to the shaft.  
 2. A key is not supplied with the servo motor. The key shall be installed by the user.

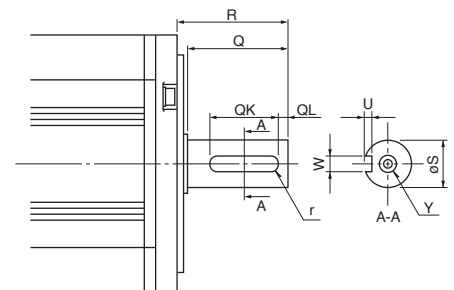

[Unit: mm]

Servo Amplifiers  
 Rotary Servo Motors  
 Linear Servo Motors  
 Direct Drive Motors  
 Options/Peripheral Equipment  
 LVS/Wires  
 Product List  
 Precautions

# Rotary Servo Motors

## HG-UR Series (Flat Type, Medium Capacity) Specifications

Rotary servo motor model		HG-UR	72(B)	152(B)	202(B)	352(B)	502(B)
Compatible servo amplifier model		MR-J4- MR-J4W_-	Refer to "Combinations of Rotary Servo Motor and Servo Amplifier" on p. 2-5 in this catalog.				
Power supply capacity <sup>*1</sup>		[kVA]	1.3	2.5	3.5	5.5	7.5
Continuous running duty (Note 5)	Rated output	[kW]	0.75	1.5	2.0	3.5	5.0
	Rated torque (Note 3)	[N·m]	3.6	7.2	9.5	16.7	23.9
Maximum torque		[N·m]	10.7	21.5	28.6	50.1	71.6
Rated speed (Note 5)		[r/min]	2000				
Maximum speed (Note 5)		[r/min]	3000			2500	
Permissible instantaneous speed		[r/min]	3450			2875	
Power rate at continuous rated torque	Standard	[kW/s]	12.3	23.2	23.9	36.5	49.6
	With electromagnetic brake	[kW/s]	10.3	21.2	19.5	32.8	46.0
Rated current		[A]	5.4	9.7	14	23	28
Maximum current		[A]	16	29	42	69	84
Regenerative braking frequency <sup>*2</sup>	MR-J4-	[times/min]	53	124	68	44	31
	MR-J4W_-	[times/min]	107	-	-	-	-
Moment of inertia J	Standard	[× 10 <sup>-4</sup> kg·m <sup>2</sup> ]	10.4	22.1	38.2	76.5	115
	With electromagnetic brake	[× 10 <sup>-4</sup> kg·m <sup>2</sup> ]	12.5	24.2	46.8	85.1	124
Recommended load to motor inertia ratio (Note 1)			15 times or less				
Speed/position detector			Absolute/incremental 22-bit encoder (resolution: 4194304 pulses/rev)				
Type			Permanent magnet synchronous motor				
Oil seal			Installed				
Thermistor			None				
Insulation class			155 (F)				
Structure			Totally enclosed, natural cooling (IP rating: IP65) (Note 2)				
Environment <sup>*3</sup>	Ambient temperature		Operation: 0 °C to 40 °C (non-freezing), storage: -15 °C to 70 °C (non-freezing)				
	Ambient humidity		Operation: 10 %RH to 80 %RH (non-condensing), storage: 10 %RH to 90 %RH (non-condensing)				
	Ambience		Indoors (no direct sunlight); no corrosive gas, inflammable gas, oil mist or dust				
	Altitude		2000 m or less above sea level (Note 4)				
Vibration resistance <sup>*4</sup>			X: 24.5 m/s <sup>2</sup> Y: 24.5 m/s <sup>2</sup>		X: 24.5 m/s <sup>2</sup> Y: 49 m/s <sup>2</sup>		
Vibration rank			V10 <sup>*6</sup>				
Permissible load for the shaft <sup>*5</sup>	L	[mm]	55	55	65	65	65
	Radial	[N]	637	637	882	1176	1176
	Thrust	[N]	490	490	784	784	784
Mass	Standard	[kg]	8.0	11	16	20	24
	With electromagnetic brake	[kg]	10	13	22	26	30

Notes: 1. Contact your local sales office if the load to motor inertia ratio exceeds the value in the table.

2. The shaft-through portion is excluded. Refer to the asterisk 7 of "Annotations for Rotary Servo Motor Specifications" on p. 2-41 in this catalog for the shaft-through portion.

3. When unbalanced torque is generated, such as in a vertical lift machine, keep the unbalanced torque of the machine under 70% of the servo motor rated torque.

4. Refer to "Servo Motor Instruction Manual (Vol. 3)" for the restrictions when using the servo motors at altitude exceeding 1000 m and up to 2000 m above sea level.

5. The continuous running duty and the speed are not guaranteed when the power supply voltage is dropped.

Refer to "Annotations for Rotary Servo Motor Specifications" on p. 2-41 in this catalog for the asterisks 1 to 6.

**HG-UR Series Electromagnetic Brake Specifications (Note 1)**

Model		HG-UR	72B	152B	202B	352B	502B
Type		Spring actuated type safety brake					
Rated voltage		24 V DC <sub>-10%</sub>					
Power consumption [W] at 20 °C		19	19	34	34	34	
Electromagnetic brake static friction torque [N·m]		8.5 or higher	8.5 or higher	44 or higher	44 or higher	44 or higher	
Permissible braking work	Per braking [J]	400	400	4500	4500	4500	
	Per hour [J]	4000	4000	45000	45000	45000	
Electromagnetic brake life (Note 2)	Number of braking times	20000	20000	20000	20000	20000	
	Work per braking [J]	200	200	1000	1000	1000	

Notes: 1. The electromagnetic brake is for holding. It cannot be used for deceleration applications.  
 2. Brake gap is not adjustable. Electromagnetic brake life is defined as the time period until readjustment is needed.

**HG-UR Series Torque Characteristics**

**HG-UR72(B)** (Note 1, 2, 3, 4)

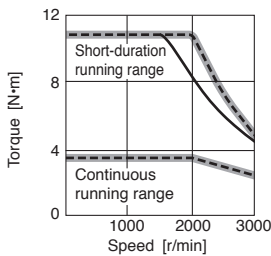

**HG-UR152(B)** (Note 1, 4, 5, 6)

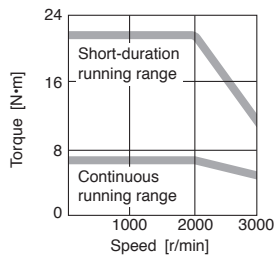

**HG-UR202(B)** (Note 1, 4)

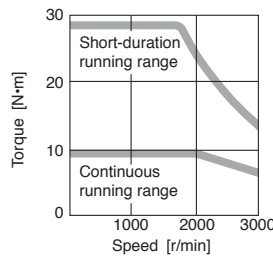

**HG-UR352(B)** (Note 1, 4)

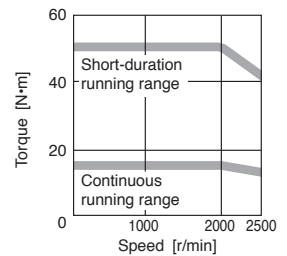

**HG-UR502(B)** (Note 1, 4)

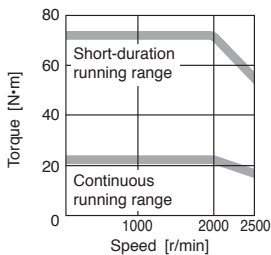

Notes: 1. ——— : For 3-phase 200 V AC.  
 2. - - - - : For 1-phase 230 V AC.  
 3. ——— : For 1-phase 200 V AC. This line is only drawn where it differs from the other two lines.  
 4. Torque drops when the power supply voltage is below the specified value.  
 5. Contact your local sales office for the torque characteristics when using the servo amplifier with 1-phase 200 V AC input.  
 6. When using a combination of the servo motors and MR-J4-100\_ or MR-J4-200\_ with a 1-phase power supply, use the servo amplifiers at 75 % or less of the effective load ratio.

**HG-UR Series Special Shaft End Specifications**

Motors with the following specifications are also available.

Key shaft (without key) (Note 1, 2)

Model	Variable dimensions								
	S	R	Q	W	QK	QL	U	r	Y
HG-UR72(B)K	22h6	55	50	6 <sup>0</sup> <sub>-0.036</sub>	42	3	3.5 <sup>+0.1</sup> <sub>0</sub>	3	M8 screw Depth: 20
HG-UR152(B)K	28h6	55	50	8 <sup>0</sup> <sub>-0.036</sub>	40	3	4 <sup>+0.2</sup> <sub>0</sub>	4	
HG-UR202(B)K, 352(B)K, 502(B)K	35 <sup>+0.010</sup> <sub>0</sub>	65	60	10 <sup>0</sup> <sub>-0.036</sub>	50	5	5 <sup>+0.2</sup> <sub>0</sub>	5	

Notes: 1. Do not use servo motors with key shafts for frequent start/stop applications as this may cause damage to the shaft.  
 2. A key is not supplied with the servo motor. The key shall be installed by the user.

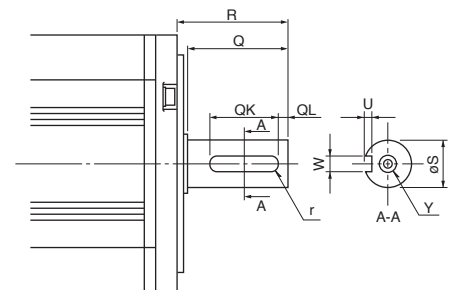

[Unit: mm]

# Rotary Servo Motors

## HG-AK Series (Ultra-Compact Size, Ultra-Small Capacity) Specifications (Note 4)

Servo motor model		HG-AK	0136(B)	0236(B)	0336(B)
Compatible servo amplifier model		Refer to "Combinations of Rotary Servo Motor and Servo Amplifier" on p. 2-7 in this catalog.			
Power supply capacity <sup>*8</sup>		[W]	230	360	480
Continuous running duty (Note 5)	Rated output	[W]	10	20	30
	Rated torque (Note 3)	[N·m]	0.032	0.064	0.095
Maximum torque		[N·m]	0.095	0.191	0.286
Rated speed (Note 5)		[r/min]	3000		
Maximum speed (Note 5)	48 V DC	[r/min]	6000		5000
	24 V DC	[r/min]	6000		
Permissible instantaneous speed	48 V DC	[r/min]	6900		
	24 V DC	[r/min]	6900		5750
Power rate at continuous rated torque	Standard	[kW/s]	3.54	9.01	14.95
	With electromagnetic brake	[kW/s]	2.41	6.99	12.32
Rated current		[A]	2.1	2.1	2.2
Maximum current		[A]	6.3	6.3	6.6
Regenerative braking frequency <sup>*2</sup>		[times/min]	1700	1200	900
Moment of inertia J	Standard	[× 10 <sup>-4</sup> kg·m <sup>2</sup> ]	0.0029	0.0045	0.0061
	With electromagnetic brake	[× 10 <sup>-4</sup> kg·m <sup>2</sup> ]	0.0042	0.0058	0.0074
Recommended load to motor inertia ratio (Note 1)			30 times or less		
Speed/position detector			Absolute/incremental 18-bit encoder (resolution: 262144 pulses/rev)		
Type			Permanent magnet synchronous motor		
Oil seal			None		
Thermistor			None		
Insulation class			130 (B)		
Structure			Totally enclosed, natural cooling (IP rating: IP55) (Note 2)		
Environment <sup>*3</sup>	Ambient temperature		Operation: 0 °C to 40 °C (non-freezing), storage: -15 °C to 70 °C (non-freezing)		
	Ambient humidity		Operation: 10 %RH to 80 %RH (non-condensing), storage: 10 %RH to 90 %RH (non-condensing)		
	Ambience		Indoors (no direct sunlight); no corrosive gas, inflammable gas, oil mist or dust		
	Altitude		1000 m or less above sea level		
Vibration resistance <sup>*4</sup>			X: 49 m/s <sup>2</sup> Y: 49 m/s <sup>2</sup>		
Vibration rank			V10 <sup>*6</sup>		
Permissible load for the shaft <sup>*5</sup>	L	[mm]	16	16	16
	Radial	[N]	34	44	49
	Thrust	[N]	14	14	14
Mass	Standard	[kg]	0.12	0.14	0.16
	With electromagnetic brake	[kg]	0.22	0.24	0.26

Notes: 1. Contact your local sales office if the load to motor inertia ratio exceeds the value in the table.

2. The shaft-through portion, the connector, and the power cable leading part are excluded. Refer to the asterisk 7 of "Annotations for Rotary Servo Motor Specifications" on p. 2-41 in this catalog for the shaft-through portion.

3. When unbalanced torque is generated, such as in a vertical lift machine, keep the unbalanced torque of the machine under 70% of the servo motor rated torque.

4. Specifications of HG-AK\_S100 are the same as those of HG-AK\_ except for the dimensions.

5. The continuous running duty and the speed are not guaranteed when the power supply voltage is dropped.

Refer to "Annotations for Rotary Servo Motor Specifications" on p. 2-41 in this catalog for the asterisks 2 to 6 and 8.

**HG-AK Series Electromagnetic Brake Specifications** (Note 1)

Model	HG-AK	0136B	0236B	0336B
Type	Spring actuated type safety brake			
Rated voltage	24 V DC <sub>-10%</sub>			
Power consumption [W] at 20 °C	1.8			
Electromagnetic brake static friction torque [N·m]	0.095 or higher			
Permissible braking work	Per braking [J]	4.6		
	Per hour [J]	46		
Electromagnetic brake life (Note 2)	Number of braking times	20000		
	Work per braking [J]	1		

Notes: 1. The electromagnetic brake is for holding. It cannot be used for deceleration applications.  
 2. Brake gap is not adjustable. Electromagnetic brake life is defined as the time period until readjustment is needed.

**HG-AK Series Torque Characteristics**

**HG-AK0136(B)** (Note 1, 2, 3, 4)

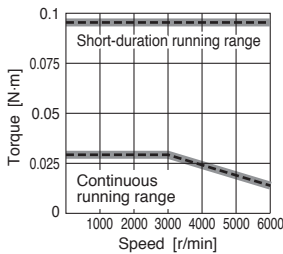

**HG-AK0236(B)** (Note 1, 2, 3, 4)

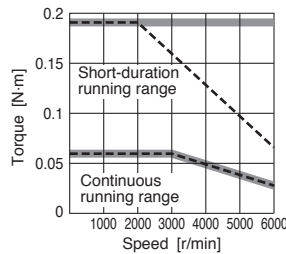

**HG-AK0336(B)** (Note 1, 2, 3, 4)

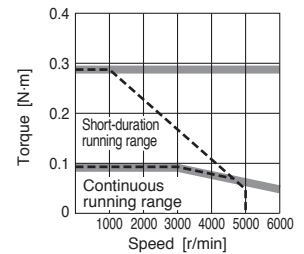

- Notes: 1. —: For 48 V DC.  
 2. - - -: For 24 V DC.  
 3. Torque drops when the power supply voltage is below the specified value.  
 4. The torque characteristics are applicable when option MR-J4W03PWCBL5M-H or MR-J4W03PWBRCL5M-H is used between the servo amplifier and the servo motor. When an option cable longer than 5 m is used, the torque characteristics in the short-duration running range may be lower because of voltage drop.

**HG-AK Series Special Shaft End Specifications** (Note 1)

Motors with the following specifications are also available.

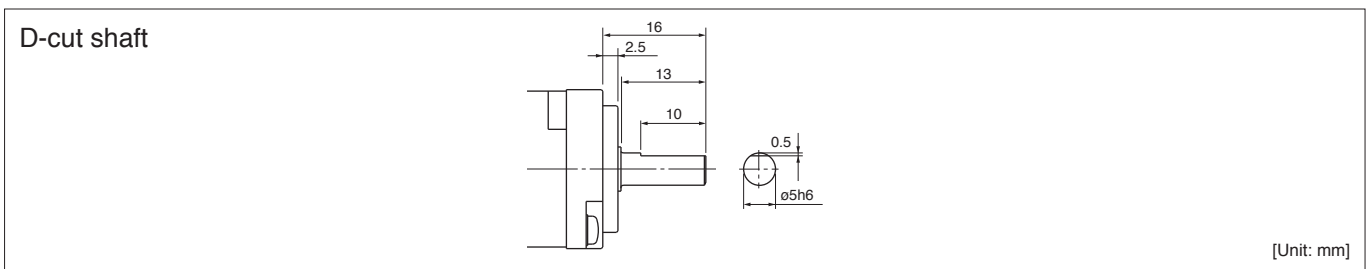

Notes: 1. Specifications of HG-AK\_-S100 are the same as those of HG-AK\_ except for the dimensions.

# Rotary Servo Motors

## Annotations for Rotary Servo Motor Specifications

- \* 1. The power supply capacity varies depending on the power supply impedance.  
The listed values are the power supply capacity for one servo motor. For the multi-axis servo amplifiers, calculate the power supply capacity with the equation below:  
Power supply capacity [kVA] = Sum of power supply capacity [kVA] of the connected servo motors
- \* 2. The regenerative braking frequency shows the permissible frequency when the servo motor, without a load and a regenerative option, decelerates from the rated speed to a stop. When a load is connected, the value will be the table value/(m+1), where m = Moment of inertia of load/Moment of inertia of servo motor.  
When the operating speed exceeds the rated speed, the regenerative braking frequency is inversely proportional to the square of (operating speed/rated speed). Take measures to keep the regenerative power [W] during operation below the permissible regenerative power [W]. Use caution, especially when the operating speed changes frequently or when the regeneration is constant (as with vertical feeds). Select the most suitable regenerative option for your system with our drive system sizing software Motorizer. Refer to "Regenerative Option" in this catalog for the permissible regenerative power [W] when a regenerative option is used.
- \* 3. In the environment where the servo motor is exposed to oil mist, oil and/or water, a standard specification servo motor may not be usable. Contact your local sales office for more details.
- \* 4. The vibration direction is shown in the diagram below. The numerical value indicates the maximum value of the component (commonly the bracket in the opposite direction of the load side).  
Fretting tends to occur on the bearing when the servo motor stops. Thus, maintain vibration level at approximately one-half of the allowable value.

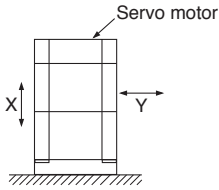

- \* 5. Refer to the diagram below for the permissible load for the shaft. Ensure that loads applied on the shaft do not exceed the values specified in the table. The values in the table are applicable when each load is applied singly.

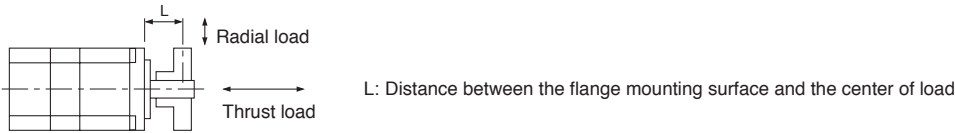

- \* 6. V10 indicates that the amplitude of the servo motor itself is 10 μm or less. The following shows mounting orientation and measuring position of the servo motor during the measurement:

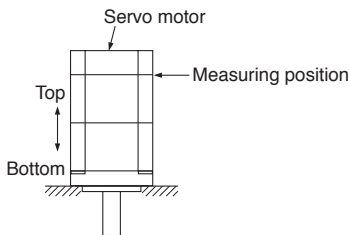

- \* 7. Refer to the diagram below for shaft-through portion.

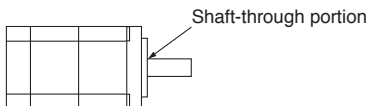

- \* 8. The power supply capacity varies depending on the DC power supply and the wiring impedance.  
The listed values are the power supply capacity for one servo motor. For the multi-axis servo amplifiers, calculate the power supply capacity with the equation below:  
Power supply capacity [W] = Sum of power supply capacity [W] of the connected servo motors

**HG-KR/HG-MR Series Dimensions** (Note 1, 5, 6)

- HG-KR053(B), HG-KR13(B)
- HG-MR053(B), HG-MR13(B)

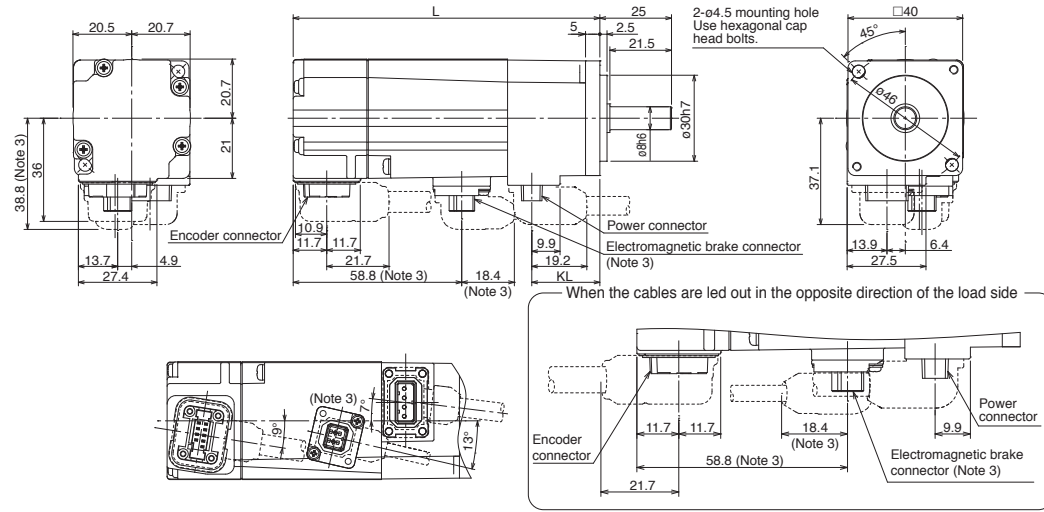

Power connector

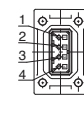

Pin No.	Signal name
1	E
2	U
3	V
4	W

Electromagnetic brake connector (Note 2)



Pin No.	Signal name
1	B1
2	B2

Model	Variable dimensions (Note 4)	
	L	KL
HG-KR053(B) HG-MR053(B)	66.4 (107)	23.8
HG-KR13(B) HG-MR13(B)	82.4 (123)	39.8

[Unit: mm]

- HG-KR23(B), HG-KR43(B)
- HG-MR23(B), HG-MR43(B)

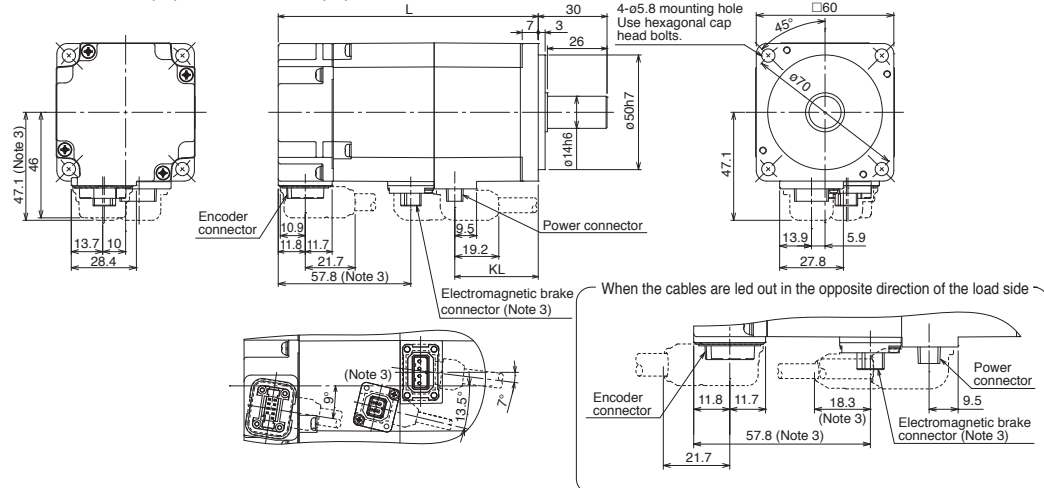

Power connector

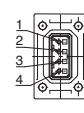

Pin No.	Signal name
1	E
2	U
3	V
4	W

Electromagnetic brake connector (Note 2)



Pin No.	Signal name
1	B1
2	B2

Model	Variable dimensions (Note 4)	
	L	KL
HG-KR23(B) HG-MR23(B)	76.6 (113.4)	36.4
HG-KR43(B) HG-MR43(B)	98.3 (135.1)	58.1

[Unit: mm]

- HG-KR73(B)
- HG-MR73(B)

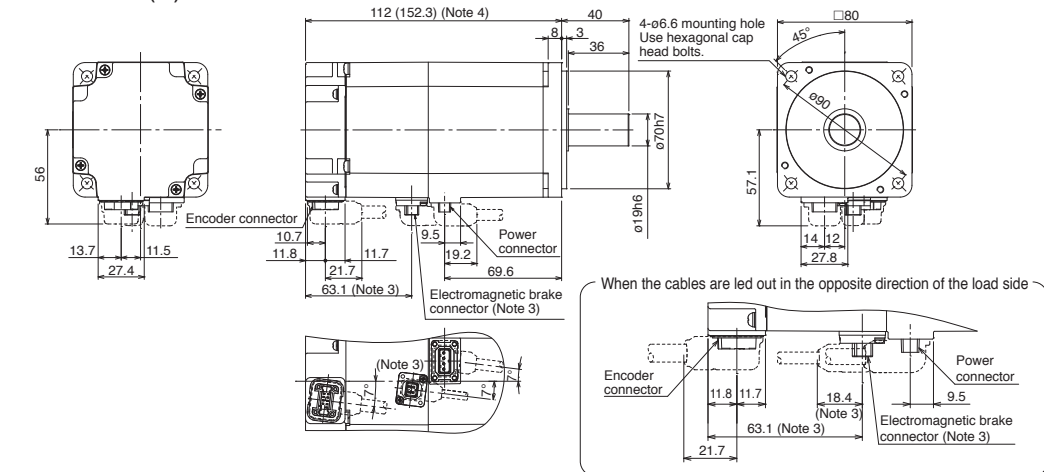

Power connector

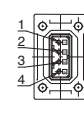

Pin No.	Signal name
1	E
2	U
3	V
4	W

Electromagnetic brake connector (Note 2)



Pin No.	Signal name
1	B1
2	B2

[Unit: mm]

Notes: 1. For dimensions without tolerance, general tolerance applies.  
 2. The electromagnetic brake terminals (B1, B2) do not have polarity.  
 3. Only for the models with electromagnetic brake.  
 4. Dimensions in brackets are for the models with electromagnetic brake.  
 5. Use a friction coupling to fasten a load.  
 6. Servo motors with oil seal (HG-KR\_J and HG-MR\_J) have different dimensions. Contact your local sales office for more details.

# Rotary Servo Motors

## HG-SR Series Dimensions (Note 1, 5, 6)

- HG-SR51(B), HG-SR81(B)
- HG-SR52(B), HG-SR102(B), HG-SR152(B),  
HG-SR524(B), HG-SR1024(B), HG-SR1524(B)

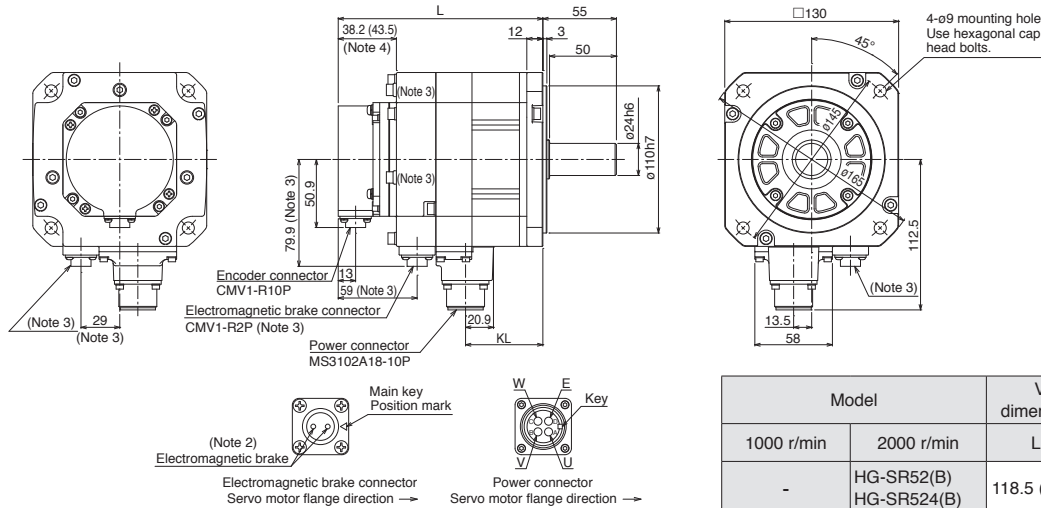

Model		Variable dimensions (Note 4)	
1000 r/min	2000 r/min	L	KL
-	HG-SR52(B) HG-SR524(B)	118.5 (153)	57.8
HG-SR51(B)	HG-SR102(B) HG-SR1024(B)	132.5 (167)	71.8
HG-SR81(B)	HG-SR152(B) HG-SR1524(B)	146.5 (181)	85.8

[Unit: mm]

- HG-SR121(B), HG-SR201(B), HG-SR301(B), HG-SR421(B)
- HG-SR202(B), HG-SR352(B), HG-SR502(B), HG-SR702(B),  
HG-SR2024(B), HG-SR3524(B), HG-SR5024(B), HG-SR7024(B)

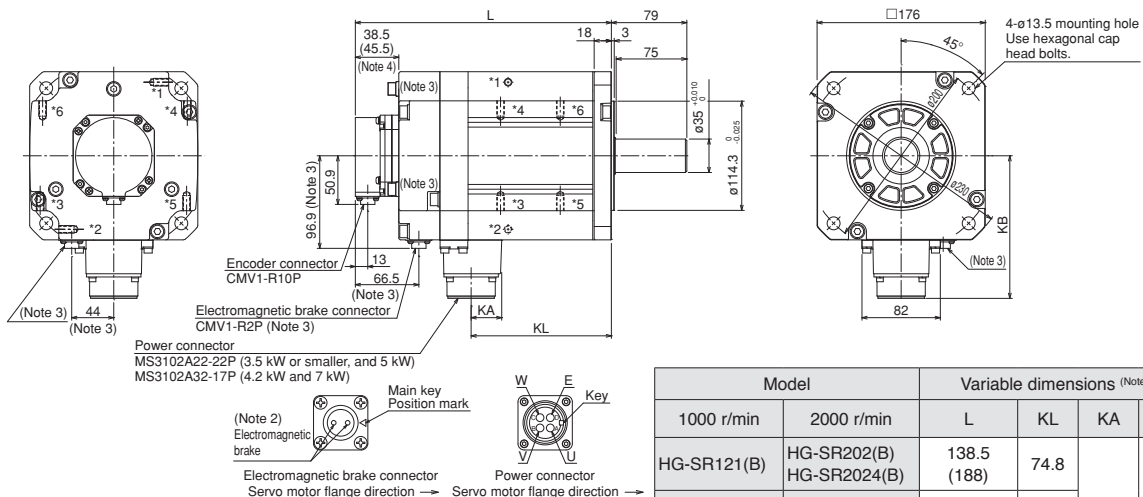

Model		Variable dimensions (Note 4)			
1000 r/min	2000 r/min	L	KL	KA	KB
HG-SR121(B)	HG-SR202(B) HG-SR2024(B)	138.5 (188)	74.8		
HG-SR201(B)	HG-SR352(B) HG-SR3524(B)	162.5 (212)	98.8	24.8	140.9
HG-SR301(B)	HG-SR502(B) HG-SR5024(B)	178.5 (228)	114.8		
HG-SR421(B)	HG-SR702(B) HG-SR7024(B)	218.5 (268)	146.8	32	149.1

\*1, \*2, \*3, \*4, \*5 and \*6 are screw holes (M8) for eyebolt.  
 \*HG-SR201(B), 301(B), 352(4)(B), 502(4)(B): \*1, \*2  
 \*HG-SR421(B), 702(4)(B): \*3, \*4, \*5, \*6

[Unit: mm]

- Notes: 1. For dimensions without tolerance, general tolerance applies.  
 2. The electromagnetic brake terminals do not have polarity.  
 3. Only for the models with electromagnetic brake.  
 4. Dimensions in brackets are for the models with electromagnetic brake.  
 5. Use a friction coupling to fasten a load.  
 6. For HG-SR series, dimensions are the same regardless of whether or not oil seal is installed.



## HG-JR Series Dimensions (Note 1, 5)

- HG-JR53(B), HG-JR73(B), HG-JR103(B), HG-JR153(B), HG-JR203(B), HG-JR534(B), HG-JR734(B), HG-JR1034(B), HG-JR1534(B), HG-JR2034(B)

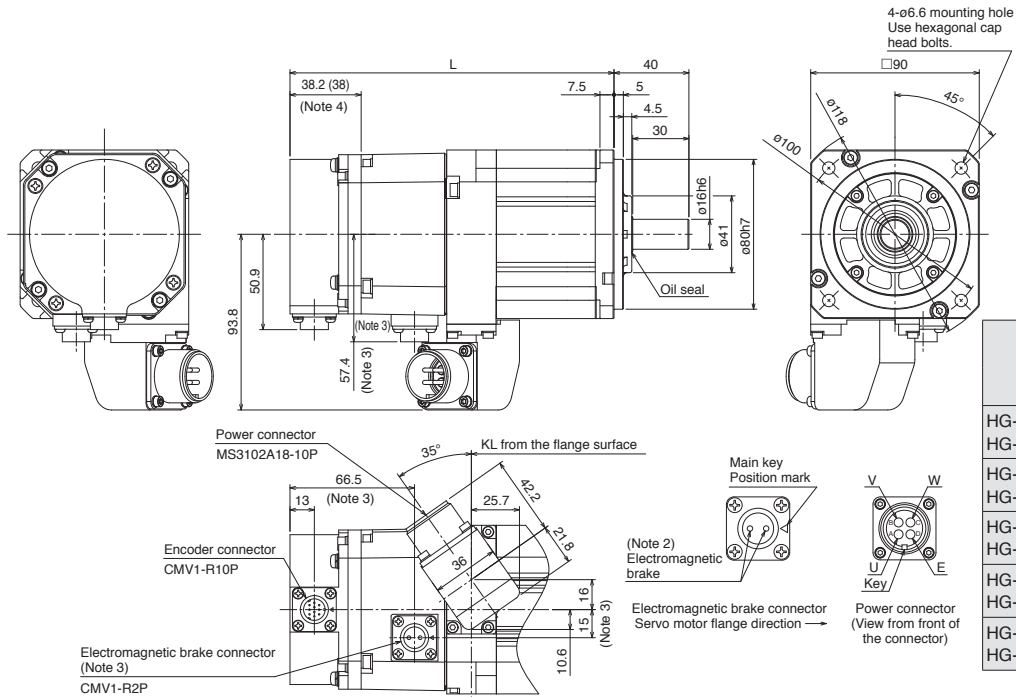

[Unit: mm]

- HG-JR353(B), HG-JR503(B)

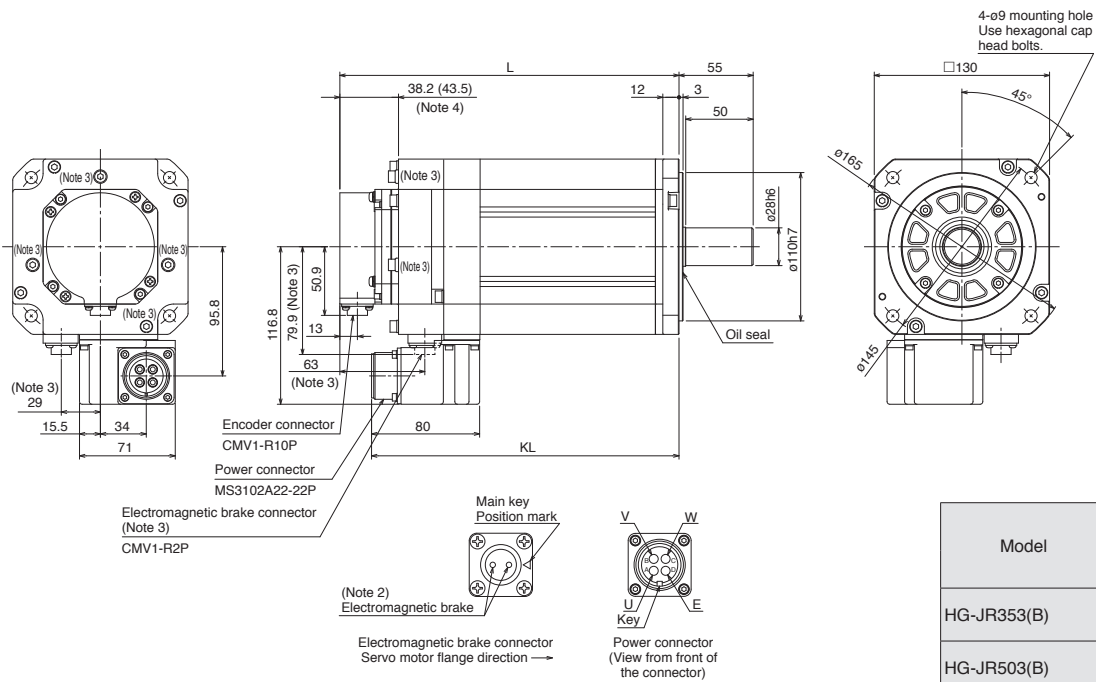

[Unit: mm]

- Notes: 1. For dimensions without tolerance, general tolerance applies.  
 2. The electromagnetic brake terminals do not have polarity.  
 3. Only for the models with electromagnetic brake.  
 4. Dimensions in brackets are for the models with electromagnetic brake.  
 5. Use a friction coupling to fasten a load.

# Rotary Servo Motors

## HG-JR Series Dimensions (Note 1, 5)

### ●HG-JR3534(B), HG-JR5034(B)

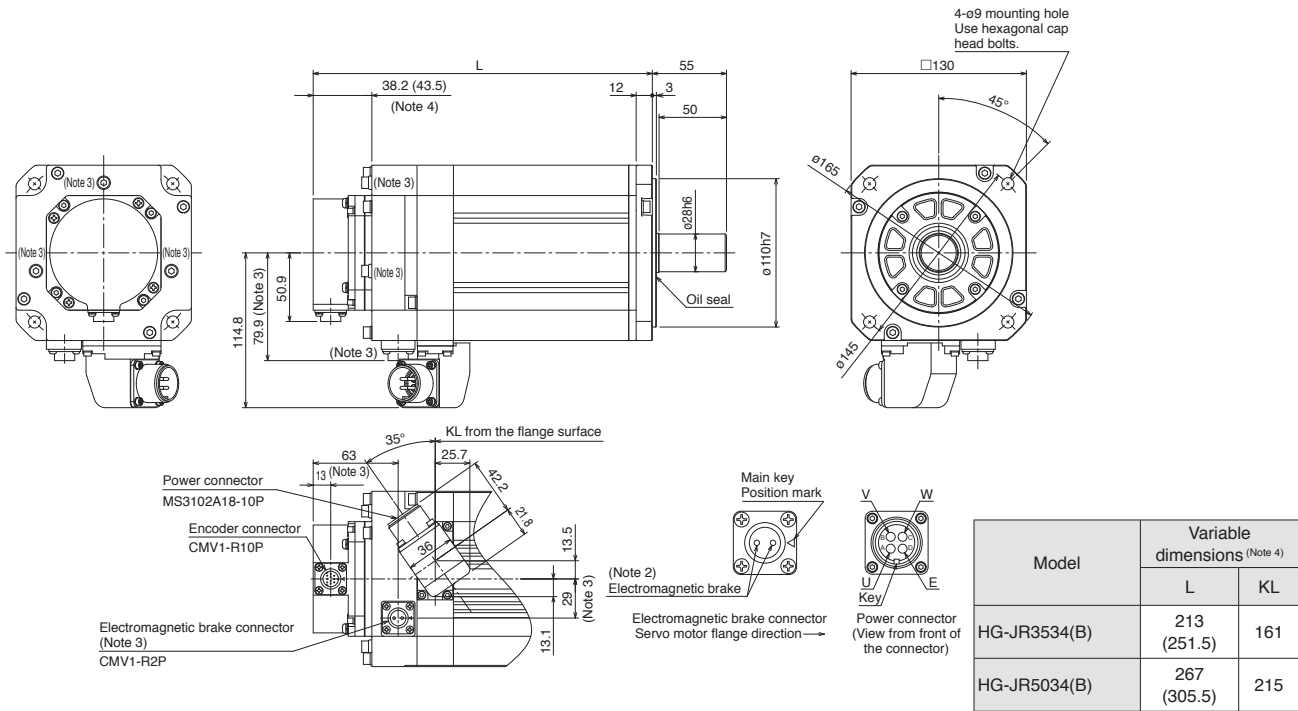

[Unit: mm]

### ●HG-JR703(B), HG-JR903(B), HG-JR7034(B), HG-JR9034(B)

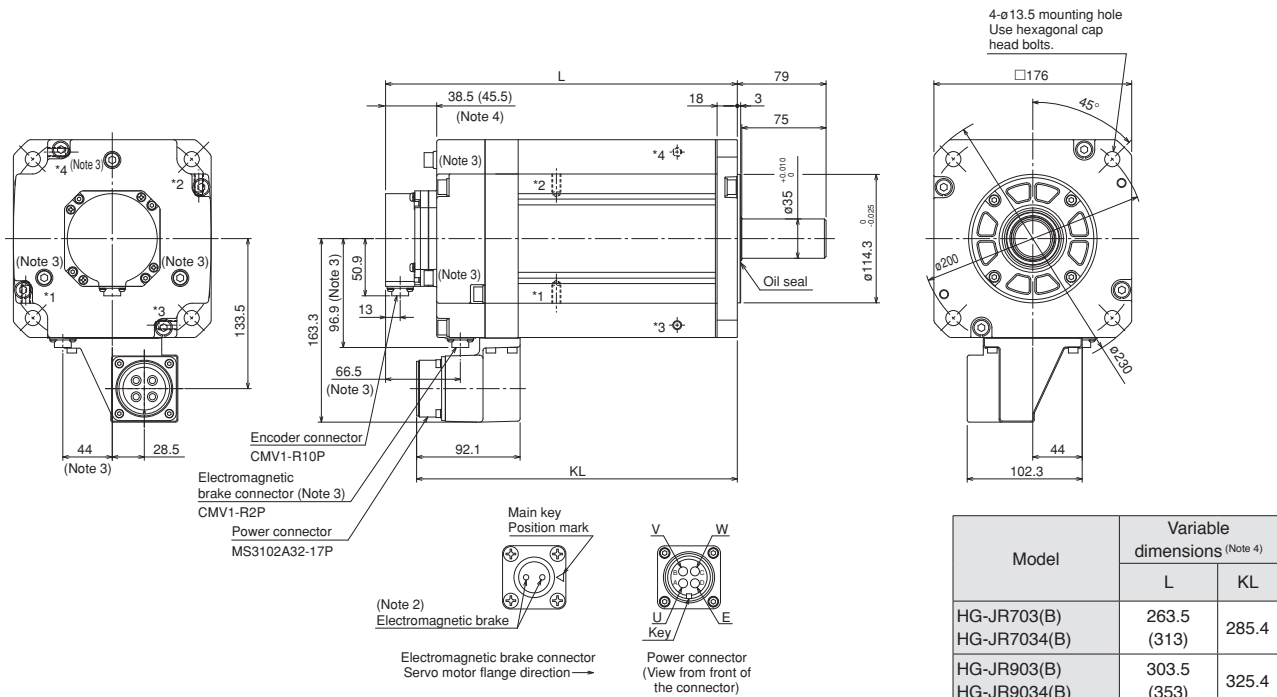

\*1, \*2, \*3, and \*4 are screw holes (M8) for eyebolt.

[Unit: mm]

- Notes: 1. For dimensions without tolerance, general tolerance applies.  
 2. The electromagnetic brake terminals do not have polarity.  
 3. Only for the models with electromagnetic brake.  
 4. Dimensions in brackets are for the models with electromagnetic brake.  
 5. Use a friction coupling to fasten a load.

**HG-JR Series Dimensions** (Note 1, 5)

- HG-JR601(B), HG-JR701M(B), HG-JR6014(B), HG-JR701M4(B)

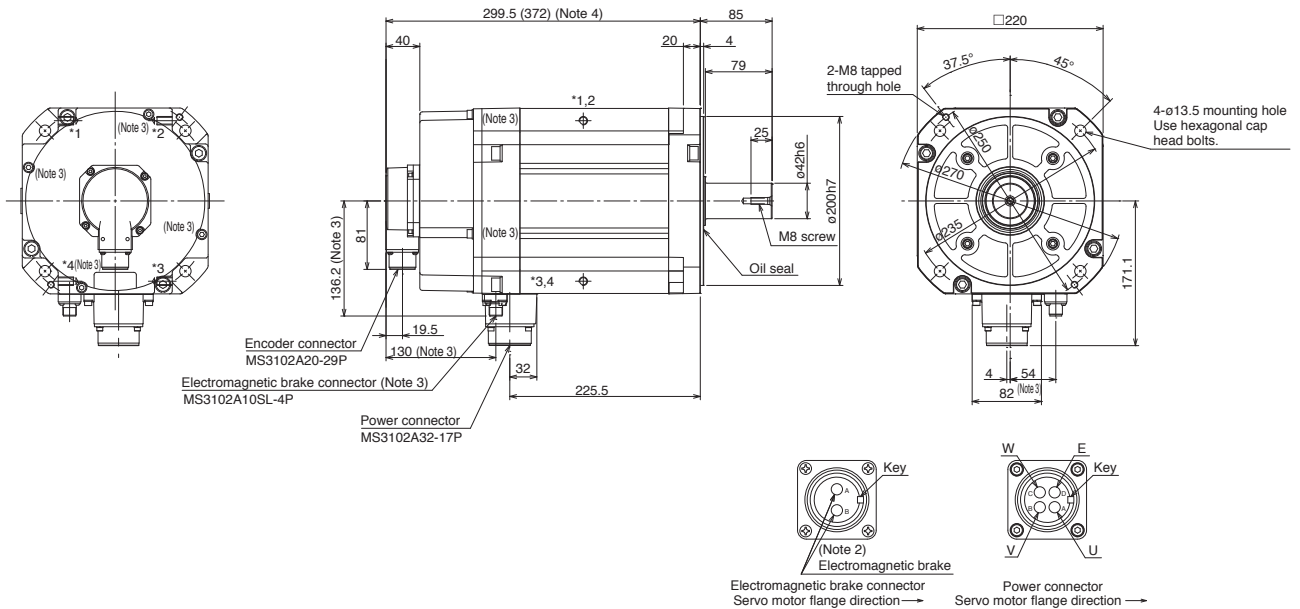

\*1, \*2, \*3, and \*4 are screw holes (M10) for eyebolt.

[Unit: mm]

- HG-JR801(B), HG-JR12K1(B), HG-JR8014(B), HG-JR12K14(B)
- HG-JR11K1M(B), HG-JR15K1M(B), HG-JR11K1M4(B), HG-JR15K1M4(B)

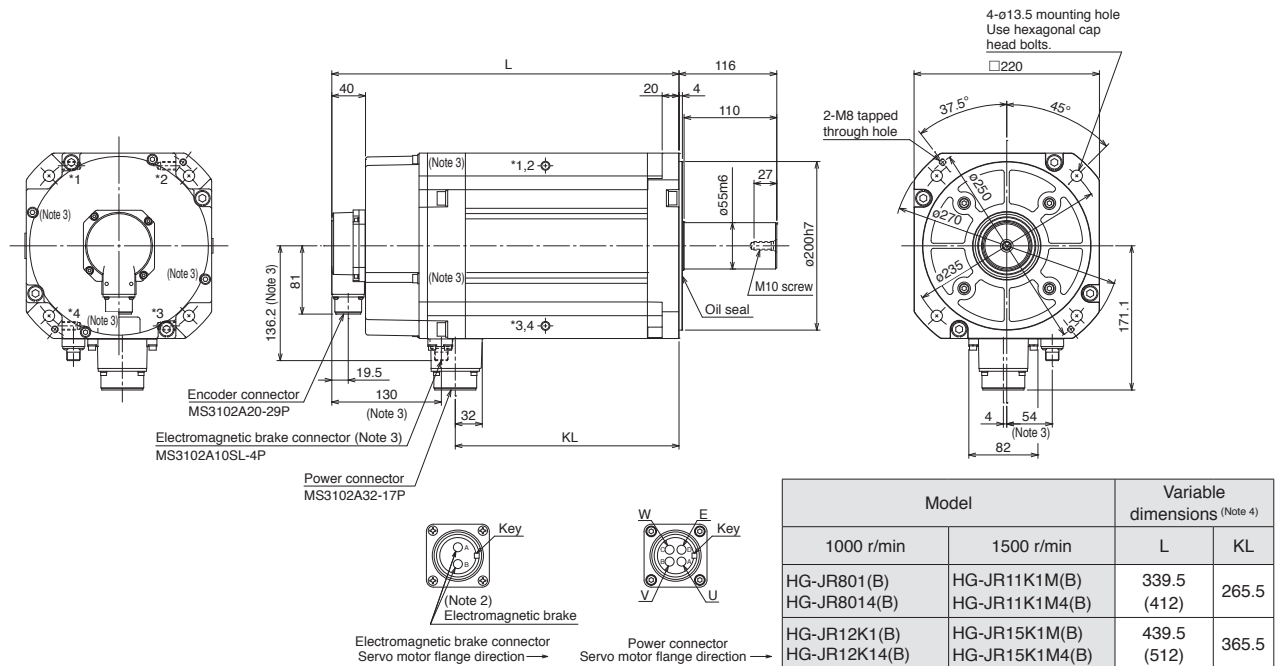

\*1, \*2, \*3, and \*4 are screw holes (M10) for eyebolt.

[Unit: mm]

- Notes:
1. For dimensions without tolerance, general tolerance applies.
  2. The electromagnetic brake terminals do not have polarity.
  3. Only for the models with electromagnetic brake.
  4. Dimensions in brackets are for the models with electromagnetic brake.
  5. Use a friction coupling to fasten a load.

# Rotary Servo Motors

## HG-JR Series Dimensions (Note 1, 2, 6)

●HG-JR15K1, HG-JR20K1, HG-JR25K1, HG-JR15K14, HG-JR20K14, HG-JR25K14

●HG-JR22K1M (Note 7), HG-JR30K1M, HG-JR37K1M, HG-JR22K1M4 (Note 7), HG-JR30K1M4, HG-JR37K1M4

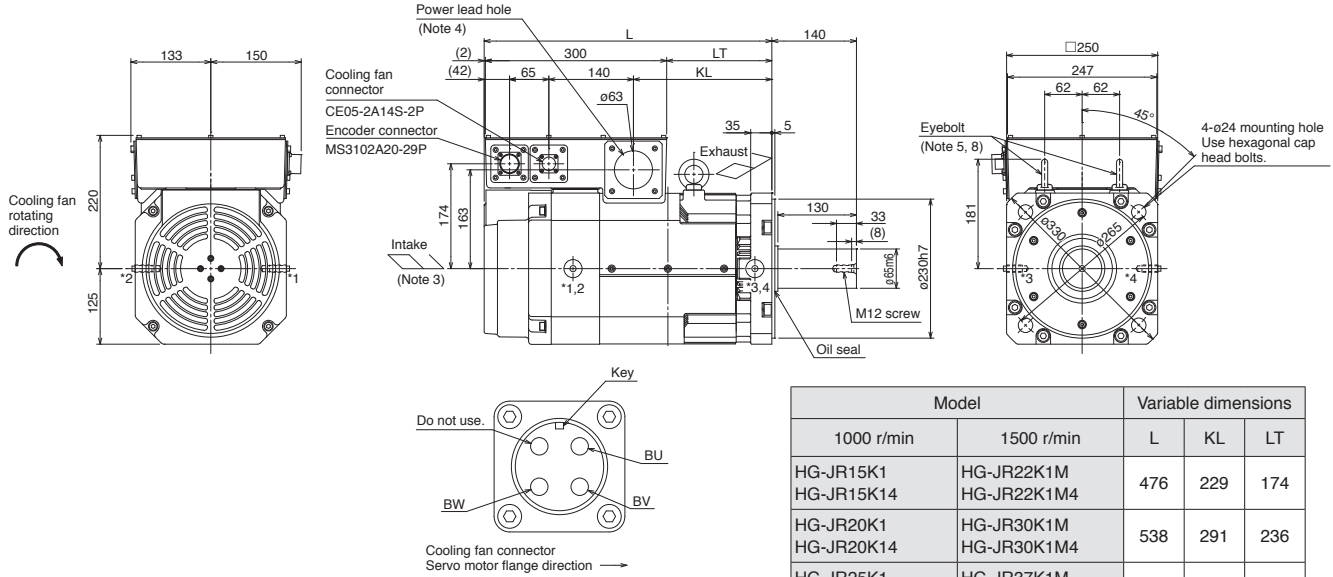

Model		Variable dimensions		
1000 r/min	1500 r/min	L	KL	LT
HG-JR15K1 HG-JR15K14	HG-JR22K1M HG-JR22K1M4	476	229	174
HG-JR20K1 HG-JR20K14	HG-JR30K1M HG-JR30K1M4	538	291	236
HG-JR25K1 HG-JR25K14	HG-JR37K1M HG-JR37K1M4	600	353	298

\*1, \*2, \*3, and \*4 are screw holes (M12) for eyebolt.

[Unit: mm]

●HG-JR30K1, HG-JR37K1, HG-JR30K14, HG-JR37K14

●HG-JR45K1M4, HG-JR55K1M4

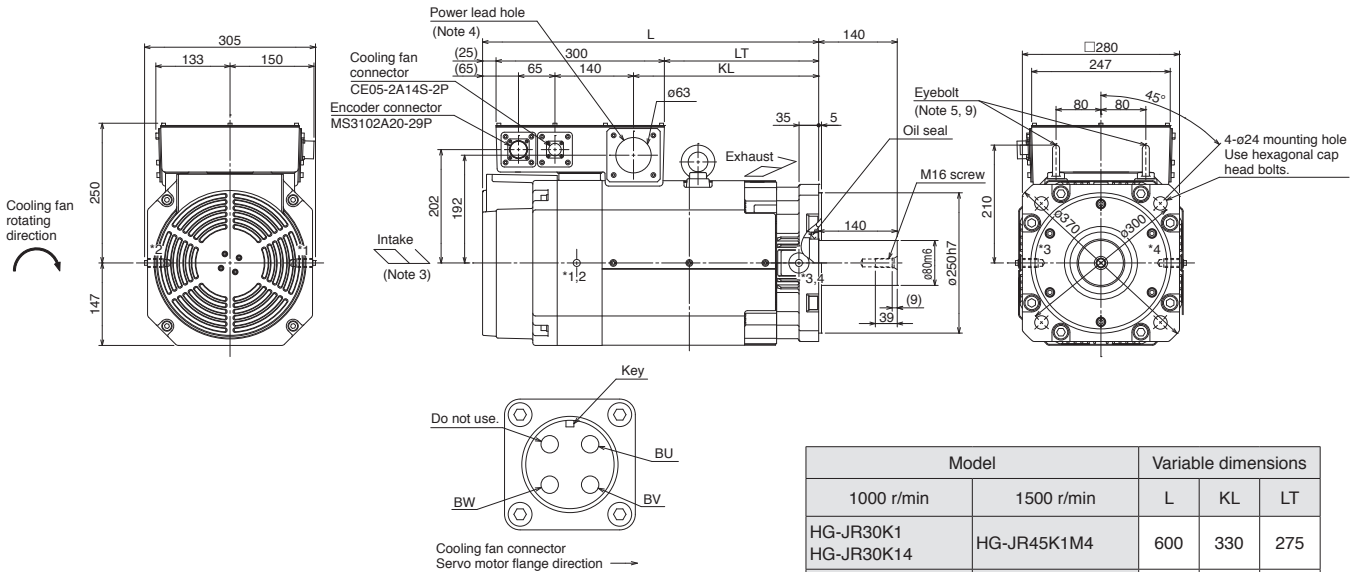

\*1, \*2, \*3, and \*4 are screw holes (M16) for eyebolt.

Model		Variable dimensions		
1000 r/min	1500 r/min	L	KL	LT
HG-JR30K1 HG-JR30K14	HG-JR45K1M4	600	330	275
HG-JR37K1 HG-JR37K14	HG-JR55K1M4	664	394	339

[Unit: mm]

- Notes: 1. For dimensions without tolerance, general tolerance applies.  
 2. Use a friction coupling to fasten a load.  
 3. Leave a clearance of at least 150 mm between the intake side of the servo motor and wall.  
 4. Prevent oil, water, dust, and other foreign matter from entering the servo motor through the lead hole.  
 5. A washer is placed between the eyebolt and the servo motor to adjust the bolt angle.

6. The terminal block in the terminal box consists of M10 screws for the motor power input (U, V, and W).  
 7. HG-JR22K1M/HG-JR22K1M4 have been modified from September 2014 production. Refer to "Servo Motor Instruction Manual (Vol. 3)" for the previous dimensions.  
 8. When using the servo motor without the eyebolt, plug the threaded hole with a bolt of M12 x 20 or shorter.  
 9. When using the servo motor without the eyebolt, plug the threaded hole with a bolt of M16 x 20 or shorter.

**HG-JR Series Dimensions** (Note 1, 2, 6, 7)

●HG-JR110K24W0C

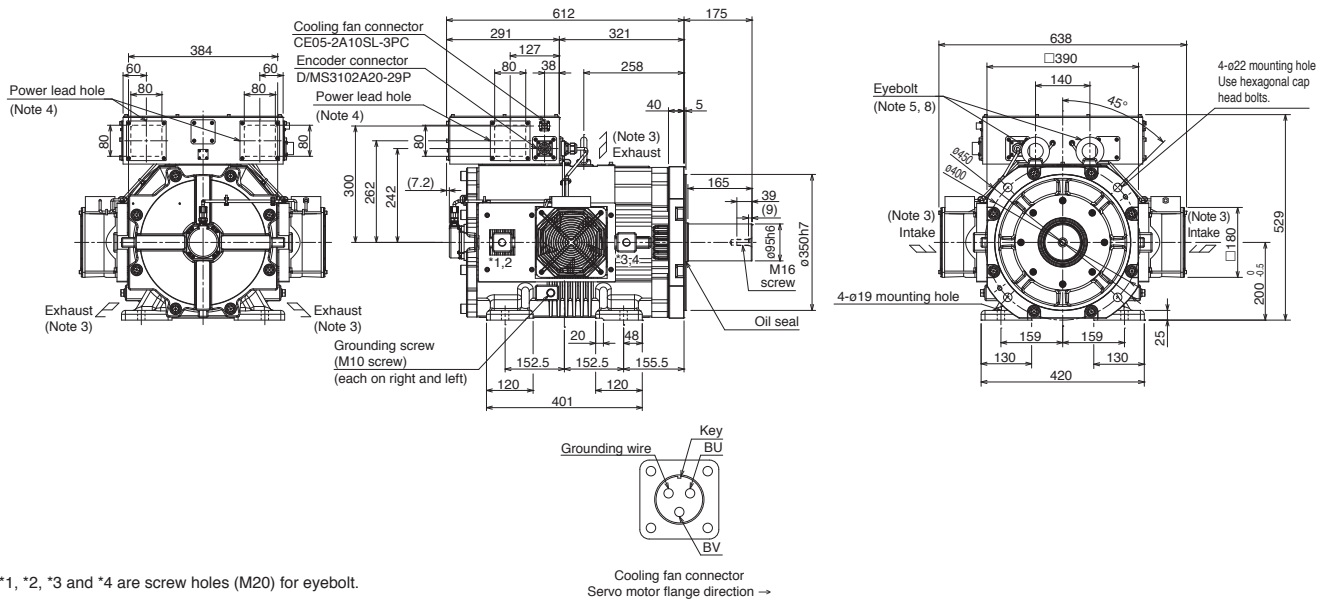

\*1, \*2, \*3 and \*4 are screw holes (M20) for eyebolt.

Cooling fan connector  
Servo motor flange direction →

[Unit: mm]

●HG-JR150K24W0C

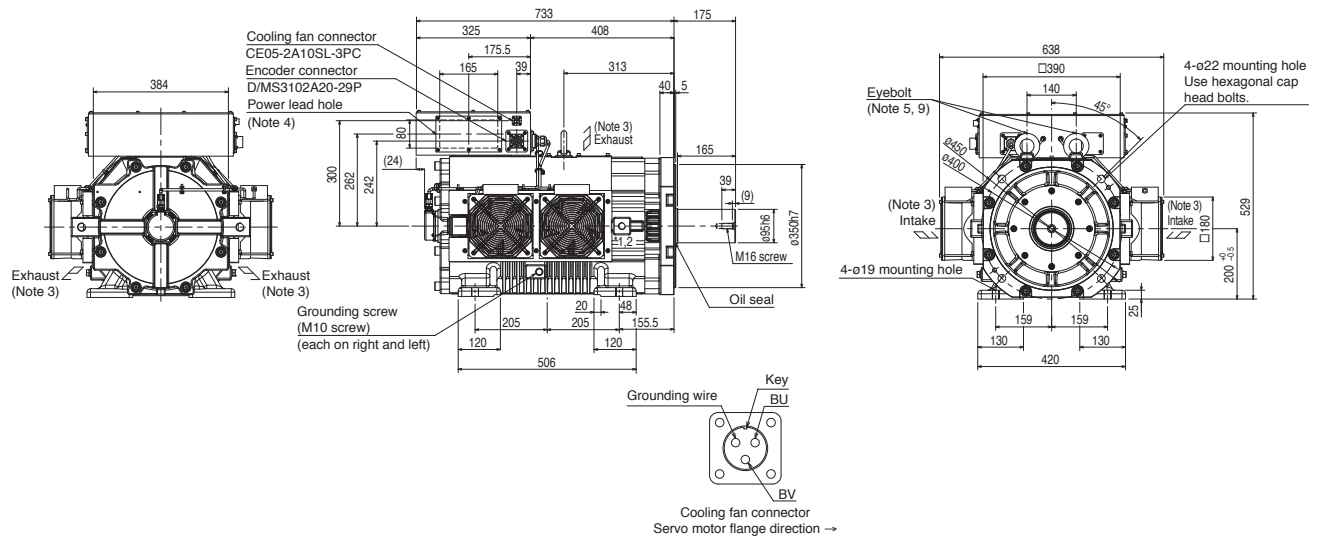

\*1 and \*2 are screw holes (M30) for eyebolt.

Cooling fan connector  
Servo motor flange direction →

[Unit: mm]

Notes: 1. For dimensions without tolerance, general tolerance applies.

2. Use a friction coupling to fasten a load.

3. Leave a clearance of at least 180 mm between the intake/exhaust sides of the servo motor and the wall.

4. Prevent oil, water, dust, and other foreign matter from entering the servo motor through the lead hole.

5. A washer is placed between the eyebolt and the servo motor to adjust the bolt angle.

6. The terminal block in the terminal box consists of M8 screws for the motor power input (U, V, and W).

7. The servo motor must be installed with the shaft end horizontal or downward. Do not install the servo motor with the shaft end upward. When mounting the servo motor with the shaft horizontal, fix the servo motor with the feet, keeping the feet downward. When mounting the servo motor with the shaft vertical, fix the servo motor with the flange and also fix the feet to support the servo motor.

8. When using the servo motor without the eyebolt, plug the threaded hole with a bolt of M20 × 25 or shorter.

9. When using the servo motor without the eyebolt, plug the threaded hole with a bolt of M30 × 45 or shorter.

Servo Amplifiers  
Rotary Servo Motors  
Linear Servo Motors  
Direct Drive Motors  
Options/Peripheral Equipment  
LV5/Wires  
Product List  
Precautions

# Rotary Servo Motors

## HG-JR Series Dimensions (Note 1, 2, 6, 7)

### ●HG-JR180K24W0C, HG-JR200K24W0C

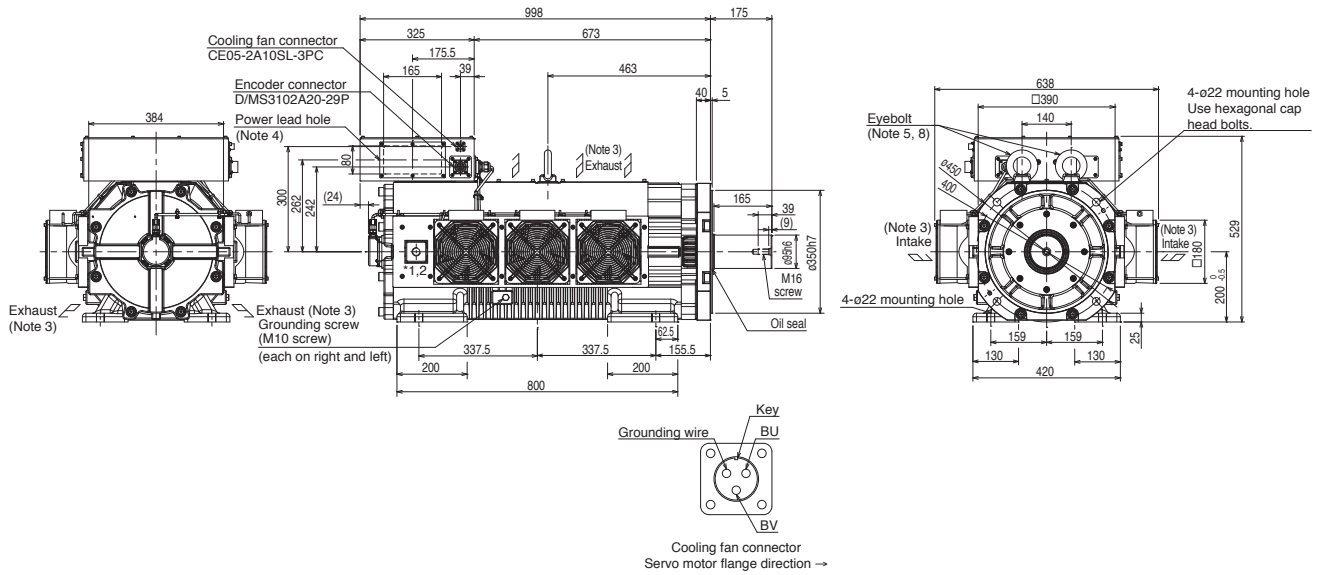

\*1 and \*2 are screw holes (M30) for eyebolt.

[Unit: mm]

### ●HG-JR220K24W0C

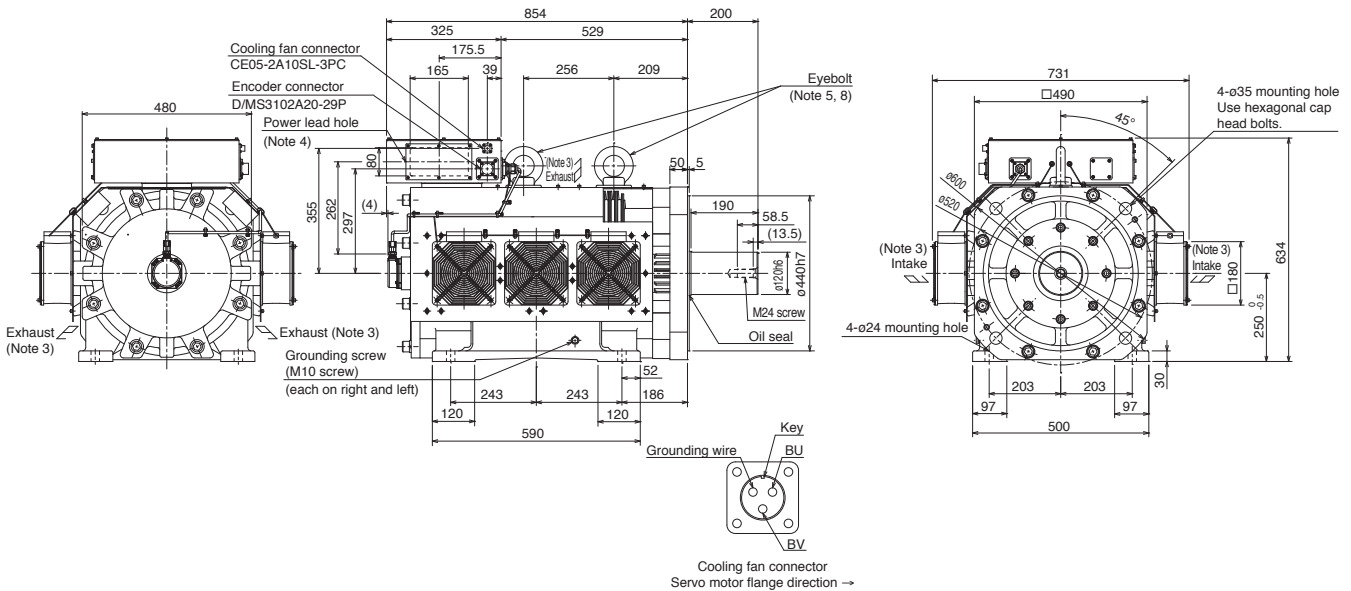

[Unit: mm]

Notes: 1. For dimensions without tolerance, general tolerance applies.

2. Use a friction coupling to fasten a load.

3. Leave a clearance of at least 180 mm between the intake/exhaust sides of the servo motor and the wall.

4. Prevent oil, water, dust, and other foreign matter from entering the servo motor through the lead hole.

5. A washer is placed between the eyebolt and the servo motor to adjust the bolt angle.

6. The terminal block in the terminal box consists of M8 screws for the motor power input (U, V, and W).

7. The servo motor must be installed with the shaft end horizontal or downward. Do not install the servo motor with the shaft end upward. When mounting the servo motor with the shaft horizontal, fix the servo motor with the feet, keeping the feet downward. When mounting the servo motor with the shaft vertical, fix the servo motor with the flange and also fix the feet to support the servo motor.

8. When using the servo motor without the eyebolt, plug the threaded hole with a bolt of M30 x 45 or shorter.

## HG-RR Series Dimensions (Note 1, 5)

### ●HG-RR103(B), HG-RR153(B), HG-RR203(B)

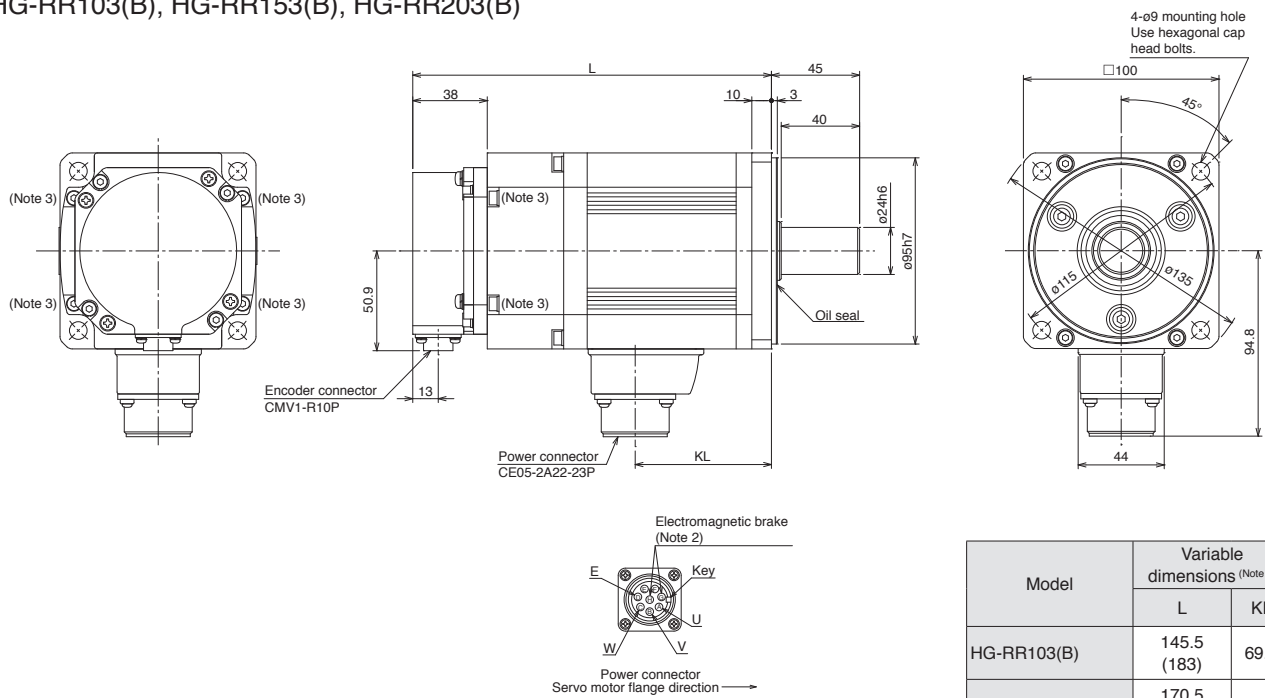

Model	Variable dimensions (Note 4)	
	L	KL
HG-RR103(B)	145.5 (183)	69.5
HG-RR153(B)	170.5 (208)	94.5
HG-RR203(B)	195.5 (233)	119.5

[Unit: mm]

### ●HG-RR353(B), HG-RR503(B)

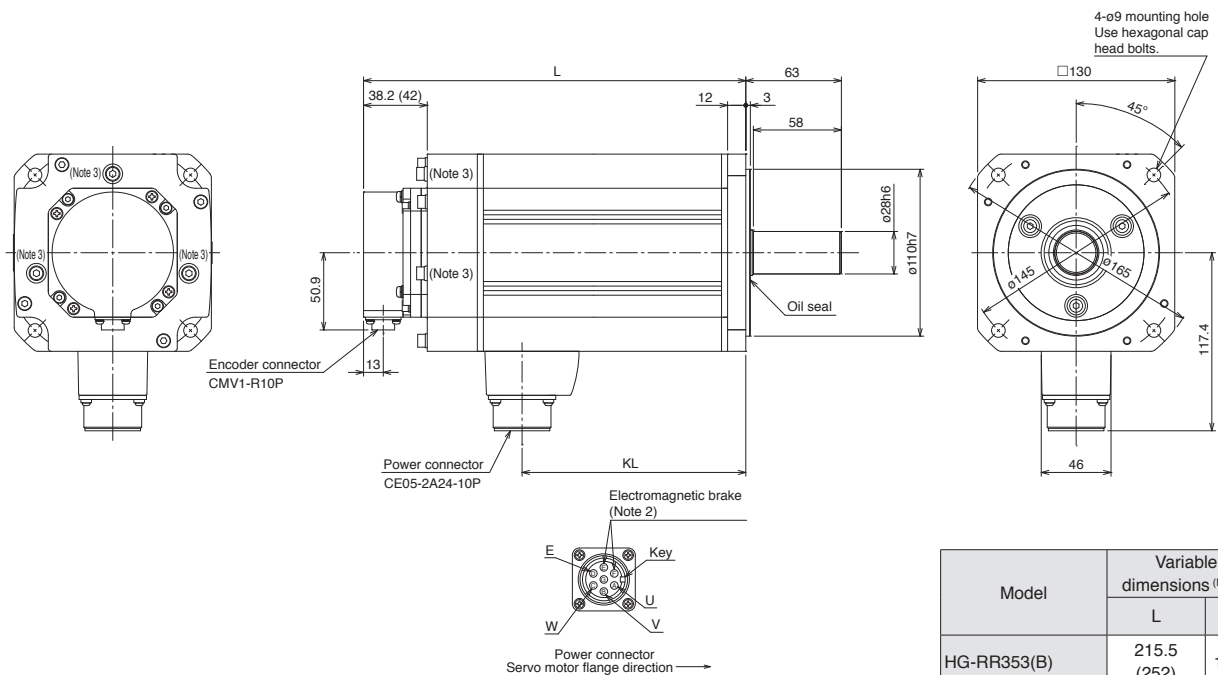

Model	Variable dimensions (Note 4)	
	L	KL
HG-RR353(B)	215.5 (252)	147.5
HG-RR503(B)	272.5 (309)	204.5

[Unit: mm]

- Notes: 1. For dimensions without tolerance, general tolerance applies.  
 2. The electromagnetic brake terminals do not have polarity.  
 3. Only for the models with electromagnetic brake.  
 4. Dimensions in brackets are for the models with electromagnetic brake.  
 5. Use a friction coupling to fasten a load.

# Rotary Servo Motors

## HG-UR Series Dimensions (Note 1, 5)

### ●HG-UR72(B), HG-UR152(B)

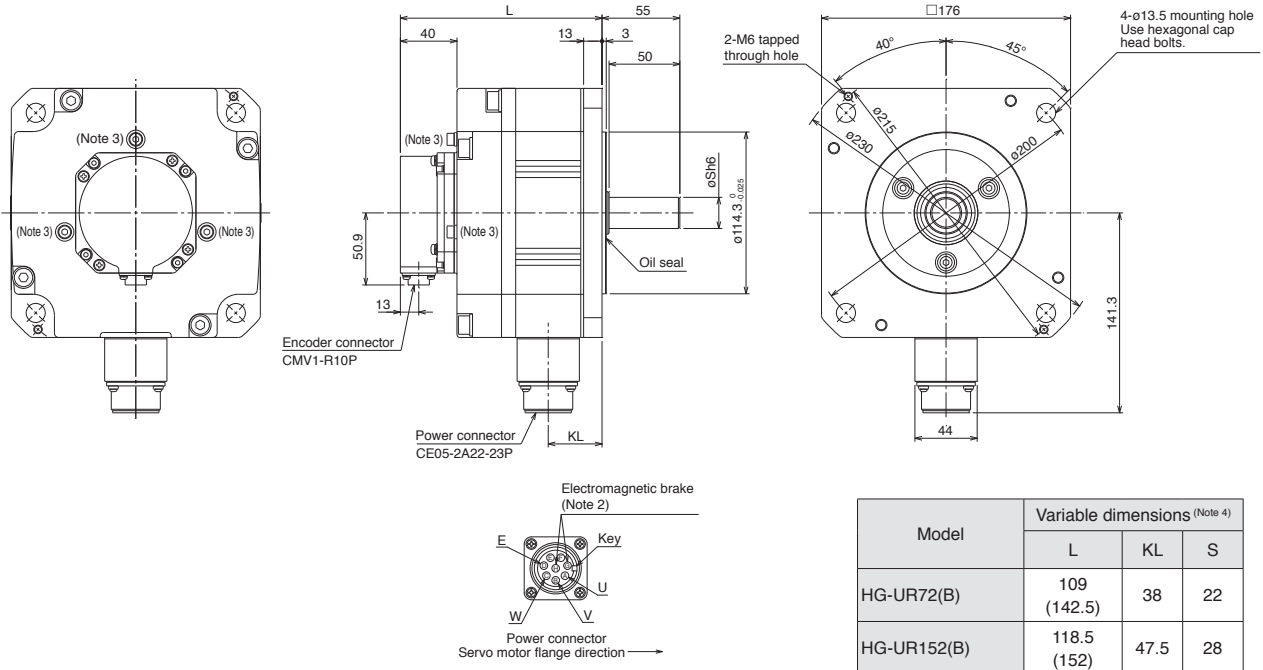

[Unit: mm]

### ●HG-UR202(B), HG-UR352(B), HG-UR502(B)

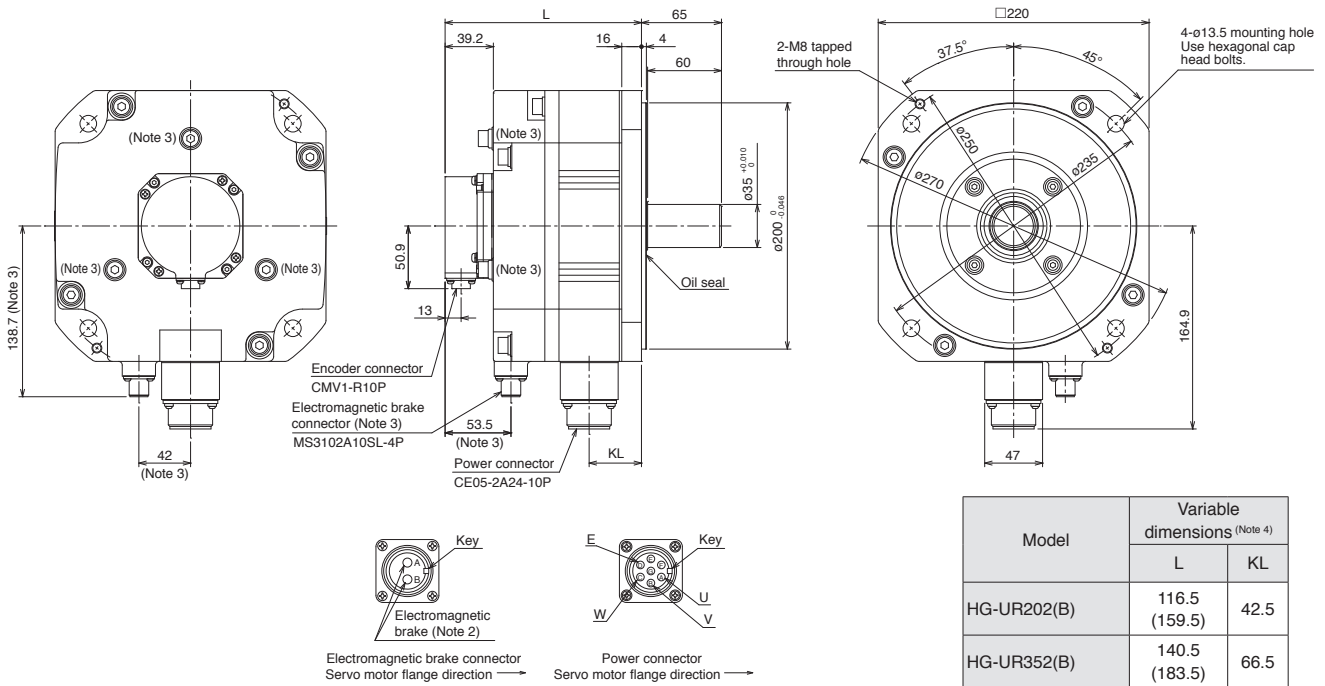

[Unit: mm]

- Notes: 1. For dimensions without tolerance, general tolerance applies.  
 2. The electromagnetic brake terminals do not have polarity.  
 3. Only for the models with electromagnetic brake.  
 4. Dimensions in brackets are for the models with electromagnetic brake.  
 5. Use a friction coupling to fasten a load.



**HG-AK Series Dimensions** (Note 1, 4)

●HG-AK0136(B), HG-AK0236(B), HG-AK0336(B)

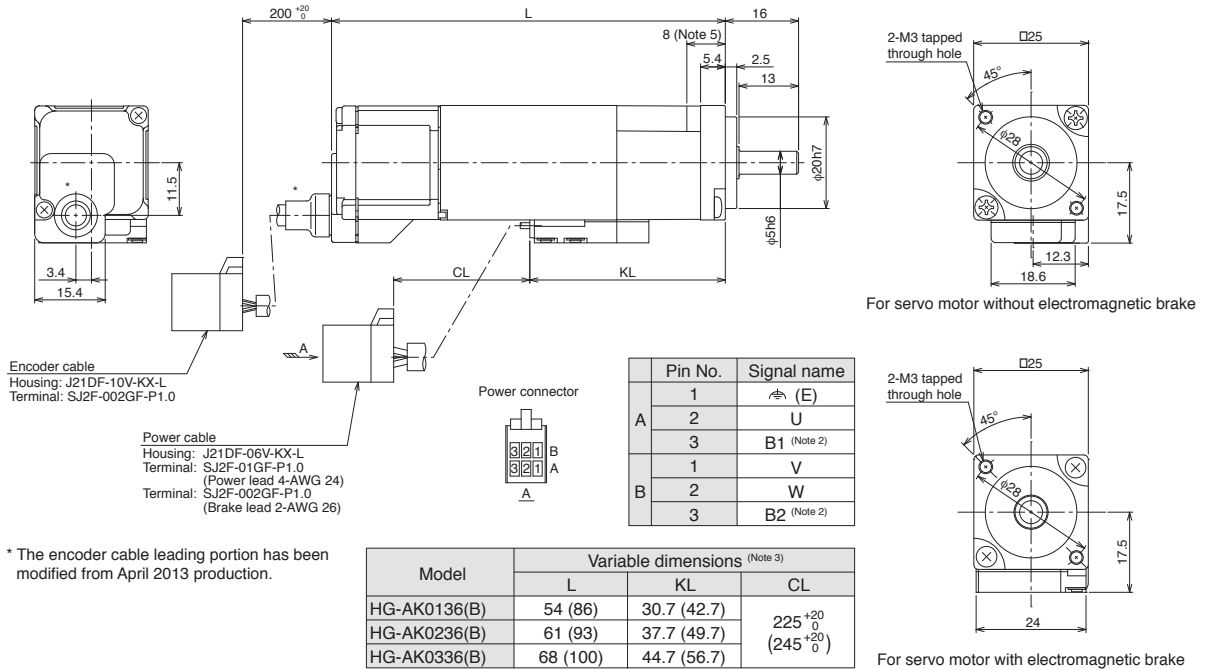

[Unit: mm]

●HG-AK0136(B)-S100, HG-AK0236(B)-S100, HG-AK0336(B)-S100

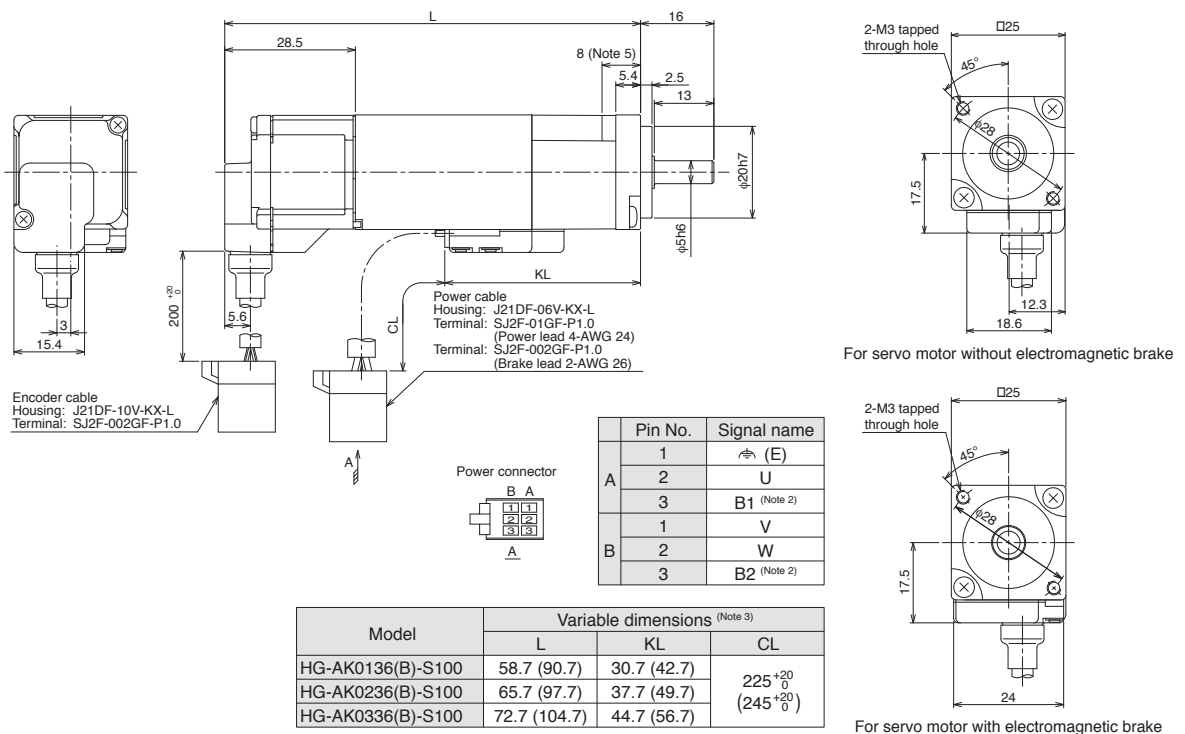

[Unit: mm]

- Notes: 1. For dimensions without tolerance, general tolerance applies.  
 2. The electromagnetic brake terminals (B1, B2) do not have polarity.  
 3. Dimensions in brackets are for the models with electromagnetic brake.  
 4. Use a friction coupling to fasten a load.  
 5. Select a mounting screw whose length is within this dimension.

# Rotary Servo Motors

## HG-KR Series Geared Servo Motor Specifications

With gear reducer for general industrial machines: G1

Model	Output [W]	Reduction ratio	Actual reduction ratio	Moment of inertia J [ $\times 10^{-4}$ kg·m <sup>2</sup> ] (Note 1)		Permissible load to motor inertia ratio (Note 2) (when converted into the servo motor shaft)	Mass [kg]		Lubrication method	Mounting direction
				Standard	With electromagnetic brake		Standard	With electromagnetic brake		
HG-KR053(B)G1	50	1/5	9/44	0.0820	0.0840	5 times or less	1.4	1.6	Grease (filled)	Any direction
		1/12	49/576	0.104	0.106		1.8	2.0		
		1/20	25/484	0.0860	0.0880		1.6	1.8		
HG-KR13(B)G1	100	1/5	9/44	0.115	0.121	5 times or less	2.0	2.2		
		1/12	49/576	0.137	0.143		3.3	3.7		
		1/20	25/484	0.119	0.125		3.9	4.3		
HG-KR23(B)G1	200	1/5	19/96	0.375	0.397	7 times or less	3.7	4.1		
		1/12	961/11664	0.418	0.440		4.3	4.7		
		1/20	513/9984	0.391	0.413		5.4	5.8		
HG-KR43(B)G1	400	1/5	19/96	0.525	0.547	7 times or less	6.0	7.0		
		1/12	961/11664	0.568	0.590		7.1	8.1		
		1/20	7/135	0.881	0.903		10	11		
HG-KR73(B)G1	750	1/5	1/5	1.68	1.79	5 times or less				
		1/12	7/87	2.35	2.46					
		1/20	625/12544	2.41	2.52					

Item	Specifications
Mounting method	Flange mounting
Output shaft rotating direction	Same as the servo motor output shaft direction
Backlash (Note 4)	60 minutes or less at gear reducer output shaft
Maximum torque	Three times of the rated torque (Refer to HG-KR series specifications in this catalog for the rated torque.)
Maximum speed (at servo motor shaft)	4500 r/min (permissible instantaneous speed: 5175 r/min)
IP rating (gear reducer part)	Equivalent to IP44
Gear reducer efficiency (Note 3)	40% to 85%

- Notes: 1. The moments of inertia in the table are the values that are converted into motor shaft of the servo motor with gear reducer (and with electromagnetic brake).  
 2. Contact your local sales office if the load to motor inertia ratio exceeds the value in the table.  
 3. The gear reducer efficiency varies depending on the reduction ratio and also varies with the conditions of use, such as output torque, speed, and temperature. The values in the table represent typical values at the rated torque and speed and at the normal temperature. They are not guaranteed values.  
 4. The backlash can be converted: 1 minute = 0.0167°

**HG-KR Series Geared Servo Motor Dimensions** (Note 1, 5)

With gear reducer for general industrial machines

●HG-KR\_(B)G1

Drawing is schematic only, and the shapes or the mounting screws may differ from those of the actual servo motor. Refer to "Servo Motor Instruction Manual (Vol. 3)" for details.

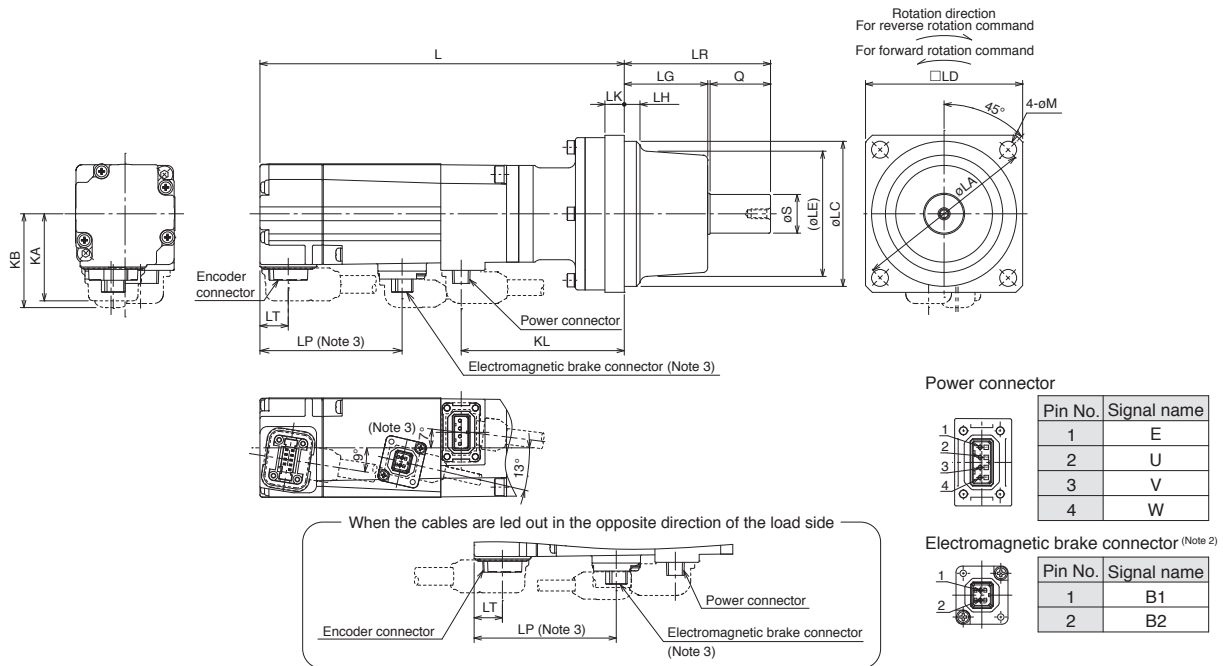

[Unit: mm]

Model	Reduction ratio (Actual reduction ratio)	Variable dimensions (Note 4)																	
		L	LA	LC	LD	LE	S	LH	LK	KL	LG	Q	LR	M	KA	KB	LT	LP	
HG-KR053(B)G1	1/5 (9/44)	110.1 (150.7)	75	60h7	65	51	18h6	6.5	8	67.5	34.5	25	60.5	7	36	37.1 (38.8)	11.7	-	(58.8)
	1/12 (49/576)	128.9 (189.5)								86.3									
	1/20 (25/484)	126.1 (166.7)								83.5									
	1/12 (49/576)	144.9 (185.5)								102.3									
HG-KR13(B)G1	1/5 (9/44)	129.8 (166.6)	100	82h7	90	25h6	8	10	89.6	38	35	74	9	46	47.1 (47.1)	11.8	-	(57.8)	
	1/12 (961/11664)	149.6 (186.4)							109.4										
	1/20 (513/9984)	151.5 (188.3)							111.3										
	1/12 (961/11664)	171.3 (208.1)							131.1										
HG-KR43(B)G1	1/5 (19/96)	177 (217.3)	115	95h7	100	32h6	9.5	10	135.1	39	50	90	14	56	57.1 (57.1)	-	(63.1)		
	1/12 (7/87)	199 (239.3)							134.6										
	1/20 (625/12544)	212 (252.3)							156.6										
	1/12 (7/87)	199 (239.3)							156.6										
HG-KR73(B)G1	1/5 (1/5)	177 (217.3)	140	115h7	120	98	40h6	11.5	15	44.5	60	105.5	14	56	57.1 (57.1)	-	(63.1)		
	1/12 (7/87)	199 (239.3)							134.6										
	1/20 (625/12544)	212 (252.3)							156.6										
	1/12 (7/87)	199 (239.3)							156.6										

- Notes: 1. For dimensions without tolerance, general tolerance applies. The actual dimensions may be 1 mm to 3 mm larger than the dimensions indicated since the outer frame of the gear reducer is made by casting. Make allowance for the actual dimensions in the design of a machine.  
 2. The electromagnetic brake terminals (B1, B2) do not have polarity.  
 3. Only for the models with electromagnetic brake.  
 4. Dimensions in brackets are for the models with electromagnetic brake.  
 5. Use a friction coupling to fasten a load.

# Rotary Servo Motors

## HG-KR Series Geared Servo Motor Specifications

With flange-output type gear reducer for high precision applications, flange mounting: G5

Model	Output [W]	Reduction ratio (Note 3)	Moment of inertia J [ $\times 10^{-4}$ kg·m <sup>2</sup> ] (Note 1)		Permissible load to motor inertia ratio (Note 2) (when converted into the servo motor shaft)	Mass [kg]		Lubrication method	Mounting direction
			Standard	With electromagnetic brake		Standard	With electromagnetic brake		
HG-KR053(B)G5	50	1/5 (40 × 40)	0.0485	0.0507	10 times or less	0.55	0.75	Grease (filled)	Any direction
		1/5 (60 × 60)	0.113	0.115		1.1	1.3		
		1/9	0.0475	0.0497		0.56	0.76		
		1/11	0.105	0.107		1.2	1.4		
		1/21	0.0960	0.0980					
		1/33	0.0900	0.0920					
1/45	0.0900	0.0920							
HG-KR13(B)G5	100	1/5 (40 × 40)	0.0812	0.0872	10 times or less	0.75	0.95		
		1/5 (60 × 60)	0.146	0.152		1.3	1.5		
		1/11	0.138	0.144		1.4	1.6		
		1/21	0.129	0.135					
		1/33	0.140	0.146		2.6	2.8		
		1/45	0.139	0.145					
HG-KR23(B)G5	200	1/5	0.422	0.444	14 times or less	1.8	2.2		
		1/11	0.424	0.446		1.9	2.3		
		1/21	0.719	0.741		3.4	3.8		
		1/33	0.673	0.695					
		1/45	0.672	0.694					
HG-KR43(B)G5	400	1/5	0.572	0.594	14 times or less	2.3	2.7		
		1/11	0.947	0.969		3.9	4.3		
		1/21	0.869	0.891					
		1/33	0.921	0.943		6.0	6.4		
		1/45	0.915	0.937					
HG-KR73(B)G5	750	1/5	1.91	2.02	10 times or less	4.8	5.8		
		1/11	1.82	1.93		5.1	6.1		
		1/21	2.01	2.12		7.2	8.2		
		1/33	1.79	1.90					
		1/45	1.79	1.90					

Item	Specifications
Mounting method	Flange mounting
Output shaft rotating direction	Same as the servo motor output shaft direction
Backlash (Note 5)	3 minutes or less at gear reducer output shaft
Maximum torque	Three times of the rated torque (Refer to HG-KR series specifications in this catalog for the rated torque.)
Maximum speed (at servo motor shaft)	6000 r/min (permissible instantaneous speed: 6900 r/min)
IP rating (gear reducer part)	Equivalent to IP44
Gear reducer efficiency (Note 4)	1/5 (60 × 60): 12%, 1/11, 1/21, 1/33 and 1/45 of HG-KR053(B)G5: 22% to 34% 1/5 (40 × 40) and 1/9 of HG-KR053(B)G5, and HG-KR13(B)G5 to HG-KR73(B)G5: 48% to 84%

- Notes: 1. The moments of inertia in the table are the values that are converted into motor shaft of the servo motor with gear reducer (and with electromagnetic brake).  
2. Contact your local sales office if the load to motor inertia ratio exceeds the value in the table.  
3. The values in brackets represent the dimensions of flange.  
4. The gear reducer efficiency varies depending on the reduction ratio and also varies with the conditions of use, such as output torque, speed, and temperature.  
The values in the table represent typical values at the rated torque and speed and at the normal temperature. They are not guaranteed values.  
5. The backlash can be converted: 1 minute = 0.0167°

**HG-KR Series Geared Servo Motor Dimensions (Note 1)**

With flange-output type gear reducer for high precision applications, flange mounting

●HG-KR\_(B)G5

Drawing is schematic only, and the shapes or the mounting screws may differ from those of the actual servo motor. Refer to "Servo Motor Instruction Manual (Vol. 3)" for details.

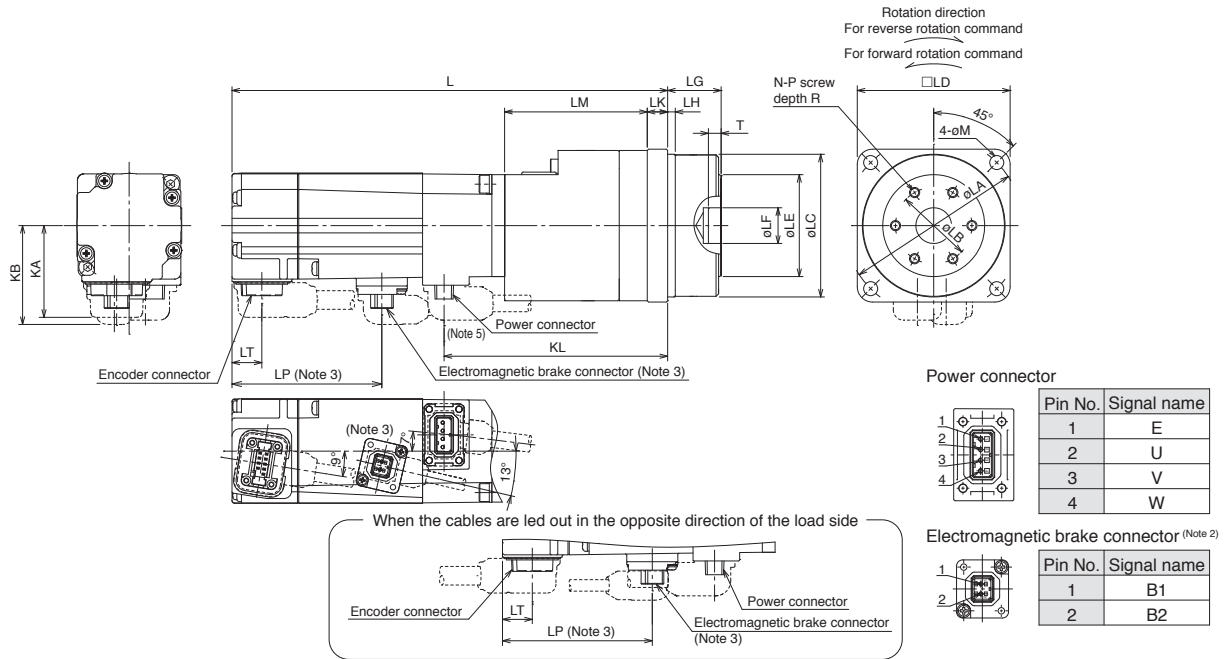

[Unit: mm]

Model	Reduction ratio (Note 6)	Variable dimensions (Note 4)																P	R	M	KA	KB	LT	LP
		L	LA	LB	LC	LD	LE	LF	LG	LH	LK	LM	KL	T	N									
HG-KR053(B)G5	1/5 (40 × 40)	105.9 (146.5)	46	18	40h7	40	24	5H7	15 <sup>+0.25</sup> <sub>-0.20</sub>	2.5	5	34.5	63.3	3	3	M4	6	3.4	36	37.1 (38.8)	11.7	-	(58.8)	
	1/5 (60 × 60) (Note 5)	130.4 (171)	70	30	56h7	60	40	14H7	21 <sup>+0.4</sup> <sub>-0.5</sub>	3	8	56	87.8	5	6		7	5.5						
	1/9	105.9 (146.5)	46	18	40h7	40	24	5H7	15 <sup>+0.25</sup> <sub>-0.20</sub>	2.5	5	34.5	63.3	3	3		6	3.4						
	1/11 (Note 5)	130.4 (171)	70	30	56h7	60	40	14H7	21 <sup>+0.4</sup> <sub>-0.5</sub>	3	8	56	87.8	5	6		7	5.5						
	1/21 (Note 5)																7	5.5						
HG-KR13(B)G5	1/5 (40 × 40)	121.9 (162.5)	46	18	40h7	40	24	5H7	15 <sup>+0.25</sup> <sub>-0.20</sub>	2.5	5	34.5	79.3	3	3	M6	6	3.4	36	37.1 (38.8)	11.7	-	(58.8)	
	1/5 (60 × 60) (Note 5)	146.4 (187)	70	30	56h7	60	40	14H7	21 <sup>+0.4</sup> <sub>-0.5</sub>	3	8	56	103.8	5	6		7	5.5						
	1/11 (Note 5)	146.4 (187)	70	30	56h7	60	40	14H7	21 <sup>+0.4</sup> <sub>-0.5</sub>	3	8	56	103.8	5	6		7	5.5						
	1/21 (Note 5)																7	5.5						
	HG-KR23(B)G5	1/5 (40 × 40)	140.6 (177.4)	70	30	56h7	60	40	14H7	21 <sup>+0.4</sup> <sub>-0.5</sub>	3	8	56	100.4	5		6	M4						6
1/5 (60 × 60) (Note 5)		146.4 (187)	70	30	56h7	60	40	14H7	21 <sup>+0.4</sup> <sub>-0.5</sub>	3	8	56	103.8	5	6	7	5.5							
1/11 (Note 5)		146.4 (187)	70	30	56h7	60	40	14H7	21 <sup>+0.4</sup> <sub>-0.5</sub>	3	8	56	103.8	5	6	7	5.5							
1/21 (Note 5)																7	5.5							
HG-KR43(B)G5		1/5 (40 × 40)	162.3 (199.1)	70	30	56h7	60	40	14H7	21 <sup>+0.4</sup> <sub>-0.5</sub>	3	8	56	122.1	5	6	M4		6	3.4	36	37.1 (38.8)	11.7	-
	1/5 (60 × 60) (Note 5)	169.3 (206.1)	105	45	85h7	90	59	24H7	27 <sup>+0.4</sup> <sub>-0.5</sub>	8	10	61	129.1	5	6	7		5.5						
	1/11 (Note 5)	169.3 (206.1)	105	45	85h7	90	59	24H7	27 <sup>+0.4</sup> <sub>-0.5</sub>	8	10	61	129.1	5	6	7		5.5						
	1/21 (Note 5)															7		5.5						
	HG-KR73(B)G5	1/5 (40 × 40)	181.3 (218.1)	135	60	115h7	120	84	32H7	35 <sup>+0.4</sup> <sub>-0.5</sub>	13	13	70	141.1	5	6		M8	6	3.4				
1/5 (60 × 60) (Note 5)		190 (230.3)	105	45	85h7	90	59	24H7	27 <sup>+0.4</sup> <sub>-0.5</sub>	8	10	68	147.6	5	6	7	5.5							
1/11 (Note 5)		190 (230.3)	105	45	85h7	90	59	24H7	27 <sup>+0.4</sup> <sub>-0.5</sub>	8	10	68	147.6	5	6	7	5.5							
1/21 (Note 5)																7	5.5							
HG-KR053(B)G5		1/5 (40 × 40)	105.9 (146.5)	46	18	40h7	40	24	5H7	15 <sup>+0.25</sup> <sub>-0.20</sub>	2.5	5	34.5	63.3	3	3	M4		6	3.4	36	37.1 (38.8)	11.7	-
	1/5 (60 × 60) (Note 5)	130.4 (171)	70	30	56h7	60	40	14H7	21 <sup>+0.4</sup> <sub>-0.5</sub>	3	8	56	87.8	5	6	7		5.5						
	1/9	105.9 (146.5)	46	18	40h7	40	24	5H7	15 <sup>+0.25</sup> <sub>-0.20</sub>	2.5	5	34.5	63.3	3	3	6		3.4						
	1/11 (Note 5)	130.4 (171)	70	30	56h7	60	40	14H7	21 <sup>+0.4</sup> <sub>-0.5</sub>	3	8	56	87.8	5	6	7		5.5						
	1/21 (Note 5)															7		5.5						

- Notes: 1. For dimensions without tolerance, general tolerance applies. The actual dimensions may be 1 mm to 3 mm larger than the dimensions indicated since the outer frame of the gear reducer is made by casting. Make allowance for the actual dimensions in the design of a machine.  
 2. The electromagnetic brake terminals (B1, B2) do not have polarity.  
 3. Only for the models with electromagnetic brake.  
 4. Dimensions in brackets are for the models with electromagnetic brake.  
 5. Lead out the power cable in opposite direction of the motor shaft.  
 6. The values in brackets represent the dimensions of flange.

# Rotary Servo Motors

## HG-KR Series Geared Servo Motor Specifications

With shaft-output type gear reducer for high precision applications, flange mounting: G7

Model	Output [W]	Reduction ratio (Note 3)	Moment of inertia J [ $\times 10^{-4}$ kg·m <sup>2</sup> ] (Note 1)		Permissible load to motor inertia ratio (Note 2) (when converted into the servo motor shaft)	Mass [kg]		Lubrication method	Mounting direction
			Standard	With electromagnetic brake		Standard	With electromagnetic brake		
HG-KR053(B)G7	50	1/5 (40 × 40)	0.0512	0.0534	10 times or less	0.58	0.78	Grease (filled)	Any direction
		1/5 (60 × 60)	0.119	0.121		1.2	1.4		
		1/9	0.0492	0.0514		0.58	0.78		
		1/11	0.106	0.108		1.3	1.5		
		1/21	0.0960	0.0980					
		1/33	0.0900	0.0920					
1/45	0.0900	0.0920							
HG-KR13(B)G7	100	1/5 (40 × 40)	0.0839	0.0899	10 times or less	0.78	0.98		
		1/5 (60 × 60)	0.152	0.158		1.4	1.6		
		1/11	0.139	0.145		1.5	1.7		
		1/21	0.129	0.135					
		1/33	0.141	0.147		3.0	3.2		
		1/45	0.139	0.145					
1/5	0.428	0.450	14 times or less	3.8	4.2				
1/11	0.424	0.446							
1/21	0.721	0.743							
1/33	0.674	0.696							
1/45	0.672	0.694							
1/5	0.578	0.600				14 times or less	2.4	2.8	
1/11	0.955	0.977							
1/21	0.871	0.893							
1/33	0.927	0.949							
1/45	0.918	0.940							
1/5	1.95	2.06	10 times or less	5.2	6.2				
1/11	1.83	1.94							
1/21	2.03	2.14							
1/33	1.80	1.91							
1/45	1.79	1.90							
							8.6	9.6	

Item	Specifications
Mounting method	Flange mounting
Output shaft rotating direction	Same as the servo motor output shaft direction
Backlash (Note 5)	3 minutes or less at gear reducer output shaft
Maximum torque	Three times of the rated torque (Refer to HG-KR series specifications in this catalog for the rated torque.)
Maximum speed (at servo motor shaft)	6000 r/min (permissible instantaneous speed: 6900 r/min)
IP rating (gear reducer part)	Equivalent to IP44
Gear reducer efficiency (Note 4)	1/5 (60 × 60): 12%, 1/11, 1/21, 1/33 and 1/45 of HG-KR053(B)G7: 22% to 34% 1/5 (40 × 40) and 1/9 of HG-KR053(B)G7, and HG-KR13(B)G7 to HG-KR73(B)G7: 48% to 84%

- Notes: 1. The moments of inertia in the table are the values that are converted into motor shaft of the servo motor with gear reducer (and with electromagnetic brake).  
 2. Contact your local sales office if the load to motor inertia ratio exceeds the value in the table.  
 3. The values in brackets represent the dimensions of flange.  
 4. The gear reducer efficiency varies depending on the reduction ratio and also varies with the conditions of use, such as output torque, speed, and temperature.  
 The values in the table represent typical values at the rated torque and speed and at the normal temperature. They are not guaranteed values.  
 5. The backlash can be converted: 1 minute = 0.0167°

**HG-KR Series Geared Servo Motor Dimensions** (Note 1, 5, 8)

With shaft-output type gear reducer for high precision applications, flange mounting

●HG-KR\_(B)G7

Drawing is schematic only, and the shapes or the mounting screws may differ from those of the actual servo motor. Refer to "Servo Motor Instruction Manual (Vol. 3)" for details.

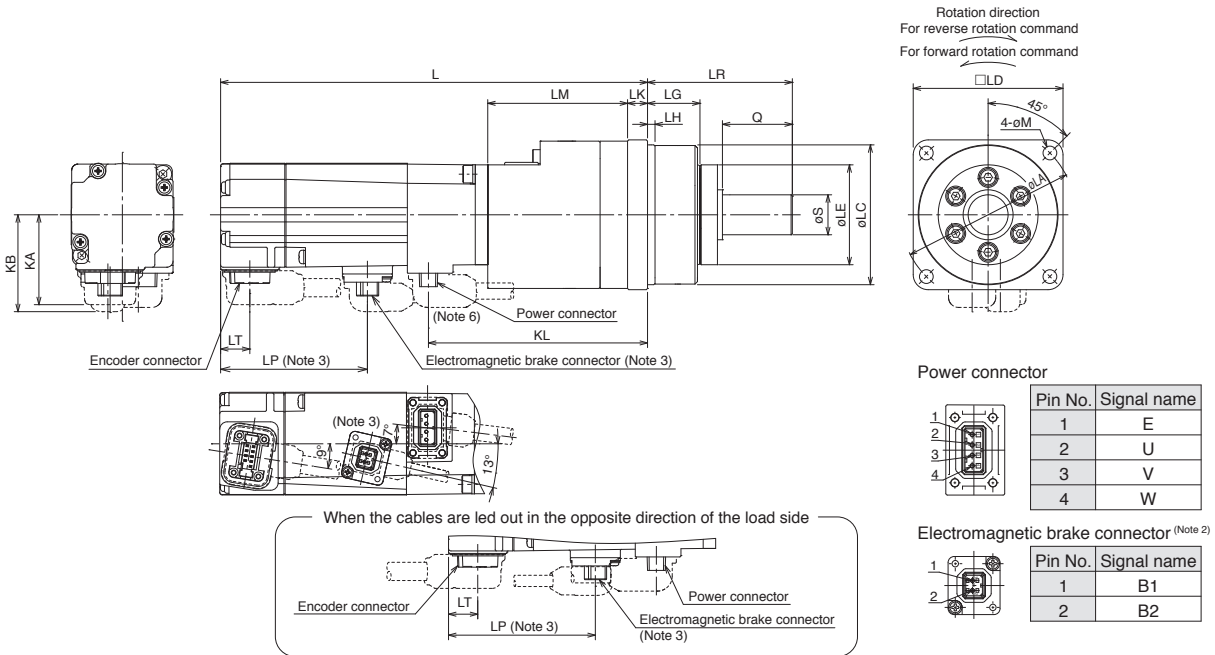

[Unit: mm]

Model	Reduction ratio (Note 7)	Variable dimensions (Note 4)														KA	KB	LT	LP
		L	LA	LC	LD	LE	S	LG	LH	Q	LR	LK	LM	KL	M				
HG-KR053(B)G7	1/5 (40 × 40)	105.9 (146.5)	46	40h7	40	29	10h7	15	2.5	20	42	5	34.5	63.3	3.4	36	37.1 (38.8)	11.7	-
	1/5 (60 × 60) (Note 6)	130.4 (171)	70	56h7	60	40	16h7	21	3	28	58	8	56	87.8	5.5				
	1/9	105.9 (146.5)	46	40h7	40	29	10h7	15	2.5	20	42	5	34.5	63.3	3.4				
	1/11 (Note 6)																		
	1/21 (Note 6)	130.4 (171)	70	56h7	60	40	16h7	21	3	28	58	8	56	87.8	5.5				
	1/33 (Note 6)																		
HG-KR13(B)G7	1/5 (40 × 40)	121.9 (162.5)	46	40h7	40	29	10h7	15	2.5	20	42	5	34.5	79.3	3.4	36	37.1 (38.8)	11.7	-
	1/5 (60 × 60) (Note 6)	146.4 (187)	70	56h7	60	40	16h7	21	3	28	58	8	56	103.8	5.5				
	1/11 (Note 6)																		
	1/21 (Note 6)	148.9 (189.5)	105	85h7	90	59	25h7	27	8	42	80	10	61	107.4	9				
	1/33 (Note 6)																		
HG-KR23(B)G7	1/5	140.6 (177.4)	70	56h7	60	40	16h7	21	3	28	58	8	56	100.4	5.5	46	47.1 (47.1)	11.8	-
	1/11 (Note 6)																		
	1/21 (Note 6)	147.6 (184.4)	105	85h7	90	59	25h7	27	8	42	80	10	61	107.4	9				
	1/33 (Note 6)																		
HG-KR43(B)G7	1/5	162.3 (199.1)	70	56h7	60	40	16h7	21	3	28	58	8	56	122.1	5.5	46	47.1 (47.1)	11.8	-
	1/11 (Note 6)																		
	1/21 (Note 6)	169.3 (206.1)	105	85h7	90	59	25h7	27	8	42	80	10	61	129.1	9				
	1/33 (Note 6)																		
HG-KR73(B)G7	1/5	190 (230.3)	105	85h7	90	59	25h7	27	8	42	80	10	68	147.6	9	56	57.1 (57.1)	-	(63.1)
	1/11 (Note 6)																		
	1/21 (Note 6)	200 (240.3)	135	115h7	120	84	40h7	35	13	82	133	13	75	157.6	11				
	1/33 (Note 6)																		

- Notes: 1. For dimensions without tolerance, general tolerance applies. The actual dimensions may be 1 mm to 3 mm larger than the dimensions indicated since the outer frame of the gear reducer is made by casting. Make allowance for the actual dimensions in the design of a machine.  
 2. The electromagnetic brake terminals (B1, B2) do not have polarity.  
 3. Only for the models with electromagnetic brake.  
 4. Dimensions in brackets are for the models with electromagnetic brake.  
 5. Use a friction coupling to fasten a load.  
 6. Lead out the power cable in opposite direction of the motor shaft.  
 7. The values in brackets represent the dimensions of flange.  
 8. HG-KR\_(B)G7K is also available for key shaft motor (with key). Refer to the following page for the shaft-end shape.

Servo Amplifiers  
 Rotary Servo Motors  
 Linear Servo Motors  
 Direct Drive Motors  
 Options/Peripheral Equipment  
 LVS/Wires  
 Product List  
 Precautions

# Rotary Servo Motors

## HG-KR Series Geared Servo Motor Special Shaft End Specifications

Standard HG-KR\_(B)G1 (with gear reducer for general industrial machines) has a straight shaft. Key shaft (with key) is also available as a special specification. Contact your local sales office for more details.

Standard HG-KR\_(B)G7 (with shaft-output type gear reducer for high precision applications, flange mounting) has a straight shaft.

HG-KR\_(B)G7K is also available for key shaft motor (with key). Refer to the following for the shaft-end shape.

Key shaft (with key) (Note 1, 2, 3)

Model	Reduction ratio (Note 4)	Variable dimensions						
		S	Q	W	QK	U	T	Y
HG-KR053(B)G7K	1/5 (40 × 40)	10	20	4	15	2.5	4	M3 screw Depth: 6
	1/5 (60 × 60)	16	28	5	25	3	5	M4 screw Depth: 8
	1/9	10	20	4	15	2.5	4	M3 screw Depth: 6
	1/11	16	28	5	25	3	5	M4 screw Depth: 8
	1/21							
	1/33							
1/45								
HG-KR13(B)G7K	1/5 (40 × 40)	10	20	4	15	2.5	4	M3 screw Depth: 6
	1/5 (60 × 60)	16	28	5	25	3	5	M4 screw Depth: 8
	1/11	25	42	8	36	4	7	M6 screw Depth: 12
	1/21							
	1/33							
1/45								
HG-KR23(B)G7K	1/5	16	28	5	25	3	5	M4 screw Depth: 8
	1/11	25	42	8	36	4	7	M6 screw Depth: 12
	1/21							
	1/33							
1/45								
HG-KR43(B)G7K	1/5	16	28	5	25	3	5	M4 screw Depth: 8
	1/11	25	42	8	36	4	7	M6 screw Depth: 12
	1/21							
	1/33							
1/45								
HG-KR73(B)G7K	1/5	25	42	8	36	4	7	M6 screw Depth: 12
	1/11	40	82	12	70	5	8	M10 screw Depth: 20
	1/21							
	1/33							
1/45								

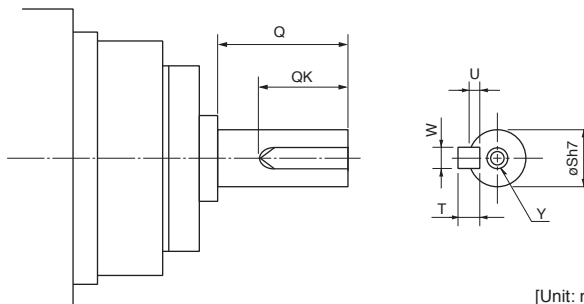

[Unit: mm]

- Notes: 1. Do not use servo motors with key shafts for frequent start/stop applications as this may cause damage to the shaft.  
 2. A single pointed key is attached.  
 3. The dimensions not mentioned in the drawings are the same as those of the straight shaft. Refer to HG-KR\_(B)G7 dimensions in this catalog.  
 4. The values in brackets represent the dimensions of flange.



**HG-SR Series Geared Servo Motor Specifications**

With gear reducer for general industrial machines, flange mounting: G1

Model	Output [kW]	Reduction ratio	Moment of inertia J [x 10 <sup>-4</sup> kg·m <sup>2</sup> ] (Note 1)		Permissible load to motor inertia ratio (Note 2) (when converted into the servo motor shaft)	Mass [kg]		Lubrication method (Note 5)	Mounting direction
			Standard	With electromagnetic brake		Standard	With electromagnetic brake		
HG-SR52(B)G1 HG-SR524(B)G1	0.5	1/6	8.08	10.3	4 times or less	18	20	Grease (filled)	Any direction
		1/11	7.65	9.85					
		1/17	7.53	9.73					
		1/29	7.47	9.67		27	29		
		1/35	8.26	10.5					
		1/43	8.22	10.4					
HG-SR102(B)G1 HG-SR1024(B)G1	1.0	1/6	14.8	17.0	4 times or less	30	32	Grease (filled)	Any direction
		1/11	13.3	15.5					
		1/17	12.9	15.1					
		1/29	12.6	14.8		49	51		
		1/35	12.6	14.8					
		1/43	13.8	16.0					
HG-SR152(B)G1 HG-SR1524(B)G1	1.5	1/6	19.2	21.4	4 times or less	31	33	Grease (filled)	Any direction
		1/11	17.7	19.9					
		1/17	17.3	19.5					
		1/29	18.4	20.6		50	52		
		1/35	18.3	20.5					
		1/43	23.6	25.8					
HG-SR202(B)G1 HG-SR2024(B)G1	2.0	1/6	50.0	59.4	4 times or less	36	42	Grease (filled)	Any direction
		1/11	48.4	57.8					
		1/17	48.1	57.5					
		1/29	54.8	64.2		87	93		
		1/35	54.5	63.9					
		1/43	54.3	63.7					
HG-SR352(B)G1 HG-SR3524(B)G1	3.5	1/6	87.1	96.5	4 times or less	60	66	Oil (Note 3)	Shaft horizontal (Note 4)
		1/11	82.8	92.2					
		1/17	81.5	90.9					
		1/29	86.6	96.0		92	98		
		1/35	86.3	95.7					
		1/43	105	114					
HG-SR502(B)G1 HG-SR5024(B)G1	5.0	1/6	126	135	4 times or less	96	102	Oil (Note 3)	Shaft horizontal (Note 4)
		1/11	114	123					
		1/17	110	119					
		1/29	141	150		165	171		
		1/35	140	150					
		1/43	139	149					
HG-SR702(B)G1 HG-SR7024(B)G1	7.0	1/6	177	187	4 times or less	103	109	Oil (Note 3)	Shaft horizontal (Note 4)
		1/11	190	199					
		1/17	182	192					
		1/29	192	202		172	178		
		1/35	192	201					
		1/43	267	277					
		1/59	266	275		240	246		

- Notes: 1. The moments of inertia in the table are the values that are converted into motor shaft of the servo motor with gear reducer (and with electromagnetic brake).  
 2. Contact your local sales office if the load to motor inertia ratio exceeds the value in the table.  
 3. For applications where the servo motor moves, order a grease lubricated servo motor (special specification) instead of the oil lubricated. Note that the maximum speed of the grease lubricated servo motor is the same as that of the oil lubricated.  
 4. Do not mount the servo motor in a way that the servo motor is tilted to the shaft direction or to the shaft rotation direction. Refer to the asterisk 1 of "Annotations for Geared Servo Motor Specifications" on p. 2-70 in this catalog. Note that servo motors with special specifications may be available to be mounted with other than the shaft horizontal.  
 Refer to "Servo Motor Instruction Manual (Vol. 3)" for the available models.  
 5. The lubricant oil is removed from the gear reducer before shipment, and thus please purchase the required lubricant oil and fill the oil into the gear reducer.

Servo Amplifiers  
 Rotary Servo Motors  
 Linear Servo Motors  
 Direct Drive Motors  
 Options/Peripheral Equipment  
 LV/S/Wires  
 Product List  
 Precautions

# Rotary Servo Motors

## HG-SR Series Geared Servo Motor Specifications

With gear reducer for general industrial machines, flange mounting: G1

Item	Specifications
Mounting method	Flange mounting
Output shaft rotating direction	Opposite from the servo motor output shaft direction
Backlash <sup>(Note 3)</sup>	40 minutes to 2° at gear reducer output shaft <sup>(Note 2)</sup>
Maximum torque	Three times of the rated torque (Refer to HG-SR 2000 r/min series specifications in this catalog for the rated torque.)
Maximum speed (at servo motor shaft)	For grease lubrication: 3000 r/min (permissible instantaneous speed: 3450 r/min) For oil lubrication: 2000 r/min (permissible instantaneous speed: 2300 r/min)
IP rating (gear reducer part)	Equivalent to IP44
Gear reducer efficiency <sup>(Note 1)</sup>	85% to 94%

Notes: 1. The gear reducer efficiency varies depending on the reduction ratio and also varies with the conditions of use, such as output torque, speed, and temperature.

The values in the table represent typical values at the rated torque and speed and at the normal temperature. They are not guaranteed values.

2. This is a designed value, not guaranteed value.

3. The backlash can be converted: 1 minute = 0.0167°



# Rotary Servo Motors

## HG-SR Series Geared Servo Motor Specifications

With gear reducer for general industrial machines, foot mounting: G1H

Model	Output [kW]	Reduction ratio	Moment of inertia J [ $\times 10^{-4} \text{ kg}\cdot\text{m}^2$ ] (Note 1)		Permissible load to motor inertia ratio (Note 2) (when converted into the servo motor shaft)	Mass [kg]		Lubrication method (Note 5)	Mounting direction
			Standard	With electromagnetic brake		Standard	With electromagnetic brake		
HG-SR52(B)G1H HG-SR524(B)G1H	0.5	1/6	8.08	10.3	4 times or less	20	22	Grease (filled)	Any direction
		1/11	7.65	9.85					
		1/17	7.53	9.73					
		1/29	7.47	9.67		28	30		
		1/35	8.26	10.5					
		1/43	8.22	10.4					
HG-SR102(B)G1H HG-SR1024(B)G1H	1.0	1/6	14.8	17.0	4 times or less	31	33	Grease (filled)	Any direction
		1/11	13.3	15.5					
		1/17	12.9	15.1					
		1/29	12.6	14.8		50	52		
		1/35	12.6	14.8					
		1/43	13.8	16.0					
HG-SR152(B)G1H HG-SR1524(B)G1H	1.5	1/6	19.2	21.4	4 times or less	32	34	Grease (filled)	Any direction
		1/11	17.7	19.9					
		1/17	17.3	19.5					
		1/29	18.4	20.6		51	53		
		1/35	18.3	20.5					
		1/43	23.6	25.8					
HG-SR202(B)G1H HG-SR2024(B)G1H	2.0	1/6	50.0	59.4	4 times or less	37	43	Grease (filled)	Any direction
		1/11	48.4	57.8					
		1/17	48.1	57.5					
		1/29	54.8	64.2		92	98		
		1/35	54.5	63.9					
		1/43	54.3	63.7					
HG-SR352(B)G1H HG-SR3524(B)G1H	3.5	1/6	87.1	96.5	4 times or less	61	67	Oil (Note 3)	Shaft horizontal (Note 4)
		1/11	82.8	92.2					
		1/17	81.5	90.9					
		1/29	86.6	96.0		97	103		
		1/35	86.3	95.7					
		1/43	105	114					
HG-SR502(B)G1H HG-SR5024(B)G1H	5.0	1/6	126	135	4 times or less	101	107	Oil (Note 3)	Shaft horizontal (Note 4)
		1/11	114	123					
		1/17	110	119					
		1/29	141	150		178	184		
		1/35	140	150					
		1/43	139	149					
HG-SR702(B)G1H HG-SR7024(B)G1H	7.0	1/6	177	187	4 times or less	108	114	Oil (Note 3)	Shaft horizontal (Note 4)
		1/11	190	199					
		1/17	182	192					
		1/29	192	202		185	191		
		1/35	192	201					
		1/43	267	277					
		1/59	266	275		256	262		

- Notes: 1. The moments of inertia in the table are the values that are converted into motor shaft of the servo motor with gear reducer (and with electromagnetic brake).  
 2. Contact your local sales office if the load to motor inertia ratio exceeds the value in the table.  
 3. For applications where the servo motor moves, order a grease lubricated servo motor (special specification) instead of the oil lubricated. Note that the maximum speed of the grease lubricated servo motor is the same as that of the oil lubricated.  
 4. Do not mount the servo motor in a way that the servo motor is tilted to the shaft direction or to the shaft rotation direction. Refer to the asterisk 1 of "Annotations for Geared Servo Motor Specifications" on p. 2-70 in this catalog. Note that servo motors with special specifications may be available to be mounted with other than the shaft horizontal.  
 Refer to "Servo Motor Instruction Manual (Vol. 3)" for the available models.  
 5. The lubricant oil is removed from the gear reducer before shipment, and thus please purchase the required lubricant oil and fill the oil into the gear reducer.

### HG-SR Series Geared Servo Motor Specifications

With gear reducer for general industrial machines, foot mounting: G1H

Item	Specifications
Mounting method	Foot mounting
Output shaft rotating direction	Opposite from the servo motor output shaft direction
Backlash <sup>(Note 3)</sup>	40 minutes to 2° at reducer output shaft <sup>(Note 2)</sup>
Maximum torque	Three times of the rated torque (Refer to HG-SR 2000 r/min series specifications in this catalog for the rated torque.)
Maximum speed (at servo motor shaft)	For grease lubrication: 3000 r/min (permissible instantaneous speed: 3450 r/min) For oil lubrication: 2000 r/min (permissible instantaneous speed: 2300 r/min)
IP rating (gear reducer part)	Equivalent to IP44
Gear reducer efficiency <sup>(Note 1)</sup>	85% to 94%

- Notes: 1. The gear reducer efficiency varies depending on the reduction ratio and also varies with the conditions of use, such as output torque, speed, and temperature. The values in the table represent typical values at the rated torque and speed and at the normal temperature. They are not guaranteed values.  
 2. This is a designed value, not guaranteed value.  
 3. The backlash can be converted: 1 minute = 0.0167°

- Servo Amplifiers
- Rotary Servo Motors**
- Linear Servo Motors
- Direct Drive Motors
- Options/Peripheral Equipment
- LVS/Wires
- Product List
- Precautions



### HG-SR Series Geared Servo Motor Specifications

With flange-output type gear reducer for high precision applications, flange mounting: G5

Model	Output [kW]	Reduction ratio	Moment of inertia J [ $\times 10^{-4}$ kg·m <sup>2</sup> ] (Note 1)		Permissible load to motor inertia ratio (Note 2) (when converted into the servo motor shaft)	Mass [kg]		Lubrication method	Mounting direction
			Standard	With electromagnetic brake		Standard	With electromagnetic brake		
HG-SR52(B)G5 HG-SR524(B)G5	0.5	1/5	7.91	10.1	10 times or less	7.6	9.5	Grease (filled)	Any direction
		1/11	7.82	10.0		7.8	9.7		
		1/21	10.2	12.4		12	14		
		1/33	9.96	12.2					
		1/45	9.96	12.2					
HG-SR102(B)G5 HG-SR1024(B)G5	1.0	1/5	12.3	14.5	10 times or less	9.0	11		
		1/11	14.9	17.1		13	15		
		1/21	14.5	16.7		23	25		
		1/33	16.3	18.5					
		1/45	16.2	18.4					
HG-SR152(B)G5 HG-SR1524(B)G5	1.5	1/5	16.7	18.9	10 times or less	11	13		
		1/11	19.3	21.5		14	16		
		1/21	21.7	23.9		24	26		
		1/33	20.7	22.9					
		1/45	20.6	22.8					
HG-SR202(B)G5 HG-SR2024(B)G5	2.0	1/5	51.4	61.1	10 times or less	19	25		
		1/11	51.2	60.9		29	35		
		1/21	53.2	62.9					
		1/33	52.2	61.9					
		1/45	52.2	61.9					
HG-SR352(B)G5 HG-SR3524(B)G5	3.5	1/5	83.2	92.8	10 times or less	24	30		
		1/11	86.7	96.3		34	40		
		1/21	85.0	94.6					
HG-SR502(B)G5 HG-SR5024(B)G5	5.0	1/5	110	119	10 times or less	36	42		
		1/11	108	117		38	44		
HG-SR702(B)G5 HG-SR7024(B)G5	7.0	1/5	161	171	10 times or less	43	49		

Item	Specifications
Mounting method	Flange mounting
Output shaft rotating direction	Same as the servo motor output shaft direction
Backlash (Note 4)	3 minutes or less at gear reducer output shaft
Maximum torque	Three times of the rated torque (Refer to HG-SR 2000 r/min series specifications in this catalog for the rated torque.)
Maximum speed (at servo motor shaft)	3000 r/min (permissible instantaneous speed: 3450 r/min)
IP rating (gear reducer part)	Equivalent to IP44
Gear reducer efficiency (Note 3)	77% to 92%

- Notes: 1. The moments of inertia in the table are the values that are converted into motor shaft of the servo motor with gear reducer (and with electromagnetic brake).  
 2. Contact your local sales office if the load to motor inertia ratio exceeds the value in the table.  
 3. The gear reducer efficiency varies depending on the reduction ratio and also varies with the conditions of use, such as output torque, speed, and temperature. The values in the table represent typical values at the rated torque and speed and at the normal temperature. They are not guaranteed values.  
 4. The backlash can be converted: 1 minute = 0.0167°

Servo Amplifiers  
 Rotary Servo Motors  
 Linear Servo Motors  
 Direct Drive Motors  
 Options/Peripheral Equipment  
 LV/S/Wires  
 Product List  
 Precautions

# Rotary Servo Motors

## HG-SR Series Geared Servo Motor Dimensions (Note 1)

With flange-output type gear reducer for high precision applications, flange mounting

### ●HG-SR\_(B)G5

Drawing is schematic only, and the shapes or the mounting screws may differ from those of the actual servo motor. Refer to "Servo Motor Instruction Manual (Vol. 3)" for details.

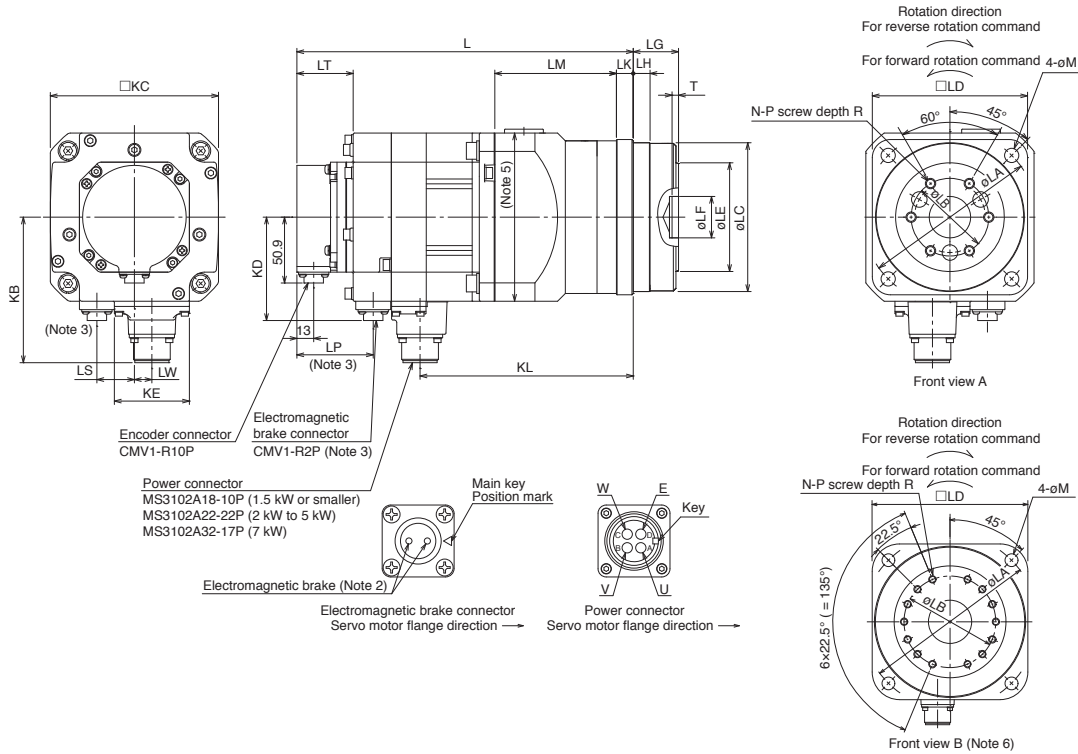

[Unit: mm]

Model	Reduction ratio	Variable dimensions (Note 4)																			Front view						
		L	LA	LB	LC	LD	LE	LF	LG	LH	LK	LM	LT	KL	LP	LW	LS	T	N	P		R	M	KB	KD	KC	KE
HG-SR52(B)G5 HG-SR524(B)G5	1/5	213.5 (248)	105	45	85h7	90	59	24H7	27 <sup>+0.4</sup> <sub>-0.5</sub>	8	10	85	38.2 (43.5)	152.8	(59)	13.5	(29)	5	6	M6	10	9	112.5	(79.9)	130	58	A
	1/11																										
	1/21																										
	1/33	225.5 (260)	135	60	115h7	120	84	32H7	35 <sup>+0.4</sup> <sub>-0.5</sub>	13	13	94	38.2 (43.5)	164.8	(59)	13.5	(29)	5	6	M8	12	11	112.5	(79.9)	130	58	A
1/45																											
HG-SR102(B)G5 HG-SR1024(B)G5	1/5	227.5 (262)	105	45	85h7	90	59	24H7	27 <sup>+0.4</sup> <sub>-0.5</sub>	8	10	85	38.2 (43.5)	166.8	(59)	13.5	(29)	5	6	M6	10	9	112.5	(79.9)	130	58	A
	1/11	239.5 (274)	135	60	115h7	120	84	32H7	35 <sup>+0.4</sup> <sub>-0.5</sub>	13	13	94	38.2 (43.5)	178.8	(59)	13.5	(29)	5	6	M8	12	11	112.5	(79.9)	130	58	A
	1/21																										
	1/33	255.5 (290)	190	100	165h8	170	122	47H7	53 <sup>+0.5</sup> <sub>-0.8</sub>	13	16	107	38.2 (43.5)	194.8	(59)	13.5	(29)	7	14	M8	12	14	112.5	(79.9)	130	58	B
1/45																											
HG-SR152(B)G5 HG-SR1524(B)G5	1/5	241.5 (276)	105	45	85h7	90	59	24H7	27 <sup>+0.4</sup> <sub>-0.5</sub>	8	10	85	38.2 (43.5)	180.8	(59)	13.5	(29)	5	6	M6	10	9	112.5	(79.9)	130	58	A
	1/11	253.5 (288)	135	60	115h7	120	84	32H7	35 <sup>+0.4</sup> <sub>-0.5</sub>	13	13	94	38.2 (43.5)	192.8	(59)	13.5	(29)	5	6	M8	12	11	112.5	(79.9)	130	58	A
	1/21																										
	1/33	269.5 (304)	190	100	165h8	170	122	47H7	53 <sup>+0.5</sup> <sub>-0.8</sub>	13	16	107	38.2 (43.5)	208.8	(59)	13.5	(29)	7	14	M8	12	14	112.5	(79.9)	130	58	B
1/45																											
HG-SR202(B)G5 HG-SR2024(B)G5	1/5	267.5 (317)	135	60	115h7	120	84	32H7	35 <sup>+0.4</sup> <sub>-0.5</sub>	13	13	116 (Note 5)	38.5 (45.5)	203.8	(66.5)	0	(44)	5	6	M8	12	11	140.9	(96.9)	176	82	A
	1/11																										
	1/21																										
	1/33	287.5 (337)	190	100	165h8	170	122	47H7	53 <sup>+0.5</sup> <sub>-0.8</sub>	13	16	133 (Note 5)	38.5 (45.5)	223.8	(66.5)	0	(44)	7	14	M8	12	14	140.9	(96.9)	176	82	B
1/45																											
HG-SR352(B)G5 HG-SR3524(B)G5	1/5	291.5 (341)	135	60	115h7	120	84	32H7	35 <sup>+0.4</sup> <sub>-0.5</sub>	13	13	116 (Note 5)	38.5 (45.5)	227.8	(66.5)	0	(44)	5	6	M8	12	11	140.9	(96.9)	176	82	A
	1/11	311.5 (361)	190	100	165h8	170	122	47H7	53 <sup>+0.5</sup> <sub>-0.8</sub>	13	16	133 (Note 5)	38.5 (45.5)	247.8	(66.5)	0	(44)	7	14	M8	12	14	140.9	(96.9)	176	82	B
HG-SR502(B)G5 HG-SR5024(B)G5	1/5	327.5 (377)	190	100	165h8	170	122	47H7	53 <sup>+0.5</sup> <sub>-0.8</sub>	13	16	133 (Note 5)	38.5 (45.5)	263.8	(66.5)	0	(44)	7	14	M8	12	14	140.9	(96.9)	176	82	B
	1/11																										
HG-SR702(B)G5 HG-SR7024(B)G5	1/5	367.5 (417)	190	100	165h8	170	122	47H7	53 <sup>+0.5</sup> <sub>-0.8</sub>	13	16	133 (Note 5)	38.5 (45.5)	295.8	(66.5)	0	(44)	7	14	M8	12	14	149.1	(96.9)	176	82	B
	1/11																										

- Notes: 1. For dimensions without tolerance, general tolerance applies. The actual dimensions may be 1 mm to 3 mm larger than the dimensions indicated since the outer frame of the gear reducer is made by casting. Make allowance for the actual dimensions in the design of a machine.  
 2. The electromagnetic brake terminals do not have polarity.  
 3. Only for the models with electromagnetic brake.  
 4. Dimensions in brackets are for the models with electromagnetic brake.  
 5. The models with (Note 5) in the LM column of the variable dimension table have the maximum dimension of 180 mm x 180 mm in this part.  
 6. For the front view B, the screws are not placed at equal intervals.



### HG-SR Series Geared Servo Motor Specifications

With shaft-output type gear reducer for high precision applications, flange mounting: G7

Model	Output [kW]	Reduction ratio	Moment of inertia J [ $\times 10^{-4}$ kg·m <sup>2</sup> ] (Note 1)		Permissible load to motor inertia ratio (Note 2) (when converted into the servo motor shaft)	Mass [kg]		Lubrication method	Mounting direction
			Standard	With electromagnetic brake		Standard	With electromagnetic brake		
HG-SR52(B)G7 HG-SR524(B)G7	0.5	1/5	7.95	10.2	10 times or less	8.0	9.9	Grease (filled)	Any direction
		1/11	7.82	10.0		8.2	11		
		1/21	10.2	12.4		13	15		
		1/33	9.96	12.2					
		1/45	9.96	12.2					
HG-SR102(B)G7 HG-SR1024(B)G7	1.0	1/5	12.3	14.5	10 times or less	9.4	12		
		1/11	15.0	17.2		15	17		
		1/21	14.5	16.7		26	28		
		1/33	16.3	18.5					
		1/45	16.3	18.5					
HG-SR152(B)G7 HG-SR1524(B)G7	1.5	1/5	16.7	18.9	10 times or less	11	13		
		1/11	19.4	21.6		16	18		
		1/21	21.7	23.9		27	29		
		1/33	20.7	22.9					
		1/45	20.7	22.9					
HG-SR202(B)G7 HG-SR2024(B)G7	2.0	1/5	51.7	61.4	10 times or less	20	26		
		1/11	51.3	61.0		21	27		
		1/21	53.3	63.0		32	38		
		1/33	52.2	61.9					
		1/45	52.2	61.9					
HG-SR352(B)G7 HG-SR3524(B)G7	3.5	1/5	83.5	93.1	10 times or less	25	31		
		1/11	87.0	96.6		37	43		
		1/21	85.1	94.7					
HG-SR502(B)G7 HG-SR5024(B)G7	5.0	1/5	111	121	10 times or less	39	45		
		1/11	108	117		41	47		
HG-SR702(B)G7 HG-SR7024(B)G7	7.0	1/5	163	173	10 times or less	46	52		

Item	Specifications
Mounting method	Flange mounting
Output shaft rotating direction	Same as the servo motor output shaft direction
Backlash (Note 4)	3 minutes or less at gear reducer output shaft
Maximum torque	Three times of the rated torque (Refer to HG-SR 2000 r/min series specifications in this catalog for the rated torque.)
Maximum speed (at servo motor shaft)	3000 r/min (permissible instantaneous speed: 3450 r/min)
IP rating (gear reducer part)	Equivalent to IP44
Gear reducer efficiency (Note 3)	77% to 92%

- Notes: 1. The moments of inertia in the table are the values that are converted into motor shaft of the servo motor with gear reducer (and with electromagnetic brake).  
 2. Contact your local sales office if the load to motor inertia ratio exceeds the value in the table.  
 3. The gear reducer efficiency varies depending on the reduction ratio and also varies with the conditions of use, such as output torque, speed, and temperature. The values in the table represent typical values at the rated torque and speed and at the normal temperature. They are not guaranteed values.  
 4. The backlash can be converted: 1 minute = 0.0167°

Servo Amplifiers  
 Rotary Servo Motors  
 Linear Servo Motors  
 Direct Drive Motors  
 Options/Peripheral Equipment  
 LV/S/Wires  
 Product List  
 Precautions

# Rotary Servo Motors

## HG-SR Series Geared Servo Motor Dimensions (Note 1, 5, 7)

With shaft-output type gear reducer for high precision applications, flange mounting

### ●HG-SR\_(B)G7

Drawing is schematic only, and the shapes or the mounting screws may differ from those of the actual servo motor. Refer to "Servo Motor Instruction Manual (Vol. 3)" for details.

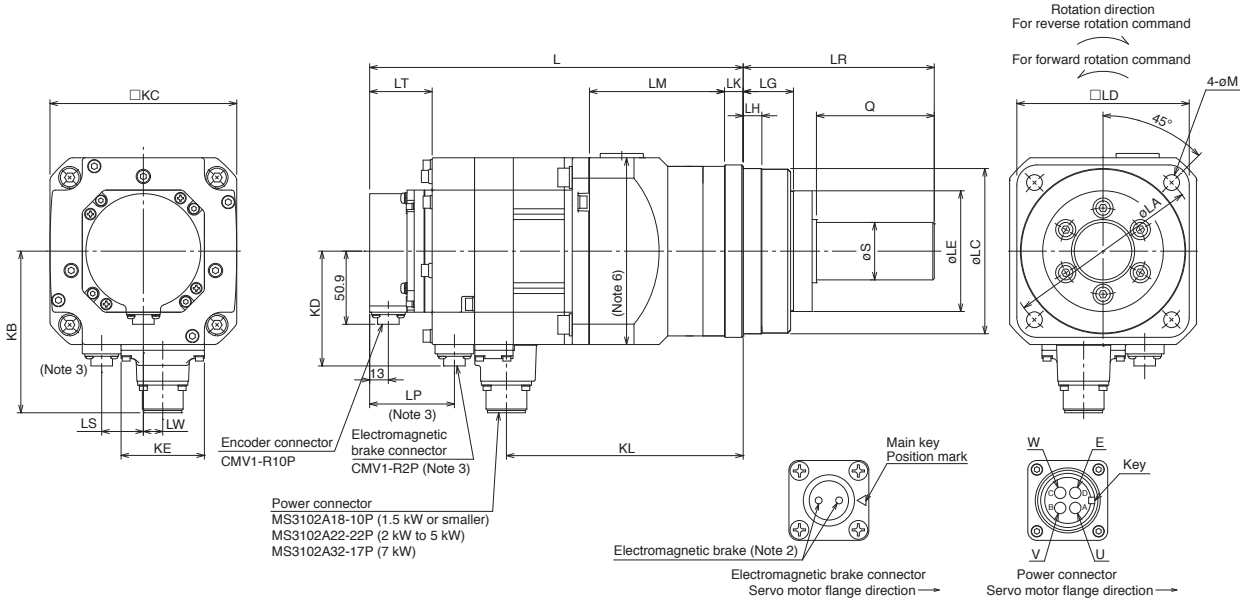

[Unit: mm]

Model	Reduction ratio	Variable dimensions (Note 4)																					
		L	LA	LC	LD	LE	S	LG	LH	Q	LR	LK	LM	LT	KL	LP	LW	LS	M	KB	KD	KC	KE
HG-SR52(B)G7 HG-SR524(B)G7	1/5	213.5 (248)	105	85h7	90	59	25h7	27	8	42	80	10	85	38.2 (43.5)	152.8	(59)	13.5	(29)	9	112.5	(79.9)	130	58
	1/11																						
	1/21																						
	1/33	225.5 (260)	135	115h7	120	84	40h7	35	13	82	133	13	94	38.2 (43.5)	164.8	(59)	13.5	(29)	11	112.5	(79.9)	130	58
1/45																							
HG-SR102(B)G7 HG-SR1024(B)G7	1/5	227.5 (262)	105	85h7	90	59	25h7	27	8	42	80	10	85	38.2 (43.5)	166.8	(59)	13.5	(29)	9	112.5	(79.9)	130	58
	1/11																						
	1/21	239.5 (274)	135	115h7	120	84	40h7	35	13	82	133	13	94	38.2 (43.5)	178.8	(59)	13.5	(29)	11	112.5	(79.9)	130	58
	1/33	255.5 (290)	190	165h8	170	122	50h7	53	13	82	156	16	107	38.2 (43.5)	194.8	(59)	13.5	(29)	14	112.5	(79.9)	130	58
1/45																							
HG-SR152(B)G7 HG-SR1524(B)G7	1/5	241.5 (288)	105	85h7	90	59	25h7	27	8	42	80	10	85	38.2 (43.5)	180.8	(59)	13.5	(29)	9	112.5	(79.9)	130	58
	1/11																						
	1/21	253.5 (288)	135	115h7	120	84	40h7	35	13	82	133	13	94	38.2 (43.5)	192.8	(59)	13.5	(29)	11	112.5	(79.9)	130	58
	1/33	269.5 (304)	190	165h8	170	122	50h7	53	13	82	156	16	107	38.2 (43.5)	208.8	(59)	13.5	(29)	14	112.5	(79.9)	130	58
1/45																							
HG-SR202(B)G7 HG-SR2024(B)G7	1/5	267.5 (317)	135	115h7	120	84	40h7	35	13	82	133	13	116 (Note 6)	38.5 (45.5)	203.8	(66.5)	0	(44)	11	140.9	(96.9)	176	82
	1/11																						
	1/21	287.5 (337)	190	165h8	170	122	50h7	53	13	82	156	16	133 (Note 6)	38.5 (45.5)	223.8	(66.5)	0	(44)	14	140.9	(96.9)	176	82
	1/33																						
1/45																							
HG-SR352(B)G7 HG-SR3524(B)G7	1/5	291.5 (341)	135	115h7	120	84	40h7	35	13	82	133	13	116 (Note 6)	38.5 (45.5)	227.8	(66.5)	0	(44)	11	140.9	(96.9)	176	82
	1/11																						
	1/21	311.5 (361)	190	165h8	170	122	50h7	53	13	82	156	16	133 (Note 6)	38.5 (45.5)	247.8	(66.5)	0	(44)	14	140.9	(96.9)	176	82
HG-SR502(B)G7 HG-SR5024(B)G7	1/5	327.5 (377)	190	165h8	170	122	50h7	53	13	82	156	16	133 (Note 6)	38.5 (45.5)	263.8	(66.5)	0	(44)	14	140.9	(96.9)	176	82
	1/11																						
HG-SR702(B)G7 HG-SR7024(B)G7	1/5	367.5 (417)	190	165h8	170	122	50h7	53	13	82	156	16	133 (Note 6)	38.5 (45.5)	295.8	(66.5)	0	(44)	14	149.1	(96.9)	176	82
	1/11																						

Notes: 1. For dimensions without tolerance, general tolerance applies. The actual dimensions may be 1 mm to 3 mm larger than the dimensions indicated since the outer frame of the gear reducer is made by casting. Make allowance for the actual dimensions in the design of a machine.

2. The electromagnetic brake terminals do not have polarity.

3. Only for the models with electromagnetic brake.

4. Dimensions in brackets are for the models with electromagnetic brake.

5. Use a friction coupling to fasten a load.

6. The models with (Note 6) in the LM column of the variable dimension table have the maximum dimension of 180 mm × 180 mm in this part.

7. HG-SR\_(B)G7K is also available for key shaft motor (with key). Refer to the following page for the shaft-end shape.

### HG-SR Series Geared Servo Motor Special Shaft End Specifications

Standard HG-SR\_(B)G1/G1H (with gear reducer for general industrial machines) has a key shaft (with key).

Standard HG-SR\_(B)G7 (with shaft-output type gear reducer for high precision applications, flange mounting) has a straight shaft.

HG-SR\_(B)G7K is also available for key shaft motor (with key). Refer to the following for the shaft-end shape.

Key shaft (with key) (Note 1, 2, 3)

Model	Reduction ratio	Variable dimensions						
		S	Q	W	QK	U	T	Y
HG-SR52(B)G7K HG-SR524(B)G7K	1/5	25	42	8	36	4	7	M6 screw Depth: 12
	1/11							
	1/21							
	1/33							
	1/45							
HG-SR102(B)G7K HG-SR1024(B)G7K	1/5	40	82	12	70	5	8	M6 screw Depth: 12
	1/11							
	1/21							
	1/33							
	1/45							
HG-SR152(B)G7K HG-SR1524(B)G7K	1/5	40	82	12	70	5	8	M6 screw Depth: 12
	1/11							
	1/21							
	1/33							
	1/45							
HG-SR202(B)G7K HG-SR2024(B)G7K	1/5	50	82	14	70	5.5	9	M10 screw Depth: 20
	1/11							
	1/21							
	1/33							
	1/45							
HG-SR352(B)G7K HG-SR3524(B)G7K	1/5	50	82	14	70	5.5	9	M10 screw Depth: 20
	1/11							
	1/21							
	1/33							
	1/45							
HG-SR502(B)G7K HG-SR5024(B)G7K	1/5	50	82	14	70	5.5	9	M10 screw Depth: 20
	1/11							
	1/21							
	1/33							
	1/45							
HG-SR702(B)G7K HG-SR7024(B)G7K	1/5	50	82	14	70	5.5	9	M10 screw Depth: 20
	1/11							

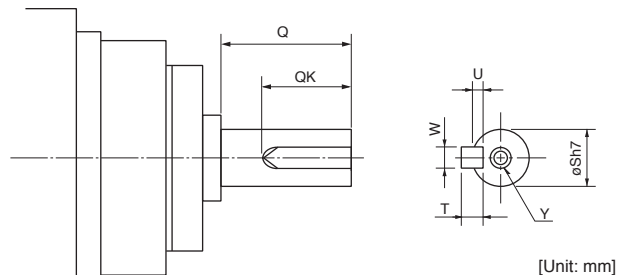

- Notes: 1. Do not use servo motors with key shafts for frequent start/stop applications as this may cause damage to the shaft.  
 2. A single pointed key is attached.  
 3. The dimensions not mentioned in the drawings are the same as those of the straight shaft. Refer to HG-SR\_(B)G7 dimensions in this catalog.

### Annotations for Geared Servo Motor Specifications

- \* 1. Do not mount the following servo motor in a way that the servo motor is tilted to the shaft direction or to the shaft rotation direction.
- HG-SR102(4)(B)G1/G1H 1/43, 1/59
  - HG-SR152(4)(B)G1/G1H 1/29, 1/35, 1/43, 1/59
  - HG-SR202(4)(B)G1/G1H 1/29, 1/35, 1/43, 1/59
  - HG-SR352(4)(B)G1/G1H all reduction ratios
  - HG-SR502(4)(B)G1/G1H all reduction ratios
  - HG-SR702(4)(B)G1/G1H all reduction ratios

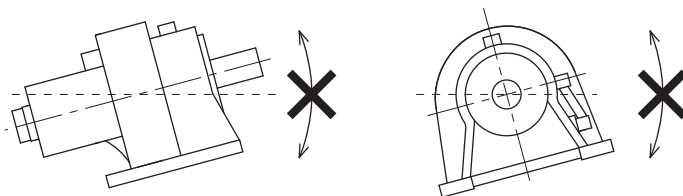

# Rotary Servo Motors

## Rotary Servo Motor Sizing Example

### 1. Selection criteria

#### (1) Configurations

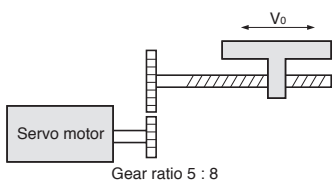

Feed speed of moving part	$V_0 = 30000 \text{ mm/min}$	$D_B = \text{ball screw diameter}$	20 mm
Feed length per cycle	$\ell = 400 \text{ mm}$	$L_B = \text{ball screw length}$	500 mm
Positioning time	$t_0 = \text{within } 1 \text{ s}$	$D_{G1} = \text{gear diameter (servo motor shaft)}$	25 mm
Number of feed times (Operating cycle)	40 times/min	$D_{G2} = \text{gear diameter (load shaft)}$	40 mm
Reduction ratio	$1/n = 5/8$	$L_G = \text{gear tooth thickness}$	10 mm
Moving part mass	$W = 60 \text{ kg}$		
Drive system efficiency	$\eta = 0.8$		
Friction coefficient	$\mu = 0.2$		
Ball screw lead	$P_B = 16 \text{ mm}$		

#### (2) Servo motor speed

$$N_0 = \frac{V_0}{P_B} \times \frac{1}{1/n} = \frac{30000}{16} \times \frac{8}{5} = 3000 \text{ r/min}$$

#### (3) Acceleration/deceleration time constant

$$t_{psa} = t_{psd} = t_0 - \frac{\ell}{V_0/60} - t_s = 0.05 \text{ s}$$

$t_s$ : settling time. Here assumed 0.15 s.

#### (4) Operation pattern

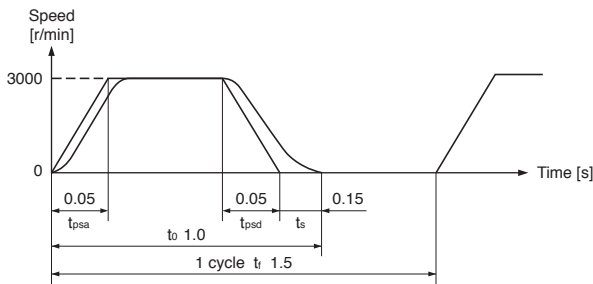

#### (3) Select a servo motor

##### Selection criteria

- Load torque < Rated torque of servo motor
- Moment of inertia of all loads <  $J_R \times$  Moment of inertia of servo motor

$J_R$ : Recommended load to motor inertia ratio

Select the following servo motor to meet the criteria above.

HG-KR23 (rated torque: 0.64 N·m, max. torque: 2.2 N·m, moment of inertia:  $0.221 \times 10^{-4} \text{ kg}\cdot\text{m}^2$ )

#### (4) Acceleration/deceleration torque

Torque required during acceleration

$$T_{Ma} = \frac{(J_L/\eta + J_M) \times N_0}{9.55 \times 10^4 \times t_{psa}} + T_L = 1.84 \text{ N}\cdot\text{m}$$

$J_M$ : moment of inertia of servo motor

Torque required during deceleration

$$T_{Md} = -\frac{(J_L \times \eta + J_M) \times N_0}{9.55 \times 10^4 \times t_{psd}} + T_L = -0.85 \text{ N}\cdot\text{m}$$

Torque required during acceleration/deceleration must be equal to or lower than the max. torque of the servo motor.

## 2. Selecting rotary servo motor

#### (1) Load torque (converted into the servo motor shaft)

Travel distance per servo motor revolution

$$\Delta S = P_B \times \frac{1}{n} = 10 \text{ mm}$$

$$T_L = \frac{\mu \times W \times g \times \Delta S}{2 \times 10^3 \pi \eta} = 0.23 \text{ N}\cdot\text{m}$$

#### (2) Moment of inertia of load (converted into the servo motor shaft)

Moving part

$$J_{L1} = W \times \left( \frac{\Delta S \times 10^{-3}}{2 \pi} \right)^2 = 1.52 \times 10^{-4} \text{ kg}\cdot\text{m}^2$$

Ball screw

$$J_{L2} = \frac{\pi \times \rho \times L_B}{32} \times D_B^4 \times \left( \frac{1}{n} \right)^2 = 0.24 \times 10^{-4} \text{ kg}\cdot\text{m}^2$$

$\rho = 7.8 \times 10^3 \text{ kg/m}^3$  (iron)

Gear (servo motor shaft)

$$J_{L3} = \frac{\pi \times \rho \times L_G}{32} \times D_{G1}^4 = 0.03 \times 10^{-4} \text{ kg}\cdot\text{m}^2$$

Gear (load shaft)

$$J_{L4} = \frac{\pi \times \rho \times L_G}{32} \times D_{G2}^4 \times \left( \frac{1}{n} \right)^2 = 0.08 \times 10^{-4} \text{ kg}\cdot\text{m}^2$$

Moment of inertia of all loads (converted into the servo motor shaft)

$$J_L = J_{L1} + J_{L2} + J_{L3} + J_{L4} = 1.87 \times 10^{-4} \text{ kg}\cdot\text{m}^2$$

#### (5) Continuous effective load torque

$$T_{rms} = \sqrt{\frac{T_{Ma}^2 \times t_{psa} + T_L^2 \times t_c + T_{Md}^2 \times t_{psd}}{t_i}} = 0.40 \text{ N}\cdot\text{m}$$

$t_c = t_0 - t_s - t_{psa} - t_{psd}$

Continuous effective load torque must be equal to or lower than the rated torque of the servo motor.

#### (6) Torque pattern

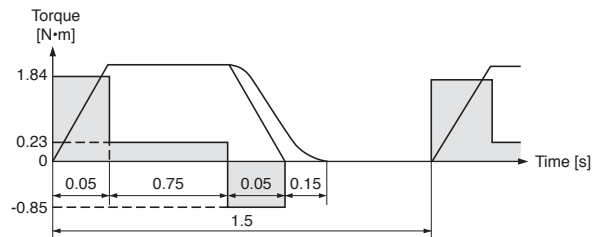

#### (7) Result

Select the following:

Servo motor: HG-KR23

Servo amplifier: MR-J4-20B

[Drive System Sizing Software Motorizer]  
Motorizer does all the calculations for you. Contact your local sales office for more details.

# 3

## Linear Servo Motors

Model Designation .....	3-1
Combinations of Linear Servo Motor and Servo Amplifier.....	3-5
Specifications	
LM-H3 series.....	3-7
LM-F series .....	3-9
LM-K2 series.....	3-11
LM-U2 series.....	3-13
Dimensions	
LM-H3 series.....	3-15
LM-F series .....	3-17
LM-K2 series.....	3-19
LM-U2 series.....	3-21
List of Linear Encoders .....	3-23
Sizing Example.....	3-25

\* Refer to p. 5-99 in this catalog for conversion of units.

\* The characteristics and numerical values without tolerances mentioned in this catalog are representative values.

# Linear Servo Motors

## Model Designation (Note 1)

● LM-H3 series

**L M - H 3 P 2 A - 0 7 P -** (Primary side: coil)

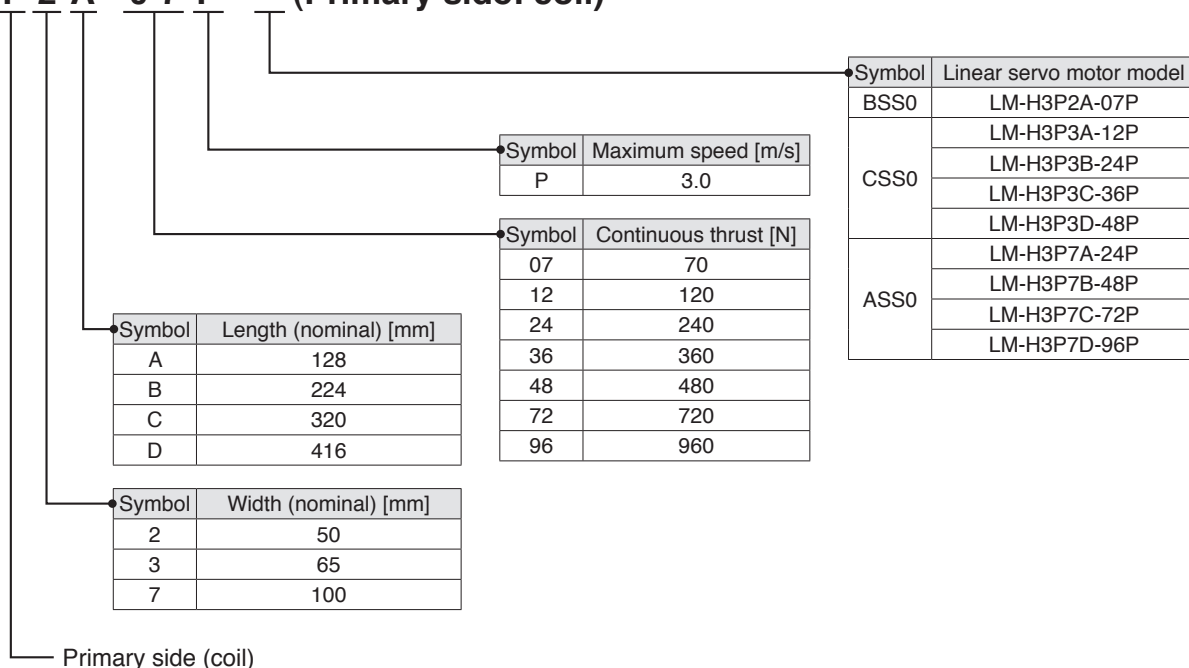

**L M - H 3 S 2 0 - 2 8 8 -** (Secondary side: magnet)

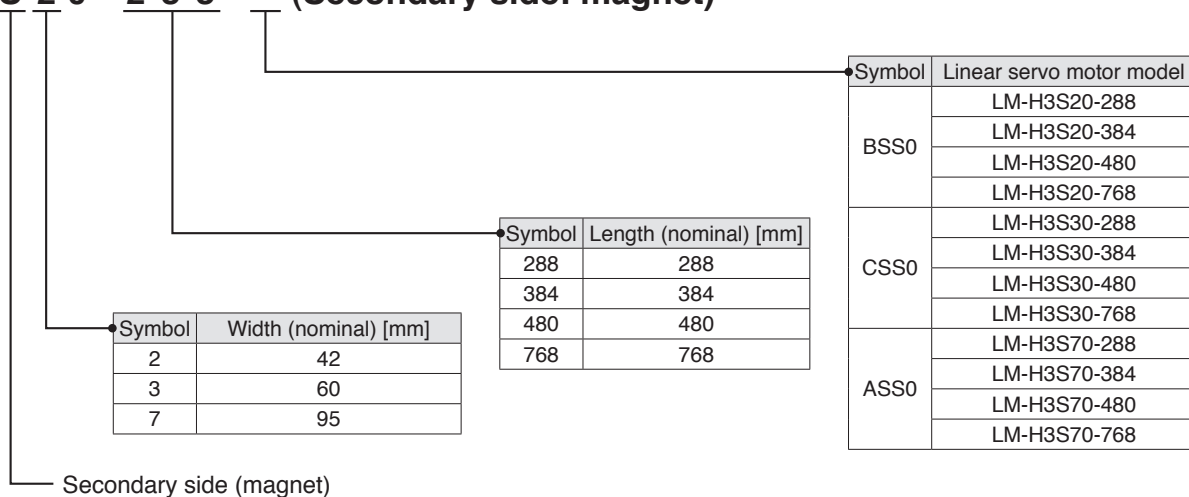

Notes: 1. This section describes what each symbol in a model name indicates. Some combinations of symbols are not available.

**Model Designation** (Note 1)

● LM-F series

**LM - FP 2 B - 0 6 M -** (Primary side: coil)

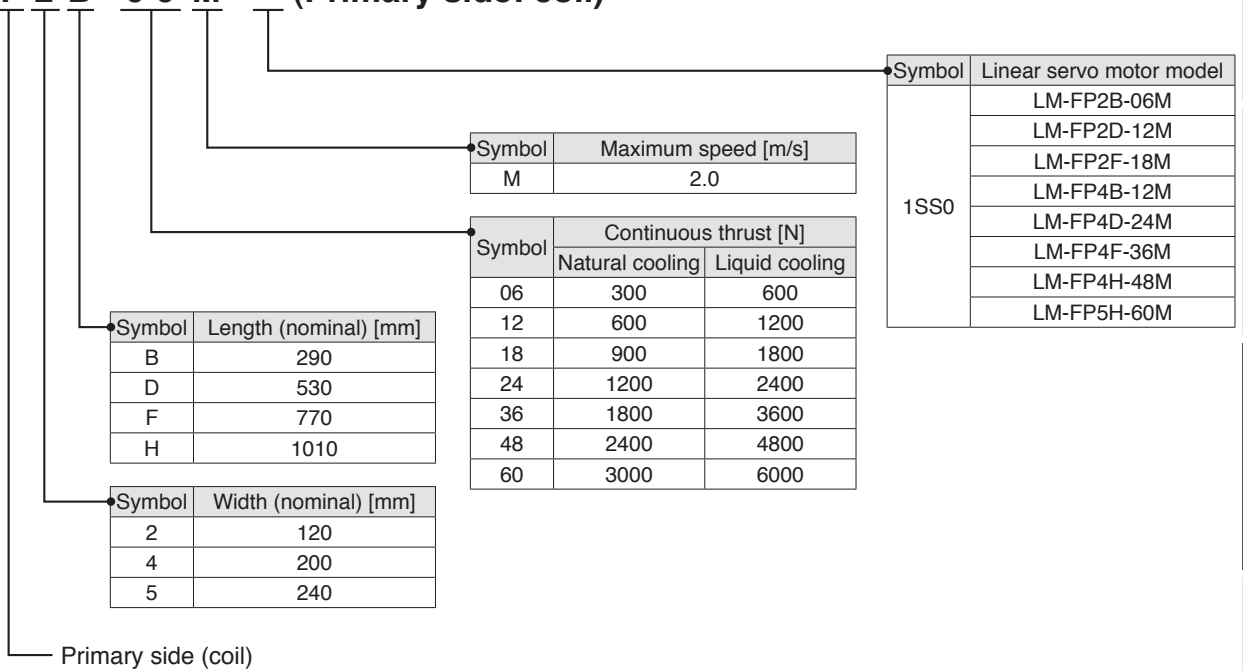

**LM - FS 2 0 - 4 8 0 -** (Secondary side: magnet)

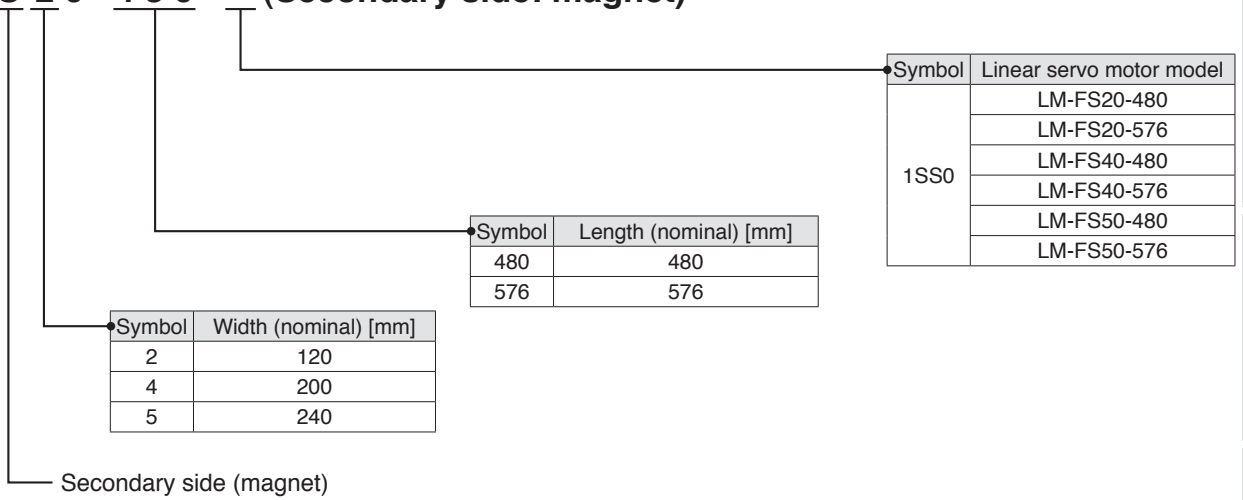

Notes: 1. This section describes what each symbol in a model name indicates. Some combinations of symbols are not available.

# Linear Servo Motors

## Model Designation (Note 1)

● LM-K2 series

### LM - K 2 P 1 A - 0 1 M - (Primary side: coil)

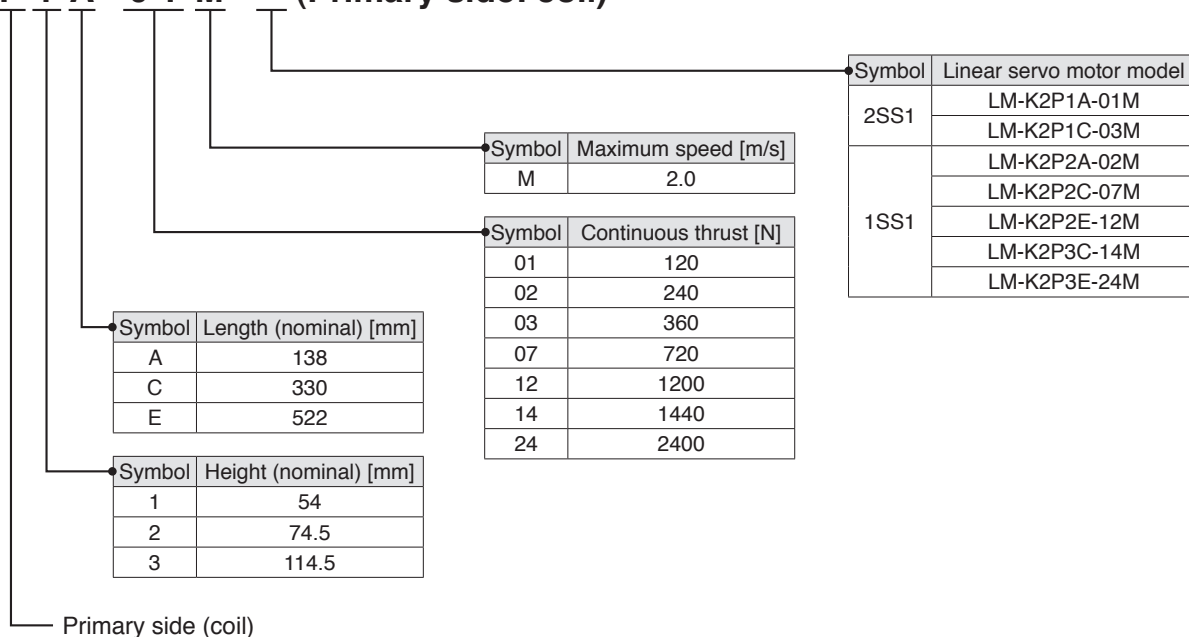

### LM - K 2 S 1 0 - 2 8 8 - (Secondary side: magnet)

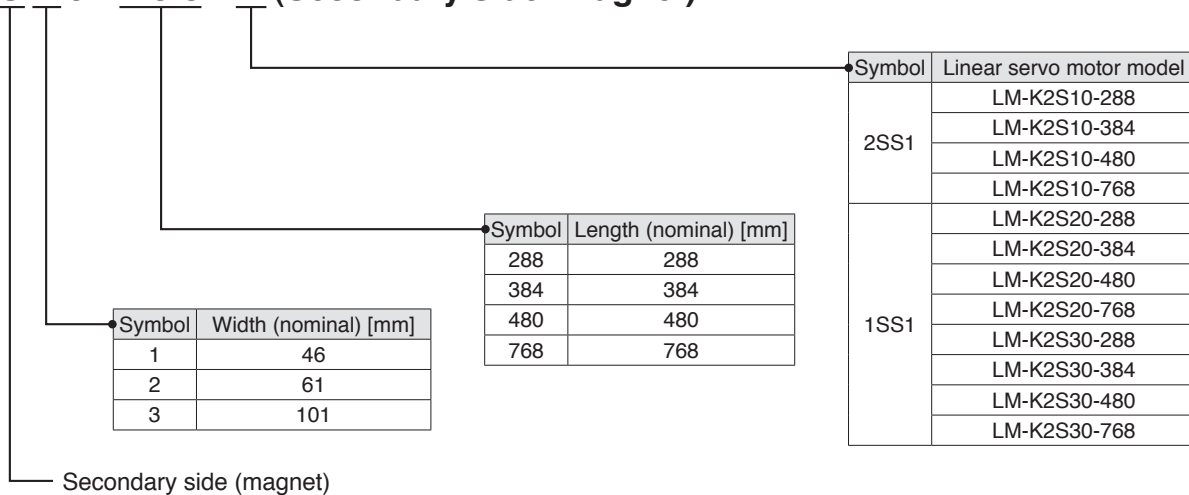

Notes: 1. This section describes what each symbol in a model name indicates. Some combinations of symbols are not available.



**Model Designation** (Note 1)

●LM-U2 (medium thrust) series

**LM - U 2 P A B - 0 5 M -** (Primary side: coil)

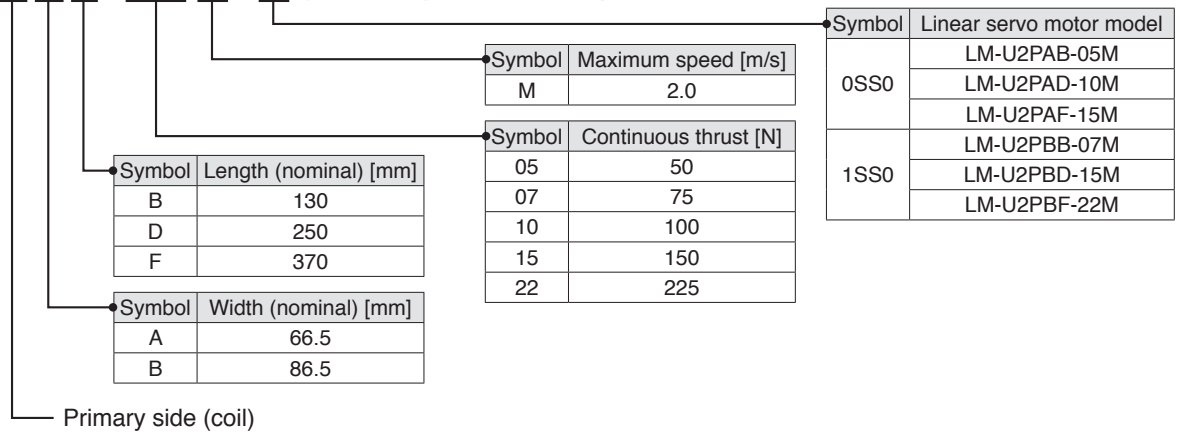

**LM - U 2 S A 0 - 2 4 0 -** (Secondary side: magnet)

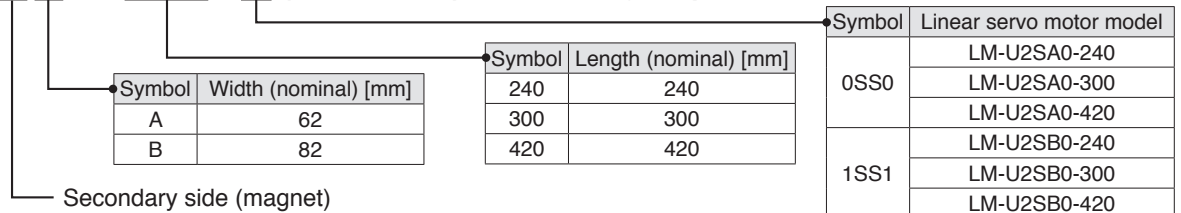

●LM-U2 (large thrust) series

**LM - U 2 P 2 B - 4 0 M -** (Primary side: coil)

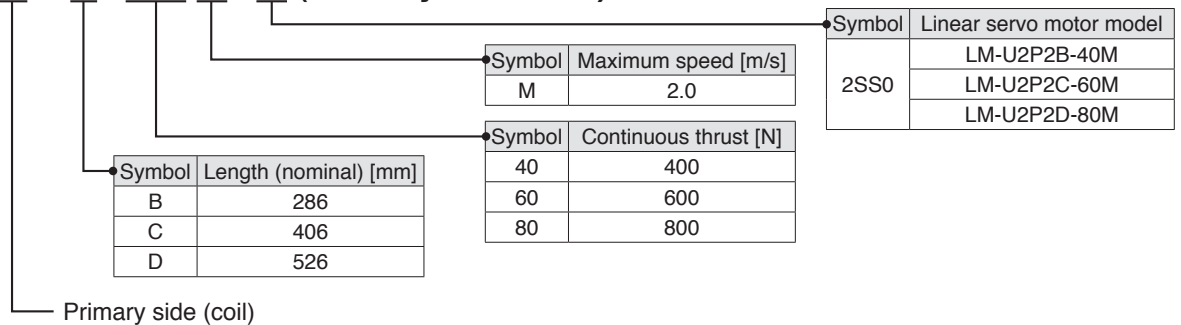

**LM - U 2 S 2 0 - 3 0 0 -** (Secondary side: magnet)

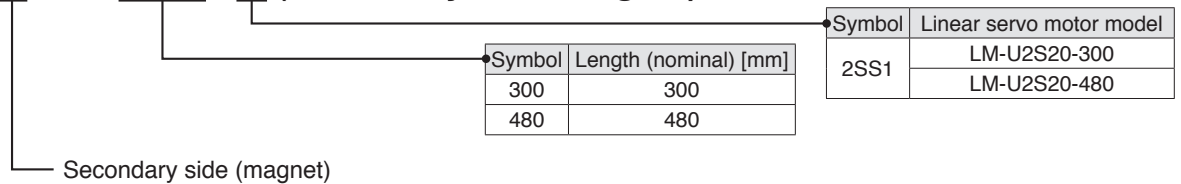

Notes: 1. This section describes what each symbol in a model name indicates. Some combinations of symbols are not available.

# Linear Servo Motors

## Combinations of Linear Servo Motor and Servo Amplifier

	Linear servo motor		Servo amplifier/Drive unit		
	Primary side (coil)	Secondary side (magnet)	MR-J4	MR-J4W2 (Note 1)	MR-J4W3 (Note 1)
LM-H3 series	LM-H3P2A-07P-BSS0	LM-H3S20-288-BSS0, LM-H3S20-384-BSS0, LM-H3S20-480-BSS0, LM-H3S20-768-BSS0	MR-J4-40GF(-RJ) (Note 2), MR-J4-40GF1(-RJ), MR-J4-40B(-RJ), MR-J4-40B1(-RJ), MR-J4-40A(-RJ), MR-J4-40A1(-RJ)	MR-J4W2-44B, MR-J4W2-77B, MR-J4W2-1010B	MR-J4W3-444B
	LM-H3P3A-12P-CSS0		MR-J4-40GF(-RJ) (Note 2), MR-J4-40GF1(-RJ), MR-J4-40B(-RJ), MR-J4-40B1(-RJ), MR-J4-40A(-RJ), MR-J4-40A1(-RJ)	MR-J4W2-44B, MR-J4W2-77B, MR-J4W2-1010B	MR-J4W3-444B
	LM-H3P3B-24P-CSS0	LM-H3S30-288-CSS0, LM-H3S30-384-CSS0, LM-H3S30-480-CSS0, LM-H3S30-768-CSS0	MR-J4-70GF(-RJ) (Note 2), MR-J4-70B(-RJ), MR-J4-70A(-RJ)	MR-J4W2-77B, MR-J4W2-1010B	-
	LM-H3P3C-36P-CSS0		MR-J4-70GF(-RJ) (Note 2), MR-J4-70B(-RJ), MR-J4-70A(-RJ)	MR-J4W2-77B, MR-J4W2-1010B	-
	LM-H3P3D-48P-CSS0		MR-J4-200GF(-RJ) (Note 2), MR-J4-200B(-RJ), MR-J4-200A(-RJ)	-	-
	LM-H3P7A-24P-ASS0		MR-J4-70GF(-RJ) (Note 2), MR-J4-70B(-RJ), MR-J4-70A(-RJ)	MR-J4W2-77B, MR-J4W2-1010B	-
	LM-H3P7B-48P-ASS0	LM-H3S70-288-ASS0, LM-H3S70-384-ASS0, LM-H3S70-480-ASS0, LM-H3S70-768-ASS0	MR-J4-200GF(-RJ) (Note 2), MR-J4-200B(-RJ), MR-J4-200A(-RJ)	-	-
	LM-H3P7C-72P-ASS0		MR-J4-200GF(-RJ) (Note 2), MR-J4-200B(-RJ), MR-J4-200A(-RJ)	-	-
LM-H3P7D-96P-ASS0		MR-J4-350GF(-RJ) (Note 2), MR-J4-350B(-RJ), MR-J4-350A(-RJ)	-	-	
LM-F series	LM-FP2B-06M-1SS0		MR-J4-200GF(-RJ) (Note 2), MR-J4-200B(-RJ), MR-J4-200A(-RJ)	-	-
	LM-FP2D-12M-1SS0	LM-FS20-480-1SS0, LM-FS20-576-1SS0	MR-J4-500GF(-RJ) (Note 2), MR-J4-500B(-RJ), MR-J4-500A(-RJ)	-	-
	LM-FP2F-18M-1SS0		MR-J4-700GF(-RJ) (Note 2), MR-J4-700B(-RJ), MR-J4-DU900B(-RJ), MR-J4-700A(-RJ)	-	-
	LM-FP4B-12M-1SS0		MR-J4-500GF(-RJ) (Note 2), MR-J4-500B(-RJ), MR-J4-500A(-RJ)	-	-
	LM-FP4D-24M-1SS0		MR-J4-700GF(-RJ) (Note 2), MR-J4-700B(-RJ), MR-J4-DU900B(-RJ), MR-J4-700A(-RJ)	-	-
	LM-FP4F-36M-1SS0	LM-FS40-480-1SS0, LM-FS40-576-1SS0	MR-J4-11KGF(-RJ) (Note 2), MR-J4-11KB(-RJ), MR-J4-DU11KB(-RJ), MR-J4-11KA(-RJ)	-	-
	LM-FP4H-48M-1SS0		MR-J4-15KGF(-RJ) (Note 2), MR-J4-15KB(-RJ), MR-J4-DU15KB(-RJ), MR-J4-15KA(-RJ)	-	-
LM-FP5H-60M-1SS0	LM-FS50-480-1SS0, LM-FS50-576-1SS0	MR-J4-22KGF4(-RJ) (Note 2), MR-J4-22KB4(-RJ), MR-J4-DU22KB4(-RJ), MR-J4-22KA4(-RJ)	-	-	

Notes: 1. Any combination of the servo motors is available. Refer to "Combinations of Multi-Axis Servo Amplifier and Servo Motors" on p. 1-8 in this catalog.  
2. MR-J4-GF(-RJ) with software version A1 or later supports the linear servo motor.

Combinations of Linear Servo Motor and Servo Amplifier

	Linear servo motor		Servo amplifier			
	Primary side (coil)	Secondary side (magnet)	MR-J4	MR-J4W2 (Note 1)	MR-J4W3 (Note 1)	
LM-K2 series	LM-K2P1A-01M-2SS1	LM-K2S10-288-2SS1, LM-K2S10-384-2SS1, LM-K2S10-480-2SS1, LM-K2S10-768-2SS1	MR-J4-40GF(-RJ) (Note 2), MR-J4-40GF1(-RJ), MR-J4-40B(-RJ), MR-J4-40B1(-RJ), MR-J4-40A(-RJ), MR-J4-40A1(-RJ)	MR-J4W2-44B, MR-J4W2-77B, MR-J4W2-1010B	MR-J4W3-444B	Servo Amplifiers Rotary Servo Motors Linear Servo Motors Direct Drive Motors Options/Peripheral Equipment LVs/Wires Product List Precautions
	LM-K2P1C-03M-2SS1		MR-J4-200GF(-RJ) (Note 2), MR-J4-200B(-RJ), MR-J4-200A(-RJ)	-	-	
	LM-K2P2A-02M-1SS1	LM-K2S20-288-1SS1, LM-K2S20-384-1SS1, LM-K2S20-480-1SS1, LM-K2S20-768-1SS1	MR-J4-70GF(-RJ) (Note 2), MR-J4-70B(-RJ), MR-J4-70A(-RJ)	MR-J4W2-77B, MR-J4W2-1010B	-	
	LM-K2P2C-07M-1SS1		MR-J4-350GF(-RJ) (Note 2), MR-J4-350B(-RJ), MR-J4-350A(-RJ)	-	-	
	LM-K2P2E-12M-1SS1		MR-J4-500GF(-RJ) (Note 2), MR-J4-500B(-RJ), MR-J4-500A(-RJ)	-	-	
	LM-K2P3C-14M-1SS1	LM-K2S30-288-1SS1, LM-K2S30-384-1SS1, LM-K2S30-480-1SS1, LM-K2S30-768-1SS1	MR-J4-350GF(-RJ) (Note 2), MR-J4-350B(-RJ), MR-J4-350A(-RJ)	-	-	
	LM-K2P3E-24M-1SS1		MR-J4-500GF(-RJ) (Note 2), MR-J4-500B(-RJ), MR-J4-500A(-RJ)	-	-	
LM-U2 series	LM-U2PAB-05M-0SS0	LM-U2SA0-240-0SS0, LM-U2SA0-300-0SS0, LM-U2SA0-420-0SS0	MR-J4-20GF(-RJ) (Note 2), MR-J4-20GF1(-RJ), MR-J4-20B(-RJ), MR-J4-20B1(-RJ), MR-J4-20A(-RJ), MR-J4-20A1(-RJ)	MR-J4W2-22B, MR-J4W2-44B	MR-J4W3-222B, MR-J4W3-444B	
	LM-U2PAD-10M-0SS0		MR-J4-40GF(-RJ) (Note 2), MR-J4-40GF1(-RJ), MR-J4-40B(-RJ), MR-J4-40B1(-RJ), MR-J4-40A(-RJ), MR-J4-40A1(-RJ)	MR-J4W2-44B, MR-J4W2-77B, MR-J4W2-1010B	MR-J4W3-444B	
	LM-U2PAF-15M-0SS0		MR-J4-40GF(-RJ) (Note 2), MR-J4-40GF1(-RJ), MR-J4-40B(-RJ), MR-J4-40B1(-RJ), MR-J4-40A(-RJ), MR-J4-40A1(-RJ)	MR-J4W2-44B, MR-J4W2-77B, MR-J4W2-1010B	MR-J4W3-444B	
	LM-U2PBB-07M-1SS0	LM-U2SB0-240-1SS1, LM-U2SB0-300-1SS1, LM-U2SB0-420-1SS1	MR-J4-20GF(-RJ) (Note 2), MR-J4-20GF1(-RJ), MR-J4-20B(-RJ), MR-J4-20B1(-RJ), MR-J4-20A(-RJ), MR-J4-20A1(-RJ)	MR-J4W2-22B, MR-J4W2-44B	MR-J4W3-222B, MR-J4W3-444B	
	LM-U2PBD-15M-1SS0		MR-J4-60GF(-RJ) (Note 2), MR-J4-60B(-RJ), MR-J4-60A(-RJ)	MR-J4W2-77B, MR-J4W2-1010B	-	
	LM-U2PBF-22M-1SS0	MR-J4-70GF(-RJ) (Note 2), MR-J4-70B(-RJ), MR-J4-70A(-RJ)	MR-J4W2-77B, MR-J4W2-1010B	-		
	LM-U2P2B-40M-2SS0	LM-U2S20-300-2SS1, LM-U2S20-480-2SS1	MR-J4-200GF(-RJ) (Note 2), MR-J4-200B(-RJ), MR-J4-200A(-RJ)	-	-	
	LM-U2P2C-60M-2SS0		MR-J4-350GF(-RJ) (Note 2), MR-J4-350B(-RJ), MR-J4-350A(-RJ)	-	-	
	LM-U2P2D-80M-2SS0		MR-J4-500GF(-RJ) (Note 2), MR-J4-500B(-RJ), MR-J4-500A(-RJ)	-	-	

Notes: 1. Any combination of the servo motors is available. Refer to "Combinations of Multi-Axis Servo Amplifier and Servo Motors" on p. 1-8 in this catalog.  
2. MR-J4-GF(-RJ) with software version A1 or later supports the linear servo motor.

# Linear Servo Motors

## LM-H3 Series Specifications

Linear servo motor model	Primary side (coil)	LM-H3	P2A-07P-BSS0	P3A-12P-CSS0	P3B-24P-CSS0	P3C-36P-CSS0	P3D-48P-CSS0	P7A-24P-ASS0	P7B-48P-ASS0	P7C-72P-ASS0	P7D-96P-ASS0
	Secondary side (magnet)	LM-H3	S20-288-BSS0 S20-384-BSS0 S20-480-BSS0 S20-768-BSS0		S30-288-CSS0 S30-384-CSS0 S30-480-CSS0 S30-768-CSS0				S70-288-ASS0 S70-384-ASS0 S70-480-ASS0 S70-768-ASS0		
Compatible servo amplifier model	MR-J4- MR-J4W_-	Refer to "Combinations of Linear Servo Motor and Servo Amplifier" on p. 3-5 in this catalog.									
Power supply capacity <sup>(Note 6)</sup>	[kVA]	0.9	0.9	1.3	1.9	3.5	1.3	3.5	3.8	5.5	
Cooling method	Natural cooling										
Thrust	Continuous <sup>(Note 5)</sup>	[N]	70	120	240	360	480	240	480	720	960
	Maximum	[N]	175	300	600	900	1200	600	1200	1800	2400
Maximum speed <sup>(Note 1)</sup>	[m/s]	3.0									
Magnetic attraction force	[N]	630	1100	2200	3300	4400	2200	4400	6600	8800	
Rated current	[A]	1.8	1.7	3.4	5.1	6.8	3.4	6.8	10.2	13.6	
Maximum current	[A]	5.8	5.0	9.9	14.9	19.8	9.6	19.1	28.6	38.1	
Regenerative braking frequency <sup>(Note 2)</sup>	MR-J4-	[times/min]	175	95	108	78	300	108	308	210	159
	MR-J4W_-	[times/min]	173 <sup>(Note 3)</sup>	95 <sup>(Note 4)</sup>	271	197	-	241	-	-	-
Recommended load to motor mass ratio <sup>(Note 7)</sup>	Maximum of 35 times the mass of the linear servo motor primary side										
Type	Permanent magnet synchronous motor										
Thermistor	Built-in										
Insulation class	155 (F)										
Structure	Open (IP rating: IP00)										
Environment <sup>(Note 8)</sup>	Ambient temperature	Operation: 0 °C to 40 °C (non-freezing), storage: -15 °C to 70 °C (non-freezing)									
	Ambient humidity	Operation: 10 %RH to 80 %RH (non-condensing), storage: 10 %RH to 90 %RH (non-condensing)									
	Ambience	Indoors (no direct sunlight); no corrosive gas, inflammable gas, oil mist or dust									
	Altitude	1000 m or less above sea level									
	Vibration resistance	49 m/s <sup>2</sup>									
Mass	Primary side (coil)	[kg]	0.9	1.3	2.3	3.3	4.3	2.2	3.9	5.6	7.3
	Secondary side (magnet)	[kg]	288 mm/pc: 0.7 384 mm/pc: 0.9 480 mm/pc: 1.1 768 mm/pc: 1.8		288 mm/pc: 1.0 384 mm/pc: 1.4 480 mm/pc: 1.7 768 mm/pc: 2.7				288 mm/pc: 2.8 384 mm/pc: 3.7 480 mm/pc: 4.7 768 mm/pc: 7.4		

Notes: 1. The maximum speed of the linear servo motor or the rated speed of the linear encoder, whichever is smaller, is the upper limit of the linear servo motor speed.

2. The regenerative braking frequency shows the permissible frequency when the linear servo motor, without a load and a regenerative option, decelerates from the maximum speed to a stop. When a load is connected, the value will be the table value/(m+1), where m = Mass of load/Mass of motor primary side (coil). Take measures to keep the regenerative power [W] during operation below the permissible regenerative power [W]. Use caution, especially when the operating speed changes frequently or when the regeneration is constant (as with vertical feeds). Select the most suitable regenerative option for your system with our drive system sizing software Motorizer. Refer to "Regenerative Option" in this catalog for the permissible regenerative power [W] when a regenerative option is used.

3. This value is applicable when MR-J4W2-44B or MR-J4W3-444B is used. The value is 942 for MR-J4W2-77B or MR-J4W2-1010B.

4. This value is applicable when MR-J4W2-44B or MR-J4W3-444B is used. The value is 497 for MR-J4W2-77B or MR-J4W2-1010B.

5. Use the linear servo motor at 70% or less of the effective load ratio when it is in the servo lock state or in a small reciprocating motion.

6. The power supply capacity varies depending on the power supply impedance.

The listed values are the power supply capacity for one servo motor. For the multi-axis servo amplifiers, calculate the power supply capacity with the equation below:

Power supply capacity [kVA] = Sum of power supply capacity [kVA] of the connected servo motors

7. This is the ratio of the load to the linear servo motor primary side mass. Contact your local sales office if the load to motor mass ratio exceeds the value in the table.

8. Do not use the linear servo motors in the environment where the linear servo motors are exposed to oil mist, oil and/or water.

LM-H3 Series Thrust Characteristics

LM-H3P2A-07P-BSS0 (Note 1, 2, 4)

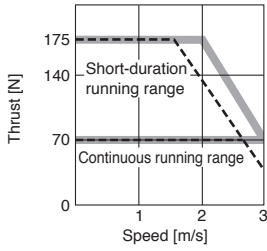

LM-H3P3A-12P-CSS0 (Note 1, 2, 4)

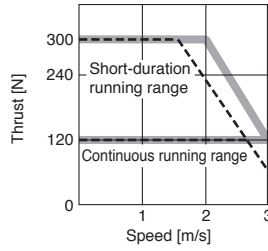

LM-H3P3B-24P-CSS0 (Note 1, 3, 4)

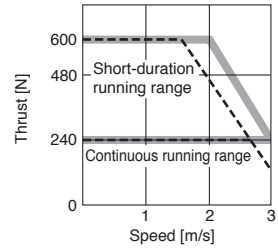

LM-H3P3C-36P-CSS0 (Note 1, 3, 4)

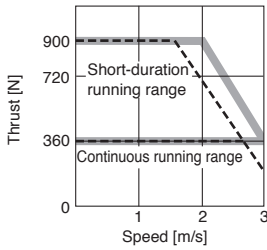

LM-H3P3D-48P-CSS0 (Note 1, 3, 4)

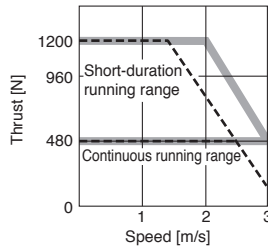

LM-H3P7A-24P-ASS0 (Note 1, 3, 4)

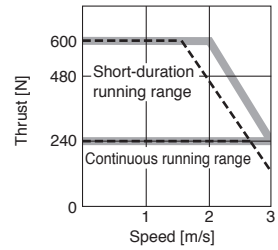

LM-H3P7B-48P-ASS0 (Note 1, 3, 4)

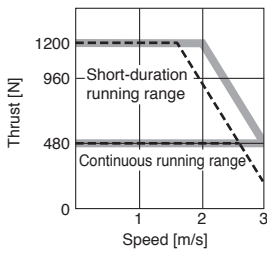

LM-H3P7C-72P-ASS0 (Note 1, 3, 4)

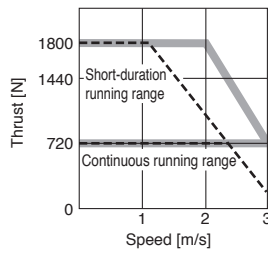

LM-H3P7D-96P-ASS0 (Note 1, 4)

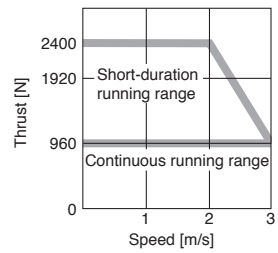

- Notes: 1. — : For 3-phase 200 V AC.
- 2. - - - : For 1-phase 200 V AC or 1-phase 100 V AC.
- 3. - · - · : For 1-phase 200 V AC.
- 4. Thrust drops when the power supply voltage is below the specified value.

# Linear Servo Motors

## LM-F Series Specifications

Linear servo motor model	Primary side (coil)	LM-F	P2B-06M-1SS0	P2D-12M-1SS0	P2F-18M-1SS0	P4B-12M-1SS0	P4D-24M-1SS0	P4F-36M-1SS0	P4H-48M-1SS0	P5H-60M-1SS0 (Note 3)
	Secondary side (magnet)	LM-F	S20-480-1SS0 S20-576-1SS0			S40-480-1SS0 S40-576-1SS0			S50-480-1SS0 (Note 3) S50-576-1SS0 (Note 3)	
Compatible servo amplifier model		MR-J4-	Refer to "Combinations of Linear Servo Motor and Servo Amplifier" on p. 3-5 in this catalog.							
Power supply capacity (Note 5)		[kVA]	3.5	7.5	10	7.5	10	14	18	22
Cooling method			Natural cooling or liquid cooling							
Thrust	Continuous (natural cooling) (Note 4)	[N]	300	600	900	600	1200	1800	2400	3000
	Continuous (liquid cooling) (Note 4)	[N]	600	1200	1800	1200	2400	3600	4800	6000
	Maximum	[N]	1800	3600	5400	3600	7200	10800	14400	18000
Maximum speed (Note 1)		[m/s]	2.0							
Magnetic attraction force		[N]	4500	9000	13500	9000	18000	27000	36000	45000
Rated current	Natural cooling	[A]	4.0	7.8	12	7.8	15	21	28	22
	Liquid cooling	[A]	7.8	16	23	17	31	44	59	45
Maximum current		[A]	30	58	87	57	109	159	212	157
Regenerative braking frequency (Note 2)	MR-J4-	Natural cooling [times/min]	348	264	318	393	169	577	715	4230
		Liquid cooling [times/min]	671	396	No limit	366	224	859	1050	No limit
Recommended load to motor mass ratio (Note 6)			Maximum of 15 times the mass of the linear servo motor primary side							
Type			Permanent magnet synchronous motor							
Thermistor			Built-in							
Insulation class			155 (F)							
Structure			Open (IP rating: IP00)							
Environment (Note 7)	Ambient temperature		Operation: 0 °C to 40 °C (non-freezing), storage: -15 °C to 70 °C (non-freezing)							
	Ambient humidity		Operation: 10 %RH to 80 %RH (non-condensing), storage: 10 %RH to 90 %RH (non-condensing)							
	Ambience		Indoors (no direct sunlight); no corrosive gas, inflammable gas, oil mist or dust							
	Altitude		1000 m or less above sea level							
	Vibration resistance		49 m/s <sup>2</sup>							
Mass	Primary side (coil)	[kg]	9.0	18	27	14	28	42	56	67
	Secondary side (magnet)	[kg]	480 mm/pc: 7.0 576 mm/pc: 9.0			480 mm/pc: 12 576 mm/pc: 15			480 mm/pc: 20 576 mm/pc: 24	

- Notes: 1. The maximum speed of the linear servo motor or the rated speed of the linear encoder, whichever is smaller, is the upper limit of the linear servo motor speed.
2. The regenerative braking frequency shows the permissible frequency when the linear servo motor, without a load and a regenerative option, decelerates from the maximum speed to a stop. When a load is connected, the value will be the table value/(m+1), where m = Mass of load/Mass of motor primary side (coil). Take measures to keep the regenerative power [W] during operation below the permissible regenerative power [W]. Use caution, especially when the operating speed changes frequently or when the regeneration is constant (as with vertical feeds). Select the most suitable regenerative option for your system with our drive system sizing software Motorizer. Refer to "Regenerative Option" in this catalog for the permissible regenerative power [W] when a regenerative option is used.
3. Use a 400 V AC type servo amplifier for this linear servo motor.
4. Use the linear servo motor at 70% or less of the effective load ratio when it is in the servo lock state or in a small reciprocating motion.
5. The power supply capacity varies depending on the power supply impedance.  
The listed values are the power supply capacity for one servo motor. For the multi-axis servo amplifiers, calculate the power supply capacity with the equation below:  
Power supply capacity [kVA] = Sum of power supply capacity [kVA] of the connected servo motors
6. This is the ratio of the load to the linear servo motor primary side mass. Contact your local sales office if the load to motor mass ratio exceeds the value in the table.
7. Do not use the linear servo motors in the environment where the linear servo motors are exposed to oil mist, oil and/or water.

LM-F Series Thrust Characteristics

LM-FP2B-06M-1SS0 (Note 1, 3, 4)

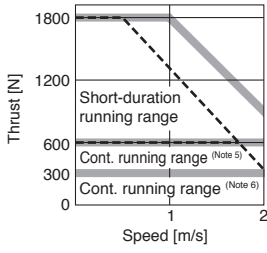

LM-FP2D-12M-1SS0 (Note 1, 4)

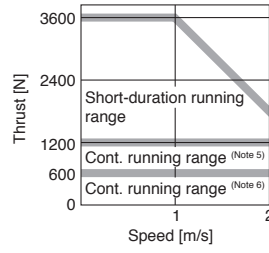

LM-FP2F-18M-1SS0 (Note 1, 4)

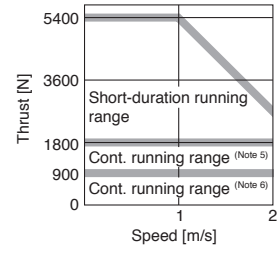

LM-FP4B-12M-1SS0 (Note 1, 4)

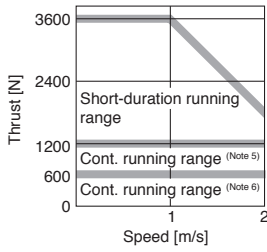

LM-FP4D-24M-1SS0 (Note 1, 4)

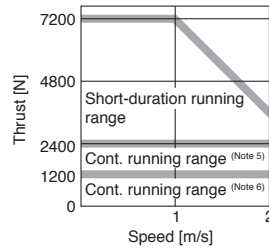

LM-FP4F-36M-1SS0 (Note 1, 4)

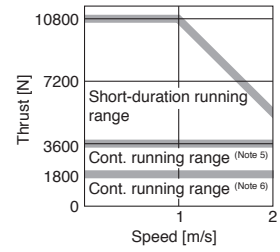

LM-FP4H-48M-1SS0 (Note 1, 4)

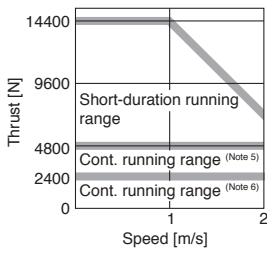

LM-FP5H-60M-1SS0 (Note 2, 4)

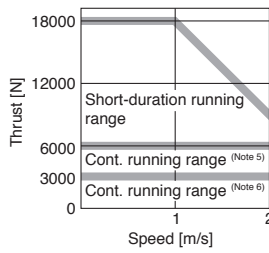

- Notes: 1. : For 3-phase 200 V AC.
- 2. : For 3-phase 400 V AC.
- 3. : For 1-phase 200 V AC.
- 4. Thrust drops when the power supply voltage is below the specified value.
- 5. Continuous running range (liquid cooling)
- 6. Continuous running range (natural cooling)

# Linear Servo Motors

## LM-K2 Series Specifications

Linear servo motor model	Primary side (coil)	LM-K2	P1A-01M-2SS1	P1C-03M-2SS1	P2A-02M-1SS1	P2C-07M-1SS1	P2E-12M-1SS1	P3C-14M-1SS1	P3E-24M-1SS1
	Secondary side (magnet) <small>(Note 4)</small>	LM-K2	S10-288-2SS1 S10-384-2SS1 S10-480-2SS1 S10-768-2SS1			S20-288-1SS1 S20-384-1SS1 S20-480-1SS1 S20-768-1SS1		S30-288-1SS1 S30-384-1SS1 S30-480-1SS1 S30-768-1SS1	
Compatible servo amplifier model	MR-J4- MR-J4W_ -	Refer to "Combinations of Linear Servo Motor and Servo Amplifier" on p. 3-6 in this catalog.							
Power supply capacity <small>(Note 8)</small>	[kVA]	0.9	3.5	1.3	5.5	7.5	5.5	7.5	
Cooling method	Natural cooling								
Thrust	Continuous <small>(Note 5)</small>	[N]	120	360	240	720	1200	1440	2400
	Maximum	[N]	300	900	600	1800	3000	3600	6000
Maximum speed <small>(Note 1)</small>	[m/s]	2.0							
Magnetic attraction force <small>(Note 6)</small>	[N]	0							
Magnetic attraction force (one side) <small>(Note 7)</small>	[N]	800	2400	1100	3200	5300	6400	10700	
Rated current	[A]	2.3	6.8	3.7	12	19	15	25	
Maximum current	[A]	7.6	23	13	39	65	47	79	
Regenerative braking frequency <small>(Note 2)</small>	MR-J4- [times/min]	111	427	142	281	226	152	124	
	MR-J4W_ - [times/min]	110 <small>(Note 3)</small>	-	355	-	-	-	-	
Recommended load to motor mass ratio <small>(Note 9)</small>	Maximum of 30 times the mass of the linear servo motor primary side								
Type	Permanent magnet synchronous motor								
Thermistor	Built-in								
Insulation class	155 (F)								
Structure	Open (IP rating: IP00)								
Environment <small>(Note 10)</small>	Ambient temperature	Operation: 0 °C to 40 °C (non-freezing), storage: -15 °C to 70 °C (non-freezing)							
	Ambient humidity	Operation: 10 %RH to 80 %RH (non-condensing), storage: 10 %RH to 90 %RH (non-condensing)							
	Ambience	Indoors (no direct sunlight); no corrosive gas, inflammable gas, oil mist or dust							
	Altitude	1000 m or less above sea level							
	Vibration resistance	49 m/s <sup>2</sup>							
Mass	Primary side (coil) [kg]	2.5	6.5	4.0	10	16	18	27	
	Secondary side (magnet) [kg]	288 mm/pc: 1.5 384 mm/pc: 2.0 480 mm/pc: 2.5 768 mm/pc: 3.9		288 mm/pc: 1.9 384 mm/pc: 2.5 480 mm/pc: 3.2 768 mm/pc: 5.0			288 mm/pc: 5.5 384 mm/pc: 7.3 480 mm/pc: 9.2 768 mm/pc: 14.6		

- Notes: 1. The maximum speed of the linear servo motor or the rated speed of the linear encoder, whichever is smaller, is the upper limit of the linear servo motor speed.
2. The regenerative braking frequency shows the permissible frequency when the linear servo motor, without a load and a regenerative option, decelerates from the maximum speed to a stop. When a load is connected, the value will be the table value/(m+1), where m = Mass of load/Mass of motor primary side (coil). Take measures to keep the regenerative power [W] during operation below the permissible regenerative power [W]. Use caution, especially when the operating speed changes frequently or when the regeneration is constant (as with vertical feeds). Select the most suitable regenerative option for your system with our drive system sizing software Motorizer. Refer to "Regenerative Option" in this catalog for the permissible regenerative power [W] when a regenerative option is used.
3. This value is applicable when MR-J4W2-44B or MR-J4W3-444B is used. The value is 584 for MR-J4W2-77B or MR-J4W2-1010B.
4. LM-K2 series has a structure of magnetic attraction counter-force and requires at least two blocks of identical secondary side (magnet).
5. Use the linear servo motor at 70% or less of the effective load ratio when it is in the servo lock state or in a small reciprocating motion.
6. Magnetic attraction force is caused by assembly precision, etc.
7. Magnetic attraction force which occurs on one side of the secondary side is shown.
8. The power supply capacity varies depending on the power supply impedance.  
The listed values are the power supply capacity for one servo motor. For the multi-axis servo amplifiers, calculate the power supply capacity with the equation below:  
Power supply capacity [kVA] = Sum of power supply capacity [kVA] of the connected servo motors
9. This is the ratio of the load to the linear servo motor primary side mass. Contact your local sales office if the load to motor mass ratio exceeds the value in the table.
10. Do not use the linear servo motors in the environment where the linear servo motors are exposed to oil mist, oil and/or water.



LM-K2 Series Thrust Characteristics

LM-K2P1A-01M-2SS1 (Note 1, 3, 5)

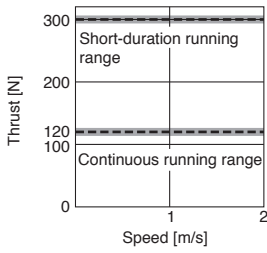

LM-K2P1C-03M-2SS1 (Note 2, 4, 5)

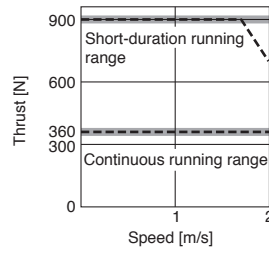

LM-K2P2A-02M-1SS1 (Note 1, 5)

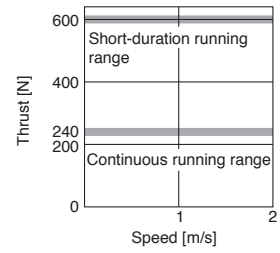

LM-K2P2C-07M-1SS1 (Note 2, 5)

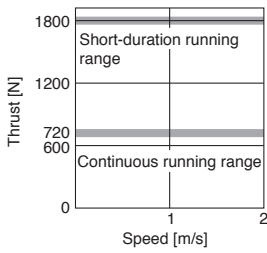

LM-K2P2E-12M-1SS1 (Note 2, 5)

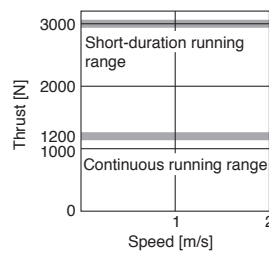

LM-K2P3C-14M-1SS1 (Note 2, 5)

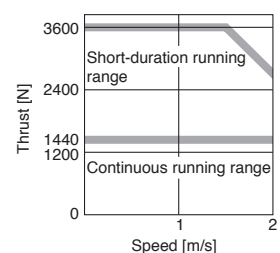

LM-K2P3E-24M-1SS1 (Note 2, 5)

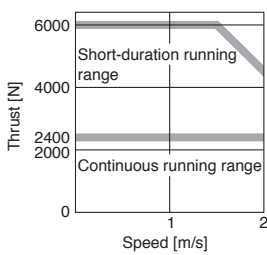

- Notes: 1. — : For 3-phase 200 V AC or 1-phase 200 V AC.  
 2. — : For 3-phase 200 V AC.  
 3. - - - : For 1-phase 100 V AC.  
 4. - - - : For 1-phase 200 V AC.  
 5. Thrust drops when the power supply voltage is below the specified value.

# Linear Servo Motors

## LM-U2 Series Specifications

Linear servo motor model	Primary side (coil)	LM-U2	PAB-05M-0SS0	PAD-10M-0SS0	PAF-15M-0SS0	PBB-07M-1SS0	PBD-15M-1SS0	PBF-22M-1SS0	P2B-40M-2SS0	P2C-60M-2SS0	P2D-80M-2SS0
	Secondary side (magnet)	LM-U2	SA0-240-0SS0 SA0-300-0SS0 SA0-420-0SS0			SB0-240-1SS1 SB0-300-1SS1 SB0-420-1SS1			S20-300-2SS1 S20-480-2SS1		
Compatible servo amplifier model	MR-J4- MR-J4W_-	Refer to "Combinations of Linear Servo Motor and Servo Amplifier" on p. 3-6 in this catalog.									
Power supply capacity <sup>(Note 4)</sup>	[kVA]	0.5	0.9	0.9	0.5	1.0	1.3	3.5	5.5	7.5	
Cooling method		Natural cooling									
Thrust	Continuous <sup>(Note 3)</sup>	[N]	50	100	150	75	150	225	400	600	800
	Maximum	[N]	150	300	450	225	450	675	1600	2400	3200
Maximum speed <sup>(Note 1)</sup>	[m/s]	2.0									
Magnetic attraction force	[N]	0									
Rated current	[A]	0.9	1.9	2.7	1.5	3.0	4.6	6.6	9.8	13.1	
Maximum current	[A]	2.7	5.5	8.3	4.5	8.9	13.7	26.7	40.3	53.7	
Regenerative braking frequency <sup>(Note 2)</sup>	MR-J4- [times/min]	No limit	No limit	No limit	No limit	3480	No limit	1820	2800	1190	
	MR-J4W_- [times/min]	No limit	No limit	No limit	6030	No limit	No limit	-	-	-	
Recommended load to motor mass ratio <sup>(Note 5)</sup>		Maximum of 30 times the mass of the linear servo motor primary side									
Type		Permanent magnet synchronous motor									
Thermistor		Built-in									
Insulation class		155 (F)									
Structure		Open (IP rating: IP00)									
Environment <sup>(Note 6)</sup>	Ambient temperature	Operation: 0 °C to 40 °C (non-freezing), storage: -15 °C to 70 °C (non-freezing)									
	Ambient humidity	Operation: 10 %RH to 80 %RH (non-condensing), storage: 10 %RH to 90 %RH (non-condensing)									
	Ambience	Indoors (no direct sunlight); no corrosive gas, inflammable gas, oil mist or dust									
	Altitude	1000 m or less above sea level									
	Vibration resistance	49 m/s <sup>2</sup>									
Mass	Primary side (coil) [kg]	0.3	0.6	0.8	0.4	0.8	1.1	2.9	4.2	5.5	
	Secondary side (magnet) [kg]	240 mm/pc: 2.0 300 mm/pc: 2.5 420 mm/pc: 3.5			240 mm/pc: 2.6 300 mm/pc: 3.2 420 mm/pc: 4.5			300 mm/pc: 9.6 480 mm/pc: 15.3			

Notes: 1. The maximum speed of the linear servo motor or the rated speed of the linear encoder, whichever is smaller, is the upper limit of the linear servo motor speed.

2. The regenerative braking frequency shows the permissible frequency when the linear servo motor, without a load and a regenerative option, decelerates from the maximum speed to a stop. When a load is connected, the value will be the table value/(m+1), where m = Mass of load/Mass of motor primary side (coil). Take measures to keep the regenerative power [W] during operation below the permissible regenerative power [W]. Use caution, especially when the operating speed changes frequently or when the regeneration is constant (as with vertical feeds). Select the most suitable regenerative option for your system with our drive system sizing software Motorizer. Refer to "Regenerative Option" in this catalog for the permissible regenerative power [W] when a regenerative option is used.

3. Use the linear servo motor at 70% or less of the effective load ratio when it is in the servo lock state or in a small reciprocating motion.

4. The power supply capacity varies depending on the power supply impedance.

The listed values are the power supply capacity for one servo motor. For the multi-axis servo amplifiers, calculate the power supply capacity with the equation below:

Power supply capacity [kVA] = Sum of power supply capacity [kVA] of the connected servo motors

5. This is the ratio of the load to the linear servo motor primary side mass. Contact your local sales office if the load to motor mass ratio exceeds the value in the table.

6. Do not use the linear servo motors in the environment where the linear servo motors are exposed to oil mist, oil and/or water.

LM-U2 Series Thrust Characteristics

LM-U2PAB-05M-0SS0 (Note 1, 3, 5)

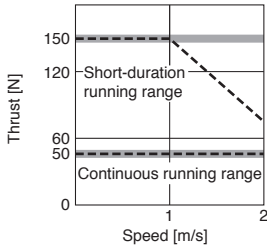

LM-U2PAD-10M-0SS0 (Note 1, 3, 5)

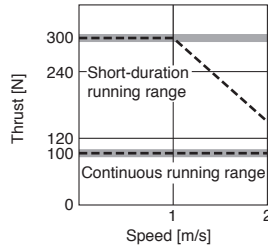

LM-U2PAF-15M-0SS0 (Note 1, 3, 5)

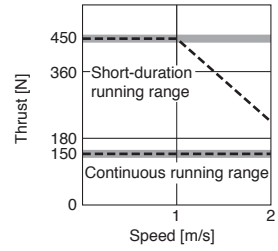

LM-U2PBB-07M-1SS0 (Note 1, 3, 5)

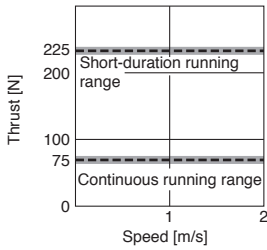

LM-U2PBD-15M-1SS0 (Note 1, 5)

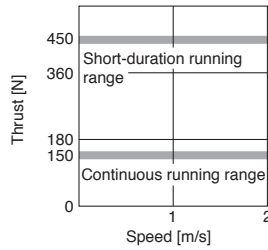

LM-U2PBF-22M-1SS0 (Note 1, 5)

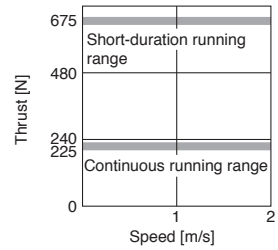

LM-U2P2B-40M-2SS0 (Note 2, 4, 5)

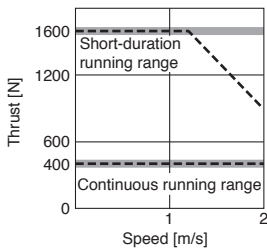

LM-U2P2C-60M-2SS0 (Note 2, 5)

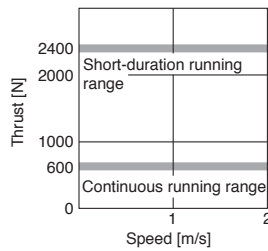

LM-U2P2D-80M-2SS0 (Note 2, 5)

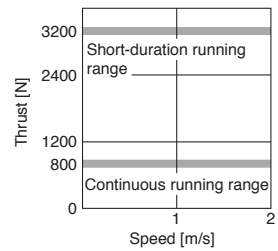

- Notes: 1. : For 3-phase 200 V AC or 1-phase 200 V AC.  
 2. : For 3-phase 200 V AC.  
 3. : For 1-phase 100 V AC.  
 4. : For 1-phase 200 V AC.  
 5. Thrust drops when the power supply voltage is below the specified value.

# Linear Servo Motors

## LM-H3 Series Primary Side (Coil) Dimensions (Note 1, 2)

### ●LM-H3P2A-07P-BSS0

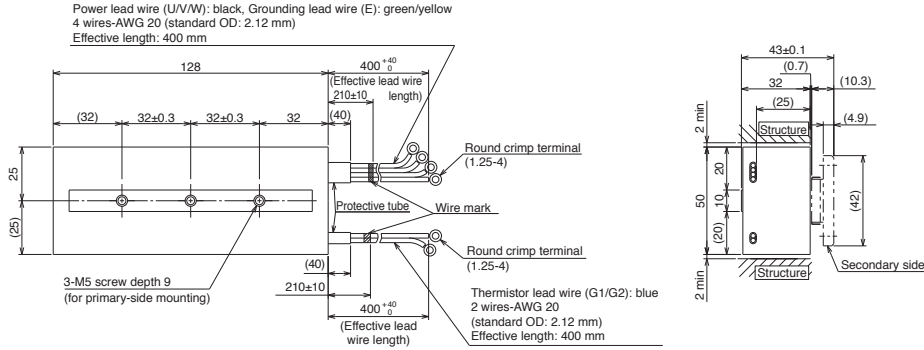

[Unit: mm]

### ●LM-H3P3A-12P-CSS0

### ●LM-H3P3B-24P-CSS0

### ●LM-H3P3C-36P-CSS0

### ●LM-H3P3D-48P-CSS0

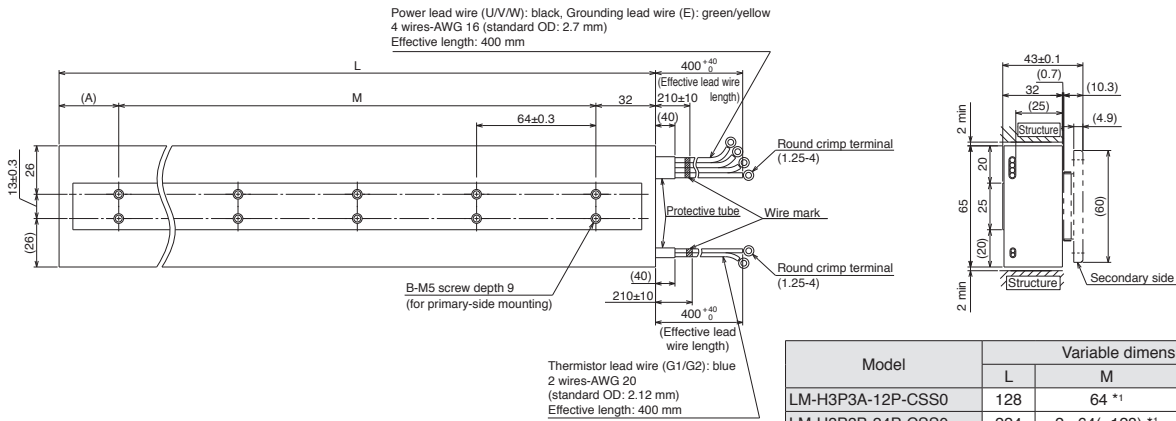

Model	Variable dimensions			
	L	M	A	B
LM-H3P3A-12P-CSS0	128	64 <sup>*1</sup>	32	4
LM-H3P3B-24P-CSS0	224	2×64(=128) <sup>*1</sup>	64	6
LM-H3P3C-36P-CSS0	320	4×64(=256) <sup>*1</sup>	32	10
LM-H3P3D-48P-CSS0	416	5×64(=320) <sup>*1</sup>	64	12

\*1. Pitch tolerance between holes at both ends: ±0.3 [Unit: mm]

### ●LM-H3P7A-24P-ASS0

### ●LM-H3P7B-48P-ASS0

### ●LM-H3P7C-72P-ASS0

### ●LM-H3P7D-96P-ASS0

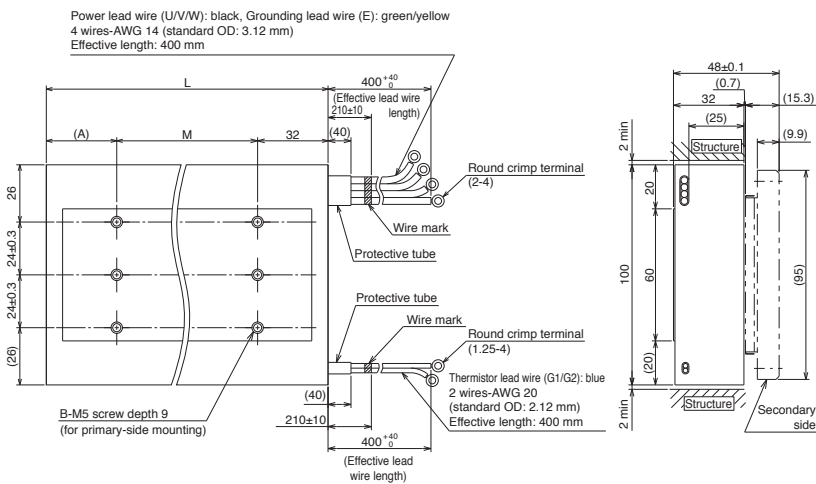

Model	Variable dimensions			
	L	M	A	B
LM-H3P7A-24P-ASS0	128	64 <sup>*1</sup>	32	6
LM-H3P7B-48P-ASS0	224	2×64(=128) <sup>*1</sup>	64	9
LM-H3P7C-72P-ASS0	320	4×64(=256) <sup>*1</sup>	32	15
LM-H3P7D-96P-ASS0	416	5×64(=320) <sup>*1</sup>	64	18

\*1. Pitch tolerance between holes at both ends: ±0.3 [Unit: mm]

Notes: 1. Power, grounding and thermistor lead wires do not have a long bending life. Fix the lead wires led from the primary side (coil) to a moving part to prevent the lead wires from repetitive bending.

2. Minimum bending radius of the lead wire equals to six times the standard overall diameter of the lead wire.

LM-H3 Series Secondary Side (Magnet) Dimensions

- LM-H3S20-288-BSS0
- LM-H3S20-384-BSS0
- LM-H3S20-480-BSS0
- LM-H3S20-768-BSS0

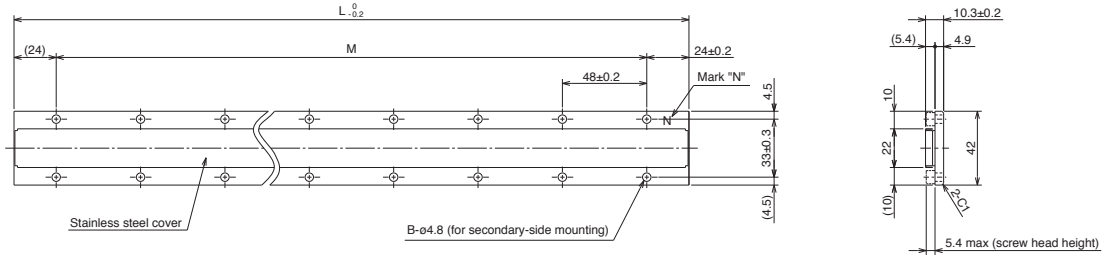

Model	Variable dimensions		
	L	M	B
LM-H3S20-288-BSS0	288	5× 48(=240) *1	12
LM-H3S20-384-BSS0	384	7× 48(=336) *1	16
LM-H3S20-480-BSS0	480	9× 48(=432) *1	20
LM-H3S20-768-BSS0	768	15× 48(=720) *1	32

\*1. Pitch tolerance between holes at both ends: ±0.2 [Unit: mm]

- LM-H3S30-288-CSS0
- LM-H3S30-384-CSS0
- LM-H3S30-480-CSS0
- LM-H3S30-768-CSS0

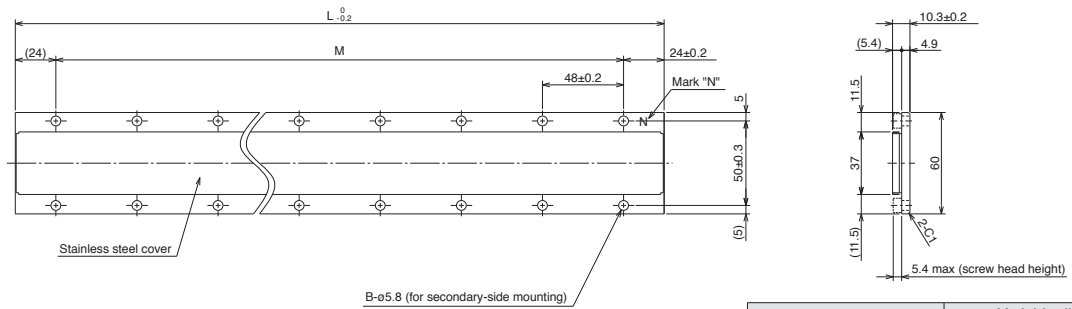

Model	Variable dimensions		
	L	M	B
LM-H3S30-288-CSS0	288	5× 48(=240) *1	12
LM-H3S30-384-CSS0	384	7× 48(=336) *1	16
LM-H3S30-480-CSS0	480	9× 48(=432) *1	20
LM-H3S30-768-CSS0	768	15× 48(=720) *1	32

\*1. Pitch tolerance between holes at both ends: ±0.2 [Unit: mm]

- LM-H3S70-288-ASS0
- LM-H3S70-384-ASS0
- LM-H3S70-480-ASS0
- LM-H3S70-768-ASS0

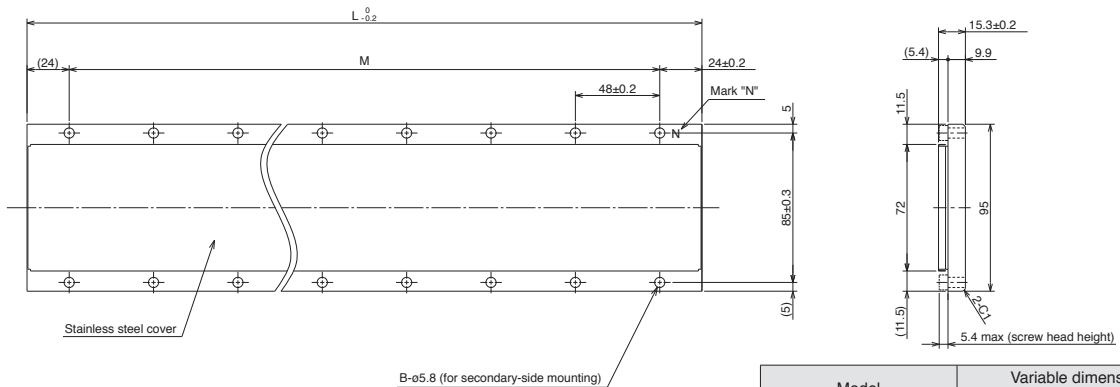

Model	Variable dimensions		
	L	M	B
LM-H3S70-288-ASS0	288	5× 48(=240) *1	12
LM-H3S70-384-ASS0	384	7× 48(=336) *1	16
LM-H3S70-480-ASS0	480	9× 48(=432) *1	20
LM-H3S70-768-ASS0	768	15× 48(=720) *1	32

\*1. Pitch tolerance between holes at both ends: ±0.2 [Unit: mm]

Servo Amplifiers

Rotary Servo Motors

Linear Servo Motors

Direct Drive Motors

Options/Peripheral Equipment

LVS/Wires

Product List

Precautions

# Linear Servo Motors

## LM-F Series Primary Side (Coil) Dimensions (Note 1, 2)

- LM-FP2B-06M-1SS0
- LM-FP2D-12M-1SS0
- LM-FP2F-18M-1SS0

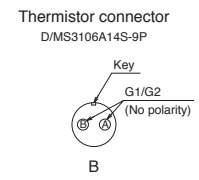
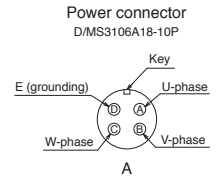
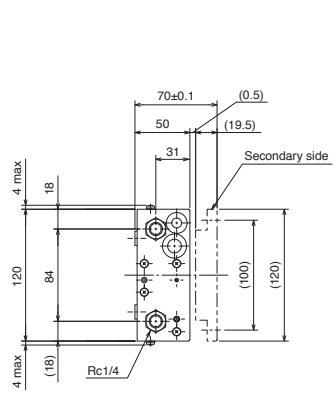
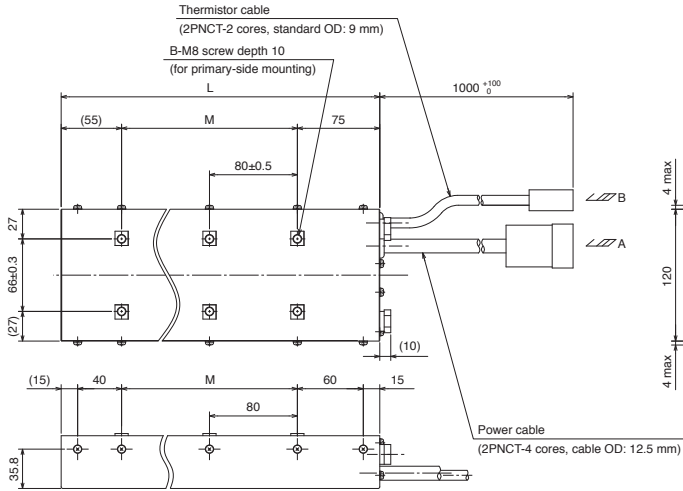

Model	Variable dimensions		
	L	M	B
LM-FP2B-06M-1SS0	290	2 × 80(=160) *1	6
LM-FP2D-12M-1SS0	530	5 × 80(=400) *1	12
LM-FP2F-18M-1SS0	770	8 × 80(=640) *1	18

\*1. Pitch tolerance between holes at both ends: ±0.5 [Unit: mm]

- LM-FP4B-12M-1SS0
- LM-FP4D-24M-1SS0
- LM-FP4F-36M-1SS0
- LM-FP4H-48M-1SS0

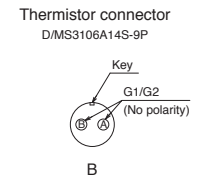
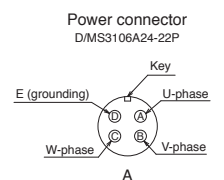
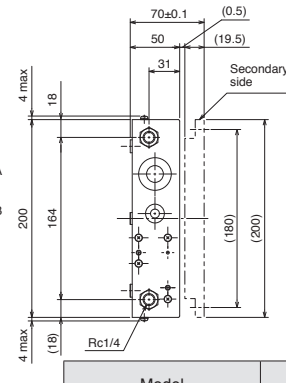
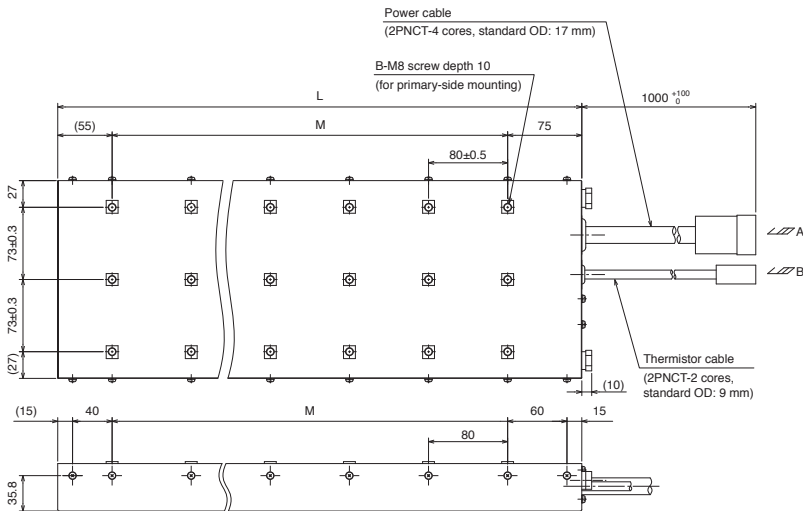

Model	Variable dimensions		
	L	M	B
LM-FP4B-12M-1SS0	290	2 × 80(=160) *1	9
LM-FP4D-24M-1SS0	530	5 × 80(=400) *1	18
LM-FP4F-36M-1SS0	770	8 × 80(=640) *1	27
LM-FP4H-48M-1SS0	1010	11 × 80(=880) *1	36

\*1. Pitch tolerance between holes at both ends: ±0.5 [Unit: mm]

- LM-FP5H-60M-1SS0

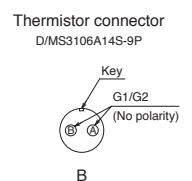
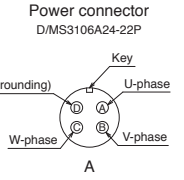
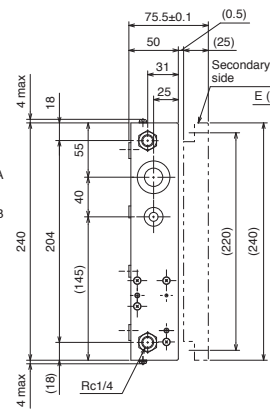
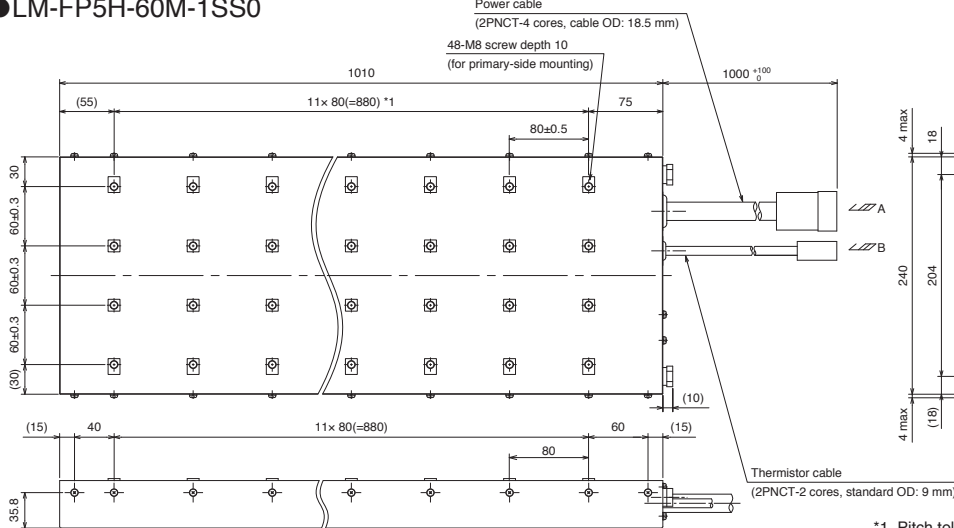

\*1. Pitch tolerance between holes at both ends: ±0.5 [Unit: mm]

Notes: 1. Power and thermistor cables do not have a long bending life. Fix the cables led from the primary side (coil) to a moving part to prevent the cables from repetitive bending.  
2. Minimum bending radius of the cable equals to six times the standard overall diameter of the cable.

LM-F Series Secondary Side (Magnet) Dimensions

- LM-FS20-480-1SS0      ●LM-FS20-576-1SS0

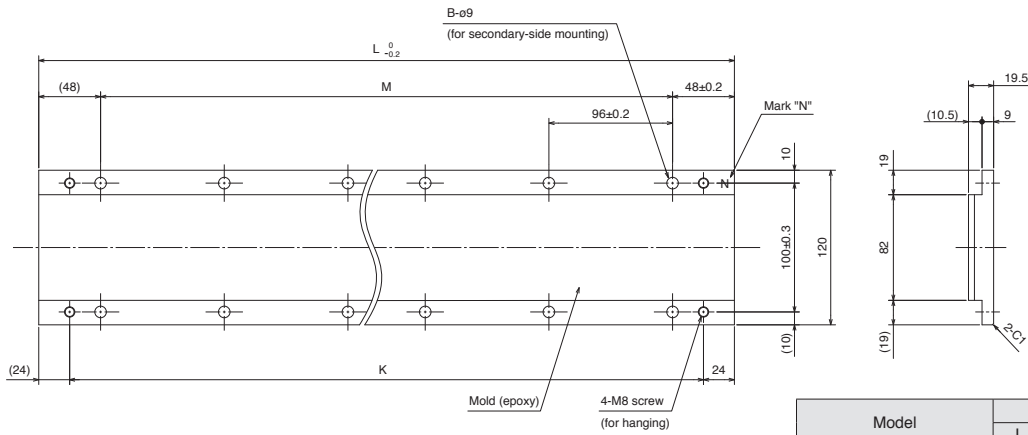

Model	Variable dimensions			
	L	M	B	K
LM-FS20-480-1SS0	480	4 × 96(=384) *1	10	432
LM-FS20-576-1SS0	576	5 × 96(=480) *1	12	528

\*1. Pitch tolerance between holes at both ends: ±0.2 [Unit: mm]

- LM-FS40-480-1SS0      ●LM-FS40-576-1SS0

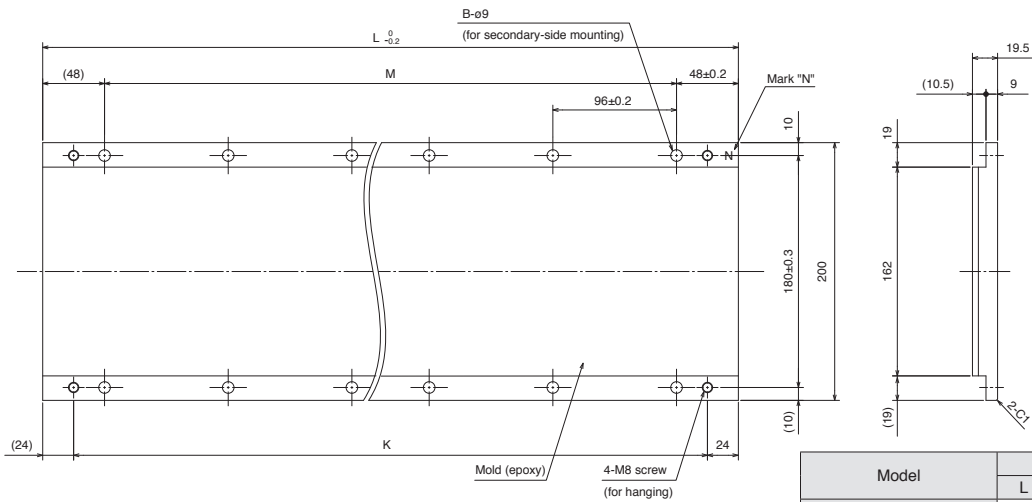

Model	Variable dimensions			
	L	M	B	K
LM-FS40-480-1SS0	480	4 × 96(=384) *1	10	432
LM-FS40-576-1SS0	576	5 × 96(=480) *1	12	528

\*1. Pitch tolerance between holes at both ends: ±0.2 [Unit: mm]

- LM-FS50-480-1SS0      ●LM-FS50-576-1SS0

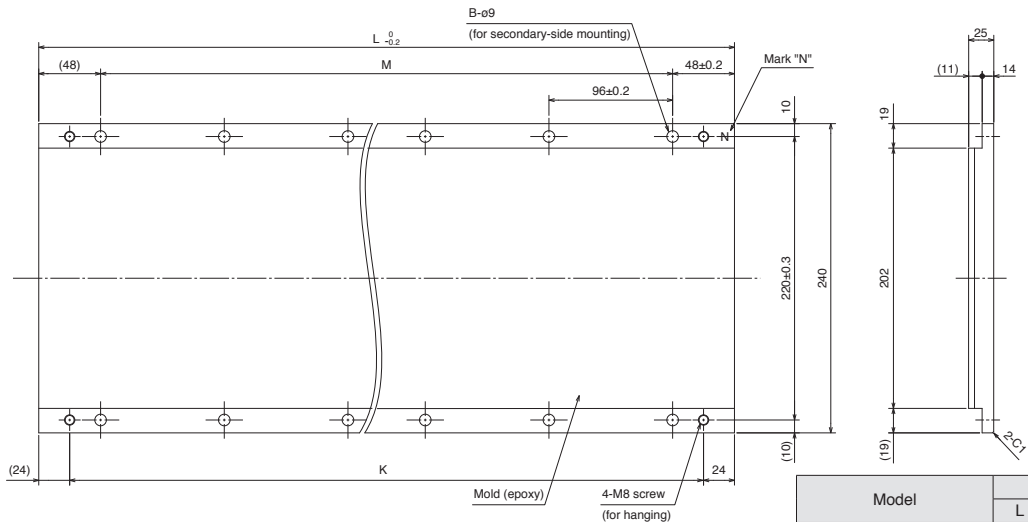

Model	Variable dimensions			
	L	M	B	K
LM-FS50-480-1SS0	480	4 × 96(=384) *1	10	432
LM-FS50-576-1SS0	576	5 × 96(=480) *1	12	528

\*1. Pitch tolerance between holes at both ends: ±0.2 [Unit: mm]

Servo Amplifiers  
 Rotary Servo Motors  
 Linear Servo Motors  
 Direct Drive Motors  
 Options/Peripheral Equipment  
 LV5/Wires  
 Product List  
 Precautions

# Linear Servo Motors

## LM-K2 Series Primary Side (Coil) Dimensions (Note 1, 2)

### ●LM-K2P1A-01M-2SS1

### ●LM-K2P1C-03M-2SS1

Power lead wire (U/V/W): black, Grounding lead wire (E): green/yellow  
Effective length: 300 mm

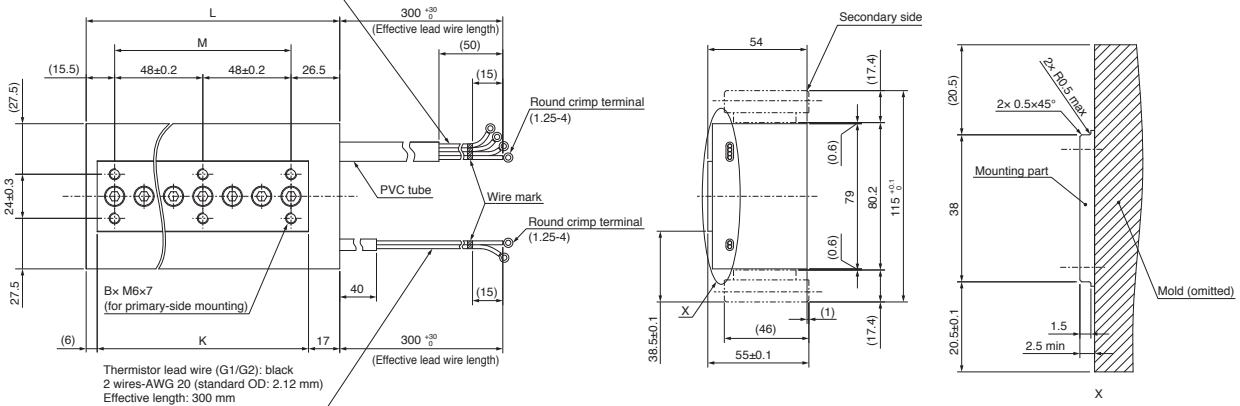

Model	Variable dimensions				Power/grounding lead wire	
	L	M	K	B	Size	Standard OD
LM-K2P1A-01M-2SS1	138	2x 48(=96) *1	115	6	4 wires-AWG 20	2.12
LM-K2P1C-03M-2SS1	330	6x 48(=288) *1	307	14	4 wires-AWG 16	2.7

\*1. Pitch tolerance between holes at both ends: ±0.3

[Unit: mm]

### ●LM-K2P2A-02M-1SS1

### ●LM-K2P2C-07M-1SS1

### ●LM-K2P2E-12M-1SS1

Power lead wire (U/V/W): black, Grounding lead wire (E): green/yellow  
Effective length: 300 mm

Round crimp terminal  
(LM-K2P2A-02M-1SS1: 1.25-4)  
(LM-K2P2C-07M-1SS1, LM-K2P2E-12M-1SS1: 2-4)

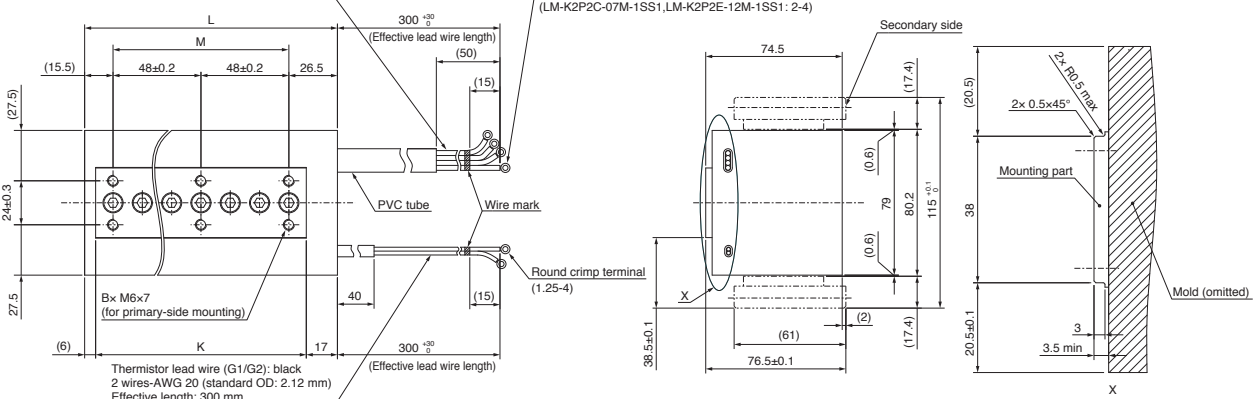

Model	Variable dimensions				Power/grounding lead wire	
	L	M	K	B	Size	Standard OD
LM-K2P2A-02M-1SS1	138	2x 48(=96) *1	115	6	4 wires-AWG 16	2.7
LM-K2P2C-07M-1SS1	330	6x 48(=288) *1	307	14	4 wires-AWG 14	3.12
LM-K2P2E-12M-1SS1	522	10x 48(=480) *1	499	22		

\*1. Pitch tolerance between holes at both ends: ±0.3

[Unit: mm]

### ●LM-K2P3C-14M-1SS1

### ●LM-K2P3E-24M-1SS1

Power lead wire (U/V/W): black, Grounding lead wire (E): green/yellow  
Effective length: 300 mm

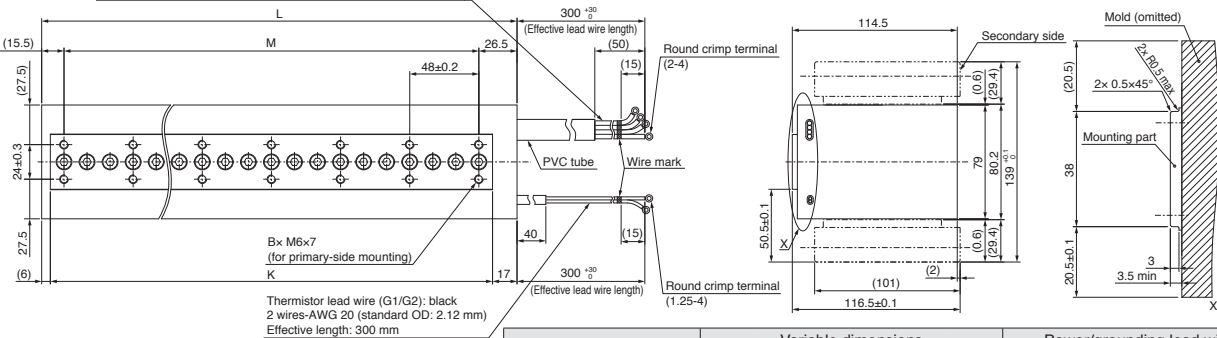

Model	Variable dimensions				Power/grounding lead wire	
	L	M	K	B	Size	Standard OD
LM-K2P3C-14M-1SS1	330	6x 48(=288) *1	307	14	4 wires-AWG 14	3.12
LM-K2P3E-24M-1SS1	522	10x 48(=480) *1	499	22		

\*1. Pitch tolerance between holes at both ends: ±0.3

[Unit: mm]

Notes: 1. Power, grounding and thermistor lead wires do not have a long bending life. Fix the lead wires led from the primary side (coil) to a moving part to prevent the lead wires from repetitive bending.

2. Minimum bending radius of the lead wire equals to six times the standard overall diameter of the lead wire.



**LM-K2 Series Secondary Side (Magnet) Dimensions**

- LM-K2S10-288-2SS1**
- LM-K2S10-384-2SS1**
- LM-K2S10-480-2SS1**
- LM-K2S10-768-2SS1**

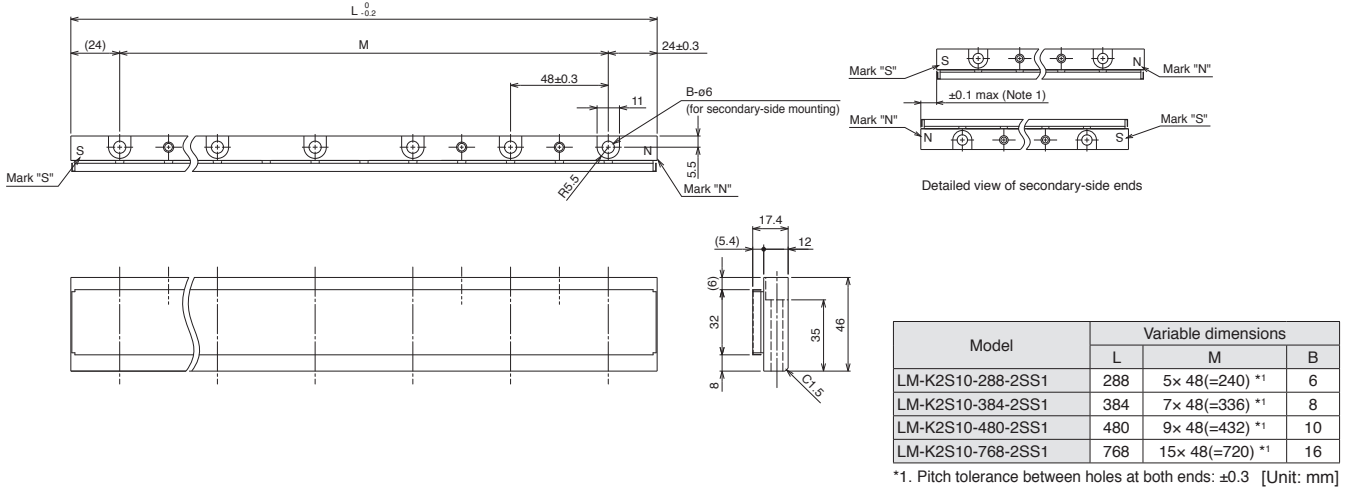

- LM-K2S20-288-1SS1**
- LM-K2S20-384-1SS1**
- LM-K2S20-480-1SS1**
- LM-K2S20-768-1SS1**

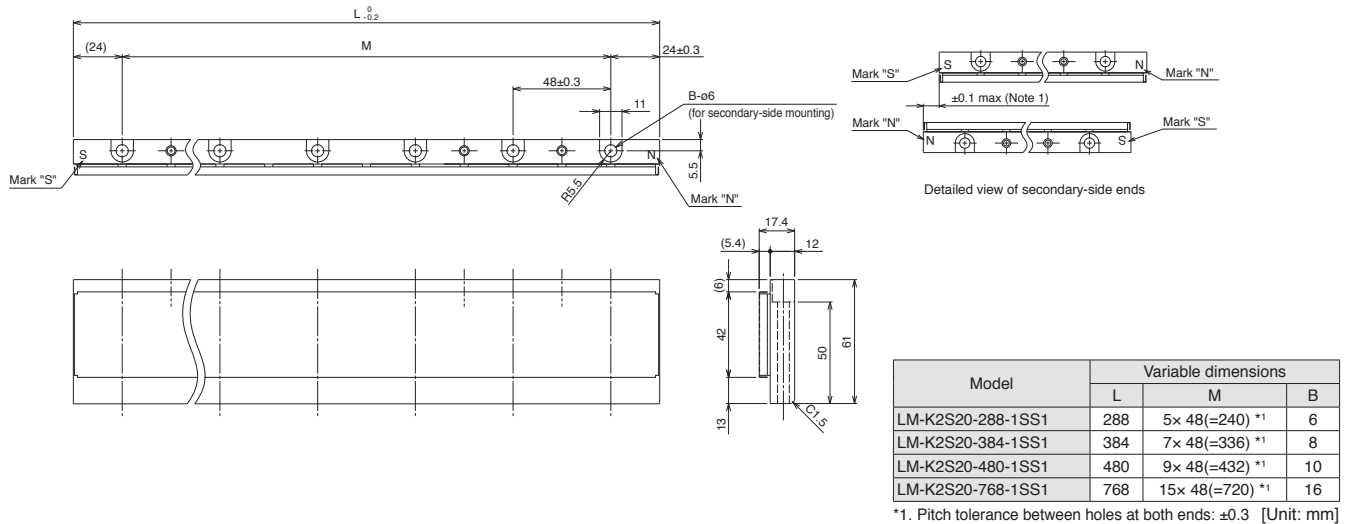

- LM-K2S30-288-1SS1**
- LM-K2S30-384-1SS1**
- LM-K2S30-480-1SS1**
- LM-K2S30-768-1SS1**

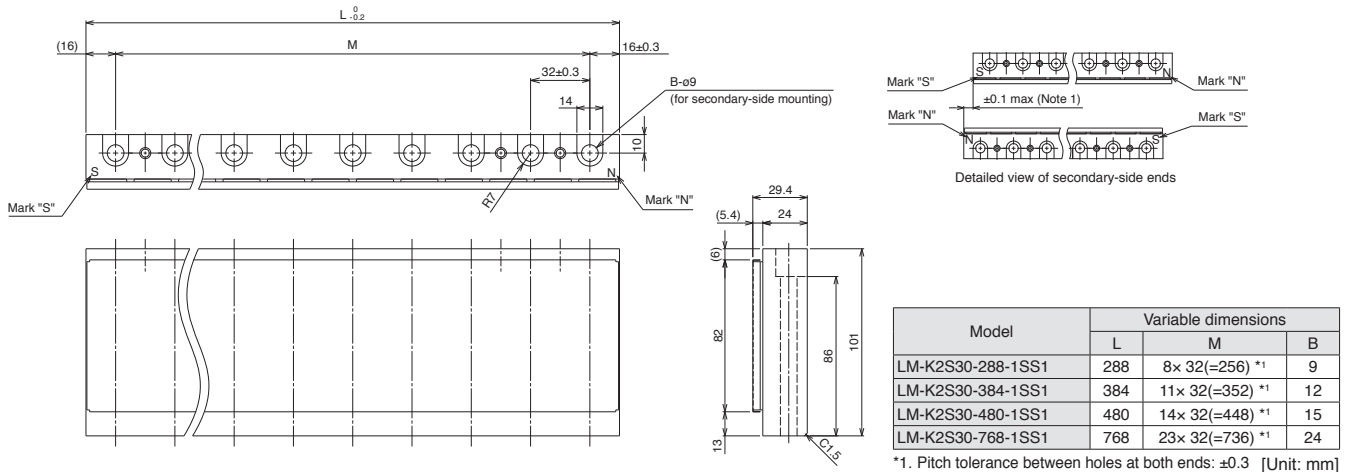

Notes: 1. Longitudinal deviation of the secondary side must be within ±0.1 mm.

Servo Amplifiers

Rotary Servo Motors

Linear Servo Motors

Direct Drive Motors

Options/Peripheral Equipment

LVS/Wires

Product List

Precautions

# Linear Servo Motors

## LM-U2 Series Primary Side (Coil) Dimensions (Note 1, 2)

### ●LM-U2PAB-05M-0SS0

### ●LM-U2PAD-10M-0SS0

### ●LM-U2PAF-15M-0SS0

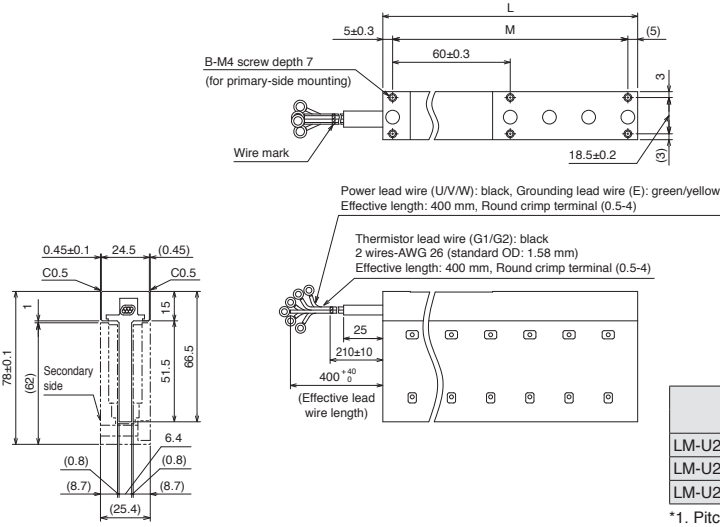

### ●LM-U2PBB-07M-1SS0

### ●LM-U2PBD-15M-1SS0

### ●LM-U2PBF-22M-1SS0

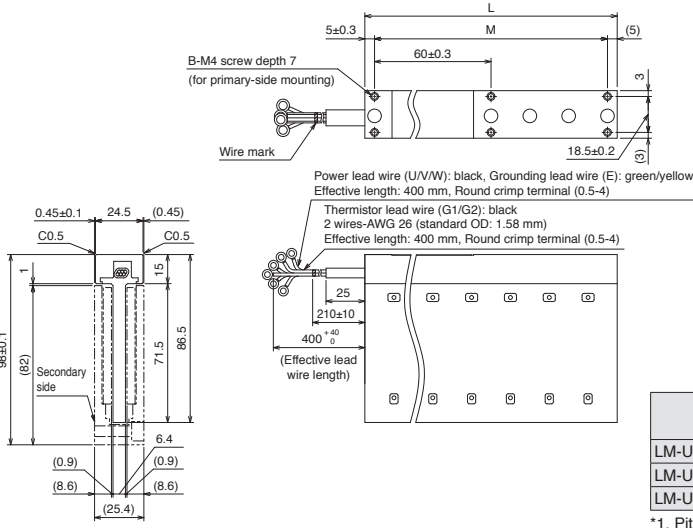

### ●LM-U2P2B-40M-2SS0

### ●LM-U2P2C-60M-2SS0

### ●LM-U2P2D-80M-2SS0

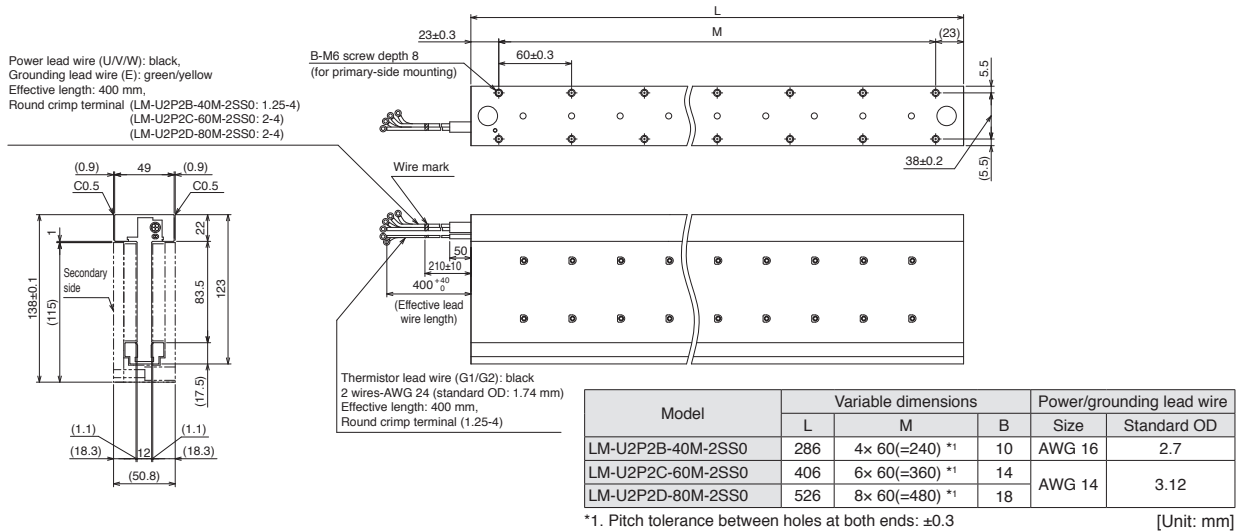

Notes: 1. Power, grounding and thermistor lead wires do not have a long bending life. Fix the lead wires led from the primary side (coil) to a moving part to prevent the lead wires from repetitive bending.

2. Minimum bending radius of the lead wire equals to six times the standard overall diameter of the lead wire.

LM-U2 Series Secondary Side (Magnet) Dimensions

- LM-U2SA0-240-0SS0
- LM-U2SA0-300-0SS0
- LM-U2SA0-420-0SS0

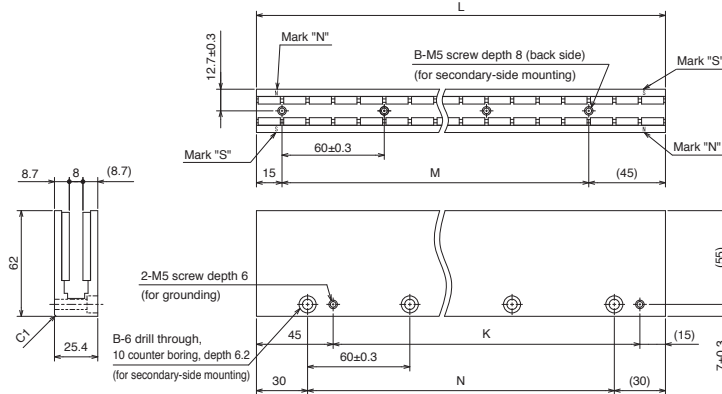

Model	Variable dimensions				
	L	M	B	K	N
LM-U2SA0-240-0SS0	240	3× 60(=180) *1	4	180	3× 60(=180) *1
LM-U2SA0-300-0SS0	300	4× 60(=240) *1	5	240	4× 60(=240) *1
LM-U2SA0-420-0SS0	420	6× 60(=360) *1	7	360	6× 60(=360) *1

\*1. Pitch tolerance between holes at both ends: ±0.3 [Unit: mm]

- LM-U2SB0-240-1SS1
- LM-U2SB0-300-1SS1
- LM-U2SB0-420-1SS1

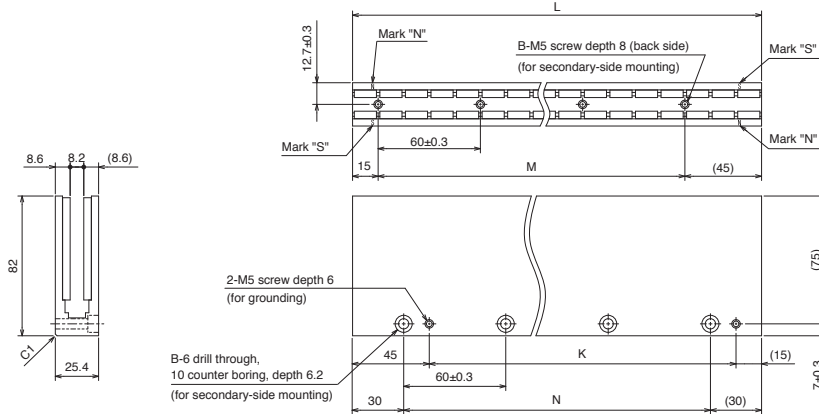

Model	Variable dimensions				
	L	M	B	K	N
LM-U2SB0-240-1SS1	240	3× 60(=180) *1	4	180	3× 60(=180) *1
LM-U2SB0-300-1SS1	300	4× 60(=240) *1	5	240	4× 60(=240) *1
LM-U2SB0-420-1SS1	420	6× 60(=360) *1	7	360	6× 60(=360) *1

\*1. Pitch tolerance between holes at both ends: ±0.3 [Unit: mm]

- LM-U2S20-300-2SS1
- LM-U2S20-480-2SS1

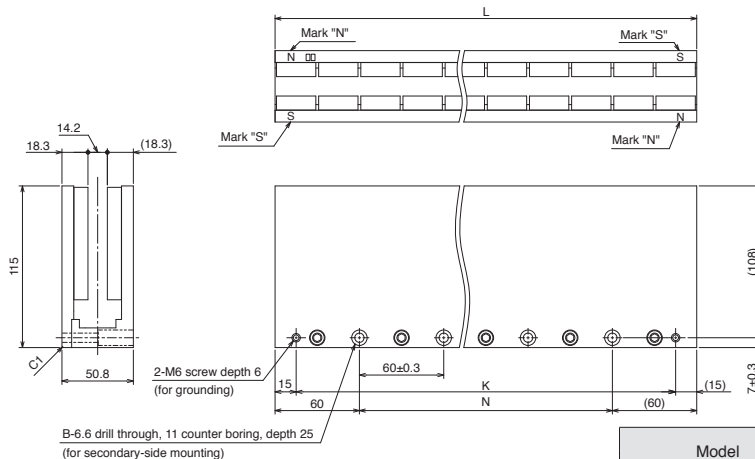

Model	Variable dimensions			
	L	N	B	K
LM-U2S20-300-2SS1	300	3× 60(=180) *1	4	270
LM-U2S20-480-2SS1	480	6× 60(=360) *1	7	450

\*1. Pitch tolerance between holes at both ends: ±0.3 [Unit: mm]

Servo Amplifiers  
Rotary Servo Motors  
Linear Servo Motors  
Direct Drive Motors  
Options/Peripheral Equipment  
LV/S/Wires  
Product List  
Precautions

# Linear Servo Motors

## List of Linear Encoders <sup>(Note 1)</sup>

Contact your local sales office for compatible linear encoders.

### Mitsubishi Electric high-speed serial communication-compatible absolute type

Manufacturer	Model	Resolution	Rated speed <sup>(Note 2)</sup>	Maximum effective measurement length <sup>(Note 3)</sup>	Communication method
Magnescale Co., Ltd.	SR77	0.05 μm/	3.3 m/s	2040 mm	Two-wire type
	SR87	0.01 μm		3040 mm	
	SR27A	0.01 μm	3.3 m/s	2040 mm	Two-wire type/ Four-wire type <sup>(Note 4)</sup>
	SR67A			3640 mm	
	SmartSCALE SQ47	0.005 μm	3.3 m/s	3740 mm	
	SmartSCALE SQ57			3770 mm	
Mitutoyo Corporation	AT343A	0.05 μm	2.0 m/s	3000 mm	Two-wire type
	AT543A-SC		2.5 m/s	2200 mm	
	AT545A-SC	20 μm/4096 (Approx. 0.005 μm)	2.5 m/s	2200 mm	
	ST743A	0.1 μm	5.0 m/s	6000 mm	
	ST744A				
	ST748A				
	ST1341A	0.01 μm	8.0 m/s	12000 mm	
ST1342A	0.001 μm	4200 mm			
Renishaw	RESOLUTE RL40M	1 nm	100 m/s	2100 mm	Two-wire type
		50 nm		20990 mm	
	EVOLUTE EL40M	50 nm/100 nm/500 nm	100 m/s	10010 mm	
Heidenhain	LC 495M	0.001 μm/	3.0 m/s	2040 mm	Four-wire type <sup>(Note 4)</sup>
	LC 195M	0.01 μm		4240 mm	
	LIC 4193M	0.005 μm/ 0.01 μm	10.0 m/s	3040 mm	Two-wire type/ Four-wire type <sup>(Note 4)</sup>
	LIC 4195M			28440 mm	
	LIC 4197M			6040 mm	
	LIC 4199M	1020 mm			
	LIC 2197M	0.05 μm/	10.0 m/s	6020 mm	
LIC 2199M	0.1 μm	6020 mm			
RSF Elektronik	MC15M	0.05 μm/ 0.1 μm	10.0 m/s	3020 mm	

Notes: 1. Contact the relevant linear encoder manufacturer for details on operating environment and specifications of the linear encoder such as ambient temperature, vibration resistance and IP rating.

2. The listed values are the manufacturer's specifications. When combined with MR-J4-\_- servo amplifiers, the specification value is either the listed value or the servo motor maximum speed, whichever is lower.

3. The listed values are the manufacturer's specifications. The maximum length of the encoder cable between a linear encoder and a servo amplifier is 30 m.

4. When using the four-wire type linear encoder in the fully closed loop control, use MR-J4-\_GF\_-RJ/MR-J4-\_B\_-RJ/MR-J4-\_A\_-RJ servo amplifier. When using four-wire type linear encoder with the scale measurement function, use MR-J4-\_GF\_-RJ/MR-J4-\_B\_-RJ servo amplifier.

**List of Linear Encoders** (Note 1)

Contact your local sales office for compatible linear encoders.

Mitsubishi Electric high-speed serial communication-compatible incremental type

Manufacturer	Model	Resolution	Rated speed (Note 2)	Maximum effective measurement length (Note 3)	Communication method
Magnescale Co., Ltd.	SR75	0.05 μm/	3.3 m/s	2040 mm	Two-wire type
	SR85	0.01 μm		3040 mm	
	SL710 + PL101-RM/RHM	0.1 μm	10.0 m/s	100000 mm	Two-wire type/ Four-wire type (Note 6)
	SQ10 + PQ10 + MQ10	0.1 μm/ 0.05 μm	10.0 m/s	3800 mm	
Heidenhain	LIDA 483 + EIB 3091M (16384-fold subdivision) (Note 7)	20 μm/16384 (Approx. 1.22 nm)	4.0 m/s	3040 mm	Four-wire type (Note 6)
	LIDA 485 + EIB 3091M (16384-fold subdivision) (Note 7)			30040 mm	
	LIDA 487 + EIB 3091M (16384-fold subdivision) (Note 7)			6040 mm	
	LIDA 489 + EIB 3091M (16384-fold subdivision) (Note 7)			1020 mm	
	LIDA 287 + EIB 3091M (16384-fold subdivision) (Note 7)	200 μm/16384 (Approx. 12.2 nm)	1.6 m/s	10000 mm	
	LIDA 289 + EIB 3091M (16384-fold subdivision) (Note 7)			1020 mm	
	LIF 481 + EIB 3091M (4096-fold subdivision)	4 μm/4096 (Approx. 0.977 nm)	1.6 m/s	1440 mm	
	LIP 6081 + EIB 3091M (4096-fold subdivision)			1440 mm	
Nidec Instruments Corporation	PSLH041 (Note 8)	0.1 μm	5.0 m/s	2400 mm	Two-wire type

**A/B/Z-phase differential output type** (Note 4, 9)

Manufacturer	Model	Resolution	Rated speed (Note 2)	Maximum effective measurement length (Note 3)	Communication method
Not designated	-	0.001 μm to 5 μm (Note 5)	Depends on the linear encoder	Depends on the linear encoder	A/B/Z-phase differential output method

- Notes: 1. Contact the relevant linear encoder manufacturer for details on operating environment and specifications of the linear encoder such as ambient temperature, vibration resistance and IP rating.  
 2. The listed values are the manufacturer's specifications. When combined with MR-J4-\_- servo amplifiers, the specification value is either the listed value or the servo motor maximum speed, whichever is lower.  
 3. The listed values are the manufacturer's specifications. The maximum length of the encoder cable between a linear encoder and a servo amplifier is 30 m.  
 4. When using the A/B/Z-phase differential output type linear encoder, use MR-J4-\_-GF\_-RJ/MR-J4-\_-B\_-RJ/MR-J4-\_-A\_-RJ servo amplifier.  
 5. Select the linear encoder within this range.  
 6. When using the four-wire type linear encoder in the fully closed loop control, use MR-J4-\_-GF\_-RJ/MR-J4-\_-B\_-RJ/MR-J4-\_-A\_-RJ servo amplifier. When using four-wire type linear encoder with the scale measurement function, use MR-J4-\_-GF\_-RJ/MR-J4-\_-B\_-RJ servo amplifier.  
 7. For this combination, it is recommended using EIB 3091M with a subdivision of 16384. EIB 3091M with a subdivision of 4096 is also available. For details, contact the manufacturer.  
 8. Use MR-J4-\_-B\_-(-RJ)/MR-J4W\_-\_-B/MR-J4-\_-A\_-(-RJ) servo amplifier with software version B3 or later.  
 9. The phase difference of the A-phase pulse and the B-phase pulse, and the width of the Z-phase pulse must be 200 ns or wider. The output pulse of A-phase and B-phase of the A/B/Z-phase differential output linear encoder is in the multiply-by-four count method. For linear encoders without Z-phase, some of the homing modes cannot be used. Refer to "Linear Servo Motor Instruction Manual" for details.

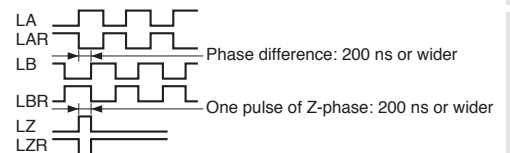

# Linear Servo Motors

## Selecting Linear Servo Motor

- Linear servo motor must be selected according to the purpose of the application.  
Select the optimal linear servo motor after completely understanding the characteristics of the guides, the linear encoders and the linear servo motors.
- The maximum speed of LM-H3 series is 3.0 m/s and of LM-F, LM-K2 and LM-U2 series is 2.0 m/s.  
Note that the maximum speed may not be reached, depending on the selected linear encoder.

## Linear Servo Motor Sizing Example

- In order to select a suitable linear servo motor, it is necessary to calculate the maximum thrust required during acceleration/deceleration and the continuous effective load thrust according to the machine specifications and the operating patterns. Here the linear servo motor is selected according to linear acceleration/deceleration operating patterns.

### 1. Selection criteria

#### (1) Configurations

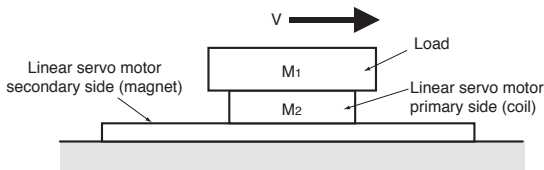

Load mass	$M_1 = 20 \text{ kg}$
Linear servo motor primary-side (coil) mass (Determined after the motor is selected.)	$M_2 = \text{ kg}$
Acceleration	$a = 14.4 \text{ m/s}^2$
Deceleration	$d = 14.4 \text{ m/s}^2$
Resistive force (including friction, unbalance and cable chain) (Determined after the motor is selected.)	$F_f = \text{ N}$
Feed speed	$V = 1.8 \text{ m/s}$
Operating cycle	$t_0 = 2 \text{ s}$
Acceleration time	$t_1 = 0.125 \text{ s}$
Constant velocity time	$t_2 = 0.75 \text{ s}$
Deceleration time	$t_3 = 0.125 \text{ s}$
Mechanical efficiency	$\eta = 1.0$
Friction coefficient	$\mu = 0.020 \text{ (for iron)}$

#### (2) Operating pattern

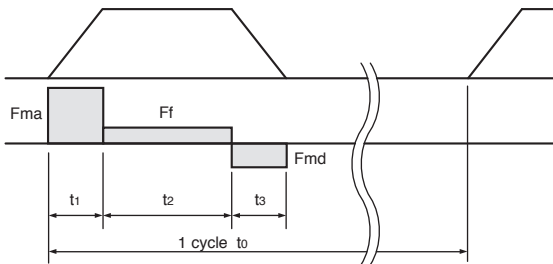

### 2. Method of selecting linear servo motor (theoretical value)

#### (1) Select a linear servo motor

From the linear servo motor series that is suitable for your application or machine, select a linear servo motor with the mass ratio of load to primary side (coil) which is equal to or less than the recommended load to motor mass ratio.

For LM-H3 series: 35 times <sup>(Note 1)</sup>  $\geq M_1/M_2$

Select linear servo motors that satisfy the above formula, e.g., LM-H3P2A-07P-BSS0, LM-H3P3A-12P-CSS0, and LM-H3P3B-24P-CSS0.

Calculate thrusts during acceleration and deceleration, and continuous effective load thrust for each linear servo motor selected in (1).

The following is an example of calculation for LM-H3P3B-24P-CSS0.

#### (2) Calculate necessary thrust

Resistive force

$$M = M_1 + M_2 = 22.3 \text{ kg}$$

$$F_f = \mu \cdot (M \cdot 9.8 + \text{Magnetic attraction force [N]}) \text{ (when considering friction only)} = 48.4 \text{ N}$$

Thrust during acceleration and deceleration

$$F_{ma} = M \cdot a + F_f = 369.5 \text{ N}$$

$$F_{md} = -M \cdot d + F_f = -272.7 \text{ N}$$

Continuous effective load thrust

$$F_{rms} = \sqrt{(F_{ma}^2 \cdot t_1 + F_f^2 \cdot t_2 + F_{md}^2 \cdot t_3) / t_0} = 118.6 \text{ N}$$

#### (3) Verify the selected linear servo motor.

$$F_{rms}/\eta \leq \text{Continuous thrust [N] of the selected linear servo motor}$$

$$F_{ma}/\eta \leq \text{Maximum thrust [N] of the selected linear servo motor}$$

If the above criteria are not satisfied, select one rank larger capacity linear servo motor and recalculate.

#### (4) Result

Select the following:

Linear servo motor: LM-H3P3B-24P-CSS0

Servo amplifier: MR-J4-70B

Notes: 1. The ratio of 35 times is applicable for LM-H3 series. Select a linear servo motor with the mass ratio of 30 times or less for LM-K2 or LM-U2 series, and 15 times or less for LM-F series.

[Drive System Sizing Software Motorizer]

Motorizer does all the calculations for you. Contact your local sales office for more details.

3. Determining the number of the secondary-side (magnet) blocks

The number of the secondary-side (magnet) blocks is determined according to the total distance calculated from the following equation (Note 2) :

$$(\text{Total length of aligned secondary side (magnet)}) \geq (\text{Maximum feed distance}) + (\text{Length of the primary side (coil)})$$

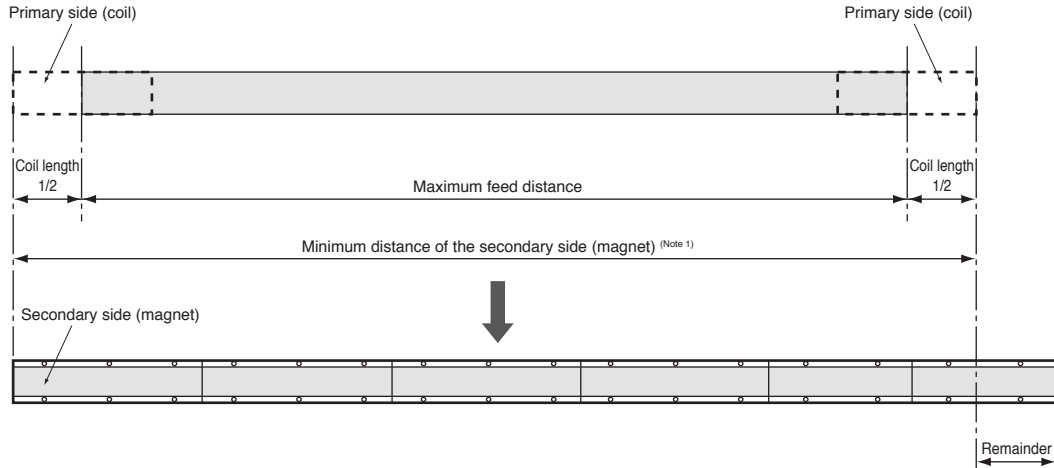

- Notes: 1. Pitch tolerance between any two holes must be within ±0.2 mm. When two or more secondary sides (magnets) are aligned, spaces may exist between each secondary side (magnet) block, depending on the mounting method and the number of the secondary-side blocks.
- 2. LM-K2 series has a structure of magnetic attraction counter-force and requires at least two blocks of identical secondary side (magnet). Therefore, the total number of the secondary side necessary equals to twice the number determined from the equation.

4. Selecting regenerative option

The following table shows the energy charged into the capacitor of the servo amplifier and the inverse efficiency of the linear servo motor.

The energy consumed by a regenerative resistor is calculated as follows:

$$\text{Regenerative energy } P \text{ [W]} = \{-Fmd \cdot (t_3 \cdot \text{Speed}/2) \cdot (\text{Inverse efficiency}/100) - \text{Capacitor charging}\}/t_0$$

Select a suitable regenerative option as necessary to keep the consumed regenerative energy below the regenerative power shown in the following table:

Servo Amplifier (Note 2)	Capacitor charging [J]	Inverse efficiency [%]	Permissible regenerative power of built-in regenerative resistor [W]	Permissible regenerative power of external regenerative resistor (standard accessory) [W] (Note 4)	Permissible regenerative power of regenerative option [W]											
					MR-RB (Note 3)											
					032	12	30 (Note 5)	3N (Note 5)	31 (Note 5)	32 (Note 5)	50 (Note 1)	5N (Note 1)	51 (Note 1)	5R (Note 4)	9F (Note 4)	6K-4 (Note 4)
MR-J4-20_(-RJ) MR-J4-20_1(-RJ)	9	75	10	-	30	100	-	-	-	-	-	-	-	-	-	-
MR-J4-40_(-RJ) MR-J4-40_1(-RJ)	11	85	10	-	30	100	-	-	-	-	-	-	-	-	-	-
MR-J4-60_(-RJ)	11	85	10	-	30	100	-	-	-	-	-	-	-	-	-	-
MR-J4-70_(-RJ)	18	85	20	-	30	100	-	-	-	300	-	-	-	-	-	-
MR-J4-200_(-RJ)	36	85	100	-	-	-	300	-	-	-	500	-	-	-	-	-
MR-J4-350_(-RJ)	40	85	100	-	-	-	-	300	-	-	-	500	-	-	-	-
MR-J4-500_(-RJ)	45	90	130	-	-	-	-	-	300	-	-	-	500	-	-	-
MR-J4-700_(-RJ)	70	90	170	-	-	-	-	-	300	-	-	-	500	-	-	-
MR-J4-11K_(-RJ)	120	90	-	500 (800)	-	-	-	-	-	-	-	-	-	500 (800)	-	-
MR-J4-15K_(-RJ)	170	90	-	850 (1300)	-	-	-	-	-	-	-	-	-	-	850 (1300)	-
MR-J4-22K_4(-RJ)	250	90	-	850 (1300)	-	-	-	-	-	-	-	-	-	-	-	850 (1300)

- Notes: 1. Be sure to cool the unit forcibly with a cooling fan (92 mm × 92 mm, minimum air flow: 1.0 m<sup>3</sup>/min). The cooling fan must be prepared by user.
- 2. For selecting a regenerative option for MR-J4W\_-B, refer to "MR-J4W2\_-B MR-J4W3\_-B MR-J4W2-0303B6 Servo Amplifier Instruction Manual" for details.
- 3. Refer to "Regenerative Option" in this catalog for details on the regenerative option.
- 4. The value in brackets is applicable when cooling fans (two units of 92 mm × 92 mm, minimum air flow: 1.0 m<sup>3</sup>/min) are installed, and then [Pr. PA02] is changed.
- 5. Depending on the operating environment, it may be necessary to cool the unit forcibly with a cooling fan (92 mm × 92 mm, minimum air flow: 1.0 m<sup>3</sup>/min). Refer to relevant Servo Amplifier Instruction Manual for details. The cooling fan must be prepared by users.

## Linear Servo Motors

MEMO



# 4 Direct Drive Motors

Model Designation.....	4-1
Combinations of Direct Drive Motor and Servo Amplifier .....	4-2
Specifications	
TM-RG2M/TM-RU2M Series .....	4-3
TM-RFM Series .....	4-5
Machine Accuracy .....	4-8
Dimensions	
TM-RG2M Series.....	4-9
TM-RU2M Series.....	4-11
TM-RFM Series .....	4-13
Sizing Example.....	4-15

\* Refer to p. 5-99 in this catalog for conversion of units.

\* The characteristics and numerical values without tolerances mentioned in this catalog are representative values.

# Direct Drive Motors

## Model Designation (Note 1)

### Low-profile series

#### ● Flange type

### T M - R G 2 M

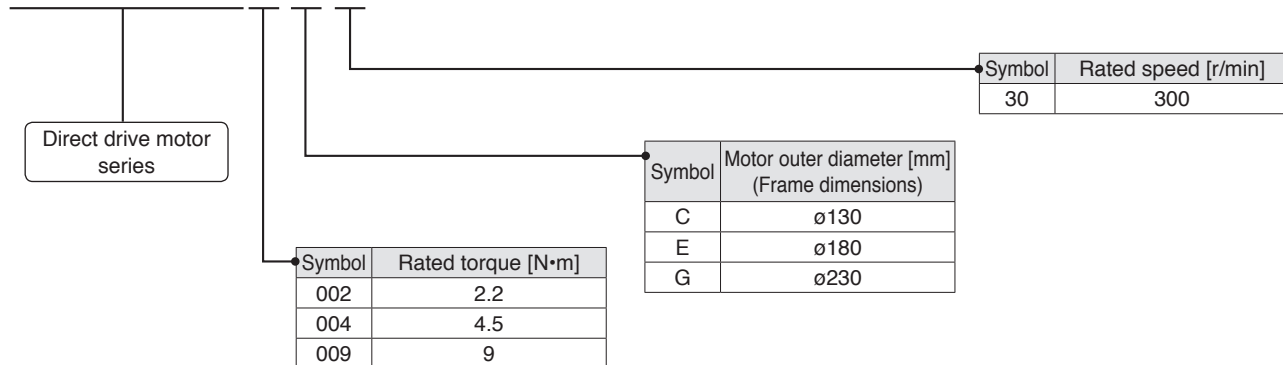

#### ● Table type

### T M - R U 2 M

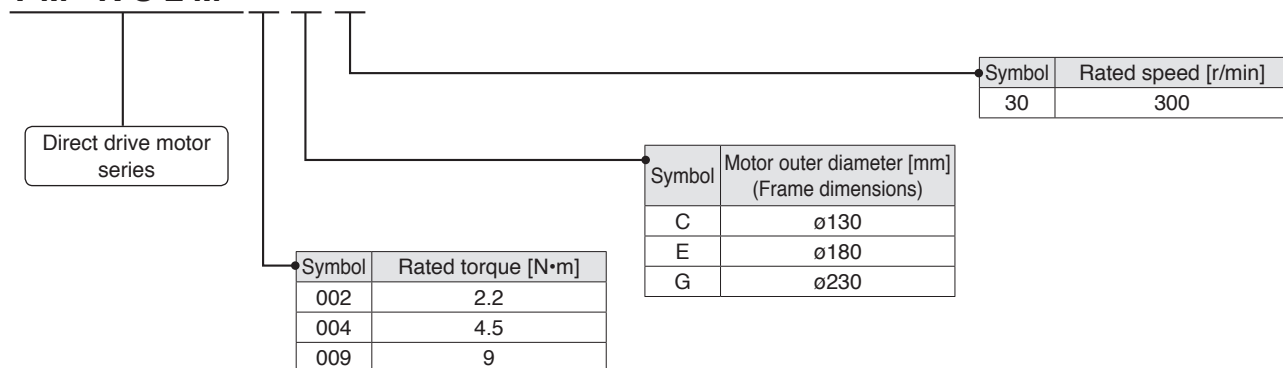

### High-rigidity series

### T M - R F M

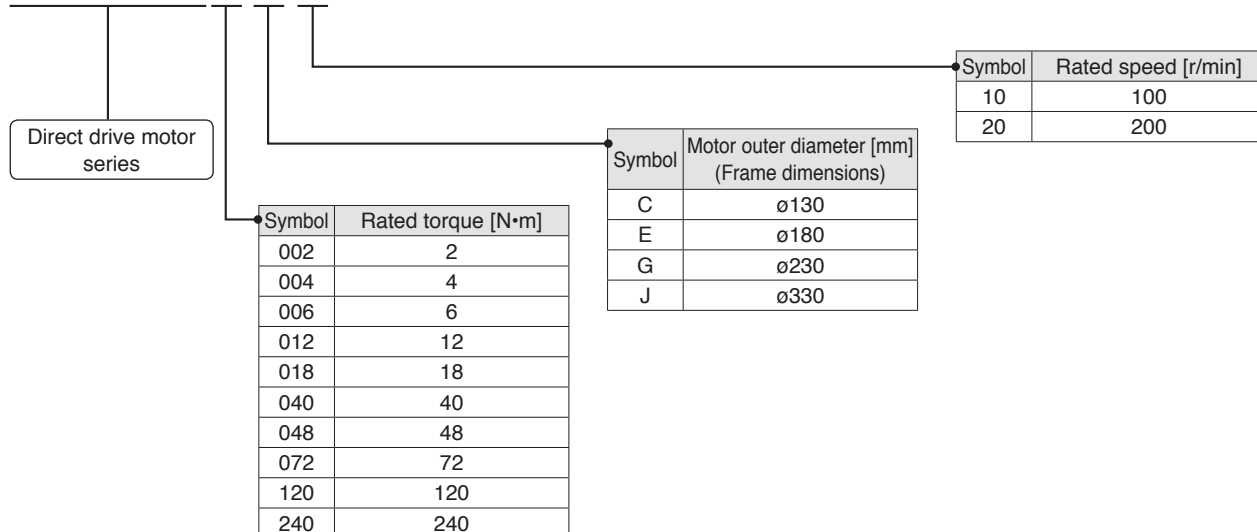

Notes: 1. This section describes what each symbol in a model name indicates. Some combinations of symbols are not available.

Combinations of Direct Drive Motor and Servo Amplifier

Direct drive motor		Servo amplifier		
		MR-J4	MR-J4W2 (Note 1)	MR-J4W3 (Note 1)
TM-RG2M/ TM-RU2M series	TM-RG2M002C30, TM-RU2M002C30	MR-J4-20GF(-RJ), MR-J4-20GF1(-RJ), MR-J4-20B(-RJ) (Note 3), MR-J4-20B1(-RJ) (Note 3), MR-J4-20A(-RJ) (Note 3), MR-J4-20A1(-RJ) (Note 3)	MR-J4W2-22B (Note 3), MR-J4W2-44B (Note 3)	MR-J4W3-222B (Note 3), MR-J4W3-444B (Note 3)
	TM-RG2M004E30, TM-RU2M004E30	MR-J4-20GF(-RJ), MR-J4-20GF1(-RJ), MR-J4-40GF(-RJ) (Note 2), MR-J4-40GF1(-RJ) (Note 2), MR-J4-20B(-RJ) (Note 3), MR-J4-20B1(-RJ) (Note 3), MR-J4-40B(-RJ) (Note 2, 3), MR-J4-40B1(-RJ) (Note 2, 3), MR-J4-20A(-RJ) (Note 3), MR-J4-20A1(-RJ) (Note 3), MR-J4-40A(-RJ) (Note 2, 3), MR-J4-40A1(-RJ) (Note 2, 3)	MR-J4W2-22B (Note 3), MR-J4W2-44B (Note 2, 3)	MR-J4W3-222B (Note 3), MR-J4W3-444B (Note 2, 3)
	TM-RG2M009G30, TM-RU2M009G30	MR-J4-40GF(-RJ), MR-J4-40GF1(-RJ), MR-J4-40B(-RJ) (Note 3), MR-J4-40B1(-RJ) (Note 3), MR-J4-40A(-RJ) (Note 3), MR-J4-40A1(-RJ) (Note 3)	MR-J4W2-44B (Note 3)	MR-J4W3-444B (Note 3)
TM-RFM series	TM-RFM002C20	MR-J4-20GF(-RJ) (Note 4), MR-J4-20GF1(-RJ), MR-J4-20B(-RJ), MR-J4-20B1(-RJ), MR-J4-20A(-RJ), MR-J4-20A1(-RJ)	MR-J4W2-22B, MR-J4W2-44B	MR-J4W3-222B, MR-J4W3-444B
	TM-RFM004C20	MR-J4-40GF(-RJ) (Note 4), MR-J4-40GF1(-RJ), MR-J4-40B(-RJ), MR-J4-40B1(-RJ), MR-J4-40A(-RJ), MR-J4-40A1(-RJ)	MR-J4W2-44B, MR-J4W2-77B, MR-J4W2-1010B	MR-J4W3-444B
	TM-RFM006C20	MR-J4-60GF(-RJ) (Note 4), MR-J4-60B(-RJ), MR-J4-60A(-RJ)	MR-J4W2-77B, MR-J4W2-1010B	-
	TM-RFM006E20	MR-J4-60GF(-RJ) (Note 4), MR-J4-60B(-RJ), MR-J4-60A(-RJ)	MR-J4W2-77B, MR-J4W2-1010B	-
	TM-RFM012E20	MR-J4-70GF(-RJ) (Note 4), MR-J4-70B(-RJ), MR-J4-70A(-RJ)	MR-J4W2-77B, MR-J4W2-1010B	-
	TM-RFM018E20	MR-J4-100GF(-RJ) (Note 4), MR-J4-100B(-RJ), MR-J4-100A(-RJ)	MR-J4W2-1010B	-
	TM-RFM012G20	MR-J4-70GF(-RJ) (Note 4), MR-J4-70B(-RJ), MR-J4-70A(-RJ)	MR-J4W2-77B, MR-J4W2-1010B	-
	TM-RFM048G20	MR-J4-350GF(-RJ) (Note 4), MR-J4-350B(-RJ), MR-J4-350A(-RJ)	-	-
	TM-RFM072G20	MR-J4-350GF(-RJ) (Note 4), MR-J4-350B(-RJ), MR-J4-350A(-RJ)	-	-
	TM-RFM040J10	MR-J4-70GF(-RJ) (Note 4), MR-J4-70B(-RJ), MR-J4-70A(-RJ)	MR-J4W2-77B, MR-J4W2-1010B	-
	TM-RFM120J10	MR-J4-350GF(-RJ) (Note 4), MR-J4-350B(-RJ), MR-J4-350A(-RJ)	-	-
TM-RFM240J10	MR-J4-500GF(-RJ) (Note 4), MR-J4-500B(-RJ), MR-J4-500A(-RJ)	-	-	

Notes: 1. Any combination of the servo motors is available. Refer to "Combinations of Multi-Axis Servo Amplifier and Servo Motors" on p. 1-8 in this catalog.

2. This combination increases the rated and maximum torque.

3. Use the servo amplifiers with software version C8 or later.

4. MR-J4\_G(-RJ) with software version A1 or later supports TM-RFM series direct drive motor.

Servo Amplifiers  
Rotary Servo Motors  
Linear Servo Motors  
Direct Drive Motors  
Options/Peripheral Equipment  
LV5/Wires  
Product List  
Precautions

# Direct Drive Motors

## TM-RG2M/TM-RU2M Series Specifications

Direct drive motor model		TM-RG2M	002C30	004E30	009G30
		TM-RU2M			
Compatible servo amplifier model		MR-J4- MR-J4W_-	Refer to "Combinations of Direct Drive Motor and Servo Amplifier" on p. 4-2 in this catalog.		
Motor outer diameter (frame dimensions)		[mm]	ø130	ø180	ø230
Power supply capacity *1 (Note 4)		[kVA]	0.25	0.5 <0.7>	0.9
Continuous running duty	Rated output (Note 4)	[W]	69	141 <188>	283
	Rated torque (Note 3, 4)	[N•m]	2.2	4.5 <6>	9
Maximum torque (Note 4)		[N•m]	8.8	13.5 <18>	27
Rated speed		[r/min]	300		
Maximum speed		[r/min]	600		
Permissible instantaneous speed		[r/min]	690		
Power rate at continuous rated torque (Note 4)		[kW/s]	6.1	3.4 <6.0>	5.5
Rated current (Note 4)		[A]	1.2	1.3 <1.7>	2.2
Maximum current (Note 4)		[A]	4.9	4.0 <5.3>	6.7
Regenerative braking frequency *2 (Note 4)	MR-J4-	[times/min]	1317	166 <167>	68
	MR-J4W_-	[times/min]	1317	166 <167>	68
Moment of inertia J		[× 10 <sup>-4</sup> kg•m <sup>2</sup> ]	7.88	60.2	147
Recommended load to motor inertia ratio (Note 1)			50 times or less	20 times or less	
Absolute accuracy (Note 6)		[s]	±15	±12.5	
Speed/position detector	Absolute/incremental *3		21-bit encoder 2097152 pulses/rev	22-bit encoder 4194304 pulses/rev	
Type			Permanent magnet synchronous motor		
Thermistor			Built-in		
Insulation class			155 (F)		
Structure			Totally enclosed, natural cooling (IP rating: IP40) (Note 2)		
Environment *4, *8	Ambient temperature		Operation: 0 °C to 40 °C (non-freezing), storage: -15 °C to 70 °C (non-freezing)		
	Ambient humidity		Operation: 10 %RH to 80 %RH (non-condensing), storage: 10 %RH to 90 %RH (non-condensing)		
	Ambience		Indoors (no direct sunlight); no corrosive gas, inflammable gas, oil mist or dust		
	Altitude		2000 m or less above sea level (Note 5)		
	Vibration resistance *5		X: 49 m/s <sup>2</sup> Y: 49 m/s <sup>2</sup>		
Vibration rank			V10 *7		
Rotor permissible load *6	Moment load	[N•m]	15	49	65
	Axial load	[N]	770	2300	3800
Mass		[kg]	2.7	5.5	8.3

Notes: 1. Contact your local sales office if the load to motor inertia ratio exceeds the value in the table.

2. Connectors and a gap along the rotor (output shaft) are excluded.

3. When unbalanced torque is generated, such as in a vertical lift machine, be sure to use the absolute position detection system, and keep the unbalanced torque under 70% of the servo motor rated torque.

4. The value in angle brackets is applicable when the rated and maximum torques are increased with a combination with a larger-capacity servo amplifier. Refer to "Combinations of Direct Drive Motor and Servo Amplifier" on p. 4-2 in this catalog for the combinations.

5. Refer to "TM-RFM TM-RG2M TM-RU2M Direct Drive Motor Instruction Manual" for the restrictions when using the direct drive motors at altitude exceeding 1000 m and up to 2000 m above sea level.

6. Absolute accuracy varies according to the mounting state of load and the surrounding environment.

Refer to "Annotations for Direct Drive Motor Specifications" on p. 4-8 in this catalog for the asterisks 1 to 8.

## TM-RG2M/TM-RU2M Series Torque Characteristics

**TM-RG2M002C30,  
TM-RU2M002C30** (Note 1, 2, 3)

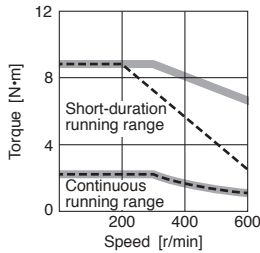

**TM-RG2M004E30,  
TM-RU2M004E30** (Note 1, 2, 3)

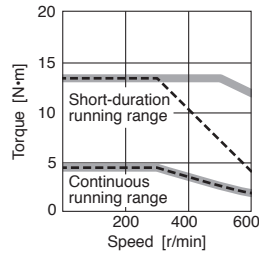

**TM-RG2M004E30,  
TM-RU2M004E30** (Note 1, 2, 3, 4)  
(when torque is increased)

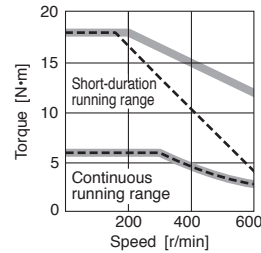

**TM-RG2M009G30,  
TM-RU2M009G30** (Note 1, 2, 3)

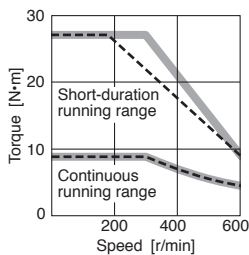

- Notes: 1. — : For 3-phase 200 V AC or 1-phase 230 V AC.  
 2. - - - : For 1-phase 200 V AC or 1-phase 100 V AC.  
 3. Torque drops when the power supply voltage is below the specified value.  
 4. This value is applicable when the rated and maximum torques are increased with a combination with a larger-capacity servo amplifier. Refer to "Combinations of Direct Drive Motor and Servo Amplifier" on p. 4-2 in this catalog for the combinations.

## Mounting of TM-RG2M/TM-RU2M Series

### ● Flange type (with pilot)

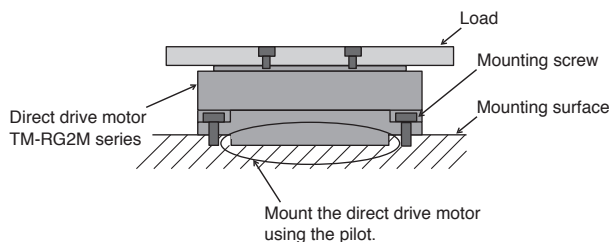

### ● Table type (with positioning pin holes)

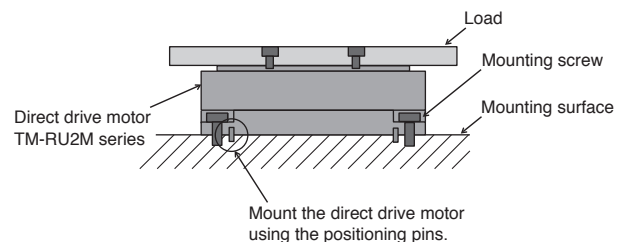

### Precautions when mounting the direct drive motor

- Fix the direct drive motor securely on a high-rigid mounting surface because a machine resonance may occur if the rigidity of the mounting surface is low.
- Fix the mounting screws of the direct drive motor and a rotating table securely to ensure enough rigidity.
- To ensure heat dissipation and accuracy, mount the direct drive motor on a high-rigid mounting surface which has enough heat dissipation area without gaps between the bottom of the direct drive motor and the mounting surface.
- The flange type has a higher mounting accuracy than the table type. When a high-mounting accuracy is required, select the flange type. Refer to "Direct Drive Motor Machine Accuracy" on p. 4-8 in this catalog for the machine accuracy of each direct drive motor, and refer to the dimensions in this catalog for the dimensional tolerance.

# Direct Drive Motors

## TM-RFM Series Specifications

Direct drive motor model		TM-RFM	002C20	004C20	006C20	006E20	012E20	018E20
Compatible servo amplifier model		MR-J4- MR-J4W_-	Refer to "Combinations of Direct Drive Motor and Servo Amplifier" on p. 4-2 in this catalog.					
Motor outer diameter (frame dimensions)		[mm]	ø130			ø180		
Power supply capacity *1		[kVA]	0.25	0.38	0.53	0.46	0.81	1.3
Continuous running duty	Rated output	[W]	42	84	126	126	251	377
	Rated torque (Note 3)	[N·m]	2	4	6	6	12	18
Maximum torque		[N·m]	6	12	18	18	36	54
Rated speed		[r/min]	200					
Maximum speed		[r/min]	500					
Permissible instantaneous speed		[r/min]	575					
Power rate at continuous rated torque		[kW/s]	3.7	9.6	16.1	4.9	12.9	21.8
Rated current		[A]	1.3	2.2	3.2	3.0	3.8	6.0
Maximum current		[A]	3.9	6.6	9.6	9.0	12	18
Regenerative braking frequency *2	MR-J4-	[times/min]	No limit	5830	2950	464	572	421
	MR-J4W_-	[times/min]	No limit	5620	No limit	2370	1430	1050
Moment of inertia J		[ $\times 10^{-4}$ kg·m <sup>2</sup> ]	10.9	16.6	22.4	74.0	111	149
Recommended load to motor inertia ratio (Note 1)			50 times or less					
Absolute accuracy (Note 5)		[s]	±15			±12.5		
Speed/position detector			Absolute/incremental 20-bit encoder *3 (resolution: 1048576 pulses/rev)					
Type			Permanent magnet synchronous motor					
Thermistor			Built-in					
Insulation class			155 (F)					
Structure			Totally enclosed, natural cooling (IP rating: IP42) (Note 2)					
Environment *4, *8	Ambient temperature		Operation: 0 °C to 40 °C (non-freezing), storage: -15 °C to 70 °C (non-freezing)					
	Ambient humidity		Operation: 10 %RH to 80 %RH (non-condensing), storage: 10 %RH to 90 %RH (non-condensing)					
	Ambience		Indoors (no direct sunlight); no corrosive gas, inflammable gas, oil mist or dust					
	Altitude		2000 m or less above sea level (Note 4)					
	Vibration resistance *5		X: 49 m/s <sup>2</sup> Y: 49 m/s <sup>2</sup>					
Vibration rank			V10 *7					
Rotor permissible load *6	Moment load	[N·m]	22.5			70		
	Axial load	[N]	1100			3300		
Mass		[kg]	5.2	6.8	8.4	11	15	18

Notes: 1. Contact your local sales office if the load to motor inertia ratio exceeds the value in the table.

2. Connectors and a gap along the rotor (output shaft) are excluded.

3. When unbalanced torque is generated, such as in a vertical lift machine, be sure to use the absolute position detection system, and keep the unbalanced torque under 70% of the servo motor rated torque.

4. Refer to "TM-RFM TM-RG2M TM-RU2M Direct Drive Motor Instruction Manual" for the restrictions when using the direct drive motors at altitude exceeding 1000 m and up to 2000 m above sea level.

5. Absolute accuracy varies according to the mounting state of load and the surrounding environment.

Refer to "Annotations for Direct Drive Motor Specifications" on p. 4-8 in this catalog for the asterisks 1 to 8.

## TM-RFM Series Specifications

Direct drive motor model		TM-RFM	012G20	048G20	072G20	040J10	120J10	240J10
Compatible servo amplifier model		MR-J4- MR-J4W_-	Refer to "Combinations of Direct Drive Motor and Servo Amplifier" on p. 4-2 in this catalog.					
Motor outer diameter (frame dimensions)		[mm]	ø230			ø330		
Power supply capacity <sup>*1</sup>		[kVA]	0.71	2.7	3.8	1.2	3.4	6.6
Continuous running duty	Rated output	[W]	251	1005	1508	419	1257	2513
	Rated torque <sup>(Note 3)</sup>	[N·m]	12	48	72	40	120	240
Maximum torque		[N·m]	36	144	216	120	360	720
Rated speed		[r/min]	200			100		
Maximum speed		[r/min]	500			200		
Permissible instantaneous speed		[r/min]	575			230		
Power rate at continuous rated torque		[kW/s]	6.0	37.5	59.3	9.4	40.9	91.4
Rated current		[A]	3.6	11	16	4.3	11	19
Maximum current		[A]	11	33	48	13	33	57
Regenerative braking frequency <sup>*2</sup>	MR-J4-	[times/min]	202	373	251	125	281	171
	MR-J4W_-	[times/min]	507	-	-	313	-	-
Moment of inertia J		[× 10 <sup>-4</sup> kg·m <sup>2</sup> ]	238	615	875	1694	3519	6303
Recommended load to motor inertia ratio <sup>(Note 1)</sup>			50 times or less					
Absolute accuracy <sup>(Note 5)</sup>		[s]	±12.5			±10		
Speed/position detector			Absolute/incremental 20-bit encoder <sup>*3</sup> (resolution: 1048576 pulses/rev)					
Type			Permanent magnet synchronous motor					
Thermistor			Built-in					
Insulation class			155 (F)					
Structure			Totally enclosed, natural cooling (IP rating: IP42) <sup>(Note 2)</sup>					
Environment <sup>*4, *8</sup>	Ambient temperature		Operation: 0 °C to 40 °C (non-freezing), storage: -15 °C to 70 °C (non-freezing)					
	Ambient humidity		Operation: 10 %RH to 80 %RH (non-condensing), storage: 10 %RH to 90 %RH (non-condensing)					
	Ambience		Indoors (no direct sunlight); no corrosive gas, inflammable gas, oil mist or dust					
	Altitude		2000 m or less above sea level <sup>(Note 4)</sup>					
Vibration resistance <sup>*5</sup>			X: 49 m/s <sup>2</sup> Y: 49 m/s <sup>2</sup>			X: 24.5 m/s <sup>2</sup> Y: 24.5 m/s <sup>2</sup>		
Vibration rank			V10 <sup>*7</sup>					
Rotor permissible load <sup>*6</sup>	Moment load	[N·m]	93			350		
	Axial load	[N]	5500			16000		
Mass		[kg]	17	36	52	53	91	146

Notes: 1. Contact your local sales office if the load to motor inertia ratio exceeds the value in the table.

2. Connectors and a gap along the rotor (output shaft) are excluded.

3. When unbalanced torque is generated, such as in a vertical lift machine, be sure to use the absolute position detection system, and keep the unbalanced torque under 70% of the servo motor rated torque.

4. Refer to "TM-RFM TM-RG2M TM-RU2M Direct Drive Motor Instruction Manual" for the restrictions when using the direct drive motors at altitude exceeding 1000 m and up to 2000 m above sea level.

5. Absolute accuracy varies according to the mounting state of load and the surrounding environment.

Refer to "Annotations for Direct Drive Motor Specifications" on p. 4-8 in this catalog for the asterisks 1 to 8.

# Direct Drive Motors

## TM-RFM Series Torque Characteristics

**TM-RFM002C20** (Note 1, 2, 4)

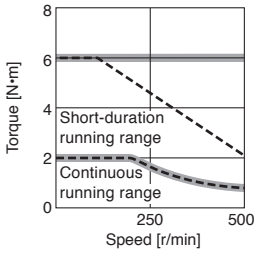

**TM-RFM004C20** (Note 1, 2, 4)

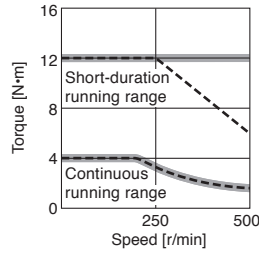

**TM-RFM006C20** (Note 1, 3, 4)

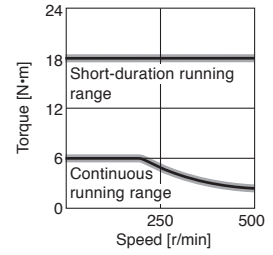

**TM-RFM006E20** (Note 1, 3, 4)

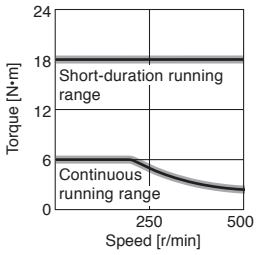

**TM-RFM012E20** (Note 1, 3, 4)

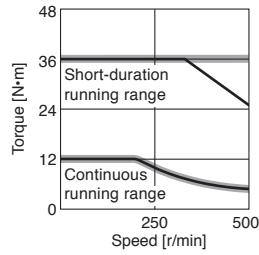

**TM-RFM018E20** (Note 1, 3, 4)

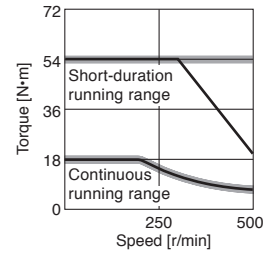

**TM-RFM012G20** (Note 1, 3, 4)

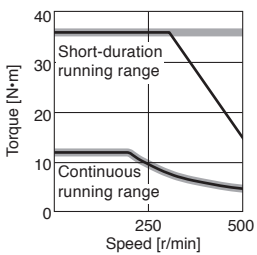

**TM-RFM048G20** (Note 1, 4)

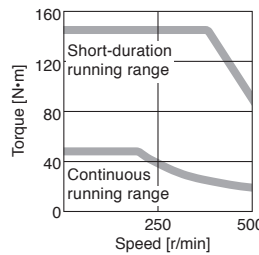

**TM-RFM072G20** (Note 1, 4)

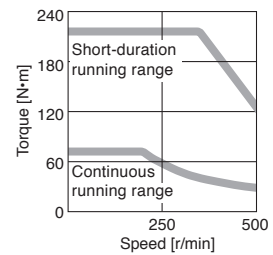

**TM-RFM040J10** (Note 1, 3, 4)

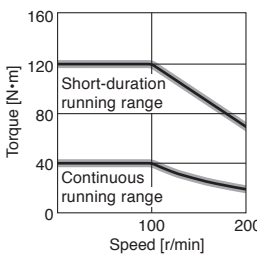

**TM-RFM120J10** (Note 1, 4)

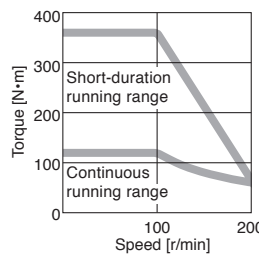

**TM-RFM240J10** (Note 1, 4)

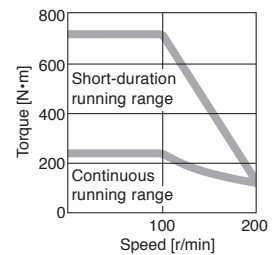

Notes: 1. — : For 3-phase 200 V AC or 1-phase 230 V AC.

The following direct drive motors are compatible with 1-phase 230 V AC:

TM-RFM002C20, TM-RFM004C20, TM-RFM006C20, TM-RFM006E20, TM-RFM012E20, TM-RFM018E20, TM-RFM012G20, TM-RFM040J10

2. - - - : For 1-phase 200 V AC or 1-phase 100 V AC.

3. — : For 1-phase 200 V AC.

4. Torque drops when the power supply voltage is below the specified value.



### Direct Drive Motor Machine Accuracy

The machine accuracy related to the direct drive motor rotor (output shaft) and mounting is indicated below:

Item	Measuring position	Accuracy [mm]
Runout of flange surface about rotor (output shaft)	a	0.05
Runout of fitting outer diameter of flange surface	b	0.07
Runout of rotor (output shaft)	c	0.04
Runout of rotor (output shaft) end	d	0.02

● TM-RG2M series

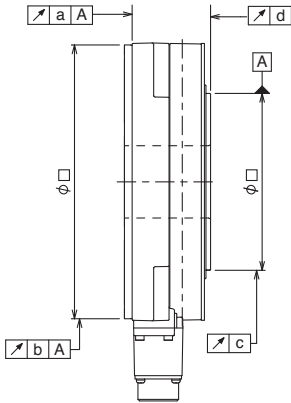

● TM-RU2M series

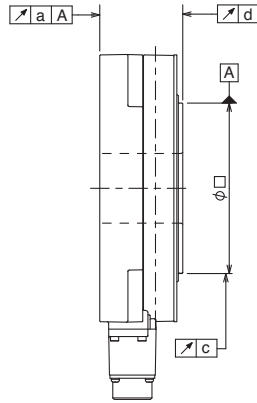

● TM-RFM series

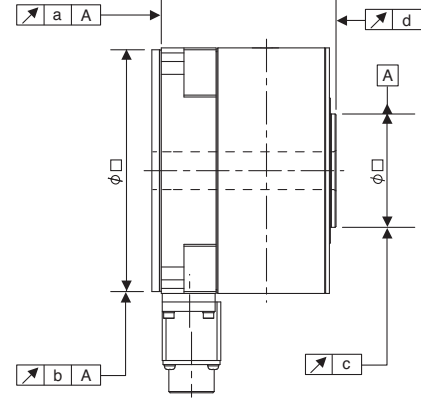

### Annotations for Direct Drive Motor Specifications

- \* 1. The power supply capacity varies depending on the power supply impedance. The listed values are the power supply capacity for one servo motor. For the multi-axis servo amplifiers, calculate the power supply capacity with the equation below:  
Power supply capacity [kVA] = Sum of power supply capacity [kVA] of the connected servo motors
- \* 2. The regenerative braking frequency shows the permissible frequency when the direct drive motor, without a load and a regenerative option, decelerates from the rated speed to a stop. When a load is connected, the value will be the table value/(m + 1), where m = Moment of inertia of load/Moment of inertia of direct drive motor. When the operating speed exceeds the rated speed, the regenerative braking frequency is inversely proportional to the square of (operating speed/rated speed). Take measures to keep the regenerative power [W] during operation below the permissible regenerative power [W]. Use caution, especially when the operating speed changes frequently or when the regeneration is constant (as with vertical feeds). Select the most suitable regenerative option for your system with our drive system sizing software Motorizer. Refer to "Regenerative Option" in this catalog for the permissible regenerative power [W] when a regenerative option is used.
- \* 3. Be sure to connect the following options for absolute position detection system.
  - MR-J4-GF: battery (MR-BAT6V1SET-A) and absolute position storage unit (MR-BTAS01)
  - MR-J4-B/MR-J4-A: battery (MR-BAT6V1SET) and absolute position storage unit (MR-BTAS01)
  - MR-J4W : battery case (MR-BT6VCASE), battery (MR-BAT6V1) × 5 pcs, and absolute position storage unit (MR-BTAS01)
 Refer to relevant Servo Amplifier Instruction Manual for details.
- \* 4. Do not use the servo motors in the environment where the servo motors are exposed to oil mist, oil and/or water.
- \* 5. The vibration direction is shown in the diagram below. The numerical value indicates the maximum value of the component. Fretting tends to occur on the bearing when the direct drive motor stops. Thus, maintain vibration level at approximately one-half of the allowable value.

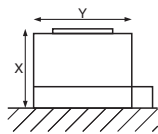

- \* 6. The following is calculation examples of axial and moment loads to the rotor (output shaft) of the direct drive motor. The axial and moment loads must be maintained equal to or below the permissible value.

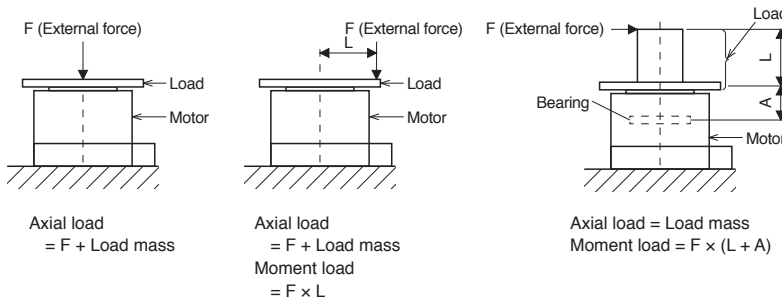

Motor outer diameter [mm] (Frame dimensions)	Dimension A [mm]	
	TM-RG2M series	TM-RFM series
ø130	20.6	19.1
ø180	20.7	20.2
ø230	18.0	24.4
ø330	-	32.5

- \* 7. V10 indicates that the amplitude of the direct drive motor itself is 10 μm or less. The following shows mounting orientation and measuring position of the direct drive motor during the measurement:

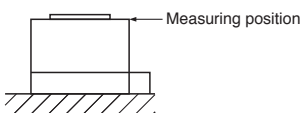

- \* 8. Do not place any object (such as a magnet) which generates a magnetic force near the direct drive motor. If it is unavoidable, take a measure such as mounting a shielding plate and so on to cut off the magnetic force.

Servo Amplifiers  
Rotary Servo Motors  
Linear Servo Motors  
Direct Drive Motors  
Options/Peripheral Equipment  
LV5/Wires  
Product List  
Precautions

# Direct Drive Motors

## TM-RG2M Series Dimensions (Note 1, 2)

### ● TM-RG2M002C30

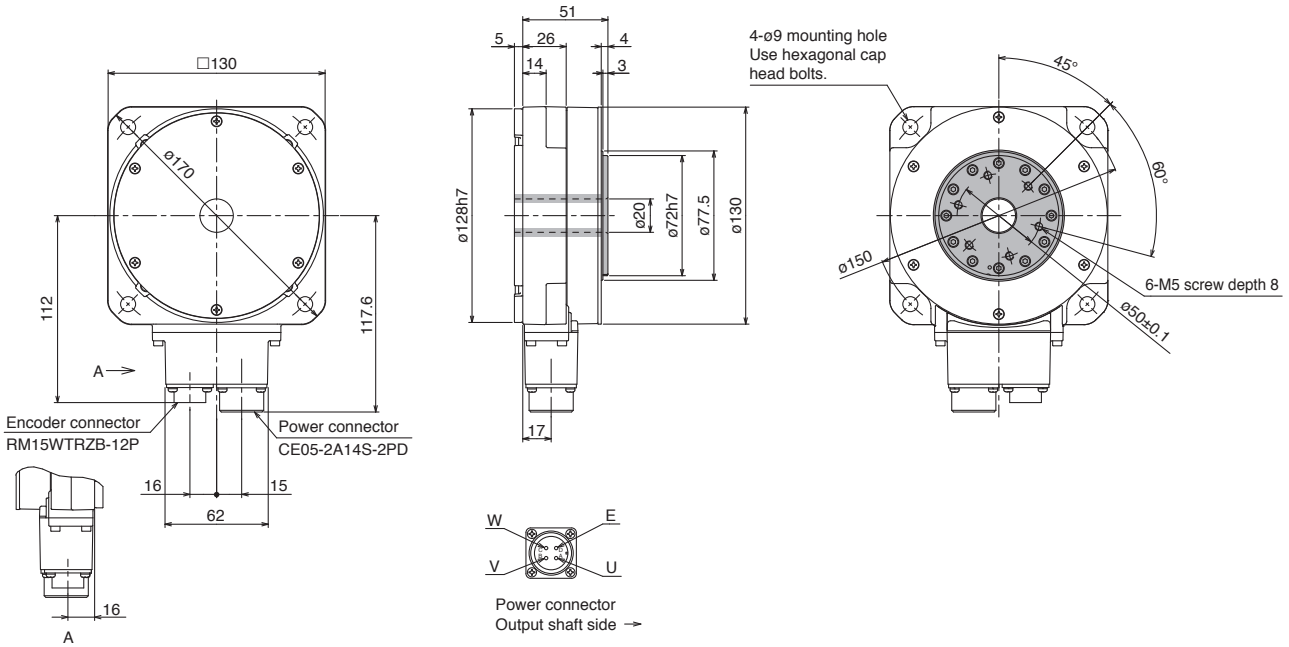

[Unit: mm]

### ● TM-RG2M004E30

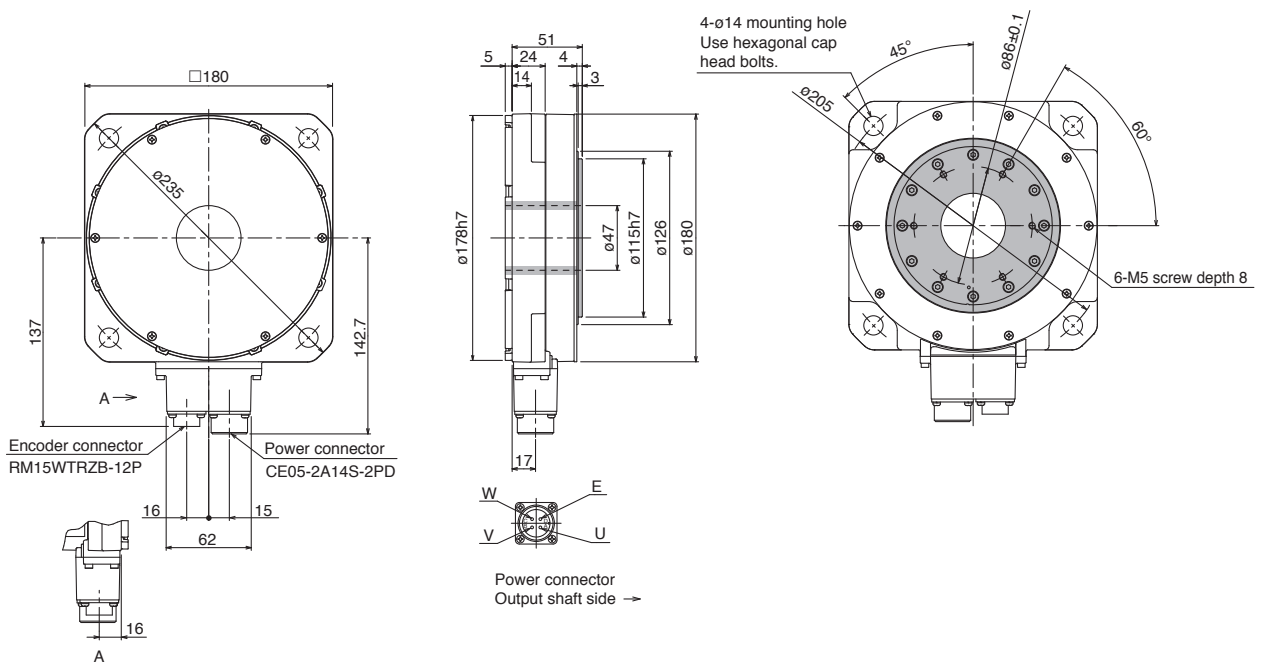

[Unit: mm]

Notes: 1. For dimensions without tolerance, general tolerance applies.  
2. ■ indicates rotor.

**TM-RG2M Series Dimensions** (Note 1, 2)

● **TM-RG2M009G30**

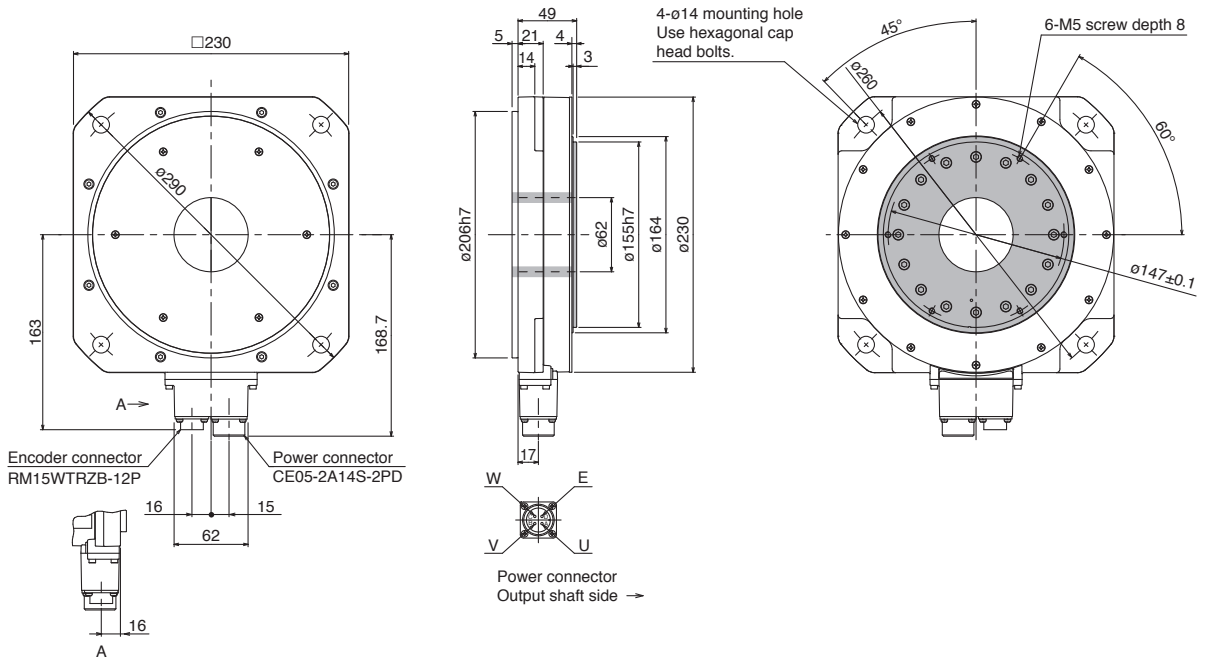

[Unit: mm]

Notes: 1. For dimensions without tolerance, general tolerance applies.  
 2. ■ indicates rotor.

Servo Amplifiers

Rotary Servo Motors

Linear Servo Motors

Direct Drive Motors

Options/Peripheral Equipment

LVS/Wires

Product List

Precautions

# Direct Drive Motors

## TM-RU2M Series Dimensions (Note 1, 2)

### ● TM-RU2M002C30

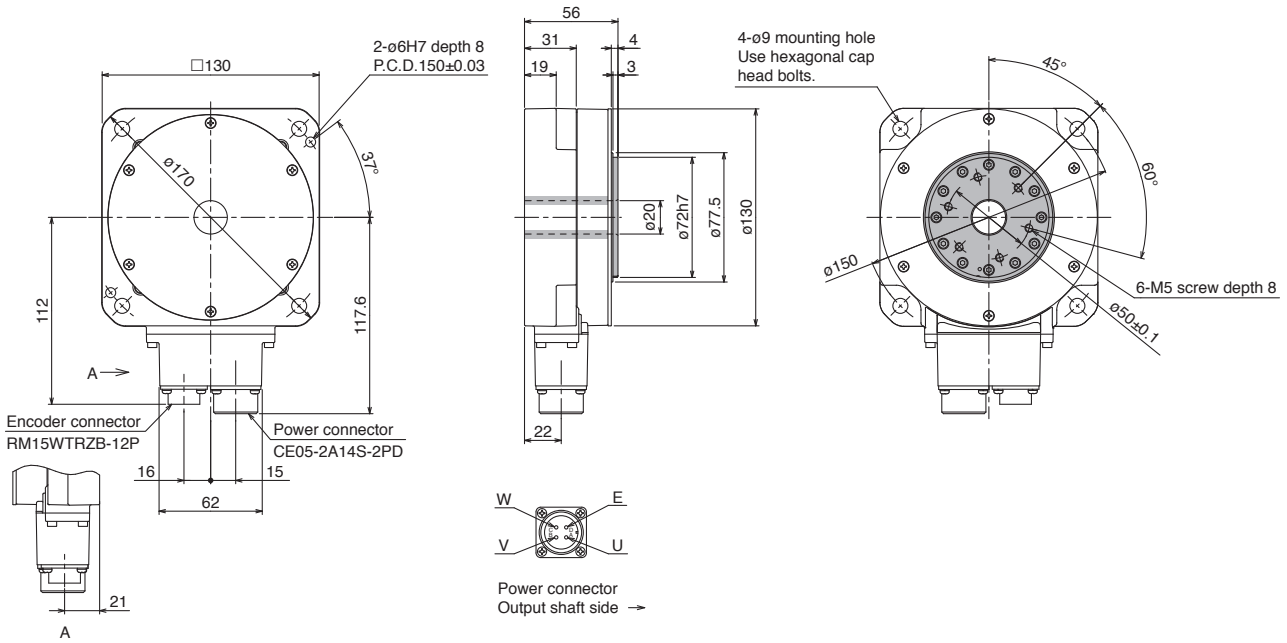

[Unit: mm]

### ● TM-RU2M004E30

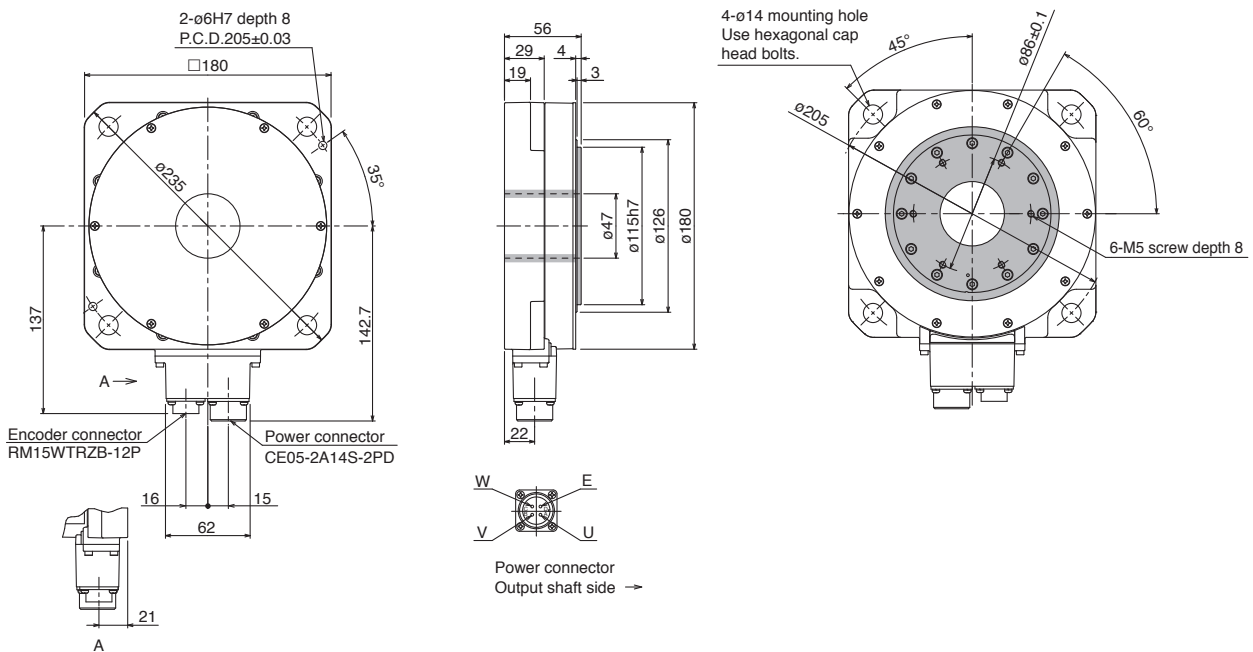

[Unit: mm]

Notes: 1. For dimensions without tolerance, general tolerance applies.  
2. ■ indicates rotor.

TM-RU2M Series Dimensions (Note 1, 2)

● TM-RU2M009G30

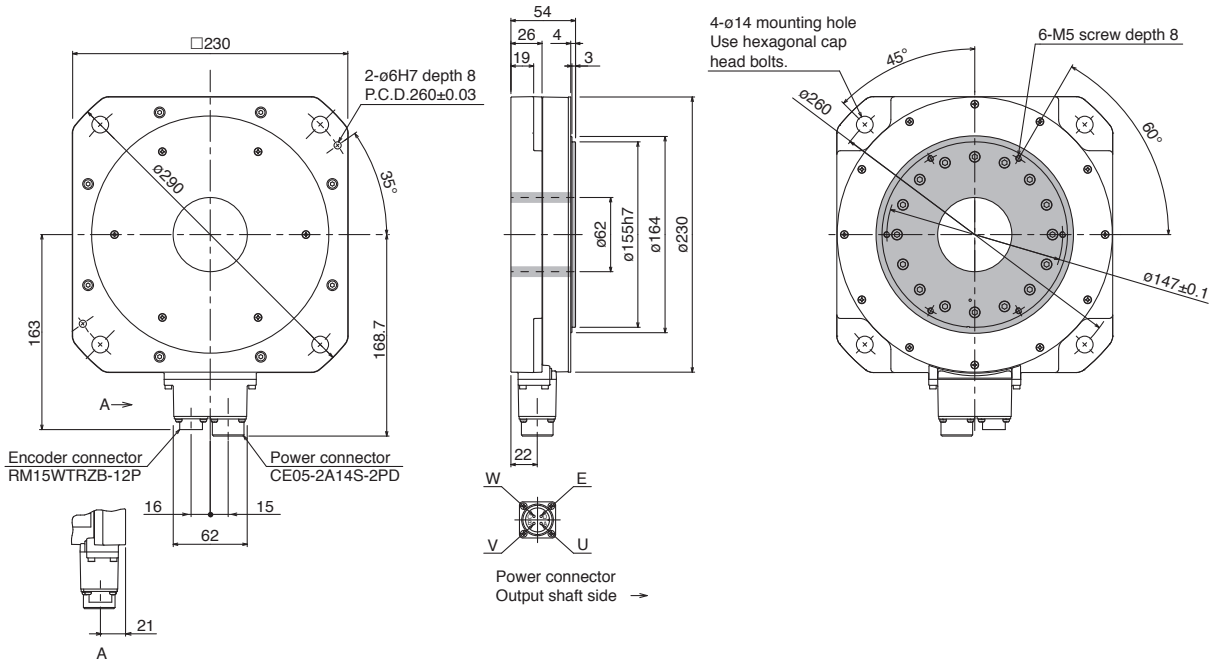

[Unit: mm]

Notes: 1. For dimensions without tolerance, general tolerance applies.  
 2. ■ indicates rotor.

Servo Amplifiers

Rotary Servo Motors

Linear Servo Motors

Direct Drive Motors

Options/Peripheral Equipment

LVS/Wires

Product List

Precautions

# Direct Drive Motors

## TM-RFM Series Dimensions (Note 1, 2)

### ● TM-RFM002C20, TM-RFM004C20, TM-RFM006C20

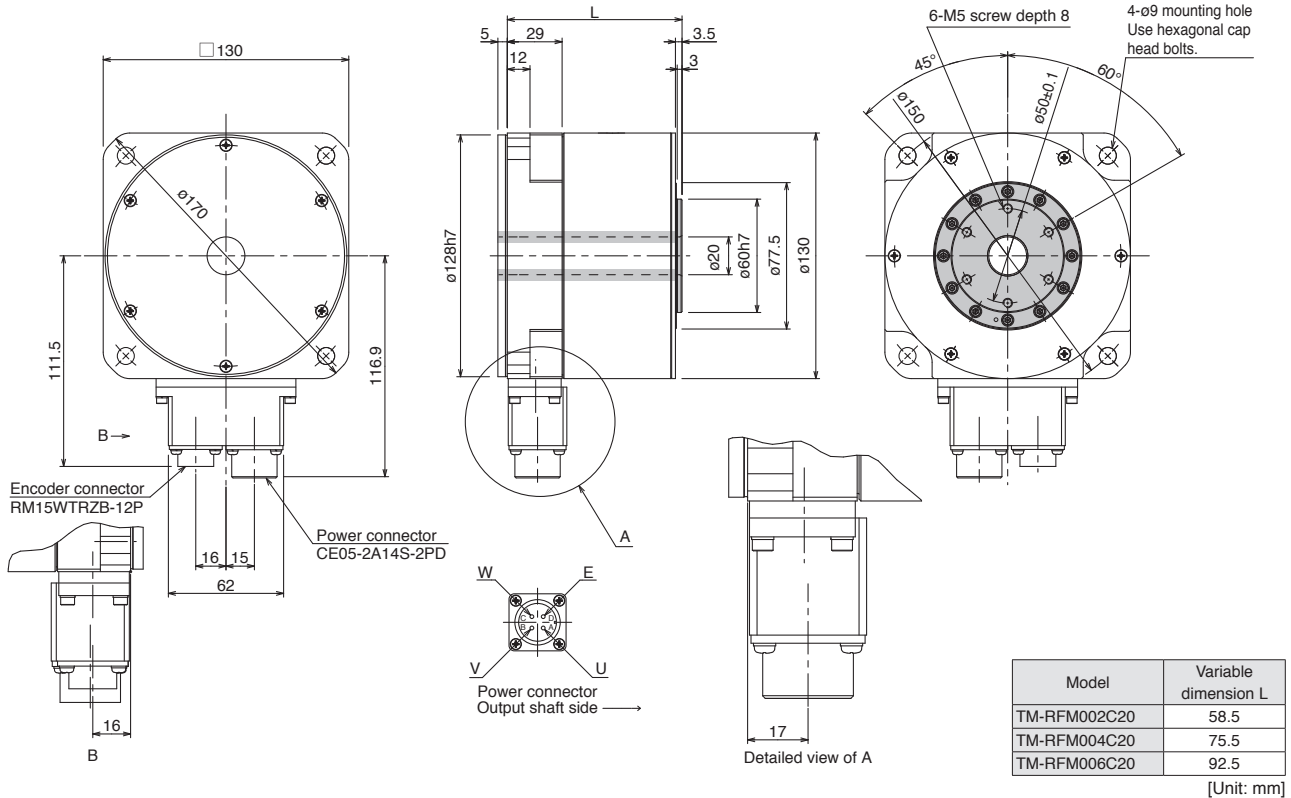

### ● TM-RFM006E20, TM-RFM012E20, TM-RFM018E20

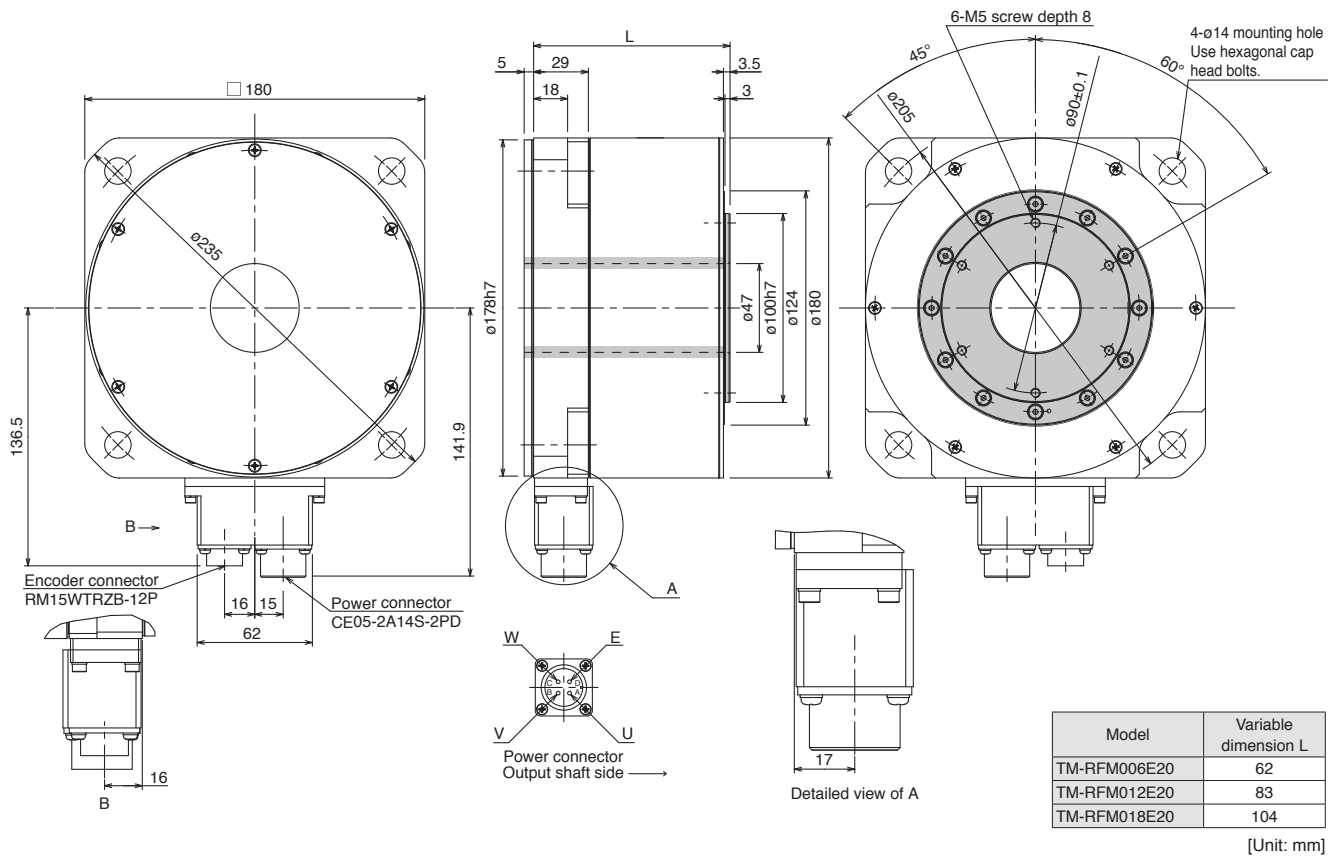

Notes: 1. For dimensions without tolerance, general tolerance applies. The actual dimensions may be 1 mm to 3 mm larger than the dimensions indicated. Make allowances for the tolerance when designing a machine.  
 2. ■ indicates rotor.

**TM-RFM Series Dimensions** (Note 1, 2)

● TM-RFM012G20, TM-RFM048G20, TM-RFM072G20

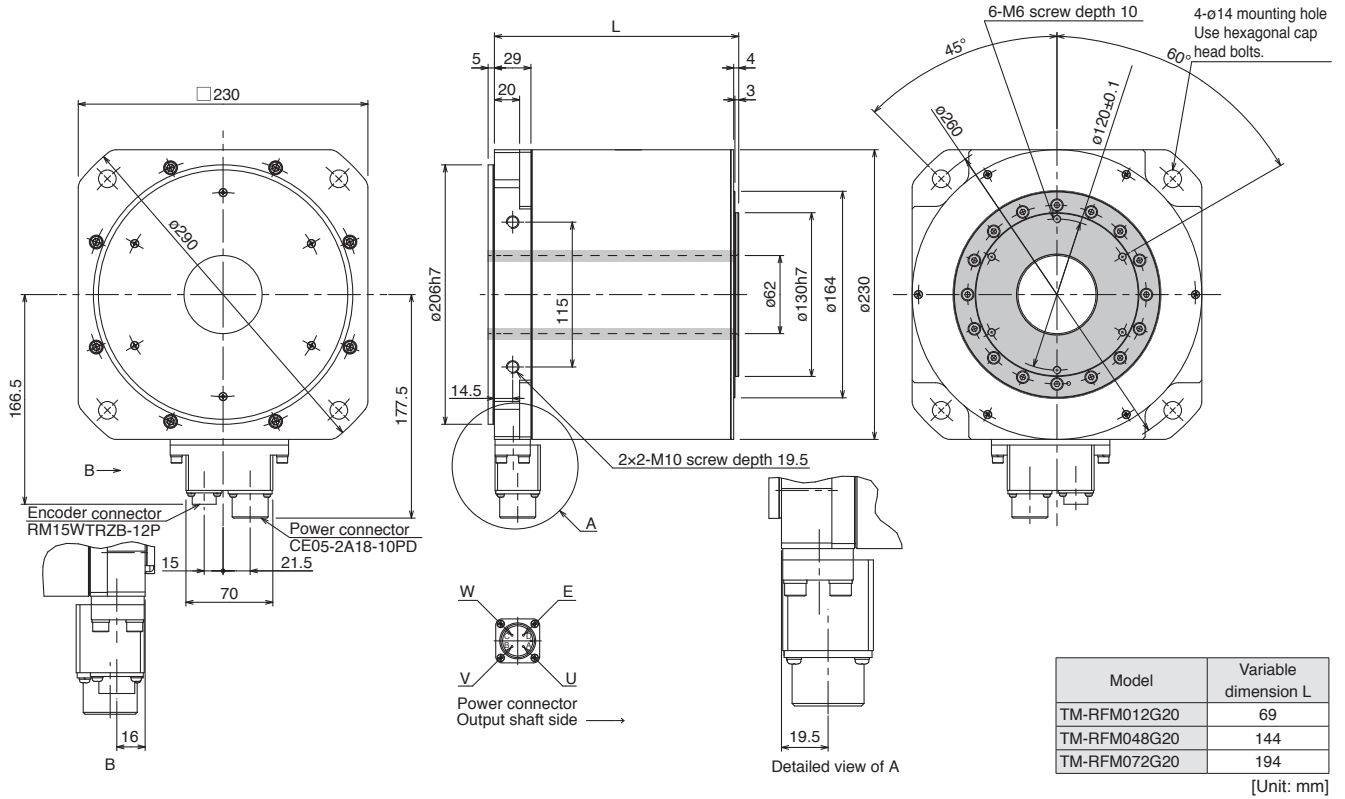

● TM-RFM040J10, TM-RFM120J10, TM-RFM240J10

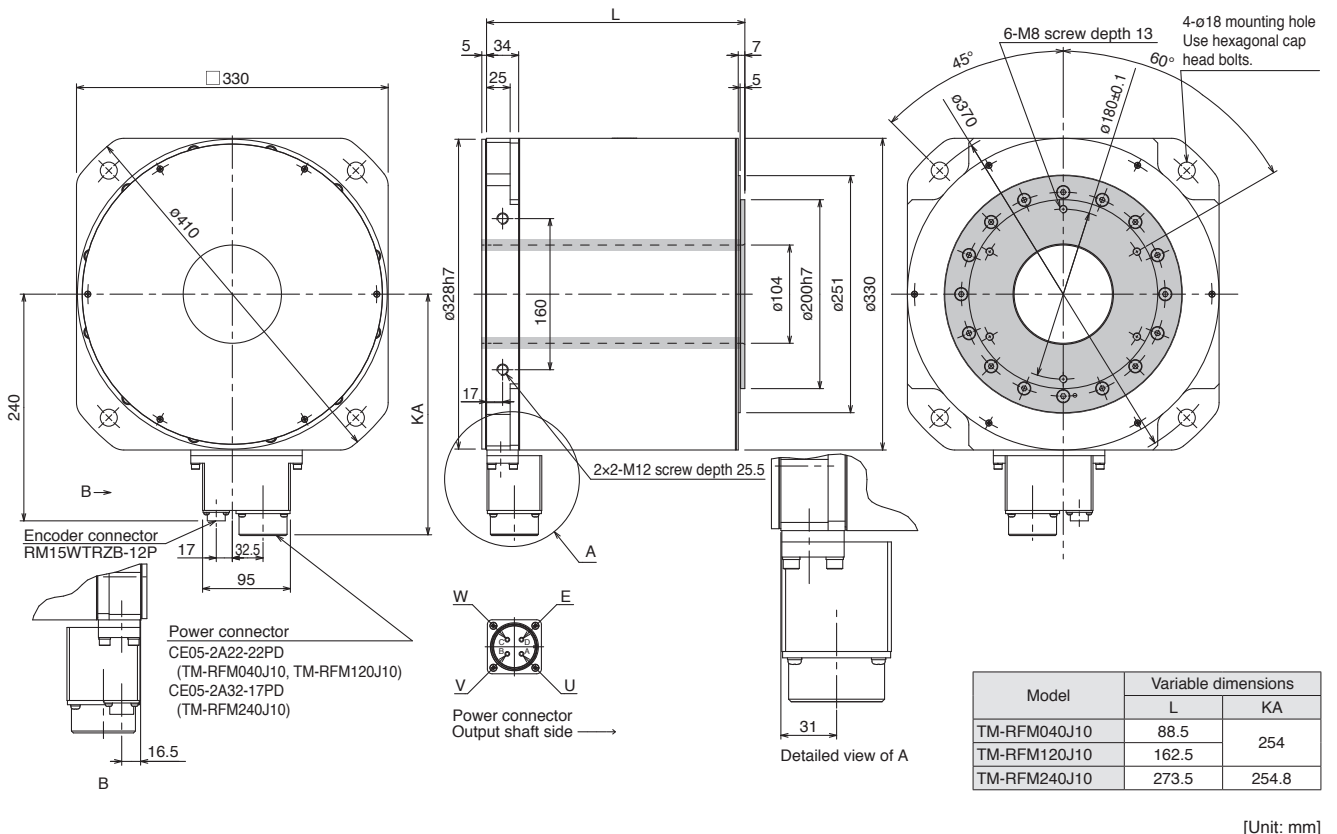

Notes: 1. For dimensions without tolerance, general tolerance applies. The actual dimensions may be 1 mm to 3 mm larger than the dimensions indicated. Make allowances for the tolerance when designing a machine.  
2. ■ indicates rotor.

# Direct Drive Motors

## Direct Drive Motor Sizing Example

### 1. Selection criteria

#### (1) Configurations

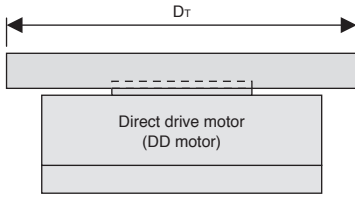

Table mass	W	= 19 kg
Rotation table diameter	$D_T$	= 300 mm
Rotation angle per cycle	$\theta$	= 270 deg
Positioning time	$t_o$	= Within 0.45 s
Acceleration/deceleration time	$t_p = t_{psa} = t_{psd}$	= 0.125 s
Operating cycle	$t_r$	= 2.0 s
Load torque	$T_L$	= 0 N·m

#### (2) Direct drive motor speed

$$N_0 = \frac{\theta}{360} \times \frac{60}{(t_o - t_p - t_s)}$$

$$= \frac{270}{360} \times \frac{60}{(0.45 - 0.125 - 0.1)} = 200 \text{ r/min}$$

$t_s$ : settling time. Here assumed 0.1 s.

#### (3) Operating pattern

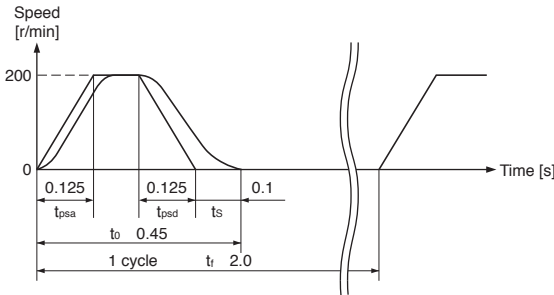

#### (4) Acceleration/deceleration torque

Torque required during acceleration

$$T_{Ma} = \frac{(J_L + J_M) \times N_0}{9.55 \times t_{psa}} = 38.3 \text{ N}\cdot\text{m}$$

$J_M$ : moment of inertia of DD motor

Torque required during deceleration

$$T_{Md} = - \frac{(J_L + J_M) \times N_0}{9.55 \times t_{psd}} = -38.3 \text{ N}\cdot\text{m}$$

Torque required during acceleration/deceleration must be equal to or lower than the max. torque of the DD motor.

#### (5) Continuous effective load torque

$$T_{rms} = \sqrt{\frac{T_{Ma}^2 \times t_{psa} + T_L^2 \times t_c + T_{Md}^2 \times t_{psd}}{t_r}} = 13.5 \text{ N}\cdot\text{m}$$

$$t_c = t_o - t_s - t_{psa} - t_{psd}$$

Continuous effective load torque must be equal to or lower than the rated torque of the DD motor.

### 2. Selecting direct drive motor

#### (1) Moment of inertia of load

$$J_L = \frac{1}{8} \times D_T^2 \times W$$

$$= \frac{1}{8} \times (300 \times 10^{-3})^2 \times 19 = 0.214 \text{ kg}\cdot\text{m}^2$$

#### (2) Torque required to accelerate/decelerate load

$$T_a = J_L \times \left( \frac{2\pi}{60} \times N_0 \right) \div t_p$$

$$= \frac{J_L \times N_0}{\frac{60}{2\pi} \times t_p}$$

$$= \frac{0.214 \times 200}{9.55 \times 0.125}$$

$$= 35.9 \text{ N}\cdot\text{m}$$

#### (3) Select a direct drive motor

Selection criteria

- Load torque during accel./decel. < Max. torque of DD motor
- Moment of inertia of load <  $J_R$  × Moment of inertia of DD motor
- $J_R$ : Recommended load to motor inertia ratio

Select the following direct drive motor to meet the criteria above.

TM-RFM018E20 (rated torque: 18 N·m, max. torque: 54 N·m, moment of inertia:  $149 \times 10^{-4} \text{ kg}\cdot\text{m}^2$ )

#### (6) Torque pattern

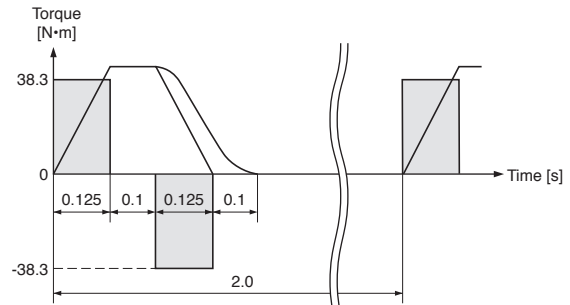

#### (7) Result

Select the following:

Direct drive motor: TM-RFM018E20

Servo amplifier: MR-J4-100B

[Drive System Sizing Software Motorizer]  
Motorizer does all the calculations for you. Contact your local sales office for more details.



# 5

## Options/Peripheral Equipment

	Servo amplifier								●: Applicable
	GF	GF-RJ	B	B-RJ	B-RJ100	WB	A	A-RJ	
Introducing FA Integrated Selection Tool	●	●	●	●	●	●	●	●	5-1
Basic Cable Configurations for Servo Motors	●	●	●	●	●	●	●	●	5-2
Configuration Example for Servo Motors	●	●	●	●	●	●	●	●	5-4
Details of Option Connectors for Servo Motors	●	●	●	●	●	●	●	●	5-19
Products on the Market for Servo Motors	●	●	●	●	●	●	●	●	5-23
Configuration Example for MR-J4-_GF_(-RJ)	●	●							5-31
Configuration Example for MR-J4-_B_(-RJ)/MR-J4-DU_B_(-RJ)			●	●					5-32
Configuration Example for MR-J4-DU_B4-RJ100					●				5-33
Configuration Example for MR-J4W2-_B_/MR-J4W3-_B						●			5-35
Configuration Example for MR-J4-_A_(-RJ)/MR-J4-DU_A_(-RJ)							●	●	5-36
Bus Bar			●	●	●				5-42
Configuration Example for MR-D30		●		●	●			●	5-44
Configuration Example for MR-J3-D05	●	●	●	●		●	●	●	5-44
Configuration Example for MR-D01								●	5-45
Details of Option Connectors for Servo Amplifiers/MR-D01/MR-D30/MR-J3-D05	●	●	●	●	●	●	●	●	5-46
Products on the Market for Servo Amplifiers	●	●	●	●	●	●	●	●	5-50
Functional Safety Unit		●		●	●			●	5-56
Safety Logic Unit	●	●	●	●		●	●	●	5-60
Extension IO Unit								●	5-62
Regenerative Option	●	●	●	●		●	●	●	5-64
Multifunction Regeneration Converter	●	●	●	●			●	●	5-70
Dynamic Brake	●	●	●	●	●		●	●	5-72
Battery	●	●	●	●	●	●	●	●	5-76
Battery for Junction Battery Cable and Junction Battery Cable	●	●	●	●	●		●	●	5-77
Battery Case and Battery	●	●	●	●		●	●	●	5-78
Absolute Position Storage Unit	●	●	●	●		●	●	●	5-79
Junction Terminal Block	●	●	●	●	●	●	●	●	5-80
Panel Through Attachment	●	●	●	●			●	●	5-82
Manual Pulse Generator								●	5-82
Parameter Unit					●		●	●	5-83
Radio Noise Filter/Line Noise Filter/Data Line Filter	●	●	●	●	●	●	●	●	5-84
Surge Killer	●	●	●	●	●	●	●	●	5-84
EMC Filter	●	●	●	●		●	●	●	5-85
Power Factor Improving Reactor	●	●	●	●	●	●	●	●	5-88
AC Reactor			●	●	●				5-97
Motorizer/MR Configurator2	●	●	●	●	●	●	●	●	5-98
Unit Conversion Table	●	●	●	●	●	●	●	●	5-100

**GF** MR-J4-GF **GF-RJ** MR-J4-GF-RJ **B** MR-J4-B/MR-J4-DU\_B **B-RJ** MR-J4-B-RJ/MR-J4-DU\_B-RJ **B-RJ100** MR-J4-DU\_B4-RJ100

**WB** MR-J4W2-B/MR-J4W3-B **A** MR-J4-A/MR-J4-DU\_A **A-RJ** MR-J4-A-RJ/MR-J4-DU\_A-RJ

\* Note that options/peripheral equipment necessary for servo amplifiers with special specifications are the same as those for standard servo amplifiers. Refer to the servo amplifiers with the same rated output.

\* Refer to p. 5-99 in this catalog for conversion of units.

\* In this section, a term of servo amplifier includes a combination of drive unit and power regeneration converter unit or resistance regeneration converter unit.

# Options/Peripheral Equipment

## Introducing FA Integrated Selection Tool

A new FA Integrated Selection Tool is now available for supporting you to select options such as encoder cables and power cables which are required to use with controllers, servo motors, servo amplifiers, and regenerative options of your choice.

When you select a controller, compatible servo motors are shown in a list. Just follow a guide of selecting servo motor series, rated output, rated speed and others, compatible servo amplifier and regenerative option will be listed along with necessary options, and then a system configuration will be complete.

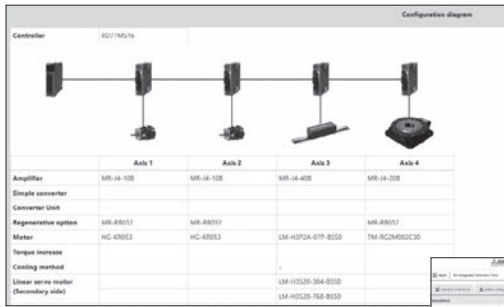

Configuration diagram window

In the configuration diagram, a controller, servo amplifiers, servo motors, and regenerative options are visually displayed. You will know the necessary components for each axis in your application at glance.

Moreover, making a purchase list is just a click away, and the purchase list can be exported to an Excel file. No more wasting time in selecting components and making a list.

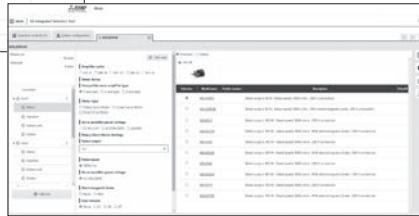

Servo motor selection window

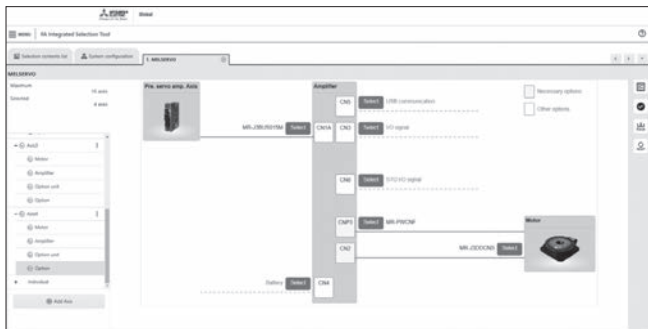

Option selection window

In the option selection window, servo motor power cable, encoder cable, electromagnetic cable and other options are selectable for each axis. Mandatory options are shown in yellow; thus, it is very clear which option must be purchased. Additionally, only connectable options are listed in each option selection window, preventing selection errors.

Notes: 1. This system is designed for reference only. Therefore, please use the results as reference, and be sure to check this catalog and relevant Instruction Manuals.

## Basic Cable Configurations for Servo Motors

Necessary option cables and connectors vary depending on the servo motor series.  
Refer to the following tables for necessary options.

### Selecting options for servo motor

Use the cables in the following tables.

For the cable descriptions, refer to the relevant letters in each list.

Capacity	Servo motor	Reference list		
		Encoder cable	Servo motor power cable	Electromagnetic brake cable (Note 1)
Ultra-small capacity	HG-AK	Column D in encoder cable list	Column D in servo motor power cable list	-
	HG-AK(B)	Column D in encoder cable list	Column E in servo motor power cable list	- (Note 3)
Small capacity	HG-KR	Column A in encoder cable list	Column A in servo motor power cable list	Column A in electromagnetic brake cable list
	HG-MR	Column A in encoder cable list	Column A in servo motor power cable list	Column A in electromagnetic brake cable list
Medium capacity	HG-SR	Column B in encoder cable list	Column B in servo motor power cable list	Column B in electromagnetic brake cable list
	HG-JR 3000 r/min series	Column B in encoder cable list	Column B in servo motor power cable list	Column B in electromagnetic brake cable list
	HG-RR	Column B in encoder cable list	Column C in servo motor power cable list	- (Note 2)
	HG-UR	Column B in encoder cable list	Column C in servo motor power cable list	Column C in electromagnetic brake cable list (Note 2)
Large capacity	HG-JR 1000 r/min series 6 kW to 12 kW	Column C in encoder cable list	Column B in servo motor power cable list	Column C in electromagnetic brake cable list
	HG-JR 1500 r/min series 7 kW to 15 kW			
	HG-JR 1000 r/min series 15 kW to 37 kW			
Ultra-large capacity	HG-JR 1500 r/min series 22 kW to 55 kW	Column C in encoder cable list	-	-
	HG-JR 2000 r/min series 110 kW to 220 kW	Column E in encoder cable list	-	-

Notes: 1. An electromagnetic brake cable is required only for servo motor with electromagnetic brake.

2. An electromagnetic brake connector set is not required for HG-UR series of 1.5 kW or smaller, and HG-RR series as the power connector has electromagnetic brake terminals.

3. An electromagnetic brake cable is not required for HG-AK series as the power connector of servo motor has electromagnetic brake terminals.

### Encoder cable list

	Cable length	IP rating (Note 1)	Cable lead out direction	Bending life (Note 2)	Model	Reference	Note
A	10 m or shorter (direct connection type)	IP65	In the direction of the load side	Long bending life	MR-J3ENCBL_M-A1-H	p. 5-12	Select one from this list.
				Standard	MR-J3ENCBL_M-A1-L		
			In the opposite direction of the load side	Long bending life	MR-J3ENCBL_M-A2-H	p. 5-12	
				Standard	MR-J3ENCBL_M-A2-L		
	Exceeding 10 m (junction type)	IP20	In the direction of the load side	Long bending life	Two types of cables are required: MR-J3JCBL03M-A1-L, MR-EKCBL_M-H	p. 5-12	
				Standard	Two types of cables are required: MR-J3JCBL03M-A1-L, MR-EKCBL_M-L		
			In the opposite direction of the load side	Long bending life	Two types of cables are required: MR-J3JCBL03M-A2-L, MR-EKCBL_M-H	p. 5-12	
				Standard	Two types of cables are required: MR-J3JCBL03M-A2-L, MR-EKCBL_M-L		
B	2 m to 50 m	IP65	In the direction of the load side	Long bending life	Two types of cables are required: MR-J3JSCBL03M-A1-L, MR-J3ENSCBL_M-H	pp. 5-12 and 5-13	
				Standard	Two types of cables are required: MR-J3JSCBL03M-A1-L, MR-J3ENSCBL_M-L		
			In the opposite direction of the load side	Long bending life	Two types of cables are required: MR-J3JSCBL03M-A2-L, MR-J3ENSCBL_M-H	pp. 5-12 and 5-13	
				Standard	Two types of cables are required: MR-J3JSCBL03M-A2-L, MR-J3ENSCBL_M-L		
C	2 m to 50 m	IP67	-	Long bending life	MR-J3ENSCBL_M-H	p. 5-13	
				Standard	MR-J3ENSCBL_M-L		
D	2 m to 50 m	IP67	-	Long bending life	MR-ENECBL_M-H-MTH	p. 5-14	-
D	1 m to 30 m	-	-	Long bending life	MR-J3W03ENCBL_M-A-H	p. 5-15	-
E	5 m to 50 m	IP67	-	Long bending life	MR-ENE4CBL_M-H-MTH	p. 5-15	-

Notes: 1. The IP rating indicated is for the connector's protection against ingress of dust and water when coupled to a servo amplifier/servo motor. If the IP rating of the servo amplifier/servo motor differs from that of these connectors, overall IP rating depends on the lowest of all.

2. Long bending life cables and standard cables are for moving parts and fixed parts respectively.

## Options/Peripheral Equipment

### Servo motor power cable list

	Cable length	IP rating (Note 1)	Cable lead out direction	Bending life (Note 2)	Model	Reference	Note
A	10 m or shorter (direct connection type)	IP65	In the direction of the load side	Long bending life	MR-PWS1CBL_M-A1-H	p. 5-16	Select one from this list.
				Standard	MR-PWS1CBL_M-A1-L		
	Exceeding 10 m (junction type)	IP55	In the opposite direction of the load side	Long bending life	MR-PWS1CBL_M-A2-H	p. 5-16	
				Standard	MR-PWS1CBL_M-A2-L		
Exceeding 10 m (junction type)	IP55	In the direction of the load side	Standard	Connect a user-fabricated cable to MR-PWS2CBL03M-A1-L (option cable).		p. 5-16	
				Connect a user-fabricated cable to MR-PWS2CBL03M-A2-L (option cable).		p. 5-16	

	IP rating (Note 1)	Compatible servo motor	Model	Reference	Note
B	IP67	HG-SR51, 81, 52(4), 102(4), 152(4)/ HG-JR53(4), 73(4), 103(4), 153(4), 203(4), 3534, 5034	Fabricate a cable that fits to MR-PWCNS4 (option connector set).	p. 5-16	Select one that is compatible with the servo motor.
		HG-SR121, 201, 301, 202(4), 352(4), 502(4)/HG-JR353, 503	Fabricate a cable that fits to MR-PWCNS5 (option connector set).	p. 5-16	
		HG-SR421, 702(4)/ HG-JR703(4), 903(4), 601(4), 801(4), 12K1(4), 701M(4), 11K1M(4), 15K1M(4)	Fabricate a cable that fits to MR-PWCNS3 (option connector set).	p. 5-16	
C	IP67	HG-RR103, 153, 203/ HG-UR72, 152	Fabricate a cable that fits to MR-PWCNS1 (option connector set).	p. 5-17	
		HG-RR353, 503/ HG-UR202, 352, 502	Fabricate a cable that fits to MR-PWCNS2 (option connector set).	p. 5-17	
D	-	HG-AK0136, 0236, 0336	MR-J4W03PWCBL_M-H	p. 5-17	-
E	-	HG-AK0136B, 0236B, 0336B	MR-J4W03PWBRCL_M-H	p. 5-17	-

### Electromagnetic brake cable list

	Cable length	IP rating (Note 1)	Cable lead out direction	Bending life (Note 2)	Model	Reference	Note
A	10 m or shorter (direct connection type)	IP65	In the direction of the load side	Long bending life	MR-BKS1CBL_M-A1-H	p. 5-18	Select one from this list.
				Standard	MR-BKS1CBL_M-A1-L		
	Exceeding 10 m (junction type)	IP55	In the opposite direction of the load side	Long bending life	MR-BKS1CBL_M-A2-H	p. 5-18	
				Standard	MR-BKS1CBL_M-A2-L		
Exceeding 10 m (junction type)	IP55	In the direction of the load side	Standard	Connect a user-fabricated cable to MR-BKS2CBL03M-A1-L (option cable).		p. 5-18	
				Connect a user-fabricated cable to MR-BKS2CBL03M-A2-L (option cable).		p. 5-18	

	IP rating (Note 1)	Compatible servo motor	Model	Reference	Note
B	IP67	HG-SR series HG-JR53(4)B, 73(4)B, 103(4)B, 153(4)B, 203(4)B, 353(4)B, 503(4)B, 703(4)B, 903(4)B	Fabricate a cable that fits to MR-BKCNS1 or MR-BKCNS2 (option connector set) (straight type).	p. 5-18	Select one that is compatible with the servo motor.
			Fabricate a cable that fits to MR-BKCNS1A or MR-BKCNS2A (option connector set) (angle type).	p. 5-18	
C	IP67	HG-JR601(4)B, 801(4)B, 12K1(4)B, 701M(4)B, 11K1M(4)B, 15K1M(4)B/ HG-UR202B, 352B, 502B	Fabricate a cable that fits to MR-BKCN (option connector set).	p. 5-18	

Notes: 1. The IP rating indicated is for the connector's protection against ingress of dust and water when coupled to a servo amplifier/servo motor. If the IP rating of the servo amplifier/servo motor differs from that of these connectors, overall IP rating depends on the lowest of all.  
2. Long bending life cables and standard cables are for moving parts and fixed parts respectively.

Configuration Example for Servo Motors

GF GF-RJ B B-RJ WB A A-RJ

For HG-KR/HG-MR rotary servo motor series: encoder cable length 10 m or shorter

● For leading the cables out in the direction of the load side (Note 4)

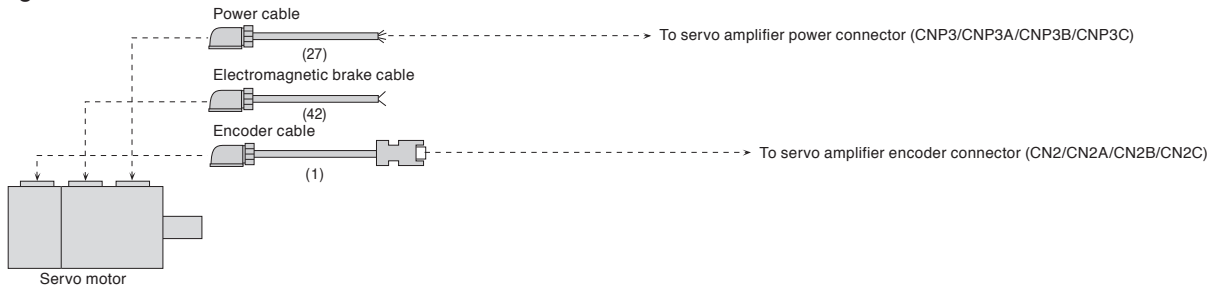

● For leading the cables out in the opposite direction of the load side (Note 4)

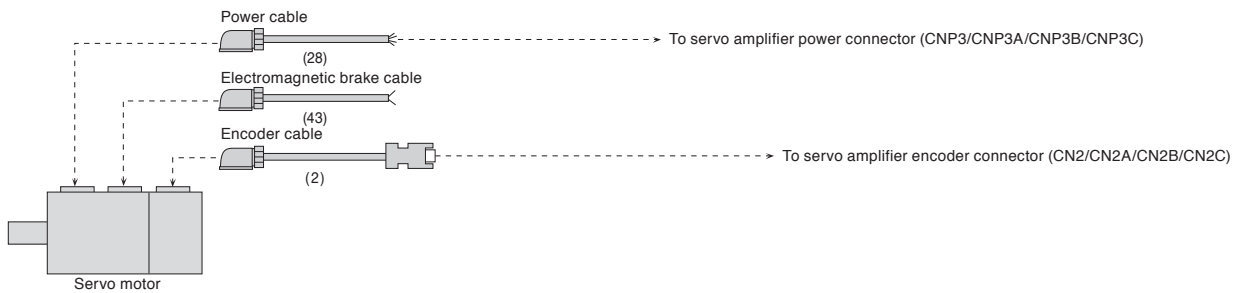

For HG-KR/HG-MR rotary servo motor series: encoder cable length over 10 m (Note 5)

● For leading the cables out in the direction of the load side (Note 4)

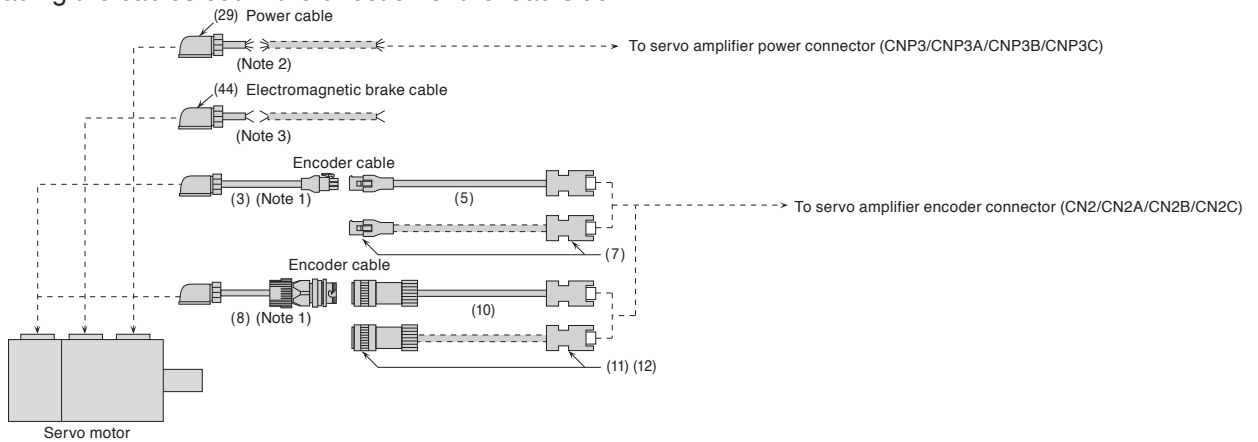

● For leading the cables out in the opposite direction of the load side (Note 4)

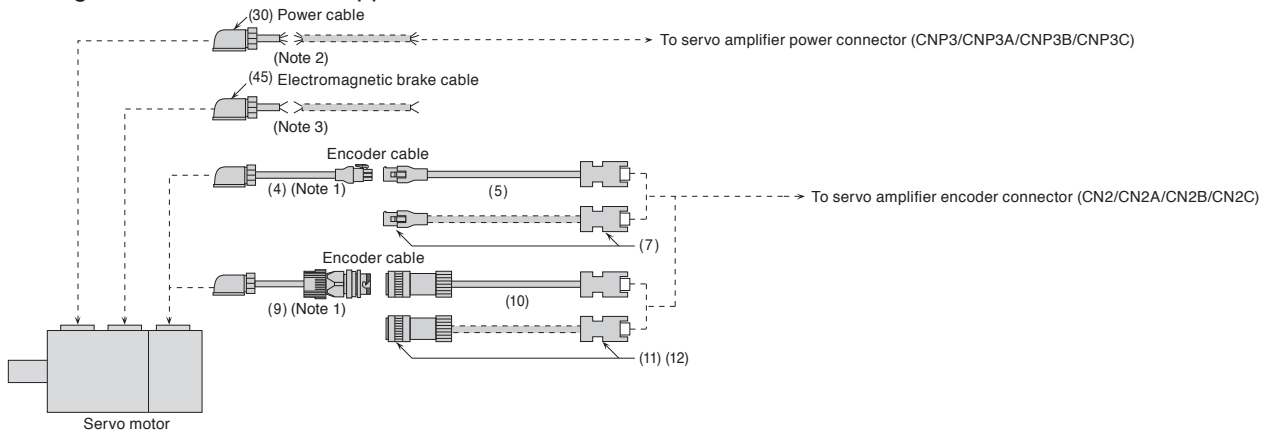

Notes: 1. This cable does not have a long bending life. Thus, be sure to fix the cable before using.  
 2. Relay a cable using MR-PWS2CBL03M-A1-L or MR-PWS2CBL03M-A2-L. This cable does not have a long bending life. Thus, be sure to fix the cable before using.  
 3. Relay a cable using MR-BKS2CBL03M-A1-L or MR-BKS2CBL03M-A2-L. This cable does not have a long bending life. Thus, be sure to fix the cable before using.  
 4. Cables for leading two different directions may be used for one servo motor.  
 5. Cables drawn with dashed lines need to be fabricated by user. Refer to relevant Servo Motor Instruction Manual for fabricating the cables.

## Configuration Example for Servo Motors (Note 1)

GF GF-RJ B B-RJ WB A A-RJ

For HG-SR rotary servo motor series

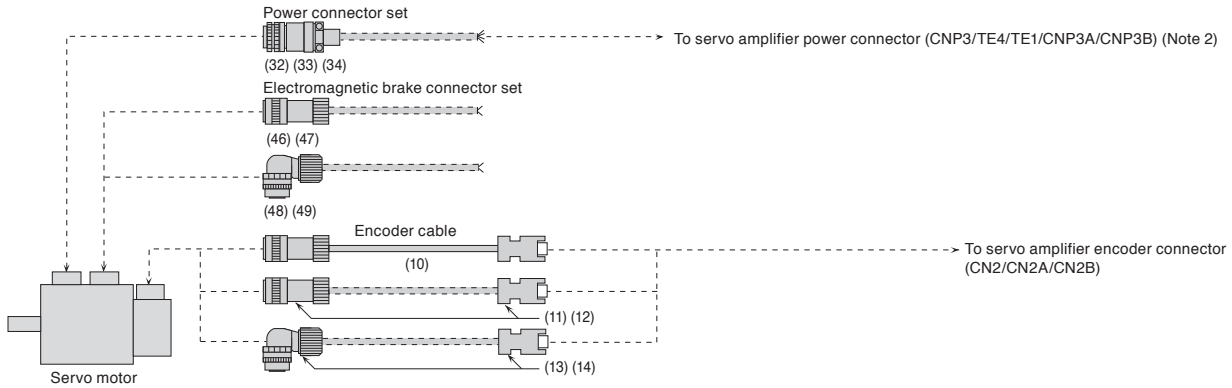

For HG-JR rotary servo motor 3000 r/min series

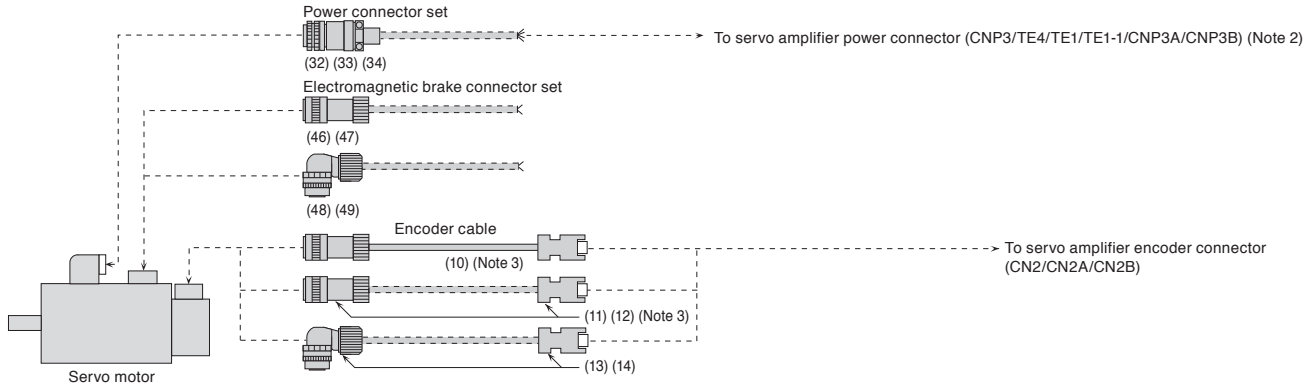

For HG-JR rotary servo motor 1000 r/min series (6 kW to 12 kW) and 1500 r/min series (7 kW to 15 kW)

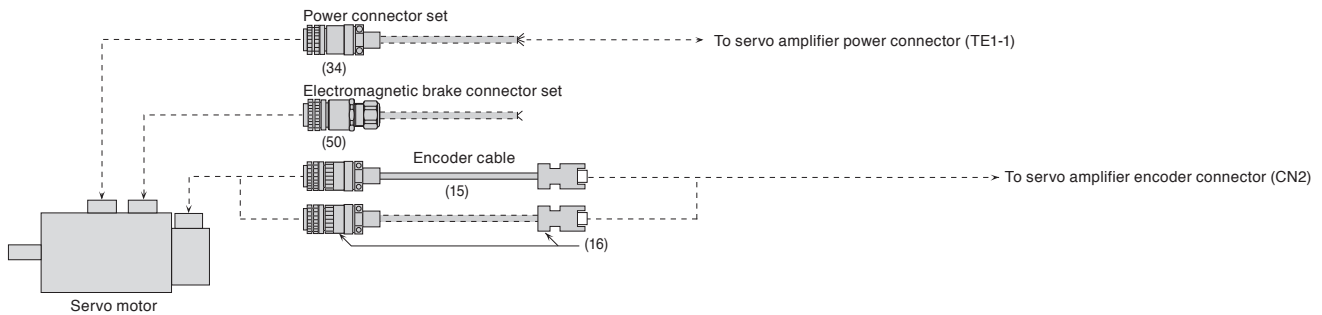

- Notes: 1. Cables drawn with dashed lines need to be fabricated by user. Refer to relevant Servo Motor Instruction Manual for fabricating the cables.  
 2. The connector for U, V, and W varies depending on the servo amplifier capacities. Refer to the dimensions of the relevant servo amplifier in this catalog for details.  
 3. For HG-JR703(B)/HG-JR7034(B)/HG-JR903(B)/HG-JR9034(B), straight types of (10), (11), and (12) cannot be used. Use an angle type of (13) or (14).

**Configuration Example for Servo Motors** (Note 5)

GF GF-RJ B B-RJ B-RJ100 WB A A-RJ

For HG-JR rotary servo motor 1000 r/min series (15 kW to 37 kW) and 1500 r/min series (22 kW to 55 kW)

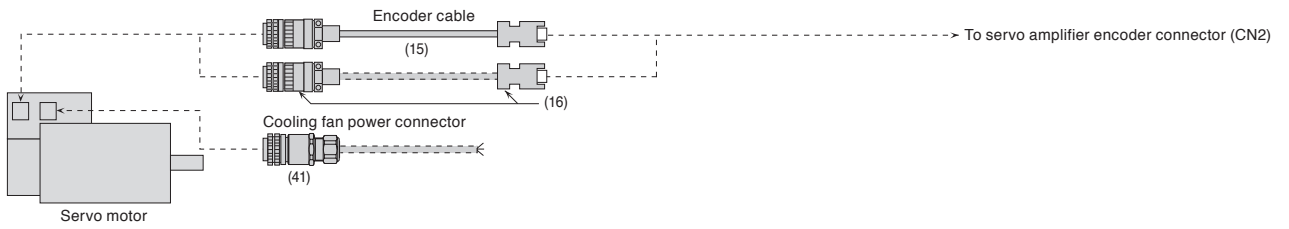

For HG-JR rotary servo motor 2000 r/min series

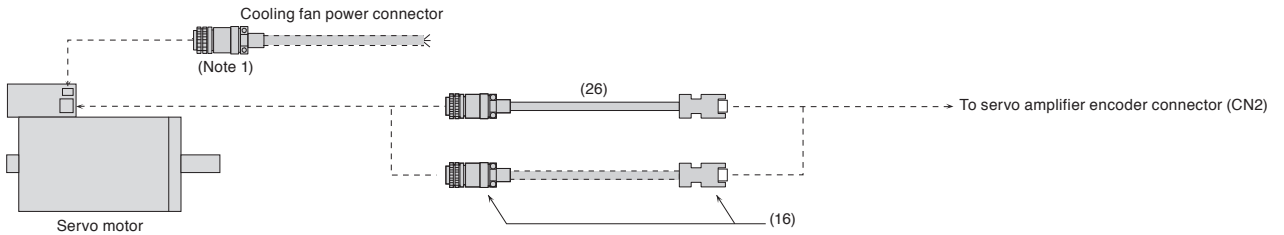

For HG-RR/HG-UR rotary servo motor series

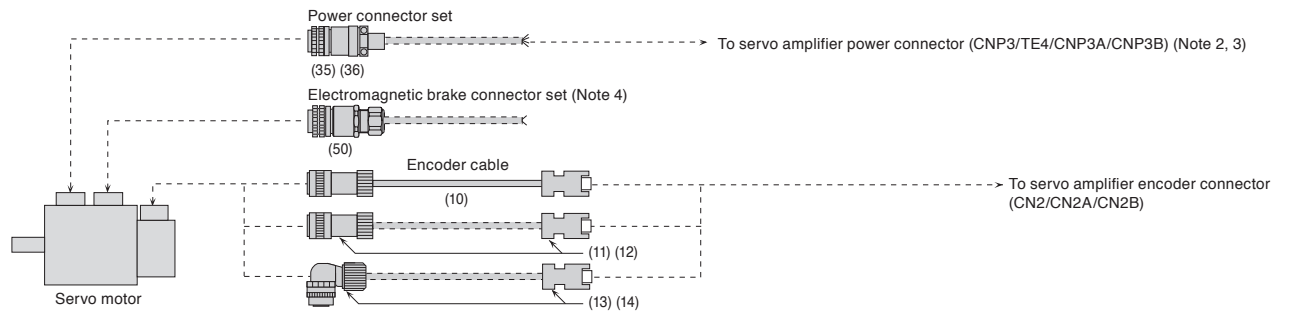

- Notes: 1. Refer to "Products on the Market for Servo Motors" on p. 5-30 in this catalog for these connectors.  
 2. The connector for U, V, and W varies depending on the servo amplifier capacities. Refer to the dimensions of the relevant servo amplifier in this catalog for details.  
 3. HG-RR series is compatible only with the 1-axis servo amplifier.  
 4. An electromagnetic brake connector set is not required for HG-UR series of 1.5 kW or smaller, and HG-RR series as the power connector has electromagnetic brake terminals.  
 5. Cables drawn with dashed lines need to be fabricated by user. Refer to relevant Servo Motor Instruction Manual for fabricating the cables.

Servo Amplifiers

Rotary Servo Motors

Linear Servo Motors

Direct Drive Motors

Options/Peripheral Equipment

LVS/Wires

Product List

Precautions

# Options/Peripheral Equipment

## Configuration Example for Servo Motors (Note 2)

For HG-AK rotary servo motor series

**WB** **A** **A-RJ**

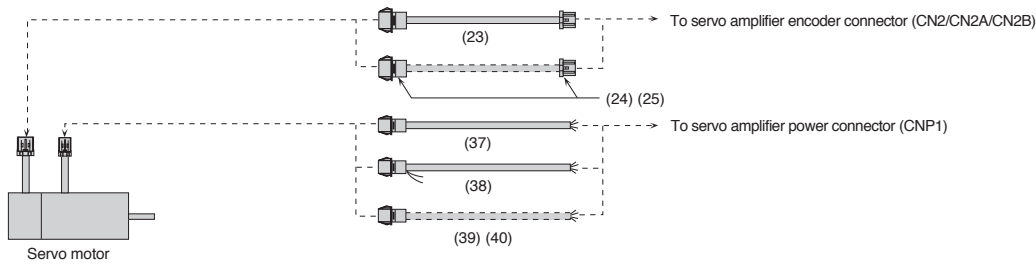

For fully closed loop control  
(MR-J4-GF/B/A, MR-J4-DU\_B/A, or MR-J4W2-B, and rotary servo motor) (Note 3)

**GF** **B** **WB** **A**

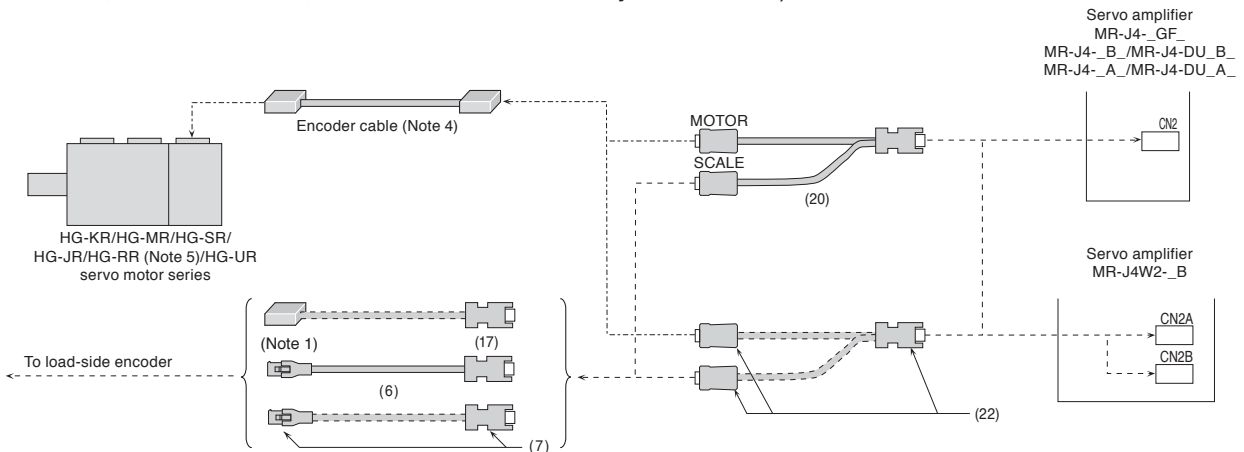

For fully closed loop control  
(MR-J4-GF-RJ/B-RJ/A-RJ or MR-J4-DU\_B-RJ/A-RJ, and rotary servo motor) (Note 3)

**GF-RJ** **B-RJ** **A-RJ**

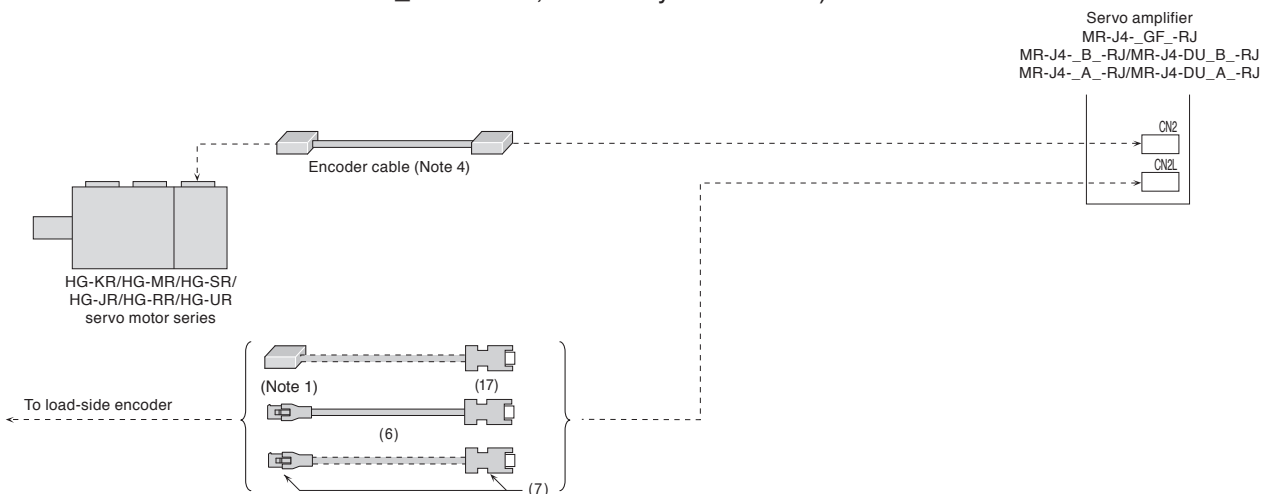

- Notes: 1. Contact the relevant linear encoder manufacturers for connectors to connect with the head cables.  
 2. Cables drawn with dashed lines need to be fabricated by user. Refer to relevant Servo Motor Instruction Manual for fabricating the cables.  
 3. Connections other than mentioned are the same as those for each rotary servo motor. Refer to cables and connectors for relevant servo motors in this catalog.  
 4. Necessary encoder cables vary depending on the servo motor series. Refer to cables and connectors for relevant servo motors in this catalog.  
 5. HG-RR series is compatible only with the 1-axis servo amplifier.



**Configuration Example for Servo Motors** (Note 3)

GF B WB A

For MR-J4-GF/B/A or MR-J4W\_-B, and LM-H3/LM-K2/LM-U2 linear servo motor series

● When using a junction cable for linear servo motor

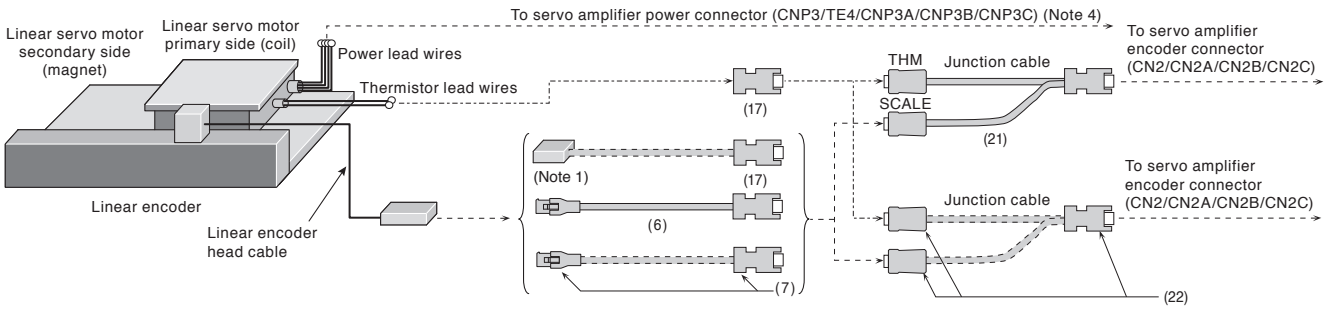

● When not using a junction cable for linear servo motor

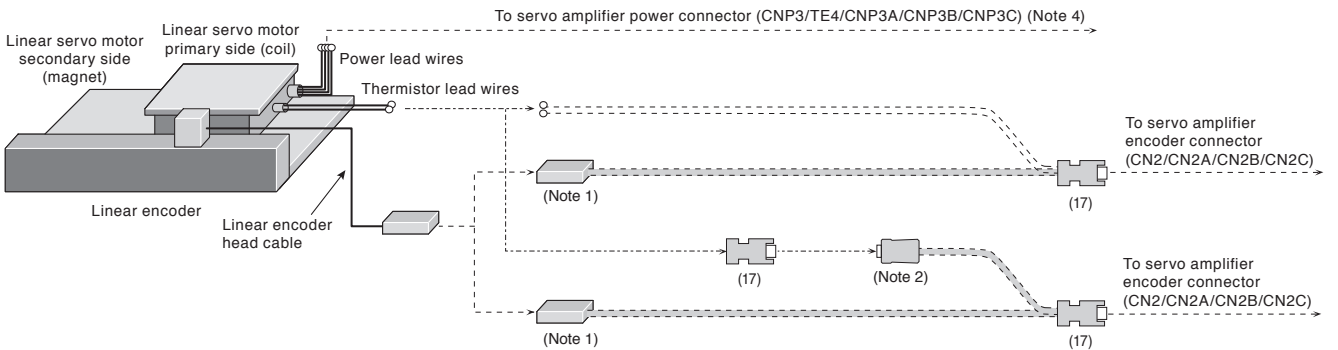

For MR-J4-GF/B/A and LM-F linear servo motor series

● When using a junction cable for linear servo motor

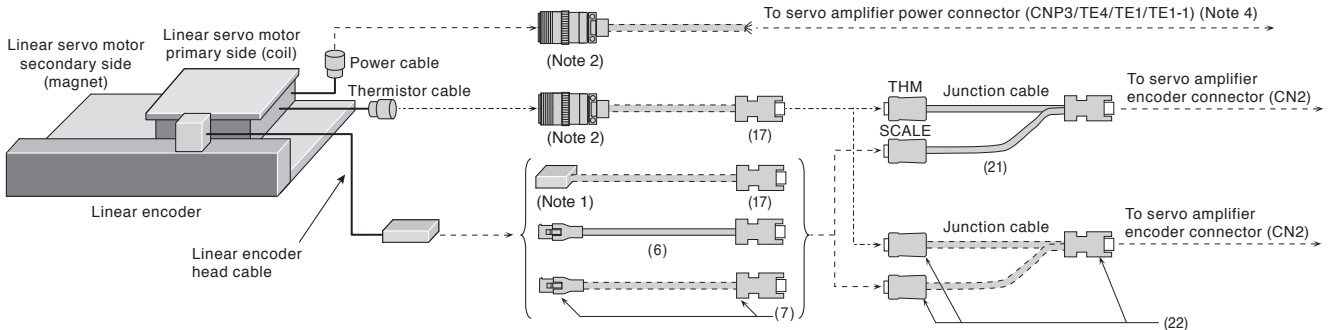

● When not using a junction cable for linear servo motor

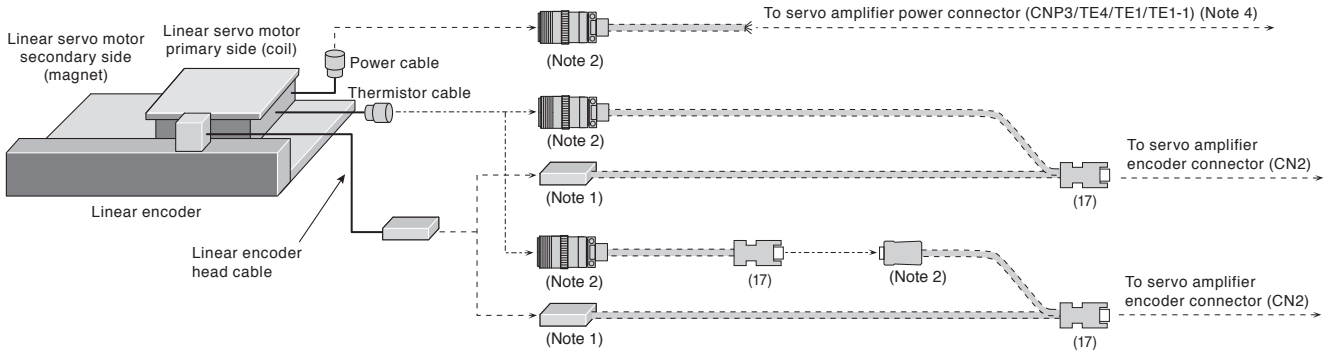

Notes: 1. Contact the relevant linear encoder manufacturers for connectors to connect with the head cables.  
 2. Refer to "Products on the Market for Servo Motors" in this catalog for these connectors.  
 3. Cables drawn with dashed lines need to be fabricated by user. Refer to relevant Servo Motor Instruction Manual for fabricating the cables.  
 4. The connector for U, V, and W varies depending on the servo amplifier capacities. Refer to the dimensions of the relevant servo amplifier in this catalog for details.

Servo Amplifiers  
 Rotary Servo Motors  
 Linear Servo Motors  
 Direct Drive Motors  
 Options/Peripheral Equipment  
 LVS/Wires  
 Product List  
 Precautions

## Configuration Example for Servo Motors (Note 3)

**GF-RJ** **B-RJ** **A-RJ**

For MR-J4-GF-RJ/B-RJ/A-RJ and LM-H3/LM-K2/LM-U2 linear servo motor series with a serial linear encoder

### ● When using a junction cable for linear servo motor

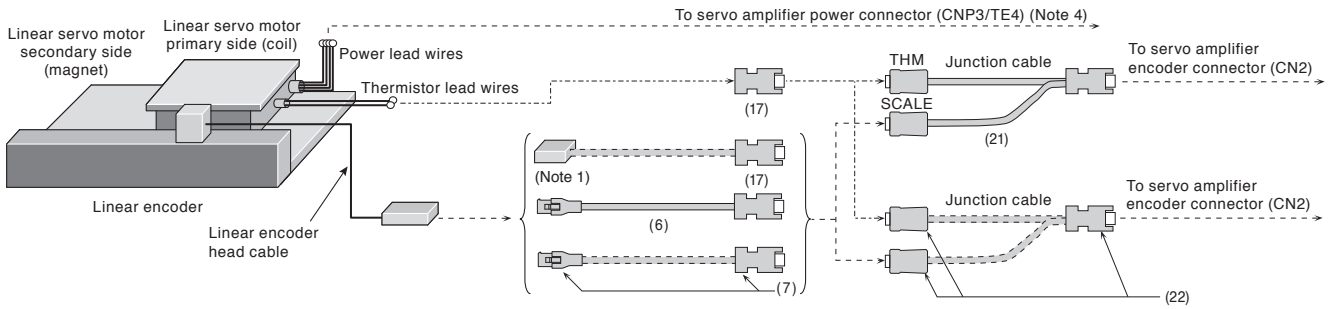

### ● When not using a junction cable for linear servo motor

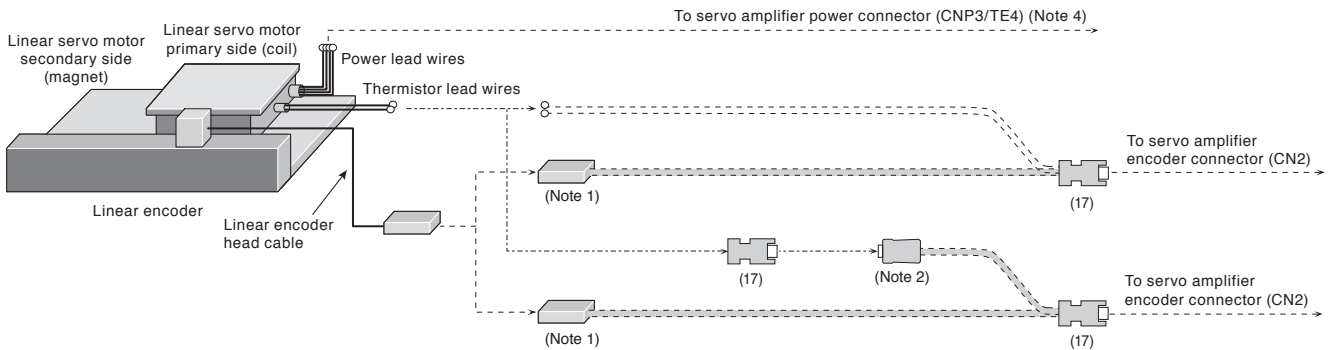

For MR-J4-GF-RJ/B-RJ/A-RJ and LM-F linear servo motor series with a serial linear encoder

### ● When using a junction cable for linear servo motor

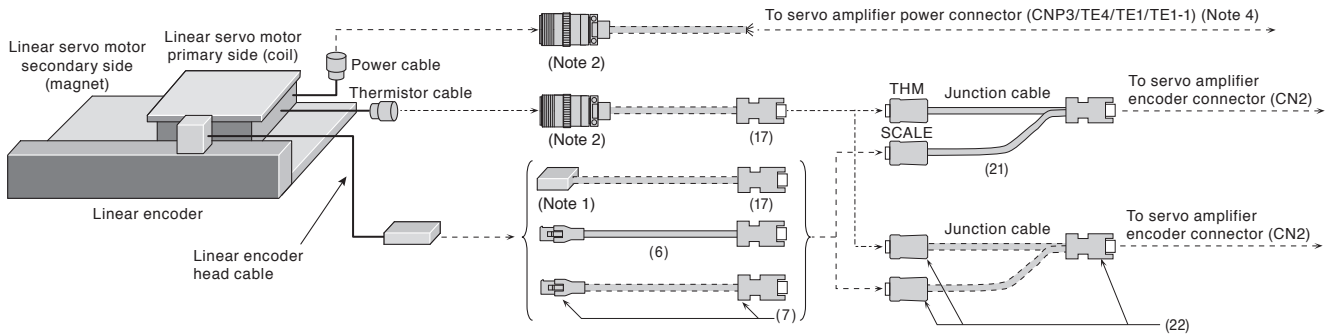

### ● When not using a junction cable for linear servo motor

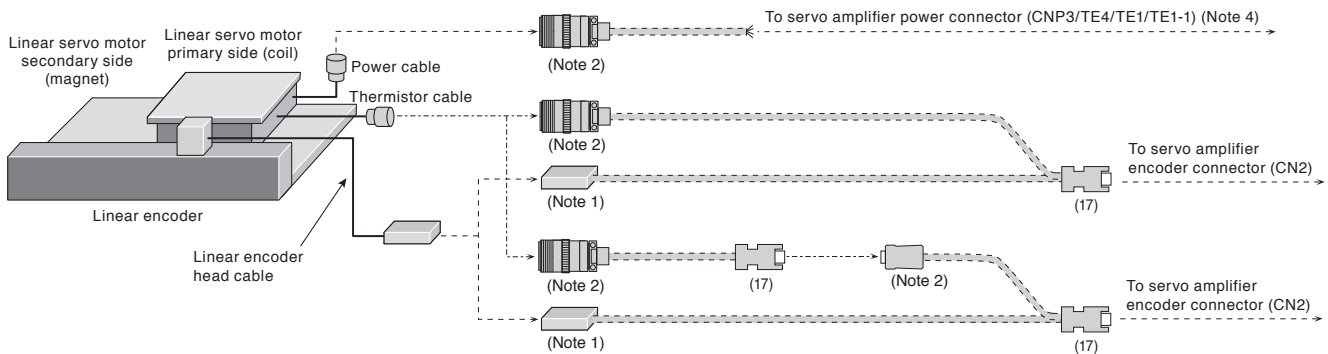

- Notes: 1. Contact the relevant linear encoder manufacturers for connectors to connect with the head cables.  
 2. Refer to "Products on the Market for Servo Motors" in this catalog for these connectors.  
 3. Cables drawn with dashed lines need to be fabricated by user. Refer to relevant Servo Motor Instruction Manual for fabricating the cables.  
 4. The connector for U, V, and W varies depending on the servo amplifier capacities. Refer to the dimensions of the relevant servo amplifier in this catalog for details.

**Configuration Example for Servo Motors** (Note 3)

**GF-RJ B-RJ A-RJ**

For MR-J4-GF-RJ/B-RJ/A-RJ and LM-H3/LM-K2/LM-U2 linear servo motor series with an A/B/Z-phase differential output type linear encoder

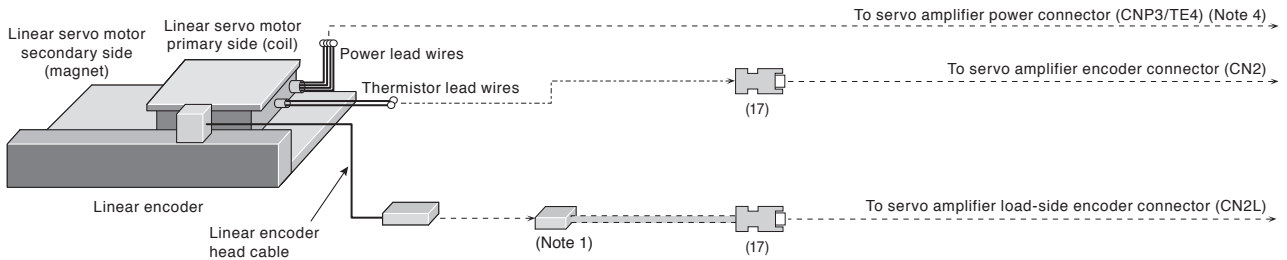

For MR-J4-GF-RJ/B-RJ/A-RJ and LM-F linear servo motor series with an A/B/Z-phase differential output type linear encoder

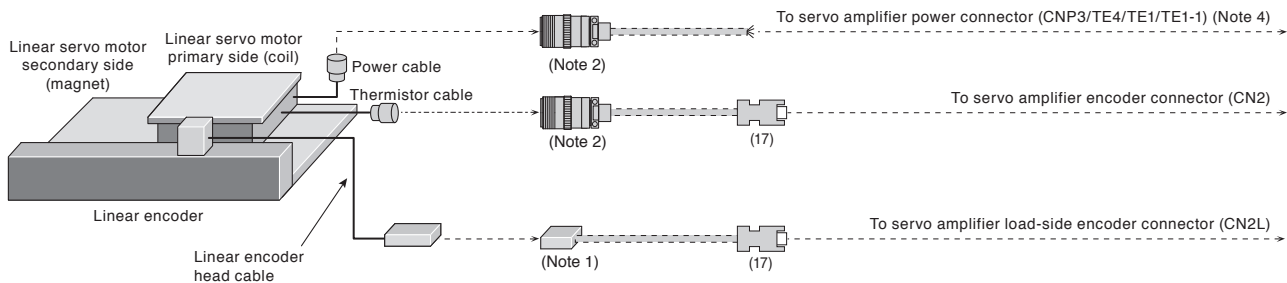

- Notes: 1. Contact the relevant linear encoder manufacturers for connectors to connect with the head cables.  
 2. Refer to "Products on the Market for Servo Motors" in this catalog for these connectors.  
 3. Cables drawn with dashed lines need to be fabricated by user. Refer to relevant Servo Motor Instruction Manual for fabricating the cables.  
 4. The connector for U, V, and W varies depending on the servo amplifier capacities. Refer to the dimensions of the relevant servo amplifier in this catalog for details.

Servo Amplifiers

Rotary Servo Motors

Linear Servo Motors

Direct Drive Motors

Options/Peripheral Equipment

LVS/Wires

Product List

Precautions

# Options/Peripheral Equipment

## Configuration Example for Servo Motors (Note 1)

GF GF-RJ B B-RJ WB A A-RJ

For TM-RG2M/TM-RU2M/TM-RFM direct drive motor series

### ● For incremental system

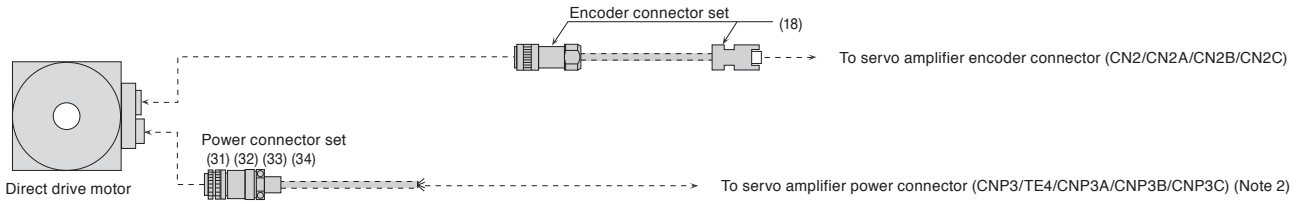

### ● For absolute position detection system

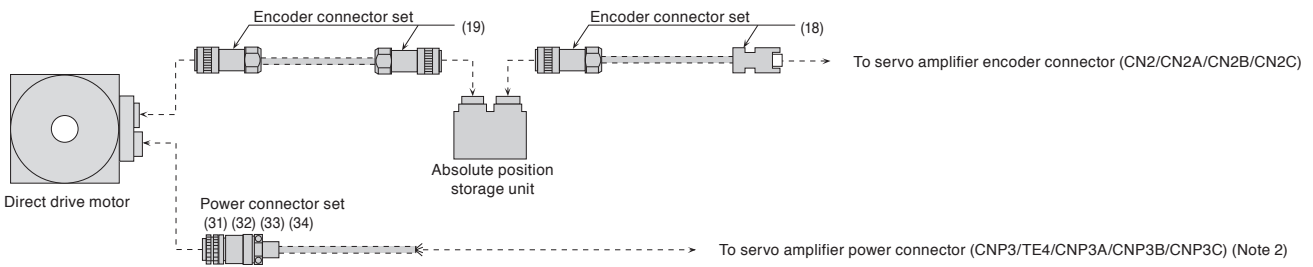







Notes: 1. Cables drawn with dashed lines need to be fabricated by user. Refer to relevant Servo Motor Instruction Manual for fabricating the cables.

2. The connector for U, V, and W varies depending on the servo amplifier capacities. Refer to the dimensions of the relevant servo amplifier in this catalog for details.

## Cables and Connectors for Servo Motor Encoder

Refer to "Details of Option Connectors for Servo Motors" in this catalog for the detailed models.

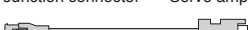
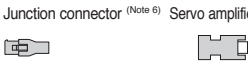
Encoder cables are not subject to Low Voltage Directive (50 V AC to 1000 V AC and 75 V DC to 1500 V DC).

	Item	Model	Cable length	IP rating (Note 1)	Application	Description
(1)	Encoder cable (Note 2) (load-side lead)	MR-J3ENCBL2M-A1-H <sup>*1</sup>	2 m	IP65	For HG-KR/HG-MR (direct connection type)	
		MR-J3ENCBL5M-A1-H <sup>*1</sup>	5 m			
		MR-J3ENCBL10M-A1-H <sup>*1</sup>	10 m			
		MR-J3ENCBL2M-A1-L <sup>*1</sup>	2 m			
		MR-J3ENCBL5M-A1-L <sup>*1</sup>	5 m			
		MR-J3ENCBL10M-A1-L <sup>*1</sup>	10 m			
(2)	Encoder cable (Note 2) (opposite to load-side lead)	MR-J3ENCBL2M-A2-H <sup>*1</sup>	2 m	IP65	For HG-KR/HG-MR (direct connection type)	
		MR-J3ENCBL5M-A2-H <sup>*1</sup>	5 m			
		MR-J3ENCBL10M-A2-H <sup>*1</sup>	10 m			
		MR-J3ENCBL2M-A2-L <sup>*1</sup>	2 m			
		MR-J3ENCBL5M-A2-L <sup>*1</sup>	5 m			
		MR-J3ENCBL10M-A2-L <sup>*1</sup>	10 m			
(3)	Encoder cable (Note 2) (load-side lead)	MR-J3JCBL03M-A1-L <sup>*1</sup>	0.3 m	IP20	For HG-KR/HG-MR (junction type)	
(4)	Encoder cable (Note 2) (opposite to load-side lead)	MR-J3JCBL03M-A2-L <sup>*1</sup>	0.3 m	IP20	For HG-KR/HG-MR (junction type)	 <p>Use this in combination with (5) or (7).</p>
(5)	Encoder cable (Note 2)	MR-EKCBL20M-H <sup>*1</sup>	20 m	IP20	For HG-KR/HG-MR (junction type)	 <p>Use this in combination with (3) or (4).</p>
		MR-EKCBL30M-H (Note 3) <sup>*1</sup>	30 m			
		MR-EKCBL40M-H (Note 3) <sup>*1</sup>	40 m			
		MR-EKCBL50M-H (Note 3) <sup>*1</sup>	50 m			
		MR-EKCBL20M-L <sup>*1</sup>	20 m			
		MR-EKCBL30M-L (Note 3) <sup>*1</sup>	30 m			
(6)	Encoder cable (Note 2, 5)	MR-EKCBL2M-H <sup>*1</sup>	2 m	IP20	For connecting load-side encoder, or linear encoder	
		MR-EKCBL5M-H <sup>*1</sup>	5 m			
(7)	Encoder connector set (Note 5)	MR-ECNM	-	IP20	For HG-KR/HG-MR (junction type) For connecting load-side encoder, or linear encoder	 <p>Use this in combination with (3) or (4) for HG-KR/HG-MR series.</p> <p>Applicable cable Wire size: AWG 26 to 22 Cable OD: 7 mm to 9 mm</p>
(8)	Encoder cable (Note 2) (load-side lead)	MR-J3JSCBL03M-A1-L <sup>*1</sup>	0.3 m	IP65 (Note 4)	For HG-KR/HG-MR (junction type)	
(9)	Encoder cable (Note 2) (opposite to load-side lead)	MR-J3JSCBL03M-A2-L <sup>*1</sup>	0.3 m	IP65 (Note 4)	For HG-KR/HG-MR (junction type)	 <p>Use this in combination with (10) or (11).</p>

Notes: 1. The IP rating indicated is for the connector's protection against ingress of dust and water when coupled to a servo amplifier/servo motor. If the IP rating of the servo amplifier/servo motor differs from that of these connectors, overall IP rating depends on the lowest of all.

2. -H and -L indicate a bending life. -H indicates a long bending life (for moving parts), and -L indicates a standard bending life (for fixed parts).

3. This encoder cable is available in four-wire type. Parameter setting is required to use the four-wire type encoder cable. Refer to relevant Servo Amplifier Instruction Manual for details.

4. The encoder cable is rated IP65 while the junction connector itself is rated IP67.

5. Use MR-EKCBL\_M-H or MR-ECNM to connect to an output cable for AT343A, AT543A-SC or AT545A-SC scales manufactured by Mitutoyo Corporation.

6. The crimping tool (91529-1) manufactured by TE Connectivity Ltd. Company is required. Contact the manufacturer directly.

For unlisted lengths



<sup>\*1</sup>. For unlisted lengths of the cables, please contact Mitsubishi Electric System & Service Co., Ltd. OVERSEAS SERVICE SECTION (Email: osb.webmaster@melsec.jp)

# Options/Peripheral Equipment

## Cables and Connectors for Servo Motor Encoder

Refer to "Details of Option Connectors for Servo Motors" in this catalog for the detailed models.

Encoder cables are not subject to Low Voltage Directive (50 V AC to 1000 V AC and 75 V DC to 1500 V DC).

Item	Model	Cable length	IP rating (Note 1)	Application	Description
(10) Encoder cable (Note 2)	MR-J3ENSCBL2M-H <sup>*1</sup>	2 m	IP67	For HG-KR/HG-MR (junction type) For HG-SR/ HG-JR53, 73, 103, 153, 203, 353, 503, 534, 734, 1034, 1534, 2034, 3534, 5034, HG-RR/HG-UR (direct connection type)	Junction connector or encoder connector      Servo amplifier connector  Use this in combination with (8) or (9) for HG-KR/HG-MR series.
	MR-J3ENSCBL5M-H <sup>*1</sup>	5 m			
	MR-J3ENSCBL10M-H <sup>*1</sup>	10 m			
	MR-J3ENSCBL20M-H <sup>*1</sup>	20 m			
	MR-J3ENSCBL30M-H <sup>*1</sup>	30 m			
	MR-J3ENSCBL40M-H <sup>*1</sup>	40 m			
	MR-J3ENSCBL50M-H <sup>*1</sup>	50 m			
	MR-J3ENSCBL2M-L <sup>*1</sup>	2 m			
	MR-J3ENSCBL5M-L <sup>*1</sup>	5 m			
	MR-J3ENSCBL10M-L <sup>*1</sup>	10 m			
	MR-J3ENSCBL20M-L <sup>*1</sup>	20 m			
MR-J3ENSCBL30M-L <sup>*1</sup>	30 m				
(11) Encoder connector set (Note 5) (one-touch connection type)	MR-J3SCNS	-	IP67	For HG-KR/HG-MR (junction type) For HG-SR/ HG-JR53, 73, 103, 153, 203, 353, 503, 534, 734, 1034, 1534, 2034, 3534, 5034, HG-RR/HG-UR (direct connection type) (straight type)	Junction connector or encoder connector      Servo amplifier connector  Use this in combination with (8) or (9) for HG-KR/HG-MR series.
(12) Encoder connector set (Note 3, 5) (screw type)	MR-ENCNS2 <sup>*2</sup>	-	IP67	For HG-KR/HG-MR (junction type) For HG-SR/ HG-JR53, 73, 103, 153, 203, 353, 503, 534, 734, 1034, 1534, 2034, 3534, 5034, HG-RR/HG-UR (direct connection type) (straight type)	Applicable cable Wire size: 0.5 mm <sup>2</sup> (AWG 20) or smaller Cable OD: 5.5 mm to 9.0 mm (Note 4)
(13) Encoder connector set (Note 5) (one-touch connection type)	MR-J3SCNSA <sup>*2</sup>	-	IP67	For HG-SR/ HG-JR53, 73, 103, 153, 203, 353, 503, 703, 903, 534, 734, 1034, 1534, 2034, 3534, 5034, 7034, 9034/ HG-RR/HG-UR (angle type)	Encoder connector      Servo amplifier connector  Applicable cable Wire size: 0.5 mm <sup>2</sup> (AWG 20) or smaller Cable OD: 5.5 mm to 9.0 mm (Note 4)
(14) Encoder connector set (Note 3, 5) (screw type)	MR-ENCNS2A <sup>*2</sup>	-	IP67	For HG-SR/ HG-JR53, 73, 103, 153, 203, 353, 503, 703, 903, 534, 734, 1034, 1534, 2034, 3534, 5034, 7034, 9034/ HG-RR/HG-UR (angle type)	Applicable cable Wire size: 0.5 mm <sup>2</sup> (AWG 20) or smaller Cable OD: 5.5 mm to 9.0 mm (Note 4)

Notes: 1. The IP rating indicated is for the connector's protection against ingress of dust and water when coupled to a servo amplifier/servo motor. If the IP rating of the servo amplifier/servo motor differs from that of these connectors, overall IP rating depends on the lowest of all.

2. -H and -L indicate a bending life. -H indicates a long bending life (for moving parts), and -L indicates a standard bending life (for fixed parts).

3. A screw thread is cut on the encoder connector of HG-SR/HG-JR/HG-RR/HG-UR series, and the screw type connector can be used.

4. Cable clamps and bushings for cable OD of 5.5 mm to 7.5 mm and of 7.0 mm to 9.0 mm are included in the set.

5. The connector contains a plug and contacts. Using contacts for other plugs may damage the connector. Be sure to use the enclosed contacts.

For unlisted lengths and fabricating cables



\*1. For unlisted lengths of the cables, please contact Mitsubishi Electric System & Service Co., Ltd. OVERSEAS SERVICE SECTION (Email: osb.webmaster@melsc.jp)

\*2. For fabricating encoder cables with these connectors, please contact Mitsubishi Electric System & Service Co., Ltd. OVERSEAS SERVICE SECTION (Email: osb.webmaster@melsc.jp)

## Cables and Connectors for Servo Motor Encoder

Refer to "Details of Option Connectors for Servo Motors" in this catalog for the detailed models.

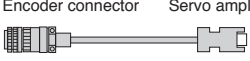
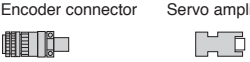
Encoder cables are not subject to Low Voltage Directive (50 V AC to 1000 V AC and 75 V DC to 1500 V DC).

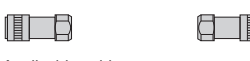
Item	Model	Cable length	IP rating (Note 1)	Application	Description
(15) Encoder cable (Note 2, 3)	MR-ENECBL2M-H-MTH	2 m	IP67	For HG-JR601, 801, 12K1, 15K1, 20K1, 25K1, 30K1, 37K1, 701M, 11K1M, 15K1M, 22K1M, 30K1M, 37K1M, 6014, 8014, 12K14, 15K14, 20K14, 25K14, 30K14, 37K14, 701M4, 11K1M4, 15K1M4, 22K1M4, 30K1M4, 37K1M4, 45K1M4, 55K1M4	
	MR-ENECBL5M-H-MTH	5 m			
	MR-ENECBL10M-H-MTH	10 m			
	MR-ENECBL20M-H-MTH	20 m			
	MR-ENECBL30M-H-MTH	30 m			
	MR-ENECBL40M-H-MTH	40 m			
	MR-ENECBL50M-H-MTH	50 m			
(16) Encoder connector set	MR-ENECNS	-	IP67	For HG-JR601, 801, 12K1, 15K1, 20K1, 25K1, 30K1, 37K1, 701M, 11K1M, 15K1M, 22K1M, 30K1M, 37K1M, 6014, 8014, 12K14, 15K14, 20K14, 25K14, 30K14, 37K14, 701M4, 11K1M4, 15K1M4, 22K1M4, 30K1M4, 37K1M4, 45K1M4, 55K1M4, 110K24W0C, 150K24W0C, 180K24W0C, 200K24W0C, 220K24W0C	 Applicable cable Wire size: 0.3 mm <sup>2</sup> to 1.25 mm <sup>2</sup> (AWG 22 to 16) Cable OD: 6.8 mm to 10 mm
(17) Encoder connector set	MR-J3CN2	-	-	For connecting load-side encoder, linear encoder, or thermistor	
(18) Encoder connector set	MR-J3DDCNS	-	IP67	For TM-RG2M/TM-RU2M/TM-RFM (connecting direct drive motor and servo amplifier, or absolute position storage unit and servo amplifier)	 Applicable cable Wire size: 0.25 mm <sup>2</sup> to 0.5 mm <sup>2</sup> (AWG 23 to 20) Cable OD: 7.8 mm to 8.2 mm
(19) Encoder connector set	MR-J3DDSPS	-	IP67	For TM-RG2M/TM-RU2M/TM-RFM (connecting direct drive motor and absolute position storage unit)	 Applicable cable Wire size: 0.25 mm <sup>2</sup> to 0.5 mm <sup>2</sup> (AWG 23 to 20) Cable OD: 7.8 mm to 8.2 mm

Notes: 1. The IP rating indicated is for the connector's protection against ingress of dust and water when coupled to a servo amplifier/servo motor/absolute position storage unit.

If the IP rating of the servo amplifier/servo motor/absolute position storage unit differs from that of these connectors, overall IP rating depends on the lowest of all.

2. -H and -L indicate a bending life. -H indicates a long bending life (for moving parts), and -L indicates a standard bending life (for fixed parts).





3. This encoder cable includes thermistor signal wires.

# Options/Peripheral Equipment

## Cables and Connectors for Servo Motor Encoder

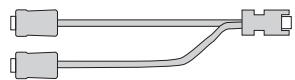
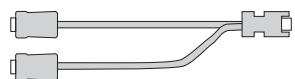
Refer to "Details of Option Connectors for Servo Motors" in this catalog for the detailed models.

Encoder cables are not subject to Low Voltage Directive (50 V AC to 1000 V AC and 75 V DC to 1500 V DC).

Item	Model	Cable length	IP rating (Note 3)	Application	Description
(20) Junction cable for fully closed loop control (Note 2)	MR-J4FCCBL03M	0.3 m	-	For branching load-side encoder	Junction connector Servo amplifier connector 
(21) Junction cable for linear servo motor (Note 2)	MR-J4THCBL03M	0.3 m	-	For branching thermistor	Junction connector Servo amplifier connector 
(22) Connector set	MR-J3THMCN2	-	-	For branching load-side encoder or branching thermistor	Junction connector Servo amplifier connector 
(23) Encoder cable	MR-J3W03ENCBL1M-A-H *1	1 m	-	For HG-AK	Encoder connector Servo amplifier connector 
	MR-J3W03ENCBL2M-A-H *1	2 m			
	MR-J3W03ENCBL5M-A-H *1	5 m			
	MR-J3W03ENCBL10M-A-H *1	10 m			
	MR-J3W03ENCBL20M-A-H *1	20 m			
	MR-J3W03ENCBL30M-A-H *1	30 m			
(24) Encoder connector set (Qty: 2 sets)	MR-J3W03CN2-2P *2	-	-	For HG-AK	Encoder connector (Note 1) Servo amplifier connector (Note 1) 
(25) Encoder connector set (Qty: 20 sets)	MR-J3W03CN2-20P *2	-	-	For HG-AK	Applicable cable Wire size: 0.2 mm <sup>2</sup> to 0.38 mm <sup>2</sup> (AWG 24 to 22) Insulator OD: 1.11 mm to 1.53 mm
(26) Encoder cable (Note 4)	MR-ENE4CBL5M-H-MTH	5 m	IP67	For HG-JR110K24W0C, 150K24W0C, 180K24W0C, 200K24W0C, 220K24W0C	Encoder connector Drive unit connector 
	MR-ENE4CBL10M-H-MTH	10 m			
	MR-ENE4CBL20M-H-MTH	20 m			
	MR-ENE4CBL30M-H-MTH	30 m			
	MR-ENE4CBL40M-H-MTH	40 m			
	MR-ENE4CBL50M-H-MTH	50 m			

Notes: 1. The crimping tool (1762846-1) manufactured by TE Connectivity Ltd. Company is required for the servo amplifier connector, and the crimping tool (YRS-8861) manufactured by J.S.T Mfg. Co., Ltd is required for the encoder connector. Contact the manufacturer directly.

2. Servo system will not operate correctly when the junction cables for fully closed loop control and for linear servo motor are used mistakenly or interchangeably. Make sure of the model before placing an order.

3. The IP rating indicated is for the connector's protection against ingress of dust and water when coupled to a servo amplifier/servo motor. If the IP rating of the servo amplifier/servo motor differs from that of these connectors, overall IP rating depends on the lowest of all.

4. This encoder cable includes thermistor signal wires.









For unlisted lengths and fabricating cables

\*1. For unlisted lengths of the cables, please contact Mitsubishi Electric System & Service Co., Ltd. OVERSEAS SERVICE SECTION (Email: [osb.webmaster@melsc.jp](mailto:osb.webmaster@melsc.jp))  
\*2. For fabricating encoder cables with these connectors, please contact Mitsubishi Electric System & Service Co., Ltd. OVERSEAS SERVICE SECTION (Email: [osb.webmaster@melsc.jp](mailto:osb.webmaster@melsc.jp))



## Cables and Connectors for Servo Motor Power

Refer to "Details of Option Connectors for Servo Motors" in this catalog for the detailed models.

Item	Model	Cable length	IP rating (Note 1)	Application	Description
(27) Power cable (Note 2) (load-side lead)	MR-PWS1CBL2M-A1-H *1	2 m	IP65	For HG-KR/HG-MR (direct connection type)	 Power connector Lead-out
	MR-PWS1CBL5M-A1-H *1	5 m			
	MR-PWS1CBL10M-A1-H *1	10 m			
	MR-PWS1CBL2M-A1-L *1 (Note 3)	2 m			
	MR-PWS1CBL5M-A1-L *1 (Note 3)	5 m			
	MR-PWS1CBL10M-A1-L *1 (Note 3)	10 m			
(28) Power cable (Note 2) (opposite to load-side lead)	MR-PWS1CBL2M-A2-H *1	2 m	IP65	For HG-KR/HG-MR (direct connection type)	 Power connector Lead-out  * The cable is not shielded.
	MR-PWS1CBL5M-A2-H *1	5 m			
	MR-PWS1CBL10M-A2-H *1	10 m			
	MR-PWS1CBL2M-A2-L *1 (Note 3)	2 m			
	MR-PWS1CBL5M-A2-L *1 (Note 3)	5 m			
	MR-PWS1CBL10M-A2-L *1 (Note 3)	10 m			
(29) Power cable (Note 2) (load-side lead)	MR-PWS2CBL03M-A1-L	0.3 m	IP55	For HG-KR/HG-MR (junction type)	 Power connector Lead-out * The cable is not shielded.
(30) Power cable (Note 2) (opposite to load-side lead)	MR-PWS2CBL03M-A2-L	0.3 m	IP55	For HG-KR/HG-MR (junction type)	 Power connector Lead-out * The cable is not shielded.
(31) Power connector set	MR-PWCNF *2 (Note 4)	-	IP67	For TM-RG2M_ TM-RU2M_ TM-RFM_C20/ TM-RFM_E20	 Power connector  Applicable cable Wire size: 0.3 mm <sup>2</sup> to 1.25 mm <sup>2</sup> (AWG 22 to 16) Cable OD: 8.3 mm to 11.3 mm
(32) Power connector set	MR-PWCNS4 *2	-	IP67	For HG-SR51, 81, 52, 102, 152, 524, 1024, 1524/ HG-JR53, 73, 103, 153, 203, 534, 734, 1034, 1534, 2034, 3534, 5034/ TM-RFM_G20	 Power connector  Applicable cable Wire size: 2 mm <sup>2</sup> to 3.5 mm <sup>2</sup> (AWG 14 to 12) Cable OD: 10.5 mm to 14.1 mm
(33) Power connector set	MR-PWCNS5 *2	-	IP67	For HG-SR121, 201, 301, 202, 352, 502, 2024, 3524, 5024/ HG-JR353, 503/ TM-RFM040J10, TM-RFM120J10	 Power connector  Applicable cable Wire size: 5.5 mm <sup>2</sup> to 8 mm <sup>2</sup> (AWG 10 to 8) Cable OD: 12.5 mm to 16 mm
(34) Power connector set	MR-PWCNS3 *2	-	IP67	For HG-SR421, 702, 7024/ HG-JR703, 903, 601, 801, 12K1, 701M, 11K1M, 15K1M, 7034, 9034, 6014, 8014, 12K14, 701M4, 11K1M4, 15K1M4/ TM-RFM240J10	 Power connector  Applicable cable Wire size: 14 mm <sup>2</sup> to 22 mm <sup>2</sup> (AWG 6 to 4) Cable OD: 22 mm to 23.8 mm

Notes: 1. The IP rating indicated is for the connector's protection against ingress of dust and water when coupled to a servo amplifier/servo motor. If the IP rating of the servo amplifier/servo motor differs from that of these connectors, overall IP rating depends on the lowest of all.

2. -H and -L indicate a bending life. -H indicates a long bending life (for moving parts), and -L indicates a standard bending life (for fixed parts).

3. Shielded power cable MR-PWS3CBL\_M-A\_-L is also available. Contact your local sales office.

4. When using TM-RG2M\_/TM-RU2M\_/TM-RFM\_C20/TM-RFM\_E20 for a machine that is required to comply with UL/CSA standards, do not use MR-PWCNF. Use a cable (SC-PWFCBL\_M-L or SC-PWFCBL\_M-H) manufactured by Mitsubishi Electric System & Service Co., Ltd. For details of SC-PWFCBL\_M-L or SC-PWFCBL\_M-H, please contact Mitsubishi Electric System & Service Co., Ltd. OVERSEAS SERVICE SECTION.  
(Email: osb.webmaster@melsc.jp)

For unlisted lengths and fabricating cables





\*1. For unlisted lengths of the cables, please contact Mitsubishi Electric System & Service Co., Ltd. OVERSEAS SERVICE SECTION (Email: osb.webmaster@melsc.jp)

\*2. For fabricating servo motor power cables or electromagnetic brake cables, please contact Mitsubishi Electric System & Service Co., Ltd. OVERSEAS SERVICE SECTION (Email: osb.webmaster@melsc.jp)

## Options/Peripheral Equipment

### Cables and Connectors for Servo Motor Power

Refer to "Details of Option Connectors for Servo Motors" in this catalog for the detailed models.

Item	Model	Cable length	IP rating (Note 1)	Application	Description
(35) Power connector set	MR-PWCNS1 <sup>*2</sup>	-	IP67	For HG-RR103, 153, 203/ HG-UR72, 152	Power connector  Applicable cable Wire size: 2 mm <sup>2</sup> to 3.5 mm <sup>2</sup> (AWG 14 to 12) Cable OD: 9.5 mm to 13 mm
(36) Power connector set	MR-PWCNS2 <sup>*2</sup>	-	IP67	For HG-RR353, 503/ HG-UR202, 352, 502	Power connector  Applicable cable Wire size: 5.5 mm <sup>2</sup> to 8 mm <sup>2</sup> (AWG 10 to 8) Cable OD: 13 mm to 15.5 mm
(37) Servo motor power cable (for standard servo motor)	MR-J4W03PWCBL1M-H <sup>*1</sup>	1 m	-	For HG-AK	Power connector 
	MR-J4W03PWCBL2M-H <sup>*1</sup>	2 m			
	MR-J4W03PWCBL5M-H <sup>*1</sup>	5 m			
	MR-J4W03PWCBL10M-H <sup>*1</sup>	10 m			
	MR-J4W03PWCBL20M-H <sup>*1</sup>	20 m			
	MR-J4W03PWCBL30M-H <sup>*1</sup>	30 m			
(38) Servo motor power cable (for the servo motor with electromagnetic brake)	MR-J4W03PWBRCL1M-H <sup>*1</sup>	1 m	-	For HG-AK	Power connector 
	MR-J4W03PWBRCL2M-H <sup>*1</sup>	2 m			
	MR-J4W03PWBRCL5M-H <sup>*1</sup>	5 m			
	MR-J4W03PWBRCL10M-H <sup>*1</sup>	10 m			
	MR-J4W03PWBRCL20M-H <sup>*1</sup>	20 m			
	MR-J4W03PWBRCL30M-H <sup>*1</sup>	30 m			
(39) Servo motor power connector set (Qty: 2 pcs)	MR-J4W03CNP2-2P <sup>*2</sup>	-	-	For HG-AK	Power connector (Note 2) 
(40) Servo motor power connector set (Qty: 20 pcs)	MR-J4W03CNP2-20P <sup>*2</sup>	-	-		Applicable cable Wire size: 0.34 mm <sup>2</sup> to 0.75 mm <sup>2</sup> (AWG 22 to 19) Insulator OD: 1.4 mm to 1.9 mm

### Cables and Connectors for Servo Motor Cooling Fan Power

Refer to "Details of Option Connectors for Servo Motors" in this catalog for the detailed models.

Item	Model	Cable length	IP rating (Note 1)	Application	Description
(41) Cooling fan power connector set	MR-PWCNF <sup>*2</sup>	-	IP67	For HG-JR15K1, 20K1, 25K1, 30K1, 37K1, 22K1M, 30K1M, 37K1M, 15K14, 20K14, 25K14, 30K14, 37K14, 22K1M4, 30K1M4, 37K1M4, 45K1M4, 55K1M4	Power connector  Applicable cable Wire size: 0.3 mm <sup>2</sup> to 1.25 mm <sup>2</sup> (AWG 22 to 16) Cable OD: 8.3 mm to 11.3 mm

Notes: 1. The IP rating indicated is for the connector's protection against ingress of dust and water when coupled to a servo amplifier/servo motor. If the IP rating of the servo amplifier/servo motor differs from that of these connectors, overall IP rating depends on the lowest of all.







2. The crimping tool (YRF-1120) manufactured by J.S.T. Mfg. Co., Ltd is required. Contact the manufacturer directly.

For unlisted lengths and fabricating cables

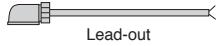
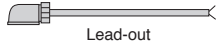
\*1. For unlisted lengths of the cables, please contact Mitsubishi Electric System & Service Co., Ltd. OVERSEAS SERVICE SECTION (Email: osb.webmaster@melsc.jp)  
\*2. For fabricating servo motor power cables or electromagnetic brake cables, please contact Mitsubishi Electric System & Service Co., Ltd. OVERSEAS SERVICE SECTION (Email: osb.webmaster@melsc.jp)

## Cables and Connectors for Servo Motor Electromagnetic Brake

Refer to "Details of Option Connectors for Servo Motors" in this catalog for the detailed models.

Item	Model	Cable length	IP rating (Note 1)	Application	Description
(42) Electromagnetic brake cable (Note 2) (load-side lead)	MR-BKS1CBL2M-A1-H <sup>*1</sup>	2 m	IP65	For HG-KR/HG-MR (direct connection type)	 Electromagnetic brake connector Lead-out
	MR-BKS1CBL5M-A1-H <sup>*1</sup>	5 m			
	MR-BKS1CBL10M-A1-H <sup>*1</sup>	10 m			
	MR-BKS1CBL2M-A1-L <sup>*1</sup>	2 m			
	MR-BKS1CBL5M-A1-L <sup>*1</sup>	5 m			
	MR-BKS1CBL10M-A1-L <sup>*1</sup>	10 m			
(43) Electromagnetic brake cable (Note 2) (opposite to load-side lead)	MR-BKS1CBL2M-A2-H <sup>*1</sup>	2 m	IP65	For HG-KR/HG-MR (direct connection type)	 Lead-out  * The cable is not shielded.
	MR-BKS1CBL5M-A2-H <sup>*1</sup>	5 m			
	MR-BKS1CBL10M-A2-H <sup>*1</sup>	10 m			
	MR-BKS1CBL2M-A2-L <sup>*1</sup>	2 m			
	MR-BKS1CBL5M-A2-L <sup>*1</sup>	5 m			
	MR-BKS1CBL10M-A2-L <sup>*1</sup>	10 m			
(44) Electromagnetic brake cable (Note 2) (load-side lead)	MR-BKS2CBL03M-A1-L	0.3 m	IP55	For HG-KR/HG-MR (junction type)	 Electromagnetic brake connector Lead-out
(45) Electromagnetic brake cable (Note 2) (opposite to load-side lead)	MR-BKS2CBL03M-A2-L	0.3 m	IP55	For HG-KR/HG-MR (junction type)	* The cable is not shielded.
(46) Electromagnetic brake connector set (Note 4) (one-touch connection type)	MR-BKCNS1 <sup>*2</sup>	-	IP67	For HG-SR/ HG-JR53B, 73B, 103B, 153B, 203B, 353B, 503B, 703B, 903B, 534B, 734B, 1034B, 1534B, 2034B, 3534B, 5034B, 7034B, 9034B (straight type)	 Electromagnetic brake connector  Applicable cable Wire size: 1.25 mm <sup>2</sup> (AWG 16) or smaller Cable OD: 9.0 mm to 11.6 mm
(47) Electromagnetic brake connector set (Note 3, 4) (screw type)	MR-BKCNS2 <sup>*2</sup>	-	IP67	For HG-SR/ HG-JR53B, 73B, 103B, 153B, 203B, 353B, 503B, 703B, 903B, 534B, 734B, 1034B, 1534B, 2034B, 3534B, 5034B, 7034B, 9034B (angle type)	 Electromagnetic brake connector  Applicable cable Wire size: 1.25 mm <sup>2</sup> (AWG 16) or smaller Cable OD: 9.0 mm to 11.6 mm
(48) Electromagnetic brake connector set (Note 4) (one-touch connection type)	MR-BKCNS1A <sup>*2</sup>	-	IP67	For HG-SR/ HG-JR53B, 73B, 103B, 153B, 203B, 353B, 503B, 703B, 903B, 534B, 734B, 1034B, 1534B, 2034B, 3534B, 5034B, 7034B, 9034B (angle type)	 Electromagnetic brake connector  Applicable cable Wire size: 0.3 mm <sup>2</sup> to 1.25 mm <sup>2</sup> (AWG 22 to 16) Cable OD: 5.0 mm to 8.3 mm
(49) Electromagnetic brake connector set (Note 3, 4) (screw type)	MR-BKCNS2A <sup>*2</sup>	-	IP67	For HG-SR/ HG-JR53B, 73B, 103B, 153B, 203B, 353B, 503B, 703B, 903B, 534B, 734B, 1034B, 1534B, 2034B, 3534B, 5034B, 7034B, 9034B (angle type)	 Electromagnetic brake connector  Applicable cable Wire size: 0.3 mm <sup>2</sup> to 1.25 mm <sup>2</sup> (AWG 22 to 16) Cable OD: 5.0 mm to 8.3 mm
(50) Electromagnetic brake connector set	MR-BKCN	-	IP67	For HG-JR601B, 801B, 12K1B, 701MB, 11K1MB, 15K1MB, 6014B, 8014B, 12K14B, 701M4B, 11K1M4B, 15K1M4B/ HG-UR202B, 352B, 502B (straight type)	 Electromagnetic brake connector  Applicable cable Wire size: 0.3 mm <sup>2</sup> to 1.25 mm <sup>2</sup> (AWG 22 to 16) Cable OD: 5.0 mm to 8.3 mm

Notes: 1. The IP rating indicated is for the connector's protection against ingress of dust and water when coupled to a servo amplifier/servo motor. If the IP rating of the servo amplifier/servo motor differs from that of these connectors, overall IP rating depends on the lowest of all.

2. -H and -L indicate a bending life. -H indicates a long bending life (for moving parts), and -L indicates a standard bending life (for fixed parts).

3. A screw thread is cut on the electromagnetic brake connector of HG-SR/HG-JR series, and the screw type connector can be used.



4. The connector contains a plug and contacts. Using contacts for other plugs may damage the connector. Be sure to use the enclosed contacts.



For unlisted lengths and fabricating cables



*1. For unlisted lengths of the cables, please contact Mitsubishi Electric System & Service Co., Ltd. OVERSEAS SERVICE SECTION (Email: osb.webmaster@melsc.jp)
*2. For fabricating servo motor power cables or electromagnetic brake cables, please contact Mitsubishi Electric System & Service Co., Ltd. OVERSEAS SERVICE SECTION (Email: osb.webmaster@melsc.jp)



# Options/Peripheral Equipment



## Details of Option Connectors for Servo Motors



Model	Encoder connector	Servo amplifier connector
MR-J3ENCBL_M-A1-H (Note 2) MR-J3ENCBL_M-A1-L (Note 2) MR-J3ENCBL_M-A2-H (Note 2) MR-J3ENCBL_M-A2-L (Note 2)	 2174053-1 (TE Connectivity Ltd. Company)	 Receptacle: 36210-0100PL Shell kit: 36310-3200-008 (3M) or Connector set: 54599-1019 (Molex, LLC)

Model	Encoder connector	Junction connector
MR-J3JCBLO3M-A1-L (Note 2) MR-J3JCBLO3M-A2-L (Note 2)	 2174053-1 (TE Connectivity Ltd. Company)	 Contact: 1473226-1 (with ring) Housing: 1-172169-9 Cable clamp: 316454-1 (TE Connectivity Ltd. Company)

Model	Junction connector	Servo amplifier connector
MR-EKCBL_M-H MR-EKCBL_M-L MR-ECNM	 Housing: 1-172161-9 Connector pin: 170359-1 (TE Connectivity Ltd. Company) or an equivalent product Cable clamp: MT1-0002 (Toa Electric Industrial Co., Ltd.)	 Receptacle: 36210-0100PL Shell kit: 36310-3200-008 (3M) or Connector set: 54599-1019 (Molex, LLC)









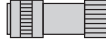

Model	Encoder connector	Junction connector
MR-J3JSCBLO3M-A1-L (Note 2) MR-J3JSCBLO3M-A2-L (Note 2)	 2174053-1 (TE Connectivity Ltd. Company)	 Cable receptacle: CMV1-CR10P-M1 (DDK Ltd.)

Model	Encoder connector	Servo amplifier connector
MR-J3ENSCBL_M-H (Note 2) MR-J3ENSCBL_M-L (Note 2)	 For 10 m or shorter cable Straight plug: CMV1-SP10S-M1 Socket contact: CMV1-#22ASC-C1-100 For 20 m or longer cable Straight plug: CMV1-SP10S-M1 (long bending life) CMV1-SP10S-M2 (standard) Socket contact: CMV1-#22ASC-C2-100 (DDK Ltd.)	 Receptacle: 36210-0100PL Shell kit: 36310-3200-008 (3M) or Connector set: 54599-1019 (Molex, LLC)

Model	Junction connector/encoder connector	Servo amplifier connector
MR-J3SCNS (Note 2, 3)	 Straight plug: CMV1-SP10S-M2 (Note 1) Socket contact: CMV1-#22ASC-S1-100 (DDK Ltd.)	 Receptacle: 36210-0100PL Shell kit: 36310-3200-008 (3M) or Connector set: 54599-1019 (Molex, LLC)

- Notes: 1. Cable clamps and bushings for cable OD of 5.5 mm to 7.5 mm and of 7.0 mm to 9.0 mm are included in the set.  
2. The cable or the connector set may contain connectors of different shapes. However, these connectors are all usable.  
3. The connector contains a plug and contacts. Using contacts for other plugs may damage the connector. Be sure to use the enclosed contacts.

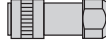









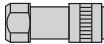

## Details of Option Connectors for Servo Motors

Model	Encoder connector	Servo amplifier connector
MR-ENCNS2 (Note 3)	 Straight plug: CMV1S-SP10S-M2 (Note 1) Socket contact: CMV1-#22ASC-S1-100 (DDK Ltd.)	 Receptacle: 36210-0100PL Shell kit: 36310-3200-008 (3M) or Connector set: 54599-1019 (Molex, LLC)
MR-J3SCNSA (Note 2, 3)	 Angle plug: CMV1-AP10S-M2 (Note 1) Socket contact: CMV1-#22ASC-S1-100 (DDK Ltd.)	 Receptacle: 36210-0100PL Shell kit: 36310-3200-008 (3M) or Connector set: 54599-1019 (Molex, LLC)
MR-ENCNS2A (Note 3)	 Angle plug: CMV1S-AP10S-M2 (Note 1) Socket contact: CMV1-#22ASC-S1-100 (DDK Ltd.)	 Receptacle: 36210-0100PL Shell kit: 36310-3200-008 (3M) or Connector set: 54599-1019 (Molex, LLC)
MR-ENECBL_M-H-MTH MR-ENECNS	 Plug: D/MS3106A20-29S(D190) Backshell: CE02-20BS-S-D (straight) Cable clamp: CE3057-12A-3-D (DDK Ltd.)	 Receptacle: 36210-0100PL Shell kit: 36310-3200-008 (3M) or Connector set: 54599-1019 (Molex, LLC)
MR-J3CN2	 Receptacle: 36210-0100PL Shell kit: 36310-3200-008 (3M)	
MR-J3DDCNS	 Plug: RM15WTPZK-12S Cord clamp: JR13WCCA-8(72) (Hirose Electric Co., Ltd.)	 Receptacle: 36210-0100PL Shell kit: 36310-3200-008 (3M) or Connector set: 54599-1019 (Molex, LLC)

- Notes: 1. Cable clamps and bushings for cable OD of 5.5 mm to 7.5 mm and of 7.0 mm to 9.0 mm are included in the set.  
 2. The cable or the connector set may contain connectors of different shapes. However, these connectors are all usable.  
 3. The connector contains a plug and contacts. Using contacts for other plugs may damage the connector. Be sure to use the enclosed contacts.











# Options/Peripheral Equipment

## Details of Option Connectors for Servo Motors

Model	Encoder connector	Absolute position storage unit connector
MR-J3DDSPS	 Plug: RM15WTPZK-12S Cord clamp: JR13WCCA-8(72) (Hirose Electric Co., Ltd.)	 Plug: RM15WTPZ-12P(72) Cord clamp: JR13WCCA-8(72) (Hirose Electric Co., Ltd.)
Model	Junction connector	Servo amplifier connector
MR-J4FCCBL03M MR-J4THCBL03M MR-J3THMCN2	 Plug: 36110-3000FD Shell kit: 36310-F200-008 (3M)	 Receptacle: 36210-0100PL Shell kit: 36310-3200-008 (3M)
Model	Encoder connector	Servo amplifier connector
MR-J3W03ENCBL_M-A-H MR-J3W03CN2-2P MR-J3W03CN2-20P	 Tab housing: J21DPM-10V-KX Tab contact: SJ2M-01GF-M1.0N (J.S.T Mfg. Co., Ltd)	 Receptacle housing: 1-1827862-5 Receptacle contact: 1827587-2 (TE Connectivity Ltd. Company)
Model	Encoder connector	Drive unit connector
MR-ENE4CBLM-H-MTH	 Plug: D/MS3106A-20-29S-BSS (with waterproof straight backshell) Cable clamp: CE3057-12A-3-D (DDK Ltd.)	 Receptacle: 36210-0100PL Shell kit: 36310-3200-008 (3M)
Model	Power connector	
MR-PWS1CBL_M-A1-H (Note 1) MR-PWS1CBL_M-A1-L (Note 1) MR-PWS1CBL_M-A2-H (Note 1) MR-PWS1CBL_M-A2-L (Note 1)		Plug: KN4FT04SJ1-R Socket contact: ST-TMH-S-C1B-100-(A534G) (Japan Aviation Electronics Industry, Limited)
Model	Power connector	
MR-PWS2CBL03M-A1-L (Note 1) MR-PWS2CBL03M-A2-L (Note 1)		Plug: KN4FT04SJ2-R Socket contact: ST-TMH-S-C1B-100-(A534G) (Japan Aviation Electronics Industry, Limited)
Model	Power connector/cooling fan power connector	
MR-PWCNF		Plug: CE05-6A14S-2SD-D (straight) (DDK Ltd.) Cable clamp: YSO14-9 to 11 (Daiwa Dengyo Co., Ltd.)
Model	Power connector	
MR-PWCNS4		Plug: CE05-6A18-10SD-D-BSS (straight) Cable clamp: CE3057-10A-1-D (DDK Ltd.)
Model	Power connector	
MR-PWCNS5		Plug: CE05-6A22-22SD-D-BSS (straight) Cable clamp: CE3057-12A-1-D (DDK Ltd.)

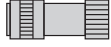
Notes: 1. The cable or the connector set may contain connectors of different shapes. However, these connectors are all usable.

## Details of Option Connectors for Servo Motors

Model	Power connector
MR-PWCNS3	 Plug: CE05-6A32-17SD-D-BSS (straight) Cable clamp: CE3057-20A-1-D (DDK Ltd.)
MR-PWCNS1	 Plug: CE05-6A22-23SD-D-BSS (straight) Cable clamp: CE3057-12A-2-D (DDK Ltd.)
MR-PWCNS2	 Plug: CE05-6A24-10SD-D-BSS (straight) Cable clamp: CE3057-16A-2-D (DDK Ltd.)
MR-J4W03PWCBL_M-H MR-J4W03PWBRCLBL_M-H MR-J4W03CNP2-2P MR-J4W03CNP2-20P	 Tab housing: J21DPM-06V-KX Tab contact: BJ2M-21GF-M1.0N (J.S.T. Mfg. Co., Ltd)
MR-BKS1CBL_M-A1-H MR-BKS1CBL_M-A1-L MR-BKS1CBL_M-A2-H MR-BKS1CBL_M-A2-L	 Plug: JN4FT02SJ1-R Socket contact: ST-TMH-S-C1B-100-(A534G) (Japan Aviation Electronics Industry, Limited)
MR-BKS2CBL03M-A1-L MR-BKS2CBL03M-A2-L	 Plug: JN4FT02SJ2-R Socket contact: ST-TMH-S-C1B-100-(A534G) (Japan Aviation Electronics Industry, Limited)
MR-BKCNS1 (Note 1, 2)	 Straight plug: CMV1-SP2S-L Socket contact: CMV1-#22BSC-S2-100 (DDK Ltd.)
MR-BKCNS2 (Note 2)	 Straight plug: CMV1S-SP2S-L Socket contact: CMV1-#22BSC-S2-100 (DDK Ltd.)
MR-BKCNS1A (Note 1, 2)	 Angle plug: CMV1-AP2S-L Socket contact: CMV1-#22BSC-S2-100 (DDK Ltd.)
MR-BKCNS2A (Note 2)	 Angle plug: CMV1S-AP2S-L Socket contact: CMV1-#22BSC-S2-100 (DDK Ltd.)
MR-BKCN	 Plug: D/MS3106A10SL-4S(D190) (DDK Ltd.) Cable clamp: YSO10-5 to 8 (straight) (Daiwa Dengyo Co., Ltd.)

Notes: 1. The cable or the connector set may contain connectors of different shapes. However, these connectors are all usable.

2. The connector contains a plug and contacts. Using contacts for other plugs may damage the connector. Be sure to use the enclosed contacts.

# Options/Peripheral Equipment

## Products on the Market for Servo Motors

Contact the relevant manufacturers directly. When fabricating a cable with the following connectors, refer to the relevant manufacturers' instruction manuals for wiring and assembling procedures.

### Encoder connector (servo amplifier-side)



Application	Connector (3M)
Servo amplifier CN2 connector	Receptacle: 36210-0100PL Shell kit: 36310-3200-008
	Connector (Molex, LLC)
	54599-1019 (gray)
	54599-1016 (black)

### Encoder connector for HG-KR/HG-MR series **Rotary**



Applicable servo motor	IP rating <sup>(Note 1)</sup>	Connector (TE Connectivity Ltd. Company)	Crimping tool (TE Connectivity Ltd. Company)	Applicable cable example
HG-KR/ HG-MR	IP65	2174053-1	For ground clip: 1596970-1 For receptacle contact: 1596847-1	Wire size: 0.13 mm <sup>2</sup> to 0.33 mm <sup>2</sup> (AWG 26 to 22) Cable OD: 6.8 mm to 7.4 mm Wire example: Fluorine resin wire (Vinyl jacket cable TPE. SVP 70/0.08(AWG#22)-3P KB-2237-2 Bando Densen Co., Ltd. <sup>(Note 2)</sup> or an equivalent product)

### Encoder connector for HG-SR/HG-JR 3000 r/min series/ HG-RR/HG-UR series **Rotary**

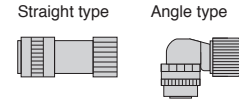

Applicable servo motor	IP rating <sup>(Note 1)</sup>	Connector (DDK Ltd.)				Applicable cable example Cable OD [mm]
		Type	Type of connection	Plug	Socket contact	
HG-SR/ HG-JR53, 73, 103, 153, 203, 353, 503, 703, 903, 534, 734, 1034, 1534, 2034, 3534, 5034, 7034, 9034/ HG-RR/ HG-UR	IP67	Straight	One-touch connection type	CMV1-SP10S-M1	Select from solder or press bonding type. (Refer to the table below.)	5.5 to 7.5
				CMV1-SP10S-M2		7.0 to 9.0
			Screw type	CMV1S-SP10S-M1		5.5 to 7.5
				CMV1S-SP10S-M2		7.0 to 9.0
		Angle	One-touch connection type	CMV1-AP10S-M1		5.5 to 7.5
				CMV1-AP10S-M2		7.0 to 9.0
			Screw type	CMV1S-AP10S-M1		5.5 to 7.5
				CMV1S-AP10S-M2		7.0 to 9.0

Contact	Socket contact (DDK Ltd.)	Wire size <sup>(Note 3)</sup>
Solder type	CMV1-#22ASC-S1-100	0.5 mm <sup>2</sup> (AWG 20) or smaller
Press bonding type	CMV1-#22ASC-C1-100	0.2 mm <sup>2</sup> to 0.5 mm <sup>2</sup> (AWG 24 to 20) Crimping tool (357J-53162T) is required.
	CMV1-#22ASC-C2-100	0.08 mm <sup>2</sup> to 0.2 mm <sup>2</sup> (AWG 28 to 24) Crimping tool (357J-53163T) is required.

Notes: 1. The IP rating indicated is for the connector's protection against ingress of dust and water when coupled to a servo amplifier/servo motor. If the IP rating of the servo amplifier/servo motor differs from that of these connectors, overall IP rating depends on the lowest of all.

2. Contact Toa Electric Industrial Co., Ltd.

3. The wire size shows wiring specification of the connector.



**Products on the Market for Servo Motors**

Contact the relevant manufacturers directly. When fabricating a cable with the following connectors, refer to the relevant manufacturers' instruction manuals for wiring and assembling procedures.

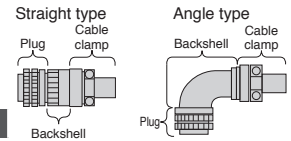

Encoder connector for HG-JR 1000 r/min series and 1500 r/min series (IP67 rated) **Rotary**

Applicable servo motor	IP rating (Note 1)	Plug (DDK Ltd.)		Backshell (DDK Ltd.)		Cable clamp (DDK Ltd.) Model	Applicable cable example	
		Model	Type	Model	Model		Wire size (Note 2)	Cable OD [mm]
HG-JR601, 801, 12K1, 15K1, 20K1, 25K1, 30K1, 37K1, 701M, 11K1M, 15K1M, 22K1M, 30K1M, 37K1M, 6014, 8014, 12K14, 15K14, 20K14, 25K14, 30K14, 37K14, 701M4, 11K1M4, 15K1M4, 22K1M4, 30K1M4, 37K1M4, 45K1M4, 55K1M4	IP67	D/MS3106A20-29S(D190)	Straight	CE02-20BS-S-D	CE3057-12A-3-D	0.3 mm <sup>2</sup> to 1.25 mm <sup>2</sup> (AWG 22 to 16)	6.8 to 10	
			Angle	CE-20BA-S-D				

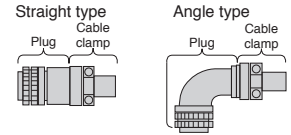

Encoder connector for HG-JR 1000 r/min series and 1500 r/min series **Rotary**

Applicable servo motor	IP rating (Note 1)	Plug (with backshell) (DDK Ltd.)		Cable clamp (DDK Ltd.) Model	Applicable cable example	
		Type	Model		Model	Wire size (Note 2)
HG-JR601, 801, 12K1, 15K1, 20K1, 25K1, 30K1, 37K1, 701M, 11K1M, 15K1M, 22K1M, 30K1M, 37K1M, 6014, 8014, 12K14, 15K14, 20K14, 25K14, 30K14, 37K14, 701M4, 11K1M4, 15K1M4, 22K1M4, 30K1M4, 37K1M4, 45K1M4, 55K1M4	-	Straight	D/MS3106B20-29S	D/MS3057-12A	0.3 mm <sup>2</sup> to 1.25 mm <sup>2</sup> (AWG 22 to 16)	15.9 or smaller (bushing ID)
			Angle			

Notes: 1. The IP rating indicated is for the connector's protection against ingress of dust and water when coupled to a servo amplifier/servo motor. If the IP rating of the servo amplifier/servo motor differs from that of these connectors, overall IP rating depends on the lowest of all.  
2. The wire size shows wiring specification of the connector.

## Options/Peripheral Equipment

### Products on the Market for Servo Motors

Contact the relevant manufacturers directly. When fabricating a cable with the following connectors, refer to the relevant manufacturers' instruction manuals for wiring and assembling procedures.

Encoder connector for TM-RG2M/TM-RU2M/TM-RFM series and absolute position storage unit connector (servo amplifier side) **Direct**



Applicable servo motor	Application	IP rating (Note 1)	Plug (Hirose Electric Co., Ltd.)			Applicable cable example
			Type	Plug	Cord clamp	
TM-RG2M/ TM-RU2M/ TM-RFM	For encoder or absolute position storage unit (servo amplifier side)	IP67	Straight	RM15WTPZK-12S	JR13WCCA-8(72)	Wire size: 0.5 mm <sup>2</sup> (AWG 20) or smaller Cable OD: 7.8 mm to 8.2 mm Wire example: Vinyl jacket cable 20276 VSVPAWG#23 X 6P KB-0492 Bando Densen Co., Ltd. (Note 3)

Encoder connector for TM-RG2M/TM-RU2M/TM-RFM series and absolute position storage unit connector (encoder side) **Direct**



Applicable servo motor	Application	IP rating (Note 1)	Plug (Hirose Electric Co., Ltd.)			Applicable cable example
			Type	Plug	Cord clamp	
TM-RG2M/ TM-RU2M/ TM-RFM	For absolute position storage unit (encoder side)	IP67	Straight	RM15WTPZ-12P(72)	JR13WCCA-8(72)	Wire size: 0.5 mm <sup>2</sup> (AWG 20) or smaller Cable OD: 7.8 mm to 8.2 mm Wire example: Vinyl jacket cable 20276 VSVPAWG#23 X 6P KB-0492 Bando Densen Co., Ltd. (Note 3)

Thermistor junction connector for LM-H3/LM-K2/LM-U2/LM-F series **Linear**



Applicable servo motor	IP rating (Note 1)	Connector (3M)		Applicable cable example
		Plug	Shell kit	
LM-H3/ LM-K2/ LM-U2/ LM-F	-	36110-3000FD	36310-F200-008	Wire size: 0.3 mm <sup>2</sup> (AWG 22) or smaller Cable OD: 7 mm to 9 mm

Thermistor connector for LM-F series **Linear**



Applicable servo motor	IP rating (Note 1)	Cable receptacle (DDK Ltd.)	Cable clamp (DDK Ltd.)	Applicable cable example
LM-F	-	D/MS3101A14S-9S	D/MS3057A-6A	Wire size: 0.3 mm <sup>2</sup> to 1.25 mm <sup>2</sup> (AWG 22 to 16) Cable OD: 7.9 mm or smaller

Power connector for HG-KR/HG-MR series **Rotary**



Applicable servo motor	IP rating (Note 1)	Connector (Japan Aviation Electronics Industry, Limited)	Crimping tool (Japan Aviation Electronics Industry, Limited)	Applicable cable example
HG-KR/ HG-MR	IP65	Plug: KN4FT04SJ1-R Socket contact: ST-TMH-S-C1B-100-(A534G)	For contactor: CT170-14-TMH5B	Wire size: 0.3 mm <sup>2</sup> to 0.75 mm <sup>2</sup> (AWG 22 to 18) Cable OD: 5.3 mm to 6.5 mm Wire example: Fluorine resin wire (Vinyl jacket cable RMFES-A (CL3X) AWG 19, 4 cores Dyden Corporation (Note 2) or an equivalent product)

Notes: 1. The IP rating indicated is for the connector's protection against ingress of dust and water when coupled to a servo amplifier/servo motor/absolute position storage unit. If the IP rating of the servo amplifier/servo motor/absolute position storage unit differs from that of these connectors, overall IP rating depends on the lowest of all.  
2. Contact Taisei Co., Ltd.  
3. Contact Toa Electric Industrial Co., Ltd.

**Rotary** Rotary servo motor    **Linear** Linear servo motor    **Direct** Direct drive motor

## Products on the Market for Servo Motors

Contact the relevant manufacturers directly. When fabricating a cable with the following connectors, refer to the relevant manufacturers' instruction manuals for wiring and assembling procedures.

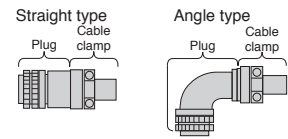

### Power connector for HG-SR/HG-JR/TM-RFM series **Rotary** **Direct**

Applicable servo motor	IP rating (Note 1)	Plug (with backshell) (DDK Ltd.)		Cable clamp (DDK Ltd.)	Applicable cable example		
		Type	Model		Model	Wire size (Note 2)	Cable OD [mm]
HG-SR51, 81, 52, 102, 152, 524, 1024, 1524/ HG-JR53, 73, 103, 153, 203, 534, 734, 1034, 1534, 2034, 3534, 5034/ TM-RFM012G20, 048G20, 072G20	IP67	Straight	CE05-6A18-10SD-D-BSS	CE3057-10A-2-D	2 mm <sup>2</sup> to 3.5 mm <sup>2</sup> (AWG 14 to 12)	8.5 to 11	
				CE3057-10A-1-D		10.5 to 14.1	
-	D/MS3106B18-10S		D/MS3057-10A	2 mm <sup>2</sup> to 3.5 mm <sup>2</sup> (AWG 14 to 12)	14.3 or smaller (bushing ID)		
HG-SR121, 201, 301, 202, 352, 502, 2024, 3524, 5024/ HG-JR353, 503/ TM-RFM040J10, 120J10	IP67		CE05-6A22-22SD-D-BSS	CE3057-12A-2-D	5.5 mm <sup>2</sup> to 8 mm <sup>2</sup> (AWG 10 to 8)	9.5 to 13	
				CE3057-12A-1-D		12.5 to 16	
-	D/MS3106B22-22S		D/MS3057-12A	5.5 mm <sup>2</sup> to 8 mm <sup>2</sup> (AWG 10 to 8)	15.9 or smaller (bushing ID)		
HG-SR421, 702, 7024/ HG-JR703, 903, 601, 801, 12K1, 701M, 11K1M, 15K1M, 7034, 9034, 6014, 8014, 12K14, 701M4, 11K1M4, 15K1M4/ TM-RFM240J10	IP67		CE05-6A32-17SD-D-BSS	CE3057-20A-1-D	14 mm <sup>2</sup> to 22 mm <sup>2</sup> (AWG 6 to 4)	22 to 23.8	
				-		D/MS3106B32-17S	D/MS3057-20A
HG-SR51, 81, 52, 102, 152, 524, 1024, 1524/ HG-JR53, 73, 103, 153, 203, 534, 734, 1034, 1534, 2034, 3534, 5034	IP67		Angle	CE05-8A18-10SD-D-BAS	CE3057-10A-2-D	2 mm <sup>2</sup> to 3.5 mm <sup>2</sup> (AWG 14 to 12)	8.5 to 11
					CE3057-10A-1-D		10.5 to 14.1
-	D/MS3108B18-10S	D/MS3057-10A		2 mm <sup>2</sup> to 3.5 mm <sup>2</sup> (AWG 14 to 12)	14.3 or smaller (bushing ID)		
HG-SR121, 201, 301, 202, 352, 502, 2024, 3524, 5024/ HG-JR353, 503	IP67	CE05-8A22-22SD-D-BAS		CE3057-12A-2-D	5.5 mm <sup>2</sup> to 8 mm <sup>2</sup> (AWG 10 to 8)	9.5 to 13	
				CE3057-12A-1-D		12.5 to 16	
-	D/MS3108B22-22S	D/MS3057-12A		5.5 mm <sup>2</sup> to 8 mm <sup>2</sup> (AWG 10 to 8)	15.9 or smaller (bushing ID)		
HG-SR421, 702, 7024/ HG-JR703, 903, 601, 801, 12K1, 701M, 11K1M, 15K1M, 7034, 9034, 6014, 8014, 12K14, 701M4, 11K1M4, 15K1M4	IP67	CE05-8A32-17SD-D-BAS		CE3057-20A-1-D	14 mm <sup>2</sup> to 22 mm <sup>2</sup> (AWG 6 to 4)	22 to 23.8	
				-		D/MS3108B32-17S	D/MS3057-20A

Notes: 1. The IP rating indicated is for the connector's protection against ingress of dust and water when coupled to a servo amplifier/servo motor. If the IP rating of the servo amplifier/servo motor differs from that of these connectors, overall IP rating depends on the lowest of all.

2. The wire size shows wiring specification of the connector. Refer to "Selection Example in HIV Wires for Servo Motors" in this catalog for examples of wire size selection.

**Rotary** Rotary servo motor    **Linear** Linear servo motor    **Direct** Direct drive motor

# Options/Peripheral Equipment

## Products on the Market for Servo Motors

Contact the relevant manufacturers directly. When fabricating a cable with the following connectors, refer to the relevant manufacturers' instruction manuals for wiring and assembling procedures.

Power connector for HG-JR 1000 r/min series (6 kW to 12 kW) and 1500 r/min series (7 kW to 15 kW) **Rotary**

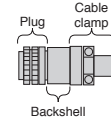

Applicable servo motor	IP rating (Note 1)	Plug (DDK Ltd.)		Backshell (DDK Ltd.)		Cable clamp (DDK Ltd.)	Applicable cable example	
		Model	Type	Model	Model	Wire size (Note 2)	Cable OD [mm]	
HG-JR601, 801, 12K1, 701M, 11K1M, 15K1M, 6014, 8014, 12K14, 701M4, 11K1M4, 15K1M4	IP67	CE05-6A32-17SD-D	Straight	CE05-32BS-S-D-OB (Note 4)	CE3057-24A-1-D	22 mm <sup>2</sup> (AWG 4)	30 to 32.5	
					CE3057-24A-2-D		27.5 to 29.6	

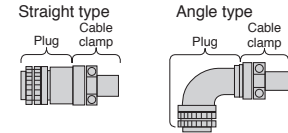

Power connector for HG-RR/HG-UR series **Rotary**

Applicable servo motor	IP rating (Note 1)	Plug (with backshell) (DDK Ltd.)		Cable clamp (DDK Ltd.)	Applicable cable example	
		Type	Model	Model	Wire size (Note 2)	Cable OD [mm]
HG-RR103, 153, 203/ HG-UR72, 152	IP67	Straight	CE05-6A22-23SD-D-BSS	CE3057-12A-2-D	2 mm <sup>2</sup> to 3.5 mm <sup>2</sup> (AWG 14 to 12)	9.5 to 13
				CE3057-12A-1-D		12.5 to 16
-	D/MS3106B22-23S		D/MS3057-12A	15.9 or smaller (bushing ID)		
	HG-RR353, 503/ HG-UR202, 352, 502		IP67	CE05-6A24-10SD-D-BSS	CE3057-16A-2-D	5.5 mm <sup>2</sup> to 8 mm <sup>2</sup> (AWG 10 to 8)
CE3057-16A-1-D		15 to 19.1				
-	D/MS3106B24-10S	D/MS3057-16A	19.1 or smaller (bushing ID)			
	HG-RR103, 153, 203/ HG-UR72, 152	IP67	Angle	CE05-8A22-23SD-D-BAS	CE3057-12A-2-D	2 mm <sup>2</sup> to 3.5 mm <sup>2</sup> (AWG 14 to 12)
CE3057-12A-1-D						
-	D/MS3108B22-23S	D/MS3057-12A		15.9 or smaller (bushing ID)		
	HG-RR353, 503/ HG-UR202, 352, 502	IP67		CE05-8A24-10SD-D-BAS	CE3057-16A-2-D	5.5 mm <sup>2</sup> to 8 mm <sup>2</sup> (AWG 10 to 8)
CE3057-16A-1-D			15 to 19.1			
-	D/MS3108B24-10S	D/MS3057-16A	19.1 or smaller (bushing ID)			

- Notes: 1. The IP rating indicated is for the connector's protection against ingress of dust and water when coupled to a servo amplifier/servo motor. If the IP rating of the servo amplifier/servo motor differs from that of these connectors, overall IP rating depends on the lowest of all.  
 2. The wire size shows wiring specification of the connector. Refer to "Selection Example in HIV Wires for Servo Motors" in this catalog for examples of wire size selection.  
 3. This connector is usable only when the outer diameter of the cable used for HG-JR 1000 r/min series (6 kW to 12 kW) and 1500 r/min series (7 kW to 15 kW) is larger than 23.8 mm.  
 4. This backshell is used to combine a plug (CE05-6A32-17SD-D) and a cable clamp (CE3057-24A-\_-D). Contact the manufacturers directly.

## Products on the Market for Servo Motors

Contact the relevant manufacturers directly. When fabricating a cable with the following connectors, refer to the relevant manufacturers' instruction manuals for wiring and assembling procedures.

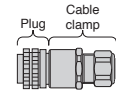

### Power connector for TM-RG2M/TM-RU2M/TM-RFM series **(Note 4)** **Direct**

Applicable servo motor	IP rating <sup>(Note 1)</sup>	Plug (DDK Ltd.)	Cable clamp			Applicable cable example	
			Type	Model	Manufacturer	Wire size <sup>(Note 2)</sup>	Cable OD [mm]
TM-RG2M_, TM-RU2M_, TM-RFM002C20, 004C20, 006C20, 006E20, 012E20, 018E20	IP67	CE05-6A14S-2SD-D	Straight	C2KD0814	Sankei Manufacturing Co., Ltd. <sup>(Note 3)</sup>	0.3 mm <sup>2</sup> to 1.25 mm <sup>2</sup> (AWG 22 to 16)	4 to 8
				C2KD1214			8 to 12
				YSO14-5 to 8	Daiwa Dengyo Co., Ltd.		5 to 8.3
				YSO14-9 to 11			8.3 to 11.3
-	D/MS3106B14S-2S	Straight	D/MS3057-6A	DDK Ltd.	0.3 mm <sup>2</sup> to 1.25 mm <sup>2</sup> (AWG 22 to 16)	7.9 or smaller (bushing ID)	

### Power connector for LM-F series **Linear**



Applicable servo motor	IP rating <sup>(Note 1)</sup>	Cable receptacle (DDK Ltd.)	Cable clamp (DDK Ltd.)	Applicable cable example	
				Wire size <sup>(Note 2)</sup>	Cable OD [mm]
LM-FP2B, 2D, 2F	-	D/MS3101A18-10S	D/MS3057-10A	2 mm <sup>2</sup> to 3.5 mm <sup>2</sup> (AWG 14 to 12)	14.3 or smaller (bushing ID)
LM-FP4B, 4D, 4F, 4H, 5H	-	D/MS3101A24-22S	D/MS3057-16A	5.5 mm <sup>2</sup> to 8 mm <sup>2</sup> (AWG 10 to 8)	19.1 or smaller (bushing ID)

- Notes: 1. The IP rating indicated is for the connector's protection against ingress of dust and water when coupled to a servo amplifier/servo motor. If the IP rating of the servo amplifier/servo motor differs from that of these connectors, overall IP rating depends on the lowest of all.
2. The wire size shows wiring specification of the connector. Refer to "Selection Example in HIV Wires for Servo Motors" in this catalog for examples of wire size selection.
3. Contact: Sankei Manufacturing Co., Ltd. and Mikuni Electric Co., Ltd.
4. When using TM-RG2M\_/TM-RU2M\_/TM-RFM\_C20/TM-RFM\_E20 for a machine that is required to comply with UL/CSA standards, do not use MR-PWCNF. Use a cable (SC-PWCFCBL\_M-L or SC-PWCFCBL\_M-H) manufactured by Mitsubishi Electric System & Service Co., Ltd. For details of SC-PWCFCBL\_M-L or SC-PWCFCBL\_M-H, please contact Mitsubishi Electric System & Service Co., Ltd. OVERSEAS SERVICE SECTION.  
(Email: osb.webmaster@melsc.jp)

# Options/Peripheral Equipment

## Products on the Market for Servo Motors

Contact the relevant manufacturers directly. When fabricating a cable with the following connectors, refer to the relevant manufacturers' instruction manuals for wiring and assembling procedures.

### Electromagnetic brake connector for HG-KR/HG-MR series **Rotary**



Applicable servo motor	IP rating (Note 1)	Connector (Japan Aviation Electronics Industry, Limited)	Crimping tool (Japan Aviation Electronics Industry, Limited)	Applicable cable example
HG-KR/ HG-MR	IP65	Plug: JN4FT02SJ1-R Socket contact: ST-TMH-S-C1B-100-(A534G)	For contactor: CT170-14-TMH5B	Wire size: 0.3 mm <sup>2</sup> to 0.5 mm <sup>2</sup> (AWG 22 to 20) Cable OD: 3.6 mm to 4.8 mm Wire example: Fluorine resin wire (Vinyl jacket cable RMFES-A (CL3X) AWG 20, 2 cores Dyden Corporation (Note 3) or an equivalent product)

### Electromagnetic brake connector for HG-SR/ HG-JR 3000 r/min series **Rotary**

Straight type      Angle type



Applicable servo motor	IP rating (Note 1)	Connector (DDK Ltd.)				Applicable cable example Cable OD [mm]
		Type	Type of connection	Plug	Socket contact	
HG-SR/ HG-JR53B, 73B, 103B, 153B, 203B, 353B, 503B, 703B, 903B, 534B, 734B, 1034B, 1534B, 2034B, 3534B, 5034B, 7034B, 9034B	IP67	Straight	One-touch connection type	CMV1-SP2S-S	Select from solder or press bonding type. (Refer to the table below.)	4.0 to 6.0
				CMV1-SP2S-M1		5.5 to 7.5
				CMV1-SP2S-M2		7.0 to 9.0
				CMV1-SP2S-L		9.0 to 11.6
			Screw type	CMV1S-SP2S-S		4.0 to 6.0
				CMV1S-SP2S-M1		5.5 to 7.5
				CMV1S-SP2S-M2		7.0 to 9.0
				CMV1S-SP2S-L		9.0 to 11.6
		Angle	One-touch connection type	CMV1-AP2S-S		4.0 to 6.0
				CMV1-AP2S-M1		5.5 to 7.5
				CMV1-AP2S-M2		7.0 to 9.0
				CMV1-AP2S-L		9.0 to 11.6
			Screw type	CMV1S-AP2S-S		4.0 to 6.0
				CMV1S-AP2S-M1		5.5 to 7.5
				CMV1S-AP2S-M2		7.0 to 9.0
				CMV1S-AP2S-L		9.0 to 11.6

Contact	Socket contact (DDK Ltd.)	Wire size (Note 2)
Solder type	CMV1-#22BSC-S2-100	1.25 mm <sup>2</sup> (AWG 16) or smaller
Press bonding type	CMV1-#22BSC-C3-100	0.5 mm <sup>2</sup> to 1.25 mm <sup>2</sup> (AWG 20 to 16) Crimping tool (357J-53164T) is required.

Notes: 1. The IP rating indicated is for the connector's protection against ingress of dust and water when coupled to a servo amplifier/servo motor. If the IP rating of the servo amplifier/servo motor differs from that of these connectors, overall IP rating depends on the lowest of all.

2. The wire size shows wiring specification of the connector. Refer to "Selection Example in HIV Wires for Servo Motors" in this catalog for examples of wire size selection.

3. Contact Taisei Co., Ltd.

## Products on the Market for Servo Motors

Contact the relevant manufacturers directly. When fabricating a cable with the following connectors, refer to the relevant manufacturers' instruction manuals for wiring and assembling procedures.

Electromagnetic brake connector for HG-JR 1000 r/min series (6 kW to 12 kW) and 1500 r/min series (7 kW to 15 kW)/HG-UR (2 kW or larger) series (IP67 rated) **Rotary**

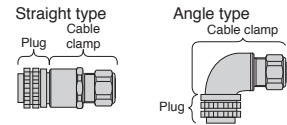

Applicable servo motor	IP rating (Note 1)	Plug (DDK Ltd.)		Cable clamp		Applicable cable example	
		Model	Type	Model	Manufacturer	Wire size (Note 2)	Cable OD [mm]
HG-JR601B, 801B, 12K1B, 701MB, 11K1MB, 15K1MB, 6014B, 8014B, 12K14B, 701M4B, 11K1M4B, 15K1M4B/HG-UR202B, 352B, 502B	IP67	D/MS3106A10SL-4S(D190)	Straight	C2KD0810	Sankei Manufacturing Co., Ltd. (Note 3)	0.3 mm <sup>2</sup> to 1.25 mm <sup>2</sup> (AWG 22 to 16)	4 to 8
				C2KD1210			8 to 12
				YSO10-5 to 8	Daiwa Dengyo Co., Ltd.		5 to 8.3
			Angle	C29KD0810	Sankei Manufacturing Co., Ltd. (Note 3)		4 to 8
				C29KD1210			8 to 12
				YLO10-5 to 8	Daiwa Dengyo Co., Ltd.		5 to 8.3

Electromagnetic brake connector for HG-JR 1000 r/min series (6 kW to 12 kW) and 1500 r/min series (7 kW to 15 kW)/HG-UR (2 kW or larger) series **Rotary**

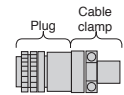

Applicable servo motor	IP rating (Note 1)	Plug (with backshell) (DDK Ltd.)		Cable clamp (DDK Ltd.)		Applicable cable example	
		Type	Model	Model	Wire size (Note 2)	Cable OD [mm]	
HG-JR601B, 801B, 12K1B, 701MB, 11K1MB, 15K1MB, 6014B, 8014B, 12K14B, 701M4B, 11K1M4B, 15K1M4B/HG-UR202B, 352B, 502B	-	Straight	D/MS3106A10SL-4S	D/MS3057-4A	0.3 mm <sup>2</sup> to 1.25 mm <sup>2</sup> (AWG 22 to 16)	5.6 or smaller (bushing ID)	

Cooling fan power connector for HG-JR 2000 r/min series **Rotary**

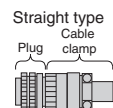

Applicable servo motor	IP rating (Note 1)	Plug (DDK Ltd.)		Cable clamp (Sankei Manufacturing Co., Ltd. (Note 3))		Applicable cable example	
		Model	Type	Model	Wire size (Note 2)	Cable OD [mm]	
HG-JR110K24W0C HG-JR150K24W0C HG-JR180K24W0C HG-JR200K24W0C HG-JR220K24W0C	IP67	CE05-6A10SL-3SC-D	Straight	C2KD0810	0.3 mm <sup>2</sup> to 1.25 mm <sup>2</sup> (AWG 22 to 16)	4 to 8	
				C2KD1210		8 to 12	

Notes: 1. The IP rating indicated is for the connector's protection against ingress of dust and water when coupled to a servo amplifier/servo motor. If the IP rating of the servo amplifier/servo motor differs from that of these connectors, overall IP rating depends on the lowest of all.

2. The wire size shows wiring specification of the connector. Refer to "Selection Example in HIV Wires for Servo Motors" in this catalog for examples of wire size selection.

3. Contact: Sankei Manufacturing Co., Ltd. and Mikuni Electric Co., Ltd.

**Rotary** Rotary servo motor

**Linear** Linear servo motor

**Direct** Direct drive motor

Configuration Example for MR-J4-GF-(-RJ)

GF GF-RJ

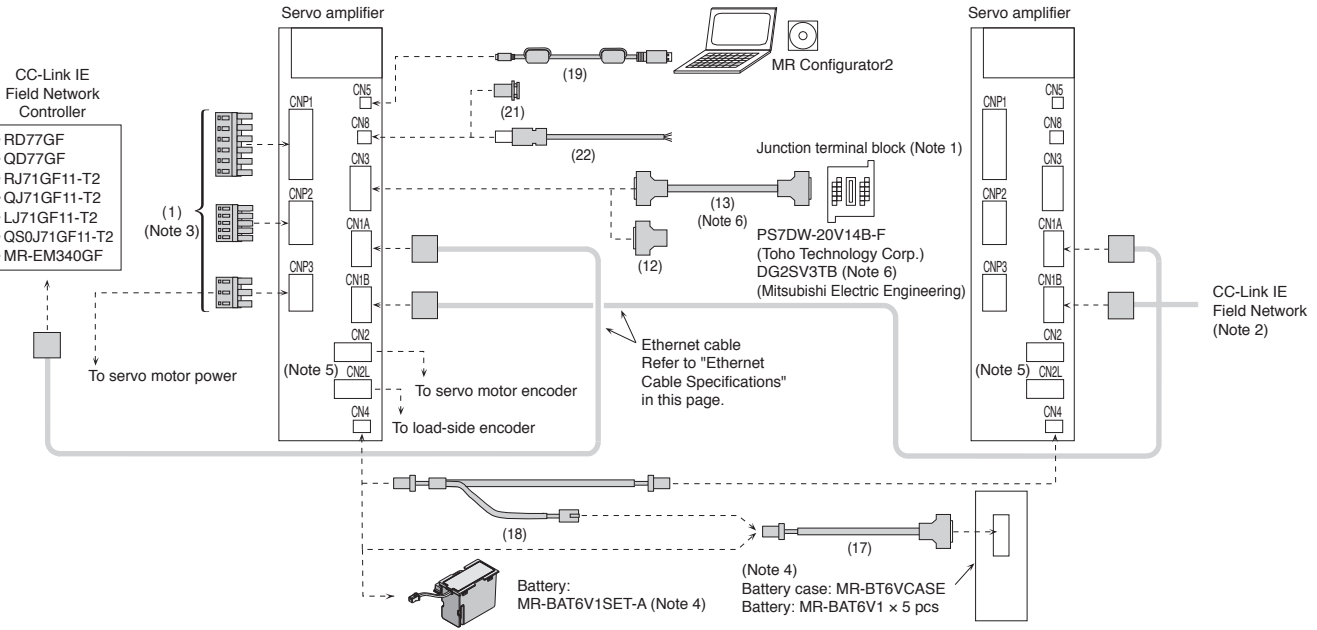

- Notes: 1. Refer to "Junction Terminal Block" in this catalog.  
 2. When branching off CC-Link IE Field Network (synchronous communication function) with a switching hub, use NZ2MHG-T8F2 (Mitsubishi Electric Corporation) or DT135TXA (Mitsubishi Electric System & Service Co., Ltd.).  
 3. The connectors are for 3.5 kW or smaller servo amplifiers. Terminal blocks are mounted for 5 kW or larger servo amplifiers.  
 4. Refer to "Battery" or "Battery Case and Battery" in this catalog. Battery and battery case are not required when the linear servo motor is used or when the servo amplifier is used in incremental system.  
 5. CN2L connector is available for MR-J4-GF-RJ servo amplifiers.  
 6. When using a junction terminal block and a cable manufactured by Mitsubishi Electric Engineering, refer to p. 5-52 in this catalog.

Ethernet Cable Specifications (Note 1, 2)

Item	Description	
Ethernet cable		Category 5e or higher, (double shielded/STP) straight cable
	Standard	The cable must meet the following: • IEEE802.3 (1000BASE-T) • ANSI/TIA/EIA-568-B (Category 5e)
	Connector	RJ-45 connector with shield

- Notes: 1. Use wiring parts recommended by CC-Link Partner Association for wiring the CC-Link IE Field Network.  
 2. CC-Link IE Field Network cables are not compatible with CC-Link IE Controller Network.

[Recommended products]

Switching hub

Mitsubishi Electric has confirmed the operation of the following CC-Link IE Field Network compatible switching hubs. Contact the manufacturers for details.

Item	Model	Synchronous communications (Motion mode)	Asynchronous communications (I/O mode)	Manufacturer
Industrial managed switch	NZ2MHG-T8F2	○ (Up to 4 levels)	○	Mitsubishi Electric Corporation
Industrial switching hub	DT135TXA	○ (Up to 4 levels)	○	Mitsubishi Electric System & Service Co., Ltd. (Note)
	NZ2EHG-T8N	—	○	Mitsubishi Electric Corporation

Ethernet Cable

Item	Model	Specifications
Ethernet Cable	For indoor	SC-E5EW-S_M _: cable length (0.5 m, 1 to 100 m (unit of 1 m))
	For indoor and moving part	SC-E5EW-S_M-MV _: cable length (0.1, 0.2, 0.3, 0.5 m, 1 to 45 m (unit of 1 m))
	For indoor/outdoor	SC-E5EW-S_M-L _: cable length (1 to 100 m (unit of 1 m))

For details, please contact Mitsubishi Electric System & Service Co., Ltd. OVERSEAS SERVICE SECTION. (Email: osb.webmaster@melsc.jp)

\* Refer to the website of CC-Link Partner Association for cables on the market other than above.  
<https://www.cc-link.org/en/>



Configuration Example for MR-J4-B (-RJ)/MR-J4-DU-B (-RJ) (Note 5)

**B** **B-RJ**

For MR-J4-B (-RJ)

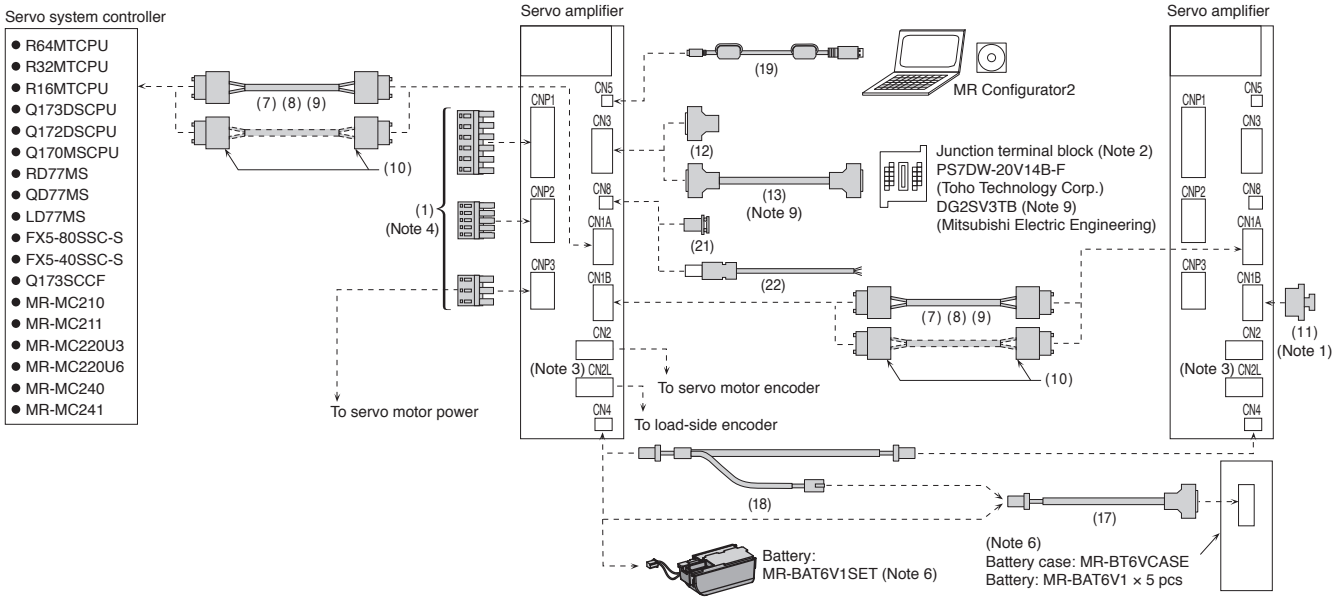

For Combination of MR-CV- and MR-J4-DU-B (-RJ)

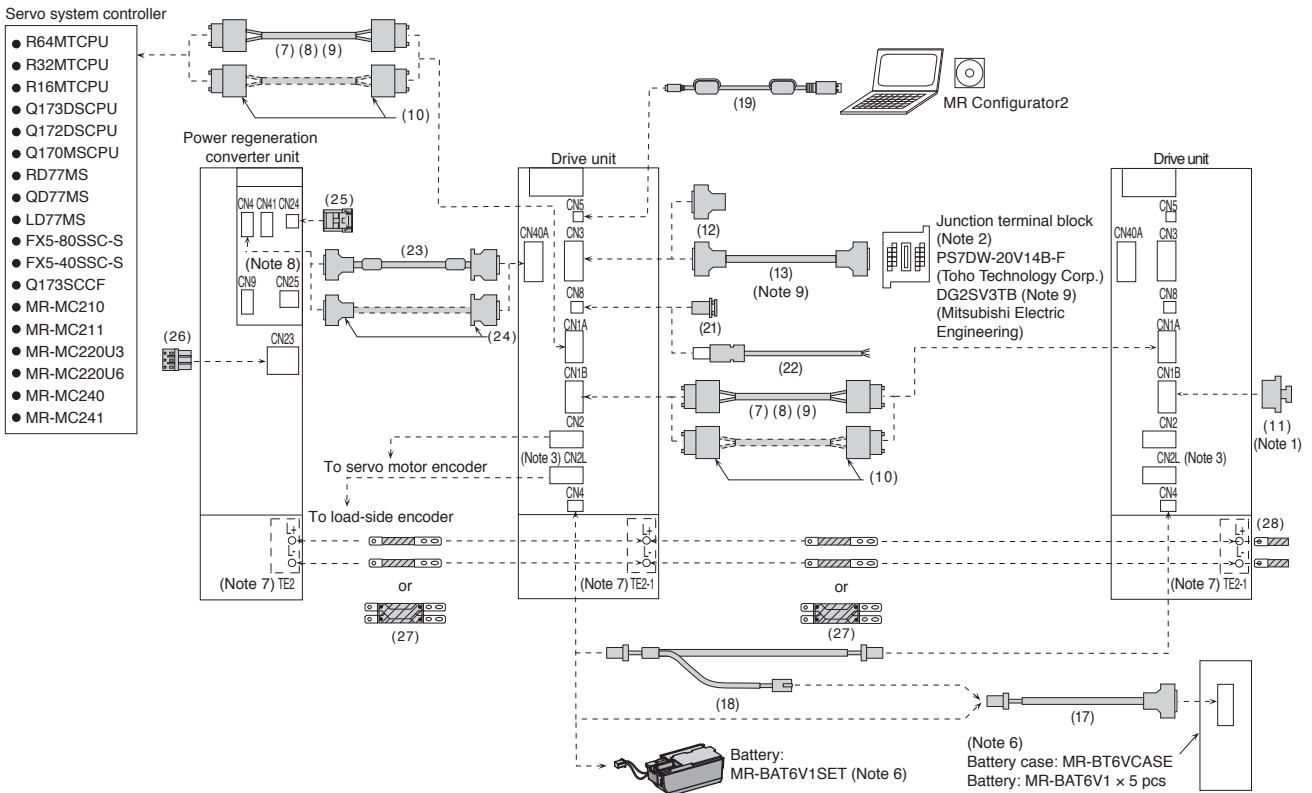

- Notes: 1. Be sure to attach a cap to CN1B connector of the final axis.  
 2. Refer to "Junction Terminal Block" in this catalog.  
 3. CN2L connector is available for MR-J4-B-RJ servo amplifiers and MR-J4-DU-B-RJ drive units.  
 4. The connectors are for 3.5 kW or smaller servo amplifiers. Terminal blocks are mounted for 5 kW or larger servo amplifiers.  
 5. Cables drawn with dashed lines need to be fabricated by user. Refer to relevant Servo Amplifier Instruction Manual for fabricating the cables.  
 6. Refer to "Battery" or "Battery Case and Battery" in this catalog. Battery and battery case are not required when the linear servo motor is used or when the servo amplifier is used in incremental system.  
 7. Terminal varies depending on the capacity of the power regeneration converter unit and the drive unit. Refer to "MR-J4-DU-B/MR-J4-DU-B-RJ Dimensions" and "MR-CV- Power Regeneration Converter Unit Dimensions" in this catalog.  
 8. Connect the wires directly to CN25 connector.  
 9. When using a junction terminal block and a cable manufactured by Mitsubishi Electric Engineering, refer to p. 5-52 in this catalog.

## Configuration Example for MR-J4-DU\_B4-RJ100 (Note 1)

B-RJ100

For MR-CV\_ and MR-J4-DU\_B4-RJ100

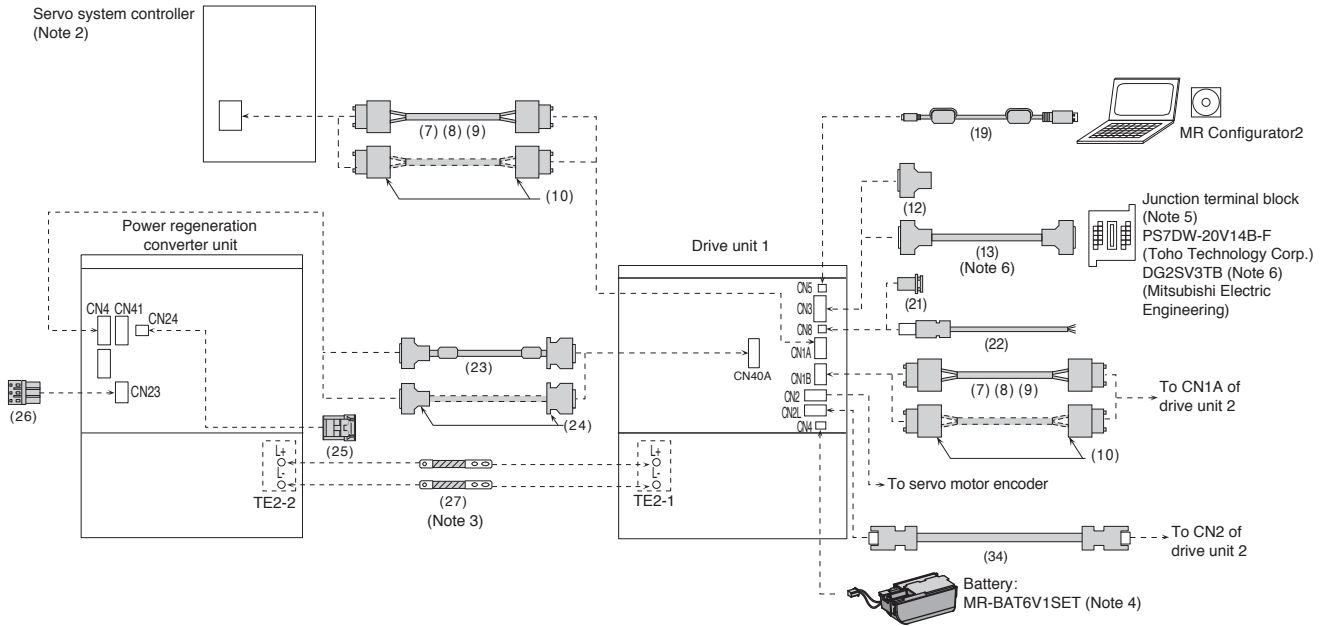

Notes: 1. Cables drawn with dashed lines need to be fabricated by user. Refer to relevant Servo Motor Instruction Manual for fabricating the cables.

2. Refer to "Compatible Controllers" on p. 1-50 in this catalog for compatible controllers. Contact your local sales office for more details.

3. The bus bar is supplied with the drive unit.

4. For absolute position detection system, connect an option battery only to the drive unit of the encoder primary servo amplifier. Do not connect the battery to the drive units of the encoder standby servo amplifiers.

5. Refer to "Junction Terminal Block" in this catalog.

6. When using a junction terminal block and a cable manufactured by Mitsubishi Electric Engineering, refer to p. 5-52 in this catalog.

Configuration Example for MR-J4-DU\_B\_(-RJ) (Note 4)

B B-RJ

For Combination of MR-CR\_ and MR-J4-DU\_B\_(-RJ) (Note 6)

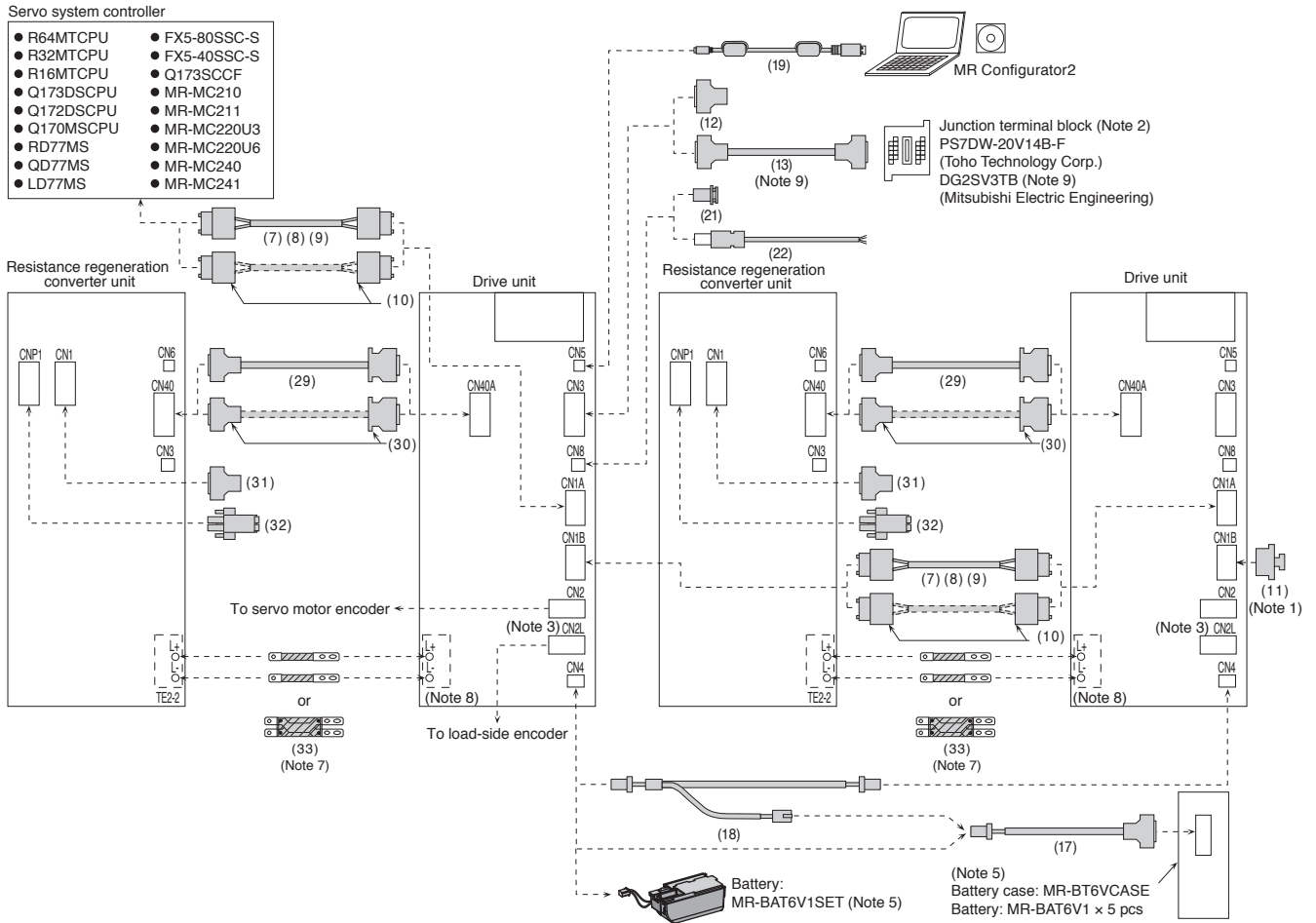

- Notes: 1. Be sure to attach a cap to CN1B connector of the final axis.  
 2. Refer to "Junction Terminal Block" in this catalog.  
 3. CN2L connector is available for MR-J4-DU\_B\_(-RJ) drive units.  
 4. Cables drawn with dashed lines need to be fabricated by user. Refer to relevant Servo Amplifier Instruction Manual for fabricating the cables.  
 5. Refer to "Battery" or "Battery Case and Battery" in this catalog. Battery and battery case are not required when the drive unit is used in incremental system.  
 6. The resistance regeneration converter units are supported only by 30 kW or larger drive units. Refer to "MR-CV\_ MR-CR55K\_ MR-J4-DU\_B\_(-RJ) MR-J4-DU\_A\_(-RJ) Instruction Manual" for details.  
 7. The bus bar is supplied with the drive unit.  
 8. Terminal varies depending on the capacity of the drive unit. Refer to "MR-J4-DU\_B/MR-J4-DU\_B-RJ Dimensions" in this catalog.  
 9. When using a junction terminal block and a cable manufactured by Mitsubishi Electric Engineering, refer to p. 5-52 in this catalog.

Servo Amplifiers  
 Rotary Servo Motors  
 Linear Servo Motors  
 Direct Drive Motors  
 Options/Peripheral Equipment  
 LVS/Wires  
 Product List  
 Precautions

## Configuration Example for MR-J4W2- B/MR-J4W3- B (Note 5)

WB

For MR-J4W2-22B to MR-J4W2-1010B/MR-J4W3-222B/MR-J4W3-444B

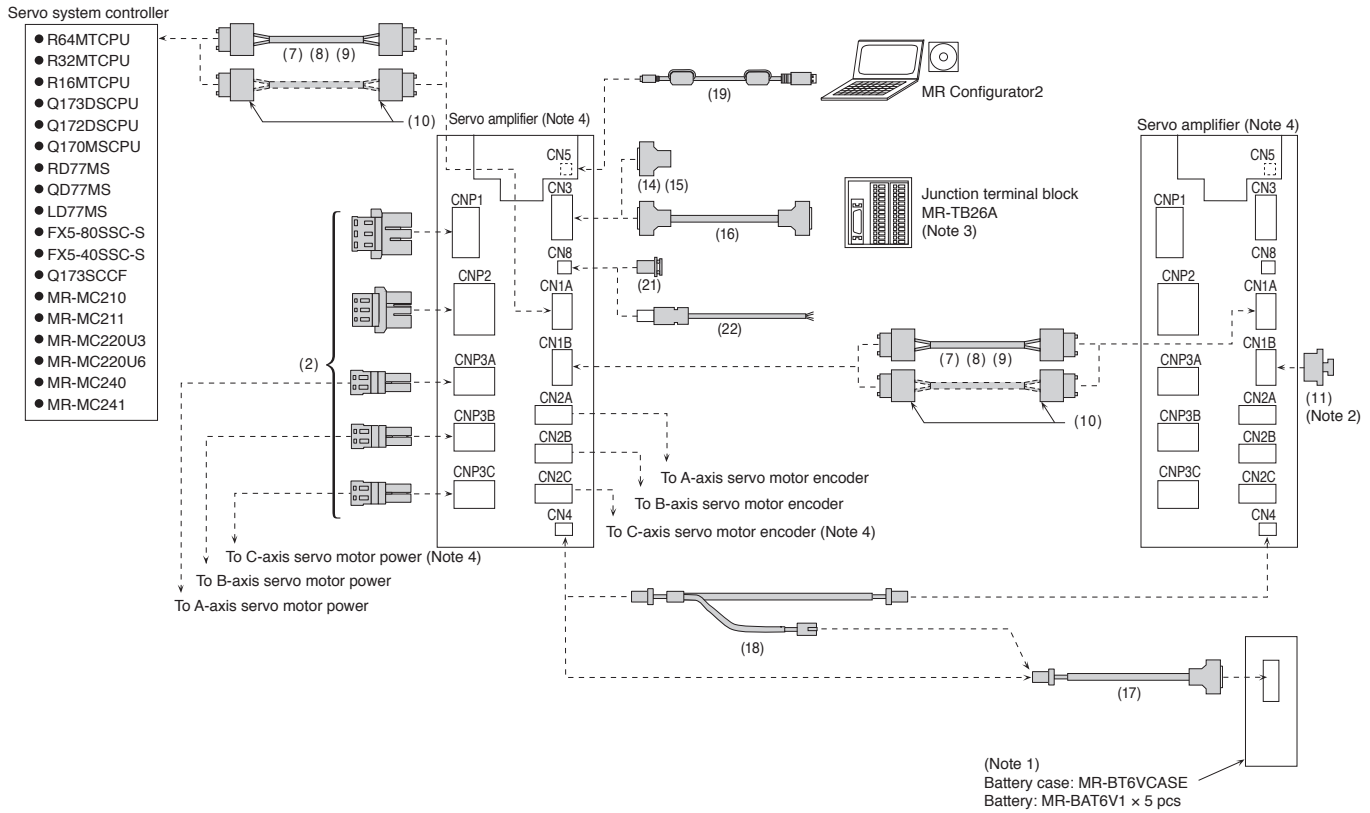

For MR-J4W2-0303B6

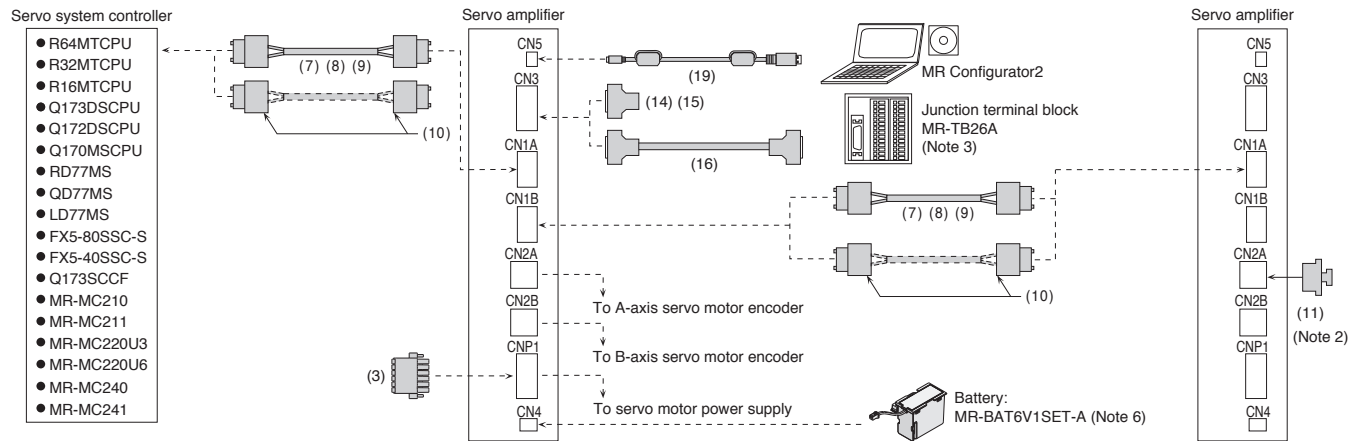

Notes: 1. Refer to "Battery Case and Battery" in this catalog. Battery and battery case are not required when the linear servo motor is used or when the servo amplifier is used in incremental system.

2. Be sure to attach a cap to CN1B connector of the final axis.

3. Refer to "Junction Terminal Block" in this catalog.

4. CNP3C and CN2C connectors are available for MR-J4W3-B servo amplifier.

5. Cables drawn with dashed lines need to be fabricated by user. Refer to relevant Servo Amplifier Instruction Manual for fabricating the cables.

6. Refer to "Battery" in this catalog. Battery is not required when the servo amplifier is used in incremental system.

Configuration Example for MR-J4- A (-RJ)/MR-J4-DU A (-RJ) (Note 6)

A A-RJ

For MR-J4- A (-RJ)

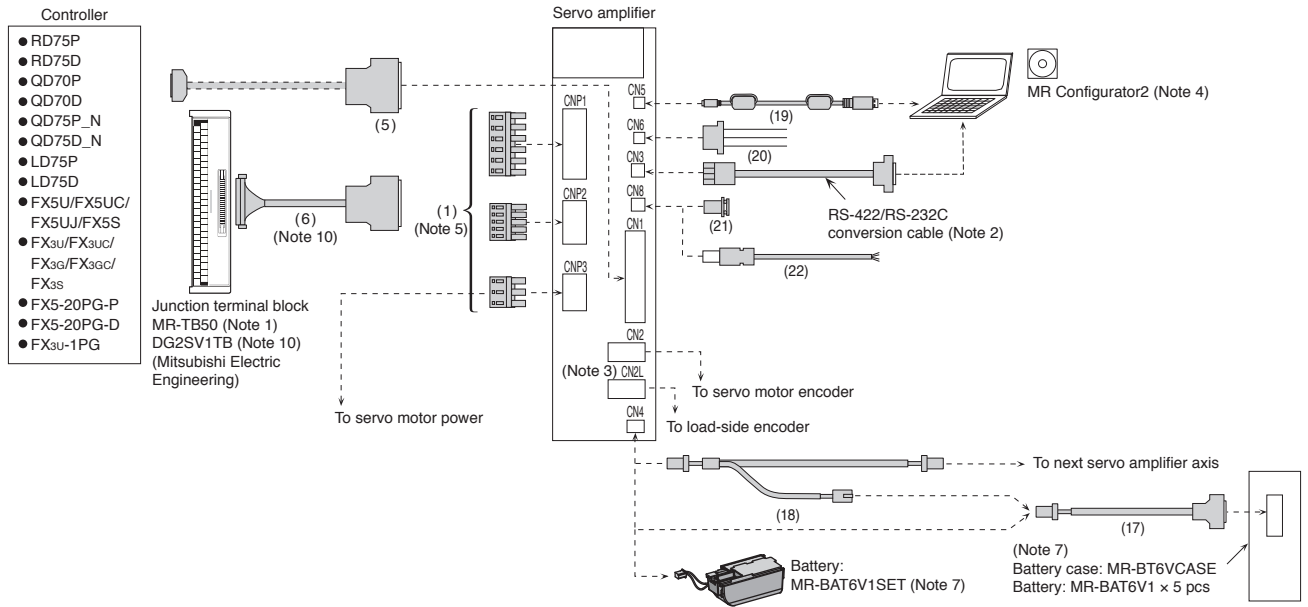

For Combination of MR-CR\_ and MR-J4-DU A (-RJ)

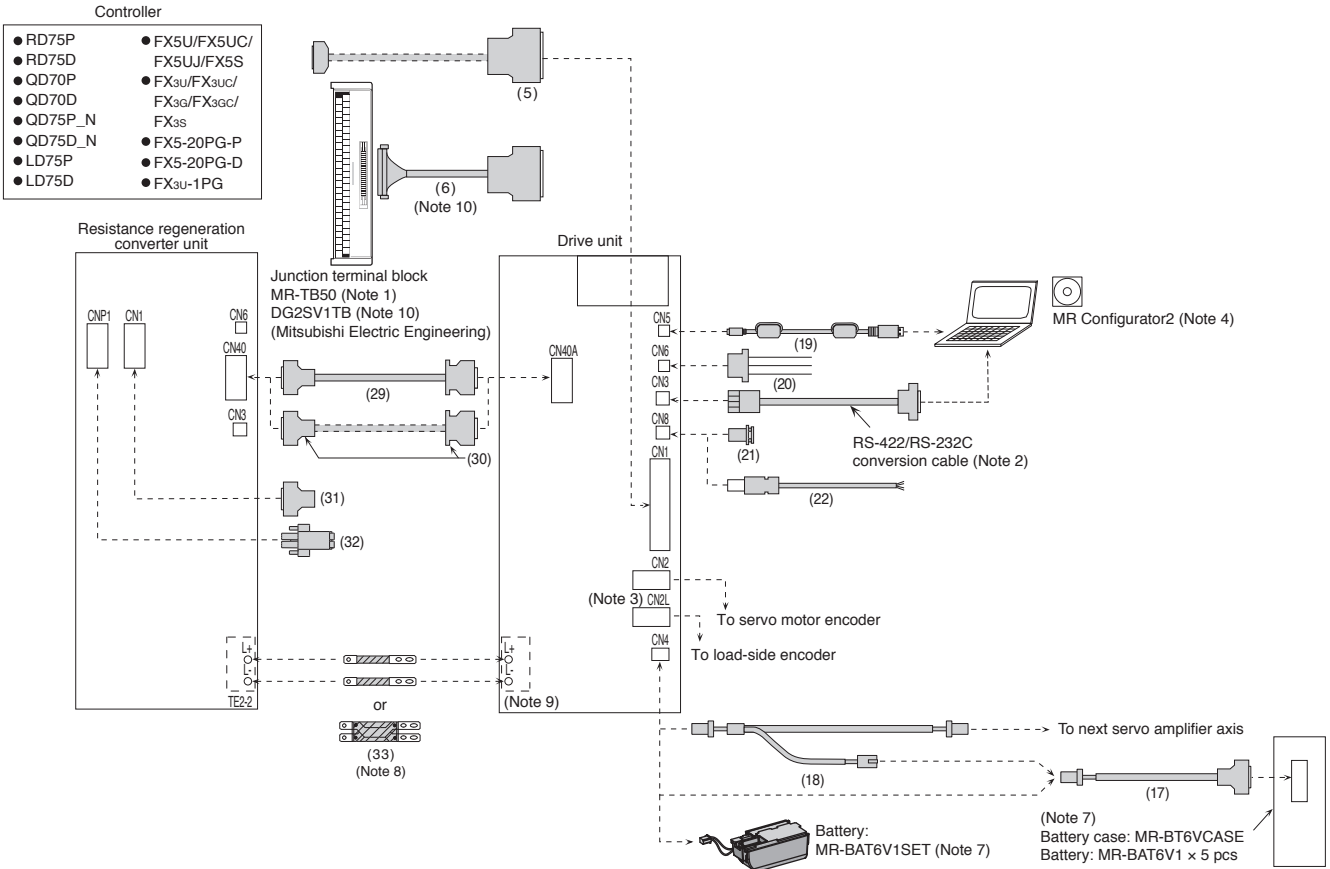

- Notes: 1. Refer to "Junction Terminal Block" in this catalog.  
 2. A conversion cable is required for using RS-422 serial communication function. Refer to "Products on the Market for Servo Amplifiers" in this catalog for the RS-422/RS-232C conversion cable.  
 3. CN2L connector is available for MR-J4- A -RJ servo amplifiers and MR-J4-DU A -RJ drive units.  
 4. MR Configurator2 supports only USB communication.  
 5. The connectors are for 3.5 kW or smaller servo amplifiers. Terminal blocks are mounted for 5 kW or larger servo amplifiers.  
 6. Cables drawn with dashed lines need to be fabricated by user. Refer to relevant Servo Amplifier Instruction Manual for fabricating the cables.  
 7. Refer to "Battery" or "Battery Case and Battery" in this catalog. Battery and battery case are not required when the linear servo motor is used or when the servo amplifier/drive unit is used in incremental system.  
 8. The bus bar is supplied with the drive unit.  
 9. Terminal varies depending on the capacity of the drive unit. Refer to "MR-J4-DU A/MR-J4-DU A-RJ Dimensions" in this catalog.  
 10. When using a junction terminal block and a cable manufactured by Mitsubishi Electric Engineering, refer to p. 5-54 in this catalog.

## Configuration Example of Cable and Connector for MR-J4-A(-RJ) (Note 3)

A A-RJ



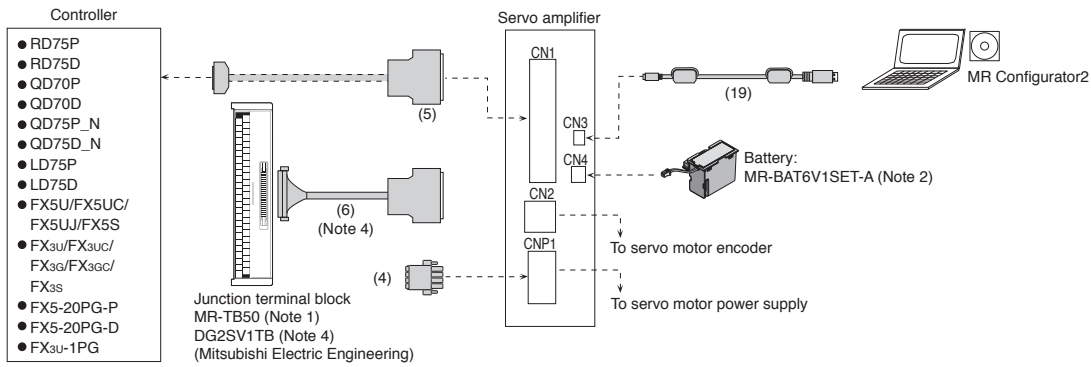















For MR-J4-03A6(-RJ)



- Notes: 1. Refer to "Junction Terminal Block" in this catalog.  
 2. Refer to "Battery" in this catalog. Battery is not required when the servo amplifier is used in incremental system.  
 3. Cables drawn with dashed lines need to be fabricated by user. Refer to relevant Servo Amplifier Instruction Manual for fabricating the cables.  
 4. When using a junction terminal block and a cable manufactured by Mitsubishi Electric Engineering, refer to p. 5-54 in this catalog.

Cables and Connectors for Servo Amplifiers

Refer to "Details of Option Connectors" in this catalog for the detailed models.

	Item	Model	Cable length	IP rating	Application	Description	
For CNP1/CNP2/CNP3	(1) Servo amplifier power connector set <small>(Note 1)</small>	(Standard accessory)	-	-	For MR-J4-100GF(-RJ) or smaller/ MR-J4-40GF1(-RJ) or smaller/ MR-J4-100B(-RJ) or smaller/ MR-J4-40B1(-RJ) or smaller/ MR-J4-100A(-RJ) or smaller/ MR-J4-40A1(-RJ) or smaller	    <p>Applicable wire size <small>(Note 2)</small>: AWG 18 to 14 Insulator OD: 3.9 mm or smaller</p>	
					For MR-J4-200GF(-RJ)/ MR-J4-200B(-RJ)/ MR-J4-200A(-RJ)/ MR-J4-350GF(-RJ)/ MR-J4-350B(-RJ)/ MR-J4-350A(-RJ)	    <p>CNP1/CNP3 connector Applicable wire size <small>(Note 2)</small>: AWG 16 to 10 Insulator OD: 4.7 mm or smaller CNP2 connector Applicable wire size <small>(Note 2)</small>: AWG 18 to 14 Insulator OD: 3.9 mm or smaller</p>	
					For MR-J4-350GF4(-RJ) or smaller/ MR-J4-350B4(-RJ) or smaller/ MR-J4-350A4(-RJ) or smaller	    <p>Applicable wire size <small>(Note 2)</small>: AWG 16 to 14 Insulator OD: 3.9 mm or smaller</p>	
For CNP1/CNP2/CNP3_	(2) Servo amplifier power connector set <small>(Note 3)</small>	(Standard accessory)	-	-		<p>CNP1 connector</p>  <p>Applicable wire size <small>(Note 2)</small>: AWG 16 to 14 Insulator OD: 4.2 mm or smaller</p> <p>CNP2 connector</p>  <p>Applicable wire size <small>(Note 2)</small>: AWG 16 to 14 Insulator OD: 3.8 mm or smaller</p> <p>CNP3A/CNP3B/CNP3C <small>(Note 4)</small> Open tool connector</p>   <p>Applicable wire size <small>(Note 2)</small>: AWG 18 to 14 Insulator OD: 3.8 mm or smaller</p>	
						For MR-J4W2-_B/ MR-J4W3-_B	
For CNP1	(3) Servo amplifier power connector	(Standard accessory)	-	-	For MR-J4W2-0303B6	<p>Power connector</p>  <p>Wire size: 0.2 mm<sup>2</sup> to 1.5 mm<sup>2</sup> (AWG 24 to 16) Insulator OD: 2.9 mm or smaller</p>	
	(4) Servo amplifier power connector	(Standard accessory)	-	-	For MR-J4-03A6(-RJ)	<p>Power connector</p>  <p>Wire size: 0.2 mm<sup>2</sup> to 1.5 mm<sup>2</sup> (AWG 24 to 16) Insulator OD: 2.9 mm or smaller</p>	



















Notes: 1. This connector set is not required for 5 kW or larger servo amplifiers because terminal blocks are mounted. Refer to servo amplifier dimensions in this catalog for details.  
 2. The wire size shows wiring specification of the connector. Refer to "Selection Example in HIV Wires for Servo Motors" in this catalog for examples of wire size selection.  
 3. Press bonding type is also available. Refer to "MR-J4W2-\_B MR-J4W3-\_B MR-J4W2-0303B6 Servo Amplifier Instruction Manual" for details.  
 4. MR-J4W2-\_B: CNP3A/CNP3B, MR-J4W3-\_B: CNP3A/CNP3B/CNP3C

Servo Amplifiers  
 Rotary Servo Motors  
 Linear Servo Motors  
 Direct Drive Motors  
 Options/Peripheral Equipment  
 LV5/Wires  
 Product List  
 Precautions

# Options/Peripheral Equipment

## Cables and Connectors for Servo Amplifiers

Refer to "Details of Option Connectors" in this catalog for the detailed models.

	Item	Model	Cable length	IP rating	Application	Description
For CN1	(5) Connector set	MR-J3CN1	-	-	For MR-J4-_A_(-RJ)/ MR-J4-03A6(-RJ) MR-J4-DU_A_(-RJ)	 Servo amplifier connector
	(6) Junction terminal block cable	MR-J2M-CN1TBL05M	0.5 m	-	For connecting MR-J4-_A_(-RJ)/ MR-J4-03A6(-RJ) MR-J4-DU_A_(-RJ), MR-TB50	Junction terminal block connector  Servo amplifier connector 
MR-J2M-CN1TBL1M		1 m				
For controller/CN1A/CN1B	(7) SSCNET III cable (Note 1) (standard cord inside cabinet) Compatible with SSCNET III(/H)	MR-J3BUS015M	0.15 m	-	For MR-J4-_B_(-RJ)/ MR-J4-DU_B_(-RJ)/ MR-J4W2-_B(6)/ MR-J4W3-_B	SSCNET III(/H) connector  SSCNET III(/H) connector 
		MR-J3BUS03M	0.3 m	-		
		MR-J3BUS05M	0.5 m	-		
		MR-J3BUS1M	1 m	-		
	(8) SSCNET III cable (Note 1) (standard cable outside cabinet) Compatible with SSCNET III(/H)	MR-J3BUS5M-A <sup>*1</sup>	5 m	-	For MR-J4-_B_(-RJ)/ MR-J4-DU_B_(-RJ)/ MR-J4W2-_B(6)/ MR-J4W3-_B	 
		MR-J3BUS10M-A <sup>*1</sup>	10 m	-		
		MR-J3BUS20M-A <sup>*1</sup>	20 m	-		
	(9) SSCNET III cable (Note 1, 3) (long distance cable, long bending life) Compatible with SSCNET III(/H)	MR-J3BUS30M-B <sup>*1</sup>	30 m	-	For MR-J4-_B_(-RJ)/ MR-J4-DU_B_(-RJ)/ MR-J4W2-_B(6)/ MR-J4W3-_B	 
		MR-J3BUS40M-B <sup>*1</sup>	40 m	-		
		MR-J3BUS50M-B <sup>*1</sup>	50 m	-		
(10) SSCNET III connector set (Note 1, 2) Compatible with SSCNET III(/H)	MR-J3BCN1	-	-	For MR-J4-_B_(-RJ)/ MR-J4-DU_B_(-RJ)/ MR-J4W2-_B(6)/ MR-J4W3-_B	SSCNET III(/H) connector  SSCNET III(/H) connector 	
For CN1B	(11) SSCNET III connector cap Compatible with SSCNET III(/H)	(Standard accessory)	-	-	For MR-J4-_B_(-RJ)/ MR-J4-DU_B_(-RJ)/ MR-J4W2-_B(6)/ MR-J4W3-_B	
For CN3	(12) Connector set	MR-CCN1	-	-	For MR-J4-_GF_(-RJ)/ MR-J4-_B_(-RJ)/ MR-J4-DU_B_(-RJ)	 Servo amplifier connector
	(13) Junction terminal block cable	MR-J2HBUS05M	0.5 m	-	For connecting MR-J4-_GF_(-RJ)/ MR-J4-_B_(-RJ)/ MR-J4-DU_B_(-RJ)/ PS7DW-20V14B-F	Servo amplifier connector  Junction terminal block connector 
		MR-J2HBUS1M	1 m			
		MR-J2HBUS5M	5 m			
	(14) Connector set (Qty: 1 pc)	MR-J2CMP2	-	-	For MR-J4W2-_B(6)/ MR-J4W3-_B	 Servo amplifier connector
	(15) Connector set (Qty: 20 pcs)	MR-ECN1	-	-	For MR-J4W2-_B(6)/ MR-J4W3-_B	
(16) Junction terminal block cable	MR-TBNATBL05M	0.5 m	-	For connecting MR-J4W2-_B(6)/ MR-J4W3-_B, MR-TB26A	Servo amplifier connector  Junction terminal block connector 	
	MR-TBNATBL1M	1 m				

Notes: 1. Read carefully through the precautions enclosed with the options before use.

2. Dedicated tools are required. Contact your local sales office for more details.

3. When SSCNET III/H is used, refer to "Products on the Market for Servo Amplifiers" in this catalog for cables over 50 m or with ultra-long bending life.



For unlisted lengths

\*1. For unlisted lengths of the cables, please contact Mitsubishi Electric System & Service Co., Ltd. OVERSEAS SERVICE SECTION (Email: osb.webmaster@melsc.jp)

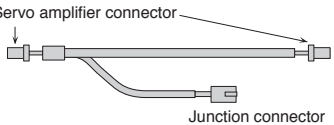
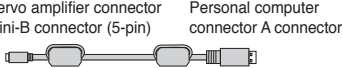

## Cables and Connectors for Servo Amplifiers

Refer to "Details of Option Connectors" in this catalog for the detailed models.

	Item	Model	Cable length	IP rating	Application	Description
For CN4	(17) Battery cable	MR-BT6V1CBL03M	0.3 m	-	For connecting MR-J4-_GF_(-RJ)/ MR-J4-_B_(-RJ)/ MR-J4-DU_B_(-RJ)/ MR-J4-_A_(-RJ)/ MR-J4-DU_A_(-RJ)/ MR-J4W2-_B/ MR-J4W3-_B, MR-BT6VCASE	
		MR-BT6V1CBL1M	1 m			
	(18) Junction battery cable	MR-BT6V2CBL03M	0.3 m	-	For MR-J4-_GF_(-RJ)/ MR-J4-_B_(-RJ)/ MR-J4-DU_B_(-RJ)/ MR-J4-_A_(-RJ)/ MR-J4-DU_A_(-RJ)/ MR-J4W2-_B/ MR-J4W3-_B	
		MR-BT6V2CBL1M	1 m			
For CNS	(19) Personal computer communication cable (USB cable)	MR-J3USBCBL3M	3 m	-	For MR-J4-_GF_(-RJ)/ MR-J4-_B_(-RJ)/ MR-J4-DU_B_(-RJ)/ MR-J4-_A_(-RJ)/ MR-J4-03A6(-RJ)/ MR-J4-DU_A_(-RJ)/ MR-J4W2-_B(6)/ MR-J4W3-_B	 <p>* Do not use this cable for SSCNET III(H) compatible controller.</p>
For CN6	(20) Monitor cable	MR-J3CN6CBL1M	1 m	-	For MR-J4-_A_(-RJ)/ MR-J4-DU_A_(-RJ)	
For CN8	(21) Short-circuit connector	(Standard accessory)	-	-	For MR-J4-_GF_(-RJ)/ MR-J4-_B_(-RJ)/ MR-J4-DU_B_(-RJ)/ MR-J4-_A_(-RJ)/ MR-J4-DU_A_(-RJ)/ MR-J4W2-_B/ MR-J4W3-_B	 <p>This connector is required when the STO function is not used.</p>
		(22) STO cable	MR-D05UDL3M-B	3 m	-	For connecting MR-J3-D05 or other safety control device with MR-J4-_GF_(-RJ)/ MR-J4-_B_(-RJ)/ MR-J4-DU_B_(-RJ)/ MR-J4-_A_(-RJ)/ MR-J4-DU_A_(-RJ)/ MR-J4W2-_B/ MR-J4W3-_B

Servo Amplifiers

Rotary Servo Motors

Linear Servo Motors

Direct Drive Motors

Options/Peripheral Equipment

LV5/Wires











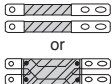
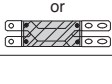

Product List

Precautions

# Options/Peripheral Equipment

## Cables and Connectors for Servo Amplifiers

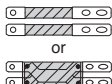
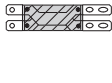
Refer to "Details of Option Connectors" in this catalog for the detailed models.

	Item	Model	Cable length	IP rating	Application	Description
For CN4 on power regeneration converter unit and CN44 on drive unit	(23) Protection coordination cable	MR-CUL06M	0.6 m	-	For MR-J4-DU_B_(-RJ)/MR-CV_	Power regeneration converter unit connector  Drive unit connector
	(24) Connector set	MR-J2CN1-A	-	-	For MR-J4-DU_B_(-RJ)/MR-CV_	Power regeneration converter unit connector  Drive unit connector
For CN24 on power regeneration converter unit	(25) Connector set (Note 1)	MR-CVCN24S	-	-	-	Power regeneration converter unit connector 
For CN23 on power regeneration converter unit	(26) Magnetic contactor wiring connector	(Standard accessory)	-	-	For MR-CV_	Power regeneration converter unit connector  Open tool 
For power regeneration converter unit and drive unit	(27) Bus bar (Note 2)	-	-	-	-	 or  Refer to "Bus Bar" in this catalog for details.
	(28) Adjustment bar (Note 3)	MR-DCBAR035-B05	-	-	-	
For CN40 on resistance regeneration converter unit and CN40A on drive unit	(29) Protection coordination cable	MR-J3CDL05M	0.5 m	-	For MR-J4-DU30KB_ or larger/ MR-J4-DU30KA_ or larger/ MR-CR55K_	Resistance regeneration converter unit connector  Drive unit connector
		MR-CUL06M	0.6 m	-		Resistance regeneration converter unit connector  Drive unit connector
For CN1 on resistance regeneration converter unit	(30) Connector set	MR-J2CN1-A	-	-	For MR-J4-DU30KB_ or larger/ MR-J4-DU30KA_ or larger/ MR-CR55K_	Resistance regeneration converter unit connector  Drive unit connector
	(31) Digital input/output connector	(Standard accessory)	-	-	For MR-CR55K_	Resistance regeneration converter unit connector 
For CN1 on resistance regeneration converter unit	(32) Magnetic contactor wiring connector	(Standard accessory)	-	-	For MR-CR55K_	Resistance regeneration converter unit connector 
For resistance regeneration converter unit and drive unit	(33) Bus bar	(Standard accessory)	-	-	For MR-J4-DU30KB or larger/ MR-J4-DU30KA or larger/ MR-J4-DU45KB4 or larger/ MR-J4-DU45KA4 or larger/ MR-CR55K_	 or 
		(Standard accessory)	-	-	For MR-J4-DU30KB4/ MR-J4-DU37KB4/ MR-J4-DU30KA4/ MR-J4-DU37KA4/ MR-CR55K4	
For drive unit	(34) Encoder cable between drive units (Note 4)	MR-J4CN2CBL1M-H	1 m	-	For MR-J4-DU45KB4-RJ100, MR-J4-DU55KB4-RJ100	Drive unit connector  Drive unit connector
		MR-J4CN2CBL2M-H	2 m			
		MR-J4CN2CBL3M-H	3 m			
		MR-J4CN2CBL5M-H	5 m			

Notes: 1. A crimping tool (357J-22733) manufactured by DDK Ltd. is required. Contact the manufacturer directly.

2. The bus bar varies depending on the combination of the power regeneration converter unit and the drive unit. Refer to "Bus Bar" in this catalog for details.

3. The adjustment bar is required when the total number of MR-J4-DU900B(4)(-RJ) and MR-J4-DU11KB(4)(-RJ) drive units connected to the power regeneration converter unit is even because there is a gap between the bus bar and TE2 terminal block of the final drive unit axis (right end). Place the adjustment bars in the gap and tighten the screws.

4. Use these dedicated encoder cables between drive units. Using cables other than dedicated cables may lead to device failure.

## Bus Bar (for 200 V)

B B-RJ

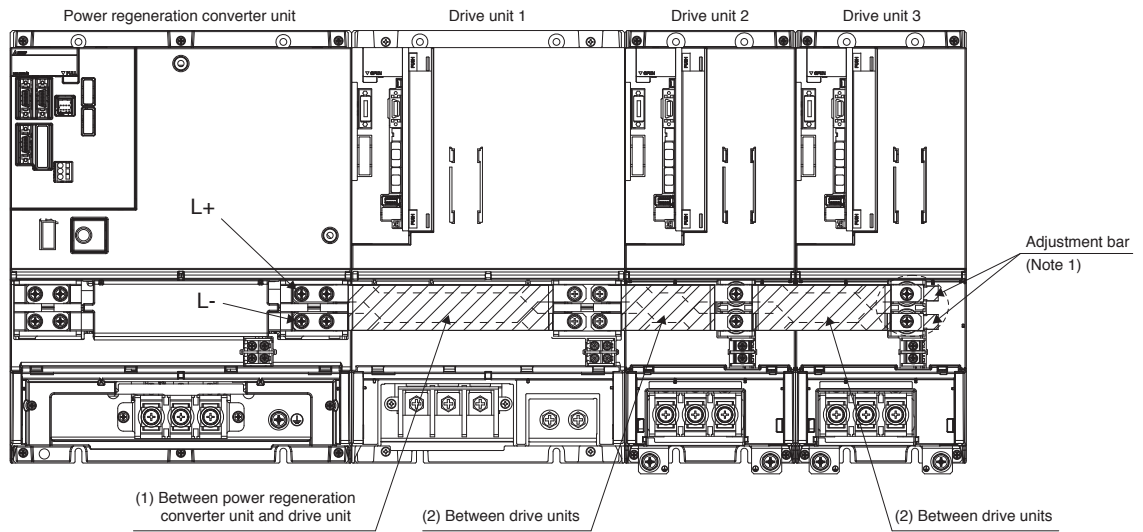

Notes: 1. When an even number of drive units MR-J4-DU900B(4)(-RJ) and MR-J4-DU11KB(4)(-RJ) is connected to the power regeneration converter unit, a space is formed between the bus bars and the TE2 terminal block of the final drive unit. To fill this space, place adjustment bars between the bus bars and the TE2 terminal block, and tighten the screws.

## (1) Between power regeneration converter unit and drive unit

Unit mounted on the left side (Note 1)	Unit mounted on the right side (Note 1, 3)	Bus bar model
MR-CV11K	MR-J4-DU900B, MR-J4-DU11KB	MR-DCBAR137-B52
MR-CV18K	MR-J4-DU900B, MR-J4-DU11KB MR-J4-DU15KB	MR-DCBAR137-B52 MR-DCBAR235-B52
MR-CV30K	MR-J4-DU900B, MR-J4-DU11KB MR-J4-DU15KB, MR-J4-DU22KB MR-J4-DU30KB	MR-DCBAR159-B52 MR-DCBAR255-B52 MR-DCBAR105-C03
MR-CV37K, MR-CV45K	MR-J4-DU900B, MR-J4-DU11KB MR-J4-DU15KB, MR-J4-DU22KB MR-J4-DU30KB, MR-J4-DU37KB	MR-DCBAR159-B52 MR-DCBAR255-B52 MR-DCBAR105-C03
MR-CV55K	MR-J4-DU900B, MR-J4-DU11KB MR-J4-DU15KB, MR-J4-DU22KB MR-J4-DU30KB, MR-J4-DU37KB	MR-DCBAR159-B53 MR-DCBAR257-B53 MR-DCBAR106-C04 (Note 2)

## (2) Between drive units

Unit mounted on the left side (Note 1, 3)	Unit mounted on the right side (Note 1, 3)	Bus bar model
MR-J4-DU900B	MR-J4-DU900B	MR-DCBAR170-B52
MR-J4-DU11KB	MR-J4-DU900B, MR-J4-DU11KB	MR-DCBAR170-B52
MR-J4-DU15KB	MR-J4-DU900B, MR-J4-DU11KB MR-J4-DU15KB	MR-DCBAR137-B52 MR-DCBAR235-B52
MR-J4-DU22KB	MR-J4-DU900B, MR-J4-DU11KB MR-J4-DU15KB, MR-J4-DU22KB	MR-DCBAR137-B52 MR-DCBAR235-B52
MR-J4-DU30KB	MR-J4-DU900B, MR-J4-DU11KB MR-J4-DU15KB, MR-J4-DU22KB MR-J4-DU30KB	MR-DCBAR159-B53 MR-DCBAR257-B53 MR-DCBAR106-C04 (Note 2)
MR-J4-DU37KB	MR-J4-DU900B, MR-J4-DU11KB MR-J4-DU15KB, MR-J4-DU22KB MR-J4-DU30KB, MR-J4-DU37KB	MR-DCBAR159-B53 MR-DCBAR257-B53 MR-DCBAR106-C04 (Note 2)

Notes: 1. "Unit mounted on the left side" and "Unit mounted on the right side" indicate the position when the units are seen from the front. Be sure to install the power regeneration converter unit on the left side of the drive unit.

2. This bus bar is supplied with the drive unit.

3. Note that the drive units with special specification (MR-J4-DU\_B-RJ/-EB/-KS) also use the same bus bars listed.

## Options/Peripheral Equipment

### Bus Bar (for 400 V)

**B** **B-RJ** **B-RJ100**

#### (1) Power regeneration converter unit and drive unit

Unit mounted on the left side <sup>(Note 1)</sup>	Unit mounted on the right side <sup>(Note 1, 3)</sup>	Bus bar model
MR-CV11K4	MR-J4-DU900B4, MR-J4-DU11KB4	MR-DCBAR137-B52
MR-CV18K4	MR-J4-DU900B4, MR-J4-DU11KB4	MR-DCBAR137-B52
	MR-J4-DU15KB4	MR-DCBAR235-B52
MR-CV30K4	MR-J4-DU900B4, MR-J4-DU11KB4	MR-DCBAR159-B52
	MR-J4-DU15KB4, MR-J4-DU22KB4	MR-DCBAR255-B52
	MR-J4-DU30KB4	MR-DCBAR082-C02
MR-CV37K4	MR-J4-DU900B4, MR-J4-DU11KB4	MR-DCBAR159-B52
	MR-J4-DU15KB4, MR-J4-DU22KB4	MR-DCBAR255-B52
	MR-J4-DU30KB4, MR-J4-DU37KB4	MR-DCBAR082-C02
MR-CV45K4	MR-J4-DU900B4, MR-J4-DU11KB4	MR-DCBAR159-B52
	MR-J4-DU15KB4, MR-J4-DU22KB4	MR-DCBAR255-B52
	MR-J4-DU30KB4, MR-J4-DU37KB4	MR-DCBAR082-C02
	MR-J4-DU45KB4	MR-DCBAR105-C03
MR-CV55K4, MR-CV75K4	MR-J4-DU900B4, MR-J4-DU11KB4	MR-DCBAR159-B53
	MR-J4-DU15KB4, MR-J4-DU22KB4	MR-DCBAR257-B53
	MR-J4-DU30KB4, MR-J4-DU37KB4	MR-DCBAR085-C03 <sup>(Note 2)</sup>
	MR-J4-DU45KB4, MR-J4-DU55KB4	MR-DCBAR106-C04 <sup>(Note 2)</sup>

#### (2) Between drive units

Unit mounted on the left side <sup>(Note 1, 3)</sup>	Unit mounted on the right side <sup>(Note 1, 3)</sup>	Bus bar model
MR-J4-DU900B4	MR-J4-DU900B4	MR-DCBAR170-B52
MR-J4-DU11KB4	MR-J4-DU900B4, MR-J4-DU11KB4	MR-DCBAR170-B52
MR-J4-DU15KB4	MR-J4-DU900B4, MR-J4-DU11KB4	MR-DCBAR137-B52
	MR-J4-DU15KB4	MR-DCBAR235-B52
MR-J4-DU22KB4	MR-J4-DU900B4, MR-J4-DU11KB4	MR-DCBAR137-B52
	MR-J4-DU15KB4, MR-J4-DU22KB4	MR-DCBAR235-B52
MR-J4-DU30KB4	MR-J4-DU900B4, MR-J4-DU11KB4	MR-DCBAR310-B52
	MR-J4-DU15KB4, MR-J4-DU22KB4	MR-DCBAR409-B52
	MR-J4-DU30KB4	MR-DCBAR235-B52
MR-J4-DU37KB4	MR-J4-DU900B4, MR-J4-DU11KB4	MR-DCBAR310-B52
	MR-J4-DU15KB4, MR-J4-DU22KB4	MR-DCBAR409-B52
	MR-J4-DU30KB4, MR-J4-DU37KB4	MR-DCBAR235-B52
MR-J4-DU45KB4	MR-J4-DU900B4, MR-J4-DU11KB4	MR-DCBAR159-B53
	MR-J4-DU15KB4, MR-J4-DU22KB4	MR-DCBAR257-B53
	MR-J4-DU30KB4, MR-J4-DU37KB4	MR-DCBAR085-C03 <sup>(Note 2)</sup>
	MR-J4-DU45KB4	MR-DCBAR106-C04 <sup>(Note 2)</sup>
MR-J4-DU55KB4	MR-J4-DU900B4, MR-J4-DU11KB4	MR-DCBAR159-B53
	MR-J4-DU15KB4, MR-J4-DU22KB4	MR-DCBAR257-B53
	MR-J4-DU30KB4, MR-J4-DU37KB4	MR-DCBAR085-C03 <sup>(Note 2)</sup>
	MR-J4-DU45KB4, MR-J4-DU55KB4	MR-DCBAR106-C04 <sup>(Note 2)</sup>

Notes: 1. "Unit mounted on the left side" and "Unit mounted on the right side" indicate the position when the units are seen from the front. Be sure to install the power regeneration converter unit on the left side of the drive unit.

2. This bus bar is supplied with the drive unit.

3. Note that the drive units with special specification (MR-J4-DU\_B-RJ/RJ100/EB/KS) also use the same bus bars listed.

Configuration Example for MR-D30

GF-RJ B-RJ B-RJ100 A-RJ

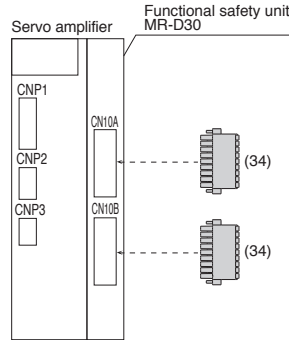

Cables and Connectors for MR-D30

Refer to "Details of Option Connector for MR-D30" in this catalog for the detailed models.

	Item	Model	Cable length	IP rating	Application	Description
For CN10A/CN10B	(34) Connector (Qty: 2 pcs)	(Standard accessory of MR-D30)	-	-	For MR-D30	 Functional safety connector

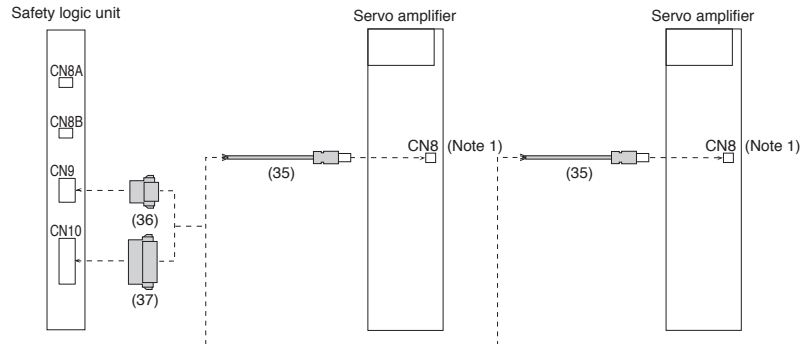

Configuration Example for MR-J3-D05

GF GF-RJ B B-RJ WB A A-RJ



Cables and Connectors for MR-J3-D05

Refer to "Details of Option Connectors for MR-J3-D05" in this catalog for the detailed models.

	Item	Model	Cable length	IP rating	Application	Description
For CN8	(35) STO cable	MR-D05UDL3M-B	3 m	-	For connecting MR-J3-D05 or other safety control device with MR-J4- <u>GF</u> (-RJ)/ MR-J4- <u>B</u> (-RJ)/ MR-J4- <u>DU_B</u> (-RJ)/ MR-J4- <u>A</u> (-RJ)/ MR-J4- <u>DU_A</u> (-RJ)/ MR-J4W2- <u>B</u> / MR-J4W3- <u>B</u>	 Servo amplifier connector
For CN9	(36) Connector	(Standard accessory of MR-J3-D05)	-	-	For MR-J3-D05	 Safety logic unit connector
For CN10	(37) Connector	(Standard accessory of MR-J3-D05)	-	-	For MR-J3-D05	 Safety logic unit connector

Notes: 1. Be sure to attach a short-circuit connector supplied with the servo amplifier when the STO function is not used.

Configuration Example for MR-D01

A-RJ

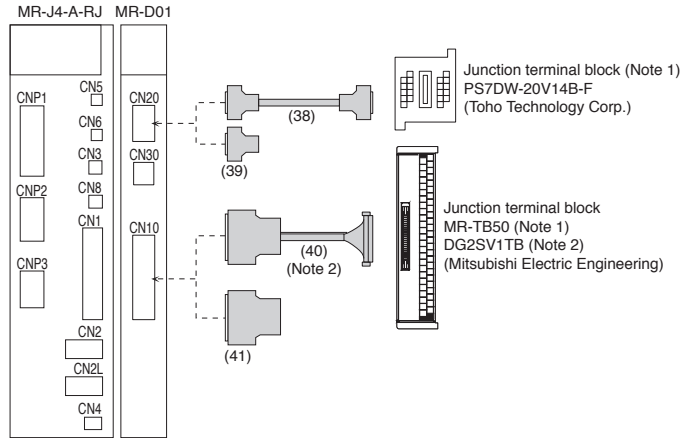





















Cables and Connectors for MR-D01

Refer to "Details of Option Connectors for Servo Amplifiers/MR-D01" in this catalog for the detailed models.

	Item	Model	Cable length	IP rating	Application	Description
For CN20	(38) Junction terminal block cable	MR-J2HBUS05M	0.5 m	-	For MR-D01	MR-D01 connector      Junction terminal block connector
		MR-J2HBUS1M	1 m			
		MR-J2HBUS5M	5 m			
(39) Connector set	MR-CCN1	-	-		MR-D01 connector	
For CN10	(40) Junction terminal block cable	MR-J2M-CN1TBL05M	0.5 m	-	For MR-D01	MR-D01 connector      Junction terminal block connector
		MR-J2M-CN1TBL1M	1 m			
	(41) Connector set	MR-J3CN1	-	-		

Notes: 1. Refer to "Junction Terminal Block" in this catalog.  
 2. When using a junction terminal block and a cable manufactured by Mitsubishi Electric Engineering, refer to p. 5-54 in this catalog.

## Details of Option Connectors for Servo Amplifiers/MR-D01

Model	CNP1 connector	CNP2 connector	CNP3 connector	Open tool
Servo amplifier power connector set For MR-J4-100GF(-RJ) or smaller/ MR-J4-40GF1(-RJ) or smaller/ MR-J4-100B(-RJ) or smaller/ MR-J4-40B1(-RJ) or smaller/ MR-J4-100A(-RJ) or smaller/ MR-J4-40A1(-RJ) or smaller (Standard accessory)	 06JFAT-SAXGDK-H7.5 (J.S.T. Mfg. Co., Ltd.)	 05JFAT-SAXGDK-H5.0 (J.S.T. Mfg. Co., Ltd.)	 03JFAT-SAXGDK-H7.5 (J.S.T. Mfg. Co., Ltd.)	 J-FAT-OT (N) (J.S.T. Mfg. Co., Ltd.)
Servo amplifier power connector set For MR-J4-200GF(-RJ)/ MR-J4-200B(-RJ)/ MR-J4-200A(-RJ)/ MR-J4-350GF(-RJ)/ MR-J4-350B(-RJ)/ MR-J4-350A(-RJ) (Standard accessory)	 06JFAT-SAXGFK-XL (J.S.T. Mfg. Co., Ltd.)	 05JFAT-SAXGDK-H5.0 (J.S.T. Mfg. Co., Ltd.)	 03JFAT-SAXGFK-XL (J.S.T. Mfg. Co., Ltd.)	 J-FAT-OT-EXL (J.S.T. Mfg. Co., Ltd.)
Servo amplifier power connector set For MR-J4-350GF4(-RJ) or smaller/ MR-J4-350B4(-RJ) or smaller/ MR-J4-350A4(-RJ) or smaller (Standard accessory)	 06JFAT-SAXGDK-HT10.5 (J.S.T. Mfg. Co., Ltd.)	 05JFAT-SAXGDK-HT7.5 (J.S.T. Mfg. Co., Ltd.)	 03JFAT-SAXGDK-HT10.5 (J.S.T. Mfg. Co., Ltd.)	 J-FAT-OT-XL (J.S.T. Mfg. Co., Ltd.)
Model	Servo amplifier power connector			
Servo amplifier power connector For MR-J4W2-0303B6 (Standard accessory)			Connector: DFMC 1,5/ 6-ST-3,5-LR (Phoenix Contact) or an equivalent product	
Model	Servo amplifier power connector			
Servo amplifier power connector For MR-J4-03A6(-RJ) (Standard accessory)			Connector: DFMC 1,5/ 4-ST-3,5-LR (Phoenix Contact) or an equivalent product	
Model	CNP1 connector	CNP2 connector	CNP3A/B/C connector	Open tool
Servo amplifier power connector set For MR-J4W2-_B/MR-J4W3-_B (Standard accessory)	 03JFAT-SAXGFK-43 (J.S.T. Mfg. Co., Ltd.)	 06JFAT-SAXYGG-F-KK (J.S.T. Mfg. Co., Ltd.)	 04JFAT-SAGG-G-KK (J.S.T. Mfg. Co., Ltd.)	 J-FAT-OT-EXL (J.S.T. Mfg. Co., Ltd.)
Model	Servo amplifier/MR-D01 connector			
MR-J3CN1			Connector: 10150-3000PE Shell kit: 10350-52F0-008 (3M) or an equivalent product	
Model	Junction terminal block connector	Servo amplifier/MR-D01 connector		
MR-J2M-CN1TBL_M	 Connector: D7950-B500FL (3M)	 Press bonding type <sup>(Note 1)</sup> Connector: 10150-6000EL Shell kit: 10350-3210-000 (3M)		

Notes: 1. Solder type (connector: 10150-3000PE and shell kit: 10350-52F0-008) (3M) is also usable. Contact the manufacturer directly.

Servo Amplifiers

Rotary Servo Motors

Linear Servo Motors

Direct Drive Motors

Options/Peripheral Equipment













LV5/Wires

Product List

Precautions

# Options/Peripheral Equipment



## Details of Option Connectors for Servo Amplifiers/MR-D01

Model	SSCNET III(/H) connector	SSCNET III(/H) connector
MR-J3BUS_M MR-J3BUS_M-A MR-J3BCN1	 Connector: PF-2D103 (Japan Aviation Electronics Industry, Limited)	 Connector: PF-2D103 (Japan Aviation Electronics Industry, Limited)
Model	SSCNET III(/H) connector	SSCNET III(/H) connector
MR-J3BUS_M-B	 Connector: CF-2D103-S (Japan Aviation Electronics Industry, Limited)	 Connector: CF-2D103-S (Japan Aviation Electronics Industry, Limited)
Model	Servo amplifier/MR-D01 connector	
MR-CCN1		Solder type <sup>(Note 1)</sup> Connector: 10120-3000PE Shell kit: 10320-52F0-008 (3M) or an equivalent product
Model	Servo amplifier/MR-D01 connector	Junction terminal block connector
MR-J2HBUS_M	 Press bonding type <sup>(Note 2)</sup> Connector: 10120-6000EL Shell kit: 10320-3210-000 (3M) or an equivalent product	 Press bonding type <sup>(Note 2)</sup> Connector: 10120-6000EL Shell kit: 10320-3210-000 (3M) or an equivalent product
Model	Servo amplifier connector	
MR-J2CMP2 MR-ECN1		Connector: 10126-3000PE Shell kit: 10326-52F0-008 (3M) or an equivalent product
Model	Servo amplifier connector	Junction terminal block connector
MR-TBNATBL_M	 Connector: 10126-6000EL Shell kit: 10326-3210-000 (3M) or an equivalent product	 Connector: 10126-6000EL Shell kit: 10326-3210-000 (3M) or an equivalent product
Model	Servo amplifier connector	Battery case connector
MR-BT6V1CBL_M	 Contact: SPHD-001G-P0.5 Housing: PAP-02V-O (J.S.T. Mfg. Co., Ltd.)	 Solder type <sup>(Note 3)</sup> Connector: 10114-3000PE Shell kit: 10314-52F0-008 (3M) or an equivalent product

- Notes: 1. Press bonding type (connector: 10120-6000EL and shell kit: 10320-3210-000) (3M) is also usable. Contact the manufacturer directly.  
 2. Solder type (connector: 10120-3000PE and shell kit: 10320-52F0-008) (3M) is also usable. Contact the manufacturer directly.  
 3. Press bonding type (connector: 10114-6000EL and shell kit: 10314-3210-000) (3M) is also usable. Contact the manufacturer directly.





## Details of Option Connectors for Servo Amplifiers



Model	Servo amplifier connector	Junction connector
MR-BT6V2CBL_M	 Contact: SPHD-001G-P0.5 Housing: PAP-02V-O (J.S.T. Mfg. Co., Ltd.)	 Contact: SPAL-001GU-P0.5 Housing: PALR-02VF-O (J.S.T. Mfg. Co., Ltd.)



Model	Servo amplifier connector
MR-J3CN6CBL1M	 Housing: 51004-0300 Terminal: 50011-8100 (Molex, LLC)

## Details of Option Connectors for Drive Unit/Power Regeneration Converter Unit

Model	Power regeneration converter unit connector	Drive unit connector
MR-CUL06M MR-J2CN1-A	 Connector: 10120-3000PE Shell kit: 10320-52F0-008 (3M) or an equivalent product	 Connector: PCR-S20FS+ Case: PCR-LS20LA1 (Honda Tsushin Kogyo Co., Ltd.)

Model	Power regeneration converter unit connector
MR-CVCN24S	 Connector: DK-2100D-08R Contact: DK-2RECSLP1-100 (DDK Ltd.)

Model	Power regeneration converter unit connector	Open tool
Magnetic contactor wiring connector (Standard accessory of power regeneration converter unit)	 Connector: 03JFAT-SAXGSA-L (J.S.T. Mfg. Co., Ltd.)	 J-FAT-OT-EXL (J.S.T. Mfg. Co., Ltd.)

Model	Drive unit connector	Drive unit connector
MR-J4CN2CBL_M-H	 Receptacle: 36210-0100PL Shell kit: 36310-3200-008 (3M) or Connector set: 54599-1019 (Molex, LLC)	 Receptacle: 36210-0100PL Shell kit: 36310-3200-008 (3M) or Connector set: 54599-1019 (Molex, LLC)

Servo Amplifiers

Rotary Servo Motors

Linear Servo Motors

Direct Drive Motors

Options/Peripheral Equipment



LVs/Wires

Product List

Precautions

## Options/Peripheral Equipment

### Details of Option Connectors for Drive Unit/Resistance Regeneration Converter Unit

Model	Resistance regeneration converter unit connector	Drive unit connector
MR-J3CDL05M MR-J2CN1-A	 Connector: 10120-3000PE Shell kit: 10320-52F0-008 (3M) or an equivalent product	 Connector: PCR-S20FS+ Case: PCR-LS20LA1 (Honda Tsushin Kogyo Co., Ltd.)

Model	Resistance regeneration converter unit connector
Digital input/output connector (Standard accessory of resistance regeneration converter unit)	 Connector: 17JE23090-02(D8A)K11-CG (DDK Ltd.)

Model	Resistance regeneration converter unit connector
Magnetic contactor wiring connector (Standard accessory of resistance regeneration converter unit)	 Socket: GFKC 2,5/ 2-STF-7,62 (Phoenix Contact)

### Details of Option Connector for MR-D30

Model	Functional safety unit connector
Connector for CN10A/CN10B of functional safety unit (Standard accessory of MR-D30)	 Connector: DFMC 1,5/ 9-STF-3,5 (Phoenix Contact)

### Details of Option Connectors for MR-J3-D05

Model	Servo amplifier connector
MR-D05UDL3M-B	 Connector set: 2069250-1 (TE Connectivity Ltd. Company)

Model	Safety logic unit connector
Connector for CN9 of safety logic unit (Standard accessory of MR-J3-D05)	 Connector: 1-1871940-4 (TE Connectivity Ltd. Company)

Model	Safety logic unit connector
Connector for CN10 of safety logic unit (Standard accessory of MR-J3-D05)	 Connector: 1-1871940-8 (TE Connectivity Ltd. Company)

## Products on the Market for Servo Amplifiers

Contact the relevant manufacturers directly. When fabricating a cable with the following connectors, refer to the relevant manufacturers' instruction manuals for wiring and assembling procedures.

### Personal computer communication cable

**A A-RJ**

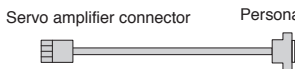
Application	Model	Description
RS-422/RS-232C conversion cable	DSV-CABV	 Servo amplifier connector      Personal computer connector Diatrend Corp.

### RS-422 connector

**A A-RJ**

Application	Model	Description
RS-422 connector	TM10P-88P	 Hirose Electric Co., Ltd.

### RS-422 branch connector (for multi-drop)

**A A-RJ**

Application	Model	Description
Branch connector	BMJ-8	 Hachiko Electric Co., Ltd.

### SSCNET III cable

**B B-RJ B-RJ100 WB**

Application	Model	Description
Standard cable outside cabinet for SSCNET III(/H)	SC-J4BUS_M-A	_ = cable length (100 m <sup>(Note 1)</sup> maximum, unit of 1 m)
Long distance cable, ultra-long bending life cable for SSCNET III(/H)	SC-J3BUS_M-C	
		 Mitsubishi Electric System & Service Co., Ltd.

### Products on the Market for MR-J4W2-\_B/MR-J4W3-\_B

**WB**

Contact Mitsubishi Electric System & Service Co., Ltd. for power cables with a press bonding type connector for MR-J4W2-\_B/MR-J4W3-\_B servo amplifiers and power cables for servo motors.

### Cable for MODBUS® RTU <sup>(Note 2)</sup>

**A-RJ**

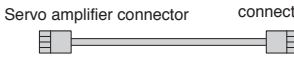
Application	Model	Cable length	Description
RJ-45 compatible cable designed for MR-J4-A-RJ	DSV-CABMD06	0.6 m	 Servo amplifier connector      RJ-45 compatible junction connector terminal block Diatrend Corp.

### RJ-45 compatible junction connector terminal block for MODBUS® RTU <sup>(Note 2)</sup>

**A-RJ**

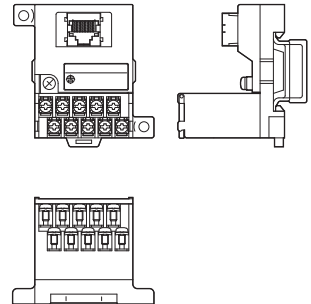
Application	Model	Description
RJ-45 compatible junction connector terminal block	PX7D-10V4-RJ45 (spring-up screw)	 Toho Technology Corp., Kyoto Factory PS7D-10V4-RJ45 (self-up screw) is also usable.

Notes: 1. The maximum wiring distance between stations is 100 m for SSCNET III/H and 50 m for SSCNET III.

2. This cannot be used with MR-J4-03A6(-RJ).

## Application of connecting encoder junction cable

GF GF-RJ B B-RJ WB A A-RJ

Unlisted lengths of cables between servo amplifier and servo motor, EMC cables, and special cables for connecting servo amplifier and servo motor with multiple cables are available. Please contact Mitsubishi Electric System & Service Co., Ltd. OVERSEAS SERVICE SECTION (Email: osb.webmaster@melsec.jp)

Example) Configuration using three encoder junction cables

- Replacing only the cable of the moving part in the cable chain is possible.
- Resetting after transporting a machine is easy because the servo amplifier side and the servo motor side can be separated.

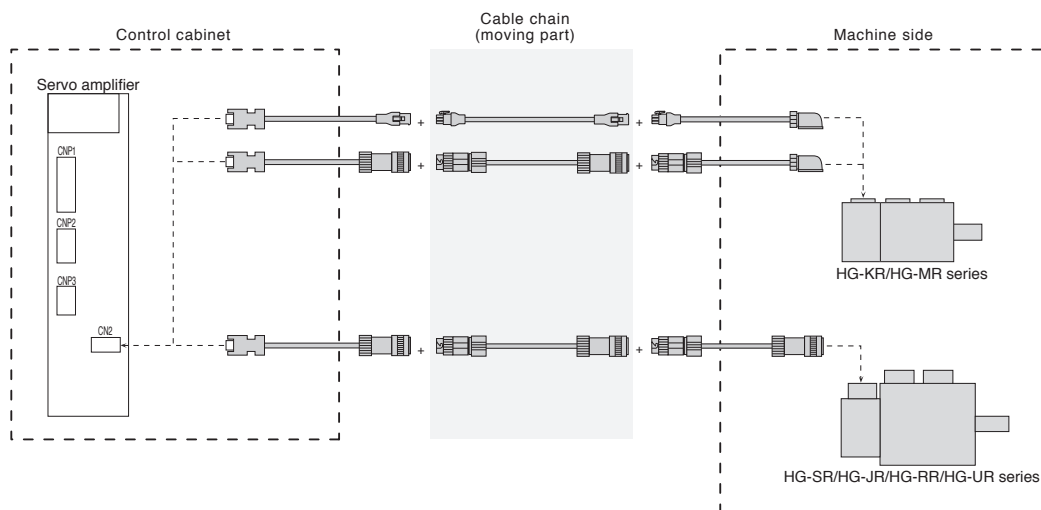

Products on the Market for Servo Amplifiers

Mitsubishi Electric Engineering

Network amplifier junction terminal block



Features

- The spring clamp type reduces the installation area by about 40 % compared to the screw type.\*
- When multiple servo amplifiers are connected, the interface power supply can be connected in series across terminal blocks.

Connection with servo amplifier

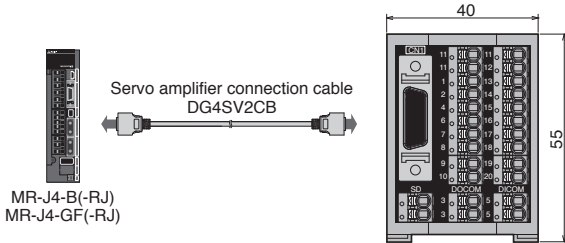

Dimensions

■ DG2SV3TB

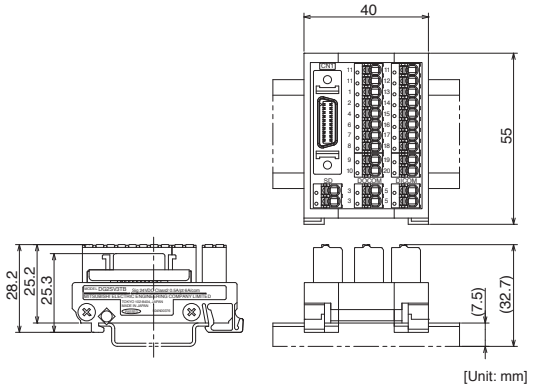

Product models

Item	Model	Description
Network amplifier junction terminal block	DG2SV3TB	For network-connectable 1-axis servo amplifier, sink/source common type External power supply voltage: 24 V DC ± 10 % Maximum usable current: 0.5 A for signal / 6 A for common line
	DG4SV2CB05	Length: 0.5 m
	DG4SV2CB10	Length: 1 m
Servo amplifier connection cable	DG4SV2CB50	Length: 5 m

\* Based on the research of Mitsubishi Electric Engineering.

Junction terminal block for servo motors with brakes

Features

- Easy to build a brake sequence circuit recommended for MR-J4-B/GF servo amplifiers.
- The new terminal block reduces the installation area by up to 50 % compared to preceding types. In addition, fewer wires are required inside the cabinet.

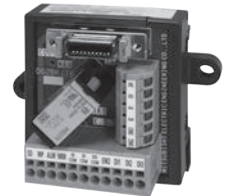

Connection with servo amplifier

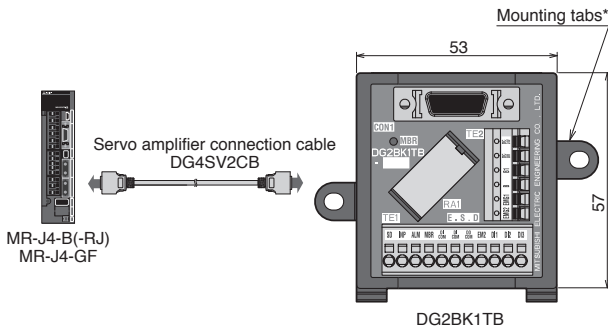

Dimensions

■ DG2BK1TB

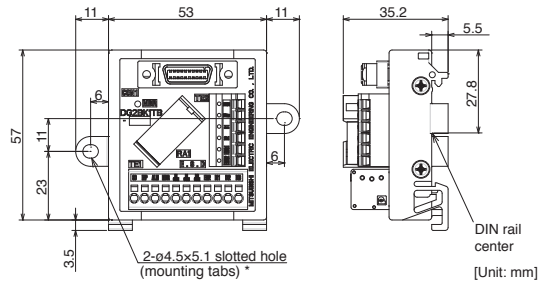

\* The DG2BK1TB-D is without mounting tabs.

\* The DG2BK1TB-D is without mounting tabs.

Product models

Item	Model	Description
Junction terminal block for motor with brake For network-connectable 1-axis servo amplifier Sink/source common type	DG2BK1TB	Screw mounting/ DIN rail installation
	DG2BK1TB-D	For DIN rail installation
Servo amplifier connection cable	DG4SV2CB05	Length: 0.5 m
	DG4SV2CB10	Length: 1 m
	DG4SV2CB50	Length: 5 m

Servo Amplifiers

Rotary Servo Motors

Linear Servo Motors

Direct Drive Motors

Options/Peripheral Equipment

LVS/Wires

Product List

Precautions

# Options/Peripheral Equipment

## FLS/RLS/DOG signal-specialized network amplifier terminal block



### Features

- Compact terminal blocks designed specifically for the FLS/RLS (stroke limit) and DOG (proximity dog) signals.
- Long cables are available to install the terminal block near the machine. (Long bending life cables are also available.)

### Connection with servo amplifier

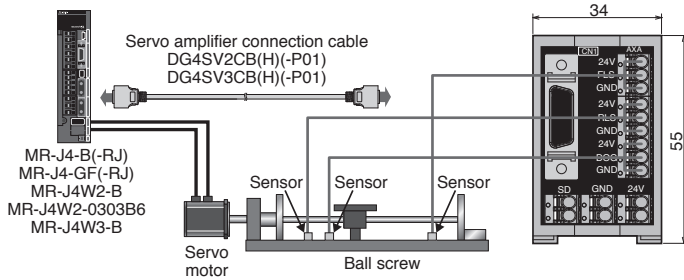

### Dimensions

#### ■ DG2SV2TB (for 1-axis servo amplifier)

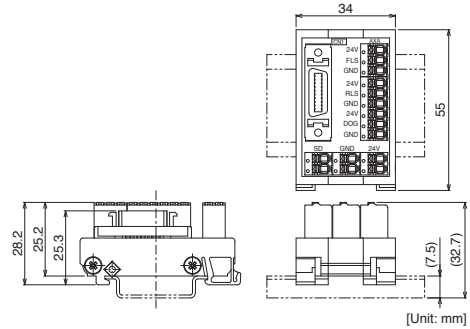

### Dimensions

#### ■ DG2SV2TB2 (for 2-axis servo amplifier)

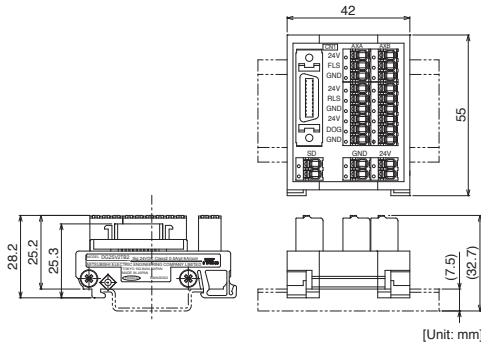

### Dimensions

#### ■ DG2SV2TB3 (for 3-axis servo amplifier)

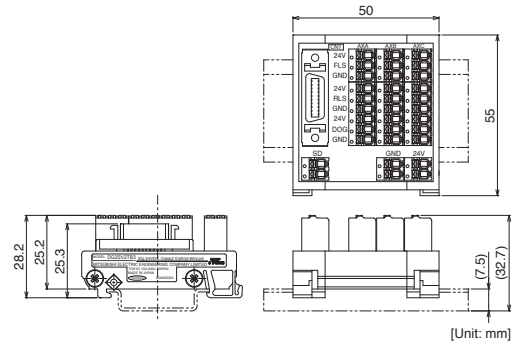

### Product models

Item	Model	Description	
FLS/RLS/DOG signal-specialized network amplifier terminal block (for 1-axis servo amplifier)	DG2SV2TB	For network-connectable 1-axis servo amplifier Sink/source common type, dedicated for FLS/RLS/DOG signals External power supply voltage: 24 V DC ± 10 % Maximum usable current: 0.5 A for signal / 6 A for common line	
	DG4SV2CB05	Length: 0.5 m	
	DG4SV2CB10	Length: 1 m	
	DG4SV2CB50	Length: 5 m	
	DG4SV2CB50H	Length: 5 m	
	DG4SV2CB100H	Length: 10 m	
	DG4SV2CB05-P01	Length: 0.5 m	
FLS/RLS/DOG signal-specialized network amplifier terminal block (for 2-axis/3-axis servo amplifier)	DG2SV2TB2	For network-connectable 2-axis servo amplifier Sink/source common type, dedicated for FLS/RLS/DOG signals External power supply voltage: 24 V DC ± 10 % Maximum usable current: 0.5 A for signal / 6 A for common line	
	DG2SV2TB3	For network-connectable 3-axis servo amplifier Sink/source common type, dedicated for FLS/RLS/DOG signals External power supply voltage: 24 V DC ± 10 % Maximum usable current: 0.5 A for signal / 6 A for common line	
	DG4SV3CB05	Length: 0.5 m	
	DG4SV3CB10	Length: 1 m	
	DG4SV3CB50	Length: 5 m	
	DG4SV3CB50H	Length: 5 m	
	DG4SV3CB100H	Length: 10 m	
Sink-interface servo amplifier connection cable (for 2-axis/3-axis servo amplifier / long bending life)	DG4SV3CB05-P01	Length: 0.5 m	
	DG4SV3CB10-P01	Length: 1 m	
	DG4SV3CB50-P01	Length: 5 m	
	DG4SV3CB50H-P01	Length: 5 m	
	Source-interface servo amplifier connection cable (for 2-axis/3-axis servo amplifier / long bending life)	DG4SV3CB100H-P01	Length: 10 m
		DG4SV3CB05-P01	Length: 0.5 m
		DG4SV3CB10-P01	Length: 1 m
Source-interface servo amplifier connection cable (for 2-axis/3-axis servo amplifier / long bending life)	DG4SV3CB50-P01	Length: 5 m	
	DG4SV3CB50H-P01	Length: 5 m	
	DG4SV3CB100H-P01	Length: 10 m	

Servo amplifier connection cable for pulse train Positioning modules

**Features**

- This servo amplifier connection cable for pulse train Positioning modules enables easy wiring when the MELSEC Positioning module is used to control the MR-J4-A.



**Dimensions**

■ FA-CBLQ75M2J3, FA-CBLQ75PM2J3

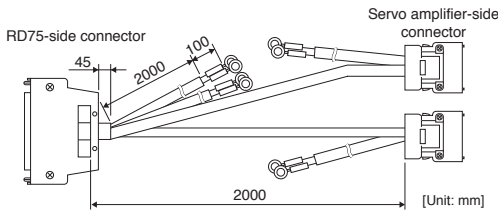

■ FA-CBLQ75M2J3-P

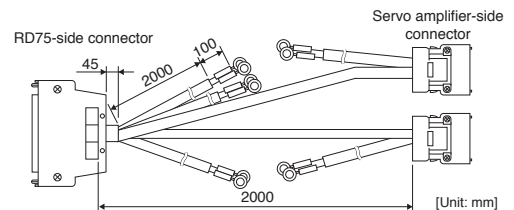

**Product models**

Item	Model	Description
Servo amplifier connection cable for pulse train Positioning modules	FA-CBLQ75M2J3-P	Supported Positioning module: RD75D2, RD75D4, FX5-20PG-D Length: 2 m, with pulsar cables
	FA-CBLQ75M2J3	Supported Positioning module: RD75D2, RD75D4, FX5-20PG-D Length: 2 m, without pulsar cables
	FA-CBLQ75PM2J3	Supported Positioning module: RD75P2, RD75P4, FX5-20PG-P Length: 2 m, without pulsar cables

General-purpose interface amplifier junction terminal block

**Features**

- The spring clamp type reduces the installation area by approximately 50 % compared to the screw type. \*
- When multiple servo amplifiers are connected, the interface power supply can be connected in series across up to four terminal blocks.

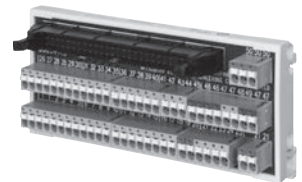

**Connection with servo amplifier \*1**

**Dimensions**

■ DG2SV1TB

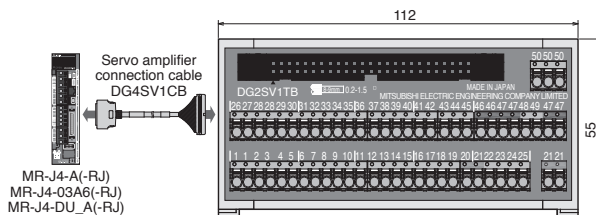

\*1: This can also be used for MR-D01.

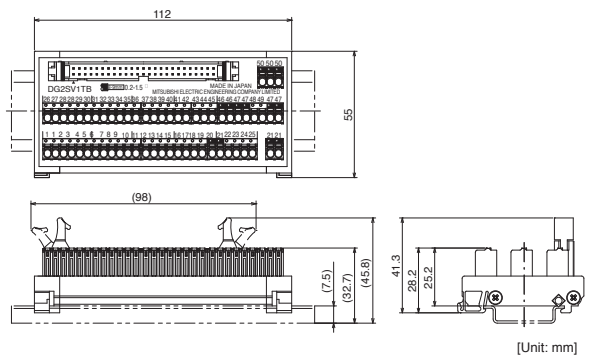

**Product models**

Item	Model	Description
General-purpose interface amplifier junction terminal block	DG2SV1TB	For general-purpose interface servo amplifier, sink/source common type External power supply voltage: 24 V DC $\pm$ 10 %, current capacity 1 A (max.)
	Servo amplifier connection cable	DG4SV1CB05
DG4SV1CB10		Length: 1 m

\* Based on the research of Mitsubishi Electric Engineering.

For inquiries about Mitsubishi Electric Engineering products, please contact us at the following email address. (Supported languages: English and Japanese).  
fagoods.products.faq@mitsubishielectricengineering.com

Servo Amplifiers  
Rotary Servo Motors  
Linear Servo Motors  
Direct Drive Motors  
Options/Peripheral Equipment  
LV5/Wires  
Product List  
Precautions

## Options/Peripheral Equipment

MEMO



## Functional Safety Unit (MR-D30) (Note 7)

GF-RJ B-RJ B-RJ100 A-RJ

## Specifications

A combination of MR-D30 functional safety unit and MR-J4-GF-RJ/MR-J4-B-RJ/MR-J4-A-RJ servo amplifier or MR-J4-DU\_B-RJ/MR-J4-DU\_A-RJ drive unit expands the safety sub-function. (Note 4)

Model		MR-D30
Output	Rated voltage	24 V DC
	Rated current [A]	0.3
Interface power supply	Voltage	24 V DC ± 10%
	Power supply capacity [A]	0.8
Safety performance	Satisfied standards	ISO 13849-1:2015 Category 4 PL e and Category 3 PL d IEC 61508 SIL 2 and SIL 3 IEC 62061 maximum SIL 2 and SIL 3 IEC 61800-5-2
	Mean time to dangerous failure	MTTFd ≥ 100 [years] (313a)
	Effectiveness of safety observation system or safety observation subsystem	DC = High, 97.6 [%]
	Probability of dangerous Failure per Hour	PFH = 6.57 × 10 <sup>-9</sup> [1/h]
	Mission time	TM = 20 [years]
	Response performance (Note 1)	Using input device: 15 ms or less
	Speed observation resolution	Depends on a command resolution (0.1 r/min or less at 22-bit position command)
	Position observation resolution	1/32 rev
	Input device	6 points × 2 systems (source/sink)
	Output device	Source: 3 points × 2 systems and 1 point × 1 system Sink: 1 point × 1 system
Safety sub-function (IEC 61800-5-2)	Safe torque off (STO)	Category 4 PL e, SIL 3 (Note 2)/Category 3 PL d, SIL 2
	Safe stop 1 (SS1)	Category 4 PL e, SIL 3 (Note 2)/Category 3 PL d, SIL 2
	Safe stop 2 (SS2) (Note 4, 5)	Category 4 PL e, SIL 3 (Note 2)/Category 3 PL d, SIL 2
	Safe operating stop (SOS) (Note 4, 5)	Category 4 PL e, SIL 3 (Note 2)/Category 3 PL d, SIL 2
	Safely-limited speed (SLS) (Note 4)	Category 4 PL e, SIL 3 (Note 2, 3)/Category 3 PL d, SIL 2
	Safe brake control (SBC)	Category 4 PL e, SIL 3 (Note 2)/Category 3 PL d, SIL 2
	Safe speed monitor (SSM) (Note 4)	Category 4 PL e, SIL 3 (Note 2, 3)/Category 3 PL d, SIL 2
	Status monitor (Note 6)	Category 4 PL e, SIL 3/Category 3 PL d, SIL 2
Satisfied standards	CE marking EMC: EN 61800-3 MD: EN ISO 13849-1:2015, EN 61800-5-2, EN IEC 62061	
Structure (IP rating)	Natural cooling, open (IP20 when mounted on servo amplifier and IP00 for MR-D30 alone)	
Environment	Ambient temperature	Operation: 0 °C to 55 °C (non-freezing), storage: -20 °C to 65 °C (non-freezing)
	Ambient humidity	Operation/Storage: 5 %RH to 90 %RH (non-condensing)
	Ambience	Indoors (no direct sunlight); no corrosive gas, inflammable gas, oil mist or dust
	Altitude	2000 m or less above sea level
	Vibration resistance	5.9 m/s <sup>2</sup> at 10 Hz to 57 Hz
Mass [kg]	0.15	

Notes: 1. Time from STO input to energy shut off.

2. To meet Category 4 PL e, SIL 3, an input diagnosis using test pulse is required.

3. To meet Category 4 PL e, SIL 3, a combination with HG-KR\_W0C, HG-SR\_W0C, or HG-JR\_W0C servo motor is required.

4. Linear servo system, direct drive servo system, and fully closed loop control system do not support SLS, SSM, SS2, and SOS.

5. To achieve SS2 and SOS, a combination with HG-KR\_W0C, HG-SR\_W0C, or HG-JR\_W0C servo motor is required.

6. The status monitor is an original function of Mitsubishi Electric. Refer to "MR-D30 Instruction Manual" for the achievable safety level and the types of the status monitor.

7. This is not supported by MR-J4-03A6(-RJ).

## Options/Peripheral Equipment

### Functional Safety Unit (MR-D30)

**GF-RJ** **B-RJ** **B-RJ100** **A-RJ**

#### List of compatible software version

Achievable safety sub-function depends on the software versions of MR-D30 and the servo amplifier, and compatibility of the servo motor with functional safety. Refer to the table below:

For MR-J4-GF-RJ

#### Safety sub-function control by input device

MR-D30 software version	Servo amplifier software version	Safety sub-function (IEC/EN 61800-5-2)	Servo motors with functional safety	Servo amplifier
A1 or later	A3 or later	STO/SS1/SBC/SLS/SSM/SOS/SS2	HG-KR_W0C HG-SR_W0C HG-JR_W0C	MR-J4- <u>GF</u> -RJ

#### Safety sub-function control by network

MR-D30 software version	Servo amplifier software version	Safety sub-function (IEC/EN 61800-5-2)	Servo motors with functional safety	Servo amplifier
A2 or later	A3 or later	STO/SS1/SBC/SLS/SSM/SOS/SS2	HG-KR_W0C HG-SR_W0C HG-JR_W0C	MR-J4- <u>GF</u> -RJ

For MR-J4-B-RJ/MR-J4-DU-B-RJ/MR-J4-A-RJ/MR-J4-DU-A-RJ

MR-D30 software version	Servo amplifier software version	Safety sub-function (IEC/EN 61800-5-2)	Servo motors with functional safety	Servo amplifier
A0	B3 or later	STO/SS1/SBC/SLS/SSM	Not compatible	MR-J4- <u>B</u> -RJ
A1 or later	B3/B4	STO/SS1/SBC/SLS/SSM	Not compatible	MR-J4- <u>B</u> -RJ
	B5 or later	STO/SS1/SBC/SLS/SSM/SOS/SS2	HG-KR_W0C HG-SR_W0C HG-JR_W0C	MR-J4- <u>B</u> -RJ MR-J4- <u>A</u> -RJ (Note 1) MR-J4-DU- <u>B</u> -RJ MR-J4-DU- <u>A</u> -RJ (Note 2)

Notes: 1. MR-D30 is compatible with MR-J4-A-RJ manufactured in November 2014 or later.

2. MR-D30 is compatible with MR-J4-DU-A-RJ manufactured in January 2015 or later.

## Functional Safety Unit (MR-D30)

GF-RJ B-RJ B-RJ100 A-RJ

## Connection Example

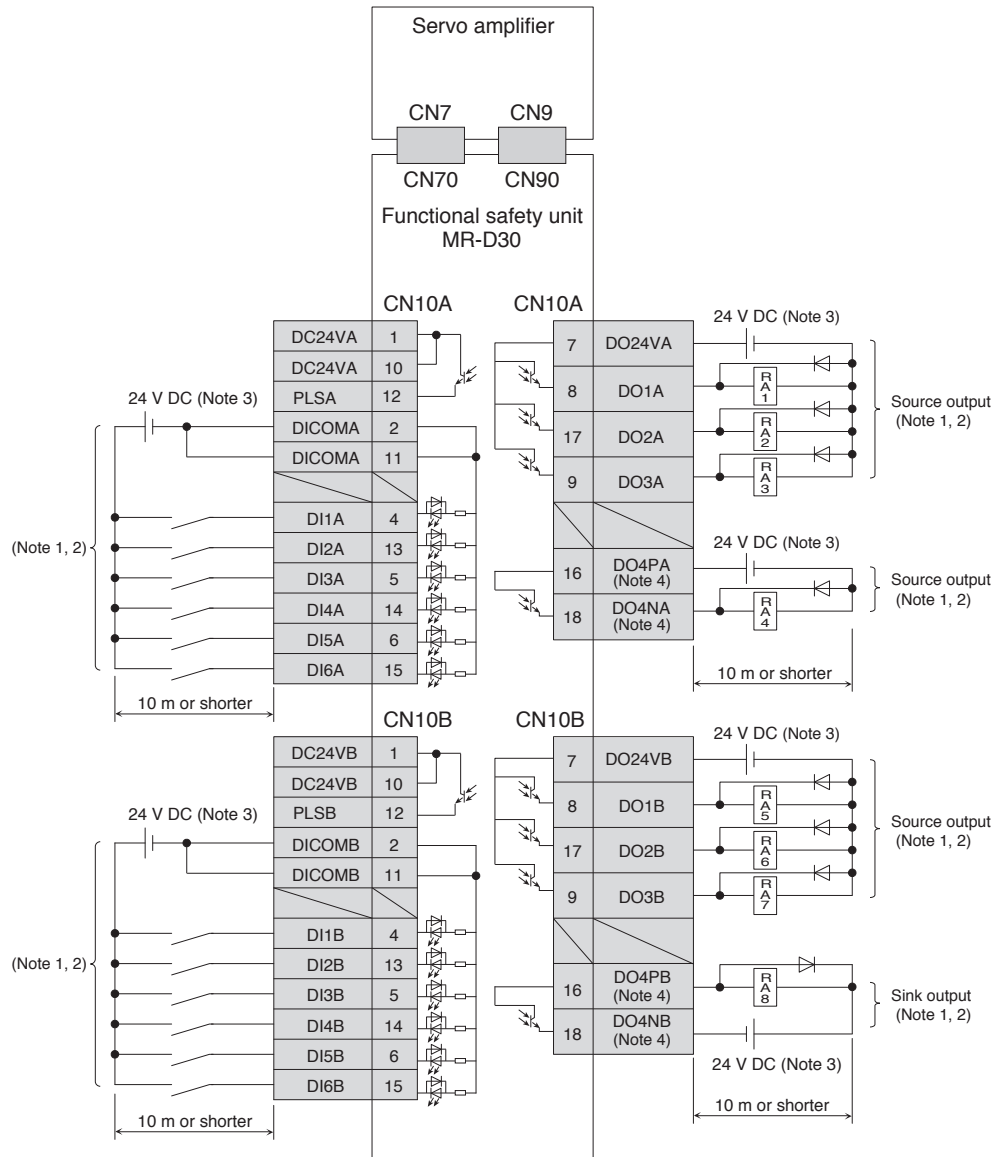

Notes: 1. Separate all of the external wirings into two systems. Connect separately even for the input and output power supply (24 V DC and 0 V common) connection. Do not wire between CN10A and CN10B.

2. Assign each input/output device by the combination of connector pins shown in the table below. Refer to "MR-D30 Instruction Manual" for each device.

Combination for input connector pin	Combination for output connector pin
DI1A (CN10A-4)/DI1B (CN10B-4)	DO1A (CN10A-8)/DO1B (CN10B-8)
DI2A (CN10A-13)/DI2B (CN10B-13)	DO2A (CN10A-17)/DO2B (CN10B-17)
DI3A (CN10A-5)/DI3B (CN10B-5)	DO3A (CN10A-9)/DO3B (CN10B-9)
DI4A (CN10A-14)/DI4B (CN10B-14)	DO4NA (CN10A-18)/DO4PB (CN10B-16)
DI5A (CN10A-6)/DI5B (CN10B-6)	
DI6A (CN10A-15)/DI6B (CN10B-15)	

3. Provide an external power supply of 24 V DC  $\pm$  10% for the interface. When all input/output points are used, the total current capacity of 0.8 A is required. For convenience of illustration, the diagram shows separate 24 V DC power supplies for input and output signals. However, the input and output signals can share a common power supply.

4. DO4PA (CN10A-16), DO4NA (CN10A-18), DO4PB (CN10B-16) and DO4NB (CN10B-18) are not available with MR-D30 manufactured in September 2014 or earlier. Do not connect anything to these pins.

Servo Amplifiers

Rotary Servo Motors

Linear Servo Motors

Direct Drive Motors

Options/Peripheral Equipment

LV/S/Wires

Product List

Precautions

# Options/Peripheral Equipment

## Functional Safety Unit (MR-D30)

GF-RJ B-RJ B-RJ100 A-RJ

### Dimensions

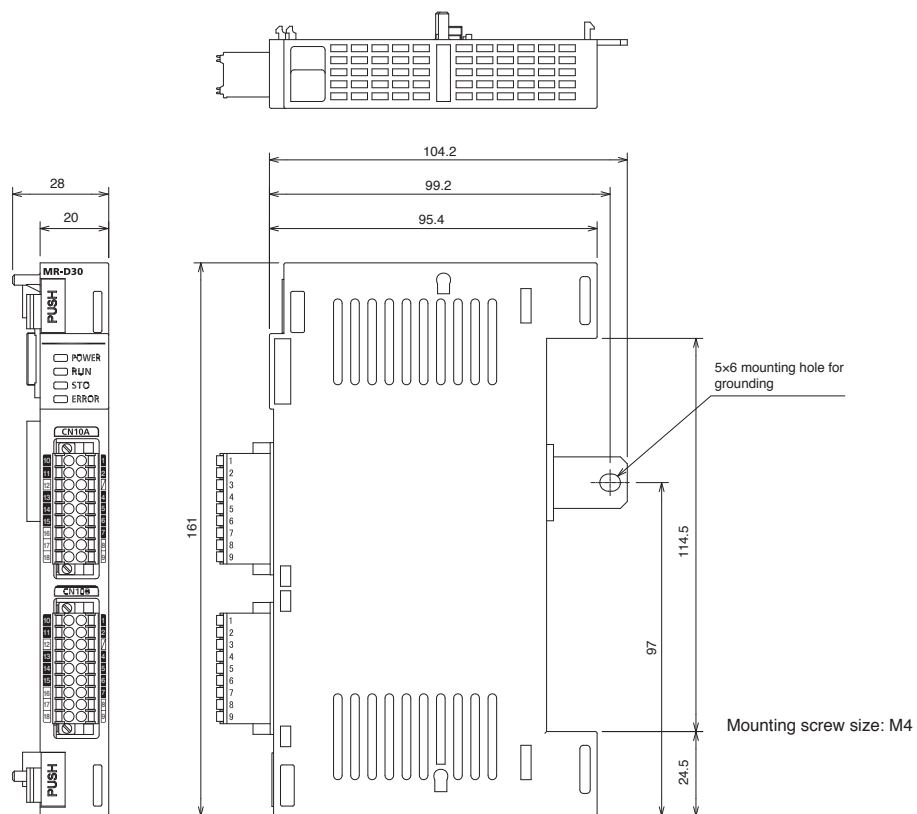

[Unit: mm]

**Safety Logic Unit (MR-J3-D05)** (Note 5)

GF	GF-RJ	B	B-RJ	WB	A	A-RJ
----	-------	---	------	----	---	------

The safety logic unit (MR-J3-D05) has SS1 (Safe Stop1) and STO functions. A combination of the servo amplifier and the safety logic unit achieves SS1 function.

## Specifications

Safety logic unit model		MR-J3-D05
Control circuit power supply	Voltage	24 V DC
	Permissible voltage fluctuation	24 V DC $\pm$ 10%
	Required current capacity [A]	0.5 (Note 1, 2)
Compatible system		2 systems (A-axis, B-axis independent)
Shut-off input		4 points (2 points $\times$ 2 systems) SDI_ : source/sink compatible (Note 3)
Shut-off release input		2 points (1 point $\times$ 2 systems) SRES_ : source/sink compatible (Note 3)
Feedback input		2 points (1 point $\times$ 2 systems) TOF_ : source compatible (Note 3)
Input type		Photocoupler insulation, 24 V DC (external supply), internal limited resistance 5.4 k $\Omega$
Shut-off output		8 points (4 points $\times$ 2 systems) STO_ : source compatible (Note 3) SDO_ : source/sink compatible (Note 3)
Output type		Photocoupler insulation, open-collector type Permissible current: 40 mA or less per output, Inrush current: 100 mA or less per output
Delay time setting		A-axis: select from 0 s, 1.4 s, 2.8 s, 5.6 s, 9.8 s or 30.8 s B-axis: select from 0 s, 1.4 s, 2.8 s, 9.8 s or 30.8 s Accuracy: $\pm$ 2%
Functional safety		STO, SS1 (IEC/EN 61800-5-2) EMG STOP, EMG OFF (IEC/EN 60204-1)
Safety performance	Satisfied standards	ISO 13849-1:2015 Category 3 PL d, IEC 61508 SIL 2, IEC 62061 maximum SIL 2, IEC 61800-5-2
	Response performance (when delay time is set to 0 s) (Note 4)	10 ms or less (STO input OFF $\rightarrow$ shut-off output OFF)
	Mean time to dangerous failure (MTTFd)	MTTFd $\geq$ 100 [years] (516a)
	Diagnostic coverage (DC)	DC = Medium, 93.1 [%]
Satisfied standards	CE marking	LVD: EN 61800-5-1 EMC: EN 61800-3 MD: EN ISO 13849-1:2015, EN 61800-5-2, EN IEC 62061
	Structure (IP rating)	Natural cooling, open (IP00)
Environment	Ambient temperature	Operation: 0 $^{\circ}$ C to 55 $^{\circ}$ C (non-freezing), storage: -20 $^{\circ}$ C to 65 $^{\circ}$ C (non-freezing)
	Ambient humidity	Operation/storage: 5 %RH to 90 %RH (non-condensing)
	Ambience	Indoors (no direct sunlight); no corrosive gas, inflammable gas, oil mist or dust
	Altitude	1000 m or less above sea level
Mass	Vibration resistance	5.9 m/s <sup>2</sup> at 10 Hz to 55 Hz (directions of X, Y and Z axes)
	[kg]	0.2 (including CN9 and CN10 connectors)

Notes: 1. Inrush current of approximately 1.5 A flows instantaneously when the power is switched on. Select an appropriate capacity of a power supply considering the inrush current.

2. Power-on duration of the safety logic unit is 100,000 times.

3. \_ in signal name indicates a number and axis name.

4. Contact your local sales office for test pulse input.

5. This is not supported by MR-J4W2-0303B6 and MR-J4-03A6(-RJ).

Servo Amplifiers

Rotary Servo Motors

Linear Servo Motors

Direct Drive Motors

Options/Peripheral Equipment

LVSWires

Product List

Precautions

# Options/Peripheral Equipment

## Safety Logic Unit (MR-J3-D05)

GF GF-RJ B B-RJ WB A A-RJ

### Connection example

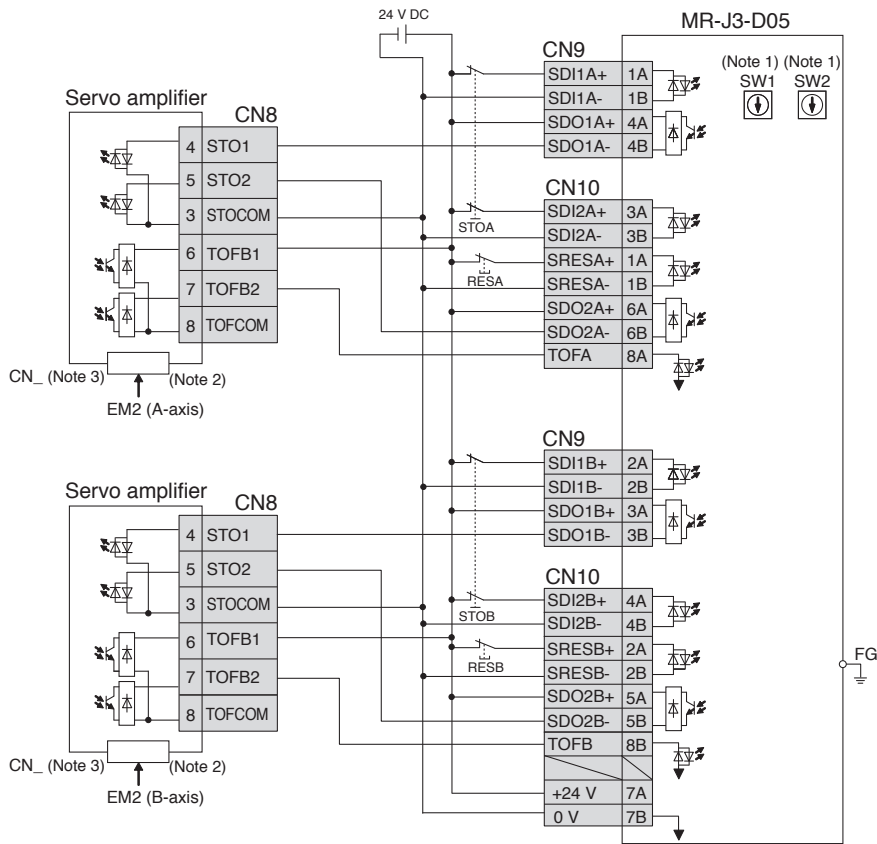

- Notes: 1. Set delay time of STO output with SW1 and SW2.  
 2. This connection is for source interface.  
 3. This connector is CN3 for MR-J4-GF(-RJ)/MR-J4-B(-RJ)/MR-J4-DU\_B(-RJ)/MR-J4W\_-B, and CN1 for MR-J4-A(-RJ)/MR-J4-DU\_A(-RJ).

### Dimensions

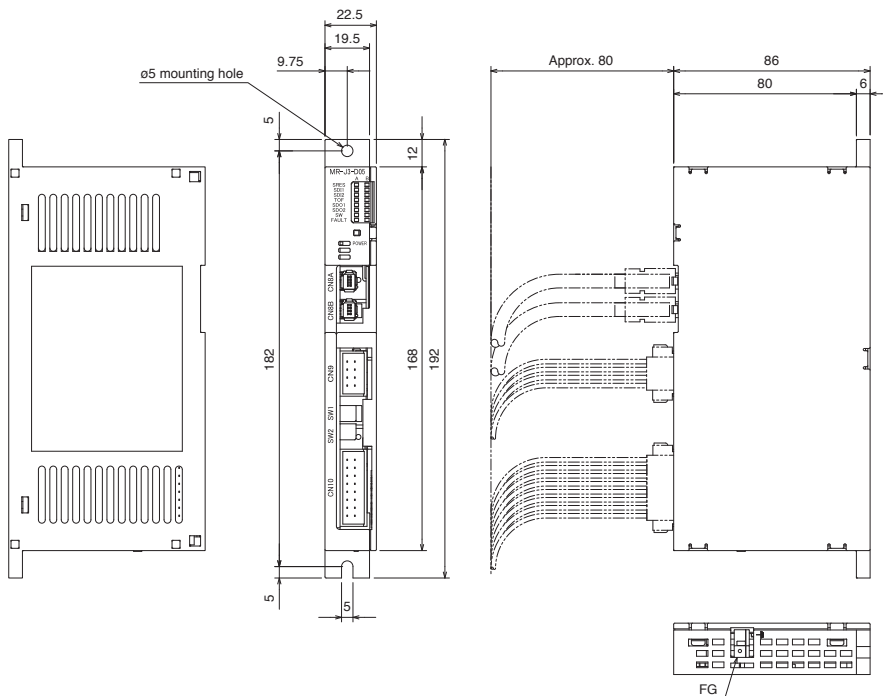

Mounting screw size: M4

[Unit: mm]

**Extension IO Unit (MR-D01)** (Note 3)

Digital/analog inputs and outputs can be increased by combining extension IO unit (MR-D01).

## Specification

Extension IO unit model		MR-D01
Interface power supply		24 V DC $\pm 10\%$ (required current capacity: 0.8 A <sup>(Note 1)</sup> )
Digital input		30 points, photocoupler insulation, sink/source compatible
Digital output		16 points, photocoupler insulation, sink/source compatible
Analog input		2 channels, 0 V DC to $\pm 10$ V DC (input impedance: 10 k $\Omega$ to 12 k $\Omega$ )
Analog output		2 channels, 0 V DC to $\pm 12$ V DC
Power supply for analog input signal		P15R: +15 V DC, permissible current: 30 mA <sup>(Note 2)</sup> N12R: -12 V DC, permissible current: 30 mA <sup>(Note 2)</sup>
Structure (IP rating)		Natural cooling, open (IP00)
Environment	Ambient temperature	Operation: 0 °C to 55 °C (non-freezing), storage: -20 °C to 65 °C (non-freezing)
	Ambient humidity	Operation/storage: 5 %RH to 90 %RH (non-condensing)
	Ambience	Indoors (no direct sunlight); no corrosive gas, inflammable gas, oil mist or dust
	Altitude	1000 m or less above sea level
	Vibration resistance	5.9 m/s <sup>2</sup> at 10 Hz to 55 Hz (directions of X, Y and Z axes)
Mass	[g]	140

- Notes: 1. A 24 V DC power supply for input/output signals can be shared by the servo amplifier and MR-D01. In this case, secure the power supply capacity corresponding to the points of the input/output signals to be used.
2. P15R can be used as a power supply for TLA and VC. N12R can be used as a power supply for VC. Note that the power voltage varies between -12 V to -15 V.
3. MR-D01 extension IO unit is supported by MR-J4-\_A\_-RJ servo amplifiers with software version B7 or later. Note that MR-D01 is not supported by MR-J4-03A6(-RJ) and the drive unit.

## Dimensions

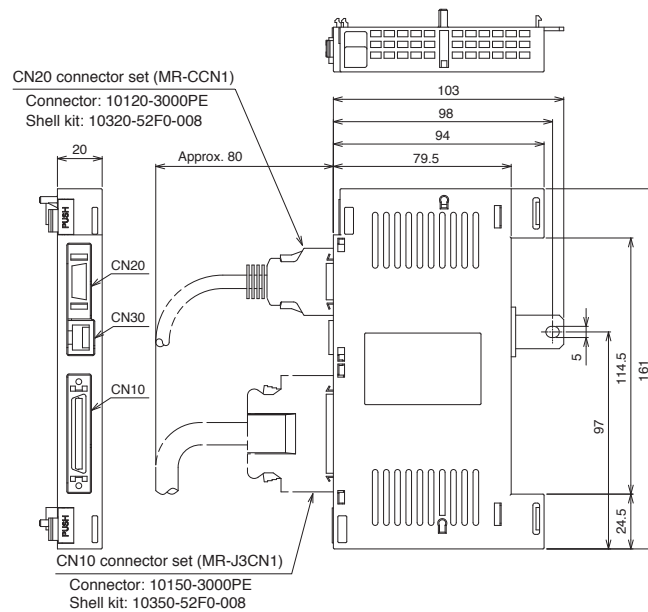

Extension IO Unit (MR-D01): Connection Example (Point Table Positioning Operation)

A-RJ

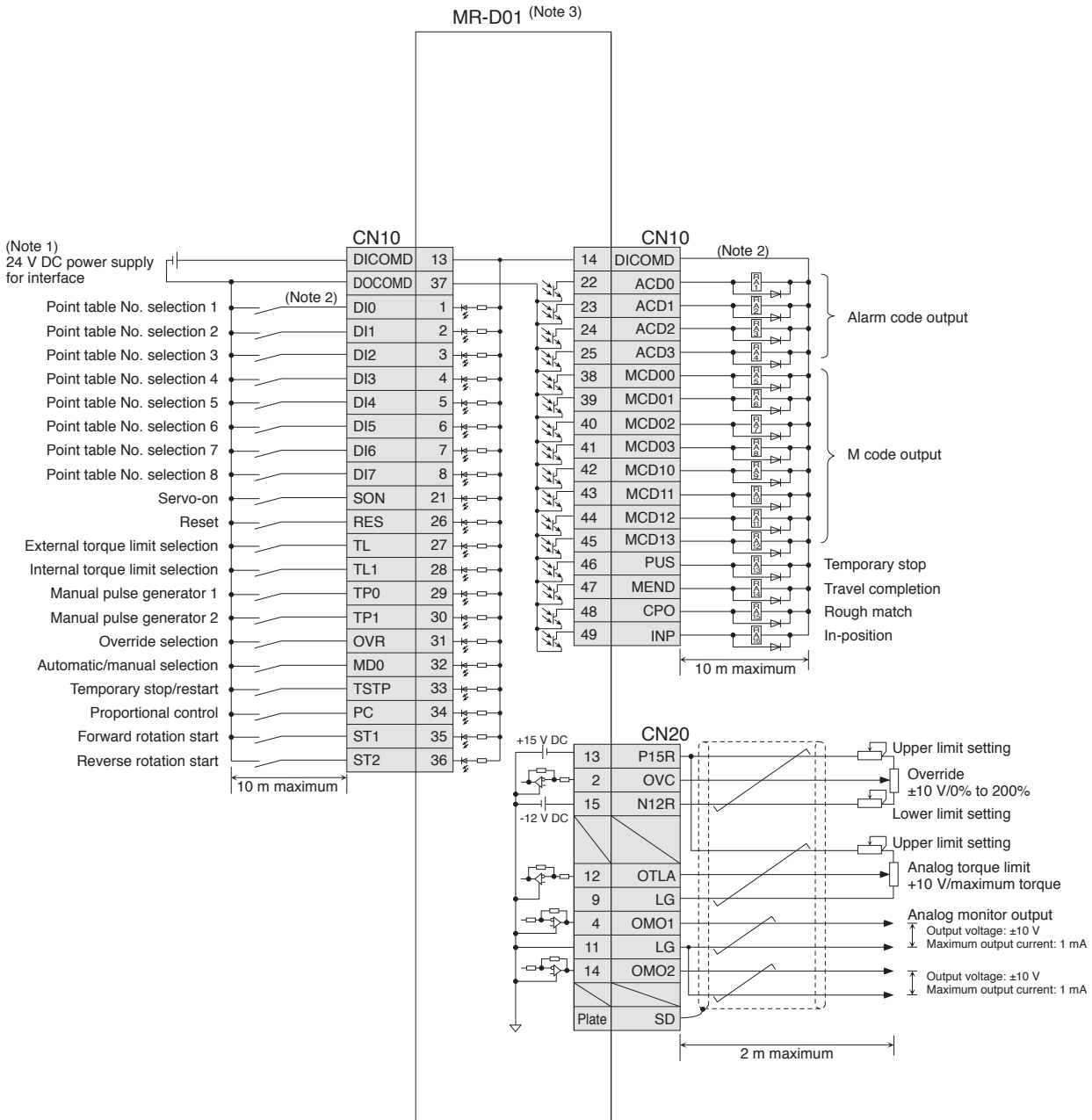

- Notes: 1. A 24 V DC power supply for input/output signals can be shared by the servo amplifier and MR-D01. In this case, secure the power supply capacity corresponding to the points of the input/output signals to be used.  
 2. This is for sink wiring. Source wiring is also possible. Refer to "MR-J4-\_A\_-RJ MR-J4-03A6-RJ Servo Amplifier Instruction Manual (Positioning Mode)" for details.  
 3. MR-D01 connects directly to CN7 connector of MR-J4-\_A\_-RJ.



## Regenerative Option

GF GF-RJ B B-RJ WB A A-RJ

200 V/100 V

Servo amplifier model	Permissible regenerative power [W] <sup>(Note 3)</sup>																		
	Built-in regenerative resistor	External regenerative resistor (standard accessory) <sup>(Note 5)</sup>			Regenerative option														
		GRZG400-			MR-RB														
		0.8 Ω × 4 <sup>(Note 2)</sup>	0.6 Ω × 5 <sup>(Note 2)</sup>	0.5 Ω × 5 <sup>(Note 2)</sup>	032	12	30 <sup>(Note 6)</sup>	3N <sup>(Note 6)</sup>	31 <sup>(Note 6)</sup>	32 <sup>(Note 6)</sup>	50 <sup>(Note 1)</sup>	5N <sup>(Note 1)</sup>	51 <sup>(Note 1)</sup>	5R <sup>(Note 2)</sup>	9F <sup>(Note 2)</sup>	9T <sup>(Note 2)</sup>	14	34 <sup>(Note 6)</sup>	
				40 Ω	40 Ω	13 Ω	9 Ω	6.7 Ω	40 Ω	13 Ω	9 Ω	6.7 Ω	3.2 Ω	3 Ω	2.5 Ω	26 Ω	26 Ω		
MR-J4-10GF/B/A MR-J4-10GF1/ B1/A1	-	-	-	30	-	-	-	-	-	-	-	-	-	-	-	-	-		
MR-J4-20GF/B/A MR-J4-20GF1/ B1/A1	10	-	-	30	100	-	-	-	-	-	-	-	-	-	-	-	-		
MR-J4-40GF/B/A MR-J4-40GF1/ B1/A1	10	-	-	30	100	-	-	-	-	-	-	-	-	-	-	-	-		
MR-J4-60GF/B/A	10	-	-	30	100	-	-	-	-	-	-	-	-	-	-	-	-		
MR-J4-70GF/B/A	20	-	-	30	100	-	-	-	300	-	-	-	-	-	-	-	-		
MR-J4-100GF/B/A	20	-	-	30	100	-	-	-	300	-	-	-	-	-	-	-	-		
MR-J4-200GF/B/A	100	-	-	-	-	300	-	-	-	500	-	-	-	-	-	-	-		
MR-J4-350GF/B/A	100	-	-	-	-	-	300	-	-	-	500	-	-	-	-	-	-		
MR-J4-500GF/B/A	130	-	-	-	-	-	-	300	-	-	-	500	-	-	-	-	-		
MR-J4-700GF/B/A	170	-	-	-	-	-	-	300	-	-	-	500	-	-	-	-	-		
MR-J4-11KGF/B/A	-	500 (800)	-	-	-	-	-	-	-	-	-	-	500 (800)	-	-	-	-		
MR-J4-15KGF/B/A	-	-	850 (1300)	-	-	-	-	-	-	-	-	-	-	850 (1300)	-	-	-		
MR-J4-22KGF/B/A	-	-	-	850 (1300)	-	-	-	-	-	-	-	-	-	-	850 (1300)	-	-		
MR-J4W2-22B	20	-	-	-	-	-	-	-	-	-	-	-	-	-	-	100	-		
MR-J4W2-44B	20	-	-	-	-	-	-	-	-	-	-	-	-	-	-	100	-		
MR-J4W2-77B	100	-	-	-	-	-	300	-	-	-	-	-	-	-	-	-	-		
MR-J4W2-1010B	100	-	-	-	-	-	300	-	-	-	-	-	-	-	-	-	-		
MR-J4W3-222B	30	-	-	-	-	-	-	-	-	-	-	-	-	-	-	100	300		
MR-J4W3-444B	30	-	-	-	-	-	-	-	-	-	-	-	-	-	-	100	300		

Resistance regeneration converter unit model	Drive unit model	Permissible regenerative power [W] of regenerative option <sup>(Note 3)</sup>	
		MR-RB139	MR-RB137
		1.3 Ω	1.3 Ω <sup>(Note 4)</sup>
MR-CR55K	MR-J4-DU30KB/A MR-J4-DU37KB/A	1300	3900

Notes: 1. Be sure to cool the unit forcibly with a cooling fan (92 mm × 92 mm, minimum air flow: 1.0 m<sup>3</sup>/min). The cooling fan must be prepared by user.

2. The value in brackets is applicable when cooling fans (two units of 92 mm × 92 mm, minimum air flow: 1.0 m<sup>3</sup>/min) are installed, and then [Pr. PA02] is changed.

3. The power values in this table are resistor-generated powers, not rated powers.

4. This is the resultant resistance when three units of MR-RB137 are connected in parallel.

5. The regenerative resistor enclosed with the servo amplifiers 11 kW to 22 kW does not have a protective cover, and touching the resistor (including the wiring screws) may cause a burn or an electric shock. Provide safety measures such as a protective cover or use MR-RB\_ regenerative option.

6. Depending on the operating environment, it may be necessary to cool the unit forcibly with a cooling fan (92 mm × 92 mm, minimum air flow: 1.0 m<sup>3</sup>/min).

Refer to relevant Servo Amplifier Instruction Manual for details. The cooling fan must be prepared by users.

## \* Precautions when mounting/connecting the regenerative option

- The regenerative option causes a temperature rise of 100 °C or higher relative to the ambient temperature. Fully examine heat dissipation, installation position, wires used before installing the unit. Use flame-retardant wires or apply flame retardant on wires, and keep the wires clear of the unit.
- Use twisted wires for connecting the regenerative option to the servo amplifier, and keep the wire length to a maximum of 5 m.
- Use twisted wires for connecting a thermal sensor, and make sure that the sensor does not fail to work properly due to inducted noise.
- There are restrictions on the mounting direction of the regenerative option. Refer to relevant Servo Amplifier Instruction Manual for details.

## Regenerative Option

GF GF-RJ B B-RJ WB A A-RJ

400 V

Servo amplifier model	Permissible regenerative power [W] <sup>(Note 4)</sup>												
	Built-in regenerative resistor	External regenerative resistor (standard accessory) <sup>(Note 6)</sup>		Regenerative option									
		GRZG400-		MR-RB									
		2.5 Ω × 4 <sup>(Note 2)</sup>	2 Ω × 5 <sup>(Note 2)</sup>	1H-4	3M-4 <sup>(Note 1)</sup>	3G-4 <sup>(Note 1)</sup>	34-4 <sup>(Note 1)</sup>	3U-4 <sup>(Note 1)</sup>	5G-4 <sup>(Note 1)</sup>	54-4 <sup>(Note 1)</sup>	5U-4 <sup>(Note 1)</sup>	5K-4 <sup>(Note 2)</sup>	6K-4 <sup>(Note 2)</sup>
				82 Ω	120 Ω	47 Ω	26 Ω	22 Ω	47 Ω	26 Ω	22 Ω	10 Ω	10 Ω
MR-J4-60GF4/B4/A4	15	-	-	100	300	-	-	-	-	-	-	-	-
MR-J4-100GF4/B4/A4	15	-	-	100	300	-	-	-	-	-	-	-	-
MR-J4-200GF4/B4/A4	100	-	-	-	-	300	-	-	500	-	-	-	-
MR-J4-350GF4/B4/A4	100	-	-	-	-	300	-	-	500	-	-	-	-
MR-J4-500GF4/B4/A4	130 <sup>(Note 3)</sup>	-	-	-	-	-	300	-	-	500	-	-	-
MR-J4-700GF4/B4/A4	170 <sup>(Note 3)</sup>	-	-	-	-	-	-	300	-	-	500	-	-
MR-J4-11KGF/B4/A4	-	500 (800)	-	-	-	-	-	-	-	-	-	500 (800)	-
MR-J4-15KGF/B4/A4	-	-	850 (1300)	-	-	-	-	-	-	-	-	-	850 (1300)
MR-J4-22KGF/B4/A4	-	-	850 (1300)	-	-	-	-	-	-	-	-	-	850 (1300)

Resistance regeneration converter unit model	Drive unit model	Permissible regenerative power [W] of regenerative option <sup>(Note 4)</sup>	
		MR-RB137-4	MR-RB13V-4
		4 Ω	4 Ω <sup>(Note 5)</sup>
MR-CR55K4	MR-J4-DU30KB4/A4 MR-J4-DU37KB4/A4 MR-J4-DU45KB4/A4 MR-J4-DU55KB4/A4	1300	3900

- Notes: 1. Be sure to cool the unit forcibly with a cooling fan (92 mm × 92 mm, minimum air flow: 1.0 m<sup>3</sup>/min). The cooling fan must be prepared by user.  
2. The value in brackets is applicable when cooling fans (two units of 92 mm × 92 mm, minimum air flow: 1.0 m<sup>3</sup>/min) are installed, and then [Pr. PA02] is changed.  
3. The servo amplifier built-in regenerative resistor supports the maximum torque deceleration when the servo motor is used within the rated speed and the recommended load to motor inertia ratio. Contact your local sales office if the operating motor speed or the load to motor inertia ratio exceeds the rated speed or the recommended ratio.  
4. The power values in this table are resistor-generated powers, not rated powers.  
5. This is the resultant resistance when three units of MR-RB13V-4 are connected in parallel.  
6. The regenerative resistor enclosed with the servo amplifiers 11 kW to 22 kW does not have a protective cover, and touching the resistor (including the wiring screws) may cause a burn or an electric shock. Provide safety measures such as a protective cover or use MR-RB\_ regenerative option.

## \* Precautions when mounting/connecting the regenerative option

- The regenerative option causes a temperature rise of 100 °C or higher relative to the ambient temperature. Fully examine heat dissipation, installation position, wires used before installing the unit. Use flame-retardant wires or apply flame retardant on wires, and keep the wires clear of the unit.
- Use twisted wires for connecting the regenerative option to the servo amplifier, and keep the wire length to a maximum of 5 m.
- Use twisted wires for connecting a thermal sensor, and make sure that the sensor does not fail to work properly due to inducted noise.
- There are restrictions on the mounting direction of the regenerative option. Refer to relevant Servo Amplifier Instruction Manual for details.

## Regenerative Option

GF

GF-RJ

B

B-RJ

WB

A

A-RJ

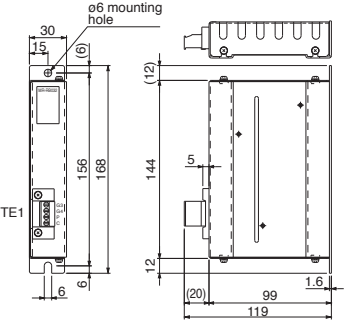
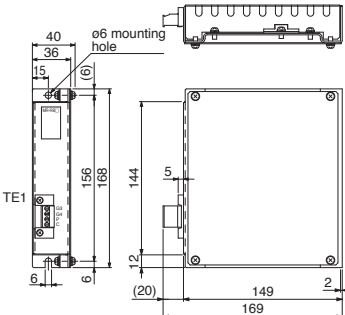
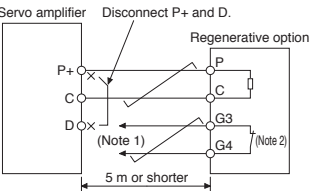
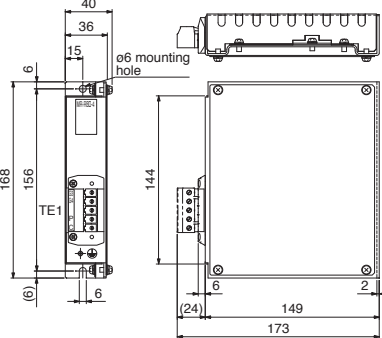
Dimensions	Connections										
<p>MR-RB032 (for 200 V/100 V)</p>  <p>Terminal arrangement</p> <table border="1" data-bbox="874 436 906 548"> <tr><td>TE1</td></tr> <tr><td>G3</td></tr> <tr><td>G4</td></tr> <tr><td>P</td></tr> <tr><td>C</td></tr> </table> <p>Applicable wire size (Note 3): 0.2 mm<sup>2</sup> to 2.5 mm<sup>2</sup> (AWG 24 to 12) Mounting screw size: M5</p> <table border="1" data-bbox="810 627 1007 672"> <thead> <tr> <th>Model</th> <th>Mass [kg]</th> </tr> </thead> <tbody> <tr> <td>MR-RB032</td> <td>0.5</td> </tr> </tbody> </table>	TE1	G3	G4	P	C	Model	Mass [kg]	MR-RB032	0.5		
TE1											
G3											
G4											
P											
C											
Model	Mass [kg]										
MR-RB032	0.5										
<p>MR-RB12 (for 200 V/100 V), MR-RB14 (for 200 V)</p>  <p>Terminal arrangement</p> <table border="1" data-bbox="874 795 906 907"> <tr><td>TE1</td></tr> <tr><td>G3</td></tr> <tr><td>G4</td></tr> <tr><td>P</td></tr> <tr><td>C</td></tr> </table> <p>Applicable wire size (Note 3): 0.2 mm<sup>2</sup> to 2.5 mm<sup>2</sup> (AWG 24 to 12) Mounting screw size: M5</p> <table border="1" data-bbox="810 981 1007 1048"> <thead> <tr> <th>Model</th> <th>Mass [kg]</th> </tr> </thead> <tbody> <tr> <td>MR-RB12</td> <td rowspan="2">1.1</td> </tr> <tr> <td>MR-RB14</td> </tr> </tbody> </table>	TE1	G3	G4	P	C	Model	Mass [kg]	MR-RB12	1.1	MR-RB14	
TE1											
G3											
G4											
P											
C											
Model	Mass [kg]										
MR-RB12	1.1										
MR-RB14											
<p>MR-RB1H-4 (for 400 V)</p>  <p>Terminal arrangement</p> <table border="1" data-bbox="874 1176 906 1321"> <tr><td>TE1</td></tr> <tr><td>G3</td></tr> <tr><td>G4</td></tr> <tr><td>P</td></tr> <tr><td>C</td></tr> </table> <p>Applicable wire size (Note 3): 0.2 mm<sup>2</sup> to 4.0 mm<sup>2</sup> (AWG 24 to 10) Mounting screw size: M5</p> <table border="1" data-bbox="810 1411 1007 1456"> <thead> <tr> <th>Model</th> <th>Mass [kg]</th> </tr> </thead> <tbody> <tr> <td>MR-RB1H-4</td> <td>1.1</td> </tr> </tbody> </table>	TE1	G3	G4	P	C	Model	Mass [kg]	MR-RB1H-4	1.1		
TE1											
G3											
G4											
P											
C											
Model	Mass [kg]										
MR-RB1H-4	1.1										

Notes: 1. Create a sequence circuit that turns off the magnetic contactor when abnormal overheating occurs.

2. G3 and G4 terminals are thermal sensor. G3-G4 opens when the regenerative option overheats abnormally.

3. The wire size shows wiring specification of the connector. Refer to "Wires, Molded-Case Circuit Breakers and Magnetic Contactors" in this catalog for examples of wire size selection.

Servo Amplifiers

Rotary Servo Motors

Linear Servo Motors

Direct Drive Motors

Options/Peripheral Equipment

LV/WS/Wires

Product List

Precautions

## Regenerative Option

**GF GF-RJ B B-RJ WB A A-RJ**

Dimensions	[Unit: mm]	Connections																				
<p>MR-RB30, MR-RB3N, MR-RB31, MR-RB32, MR-RB34 (for 200 V) MR-RB3M-4, MR-RB3G-4, MR-RB34-4, MR-RB3U-4 (for 400 V)</p> <table border="1" style="margin-top: 10px;"> <thead> <tr> <th rowspan="2">Model</th> <th colspan="2">Variable dimensions</th> <th rowspan="2">Mass [kg]</th> </tr> <tr> <th>A</th> <th>B</th> </tr> </thead> <tbody> <tr><td>MR-RB30</td><td rowspan="4">17</td><td rowspan="4">335</td><td rowspan="4">2.9</td></tr> <tr><td>MR-RB3N</td></tr> <tr><td>MR-RB31</td></tr> <tr><td>MR-RB32</td></tr> <tr><td>MR-RB34</td><td rowspan="4">23</td><td rowspan="4">341</td><td rowspan="4">2.9</td></tr> <tr><td>MR-RB3M-4</td></tr> <tr><td>MR-RB3G-4</td></tr> <tr><td>MR-RB34-4</td></tr> <tr><td>MR-RB3U-4</td></tr> </tbody> </table>	Model	Variable dimensions		Mass [kg]	A	B	MR-RB30	17	335	2.9	MR-RB3N	MR-RB31	MR-RB32	MR-RB34	23	341	2.9	MR-RB3M-4	MR-RB3G-4	MR-RB34-4	MR-RB3U-4	<p>For MR-J4-500GF/B/A or smaller, MR-J4-350GF4/B4/A4 or smaller, and MR-J4W_-B</p>
Model		Variable dimensions			Mass [kg]																	
	A	B																				
MR-RB30	17	335	2.9																			
MR-RB3N																						
MR-RB31																						
MR-RB32																						
MR-RB34	23	341	2.9																			
MR-RB3M-4																						
MR-RB3G-4																						
MR-RB34-4																						
MR-RB3U-4																						
<p>MR-RB50, MR-RB5N, MR-RB51 (for 200 V) MR-RB5G-4, MR-RB54-4, MR-RB5U-4 (for 400 V)</p> <table border="1" style="margin-top: 10px;"> <thead> <tr> <th rowspan="2">Model</th> <th colspan="2">Variable dimensions</th> <th rowspan="2">Mass [kg]</th> </tr> <tr> <th>A</th> <th>B</th> </tr> </thead> <tbody> <tr><td>MR-RB50</td><td rowspan="4">17</td><td rowspan="4">217</td><td rowspan="4">5.6</td></tr> <tr><td>MR-RB5N</td></tr> <tr><td>MR-RB51</td></tr> <tr><td>MR-RB5G-4</td></tr> <tr><td>MR-RB54-4</td><td rowspan="2">23</td><td rowspan="2">223</td><td rowspan="2">5.6</td></tr> <tr><td>MR-RB5U-4</td></tr> </tbody> </table>	Model	Variable dimensions		Mass [kg]	A	B	MR-RB50	17	217	5.6	MR-RB5N	MR-RB51	MR-RB5G-4	MR-RB54-4	23	223	5.6	MR-RB5U-4	<p>For MR-J4-500GF4/B4/A4 and MR-J4-700GF(4)/B(4)/A(4)</p>			
Model		Variable dimensions			Mass [kg]																	
	A	B																				
MR-RB50	17	217	5.6																			
MR-RB5N																						
MR-RB51																						
MR-RB5G-4																						
MR-RB54-4	23	223	5.6																			
MR-RB5U-4																						

- Notes:
1. Create a sequence circuit that turns off the magnetic contactor when abnormal overheating occurs.
  2. When using MR-RB3M-4, MR-RB3G-4, MR-RB34-4, MR-RB3U-4, MR-RB50, MR-RB5N, MR-RB51, MR-RB5G-4, MR-RB54-4, or MR-RB5U-4, cool the unit forcibly with a cooling fan (92 mm x 92 mm, minimum air flow: 1.0 m<sup>3</sup>/min). The cooling fan must be prepared by user.
  3. When MR-RB30, MR-RB3N, MR-RB31, MR-RB32, or MR-RB34 is used, it may be necessary to cool the unit forcibly with a cooling fan (92 mm x 92 mm, minimum air flow: 1.0 m<sup>3</sup>/min), depending on the operating environment. Refer to relevant Servo Amplifier Instruction Manual for details. The cooling fan must be prepared by user.
  4. G3 and G4 terminals are thermal sensor. G3-G4 opens when the regenerative option overheats abnormally.

Regenerative Option

GF GF-RJ B B-RJ A A-RJ

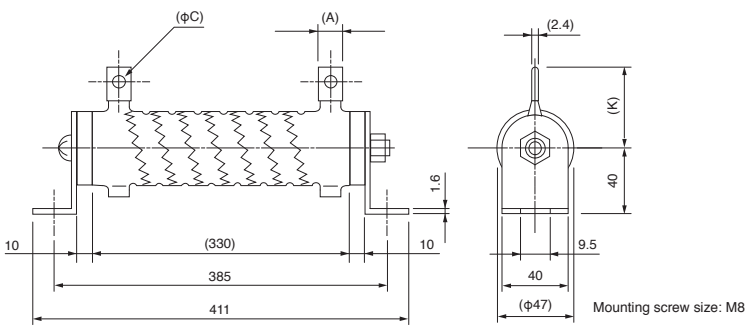
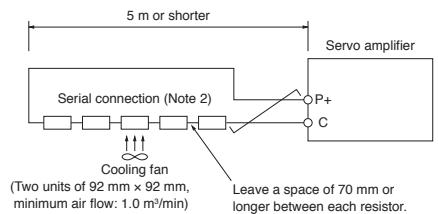
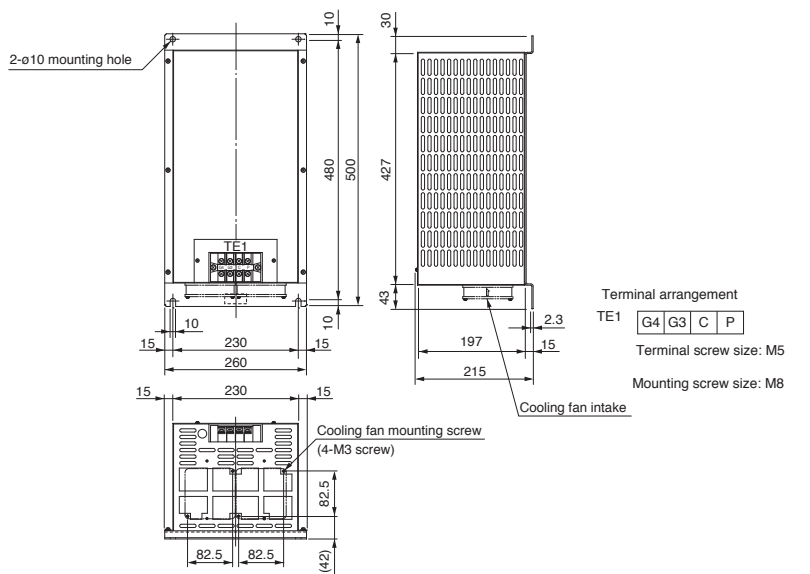
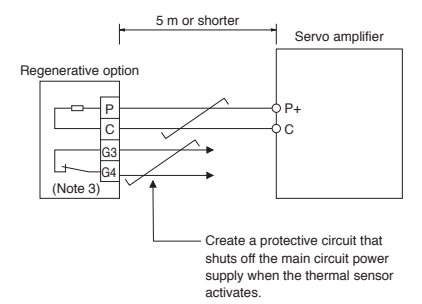
Dimensions	[Unit: mm]	Connections																																																					
<p>Standard accessory (Note 1)                      GRZG400-0.8Ω, GRZG400-0.6Ω, GRZG400-0.5Ω (for 200 V)                      GRZG400-2.5Ω, GRZG400-2Ω (for 400 V)</p> 																																																							
																																																							
<table border="1" style="width:100%; border-collapse: collapse;"> <thead> <tr> <th rowspan="2">Model</th> <th rowspan="2">Qty.</th> <th rowspan="2">Permissible regenerative power [W]</th> <th rowspan="2">With cooling fan [W]</th> <th rowspan="2">Resistance value [Ω]</th> <th colspan="3">Variable dimensions</th> <th rowspan="2">Mass/unit [kg]</th> </tr> <tr> <th>A</th> <th>C</th> <th>K</th> </tr> </thead> <tbody> <tr> <td>GRZG400-0.8Ω</td> <td>4</td> <td>500</td> <td>800</td> <td>3.2 (0.8 Ω × 4)</td> <td>10</td> <td>5.5</td> <td>39</td> <td rowspan="5" style="text-align: center; vertical-align: middle;">0.8</td> </tr> <tr> <td>GRZG400-0.6Ω</td> <td>5</td> <td>850</td> <td>1300</td> <td>3 (0.6 Ω × 5)</td> <td>16</td> <td>8.2</td> <td>46</td> </tr> <tr> <td>GRZG400-0.5Ω</td> <td>5</td> <td>850</td> <td>1300</td> <td>2.5 (0.5 Ω × 5)</td> <td></td> <td></td> <td></td> </tr> <tr> <td>GRZG400-2.5Ω</td> <td>4</td> <td>500</td> <td>800</td> <td>10 (2.5 Ω × 4)</td> <td>10</td> <td>5.5</td> <td>39</td> </tr> <tr> <td>GRZG400-2Ω</td> <td>5</td> <td>850</td> <td>1300</td> <td>10 (2 Ω × 5)</td> <td></td> <td></td> <td></td> </tr> </tbody> </table>			Model	Qty.	Permissible regenerative power [W]	With cooling fan [W]	Resistance value [Ω]	Variable dimensions			Mass/unit [kg]	A	C	K	GRZG400-0.8Ω	4	500	800	3.2 (0.8 Ω × 4)	10	5.5	39	0.8	GRZG400-0.6Ω	5	850	1300	3 (0.6 Ω × 5)	16	8.2	46	GRZG400-0.5Ω	5	850	1300	2.5 (0.5 Ω × 5)				GRZG400-2.5Ω	4	500	800	10 (2.5 Ω × 4)	10	5.5	39	GRZG400-2Ω	5	850	1300	10 (2 Ω × 5)			
Model	Qty.	Permissible regenerative power [W]						With cooling fan [W]	Resistance value [Ω]	Variable dimensions			Mass/unit [kg]																																										
			A	C	K																																																		
GRZG400-0.8Ω	4	500	800	3.2 (0.8 Ω × 4)	10	5.5	39	0.8																																															
GRZG400-0.6Ω	5	850	1300	3 (0.6 Ω × 5)	16	8.2	46																																																
GRZG400-0.5Ω	5	850	1300	2.5 (0.5 Ω × 5)																																																			
GRZG400-2.5Ω	4	500	800	10 (2.5 Ω × 4)	10	5.5	39																																																
GRZG400-2Ω	5	850	1300	10 (2 Ω × 5)																																																			
<p>MR-RB5R, MR-RB9F, MR-RB9T (for 200 V) (Note 1)                      MR-RB5K-4, MR-RB6K-4 (for 400 V) (Note 1)</p>  <p>Terminal arrangement                      TE1 G4 G3 C P                      Terminal screw size: M5                      Mounting screw size: M8</p>																																																							
																																																							
<table border="1" style="width:100%; border-collapse: collapse;"> <thead> <tr> <th>Model</th> <th>Permissible regenerative power [W]</th> <th>With cooling fan [W]</th> <th>Description</th> <th>Mass [kg]</th> </tr> </thead> <tbody> <tr> <td>MR-RB5R</td> <td>500</td> <td>800</td> <td>GRZG400-0.8Ω × 4</td> <td>10</td> </tr> <tr> <td>MR-RB9F</td> <td>850</td> <td>1300</td> <td>GRZG400-0.6Ω × 5</td> <td>11</td> </tr> <tr> <td>MR-RB9T</td> <td>850</td> <td>1300</td> <td>GRZG400-0.5Ω × 5</td> <td>11</td> </tr> <tr> <td>MR-RB5K-4</td> <td>500</td> <td>800</td> <td>GRZG400-2.5Ω × 4</td> <td>10</td> </tr> <tr> <td>MR-RB6K-4</td> <td>850</td> <td>1300</td> <td>GRZG400-2Ω × 5</td> <td>11</td> </tr> </tbody> </table>			Model	Permissible regenerative power [W]	With cooling fan [W]	Description	Mass [kg]	MR-RB5R	500	800	GRZG400-0.8Ω × 4	10	MR-RB9F	850	1300	GRZG400-0.6Ω × 5	11	MR-RB9T	850	1300	GRZG400-0.5Ω × 5	11	MR-RB5K-4	500	800	GRZG400-2.5Ω × 4	10	MR-RB6K-4	850	1300	GRZG400-2Ω × 5	11																							
Model	Permissible regenerative power [W]	With cooling fan [W]	Description	Mass [kg]																																																			
MR-RB5R	500	800	GRZG400-0.8Ω × 4	10																																																			
MR-RB9F	850	1300	GRZG400-0.6Ω × 5	11																																																			
MR-RB9T	850	1300	GRZG400-0.5Ω × 5	11																																																			
MR-RB5K-4	500	800	GRZG400-2.5Ω × 4	10																																																			
MR-RB6K-4	850	1300	GRZG400-2Ω × 5	11																																																			

- Notes: 1. To increase the regenerative braking frequency, install cooling fans (two units of 92 mm × 92 mm, minimum air flow: 1.0 m<sup>3</sup>/min), and then change [Pr. PA02]. The cooling fans must be prepared by user.  
 2. By installing a thermal sensor, create a safety circuit that shuts off the main circuit power supply when abnormal overheating occurs.  
 3. G3 and G4 terminals are thermal sensor. G3-G4 opens when the regenerative option overheats abnormally.

## Regenerative Option

**B B-RJ A A-RJ**

Dimensions [Unit: mm]	Connections															
<p>MR-RB139, MR-RB137 (for 200 V) MR-RB137-4, MR-RB13V-4 (for 400 V)</p> <p style="text-align: center;">Cooling fan intake</p> <div style="display: flex; justify-content: space-around;"> <div style="text-align: center;"> <p>Terminal arrangement (for 200 V) TE1 R1 S1 G4 G3 C P Terminal screw size: M5</p> </div> <div style="text-align: center;"> <p>Terminal arrangement (for 400 V) TE1 R400 S400 G4 G3 C P Terminal screw size: M5</p> </div> </div> <p style="text-align: center;">Mounting screw size: M8</p> <table border="1" style="width: 100%; border-collapse: collapse; margin-top: 10px;"> <thead> <tr> <th>Model</th> <th>Permissible regenerative power [W]</th> <th>Mass [kg]</th> </tr> </thead> <tbody> <tr> <td>MR-RB139</td> <td>1300</td> <td>10</td> </tr> <tr> <td>MR-RB137</td> <td>3900 (Three units are required.) (Note 2)</td> <td>11</td> </tr> <tr> <td>MR-RB137-4</td> <td>1300</td> <td>10</td> </tr> <tr> <td>MR-RB13V-4</td> <td>3900 (Three units are required.) (Note 2)</td> <td>11</td> </tr> </tbody> </table>	Model	Permissible regenerative power [W]	Mass [kg]	MR-RB139	1300	10	MR-RB137	3900 (Three units are required.) (Note 2)	11	MR-RB137-4	1300	10	MR-RB13V-4	3900 (Three units are required.) (Note 2)	11	<p>MR-RB139, MR-RB137-4</p> <p>Create an external sequence circuit which opens the contact of the resistance regeneration converter unit main circuit contactor when overheating causes the thermal sensor contact (normally closed) in the regenerative option open.</p> <hr/> <p>MR-RB137, MR-RB13V-4</p> <p>Create an external sequence circuit which opens the contact of the resistance regeneration converter unit main circuit contactor when overheating causes the thermal sensor contact (normally closed) in the regenerative option open.</p>
Model	Permissible regenerative power [W]	Mass [kg]														
MR-RB139	1300	10														
MR-RB137	3900 (Three units are required.) (Note 2)	11														
MR-RB137-4	1300	10														
MR-RB13V-4	3900 (Three units are required.) (Note 2)	11														

- Notes: 1. One unit of cooling fan is attached for MR-RB137-4 and MR-RB13V-4.  
 2. Three units of MR-RB137 or MR-RB13V-4 are required per resistance regeneration converter unit.  
 3. Connect the regenerative option to the resistance regeneration converter unit, and keep the total length of the wiring within 5 m.  
 4. Disconnect a short-circuit bar between P1 and P2 when using the power factor improving DC reactor.

**Multifunction Regeneration Converter (FR-XC, FR-XC-H) (Note 5)**
**GF GF-RJ B B-RJ A A-RJ**

FR-XC multifunction regeneration converter is suitable for 200 V class servo amplifiers ranged from 100 W to 22 kW, and FR-XC-H for 400 V class servo amplifiers ranged from 600 W to 22 kW. The multifunction regeneration converter is not compatible with multi-axis servo amplifiers.

Use the common bus regeneration mode with the harmonic suppression function disabled. The power regeneration mode is not supported.

**200 V class**

Multifunction regeneration converter	FR-XC-	7.5K	11K	15K	22K	30K	37K	55K
Capacity	[kW]	7.5	11	15	22	30	37	55
Maximum number of connectable servo amplifiers		10						
Total capacity of connectable servo amplifiers (Note 1)	[kW]	3.5 (5.5)	5.5 (7.5)	7.5 (11)	22	30	37	55
Continuous output (Note 1)	[kW]	3.5 (5.5)	5.5 (7.5)	7.5 (11)	18.5	22	30	45
Rated input current [A]	Power driving	33	47	63	92	124	151	223
	Regenerative driving	26	37	51	74	102	125	186
Overload current rating		100% continuous / 150% 60 s						
Power source	Rated input AC voltage/frequency	Three-phase 200 to 240 V AC, 50/60 Hz						
	Permissible AC voltage fluctuation	Three-phase 170 to 264 V AC, 50/60 Hz						
	Permissible frequency fluctuation	±5%						
	Power supply capacity [kVA]	17	20	28	41	52	66	100
IP rating (IEC 60529)		Open type (IP00)						
Cooling system		Forced air						
Environment	Surrounding air temperature	-10 °C to 50 °C (non-freezing)						
	Surrounding air humidity	90 %RH or less (non-condensing)						
	Storage temperature	-20 °C to 65 °C						
	Atmosphere	Indoors (without corrosive gas, flammable gas, oil mist, dust and dirt)						
	Altitude	2500 m or less (For the installation at an altitude above 1000 m, consider a 3% reduction in the rated current per 500 m increase in altitude.)						
Vibration resistance		5.9 m/s <sup>2</sup> at 10 Hz to 55 Hz (directions of X, Y, Z axes)						
Molded-case circuit breaker or earth-leakage current breaker (Note 4)		100AF 60A (30AF 30A)	100AF 75A (50AF 50A)	225AF 125A (100AF 75A)	225AF 175A (100AF 100A)	225AF 225A (125AF 125A)	400AF 250A (125AF 125A)	400AF 400A (225AF 175A)
Magnetic contactor (Note 4)		S-T35 (S-T21)	S-T50 (S-T35)	S-T65 (S-T50)	S-T100 (S-T65)	S-N125 (S-T80)	S-N150 (S-T100)	S-N220 (S-N125)

**400 V class**

Multifunction regeneration converter	FR-XC-H	7.5K	11K	15K	22K	30K	37K	55K
Capacity	[kW]	7.5	11	15	22	30	37	55
Maximum number of connectable servo amplifiers		10						
Total capacity of connectable servo amplifiers (Note 1)	[kW]	3.5 (5.5)	5.5 (7.5)	7.5 (11)	22	30	37	55
Continuous output (Note 1)	[kW]	3.5 (5.5)	5.5 (7.5)	7.5 (11)	18.5	22	30	45
Rated input current [A]	Power driving	18	25	34	49	65	80	118
	Regenerative driving	14	20	27	39	54	66	98
Overload current rating		100% continuous / 150% 60 s						
Power source	Rated input AC voltage/frequency (Note 2)	Three-phase 380 to 500 V AC, 50/60 Hz						
	Permissible AC voltage fluctuation (Note 3)	Three-phase 323 to 550 V AC, 50/60 Hz						
	Permissible frequency fluctuation	±5%						
	Power supply capacity [kVA]	17	20	28	41	52	66	100
IP rating (IEC 60529)		Open type (IP00)						
Cooling system		Forced air						
Environment	Surrounding air temperature	-10 °C to 50 °C (non-freezing)						
	Surrounding air humidity	90 %RH or less (non-condensing)						
	Storage temperature	-20 °C to 65 °C						
	Atmosphere	Indoors (without corrosive gas, flammable gas, oil mist, dust and dirt)						
	Altitude	2500 m or less (For the installation at an altitude above 1000 m, consider a 3% reduction in the rated current per 500 m increase in altitude.)						
Vibration resistance		5.9 m/s <sup>2</sup> at 10 Hz to 55 Hz (directions of X, Y, Z axes)						
Molded-case circuit breaker or earth-leakage current breaker (Note 4)		30AF 30A (30AF 15A)	50AF 50A (30AF 20A)	100AF 60A (30AF 30A)	100AF 100A (50AF 50A)	225AF 125A (60AF 60A)	225AF 150A (100AF 75A)	225AF 200A (100AF 100A)
Magnetic contactor (Note 4)		S-T21	S-T25 (S-T21)	S-T35 (S-T21)	S-T50 (S-T25)	S-T65 (S-T35)	S-T80 (S-T50)	S-N125 (S-T65)

Notes: 1. The values in brackets are applicable when the number of connected servo amplifiers is six or less.

2. When connecting to a servo amplifier, use with a voltage range of 380 V to 480 V.

3. When connecting to a servo amplifier, use with a voltage range of 323 V to 528 V.

4. The models in brackets are applicable when the capacity [kW] of FR-XC(H) ≥ Total rated capacity [kW] of servo amplifiers connected to FR-XC(H) × 2

5. The following are specifications at the time of August 2023.

For selecting an FR-XC multifunction regeneration converter, refer to the latest "FR-XC Instruction Manual" and relevant Servo Amplifier Instruction Manual.

**\* Precautions when selecting the multifunction regeneration converter**

- Total rated capacity [kW] of servo amplifiers connected to FR-XC(H) ≤ Capacity [kW] of FR-XC(H)
- Effective value [kW] of total output power of servo motors ≤ Continuous output [kW] of FR-XC(H)
- Maximum value [kW] of total output power of servo motors ≤ FR-XC(H) capacity [kW] × 1.5

## Multifunction Regeneration Converter (FR-XC, FR-XC-H)

GF GF-RJ B B-RJ A A-RJ

### Connection example

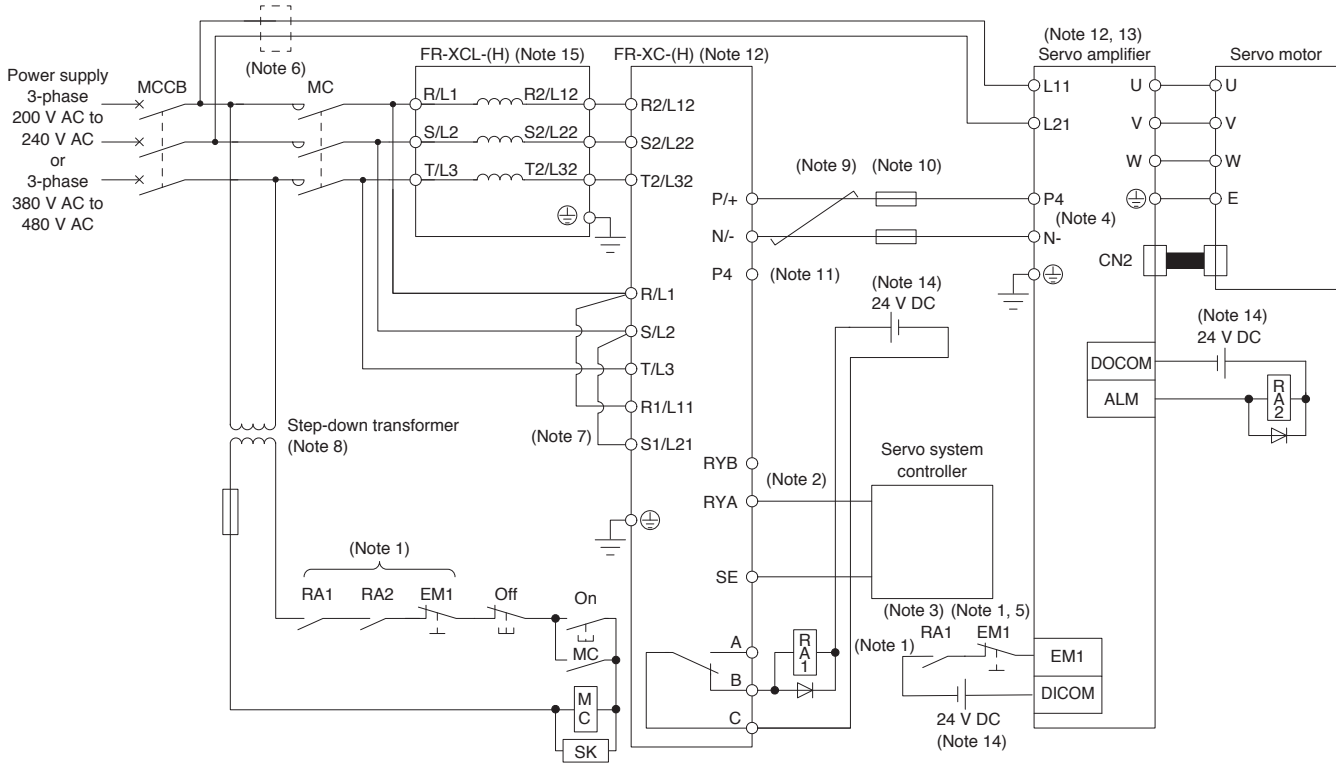

Notes: 1. Create a sequence that shuts off the main circuit power when either:

An alarm occurs on FR-XC-(H) or the servo amplifier, or EM1 (Forced stop 1) is validated.

2. For the servo amplifier, create a sequence that switches the servo-on after FR-XC-(H) is ready.

3. Create a sequence that stops the servo motor with the emergency stop input to the servo system controller when an alarm occurs on FR-XC-(H). When the emergency stop input is not available in the servo system controller, stop the servo motor with the forced stop input to the servo amplifier as shown in the diagram.

4. Disconnect the short-circuit bar between P3 and P4 when using FR-XC-(H).

5. Set [Pr. PA04] to "0 0 \_\_" to enable EM1 (Forced stop 1).

6. When wires used for L11 and L21 are thinner than those for L1, L2, and L3, use a molded-case circuit breaker.

7. When using a separate power supply for the control circuit, remove the short-circuit bars between R/L1 and R1/L11, and S/L2 and S1/L21.

8. When FR-XC-H is used, a step-down transformer is required if coil voltage of the magnetic contactor is in 200 V class.

9. Use twisted wires for connecting the DC power supply between FR-XC-(H) and the servo amplifiers, and keep the wire length to a maximum of 5 m (3 m or less for EMC compliance).

10. Install a fuse between each FR-XC-(H) and servo amplifier.

11. Do not connect anything to the P4 terminal of FR-XC-(H).

12. Inputs/outputs (main circuit) of FR-XC-(H) and the servo amplifier include high frequency components, and they may interfere with peripheral communication devices.

In this case, the interference can be reduced with the installation of a radio noise filter (FR-BIF or FR-BIF-H) or line noise filter (FR-BSF01 or FR-BLF).

13. When using 7 kW or smaller servo amplifiers, wire a built-in regenerative resistor.

14. For convenience of illustration, the diagram shows separate 24 V DC power supplies for input and output signals. However, the input and output signals can share a common power supply.

15. When using FR-XC-(H), be sure to use the following dedicated stand-alone reactor (FR-XCL or FR-XCL-H). Do not use a power factor improving AC reactor (FR-HAL or FR-HAL-H) or a power factor improving DC reactor (FR-HEL or FR-HEL-H) with FR-XC-(H).

Multifunction regeneration converter	Dedicated stand-alone reactor
FR-XC-7.5K	FR-XCL-7.5K
FR-XC-11K	FR-XCL-11K
FR-XC-15K	FR-XCL-15K
FR-XC-22K	FR-XCL-22K
FR-XC-30K	FR-XCL-30K
FR-XC-37K	FR-XCL-37K
FR-XC-55K	FR-XCL-55K

Multifunction regeneration converter	Dedicated stand-alone reactor
FR-XC-H7.5K	FR-XCL-H7.5K
FR-XC-H11K	FR-XCL-H11K
FR-XC-H15K	FR-XCL-H15K
FR-XC-H22K	FR-XCL-H22K
FR-XC-H30K	FR-XCL-H30K
FR-XC-H37K	FR-XCL-H37K
FR-XC-H55K	FR-XCL-H55K



**Dynamic Brake**

**GF GF-RJ B B-RJ B-RJ100 A A-RJ**

Use the following external dynamic brake (option) with the 9 kW or larger servo amplifiers.

Without the external dynamic brake, a servo motor does not stop immediately at emergency stop and falls in free-run status, causing an accident such as machine collision, etc. Take measures to ensure safety on the entire system when not using the dynamic brake.

Servo amplifier/ drive unit model	Dynamic brake model	Fig.
MR-J4-DU900B	DBU-7K-R6 DBU-11K (Note 1)	A
MR-J4-11KGF/B/A MR-J4-DU11KB	DBU-11K	
MR-J4-15KGF/B/A MR-J4-DU15KB	DBU-15K	
MR-J4-22KGF/B/A MR-J4-DU22KB	DBU-22K-R1	

Servo amplifier/ drive unit model	Dynamic brake model	Fig.
MR-J4-DU900B4	DBU-7K-4-2R0 DBU-11K-4 (Note 2)	B
MR-J4-11KGF4/B4/A4 MR-J4-DU11KB4	DBU-11K-4	
MR-J4-15KGF4/B4/A4 MR-J4-DU15KB4 MR-J4-22KGF4/B4/A4 MR-J4-DU22KB4	DBU-22K-4	
MR-J4-DU30KB/A MR-J4-DU37KB/A	DBU-37K-R1	C
MR-J4-DU30KB4/A4 MR-J4-DU37KB4/A4 MR-J4-DU45KB4/A4 MR-J4-DU55KB4/A4	DBU-55K-4-R5	
MR-J4-DU45KB4-RJ100 MR-J4-DU55KB4-RJ100	DBU-P55K-4-B	

Notes: 1. Use this dynamic brake when HG-JR801 or HG-JR903 servo motor is used.  
2. Use this dynamic brake when HG-JR8014 or HG-JR9034 servo motor is used.

**Dimensions** [Unit: mm]

**A**

Terminal arrangement  
Screw size: M3.5  
Screw size: M4

Model	A	B	C	D	E	F	G	Mass [kg]	Wire size [mm <sup>2</sup> ] (Note 1)	
									U, V, W	Other than U, V, and W
DBU-7K-R6	200	190	140	20	5	170	163.5	2	3.5 (AWG 12)	2 (AWG 14)
DBU-11K									5.5 (AWG 10)	
DBU-15K DBU-22K-R1	250	238	150	25	6	235	228	6		

**B**

TE1  
Screw size: M3.5  
TE2  
Screw size: M4  
Mounting screw size: M6

Model	Mass [kg]	Wire size [mm <sup>2</sup> ] (Note 1)	
		U, V, W	Other than U, V, and W
DBU-7K-4-2R0	6.7	3.5 (AWG 12)	2 (AWG 14)
DBU-11K-4		5.5 (AWG 10)	
DBU-22K-4			

Notes: 1. The wire size is applicable when 600 V grade heat-resistant polyvinyl chloride insulated wire (HIV wires) is used.

Servo Amplifiers

Rotary Servo Motors

Linear Servo Motors

Direct Drive Motors

Options/Peripheral Equipment

LVS/Wires

Product List

Precautions

## Dynamic Brake

**B B-RJ B-RJ100 A A-RJ**

Dimensions [Unit: mm]

**C**

TE1  
Screw size: M5

TE2  
Screw size: M3.5

Mounting screw size: M8

Model	Mass [kg]	Wire size [mm <sup>2</sup> ] <small>(Note 1)</small>	
		U, V, W	Other than U, V, and W
DBU-37K-R1	8	14	2
DBU-55K-4-R5	11	(AWG 6)	(AWG 14)

**D**

TE1  
Terminal screw size: M3.5

TE2  
Terminal screw size: M5

Mounting screw size: M8

Model	Mass [kg]	Wire size [mm <sup>2</sup> ] <small>(Note 1)</small>	
		U, V, W	Other than U, V, and W
DBU-P55K-4-B	25	14 (AWG 6)	2 (AWG 14)

Notes: 1. The wire size is applicable when 600 V grade heat-resistant polyvinyl chloride insulated wire (HIV wires) is used.

## Dynamic Brake

GF GF-RJ B B-RJ A A-RJ

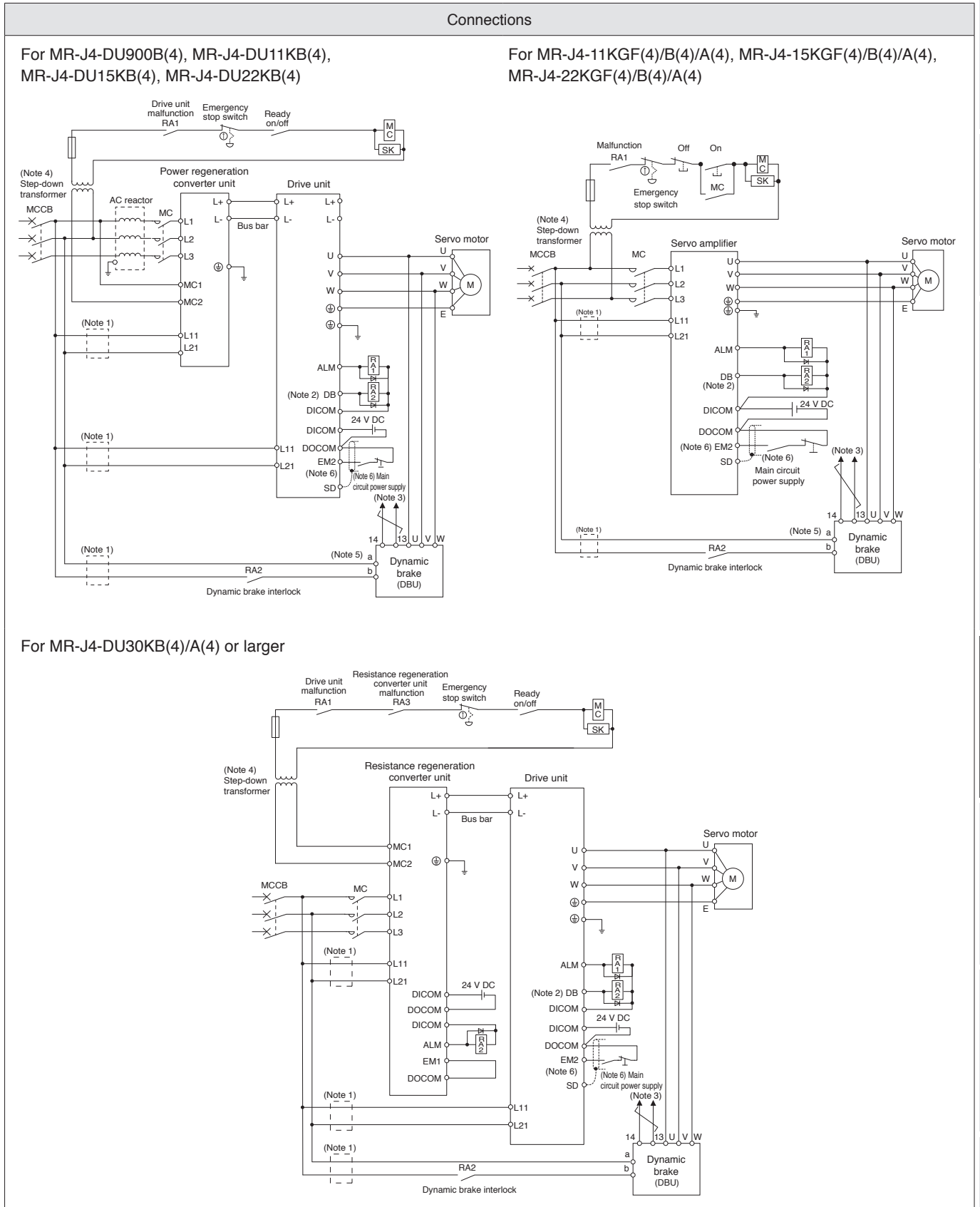

- Notes: 1. Install an overcurrent protection device (molded-case circuit breaker, fuse, etc.) to protect the branch circuit.  
 2. Assign DB (Dynamic brake interlock) with [Pr. PD07] to [Pr. PD09] for MR-J4-B/MR-J4-B4/MR-J4-DU\_B/MR-J4-DU\_B4.  
 3. The terminals 13 and 14 are normally opened outputs. If the dynamic brake is welded, the terminals 13 and 14 will be opened. Thus, create an external sequence circuit so that SON (Servo-on) does not turn on when the terminals 13 and 14 are opened.  
 4. A step-down transformer is required if the servo amplifier, power regeneration converter unit, or resistance regeneration converter unit is in 400 V class, and coil voltage of the magnetic contactor is in 200 V class.  
 5. When using DBU-7K-4-2R0, DBU-11K-4 or DBU-22K-4, the power supply voltage must be between 1-phase 380 V AC and 463 V AC, 50 Hz/60 Hz. Refer to relevant Servo Amplifier Instruction Manual for details.  
 6. To prevent an unexpected restart of the servo amplifier, create a circuit to turn off EM2 (Forced stop 2) when the main circuit power is turned off.

Dynamic Brake

B-RJ100

Connections

For MR-J4-DU\_B4-RJ100

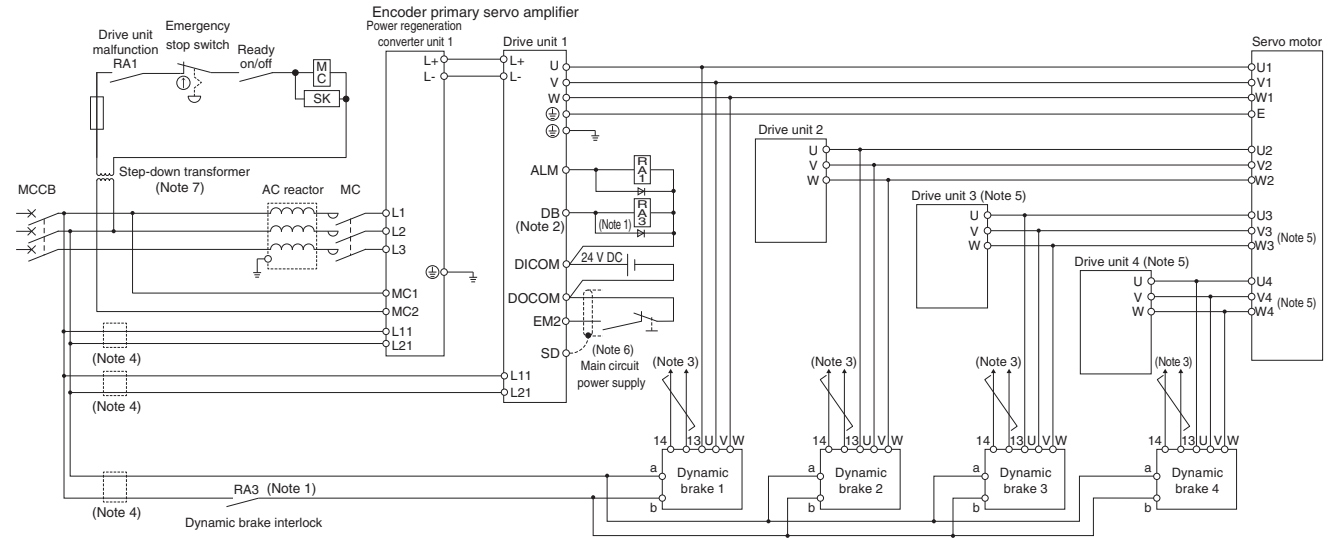

- Notes:
1. The dynamic brake must be controlled by the drive unit of the encoder primary servo amplifier.
  2. Assign DB (Dynamic brake interlock) with [Pr. PD07] to [Pr. PD09].
  3. The terminals 13 and 14 are normally opened outputs. If the dynamic brake is welded, the terminals 13 and 14 will be opened. Thus, create an external sequence circuit so that SON (Servo-on) does not turn on when the terminals 13 and 14 are opened.
  4. Install an overcurrent protection device (molded-case circuit breaker, fuse, etc.) to protect the branch circuit. Refer to "MR-CV\_MR-CR55K\_MR-J4-DU\_B\_(-RJ) MR-J4-DU\_A\_(-RJ) Instruction Manual" for details.
  5. This diagram is applicable when HG-JR150K24W0C, HG-JR180K24W0C, HG-JR200K24W0C, or HG-JR220K24W0C servo motor is used. For HG-JR110K24W0C, connections to drive unit 3 and 4 are not required.
  6. To prevent an unexpected restart of the drive unit, create a circuit to turn off EM2 (Forced stop 2) when the main circuit power is turned off.
  7. A step-down transformer is required if coil voltage of the magnetic contactor is in 200 V class.

**Battery (MR-BAT6V1SET)** (Note 1)

<b>B</b>	<b>B-RJ</b>	<b>B-RJ100</b>	<b>A</b>	<b>A-RJ</b>
----------	-------------	----------------	----------	-------------

The absolute position data can be retained when the battery is mounted on the servo amplifier. When the battery life runs out, please replace the built-in MR-BAT6V1 battery. Refer to relevant Servo Amplifier Instruction Manual for installation of the battery. MR-BAT6V1SET is not required for the linear servo system or the incremental system.

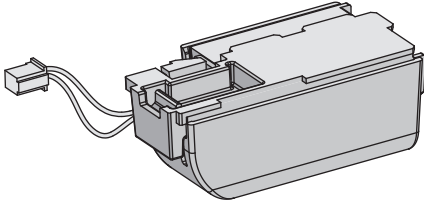
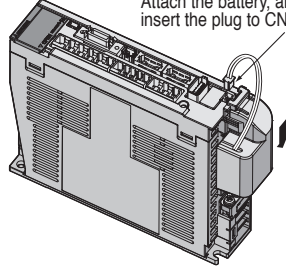
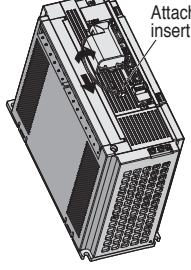
External appearance	Mounting method	
 <p>Model: MR-BAT6V1SET Nominal voltage: 6 V Nominal capacity: 1650 mAh Lithium content: 1.2 g Primary battery: 2CR17335A (CR17335A × 2 pcs. in series) Mass: 55 g (including MR-BAT6V1 battery)</p>	<p>For MR-J4-10B/A to MR-J4-350B/A, MR-J4-40B1/A1 or smaller, MR-J4-200B4/A4 or smaller</p>  <p>Attach the battery, and then insert the plug to CN4 connector.</p>	<p>For MR-J4-500B/A or larger, MR-J4-350B4/A4 or larger, MR-J4-DU900B(4) or larger, MR-J4-DU30KA(4) or larger</p>  <p>Attach the battery, and then insert the plug to CN4 connector.</p>
<p>* MR-J3BAT battery cannot be used because of the difference in voltage.</p>		

**Battery (MR-BAT6V1SET-A)** (Note 1)

<b>GF</b>	<b>GF-RJ</b>	<b>WB</b>	<b>A</b>	<b>A-RJ</b>
-----------	--------------	-----------	----------	-------------

The absolute position data can be retained when the battery is mounted on the servo amplifier. When the battery life runs out, please replace the built-in MR-BAT6V1 battery. Refer to relevant Servo Amplifier Instruction Manual for installation of the battery. MR-BAT6V1SET-A is not required for the linear servo system or the incremental system.

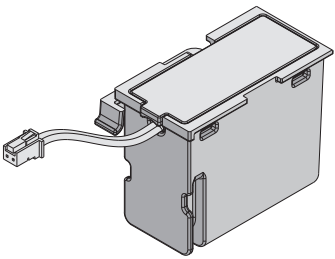
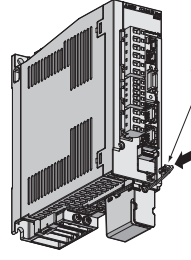
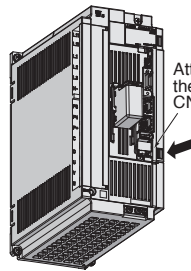
External appearance	Mounting method	
 <p>Model: MR-BAT6V1SET-A Nominal voltage: 6 V Nominal capacity: 1650 mAh Lithium content: 1.2 g Primary battery: 2CR17335A (CR17335A × 2 pcs. in series) Mass: 55 g (including MR-BAT6V1 battery)</p>	<p>MR-J4-10GF to MR-J4-350GF, MR-J4-40GF1 or smaller, MR-J4-200GF4 or smaller, MR-J4W2-0303B6, MR-J4-03A6</p>  <p>Attach the battery, and then insert the plug to CN4 connector.</p>	<p>MR-J4-500GF or larger, MR-J4-350GF4 or larger</p>  <p>Attach the battery, and then insert the plug to CN4 connector.</p>
<p>* MR-J3BAT battery cannot be used because of the difference in voltage.</p>		

Notes: 1. MR-BAT6V1SET and MR-BAT6V1SET-A is an assembled battery composed of lithium metal batteries of CR17335A. This battery is not subject to the dangerous goods (Class 9) of the UN Recommendations. To transport lithium metal batteries and lithium metal batteries contained in equipment, take actions to comply with the following regulations: the United Nations Recommendations on the Transport of Dangerous Goods, the Technical Instruction (ICAO-TI) by the International Civil Aviation Organization (ICAO), the International Air Transport Association (IATA), and the International Maritime Dangerous Goods Code (IMDG Code) by the International Maritime Organization (IMO). To transport the batteries, check the latest standards or the laws of the destination country and take actions. Contact your local sales office for more details.

Please dispose of the battery according to your local laws and regulations.

# Options/Peripheral Equipment

## Battery for Junction Battery Cable (MR-BAT6V1BJ) (Note 1, 5, 6)

GF GF-RJ B B-RJ B-RJ100 A A-RJ

## Junction Battery Cable (MR-BT6VCBL03M) (Note 5, 6)

Use these battery and junction battery cable when the absolute position data needs to be retained while the servo amplifier and the servo motor are disconnected for shipping. The servo motor does not have a super capacitor (for holding an absolute position data for a short period) in the encoder. When MR-BAT6V1BJ and MR-BT6VCBL03M are used together, the absolute position data can be held even when the servo amplifier is disconnected from the servo motor. These battery and cable are compatible with the 1-axis servo amplifier used with HG servo motor series (Note 2).

When purchasing MR-BAT6V1BJ for the first time, please purchase MR-BT6VCBL03M together. The batteries built in MR-BAT6V1BJ are not replaceable.

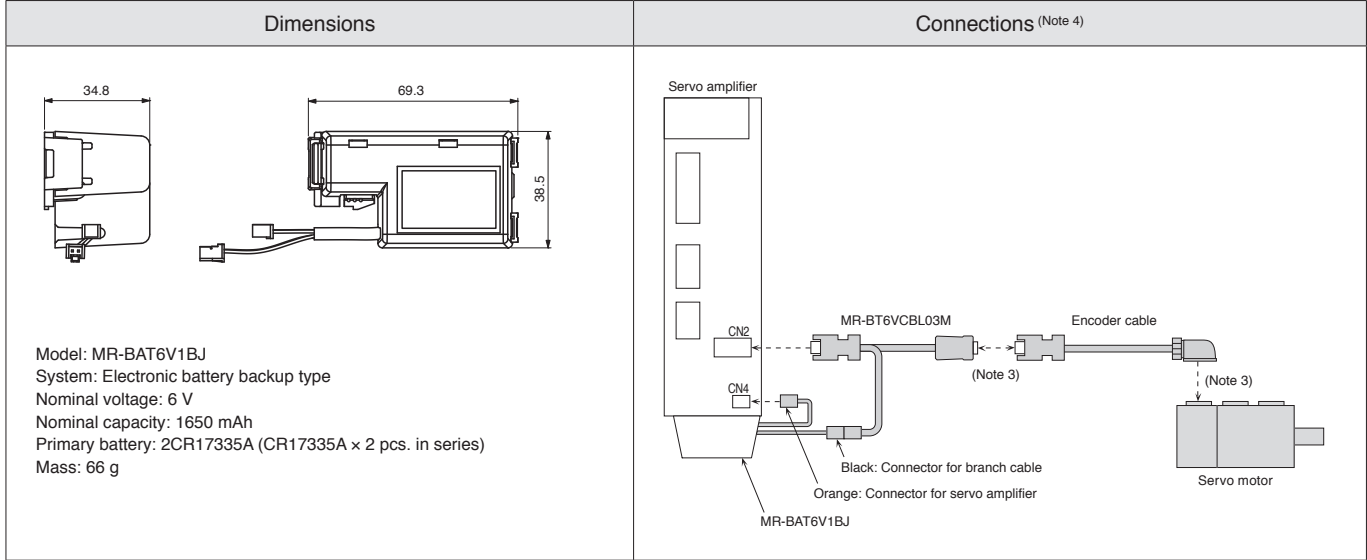

- Notes: 1. MR-BAT6V1BJ is an assembled battery composed of lithium metal batteries of CR17335A. This battery is not subject to the dangerous goods (Class 9) of the UN Recommendations. To transport lithium metal batteries and lithium metal batteries contained in equipment, take actions to comply with the following regulations: the United Nations Recommendations on the Transport of Dangerous Goods, the Technical Instruction (ICAO-TI) by the International Civil Aviation Organization (ICAO), the International Air Transport Association (IATA), and the International Maritime Dangerous Goods Code (IMDG Code) by the International Maritime Organization (IMO). To transport the batteries, check the latest standards or the laws of the destination country and take actions. Contact your local sales office for more details. Please dispose of the battery according to your local laws and regulations.
2. These battery and cable will be compatible with the direct drive motors in the future.
3. To hold the absolute position data, keep the connections from the battery to the encoder. Connections to CN2 and CN4 connectors can be disconnected.
4. Start up the absolute position detection system after MR-BAT6V1BJ and MR-BT6VCBL03M are connected.
5. This is not supported by MR-J4-03A6(-RJ).
6. When MR-BAT6V1BJ is installed to MR-J4-500GF(-RJ), the front cover does not open. Therefore, install MR-BAT6V1BJ after executing the wiring to the terminal. Contact your local sales office when using MR-BAT6V1BJ with MR-J4-350GF4(-RJ).

**Battery Case (MR-BT6VCASE)** (Note 2)

GF GF-RJ B B-RJ WB A A-RJ

**Battery (MR-BAT6V1)** (Note 1, 2)

Absolute position data of up to eight axes of the servo motors can be retained when the battery case and the batteries are used. When the direct drive motors are used, the total number of axes connected to the direct drive motors must be four or less. Refer to the following table for the connectable number of the each servo motor. The rotary servo motors and the direct drive servo motors used in incremental system, and the rotary servo motors and the synchronous encoders used for load side in the fully closed loop control system are also included in the number of the connectable axes. The linear servo motors are not included in the number of the connectable axes.

This battery case is also usable in a system having MR-J4-\_B\_(-RJ) and MR-J4W\_ \_B servo amplifiers in combination. The case stores five batteries by connecting to the connectors. The batteries are not included in the battery case. Please purchase the batteries separately.

Servo motor	Number of axes								
Rotary servo motor	0	1	2	3	4	5	6	7	8
Direct drive motor	4	4	4	4	4	3	2	1	0

Dimensions (assembled)	[Unit: mm]	MR-BAT6V1
<p>Approx. 70</p> <p>MR-BT6V1CBL_M (option)</p> <p>Mounting screw size: M4</p> <p>Mass: 0.18 kg</p>		<p>Model: MR-BAT6V1                      Nominal voltage: 6 V                      Nominal capacity: 1650 mAh                      Lithium content: 1.2 g                      Primary battery: 2CR17335A (CR17335A × 2 pcs. in series)                      Mass: 34 g</p>

Connections	
<p>For connecting to one unit of servo amplifier</p>	<p>For connecting up to eight servo amplifier axes</p>

- Notes: 1. MR-BAT6V1 is an assembled battery composed of lithium metal batteries of CR17335A. This battery is not subject to the dangerous goods (Class 9) of the UN Recommendations. To transport lithium metal batteries and lithium metal batteries contained in equipment, take actions to comply with the following regulations: the United Nations Recommendations on the Transport of Dangerous Goods, the Technical Instruction (ICAO-TI) by the International Civil Aviation Organization (ICAO), and the International Maritime Dangerous Goods Code (IMDG Code) by the International Maritime Organization (IMO). To transport the batteries, check the latest standards or the laws of the destination country and take actions. Contact your local sales office for more details.  
 Please dispose of the battery according to your local laws and regulations.  
 2. This is not supported by MR-J4W2-0303B6, MR-J4-03A6(-RJ), and servo motors with functional safety.  
 3. This is an option cable. Refer to "Cables and Connectors for Servo Amplifiers" in this catalog.

# Options/Peripheral Equipment

## Absolute Position Storage Unit (MR-BTAS01) (Note 2)

GF GF-RJ B B-RJ WB A A-RJ

This absolute position storage unit is required for configuring absolute position detection system using the direct drive motor.  
This unit is not required when the servo system is used in incremental system.

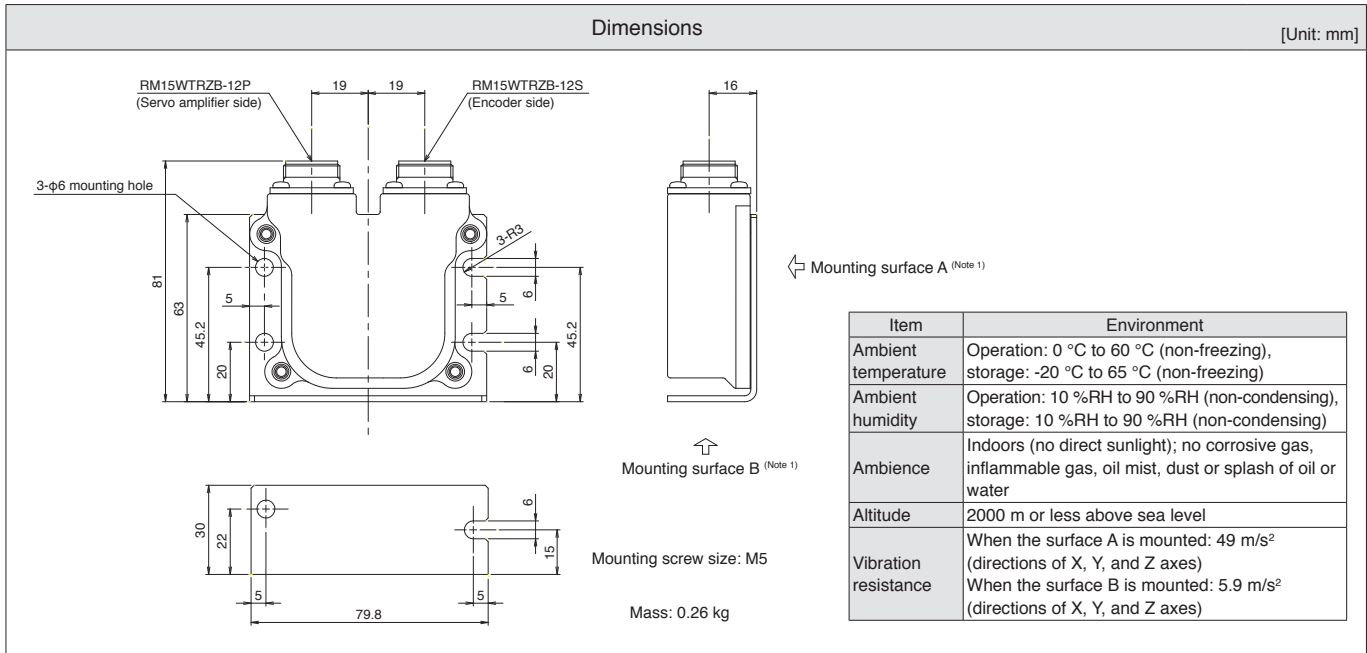

Notes: 1. When mounting the absolute position storage unit outside a cabinet, be sure to mount the surface A with 4 screws. When mounting the unit inside a cabinet, mounting the surface B with 2 screws is also possible.  
2. This is not supported by MR-J4W2-0303B6 and MR-J4-03A6(-RJ).



### Junction Terminal Block (MR-TB26A)

WB

Connect all signals via the junction terminal block.

Dimensions (Note 1)		[Unit: mm]																
	<p><b>Specifications</b></p> <table border="1" style="width: 100%; border-collapse: collapse;"> <tr> <td colspan="2">Rating</td> <td>32 V AC/DC, 0.5 A</td> </tr> <tr> <td rowspan="3">Applicable wire (terminal side)</td> <td>Stranded wire</td> <td>0.08 mm<sup>2</sup> to 1.5 mm<sup>2</sup> (AWG 28 to 14)</td> </tr> <tr> <td>Solid wire</td> <td>ø0.32 mm to 1.2 mm</td> </tr> <tr> <td>Insulator OD</td> <td>3.4 mm or shorter</td> </tr> <tr> <td colspan="2">Operating tool</td> <td>210-619 (WAGO) or an equivalent</td> </tr> <tr> <td colspan="2">Strip length</td> <td>5 mm to 6 mm</td> </tr> </table>	Rating		32 V AC/DC, 0.5 A	Applicable wire (terminal side)	Stranded wire	0.08 mm <sup>2</sup> to 1.5 mm <sup>2</sup> (AWG 28 to 14)	Solid wire	ø0.32 mm to 1.2 mm	Insulator OD	3.4 mm or shorter	Operating tool		210-619 (WAGO) or an equivalent	Strip length		5 mm to 6 mm	
Rating		32 V AC/DC, 0.5 A																
Applicable wire (terminal side)	Stranded wire	0.08 mm <sup>2</sup> to 1.5 mm <sup>2</sup> (AWG 28 to 14)																
	Solid wire	ø0.32 mm to 1.2 mm																
	Insulator OD	3.4 mm or shorter																
Operating tool		210-619 (WAGO) or an equivalent																
Strip length		5 mm to 6 mm																

Notes: 1. The lengths in brackets are applicable when the junction terminal block is mounted on a 35 mm wide DIN rail.

### Junction Terminal Block (MR-TB50)

A A-RJ

Connect all signals via the junction terminal block.

Dimensions		[Unit: mm]
	<p>Terminal screw size: M3.5                  Applicable wire: 2 mm<sup>2</sup> maximum                  Crimp terminal width: 7.2 mm or shorter                  Mounting screw size: M4</p>	

Servo Amplifiers

Rotary Servo Motors

Linear Servo Motors

Direct Drive Motors

Options/Peripheral Equipment

LVS/Wires

Product List

Precautions

# Options/Peripheral Equipment

[Products on the Market]

## Junction Terminal Block (DG2SV3TB), Servo Amplifier Connection Cable (DG4SV2CB\_)

GF GF-RJ B B-RJ B-RJ100

This terminal block is used for wiring signals.

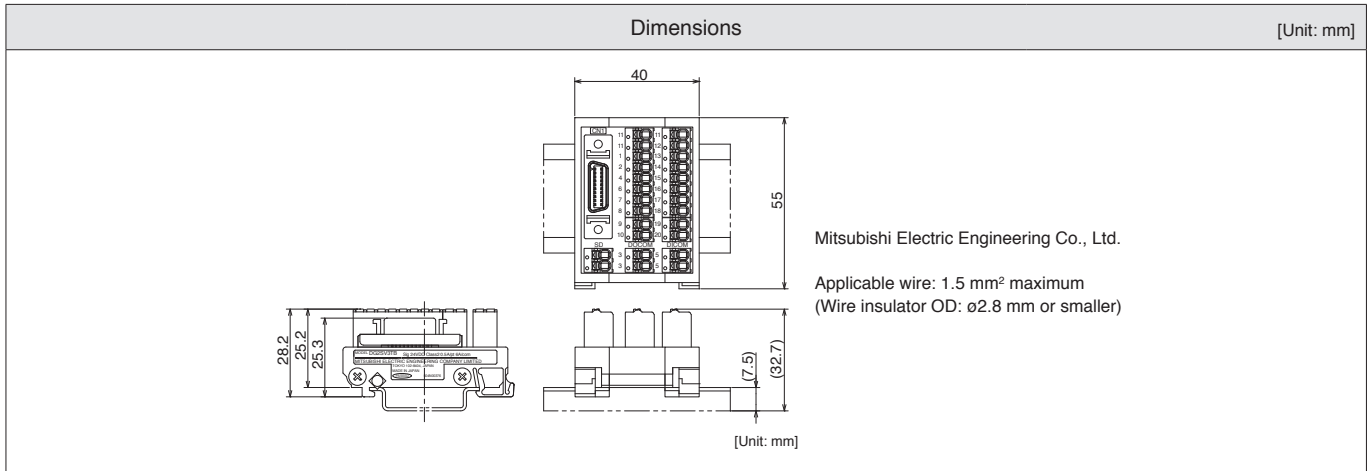

[Products on the Market]

## Junction Terminal Block (PS7DW-20V14B-F)

GF GF-RJ B B-RJ B-RJ100

This terminal block is used for wiring signals.

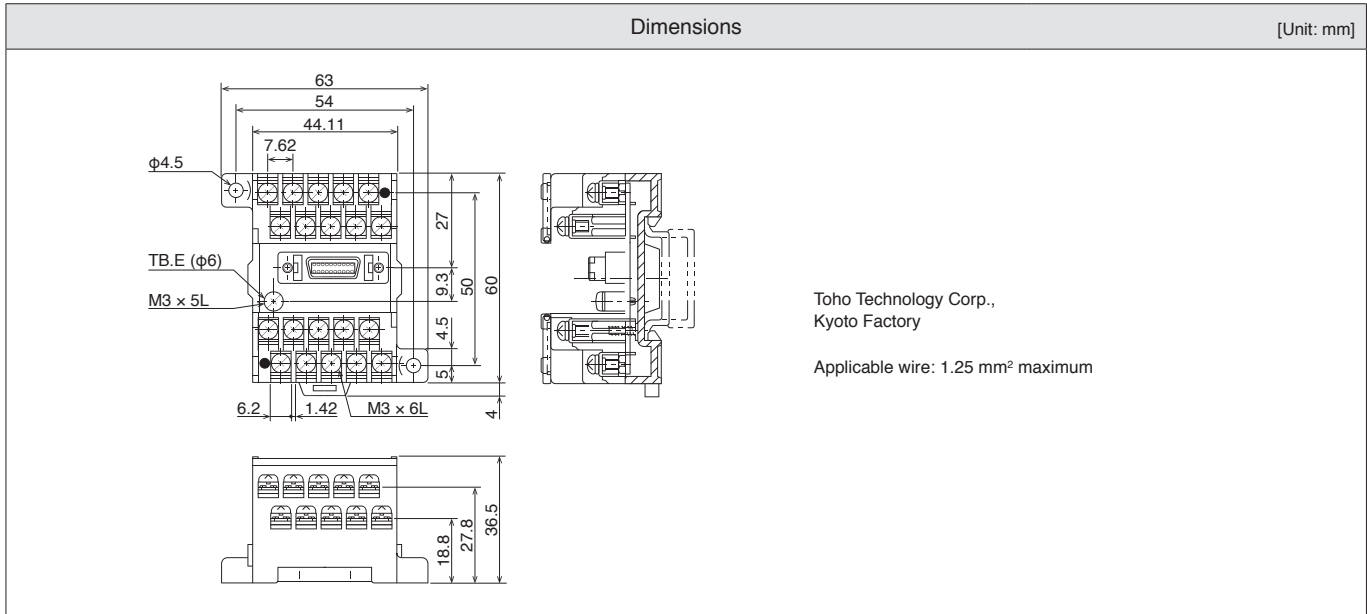

[Products on the Market]

## Junction Terminal Block (DG2SV1TB), Servo Amplifier Connection Cable (DG4SV1CB\_)

A A-RJ

This terminal block is used for wiring signals.

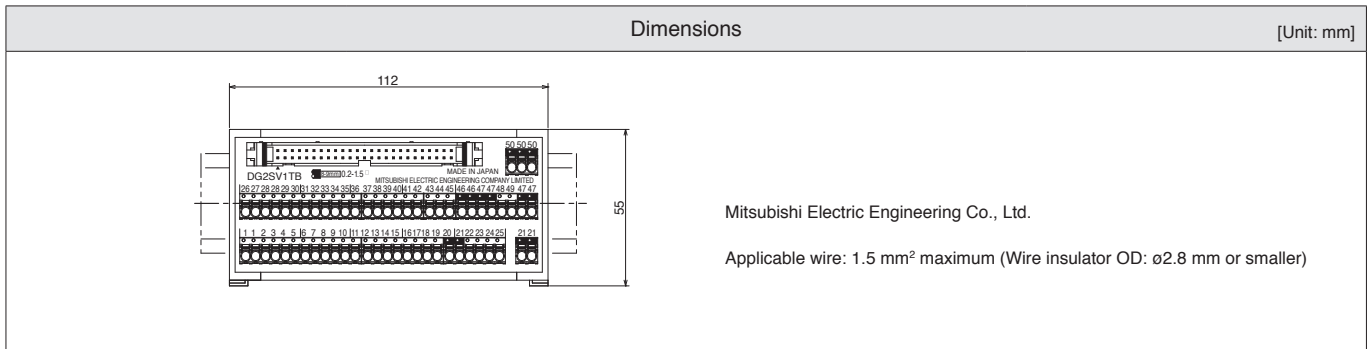

**Panel Through Attachment (MR-J4ACN15K, MR-J3ACN)**

**GF GF-RJ B B-RJ A A-RJ**

By using the panel through attachment on the servo amplifiers of 11 kW to 22 kW, the heat generating section can be mounted outside a cabinet, enabling to dissipate about 50% of the heat from the unit to outside the cabinet. This allows smaller cabinet size.

Servo amplifier model	Panel through attachment model	Fig.
MR-J4-11KGF/B/A, MR-J4-11KGF4/B4/A4 MR-J4-15KGF/B/A, MR-J4-15KGF4/B4/A4	MR-J4ACN15K	A
MR-J4-22KGF/B/A, MR-J4-22KGF4/B4/A4	MR-J3ACN	B

	Mounting [Unit: mm]	Panel cut dimensions [Unit: mm]
A		
B		

**Manual Pulse Generator (MR-HDP01)**

**A-RJ**

Dimensions [Unit: mm]	Mounting [Unit: mm]

# Options/Peripheral Equipment

## Parameter Unit (MR-PRU03) (Note 3)

A A-RJ

Parameter unit with a 16 characters × 4 lines display, is available as an option.

The parameter unit (Note 1) connected with servo amplifiers enables setting of point table data (Note 2) and parameters, and test operation without MR Configurator2.

### Wiring and communication method

- RS-422 communication method
- Connectable with one unit of the servo amplifier with the commercial LAN cable
- Connectable up to 32 axes with multi-drop system

### Dimensions

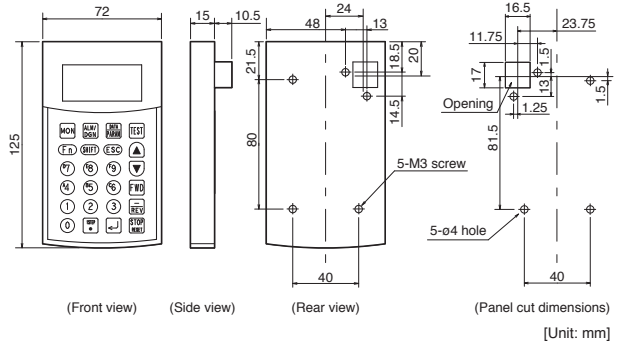
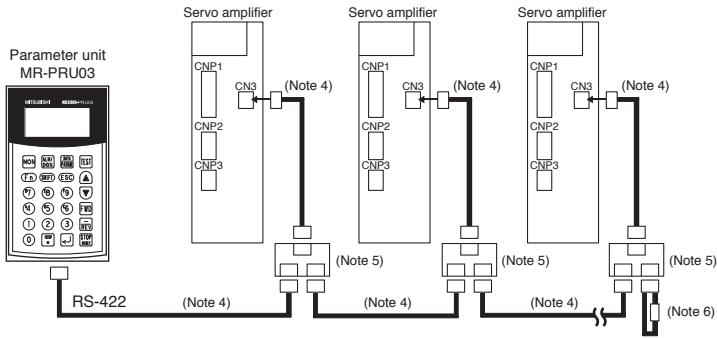

### Specifications

Parameter unit model		MR-PRU03
Power supply		Receives power from the servo amplifier (drive unit)
Functions	Parameter mode	Basic setting parameters, gain/filter parameters, extension setting parameters, I/O setting parameters, extension setting 2 parameters, extension setting 3 parameters, option setting parameters, special setting parameters, linear/DD motor setting parameters, positioning control parameters
	Monitor mode	Cumulative feedback pulses, servo motor speed, position deviation, cumulative command pulses, command pulse frequency, regenerative load ratio, effective load ratio, peak load ratio, load to motor inertia ratio, bus voltage, point table No./program No./station position No., step No., override voltage, cam axis current value per cycle, cam reference position, cam axis current feed value, execute cam No., execute cam stroke amount, main shaft current value, main shaft current value per cycle, etc.
	Diagnosis mode	External I/O (DIDO) display, software version, automatic VC offset, servo motor information, cumulative power-on
	Alarm mode	Current alarm, alarm history
	Test operation mode	JOG operation, positioning operation, forced digital output (DO), single-step feed
	Point table mode	Position data, servo motor speed, acceleration/deceleration time constants, dwell, auxiliary function, M code
Display		LCD (16 characters × 4 lines)
Environment	Ambient temperature	Operation: -10 °C to 55 °C (non-freezing), storage: -20 °C to 65 °C (non-freezing)
	Ambient humidity	Operation/storage: 5 %RH to 90 %RH (non-condensing)
	Ambience	Indoors (no direct sunlight); no corrosive gas, inflammable gas, oil mist or dust
Mass [g]		130

Notes: 1. Use MR-PRU03 with software version B0 or later. Parameter unit can be used by setting [Pr. PF34] to "1 \_\_\_".

2. Programs cannot be edited with the parameter unit.

3. This is not supported by MR-J4-03A6(-RJ).

4. Use 10BASE-T cable (EIA568 compliant), etc.

Keep the distance between the branch connector and servo amplifier as short as possible.

5. Branch connector, BMJ-8 (HACHIKO ELECTRIC CO., LTD) is recommended. Refer to "Products on the Market for Servo Amplifiers" in this catalog.

6. For the final axis, terminate RDP (3-pin) and RDN (6-pin) of the receiving side (servo amplifier) with 150 Ω resistor.

**Radio Noise Filter (FR-BIF, FR-BIF-H)**

GF GF-RJ B B-RJ B-RJ100 WB A A-RJ

This filter suppresses noise from the power supply side of the servo amplifier, especially effective for the radio frequency bands of 10 MHz or lower. The FR-BIF(-H) is designed to be installed on the input side.

Dimensions [Unit: mm]	Connections
	<p>Do not use the FR-BIF(-H) on the output side of the servo amplifier. Wiring should be as short as possible, and grounding is required. Be sure to insulate the unused wire when using the FR-BIF with a 1-phase power supply.</p> <p>For 3.5 kW or smaller 1-axis servo amplifiers, and multi-axis servo amplifiers</p> <p>For 5 kW or larger 1-axis servo amplifiers</p> <p>200 V /100 V class: FR-BIF 400 V class: FR-BIF-H</p>

**Line Noise Filter (FR-BSF01, FR-BLF)**

GF GF-RJ B B-RJ B-RJ100 WB A A-RJ

This filter suppresses noise from the power supply side and the output side of the servo amplifier. The FR-BSF01 and FR-BLF are also effective in suppressing high-frequency leakage current (zero-phase current), especially the range of 0.5 MHz to 5 MHz.

Dimensions [Unit: mm]	Connections
<p><b>FR-BSF01</b> For wire size of 3.5 mm<sup>2</sup> (AWG 12) or smaller</p> <p><b>FR-BLF</b> For wire size of 5.5 mm<sup>2</sup> (AWG 10) or larger</p>	<p>The line noise filters can be mounted on lines of the main circuit power supply (L1, L2, and L3) and of the servo motor power (U, V, and W). Pass each of the wires through the line noise filter an equal number of times in the same direction. For wires of the main circuit power supply, the effect of the filter rises as the number of passes increases, but generally four passes would be appropriate. For the servo motor power lines, passes must be four times or less. Do not pass the grounding wire through the filter. Otherwise, the effect of the filter will drop.</p> <p>Wind the wires by passing through the filter to satisfy the required number of passes as shown in Example 1. If the wires are too thick to wind, use two or more filters to have the required number of passes as shown in Example 2.</p> <p>Place the line noise filters as close to the servo amplifier as possible for their best performance.</p> <p><b>Example 1</b></p> <p><b>Example 2</b></p>

**Data Line Filter**

GF GF-RJ B B-RJ B-RJ100 WB A A-RJ

This filter is effective in preventing noise when attached to the pulse output cable of the pulse train output controller or the motor encoder cable.

- Example) ESD-SR-250 (manufactured by TOKIN Corporation)  
ZCAT3035-1330 (manufactured by TDK)  
GRFC-13 (manufactured by Kitagawa Industries Co., Ltd.)  
E04SRM563218 (manufactured by Seiwa Electric Mfg. Co., Ltd.)

**Surge Killer**

GF GF-RJ B B-RJ B-RJ100 WB A A-RJ

Attach surge killers to AC relays and AC valves around the servo amplifier. Attach diodes to DC relays and DC valves.

- Example) Surge killer: CR-50500 (manufactured by Okaya Electric Industries Co., Ltd.)  
Diode: A diode with breakdown voltage four or more times greater than the relay drive voltage, and with current capacity two or more times greater than the relay drive current.

# Options/Peripheral Equipment

## EMC Filter

**GF GF-RJ B B-RJ B-RJ100 WB A A-RJ**

The following filters are recommended as a filter compliant with the EMC directive for the power supply of the servo amplifier.

Servo amplifier	EMC filter model (Note 3)	Rated current [A]	Rated voltage [V AC]	Leakage current [mA]	Mass [kg]	Fig.
MR-J4-10GF/B/A to MR-J4-100GF/B/A MR-J4-10GF1/B1/A1 to MR-J4-40GF1/ B1/A1 MR-J4W2-22B MR-J4W2-44B MR-J4W3-222B	HF3010A-UN (Note 1, 2)	10	250	5	3.5	A
MR-J4-200GF/B/A, MR-J4-350GF/B/A MR-J4W2-77B, MR-J4W2-1010B MR-J4W3-444B	HF3030A-UN (Note 1, 2)	30	250	5	5.5	B
MR-J4-500GF/B/A, MR-J4-700GF/B/A	HF3040A-UN (Note 1, 2)	40	250	6.5	6.0	C
MR-J4-11KGF/B/A to MR-J4-22KGF/B/A	HF3100A-UN (Note 1, 2)	100	250	6.5	12	
	FTB-100-355-L (Note 2, 4)	100	500	40	5.3	I
MR-J4-60GF4/B4/A4, MR-J4-100GF4/B4/A4	TF3005C-TX (Note 1)	5	500	5.5	6.0	D
MR-J4-200GF4/B4/A4 to MR-J4-700GF4/B4/A4	TF3020C-TX (Note 1)	20	500	5.5	6.0	
MR-J4-11KGF4/B4/A4	TF3030C-TX (Note 1)	30	500	5.5	7.5	
MR-J4-15KGF4/B4/A4	TF3040C-TX (Note 1)	40	500	5.5	12.5	E
MR-J4-22KGF4/B4/A4	TF3060C-TX (Note 1)	60	500	5.5	12.5	
	FTB-80-355-L (Note 2, 4)	80	500	80	5.3	I

Power regeneration converter unit/ resistance regeneration converter unit	EMC filter model (Note 3)	Rated current [A]	Rated voltage [V AC]	Leakage current [mA]	Mass [kg]	Fig.
MR-CV11K MR-CV18K	HF3100A-UN (Note 1, 2)	100	250	6.5	12	C
MR-CV30K MR-CV37K MR-CV45K MR-CV55K MR-CR55K	FTB-100-355-L (Note 2, 4)	100	500	40	5.3	I
	HF3200A-UN (Note 1, 2)	200	250	9	18	F
MR-CV11K4	TF3030C-TX (Note 1)	30	500	5.5	7.5	D
	FTB-80-355-L (Note 2, 4)	80	500	80	5.3	I
MR-CV18K4	TF3060C-TX (Note 1)	60	500	5.5	12.5	E
	FTB-80-355-L (Note 2, 4)	80	500	80	5.3	I
MR-CV30K4 MR-CV37K4 MR-CV45K4 MR-CV55K4 MR-CV75K4 MR-CR55K4	TF3150C-TX (Note 1)	150	500	5.5	31	G
	FTB-150-355-L (Note 2, 4)	150	500	80	7.8	H

Notes: 1. Manufactured by Soshin Electric Co., Ltd.

2. When using these EM filters, use a surge protector of RSPD series (manufactured by Okaya Electric Industries Co., Ltd.) or LT-CS-WS series (manufactured by Soshin Electric Co., Ltd.). Refer to "EMC Installation Guidelines" for details."

3. When using the EMC filter, install one EMC filter for each servo amplifier, power regeneration converter unit, or resistance regeneration converter unit.

4. Manufactured by COSEL Co., Ltd.

### Dimensions

[Unit: mm]

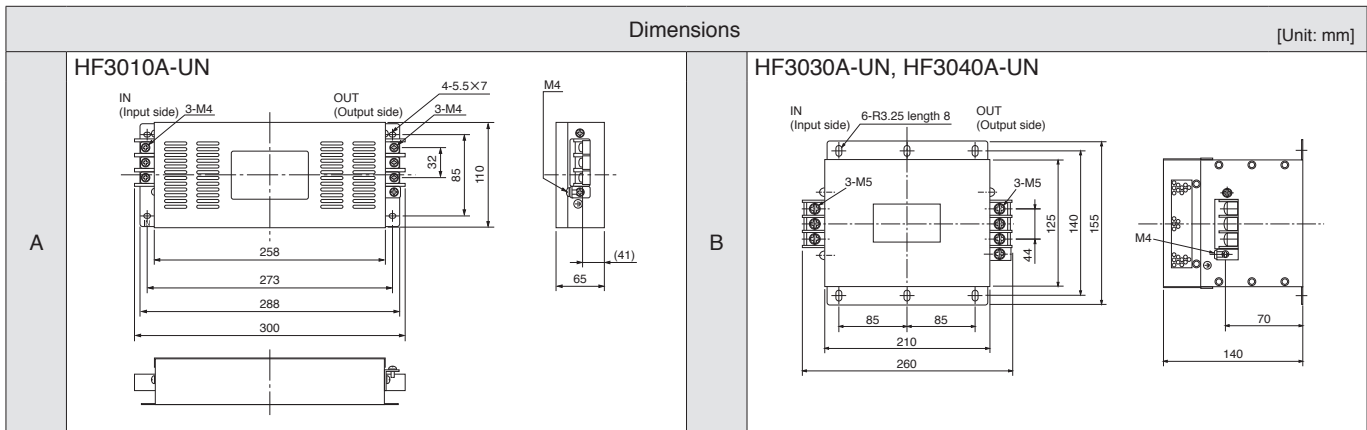

EMC Filter

GF GF-RJ B B-RJ B-RJ100 WB A A-RJ

Dimensions		[Unit: mm]
C	<p><b>HF-3100A-UN</b></p> <p>IN (Input side) 2-ø6.5 × 8 3-M8 2-ø6.5 OUT (Output side) 3-M8</p> <p>145 165 380 400 M6 160</p>	<p><b>HF3005C-TX, HF-3020C-TX, HF3030C-TX</b></p> <p>IN (Input side) 6-R3.25 length 8 (For M6) OUT (Output side) 3-M4 M4</p> <p>16 16 (12.2) 125 140 155 100 100 290 308 332 150 (67.5) 170</p>
	<p><b>HF-3040C-TX, TF3060C-TX</b></p> <p>3-M6 IN (Input side) 8-R3.25 length 8 M4 OUT (Output side) 3-M6</p> <p>22 22 (17) 100 100 100 390 412 438 145 160 175 M6 (91.5) 180 (190) 200</p>	
E	<p><b>TF3150C-TX</b></p> <p>IN (Input side) 8-R 4.25 length 12 (For M6) OUT (Output side) M8</p> <p>27 27 3-M8 3-M8 23 200 225 258 M4 M4 110 150 150 150 452 500 210 260</p>	<p><b>FTB-150-355-L</b></p> <p>3-M8 (Option-S: Hexagon socket head cap screws) Input terminal 400 359 3-M8 (Option-S: Hexagon socket head cap screws) Output terminal</p> <p>100 26 28 M6 (Option-S: Hexagon socket head cap screw) Terminal cover Terminal cover M6 (Option-S: Hexagon socket head cap screw) Protection earth (PE) 183 210 183 20</p>
G	<p><b>FTB-150-355-L</b></p> <p>3-M8 (Option-S: Hexagon socket head cap screws) Input terminal 400 359 3-M8 (Option-S: Hexagon socket head cap screws) Output terminal</p> <p>100 26 28 M6 (Option-S: Hexagon socket head cap screw) Terminal cover Terminal cover M6 (Option-S: Hexagon socket head cap screw) Protection earth (PE) 183 210 183 20</p>	<p><b>FTB-80-355-L, FTB-100-355-L</b></p> <p>3-M8 (Option-S: Hexagon socket head cap screws) Input 350 309 3-M8 (Option-S: Hexagon socket head cap screws) Output</p> <p>100 26 28 M6 (Option-S: Hexagon socket head cap screw) Terminal cover Terminal cover M6 (Option-S: Hexagon socket head cap screw) Protection earth (PE) 143 170 143 20</p>
F	<p><b>FTB-150-355-L</b></p> <p>3-M8 (Option-S: Hexagon socket head cap screws) Input terminal 400 359 3-M8 (Option-S: Hexagon socket head cap screws) Output terminal</p> <p>100 26 28 M6 (Option-S: Hexagon socket head cap screw) Terminal cover Terminal cover M6 (Option-S: Hexagon socket head cap screw) Protection earth (PE) 183 210 183 20</p>	<p><b>FTB-80-355-L, FTB-100-355-L</b></p> <p>3-M8 (Option-S: Hexagon socket head cap screws) Input 350 309 3-M8 (Option-S: Hexagon socket head cap screws) Output</p> <p>100 26 28 M6 (Option-S: Hexagon socket head cap screw) Terminal cover Terminal cover M6 (Option-S: Hexagon socket head cap screw) Protection earth (PE) 143 170 143 20</p>
H	<p><b>FTB-150-355-L</b></p> <p>3-M8 (Option-S: Hexagon socket head cap screws) Input terminal 400 359 3-M8 (Option-S: Hexagon socket head cap screws) Output terminal</p> <p>100 26 28 M6 (Option-S: Hexagon socket head cap screw) Terminal cover Terminal cover M6 (Option-S: Hexagon socket head cap screw) Protection earth (PE) 183 210 183 20</p>	<p><b>FTB-80-355-L, FTB-100-355-L</b></p> <p>3-M8 (Option-S: Hexagon socket head cap screws) Input 350 309 3-M8 (Option-S: Hexagon socket head cap screws) Output</p> <p>100 26 28 M6 (Option-S: Hexagon socket head cap screw) Terminal cover Terminal cover M6 (Option-S: Hexagon socket head cap screw) Protection earth (PE) 143 170 143 20</p>
I	<p><b>FTB-150-355-L</b></p> <p>3-M8 (Option-S: Hexagon socket head cap screws) Input terminal 400 359 3-M8 (Option-S: Hexagon socket head cap screws) Output terminal</p> <p>100 26 28 M6 (Option-S: Hexagon socket head cap screw) Terminal cover Terminal cover M6 (Option-S: Hexagon socket head cap screw) Protection earth (PE) 183 210 183 20</p>	<p><b>FTB-80-355-L, FTB-100-355-L</b></p> <p>3-M8 (Option-S: Hexagon socket head cap screws) Input 350 309 3-M8 (Option-S: Hexagon socket head cap screws) Output</p> <p>100 26 28 M6 (Option-S: Hexagon socket head cap screw) Terminal cover Terminal cover M6 (Option-S: Hexagon socket head cap screw) Protection earth (PE) 143 170 143 20</p>

Servo Amplifiers

Rotary Servo Motors

Linear Servo Motors

Direct Drive Motors

Options/Peripheral Equipment

LVS/Wires

Product List

Precautions

## EMC Filter

GF GF-RJ B B-RJ B-RJ100 WB A A-RJ

### Connections

For MR-J4-GF/B/A, MR-J4W\_-\_B  
3-phase 200 V AC/400 V AC

1-phase 200 V AC

1-phase 100 V AC

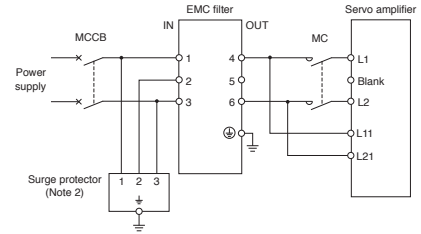
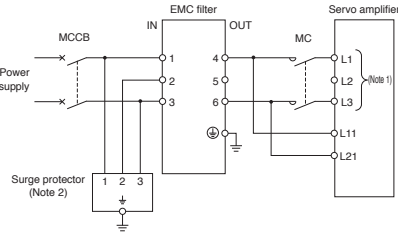
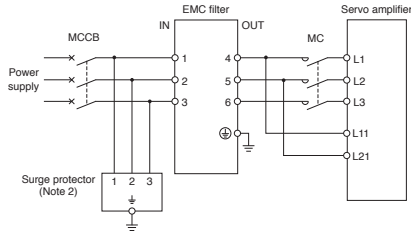

For MR-CV and MR-J4-DU\_B

For MR-CR and MR-J4-DU\_B/A

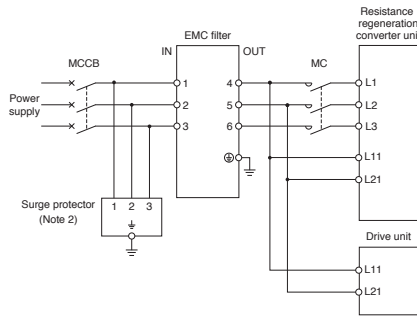
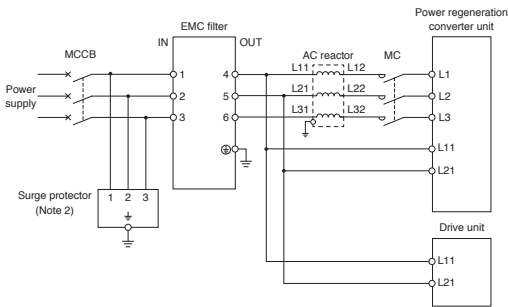

Notes: 1. Connect the power supply to L1 and L3 terminals. Do not connect anything to L2. The connections are different from MR-J3 series servo amplifiers. Be careful not to make a connection error when replacing MR-J3 with MR-J4.  
2. This is for when a surge protector is connected.

## Surge Protector

GF GF-RJ B B-RJ B-RJ100 WB A A-RJ

Attach surge protectors of RSPD series (manufactured by Okaya Electric Industries Co., Ltd.) or LT-CS-WS series (manufactured by Soshin Electric Co., Ltd.) to the servo amplifiers.



**Power Factor Improving DC Reactor (FR-HEL, FR-HEL-H, MR-DCL)** **GF** **GF-RJ** **B** **B-RJ** **A** **A-RJ**

This boosts the power factor of servo amplifier and reduces the power supply capacity. Use either the DC reactor or the AC reactor. As compared to the AC reactor (FR-HAL or FR-HAL-H), the DC reactor (FR-HEL or FR-HEL-H) is more recommended since the DC reactor is more effective in power factor improvement, smaller and lighter, and its wiring is easier. (The DC reactor uses two wires, while the AC reactor uses six wires.)

Servo amplifier model	Power factor improving DC reactor model	Fig.
MR-J4-10GF/B/A	FR-HEL-0.4K	A
MR-J4-20GF/B/A		
MR-J4-40GF/B/A	FR-HEL-0.75K	
MR-J4-60GF/B/A	FR-HEL-1.5K	
MR-J4-70GF/B/A		
MR-J4-100GF/B/A	FR-HEL-2.2K	
MR-J4-200GF/B/A	FR-HEL-3.7K	C
MR-J4-350GF/B/A	FR-HEL-7.5K	D
MR-J4-500GF/B/A	FR-HEL-11K	
MR-J4-700GF/B/A	FR-HEL-15K	
MR-J4-11KGF/B/A	FR-HEL-22K	E
MR-J4-15KGF/B/A		
MR-J4-22KGF/B/A	FR-HEL-30K	F
MR-J4-60GF4/B4/A4	FR-HEL-H1.5K	
MR-J4-100GF4/B4/A4	FR-HEL-H2.2K	

Servo amplifier model	Power factor improving DC reactor model	Fig.
MR-J4-200GF4/B4/A4	FR-HEL-H3.7K	G
MR-J4-350GF4/B4/A4	FR-HEL-H7.5K	
MR-J4-500GF4/B4/A4	FR-HEL-H11K	H
MR-J4-700GF4/B4/A4	FR-HEL-H15K	
MR-J4-11KGF4/B4/A4	FR-HEL-H22K	I
MR-J4-15KGF4/B4/A4		
MR-J4-22KGF4/B4/A4	FR-HEL-H30K	

Resistance regeneration converter unit model	Drive unit model	Power factor improving DC reactor model	Fig.
MR-CR55K	MR-J4-DU30KB/A	MR-DCL30K	J
	MR-J4-DU37KB/A	MR-DCL37K	
MR-CR55K4	MR-J4-DU30KB4/A4	MR-DCL30K-4	
	MR-J4-DU37KB4/A4	MR-DCL37K-4	
	MR-J4-DU45KB4/A4	MR-DCL45K-4	
	MR-J4-DU55KB4/A4	MR-DCL55K-4	

**Connections**

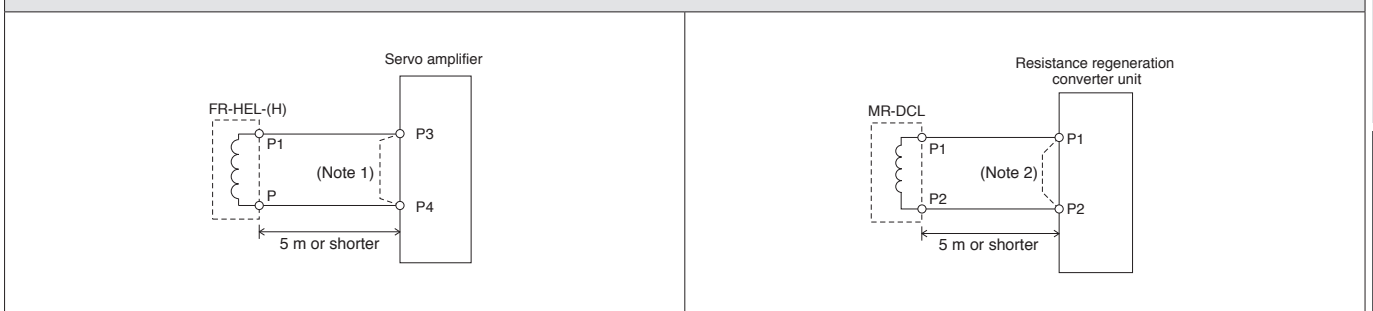

Notes: 1. Disconnect a short-circuit bar between P3 and P4 when using the power factor improving DC reactor.  
 2. Disconnect a short-circuit bar between P1 and P2 when using the power factor improving DC reactor.

**Dimensions**

**A**

Model	Variable dimensions [mm]							Mass [kg]	Wire size (Note 2) [mm <sup>2</sup> ]
	D (Note 1)	D1	W	W1	H	H1	H2		
FR-HEL-0.4K	61	28	70	60	71	61	48	0.4	2 (AWG 14)
FR-HEL-0.75K	61	28	85	74	81	71	59	0.5	
FR-HEL-1.5K	70	33	85	74	81	71	59	0.8	
FR-HEL-2.2K	70	33	85	74	81	71	59	0.9	

Notes: 1. This indicates the maximum dimension. The dimension varies depending on the bending degree of the input/output lines.  
 2. The wire size is applicable when 600 V grade heat-resistant polyvinyl chloride insulated wire (HIV wires) is used.

Power Factor Improving DC Reactor (FR-HEL)

GF GF-RJ B B-RJ A A-RJ

Dimensions

B

Model	Variable dimensions [mm]				Mass [kg]	Wire size (Note 2) [mm <sup>2</sup> ]
	D (Note 1)	D1	D2	D3		
FR-HEL-3.7K	82	39	66	56	1.4	2 (AWG 14)

---

C

Model	Mass [kg]	Wire size (Note 2) [mm <sup>2</sup> ]
FR-HEL-7.5K	2.5	3.5 (AWG 12)

Notes: 1. This indicates the maximum dimension. The dimension varies depending on the bending degree of the input/output lines.  
 2. The wire size is applicable when 600 V grade heat-resistant polyvinyl chloride insulated wire (HIV wires) is used.

Power Factor Improving DC Reactor (FR-HEL)

GF GF-RJ B B-RJ A A-RJ

Dimensions

**D**

Terminal screw M6

Grounding terminal M6 x 12

Mounting screw M6

Model	Variable dimensions [mm]						Mass [kg]	Wire size [mm <sup>2</sup> ] (Note 2)
	D (Note 1)	D1	D2	D3	H	H1		
FR-HEL-11K	112	47	92	78	138	118	3.1	5.5 (AWG 10)
FR-HEL-15K	115	49	97	83	142	120	3.8	8 (AWG 8) 14 (AWG 6) (Note 3)

**E**

Grounding terminal M6x12

Crimp terminal

Mounting screw M6

Model	Variable dimensions [mm]							Mass [kg]	Wire size [mm <sup>2</sup> ] (Note 2)
	D (Note 1)	D1	D2	D3	W	W1	H		
FR-HEL-22K	175	115	117	103	105	64	93	4.8	22 (AWG 4)
FR-HEL-30K	200	135	125	100	114	72	100	6.7	38 (AWG 2)

- Notes: 1. This indicates the maximum dimension. The dimension varies depending on the bending degree of the input/output lines.  
 2. The wire size is applicable when 600 V grade heat-resistant polyvinyl chloride insulated wire (HIV wires) is used.  
 3. When using FR-HEL-15K, select a wire of 8 mm<sup>2</sup> (AWG 8) for MR-J4-700GF/B/A, and 14 mm<sup>2</sup> (AWG 6) for MR-J4-11KGF/B/A.

Servo Amplifiers  
 Rotary Servo Motors  
 Linear Servo Motors  
 Direct Drive Motors  
 Options/Peripheral Equipment  
 LV5/Wires  
 Product List  
 Precautions

Power Factor Improving DC Reactor (FR-HEL, FR-HEL-H)

GF GF-RJ B B-RJ A A-RJ

Dimensions

**F**

Model	Variable dimensions [mm]								Mass [kg]	Wire size [mm <sup>2</sup> ] (Note 2)
	D (Note 1)	D1	D2	D3	W	H	H1	H2		
FR-HEL-H1.5K	80	36	74	54	66	100	87	75	1.0	2 (AWG 14)
FR-HEL-H2.2K	80	38	74	54	76	110	97	85	1.3	

**G**

Model	Variable dimensions [mm]									Mounting screw	Grounding terminal	Mass [kg]	Wire size [mm <sup>2</sup> ] (Note 2)
	D (Note 1)	D1	D2	D3	W	W1	H	H1	H2				
FR-HEL-H3.7K	95	39	89	69	86	55	128	114	94	M4	M4 x 8	2.3	2 (AWG 14)
FR-HEL-H7.5K	105	47	100	80	96	60	136	122	102	M5	M5 x 10	3.5	

Notes: 1. This indicates the maximum dimension. The dimension varies depending on the bending degree of the input/output lines.  
 2. The wire size is applicable when 600 V grade heat-resistant polyvinyl chloride insulated wire (HIV wires) is used.

**Power Factor Improving DC Reactor  
(FR-HEL, FR-HEL-H, MR-DCL)**

GF GF-RJ B B-RJ A A-RJ

Dimensions																																																															
H		<table border="1" style="width: 100%; border-collapse: collapse;"> <thead> <tr> <th>Model</th> <th>Mass [kg]</th> <th>Wire size [mm<sup>2</sup>] (Note 2)</th> </tr> </thead> <tbody> <tr> <td>FR-HEL-H11K</td> <td>4.5</td> <td>3.5 (AWG 12)</td> </tr> </tbody> </table>	Model	Mass [kg]	Wire size [mm <sup>2</sup> ] (Note 2)	FR-HEL-H11K	4.5	3.5 (AWG 12)																																																							
Model	Mass [kg]	Wire size [mm <sup>2</sup> ] (Note 2)																																																													
FR-HEL-H11K	4.5	3.5 (AWG 12)																																																													
I		<table border="1" style="width: 100%; border-collapse: collapse;"> <thead> <tr> <th rowspan="2">Model</th> <th colspan="9">Variable dimensions [mm]</th> <th rowspan="2">Mass [kg]</th> <th rowspan="2">Wire size [mm<sup>2</sup>] (Note 2)</th> </tr> <tr> <th>D (Note 1)</th> <th>D1</th> <th>D2</th> <th>D3</th> <th>W</th> <th>W1</th> <th>H</th> <th>H1</th> <th>H2</th> </tr> </thead> <tbody> <tr> <td>FR-HEL-H15K</td> <td>125</td> <td>57</td> <td>115</td> <td>95</td> <td>105</td> <td>75</td> <td>152</td> <td>130</td> <td>111</td> <td>5.0</td> <td>5.5 (AWG 10) 8 (AWG 8) (Note 3)</td> </tr> <tr> <td>FR-HEL-H22K</td> <td>120</td> <td>55</td> <td>95</td> <td>75</td> <td>133</td> <td>90</td> <td>180</td> <td>157</td> <td>137</td> <td>6.0</td> <td>8 (AWG 8)</td> </tr> <tr> <td>FR-HEL-H30K</td> <td>120</td> <td>58</td> <td>100</td> <td>80</td> <td>133</td> <td>90</td> <td>180</td> <td>157</td> <td>137</td> <td>6.5</td> <td>14 (AWG 6)</td> </tr> </tbody> </table>	Model	Variable dimensions [mm]									Mass [kg]	Wire size [mm <sup>2</sup> ] (Note 2)	D (Note 1)	D1	D2	D3	W	W1	H	H1	H2	FR-HEL-H15K	125	57	115	95	105	75	152	130	111	5.0	5.5 (AWG 10) 8 (AWG 8) (Note 3)	FR-HEL-H22K	120	55	95	75	133	90	180	157	137	6.0	8 (AWG 8)	FR-HEL-H30K	120	58	100	80	133	90	180	157	137	6.5	14 (AWG 6)				
Model	Variable dimensions [mm]									Mass [kg]	Wire size [mm <sup>2</sup> ] (Note 2)																																																				
	D (Note 1)	D1	D2	D3	W	W1	H	H1	H2																																																						
FR-HEL-H15K	125	57	115	95	105	75	152	130	111	5.0	5.5 (AWG 10) 8 (AWG 8) (Note 3)																																																				
FR-HEL-H22K	120	55	95	75	133	90	180	157	137	6.0	8 (AWG 8)																																																				
FR-HEL-H30K	120	58	100	80	133	90	180	157	137	6.5	14 (AWG 6)																																																				
J		<table border="1" style="width: 100%; border-collapse: collapse;"> <thead> <tr> <th rowspan="2">Model</th> <th colspan="5">Variable dimensions [mm]</th> <th rowspan="2">Mass [kg]</th> <th rowspan="2">Terminal screw size</th> <th rowspan="2">Wire size [mm<sup>2</sup>] (Note 2)</th> </tr> <tr> <th>W</th> <th>D</th> <th>H</th> <th>W1</th> <th>X</th> </tr> </thead> <tbody> <tr> <td>MR-DCL30K</td> <td rowspan="2">135</td> <td rowspan="2">255</td> <td rowspan="2">215</td> <td rowspan="2">80</td> <td rowspan="2">232</td> <td rowspan="2">9.5</td> <td rowspan="2">M12</td> <td>60 (AWG 2/0)</td> </tr> <tr> <td>MR-DCL37K</td> <td>60 (AWG 2/0)</td> </tr> <tr> <td>MR-DCL30K-4</td> <td>135</td> <td>205</td> <td>200</td> <td>75</td> <td>175</td> <td>6.5</td> <td>M8</td> <td>22 (AWG 4)</td> </tr> <tr> <td>MR-DCL37K-4</td> <td>135</td> <td>225</td> <td>200</td> <td>80</td> <td>197</td> <td>7</td> <td>M8</td> <td>22 (AWG 4)</td> </tr> <tr> <td>MR-DCL45K-4</td> <td>135</td> <td>240</td> <td>200</td> <td>80</td> <td>212</td> <td>7.5</td> <td>M8</td> <td>38 (AWG 2)</td> </tr> <tr> <td>MR-DCL55K-4</td> <td>135</td> <td>260</td> <td>215</td> <td>80</td> <td>232</td> <td>9.5</td> <td>M8</td> <td>38 (AWG 2)</td> </tr> </tbody> </table>	Model	Variable dimensions [mm]					Mass [kg]	Terminal screw size	Wire size [mm <sup>2</sup> ] (Note 2)	W	D	H	W1	X	MR-DCL30K	135	255	215	80	232	9.5	M12	60 (AWG 2/0)	MR-DCL37K	60 (AWG 2/0)	MR-DCL30K-4	135	205	200	75	175	6.5	M8	22 (AWG 4)	MR-DCL37K-4	135	225	200	80	197	7	M8	22 (AWG 4)	MR-DCL45K-4	135	240	200	80	212	7.5	M8	38 (AWG 2)	MR-DCL55K-4	135	260	215	80	232	9.5	M8	38 (AWG 2)
Model	Variable dimensions [mm]					Mass [kg]	Terminal screw size	Wire size [mm <sup>2</sup> ] (Note 2)																																																							
	W	D	H	W1	X																																																										
MR-DCL30K	135	255	215	80	232	9.5	M12	60 (AWG 2/0)																																																							
MR-DCL37K								60 (AWG 2/0)																																																							
MR-DCL30K-4	135	205	200	75	175	6.5	M8	22 (AWG 4)																																																							
MR-DCL37K-4	135	225	200	80	197	7	M8	22 (AWG 4)																																																							
MR-DCL45K-4	135	240	200	80	212	7.5	M8	38 (AWG 2)																																																							
MR-DCL55K-4	135	260	215	80	232	9.5	M8	38 (AWG 2)																																																							

- Notes: 1. This indicates the maximum dimension. The dimension varies depending on the bending degree of the input/output lines.  
 2. The wire size is applicable when 600 V grade heat-resistant polyvinyl chloride insulated wire (HIV wires) is used.  
 3. When using FR-HEL-H15K, select a wire of 5.5 mm<sup>2</sup> (AWG 10) for MR-J4-700GF4/B4/A4, and 8 mm<sup>2</sup> (AWG 8) for MR-J4-11KGF4/B4/A4.

Servo Amplifiers  
Rotary Servo Motors  
Linear Servo Motors  
Direct Drive Motors  
Options/Peripheral Equipment  
LV5/Wires  
Product List  
Precautions

# Options/Peripheral Equipment

## Power Factor Improving AC Reactor (FR-HAL, FR-HAL-H)

**GF GF-RJ B B-RJ WB A A-RJ**

This boosts the power factor of servo amplifier and reduces the power supply capacity.

For MR-J4-GF/B/A

Servo amplifier model	Power factor improving AC reactor model (Note 2)	Fig.
MR-J4-10GF/B/A	FR-HAL-0.4K	A
MR-J4-20GF/B/A		
MR-J4-10GF1/B1/A1	FR-HAL-0.75K	
MR-J4-40GF/B/A		
MR-J4-20GF1/B1/A1	FR-HAL-1.5K	
MR-J4-60GF/B/A		
MR-J4-70GF/B/A	FR-HAL-2.2K	
MR-J4-40GF1/B1/A1		
MR-J4-100GF/B/A (3-phase power supply input)		
MR-J4-100GF/B/A (1-phase power supply input)		
MR-J4-200GF/B/A (3-phase power supply input)	FR-HAL-3.7K	B
MR-J4-200GF/B/A (1-phase power supply input)		
MR-J4-350GF/B/A	FR-HAL-7.5K	C
MR-J4-500GF/B/A	FR-HAL-11K	
MR-J4-700GF/B/A	FR-HAL-15K	
MR-J4-11KGF/B/A		
MR-J4-15KGF/B/A	FR-HAL-22K	D
MR-J4-22KGF/B/A	FR-HAL-30K	E
MR-J4-60GF4/B4/A4	FR-HAL-H1.5K	
MR-J4-100GF4/B4/A4	FR-HAL-H2.2K	
MR-J4-200GF4/B4/A4	FR-HAL-H3.7K	F
MR-J4-350GF4/B4/A4	FR-HAL-H7.5K	
MR-J4-500GF4/B4/A4	FR-HAL-H11K	G
MR-J4-700GF4/B4/A4	FR-HAL-H15K	
MR-J4-11KGF4/B4/A4		
MR-J4-15KGF4/B4/A4	FR-HAL-H22K	H
MR-J4-22KGF4/B4/A4	FR-HAL-H30K	

For MR-J4W2-B (Note 1)

Total output of rotary servo motors	Total continuous thrust of linear servo motors	Total output of direct drive motors	Power factor improving AC reactor model (Note 2)	Fig.
450 W or less	150 N or less	100 W or less	FR-HAL-0.75K	A
Over 450 W to 600 W	Over 150 N to 240 N	Over 100 W to 377 W	FR-HAL-1.5K	
Over 600 W to 1 kW	Over 240 N to 300 N	Over 377 W to 545 W	FR-HAL-2.2K	B
Over 1 kW to 2 kW	Over 300 N to 720 N	Over 545 W to 838 W	FR-HAL-3.7K	

For MR-J4W3-B (Note 1)

Total output of rotary servo motors	Total continuous thrust of linear servo motors	Total output of direct drive motors	Power factor improving AC reactor model (Note 2)	Fig.
450 W or less	150 N or less	-	FR-HAL-0.75K	A
Over 450 W to 600 W	Over 150 N to 240 N	378 W or less	FR-HAL-1.5K	
Over 600 W to 1 kW	Over 240 N to 300 N	-	FR-HAL-2.2K	B
Over 1 kW to 2 kW	Over 300 N to 450 N	-	FR-HAL-3.7K	

Notes: 1. Refer to "MR-J4W2-\_B MR-J4W3-\_B MR-J4W2-0303B6 Servo Amplifier Instruction Manual" for selecting a power factor improving AC reactor when combining multiple servo motors among the rotary servo motor, the linear servo motor or the direct drive motor.  
2. When using the power factor improving AC reactor, install one reactor for each servo amplifier.

### Connections

3-phase 200 V AC or  
3-phase 400 V AC

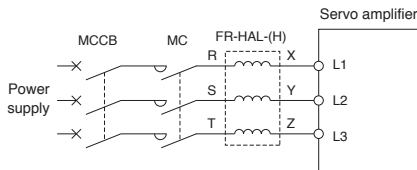

1-phase 200 V AC

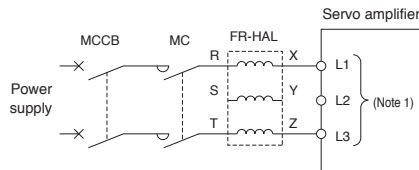

1-phase 100 V AC

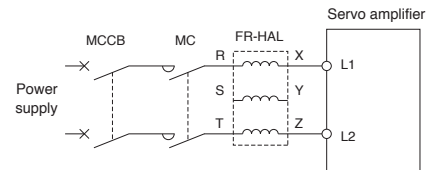

Notes: 1. Connect the power supply to L1 and L3 terminals. Do not connect anything to L2. The connections are different from MR-J3 series servo amplifiers. Be careful not to make a connection error when replacing MR-J3 with MR-J4.

Power Factor Improving AC Reactor (FR-HAL, FR-HAL-H)

GF GF-RJ B B-RJ WB A A-RJ

		Dimensions																																																						
A		<table border="1"> <thead> <tr> <th rowspan="2">Model</th> <th colspan="7">Variable dimensions [mm]</th> <th rowspan="2">Mass [kg]</th> <th rowspan="2">Terminal size</th> </tr> <tr> <th>W</th> <th>W1</th> <th>H</th> <th>D (Note 1)</th> <th>D1</th> <th>D2</th> <th>d</th> </tr> </thead> <tbody> <tr> <td>FR-HAL-0.4K</td> <td>104</td> <td>84</td> <td>99</td> <td>72</td> <td>51</td> <td>40</td> <td>M5</td> <td>0.6</td> <td>M4</td> </tr> <tr> <td>FR-HAL-0.75K</td> <td>104</td> <td>84</td> <td>99</td> <td>74</td> <td>56</td> <td>44</td> <td>M5</td> <td>0.8</td> <td>M4</td> </tr> <tr> <td>FR-HAL-1.5K</td> <td>104</td> <td>84</td> <td>99</td> <td>77</td> <td>61</td> <td>50</td> <td>M5</td> <td>1.1</td> <td>M4</td> </tr> </tbody> </table>								Model	Variable dimensions [mm]							Mass [kg]	Terminal size	W	W1	H	D (Note 1)	D1	D2	d	FR-HAL-0.4K	104	84	99	72	51	40	M5	0.6	M4	FR-HAL-0.75K	104	84	99	74	56	44	M5	0.8	M4	FR-HAL-1.5K	104	84	99	77	61	50	M5	1.1	M4
	Model	Variable dimensions [mm]							Mass [kg]		Terminal size																																													
W		W1	H	D (Note 1)	D1	D2	d																																																	
FR-HAL-0.4K	104	84	99	72	51	40	M5	0.6	M4																																															
FR-HAL-0.75K	104	84	99	74	56	44	M5	0.8	M4																																															
FR-HAL-1.5K	104	84	99	77	61	50	M5	1.1	M4																																															
B		<table border="1"> <thead> <tr> <th rowspan="2">Model</th> <th colspan="7">Variable dimensions [mm]</th> <th rowspan="2">Mass [kg]</th> <th rowspan="2">Terminal size</th> </tr> <tr> <th>W</th> <th>W1</th> <th>H</th> <th>D (Note 1)</th> <th>D1</th> <th>D2</th> <th>d</th> </tr> </thead> <tbody> <tr> <td>FR-HAL-2.2K</td> <td>115</td> <td>40</td> <td>115</td> <td>77</td> <td>71</td> <td>57</td> <td>M6</td> <td>1.5</td> <td>M4</td> </tr> <tr> <td>FR-HAL-3.7K</td> <td>115</td> <td>40</td> <td>115</td> <td>83</td> <td>81</td> <td>67</td> <td>M6</td> <td>2.2</td> <td>M4</td> </tr> <tr> <td>FR-HAL-5.5K</td> <td>115</td> <td>40</td> <td>115</td> <td>83</td> <td>81</td> <td>67</td> <td>M6</td> <td>2.3</td> <td>M4</td> </tr> </tbody> </table>								Model	Variable dimensions [mm]							Mass [kg]	Terminal size	W	W1	H	D (Note 1)	D1	D2	d	FR-HAL-2.2K	115	40	115	77	71	57	M6	1.5	M4	FR-HAL-3.7K	115	40	115	83	81	67	M6	2.2	M4	FR-HAL-5.5K	115	40	115	83	81	67	M6	2.3	M4
	Model	Variable dimensions [mm]							Mass [kg]		Terminal size																																													
W		W1	H	D (Note 1)	D1	D2	d																																																	
FR-HAL-2.2K	115	40	115	77	71	57	M6	1.5	M4																																															
FR-HAL-3.7K	115	40	115	83	81	67	M6	2.2	M4																																															
FR-HAL-5.5K	115	40	115	83	81	67	M6	2.3	M4																																															
C		<table border="1"> <thead> <tr> <th rowspan="2">Model</th> <th colspan="7">Variable dimensions [mm]</th> <th rowspan="2">Mass [kg]</th> <th rowspan="2">Terminal size</th> </tr> <tr> <th>W</th> <th>W1</th> <th>H</th> <th>D (Note 1)</th> <th>D1</th> <th>D2</th> <th>d</th> </tr> </thead> <tbody> <tr> <td>FR-HAL-7.5K</td> <td>130</td> <td>50</td> <td>135</td> <td>100</td> <td>98</td> <td>86</td> <td>M6</td> <td>4.2</td> <td>M5</td> </tr> <tr> <td>FR-HAL-11K</td> <td>160</td> <td>75</td> <td>164</td> <td>111</td> <td>109</td> <td>92</td> <td>M6</td> <td>5.2</td> <td>M6</td> </tr> <tr> <td>FR-HAL-15K</td> <td>160</td> <td>75</td> <td>167</td> <td>126</td> <td>124</td> <td>107</td> <td>M6</td> <td>7.0</td> <td>M6</td> </tr> </tbody> </table>								Model	Variable dimensions [mm]							Mass [kg]	Terminal size	W	W1	H	D (Note 1)	D1	D2	d	FR-HAL-7.5K	130	50	135	100	98	86	M6	4.2	M5	FR-HAL-11K	160	75	164	111	109	92	M6	5.2	M6	FR-HAL-15K	160	75	167	126	124	107	M6	7.0	M6
	Model	Variable dimensions [mm]							Mass [kg]		Terminal size																																													
W		W1	H	D (Note 1)	D1	D2	d																																																	
FR-HAL-7.5K	130	50	135	100	98	86	M6	4.2	M5																																															
FR-HAL-11K	160	75	164	111	109	92	M6	5.2	M6																																															
FR-HAL-15K	160	75	167	126	124	107	M6	7.0	M6																																															

Notes: 1. This indicates the maximum dimension. The dimension varies depending on the bending degree of the input/output lines.

Servo Amplifiers  
Rotary Servo Motors  
Linear Servo Motors  
Direct Drive Motors  
Options/Peripheral Equipment  
LV5/Wires  
Product List  
Precautions

## Power Factor Improving AC Reactor (FR-HAL, FR-HAL-H)

GF GF-RJ B B-RJ A A-RJ

### Dimensions

**D**

Earth (ground) terminal  
Wire the earthing (grounding) cable to the earth (ground) terminal

Installation hole for 4-M6  
(near right side, varnish removed)

MAX D (Note 1)

Model	Variable dimensions [mm]						Mass [kg]	Terminal size
	W	W1	H	D (Note 1)	D1	D2		
FR-HAL-22K	185	75	150	158	100	87	9.0	M8
FR-HAL-30K	185	75	150	168	100	87	9.7	M10

**E**

Installation hole for 4-d varnish removed  
(front, rear)

Terminal layout  
R|X|S|Y|T|Z

Earth (ground) terminal  
Wire the earthing (grounding) cable to the earth (ground) terminal

Terminal block (with cover)

Model	Variable dimensions [mm]								Mass [kg]	Terminal size
	W	W1	W2	H	D (Note 1)	D1	D2	d		
FR-HAL-H1.5K	135	120	8	115	59	59.6	45	M4	1.5	M3.5
FR-HAL-H2.2K	135	120	8	115	59	59.6	45	M4	1.5	M3.5
FR-HAL-H3.7K	135	120	8	115	69	70.6	57	M4	2.5	M3.5

**F**

Installation hole for 4-d varnish removed  
(front, rear)

Terminal layout  
R|X|S|Y|T|Z

Earth (ground) terminal  
Wire the earthing (grounding) cable to the earth (ground) terminal

Terminal block (with cover)

Model	Variable dimensions [mm]								Mass [kg]	Terminal size
	W	W1	W2	H	D (Note 1)	D1	D2	d		
FR-HAL-H7.5K	160	145	8	150	91	91	75	M4	5.0	M4

Notes: 1. This indicates the maximum dimension. The dimension varies depending on the bending degree of the input/output lines.



Power Factor Improving AC Reactor (FR-HAL, FR-HAL-H)

GF GF-RJ B B-RJ A A-RJ

**Dimensions**

**G**

Installation hole for 4-d  
Varnish removed  
(front, rear)

Terminal layout  
R | X | S | Y | T | Z

Earth (ground) terminal  
Wire the earthing (grounding) cable to the earth (ground) terminal

Terminal block (2)  
(with cover)

W, W1, W2, D, D1, D2, H

Model	Variable dimensions [mm]								Mass [kg]	Terminal size
	W	W1	W2	H	D (Note 1)	D1	D2	d		
FR-HAL-H11K	160	145	8	146	91	91	75	M4	6.0	M5
FR-HAL-H15K	220	200	10	195	105	90	70	M5	9.0	M5

---

**H**

Installation hole for 4-d  
(Varnish removed  
(front, rear))

Terminal layout  
R | X | S | Y | T | Z

Earth (ground) terminal  
Wire the earthing (grounding) cable to the earth (ground) terminal

Terminal block  
(with cover)

W, W1, W2, MAX D, D1, D2, H

Model	Variable dimensions [mm]								Mass [kg]	Terminal size
	W	W1	W2	H	D (Note 1)	D1	D2	d		
FR-HAL-H22K	220	200	10	212	155	90	70	M5	9.5	M8
FR-HAL-H30K	220	200	10	212	153	96	75	M5	11	M8

Notes: 1. This indicates the maximum dimension. The dimension varies depending on the bending degree of the input/output lines.

Servo Amplifiers

Rotary Servo Motors

Linear Servo Motors

Direct Drive Motors

Options/Peripheral Equipment

LVS/Wires

Product List

Precautions

## AC Reactor (MR-AL)

**B** **B-RJ** **B-RJ100**

Power regeneration converter unit model	AC reactor model	
MR-CV11K	MR-AL-11K	A
MR-CV18K	MR-AL-18K	
MR-CV30K	MR-AL-30K	
MR-CV37K	MR-AL-37K	
MR-CV45K	MR-AL-45K	
MR-CV55K	MR-AL-55K	

Power regeneration converter unit model	AC reactor model	
MR-CV11K4	MR-AL-11K4	A
MR-CV18K4	MR-AL-18K4	
MR-CV30K4	MR-AL-30K4	
MR-CV37K4	MR-AL-37K4	
MR-CV45K4	MR-AL-45K4	
MR-CV55K4	MR-AL-55K4	
MR-CV75K4	MR-AL-75K4	
MR-CV55K4 (parallel drive)	MR-AL-55K4-L (Note 1)	B

### Connections

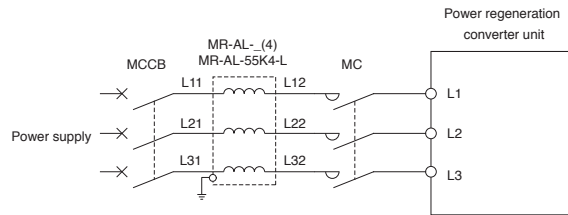

### Dimensions

[Unit: mm]

A

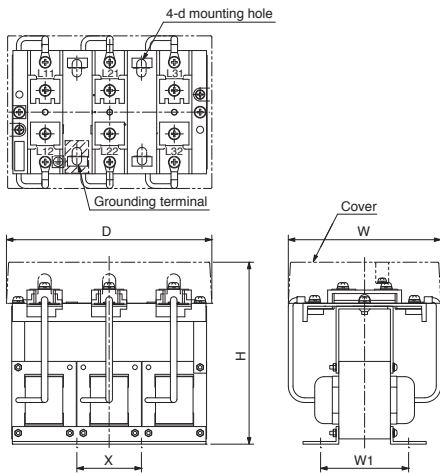

Model	Variable dimensions [mm]						Mass [kg]	Terminal screw
	W	D	H	W1	X	d		
MR-AL-11K	145	175	155	75	55	M6	3.7	M5
MR-AL-18K	145	175	155	105	55	M6	5.3	M6
MR-AL-30K	145	175	155	110	55	M6	6.1	M6
MR-AL-37K	150	215	175	110	70	M6	8.6	M6
MR-AL-45K	160	215	175	120	70	M6	9.7	M6
MR-AL-55K	230	220	192	120	200	M8	11.5	M10
MR-AL-11K4	145	175	155	75	55	M6	3.7	M5
MR-AL-18K4	145	175	155	105	55	M6	5.3	M6
MR-AL-30K4	145	175	155	110	55	M6	6.0	M6
MR-AL-37K4	150	215	175	110	70	M6	8.5	M6
MR-AL-45K4	160	215	175	120	70	M6	9.8	M6
MR-AL-55K4	230	220	210	120	200	M8	10.5	M6
MR-AL-75K4	230	250	215	143	230	M8	13.0	M6

B

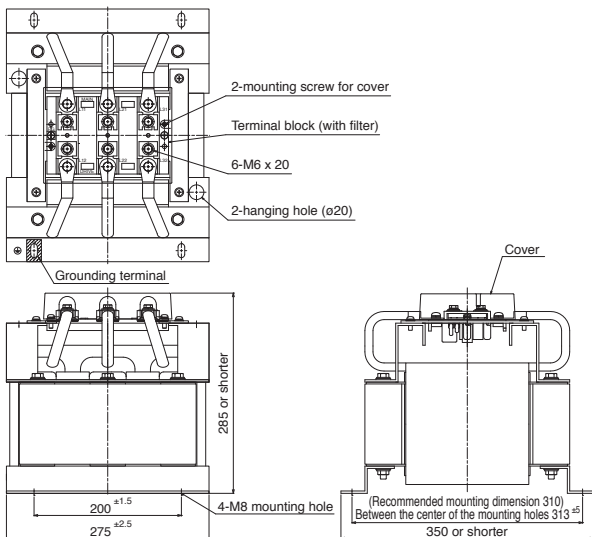

Mounting screw size  
M8

Mass: 56 kg

Notes: 1. Use MR-AL-55K4-L for parallel drive. MR-AL-55K4 cannot be used.

## Drive System Sizing Software MELSOFT Motorizer

MELSOFT

## Specifications

Item	Description
Types of motor/drive	Servo, Inverter, Sensorless servo
Types of load mechanism	Ball screw, Rack and pinion, Roll feed, Rotary table, Cart, Elevator/Hoist, Conveyor, Fan, Pump, Crank, Generic (Rotary), Generic (Linear), Linear servo
Types of transmission mechanism	Coupling, External gear reducer, V belt and pulley, Toothed belt/roller chain
Operation pattern	Constant speed/Pause, Acceleration/Deceleration, Trapezoid, Triangle, Speed CSV File, MELSOFT GX LogViewer file
Types of input support of moment of inertia calculation function	Solid cylinder, Hollow cylinder, Disk, Rectangular solid, Truncated cone, Sphere, Generic
Sizing results	Result, Motor type, Power supply voltage, Motor, Motor capacity, Drive, Drive capacity, Effective torque, Torque effective load rate, Peak torque, Peak load rate, Effective torque at stop, Effective load rate at stop, Motor output, Motor output rate, Maximum speed, Maximum speed rate, Maximum load inertia moment, Inertia moment ratio, Regenerative power, Regenerative load ratio, Regenerative option, Maximally increased torque, Rated speed, Brake, Oil seal, Structure specification, Graph of Motor side speed/Motor side torque/Motor output
Printing of output of results	Prints load mechanism, transmission mechanism, operation pattern, and sizing results.
Data saving	Load mechanism, transmission mechanism, operation pattern, motor selection, drive selection, and sizing results are saved with a file name.

Operating environment (Note 1, 2)

Item	Description	
OS	Microsoft® Windows® 11 Microsoft® Windows® 10 (64-bit/32-bit)	
.NET Framework	.NET Framework 4.6 or later	
CPU (recommended)	Windows® 11	2 or more cores on a compatible 64-bit processor or System on a Chip (SoC)
	Windows® 10	Desktop PC: Intel® Celeron® processor 2.4 GHz or more Laptop PC: Intel® Pentium® processor 1.9 GHz or more
Memory (recommended)	Windows® 11	4 GB or more (64-bit OS)
	Windows® 10	1 GB or more (32-bit OS), 2 GB or more (64-bit OS)
Free hard disk space	For installation: 1 GB or more free hard disk capacity For operation: 512 MB or more free virtual memory capacity	
Monitor	Resolution 1024 × 768 or more (XGA) Compatible with above personal computers	

Notes: 1. This software may not run correctly on some personal computers.  
2. Surrogate pair characters and environment dependent characters are not available.

Servo Amplifiers

Rotary Servo Motors

Linear Servo Motors

Direct Drive Motors

Options/Peripheral Equipment

LV5/Wires

Product List

Precautions

# Options/Peripheral Equipment

## Servo Engineering Software MELSOFT MR Configurator2 (SW1DNC-MRC2-E) <sup>(Note 1)</sup>

MELSOFT

MR Configurator2 can be obtained by either of the following:

- Purchase MR Configurator2 alone.
- Purchase GX Works3 or MT Works2: MR Configurator2 is included in GX Works3 and MT Works2 with software version 1.34L or later.

### Specification <sup>(Note 2)</sup>

Item	Description
Project	New/Open/Save/Save As/Delete Project, Read Other Format, Write Other Format, System Setting, Print
Parameter	Parameter Setting, Network Parameter, Axis Name Setting, Parameter Converter
Safety	Safety parameter setting, Change password, Initialize password
Positioning-data	Point Table, Program, Indirect Addressing, Cam Data
Monitor	Display All, I/O Monitor, Graph, ABS Data Display, Object Monitor
Diagnosis	Alarm Display, Alarm Onset Data, Drive recorder, No Motor Rotation, System Configuration, Life Diagnosis, Machine Diagnosis, Linear Diagnosis, Fully Closed Loop Diagnosis, Gear Failure Diagnosis, Encoder Communication Diagnosis
Test Operation	JOG Operation, Positioning Operation, Motor-Less Operation, DO Forced Output, Program Operation, Single-Step Feed, Test Operation Information
Adjustment	One-Touch Tuning, Tuning, Multi-Axis Tuning, Machine Analyzer, Advanced Gain Search
Others	Servo Assistant, Update Parameter Setting Range, Machine Unit Conversion Setting, Axis Label Name Settings, Add-ons, Switch Display Language, Help

Notes: 1. Each servo amplifier is supported by MR Configurator2 with the following or later software version.

• MR-J4-GF: 1.51D • MR-J4-B/MR-J4-A: 1.09K

2. Supported items vary depending on the servo amplifiers. Refer to "MR Configurator2 SW1DNC-MRC2-E Installation Guide" for details.

### Operating environment <sup>(Note 1, 3)</sup>

Components	Description
OS	Microsoft® Windows® 11 Education Microsoft® Windows® 11 Enterprise Microsoft® Windows® 11 Pro Microsoft® Windows® 11 Home Microsoft® Windows® 10 Education Microsoft® Windows® 10 Enterprise Microsoft® Windows® 10 Pro Microsoft® Windows® 10 Home Microsoft® Windows® 10 IoT Enterprise 2016 LTSC <sup>(Note 2)</sup> Microsoft® Windows® 10 IoT Enterprise 2019 LTSC <sup>(Note 2)</sup>
CPU (recommended)	Windows® 11 2 or more cores on a compatible 64-bit processor or System on a Chip (SoC)
	Windows® 10 Desktop PC: Intel® Celeron® processor 2.8 GHz or more Laptop PC: Intel® Pentium® M processor 1.7 GHz or more
Memory (recommended)	Windows® 11 4 GB or more (64-bit OS)
	Windows® 10 1 GB or more (32-bit OS), 2 GB or more (64-bit OS)
Free hard disk space	1.5 GB or more
Monitor	Resolution 1024 × 768 or more, 16-bit high color, Compatible with above personal computers
USB cable	MR-J3USBCBL3M
Ethernet cable	Cable type: Category 5e or higher, (double shielded/STP) straight cable Standard: IEEE802.3 (1000BASE-T) or ANSI/TIA/EIA-568-B (Category 5e) Connector: RJ-45 connector with shield

Notes: 1. This software may not run correctly on some personal computers.

2. This software is supported by 64-bit OS only.

3. Surrogate pair characters and environment dependent characters are not available.

## Unit Conversion Table

Quantity	SI (metric) unit	U.S. customary unit
Mass	1 [kg]	2.2046 [lb]
Length	1 [mm]	0.03937 [in]
Torque	1 [N·m]	141.6 [oz·in]
Moment of inertia	1 [( $\times 10^{-4}$ kg·m <sup>2</sup> )]	5.4675 [oz·in <sup>2</sup> ]
Load (thrust load/axial load)	1 [N]	0.2248 [lbf]
Temperature	n [°C]	$n \times 9/5 + 32$ [°F]

Servo Amplifiers

Rotary Servo Motors

Linear Servo Motors

Direct Drive Motors

Options/Peripheral  
Equipment

LV5/Wires

Product List

Precautions

## Options/Peripheral Equipment

MEMO

# 6

## Low-Voltage Switchgear/Wires

	Servo amplifier							●: Applicable
	GF	GF-RJ	B	B-RJ	WB	A	A-RJ	
Features of Low-Voltage Switchgear	●	●	●	●	●	●	●	.....6-1
Wires, Molded-Case Circuit Breakers and Magnetic Contactors	●	●	●	●	●	●	●	.....6-5
Type E Combination Motor Controller	●	●	●	●	●	●	●	.....6-9
Selection Example in HIV Wires for Servo Motors	●	●	●	●	●	●	●	.....6-10

**GF** MR-J4-GF   **GF-RJ** MR-J4-GF-RJ   **B** MR-J4-B/MR-J4-DU\_B   **B-RJ** MR-J4-B-RJ/MR-J4-DU\_B-RJ   **B-RJ100** MR-J4-DU\_B4-RJ100

**WB** MR-J4W2-B/MR-J4W3-B   **A** MR-J4-A/MR-J4-DU\_A   **A-RJ** MR-J4-A-RJ/MR-J4-DU\_A-RJ

\* Note that low-voltage switchgears/wires necessary for servo amplifiers with special specification are the same as those for standard servo amplifiers. Refer to the servo amplifiers with the same rated capacity.

# Low-Voltage Switchgear/Wires

## Mitsubishi Electric Molded Case Circuit Breakers and Earth Leakage Circuit Breakers WS-V Series

"WS-V Series" is our main series of circuit breakers in the industry's smallest class with high breaking performance enabled by a new breaking technology. The new WS-V series circuit breakers have enhanced usability with further standardization of accessory parts, compliance with the global standards, and consideration to environmental and energy-saving issues.

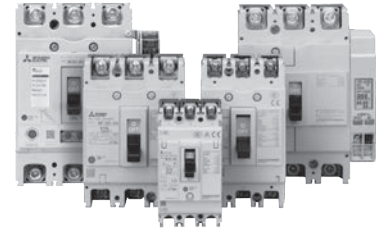

### Features

The industry's smallest class of 54 mm width for 32 A/63 A frames realized by the new breaking technology "arc run breaking method"<sup>\*1</sup>. The compact breakers contribute to a size reduction of the cabinets and the machines while keeping the breaking performance.

\*1. Adopted for the F Style 32 A/63 A frames

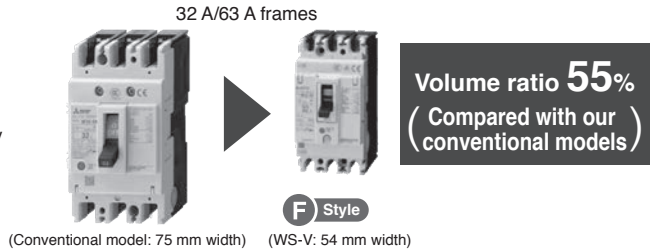
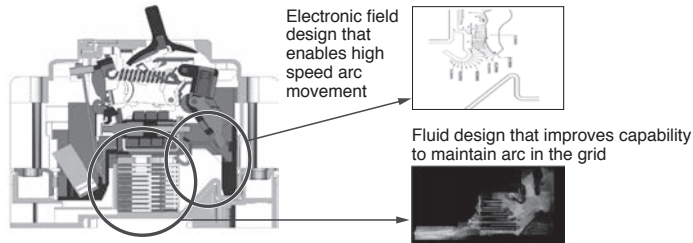

When multiple units are installed on a branch circuit, the width is significantly reduced.

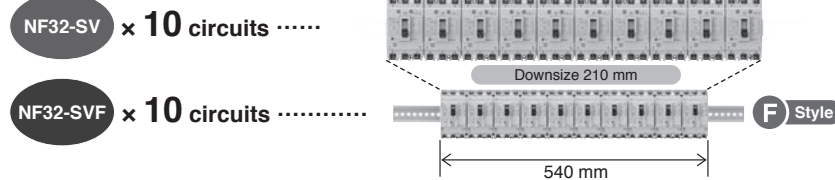

Added the spring clamp type to the product lines



NF32-CVF NV32-CVF



CP30-BA



NF63-CVF NV63-CVF  
NF32-SVF NV32-SVF  
NF63-SVF NV63-SVF  
NF50-SVFU NV50-SVFU



NF50-KC NV50-KC

The first lineup in Japan\* that covers a rated current of up to 50 A.  
\* Based on the research of Mitsubishi Electric as of January 2023.

Spring clamp terminals do not use terminal screws and have the following features.	
<b>Less wiring time</b>	<ul style="list-style-type: none"> <li>The wiring time is reduced.</li> <li>Preparing and mounting a terminal cover are unnecessary.</li> </ul>
<b>Stable quality</b>	<ul style="list-style-type: none"> <li>Screw fastening skills are unnecessary.</li> <li>The risk of loosening terminal screws due to vibration, shock, and long-term use is eliminated.</li> </ul>
<b>Less maintenance</b>	<ul style="list-style-type: none"> <li>Screw tightening is unnecessary at inspection and delivery of the cabinet and machine.</li> </ul>



### Mitsubishi Electric Magnetic Motor Starters and Magnetic Contactors MS-T Series

The flagship series realizing further down-sizing

The MS-T series is smaller than ever, enabling more compact control panel. The MS-T series is suitable for MELSERVO-J4 series as well as other Mitsubishi Electric FA equipment. In addition, the MS-T complies with a variety of global standards, supporting the global use.



S-T10

#### Features

##### Down-sizing

**Just 36 mm wide for 10 A-frame type!**

General-purpose magnetic contactor with smallest width\* in the industry.

The width of MS-T series is reduced by 32% as compared to the prior MS-N series, enabling a more compact panel.

\*Based on Mitsubishi Electric research as of March 2016 in the general-purpose magnetic contactor industry for 10 A-frame class.

[Unit: mm]

Frame size		11 A	13 A		20 A	25 A	32 A
Conventional MS-N series	Front view						None
		S-N10	S-N11 (Auxiliary 1-pole)	S-N12 (Auxiliary 2-pole)	S-N20	S-N25	
New MS-T series	Front view						
		S-T10	S-T12 (Auxiliary 2-pole)	S-T20	S-T25	S-T32	

Frame size		35 A	50 A	65 A	80 A	100 A
MS-N series	Front view					
		S-N35	S-N50	S-N65	S-N80	S-N95
New MS-T series	Front view					
		S-T35	S-T50	S-T65	S-T80	S-T100

#### Standardization

##### Covers provided as standard equipment (Target frame: 10 AF to 50 AF)

Terminal cover and auxiliary contact unit covers are provided as standard equipment. Not only ensuring your safety, but also saving you time and cost of selecting and purchasing the covers separately.

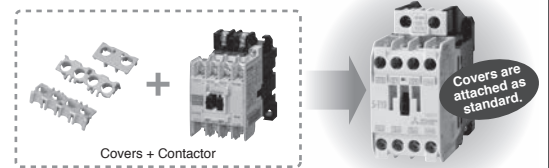

##### Wide-ranged operation coil rating (Target frame: 10 AF to 35 AF)

The prior series had 13 types of the operation coil rating. Owing to the wide-ranged operation coil rating, the number of the rating types for the MS-T series is reduced to seven types, making it easier to select as compared to the prior model.

Consolidating the number of the produced coils type allows not just the reduction of customer storage, but also shortening of delivery time.

Coil designation	Rated voltage [V]		Coil designation	Rated voltage [V]
	50 Hz	60 Hz		50 Hz/60 Hz
AC24 V	24	24	AC24 V	24
AC48 V	48 to 50	48 to 50	AC48 V	48 to 50
AC100 V	100	100 to 110	AC100 V	100 to 127
AC120 V	110 to 120	115 to 120	AC200 V	200 to 240
AC127 V	125 to 127	127	AC300 V	260 to 300
AC200 V	200	200 to 220	AC400 V	380 to 440
AC220 V	208 to 220	220	AC500 V	460 to 550
AC230 V	220 to 240	230 to 240		
AC260 V	240 to 260	260 to 280		
AC380 V	346 to 380	380		
AC400 V	380 to 415	400 to 440		
AC440 V	415 to 440	460 to 480		
AC500 V	500	500 to 550		

\* The conventional seven types are available for the 50 A and larger frames.

Servo Amplifiers  
 Rotary Servo Motors  
 Linear Servo Motors  
 Direct Drive Motors  
 Options/Peripheral Equipment  
 LVSWires  
 Product List  
 Precautions

# Low-Voltage Switchgear/Wires

Capable of direct drive with transistor output of programmable controller, etc. (Target frame: 13 AF to 32 AF DC-operated models)

The adopted high-efficiency polarized electromagnet greatly reduces the coil power consumption, and enables all models to be directly driven with a DC 24 V, 0.1 A rating transistor output. (DC 24 V coil)

	Conventional Model	New Model	Lowering Rate
13 A Frame (Coil: DC 12/24 V)*	7 W	2.2 W	69%
20 A Frame (Coil: DC 12/24 V)	9 W	2.2 W	76%
32 A Frame (Coil: DC 12/24 V)	-	2.2 W	-

\*DC 48 V to DC 220 V: 3.3 W

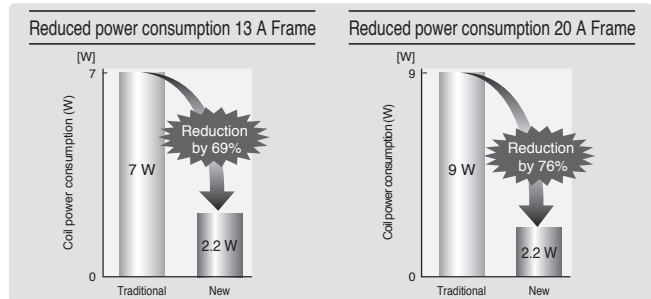

## Safety & Quality

Terminal cover with finger protection function (Target frame: 10 AF to 50 AF)

In addition to the Magnetic Contactor, a terminal cover has been provided as a standard for the thermal, magnetic relay and auxiliary contact unit options. The finger protection function prevents electric shocks and increases safety during maintenance and inspections.

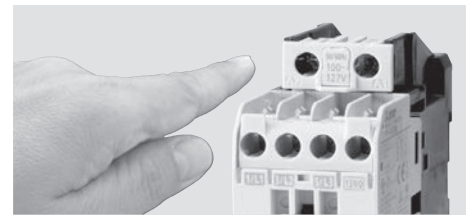

A light touch (Target frame: All S-T Series)

The MS-T Series' auxiliary contacts can operate with load as light as 20 V 3 mA making it suitable for direct control/operation from a programmable controller output.



## Smart wiring

Smart design means Smart wiring (Target frame: 10 AF to 50 AF)

The integrated terminal covers have an additional benefit in that they act as a guide to improve wiring efficiency but also retain the terminal screw in place: no mislaying the screw, no dropping it or having trouble reinserting it into the terminal block just fast efficient wiring. Fast wiring terminals (model name with suffix "BC") are also available to further improve wiring efficiency, workability and hence productivity.

Image of Fast wiring terminals (BC type)

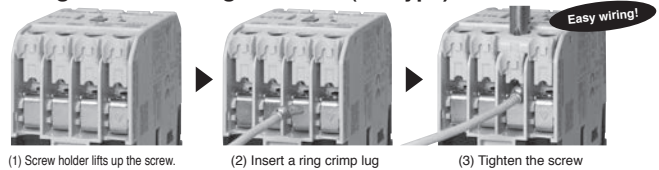

Added the spring clamp type to the product lines



Spring clamp terminals do not use terminal screws and have the following features.

Less wiring time

- The wiring time is reduced.
- Preparing and mounting a terminal cover are unnecessary.

Stable quality

- Screw fastening skills are unnecessary.
- The risk of loosening terminal screws due to vibration, shock, and long-term use is eliminated.

Less maintenance

- Screw tightening is unnecessary at inspection and delivery of the cabinet and machine.

MEMO

Servo Amplifiers

Rotary Servo Motors

Linear Servo Motors

Direct Drive Motors

Options/Peripheral  
Equipment

**LVS/Wires**

Product List

Precautions

# Low-Voltage Switchgear/Wires

## Wires, Molded-Case Circuit Breakers and Magnetic Contactors

The following are examples of wire sizes when 600 V grade heat-resistant polyvinyl chloride insulated wires (HIV wires) are used. The wire size for U, V, W, and E varies depending on the servo motor. Refer to "Selection Example in HIV Wires for Servo Motors" in this catalog for details on wires for each servo motor.

Example of Selection for MR-J4-GF/MR-J4-B/MR-J4-A

**GF** **GF-RJ** **B** **B-RJ** **A** **A-RJ**

Servo amplifier model	Molded-case circuit breaker <small>(Note 5, 6)</small>	Magnetic contactor <small>(Note 3, 6)</small>	Wire size [mm <sup>2</sup> ] <small>(Note 5)</small>			
			L1, L2, L3, ⊕	L11, L21	P+, C <small>(Note 1)</small>	U, V, W, E
MR-J4-10GF(1)/B(1)/A(1)	30 A frame 5 A (30 A frame 5 A)	S-T10	2 (AWG 14)	1.25 to 2 (AWG 16 to 14)	2 (AWG 14)	AWG 18 to 14 <small>(Note 4)</small>
MR-J4-20GF/B/A	30 A frame 5 A (30 A frame 5 A)	S-T10				
MR-J4-20GF1/B1/A1	30 A frame 10 A (30 A frame 10 A)	S-T10				
MR-J4-40GF/B/A	30 A frame 10 A (30 A frame 5 A)	S-T10				
MR-J4-40GF1/B1/A1	30 A frame 15 A (30 A frame 10 A)	S-T10				
MR-J4-60GF/B/A	30 A frame 15 A (30 A frame 10 A)	S-T10				
MR-J4-70GF/B/A	30 A frame 15 A (30 A frame 10 A)	S-T10				
MR-J4-100GF/B/A (3-phase power input)	30 A frame 15 A (30 A frame 10 A)	S-T10				
MR-J4-100GF/B/A (1-phase power input)	30 A frame 15 A (30 A frame 15 A)	S-T10				
MR-J4-200GF/B/A (3-phase power input)	30 A frame 20 A (30 A frame 20 A)	S-T21				
MR-J4-200GF/B/A (1-phase power input)	30 A frame 20 A (30 A frame 20 A)	S-T21				
MR-J4-350GF/B/A	30 A frame 30 A (30 A frame 30 A)	S-T21				
MR-J4-500GF/B/A <small>(Note 2)</small>	50 A frame 50 A (50 A frame 50 A)	S-T35	5.5 (AWG 10)			2 to 5.5 (AWG 14 to 10)
MR-J4-700GF/B/A <small>(Note 2)</small>	100 A frame 75 A (60 A frame 60 A)	S-T50	8 (AWG 8)			2 to 8 (AWG 14 to 8)
MR-J4-11KGF/B/A <small>(Note 2)</small>	100 A frame 100 A (100 A frame 100 A)	S-T50	14 (AWG 6)		3.5 (AWG 12)	5.5 (AWG 10), 8 (AWG 8), 14 (AWG 6)
MR-J4-15KGF/B/A <small>(Note 2)</small>	125 A frame 125 A (125 A frame 125 A)	S-T65	22 (AWG 4)		5.5 (AWG 10)	8 (AWG 8), 22 (AWG 4)
MR-J4-22KGF/B/A <small>(Note 2)</small>	225 A frame 175 A (225 A frame 175 A)	S-T100	38 (AWG 2)			38 (AWG 2)
MR-J4-60GF4/B4/A4	30 A frame 5 A (30 A frame 5 A)	S-T10	2 (AWG 14)	2 (AWG 14)		AWG 16 to 14 <small>(Note 4)</small>
MR-J4-100GF4/B4/A4	30 A frame 10 A (30 A frame 5 A)	S-T10	2 (AWG 14)			
MR-J4-200GF4/B4/A4	30 A frame 15 A (30 A frame 10 A)	S-T10	2 (AWG 14)			
MR-J4-350GF4/B4/A4	30 A frame 20 A (30 A frame 15 A)	S-T21	2 (AWG 14)			
MR-J4-500GF4/B4/A4 <small>(Note 2)</small>	30 A frame 20 A (30 A frame 20 A)	S-T21	2 (AWG 14)			
MR-J4-700GF4/B4/A4 <small>(Note 2)</small>	30 A frame 30 A (30 A frame 30 A)	S-T21	3.5 (AWG 12)			
MR-J4-11KGF4/B4/A4 <small>(Note 2)</small>	50 A frame 50 A (50 A frame 50 A)	S-T35	5.5 (AWG 10)			
MR-J4-15KGF4/B4/A4 <small>(Note 2)</small>	60 A frame 60 A (60 A frame 60 A)	S-T35	8 (AWG 8)			
MR-J4-22KGF4/B4/A4 <small>(Note 2)</small>	100 A frame 100 A (100 A frame 100 A)	S-T50	14 (AWG 6)			
						5.5 (AWG 10), 8 (AWG 8), 14 (AWG 6)

- Notes: 1. Keep the wire length to the regenerative option within 5 m.  
 2. When connecting the wires to the terminal blocks, be sure to use the screws attached to the terminal blocks.  
 3. Be sure to use a magnetic contactor with an operation delay time of 80 ms or less. The operation delay time is the time interval from current being applied to the coil until closure of contacts.  
 4. The wire size shows applicable size for the servo amplifier connector.  
 5. When complying with IEC/EN/UL/CSA standard, refer to relevant Servo Amplifier Instruction Manual for details.  
 When using a power improving reactor, use a molded-case circuit breaker listed in the brackets.  
 6. Install one molded-case circuit breaker and one magnetic contactor for each servo amplifier.

### Wires, Molded-Case Circuit Breakers and Magnetic Contactors

The following are examples of wire sizes when 600 V grade heat-resistant polyvinyl chloride insulated wires (HIV wires) are used. The wire size for U, V, W, and E varies depending on the servo motor. Refer to "Selection Example in HIV Wires for Servo Motors" in this catalog for details on wires for each servo motor.

Example of Selection for Combination of MR-CV\_ and MR-J4-DU\_B

**B B-RJ**

Power regeneration converter unit model (Note 2)	Molded-case circuit breaker (Note 3, 4)	Magnetic contactor (Note 1, 3)	Wire size [mm <sup>2</sup> ] (Note 4, 5)	
			L1, L2, L3, ⊕	L11, L21
MR-CV11K	50 A frame 50 A	S-T35	8 (AWG 8)	1.25 to 2 (AWG 16 to 14)
MR-CV18K	100 A frame 100 A	S-T65	22 (AWG 4)	
MR-CV30K	225 A frame 150 A	S-N125	38 (AWG 2)	
MR-CV37K	225 A frame 175 A	S-N125	60 (AWG 2/0)	
MR-CV45K	225 A frame 225 A	S-N150	60 (AWG 2/0)	
MR-CV55K	400 A frame 300 A	S-N220	80 (AWG 3/0)	
MR-CV11K4	30 A frame 30 A	S-T21	5.5 (AWG 10)	
MR-CV18K4	50 A frame 50 A	S-T35	8 (AWG 8)	
MR-CV30K4	100 A frame 80 A	S-T65	14 (AWG 6)	
MR-CV37K4	100 A frame 100 A	S-T80	22 (AWG 4)	
MR-CV45K4	125 A frame 125 A	S-T100	22 (AWG 4)	
MR-CV55K4	225 A frame 150 A	S-N125	38 (AWG 2)	
MR-CV75K4	225 A frame 200 A	S-N150	60 (AWG 2/0)	

Example of Selection for Combination of MR-CV\_ and MR-J4-DU\_B4-RJ100

**B-RJ100**

Servo motor model (Note 2)	Drive unit model (Note 2)	Converter unit model (Note 2)	Molded-case circuit breaker (Note 3, 4)	Magnetic contactor (Note 1, 3)	Wire size [mm <sup>2</sup> ] (Note 4)	
					L1, L2, L3, ⊕	L11, L21
HG-JR110K24W0C	MR-J4-DU55KB4-RJ100	MR-CV55K4	225 A frame 175 A	S-N150	38 (AWG 2)	2 (AWG 14)
HG-JR150K24W0C	MR-J4-DU45KB4-RJ100	MR-CV55K4	225 A frame 125 A	S-T100	38 (AWG 2)	2 (AWG 14)
HG-JR180K24W0C	MR-J4-DU45KB4-RJ100	MR-CV55K4	225 A frame 150 A	S-N125	38 (AWG 2)	2 (AWG 14)
HG-JR200K24W0C	MR-J4-DU55KB4-RJ100	MR-CV55K4	225 A frame 175 A	S-N150	38 (AWG 2)	2 (AWG 14)
HG-JR220K24W0C	MR-J4-DU55KB4-RJ100	MR-CV55K4	225 A frame 175 A	S-N150	38 (AWG 2)	2 (AWG 14)

- Notes: 1. Be sure to use a magnetic contactor with an operation delay time of 80 ms or less. The operation delay time is the time interval from current being applied to the coil until closure of contacts.  
 2. When connecting the wires to the terminal blocks, be sure to use the screws attached to the terminal blocks.  
 3. Install one molded-case circuit breaker and one magnetic contactor for each power regeneration converter unit.  
 4. When complying with IEC/EN/UL/CSA standard, refer to "MR-CV\_ MR-CR55K\_ MR-J4-DU\_B\_(-RJ) MR-J4-DU\_A\_(-RJ) Instruction Manual".  
 5. Wires are selected based on the highest rated current among the servo motors to be combined.

Servo Amplifiers

Rotary Servo Motors

Linear Servo Motors

Direct Drive Motors

Options/Peripheral Equipment

LVS/Wires

Product List

Precautions

# Low-Voltage Switchgear/Wires

Example of Selection for Combination of MR-CR\_ and MR-J4-DU\_B/MR-J4-DU\_A

**B** **B-RJ** **A** **A-RJ**

Resistance regeneration converter unit model <sup>(Note 2)</sup>	Drive unit model	Molded-case circuit breaker <sup>(Note 3, 4)</sup>	Magnetic contactor <sup>(Note 1, 3)</sup>	Wire size [mm <sup>2</sup> ] <sup>(Note 4)</sup>		
				L1, L2, L3, ⊕	L11, L21	P2, C
MR-CR55K	MR-J4-DU30KB/A	225 A frame 175 A (225 A frame 150 A)	S-N150	38 (AWG 2)	1.25 to 2 (AWG 16 to 14)	5.5 (AWG 10)
	MR-J4-DU37KB/A	225 A frame 225 A (225 A frame 175 A)	S-N180	60 (AWG 2/0)		
MR-CR55K4	MR-J4-DU30KB4/A4	100 A frame 100 A (100 A frame 80 A)	S-T65	22 (AWG 4)		
	MR-J4-DU37KB4/A4	125 A frame 125 A (100 A frame 100 A)	S-T80	22 (AWG 4)		
	MR-J4-DU45KB4/A4	225 A frame 150 A (125 A frame 125 A)	S-T100	38 (AWG 2)		
	MR-J4-DU55KB4/A4	225 A frame 175 A (225 A frame 150 A)	S-N150	38 (AWG 2)		

Drive unit model <sup>(Note 2)</sup>	Wire size [mm <sup>2</sup> ] <sup>(Note 4, 5)</sup>	
	U, V, W, E	L11, L21
MR-J4-DU900B	14 (AWG 6)	1.25 to 2 (AWG 16 to 14)
MR-J4-DU11KB	14 (AWG 6)	
MR-J4-DU15KB	22 (AWG 4)	
MR-J4-DU22KB	38 (AWG 2)	
MR-J4-DU30KB/A	60 (AWG 2/0)	
MR-J4-DU37KB/A	60 (AWG 2/0)	
MR-J4-DU900B4	8 (AWG 8)	
MR-J4-DU11KB4	8 (AWG 8)	
MR-J4-DU15KB4	8 (AWG 8)	
MR-J4-DU22KB4	14 (AWG 6)	
MR-J4-DU30KB4/A4	22 (AWG 4)	
MR-J4-DU37KB4/A4	22 (AWG 4)	
MR-J4-DU45KB4/A4	38 (AWG 2)	
MR-J4-DU55KB4/A4	38 (AWG 2)	

- Notes: 1. Be sure to use a magnetic contactor with an operation delay time of 80 ms or less. The operation delay time is the time interval from current being applied to the coil until closure of contacts.
2. When connecting the wires to the terminal blocks, be sure to use the screws attached to the terminal blocks.
3. Install one molded-case circuit breaker and one magnetic contactor for each resistance regeneration converter unit.
4. When complying with IEC/EN/UL/CSA standard, refer to "MR-CV\_ MR-CR55K\_ MR-J4-DU\_B\_(-RJ) MR-J4-DU\_A\_(-RJ) Instruction Manual". When using a power improving reactor, use a molded-case circuit breaker listed in the brackets.
5. Wires are selected based on the highest rated current among the servo motors to be combined.

**Wires (Example of Selection for MR-J4W2-B and MR-J4W3-B)**

WB

The following are examples of wire sizes when 600 V grade heat-resistant polyvinyl chloride insulated wires (HIV wires) are used. The wire size for U, V, W, and E varies depending on the servo motor. Refer to "Selection Example in HIV Wires for Servo Motors" in this catalog for details on wires for each servo motor.

Servo amplifier model	Molded-case circuit breaker	Magnetic contactor	Wire size [mm <sup>2</sup> ] (Note 3)			
			L1, L2, L3, ⊕	L11, L21	P+, C (Note 5)	U, V, W, E
MR-J4W2-22B	Refer to the following tables.	Refer to the following tables.	2 (AWG 14)			AWG 18 to 14 (Note 2)
MR-J4W2-44B						
MR-J4W2-77B						
MR-J4W2-1010B						
MR-J4W3-222B						
MR-J4W3-444B						

**Molded-Case Circuit Breakers and Magnetic Contactors (Example of Selection for MR-J4W2-B)** (Note 4)

WB

Total output of rotary servo motors	Total continuous thrust of linear servo motors	Total output of direct drive motors	Molded-case circuit breaker (Note 3, 6)	Magnetic contactor (Note 1, 6)
300 W or less	-	-	30 A frame 5 A	S-T10
Over 300 W to 600 W	150 N or less	100 W or less	30 A frame 10 A	S-T10
Over 600 W to 1 kW	Over 150 N to 300 N	Over 100 W to 252 W	30 A frame 15 A	S-T10
Over 1 kW to 2 kW	Over 300 N to 720 N	Over 252 W to 838 W	30 A frame 20 A	S-T21

**Molded-Case Circuit Breakers and Magnetic Contactors (Example of Selection for MR-J4W3-B)** (Note 4)

WB

Total output of rotary servo motors	Total continuous thrust of linear servo motors	Total output of direct drive motors	Molded-case circuit breaker (Note 3, 6)	Magnetic contactor (Note 1, 6)
450 W or less	150 N or less	-	30 A frame 10 A	S-T10
Over 450 W to 800 W	Over 150 N to 300 N	252 W or less	30 A frame 15 A	S-T10
Over 800 W to 1.5 kW	Over 300 N to 450 N	Over 252 W to 378 W	30 A frame 20 A	S-T21

- Notes: 1. Be sure to use a magnetic contactor with an operation delay time of 80 ms or less. The operation delay time is the time interval from current being applied to the coil until closure of contacts.  
 2. The wire size shows applicable size for the servo amplifier connector.  
 3. When complying with IEC/EN/UL/CSA standard, refer to "MR-J4W2-\_B MR-J4W3-\_B MR-J4W2-0303B6 Servo Amplifier Instruction Manual".  
 4. When different types of servo motors (rotary servo motor, linear servo motor, or direct drive motor) are connected to the multi-axis servo amplifier, refer to "MR-J4W2-\_B MR-J4W3-\_B MR-J4W2-0303B6 Servo Amplifier Instruction Manual" for selecting a molded-case circuit breaker and a magnetic contactor.  
 5. Keep the wire length to the regenerative option within 5 m.  
 6. Install one molded-case circuit breaker and one magnetic contactor for each servo amplifier.

**Wires (Example of Selection for MR-J4W2-0303B6/MR-J4-03A6)**

WB A A-RJ

The following are examples of wire sizes when 600 V grade heat-resistant polyvinyl chloride insulated wires (HIV wires) with a length of 30 m are used.

Servo amplifier model	Wire size	
	24, 0, PM, ⊕	U, V, W, E
MR-J4W2-0303B6	AWG 16 (Note 1)	AWG 19
MR-J4-03A6		

Notes: 1. A voltage drop occurs by the current supplied to the servo amplifier according to the wiring impedance.

**Circuit Protector** (Note 1)

WB A A-RJ

Power supply specifications	MR-J4W2-0303B6	MR-J4-03A6
Control circuit power supply (24 V DC)	CP30-BA 1P 1-M 1A	CP30-BA 1P 1-M 1A
Main circuit power supply (48 V DC)	CP30-BA 1P 1-M 5A	CP30-BA 1P 1-M 3A
Main circuit power supply (24 V DC)	CP30-BA 1P 1-M 10A	CP30-BA 1P 1-M 5A

Notes: 1. Use the circuit protector whose operation characteristic is medium-speed type.

Servo Amplifiers  
 Rotary Servo Motors  
 Linear Servo Motors  
 Direct Drive Motors  
 Options/Peripheral Equipment  
 LVS/Wires  
 Product List  
 Precautions

# Low-Voltage Switchgear/Wires

## Type E Combination Motor Controller

**GF** **GF-RJ** **B** **B-RJ** **WB** **A** **A-RJ**

The Type E Combination Motor Controller is comprised of the Manual Motor Starter, Short-circuit Display Unit "UT-TU", and Power Side Terminal Cover Kit "UT-CV3". (Note 3)

Servo amplifier model	Rated input voltage AC [V]	Input phase (Note 2)	Manual Motor Starter			SCCR [kA] (Note 1)
			Model (Mitsubishi Electric)	Rated voltage AC [V]	Rated current [A] (Heater design)	
MR-J4-10GF/B/A	200 to 240	3-phase	MMP-T32	240	1.6	50
MR-J4-20GF/B/A					2.5	
MR-J4-40GF/B/A					4	
MR-J4-60GF/B/A					6.3	
MR-J4-70GF/B/A					6.3	
MR-J4-100GF/B/A					8	
MR-J4-200GF/B/A					18	
MR-J4-350GF/B/A					25	
MR-J4-500GF/B/A					32	
MR-J4-60GF4/B4/A4					380 to 480	
MR-J4-100GF4/B4/A4	4					
MR-J4-200GF4/B4/A4	8					
MR-J4-350GF4/B4/A4	13					
MR-J4-500GF4/B4/A4	18					
MR-J4-700GF4/B4/A4	25					
MR-J4W2-22B	200 to 240	3-phase	MMP-T32	240	6.3	50
MR-J4W2-44B					8	
MR-J4W2-77B					13	
MR-J4W2-1010B					18	
MR-J4W3-222B					8	
MR-J4W3-444B					13	

- Notes: 1. The value is applicable when the Type E Combination Motor Controller is combined with the servo amplifier.  
 2. 1-phase power input is not supported.  
 3. Information on the UL standard on p. 6-4 is for MMP-T series products that bear the UL mark only.



**Selection Example in HIV Wires for Servo Motors** GF GF-RJ B B-RJ B-RJ100 WB A A-RJ

The following are examples of wire sizes when 600 V grade heat-resistant polyvinyl chloride insulated wires (HIV wires) with a length of 30 m are used. Refer to "Servo Motor Instruction Manual (Vol. 3)" when using cab-tire cables for supplying power (U, V, and W) to HG-SR/HG-JR/HG-RR/HG-UR series.

Rotary servo motor model	Wire size [mm <sup>2</sup> ]		
	For power and grounding (U, V, W, E)	For electromagnetic brake (B1, B2)	For cooling fan (BU, BV, BW)
HG-KR053, 13, 23, 43, 73	0.75 (AWG 18) <sup>(Note 1, 2, 3)</sup>	0.5 (AWG 20) <sup>(Note 4, 7)</sup>	
HG-MR053, 13, 23, 43, 73			
HG-SR51, 81	1.25 (AWG 16) <sup>(Note 5)</sup>	1.25 (AWG 16)	
HG-SR121, 201	2 (AWG 14)		
HG-SR301	3.5 (AWG 12)		
HG-SR421	5.5 (AWG 10)		
HG-SR52, 102	1.25 (AWG 16) <sup>(Note 5)</sup>		
HG-SR152, 202	2 (AWG 14)		
HG-SR352	3.5 (AWG 12)		
HG-SR502	5.5 (AWG 10)		
HG-SR702	8 (AWG 8) <sup>(Note 6)</sup>		
HG-SR524, 1024	1.25 (AWG 16) <sup>(Note 5)</sup>		
HG-SR1524, 2024, 3524	2 (AWG 14)		
HG-SR5024	3.5 (AWG 12)		
HG-SR7024	5.5 (AWG 10) <sup>(Note 6)</sup>		
HG-JR53, 73, 103	1.25 (AWG 16) <sup>(Note 5, 6)</sup>		
HG-JR153, 203	2 (AWG 14) <sup>(Note 6)</sup>		
HG-JR353	3.5 (AWG 12) <sup>(Note 6)</sup>		
HG-JR503	5.5 (AWG 10) <sup>(Note 6)</sup>		
HG-JR703 <sup>(Note 6)</sup> , 601, 701M <sup>(Note 6)</sup>	8 (AWG 8)		
HG-JR903, 801, 12K1, 11K1M	14 (AWG 6)		
HG-JR15K1	22 (AWG 4)	1.25 (AWG 16)	
HG-JR15K1M	22 (AWG 4)	-	
HG-JR20K1, 25K1, 22K1M	38 (AWG 2)	-	1.25 (AWG 16)
HG-JR30K1, 37K1, 30K1M, 37K1M	60 (AWG 2/0)	-	1.25 (AWG 16)
HG-JR534, 734, 1034	1.25 (AWG 16) <sup>(Note 5, 6)</sup>	1.25 (AWG 16)	
HG-JR1534, 2034, 3534	2 (AWG 14) <sup>(Note 6)</sup>		
HG-JR5034	3.5 (AWG 12) <sup>(Note 6)</sup>		
HG-JR7034 <sup>(Note 6)</sup> , 6014, 701M4 <sup>(Note 6)</sup> , 8014	5.5 (AWG 10)		
HG-JR9034, 12K14, 11K1M4, 15K1M4	8 (AWG 8)		
HG-JR15K14	8 (AWG 8)	-	1.25 (AWG 16)
HG-JR20K14, 25K14, 30K14, 22K1M4	14 (AWG 6)	-	1.25 (AWG 16)
HG-JR37K14, 30K1M4, 37K1M4	22 (AWG 4)	-	1.25 (AWG 16)
HG-JR45K1M4, 55K1M4	38 (AWG 2)	-	1.25 (AWG 16)
HG-RR103, 153	2 (AWG 14)	1.25 (AWG 16)	
HG-RR203	3.5 (AWG 12)		
HG-RR353, 503	5.5 (AWG 10)		
HG-UR72	1.25 (AWG 16) <sup>(Note 5)</sup>		
HG-UR152	2 (AWG 14)		
HG-UR202	3.5 (AWG 12)		
HG-UR352, 502	5.5 (AWG 10)		

Rotary servo motor model	Wire size [mm <sup>2</sup> ] <sup>(Note 3)</sup>	
	For power and grounding (U, V, W, E)	For cooling fan (BU, BV, E)
HG-JR110K24W0C HG-JR150K24W0C HG-JR180K24W0C HG-JR200K24W0C HG-JR220K24W0C	38 (AWG 2) <sup>(Note 8)</sup>	0.75 (AWG 18)

- Notes: 1. Use a fluorine resin wire of 0.75 mm<sup>2</sup> (AWG 18) for wiring to the servo motor power supply.  
 2. This size is applicable for wiring length of 10 m or shorter. For over 10 m, use MR-PWS2CBL03M-A\_-L and extend it with HIV wire of 1.25 mm<sup>2</sup> (AWG 16).  
 3. Use a cable provided by Mitsubishi Electric or Mitsubishi Electric System & Service Co., Ltd. When fabricating a cable, select wires applicable for the usage. The National Electrical Code recommends that the wire size should be a minimum of AWG 14 (2 mm<sup>2</sup>).  
 4. Use a fluorine resin wire of 0.5 mm<sup>2</sup> (AWG 20) for wiring to servo motor electromagnetic brake.  
 5. The National Electrical Code recommends that the wire size should be a minimum of AWG 14 (2 mm<sup>2</sup>). Refer to "Servo Motor Instruction Manual (Vol. 3)" for details.  
 6. The same wire size is applicable when the maximum torque is increased.  
 7. This size is applicable for wiring length of 10 m or shorter. For over 10 m, extend the wire with HIV wire of 1.25 mm<sup>2</sup> (AWG 16).  
 8. Use non-halogen, flame-retardant, flexible, cross-linked polyethylene insulated electric wires (EM-LMFC) for U, V, W.

Servo Amplifiers  
Rotary Servo Motors  
Linear Servo Motors  
Direct Drive Motors  
Options/Peripheral Equipment  
LV/S/Wires  
Product List  
Precautions

# Low-Voltage Switchgear/Wires

## Selection Example in HIV Wires for Servo Motors

GF GF-RJ B B-RJ WB A A-RJ

The following are examples of wire sizes when 600 V grade heat-resistant polyvinyl chloride insulated wires (HIV wires) with a length of 30 m are used.

Rotary servo motor model	Wire size [mm <sup>2</sup> ]	
	For power and grounding (U, V, W, E)	B1, B2
HG-AK series	0.75 (AWG 18) <sup>(Note 1, 2, 5)</sup>	0.75 (AWG 18) <sup>(Note 3, 4)</sup>

- Notes: 1. Use a fluorine resin wire of 0.75 mm<sup>2</sup> (AWG 18) for wiring to the servo motor power supply.  
 2. This size is applicable for wiring length of 5 m or shorter. When an option cable longer than 5 m is used, the torque characteristics in the short-duration running range may be lower because of voltage drop.  
 3. Use a fluorine resin wire of 0.75 mm<sup>2</sup> (AWG 18) for wiring to servo motor electromagnetic brake.  
 4. This size is applicable for wiring length of 5 m or shorter. For over 5 m, extend the wire with HIV wire of 3.5 mm<sup>2</sup> (AWG 12).  
 5. Use a cable provided by Mitsubishi Electric or Mitsubishi Electric System & Service Co., Ltd. When fabricating a cable, select wires applicable for the usage. The National Electrical Code recommends that the wire size should be a minimum of AWG 14 (2 mm<sup>2</sup>).

Linear servo motor model Primary side	Wire size [mm <sup>2</sup> ]		
	For power and grounding (U, V, W, E)	For thermistor (G1, G2)	
LM-H3P2A-07P-BSS0	1.25 (AWG 16) <sup>(Note 1)</sup>	0.2 (AWG 24)	
LM-H3P3A-12P-CSS0	1.25 (AWG 16) <sup>(Note 1)</sup>		
LM-H3P3B-24P-CSS0	1.25 (AWG 16) <sup>(Note 1)</sup>		
LM-H3P3C-36P-CSS0	1.25 (AWG 16) <sup>(Note 1)</sup>		
LM-H3P3D-48P-CSS0	2 (AWG 14)		
LM-H3P7A-24P-ASS0	1.25 (AWG 16) <sup>(Note 1)</sup>		
LM-H3P7B-48P-ASS0	2 (AWG 14)		
LM-H3P7C-72P-ASS0	2 (AWG 14)		
LM-H3P7D-96P-ASS0	3.5 (AWG 12)		
LM-FP2B-06M-1SS0	Natural cooling		2 (AWG 14)
	Liquid cooling		
LM-FP2D-12M-1SS0	Natural cooling		3.5 (AWG 12)
	Liquid cooling		
LM-FP2F-18M-1SS0	Natural cooling		3.5 (AWG 12) <sup>(Note 2)</sup>
	Liquid cooling		
LM-FP4B-12M-1SS0	Natural cooling		5.5 (AWG 10)
	Liquid cooling		
LM-FP4D-24M-1SS0	Natural cooling		5.5 (AWG 10)
	Liquid cooling		
LM-FP4F-36M-1SS0	Natural cooling		8 (AWG 8) <sup>(Note 2)</sup>
	Liquid cooling		
LM-FP4H-48M-1SS0	Natural cooling		8 (AWG 8) <sup>(Note 3)</sup>
	Liquid cooling		
LM-FP5H-60M-1SS0	Natural cooling		8 (AWG 8)
	Liquid cooling		
LM-K2P1A-01M-2SS1	1.25 (AWG 16) <sup>(Note 1)</sup>		
LM-K2P1C-03M-2SS1	2 (AWG 14)		
LM-K2P2A-02M-1SS1	1.25 (AWG 16) <sup>(Note 1)</sup>		
LM-K2P2C-07M-1SS1	3.5 (AWG 12)		
LM-K2P2E-12M-1SS1	5.5 (AWG 10)		
LM-K2P3C-14M-1SS1	3.5 (AWG 12)		
LM-K2P3E-24M-1SS1	5.5 (AWG 10)		
LM-U2PAB-05M-0SS0, LM-U2PAD-10M-0SS0, LM-U2PAF-15M-0SS0, LM-U2PBB-07M-1SS0, LM-U2PBD-15M-1SS0, LM-U2PBF-22M-1SS0	1.25 (AWG 16) <sup>(Note 1)</sup>		
LM-U2P2B-40M-2SS0	2 (AWG 14)		
LM-U2P2C-60M-2SS0	3.5 (AWG 12)		
LM-U2P2D-80M-2SS0	5.5 (AWG 10)		

Direct drive motor model	Wire size [mm <sup>2</sup> ]
	For power and grounding (U, V, W, E)
TM-RG2M002C30, TM-RG2M004E30, TM-RG2M009G30, TM-RU2M002C30, TM-RU2M004E30, TM-RU2M009G30	0.75 (AWG 18) <sup>(Note 1, 4)</sup>
TM-RFM002C20, TM-RFM004C20, TM-RFM006C20, TM-RFM006E20, TM-RFM012E20, TM-RFM018E20, TM-RFM012G20	1.25 (AWG 16) <sup>(Note 1)</sup>
TM-RFM048G20, TM-RFM072G20	3.5 (AWG 12)
TM-RFM040J10	1.25 (AWG 16) <sup>(Note 1)</sup>
TM-RFM120J10	3.5 (AWG 12)
TM-RFM240J10	5.5 (AWG 10)

- Notes: 1. The National Electrical Code recommends that the wire size should be a minimum of AWG 14 (2 mm<sup>2</sup>). Refer to relevant Servo Motor Instruction Manual for details.  
 2. Use a wire which has a heat resistance temperature of 105 °C for wiring to the servo motor power supply.  
 3. Use a wire which has a heat resistance temperature of 150 °C for wiring to the servo motor power supply.  
 4. The same wire size is applicable when the rated torque and the maximum torque are increased.

MEMO

Servo Amplifiers

Rotary Servo Motors

Linear Servo Motors

Direct Drive Motors

Options/Peripheral  
Equipment

**LVS/Wires**

Product List

Precautions

# Product List

## Servo amplifiers

Item	Model	Rated output	Main circuit power supply	
Servo amplifier MR-J4-GF	200 V class	MR-J4-10GF	0.1 kW	3-phase or 1-phase 200 V AC to 240 V AC
		MR-J4-20GF	0.2 kW	3-phase or 1-phase 200 V AC to 240 V AC
		MR-J4-40GF	0.4 kW	3-phase or 1-phase 200 V AC to 240 V AC
		MR-J4-60GF	0.6 kW	3-phase or 1-phase 200 V AC to 240 V AC
		MR-J4-70GF	0.75 kW	3-phase or 1-phase 200 V AC to 240 V AC
		MR-J4-100GF	1 kW	3-phase or 1-phase 200 V AC to 240 V AC
		MR-J4-200GF	2 kW	3-phase or 1-phase 200 V AC to 240 V AC
		MR-J4-350GF	3.5 kW	3-phase 200 V AC to 240 V AC
		MR-J4-500GF	5 kW	3-phase 200 V AC to 240 V AC
		MR-J4-700GF	7 kW	3-phase 200 V AC to 240 V AC
		MR-J4-11KGF	11 kW	3-phase 200 V AC to 240 V AC
		MR-J4-15KGF	15 kW	3-phase 200 V AC to 240 V AC
	MR-J4-22KGF	22 kW	3-phase 200 V AC to 240 V AC	
	100 V class	MR-J4-10GF1	0.1 kW	1-phase 100 V AC to 120 V AC
		MR-J4-20GF1	0.2 kW	1-phase 100 V AC to 120 V AC
		MR-J4-40GF1	0.4 kW	1-phase 100 V AC to 120 V AC
	400 V class	MR-J4-60GF4	0.6 kW	3-phase 380 V AC to 480 V AC
		MR-J4-100GF4	1 kW	3-phase 380 V AC to 480 V AC
		MR-J4-200GF4	2 kW	3-phase 380 V AC to 480 V AC
		MR-J4-350GF4	3.5 kW	3-phase 380 V AC to 480 V AC
		MR-J4-500GF4	5 kW	3-phase 380 V AC to 480 V AC
		MR-J4-700GF4	7 kW	3-phase 380 V AC to 480 V AC
		MR-J4-11KGF4	11 kW	3-phase 380 V AC to 480 V AC
		MR-J4-15KGF4	15 kW	3-phase 380 V AC to 480 V AC
MR-J4-22KGF4	22 kW	3-phase 380 V AC to 480 V AC		
Servo amplifier MR-J4-GF-RJ	200 V class	MR-J4-10GF-RJ	0.1 kW	3-phase or 1-phase 200 V AC to 240 V AC, 283 V DC to 340 V DC
		MR-J4-20GF-RJ	0.2 kW	3-phase or 1-phase 200 V AC to 240 V AC, 283 V DC to 340 V DC
		MR-J4-40GF-RJ	0.4 kW	3-phase or 1-phase 200 V AC to 240 V AC, 283 V DC to 340 V DC
		MR-J4-60GF-RJ	0.6 kW	3-phase or 1-phase 200 V AC to 240 V AC, 283 V DC to 340 V DC
		MR-J4-70GF-RJ	0.75 kW	3-phase or 1-phase 200 V AC to 240 V AC, 283 V DC to 340 V DC
		MR-J4-100GF-RJ	1 kW	3-phase or 1-phase 200 V AC to 240 V AC, 283 V DC to 340 V DC
		MR-J4-200GF-RJ	2 kW	3-phase or 1-phase 200 V AC to 240 V AC, 283 V DC to 340 V DC
		MR-J4-350GF-RJ	3.5 kW	3-phase 200 V AC to 240 V AC, 283 V DC to 340 V DC
		MR-J4-500GF-RJ	5 kW	3-phase 200 V AC to 240 V AC, 283 V DC to 340 V DC
		MR-J4-700GF-RJ	7 kW	3-phase 200 V AC to 240 V AC, 283 V DC to 340 V DC
		MR-J4-11KGF-RJ	11 kW	3-phase 200 V AC to 240 V AC, 283 V DC to 340 V DC
		MR-J4-15KGF-RJ	15 kW	3-phase 200 V AC to 240 V AC, 283 V DC to 340 V DC
	MR-J4-22KGF-RJ	22 kW	3-phase 200 V AC to 240 V AC, 283 V DC to 340 V DC	
	100 V class	MR-J4-10GF1-RJ	0.1 kW	1-phase 100 V AC to 120 V AC
		MR-J4-20GF1-RJ	0.2 kW	1-phase 100 V AC to 120 V AC
		MR-J4-40GF1-RJ	0.4 kW	1-phase 100 V AC to 120 V AC

Servo amplifiers

Item	Model	Rated output	Main circuit power supply	
Servo amplifier MR-J4-G-RJ	400 V class	MR-J4-60GF4-RJ	0.6 kW	3-phase 380 V AC to 480 V AC
		MR-J4-100GF4-RJ	1 kW	3-phase 380 V AC to 480 V AC
		MR-J4-200GF4-RJ	2 kW	3-phase 380 V AC to 480 V AC
		MR-J4-350GF4-RJ	3.5 kW	3-phase 380 V AC to 480 V AC
		MR-J4-500GF4-RJ	5 kW	3-phase 380 V AC to 480 V AC
		MR-J4-700GF4-RJ	7 kW	3-phase 380 V AC to 480 V AC
		MR-J4-11KGF4-RJ	11 kW	3-phase 380 V AC to 480 V AC
		MR-J4-15KGF4-RJ	15 kW	3-phase 380 V AC to 480 V AC
Servo amplifier MR-J4-B	200 V class	MR-J4-10B	0.1 kW	3-phase or 1-phase 200 V AC to 240 V AC
		MR-J4-20B	0.2 kW	3-phase or 1-phase 200 V AC to 240 V AC
		MR-J4-40B	0.4 kW	3-phase or 1-phase 200 V AC to 240 V AC
		MR-J4-60B	0.6 kW	3-phase or 1-phase 200 V AC to 240 V AC
		MR-J4-70B	0.75 kW	3-phase or 1-phase 200 V AC to 240 V AC
		MR-J4-100B	1 kW	3-phase or 1-phase 200 V AC to 240 V AC
		MR-J4-200B	2 kW	3-phase or 1-phase 200 V AC to 240 V AC
		MR-J4-350B	3.5 kW	3-phase 200 V AC to 240 V AC
		MR-J4-500B	5 kW	3-phase 200 V AC to 240 V AC
		MR-J4-700B	7 kW	3-phase 200 V AC to 240 V AC
		MR-J4-11KB	11 kW	3-phase 200 V AC to 240 V AC
		MR-J4-15KB	15 kW	3-phase 200 V AC to 240 V AC
		MR-J4-22KB	22 kW	3-phase 200 V AC to 240 V AC
		100 V class	MR-J4-10B1	0.1 kW
	MR-J4-20B1		0.2 kW	1-phase 100 V AC to 120 V AC
	400 V class	MR-J4-40B1	0.4 kW	1-phase 100 V AC to 120 V AC
		MR-J4-60B4	0.6 kW	3-phase 380 V AC to 480 V AC
		MR-J4-100B4	1 kW	3-phase 380 V AC to 480 V AC
		MR-J4-200B4	2 kW	3-phase 380 V AC to 480 V AC
		MR-J4-350B4	3.5 kW	3-phase 380 V AC to 480 V AC
		MR-J4-500B4	5 kW	3-phase 380 V AC to 480 V AC
		MR-J4-700B4	7 kW	3-phase 380 V AC to 480 V AC
MR-J4-11KB4		11 kW	3-phase 380 V AC to 480 V AC	
Drive unit MR-J4-DUB	200 V class	MR-J4-DU900B	9 kW	Main circuit power is supplied from the power regeneration converter unit to the drive unit.
		MR-J4-DU11KB	11 kW	
		MR-J4-DU15KB	15 kW	
		MR-J4-DU22KB	22 kW	
		MR-J4-DU30KB <sup>(Note 1)</sup>	30 kW	Main circuit power is supplied from the power regeneration converter unit or the resistance regeneration converter unit to the drive unit.
		MR-J4-DU37KB <sup>(Note 1)</sup>	37 kW	
	400 V class	MR-J4-DU900B4	9 kW	Main circuit power is supplied from the power regeneration converter unit to the drive unit.
		MR-J4-DU11KB4	11 kW	
		MR-J4-DU15KB4	15 kW	
		MR-J4-DU22KB4	22 kW	
		MR-J4-DU30KB4 <sup>(Note 1)</sup>	30 kW	Main circuit power is supplied from the power regeneration converter unit or the resistance regeneration converter unit to the drive unit.
		MR-J4-DU37KB4 <sup>(Note 1)</sup>	37 kW	
		MR-J4-DU45KB4 <sup>(Note 1)</sup>	45 kW	
		MR-J4-DU55KB4 <sup>(Note 1)</sup>	55 kW	

Notes:

- When the drive unit is combined with a resistance regeneration converter unit, one unit of the resistance regeneration converter unit is required for each drive unit.

Servo Amplifiers

Rotary Servo Motors

Linear Servo Motors

Direct Drive Motors

Options/Peripheral Equipment

LVS/Wires

Product List

Precautions

# Product List

## Servo amplifiers

Item	Model	Rated output	Main circuit power supply	
Servo amplifier MR-J4-B-RJ	MR-J4-10B-RJ	0.1 kW	3-phase or 1-phase 200 V AC to 240 V AC, 283 V DC to 340 V DC	
	MR-J4-20B-RJ	0.2 kW	3-phase or 1-phase 200 V AC to 240 V AC, 283 V DC to 340 V DC	
	MR-J4-40B-RJ	0.4 kW	3-phase or 1-phase 200 V AC to 240 V AC, 283 V DC to 340 V DC	
	MR-J4-60B-RJ	0.6 kW	3-phase or 1-phase 200 V AC to 240 V AC, 283 V DC to 340 V DC	
	MR-J4-70B-RJ	0.75 kW	3-phase or 1-phase 200 V AC to 240 V AC, 283 V DC to 340 V DC	
	MR-J4-100B-RJ	1 kW	3-phase or 1-phase 200 V AC to 240 V AC, 283 V DC to 340 V DC	
	MR-J4-200B-RJ	2 kW	3-phase or 1-phase 200 V AC to 240 V AC, 283 V DC to 340 V DC	
	MR-J4-350B-RJ	3.5 kW	3-phase 200 V AC to 240 V AC, 283 V DC to 340 V DC	
	MR-J4-500B-RJ	5 kW	3-phase 200 V AC to 240 V AC, 283 V DC to 340 V DC	
	MR-J4-700B-RJ	7 kW	3-phase 200 V AC to 240 V AC, 283 V DC to 340 V DC	
	MR-J4-11KB-RJ	11 kW	3-phase 200 V AC to 240 V AC, 283 V DC to 340 V DC	
	MR-J4-15KB-RJ	15 kW	3-phase 200 V AC to 240 V AC, 283 V DC to 340 V DC	
	MR-J4-22KB-RJ	22 kW	3-phase 200 V AC to 240 V AC, 283 V DC to 340 V DC	
	100 V class	MR-J4-10B1-RJ	0.1 kW	1-phase 100 V AC to 120 V AC
		MR-J4-20B1-RJ	0.2 kW	1-phase 100 V AC to 120 V AC
		MR-J4-40B1-RJ	0.4 kW	1-phase 100 V AC to 120 V AC
	400 V class	MR-J4-60B4-RJ	0.6 kW	3-phase 380 V AC to 480 V AC
		MR-J4-100B4-RJ	1 kW	3-phase 380 V AC to 480 V AC
		MR-J4-200B4-RJ	2 kW	3-phase 380 V AC to 480 V AC
		MR-J4-350B4-RJ	3.5 kW	3-phase 380 V AC to 480 V AC
		MR-J4-500B4-RJ	5 kW	3-phase 380 V AC to 480 V AC
		MR-J4-700B4-RJ	7 kW	3-phase 380 V AC to 480 V AC
MR-J4-11KB4-RJ		11 kW	3-phase 380 V AC to 480 V AC	
MR-J4-15KB4-RJ		15 kW	3-phase 380 V AC to 480 V AC	
MR-J4-22KB4-RJ	22 kW	3-phase 380 V AC to 480 V AC		
Drive unit MR-J4-DUB-RJ	MR-J4-DU900B-RJ	9 kW	Main circuit power is supplied from the power regeneration converter unit to the drive unit.	
	MR-J4-DU11KB-RJ	11 kW		
	MR-J4-DU15KB-RJ	15 kW		
	MR-J4-DU22KB-RJ	22 kW		
	MR-J4-DU30KB-RJ <sup>(Note 1)</sup>	30 kW		
	MR-J4-DU37KB-RJ <sup>(Note 1)</sup>	37 kW	Main circuit power is supplied from the power regeneration converter unit or the resistance regeneration converter unit to the drive unit.	
	MR-J4-DU900B4-RJ	9 kW		
	MR-J4-DU11KB4-RJ	11 kW	Main circuit power is supplied from the power regeneration converter unit to the drive unit.	
	MR-J4-DU15KB4-RJ	15 kW		
	MR-J4-DU22KB4-RJ	22 kW		
	MR-J4-DU30KB4-RJ <sup>(Note 1)</sup>	30 kW	Main circuit power is supplied from the power regeneration converter unit or the resistance regeneration converter unit to the drive unit.	
	MR-J4-DU37KB4-RJ <sup>(Note 1)</sup>	37 kW		
	MR-J4-DU45KB4-RJ <sup>(Note 1)</sup>	45 kW		
MR-J4-DU55KB4-RJ <sup>(Note 1)</sup>	55 kW			
MR-J4-DU55KB4-RJ100	55 kW			
Drive unit MR-J4-DUB-RJ100	400 V class	MR-J4-DU45KB4-RJ100	45 kW	Main circuit power is supplied from the power regeneration converter unit to the drive unit.
		MR-J4-DU55KB4-RJ100	55 kW	

Notes:  
1. When the drive unit is combined with a resistance regeneration converter unit, one unit of the resistance regeneration converter unit is required for each drive unit.

Servo amplifiers

Item		Model	Rated output	Main circuit power supply
Servo amplifier MR-J4W2-B	200 V class	MR-J4W2-22B	0.2 kW × 2 axes	3-phase or 1-phase 200 V AC to 240 V AC
		MR-J4W2-44B	0.4 kW × 2 axes	3-phase or 1-phase 200 V AC to 240 V AC
		MR-J4W2-77B	0.75 kW × 2 axes	3-phase or 1-phase 200 V AC to 240 V AC
		MR-J4W2-1010B	1 kW × 2 axes	3-phase 200 V AC to 240 V AC
	48 V DC/ 24 V DC	MR-J4W2-0303B6	30 W × 2 axes	48 V DC/24 V DC
Servo amplifier MR-J4W3-B	200 V class	MR-J4W3-222B	0.2 kW × 3 axes	3-phase or 1-phase 200 V AC to 240 V AC
		MR-J4W3-444B	0.4 kW × 3 axes	3-phase or 1-phase 200 V AC to 240 V AC
Servo amplifier MR-J4-A	200 V class	MR-J4-10A	0.1 kW	3-phase or 1-phase 200 V AC to 240 V AC
		MR-J4-20A	0.2 kW	3-phase or 1-phase 200 V AC to 240 V AC
		MR-J4-40A	0.4 kW	3-phase or 1-phase 200 V AC to 240 V AC
		MR-J4-60A	0.6 kW	3-phase or 1-phase 200 V AC to 240 V AC
		MR-J4-70A	0.75 kW	3-phase or 1-phase 200 V AC to 240 V AC
		MR-J4-100A	1 kW	3-phase or 1-phase 200 V AC to 240 V AC
		MR-J4-200A	2 kW	3-phase or 1-phase 200 V AC to 240 V AC
		MR-J4-350A	3.5 kW	3-phase 200 V AC to 240 V AC
		MR-J4-500A	5 kW	3-phase 200 V AC to 240 V AC
		MR-J4-700A	7 kW	3-phase 200 V AC to 240 V AC
		MR-J4-11KA	11 kW	3-phase 200 V AC to 240 V AC
		MR-J4-15KA	15 kW	3-phase 200 V AC to 240 V AC
		MR-J4-22KA	22 kW	3-phase 200 V AC to 240 V AC
		100 V class	MR-J4-10A1	0.1 kW
	MR-J4-20A1		0.2 kW	1-phase 100 V AC to 120 V AC
	MR-J4-40A1		0.4 kW	1-phase 100 V AC to 120 V AC
	400 V class	MR-J4-60A4	0.6 kW	3-phase 380 V AC to 480 V AC
		MR-J4-100A4	1 kW	3-phase 380 V AC to 480 V AC
		MR-J4-200A4	2 kW	3-phase 380 V AC to 480 V AC
		MR-J4-350A4	3.5 kW	3-phase 380 V AC to 480 V AC
		MR-J4-500A4	5 kW	3-phase 380 V AC to 480 V AC
		MR-J4-700A4	7 kW	3-phase 380 V AC to 480 V AC
		MR-J4-11KA4	11 kW	3-phase 380 V AC to 480 V AC
		MR-J4-15KA4	15 kW	3-phase 380 V AC to 480 V AC
	48 V DC/ 24 V DC	MR-J4-03A6	30 W	48 V DC/24 V DC
	Drive unit MR-J4-DUA <sup>(Note 1)</sup>	200 V class	MR-J4-DU30KA	30 kW
MR-J4-DU37KA			37 kW	
400 V class		MR-J4-DU30KA4	30 kW	
		MR-J4-DU37KA4	37 kW	
		MR-J4-DU45KA4	45 kW	
		MR-J4-DU55KA4	55 kW	

Notes:

- When the drive unit is combined with a resistance regeneration converter unit, one unit of the resistance regeneration converter unit is required for each drive unit.

Servo Amplifiers

Rotary Servo Motors

Linear Servo Motors

Direct Drive Motors

Options/Peripheral Equipment

LVS/Wires

Product List

Precautions

# Product List

## Servo amplifiers

Item		Model	Rated output	Main circuit power supply
Servo amplifier MR-J4-A-RJ	200 V class	MR-J4-10A-RJ	0.1 kW	3-phase or 1-phase 200 V AC to 240 V AC, 283 V DC to 340 V DC
		MR-J4-20A-RJ	0.2 kW	3-phase or 1-phase 200 V AC to 240 V AC, 283 V DC to 340 V DC
		MR-J4-40A-RJ	0.4 kW	3-phase or 1-phase 200 V AC to 240 V AC, 283 V DC to 340 V DC
		MR-J4-60A-RJ	0.6 kW	3-phase or 1-phase 200 V AC to 240 V AC, 283 V DC to 340 V DC
		MR-J4-70A-RJ	0.75 kW	3-phase or 1-phase 200 V AC to 240 V AC, 283 V DC to 340 V DC
		MR-J4-100A-RJ	1 kW	3-phase or 1-phase 200 V AC to 240 V AC, 283 V DC to 340 V DC
		MR-J4-200A-RJ	2 kW	3-phase or 1-phase 200 V AC to 240 V AC, 283 V DC to 340 V DC
		MR-J4-350A-RJ	3.5 kW	3-phase 200 V AC to 240 V AC, 283 V DC to 340 V DC
		MR-J4-500A-RJ	5 kW	3-phase 200 V AC to 240 V AC, 283 V DC to 340 V DC
		MR-J4-700A-RJ	7 kW	3-phase 200 V AC to 240 V AC, 283 V DC to 340 V DC
		MR-J4-11KA-RJ	11 kW	3-phase 200 V AC to 240 V AC, 283 V DC to 340 V DC
		MR-J4-15KA-RJ	15 kW	3-phase 200 V AC to 240 V AC, 283 V DC to 340 V DC
		MR-J4-22KA-RJ	22 kW	3-phase 200 V AC to 240 V AC, 283 V DC to 340 V DC
	100 V class	MR-J4-10A1-RJ	0.1 kW	1-phase 100 V AC to 120 V AC
		MR-J4-20A1-RJ	0.2 kW	1-phase 100 V AC to 120 V AC
		MR-J4-40A1-RJ	0.4 kW	1-phase 100 V AC to 120 V AC
	400 V class	MR-J4-60A4-RJ	0.6 kW	3-phase 380 V AC to 480 V AC
		MR-J4-100A4-RJ	1 kW	3-phase 380 V AC to 480 V AC
		MR-J4-200A4-RJ	2 kW	3-phase 380 V AC to 480 V AC
		MR-J4-350A4-RJ	3.5 kW	3-phase 380 V AC to 480 V AC
		MR-J4-500A4-RJ	5 kW	3-phase 380 V AC to 480 V AC
		MR-J4-700A4-RJ	7 kW	3-phase 380 V AC to 480 V AC
		MR-J4-11KA4-RJ	11 kW	3-phase 380 V AC to 480 V AC
		MR-J4-15KA4-RJ	15 kW	3-phase 380 V AC to 480 V AC
	MR-J4-22KA4-RJ	22 kW	3-phase 380 V AC to 480 V AC	
	48 V DC/24 V DC	MR-J4-03A6-RJ	30 W	48 V DC/24 V DC
Drive unit MR-J4-DUA-RJ (Note 1)	200 V class	MR-J4-DU30KA-RJ	30 kW	Main circuit power is supplied from the resistance regeneration converter unit to the drive unit.
		MR-J4-DU37KA-RJ	37 kW	
	400 V class	MR-J4-DU30KA4-RJ	30 kW	
		MR-J4-DU37KA4-RJ	37 kW	
		MR-J4-DU45KA4-RJ	45 kW	
		MR-J4-DU55KA4-RJ	55 kW	

- Notes:
- When the drive unit is combined with a resistance regeneration converter unit, one unit of the resistance regeneration converter unit is required for each drive unit.



Servo amplifiers

Item		Model	Rated output	Main circuit power supply
Power regeneration converter unit MR-CV	200 V class	MR-CV11K	11 kW	3-phase 200 V AC to 240 V AC
		MR-CV18K	18 kW	3-phase 200 V AC to 240 V AC
		MR-CV30K	30 kW	3-phase 200 V AC to 240 V AC
		MR-CV37K	37 kW	3-phase 200 V AC to 240 V AC
		MR-CV45K	45 kW	3-phase 200 V AC to 240 V AC
		MR-CV55K	55 kW	3-phase 200 V AC to 240 V AC
	400 V class	MR-CV11K4	11 kW	3-phase 380 V AC to 480 V AC
		MR-CV18K4	18 kW	3-phase 380 V AC to 480 V AC
		MR-CV30K4	30 kW	3-phase 380 V AC to 480 V AC
		MR-CV37K4	37 kW	3-phase 380 V AC to 480 V AC
		MR-CV45K4	45 kW	3-phase 380 V AC to 480 V AC
		MR-CV55K4	55 kW	3-phase 380 V AC to 480 V AC
Resistance regeneration converter unit MR-CR <sup>(Note 1)</sup>	200 V class	MR-CR55K	55 kW	3-phase 200 V AC to 240 V AC
	400 V class	MR-CR55K4	55 kW	3-phase 380 V AC to 480 V AC

Notes:

1. When the drive unit is combined with a resistance regeneration converter unit, one unit of the resistance regeneration converter unit is required for each drive unit.

Servo Amplifiers

Rotary Servo Motors

Linear Servo Motors

Direct Drive Motors

Options/Peripheral Equipment

LVS/Wires

Product List

Precautions

# Product List

## Rotary servo motors

Item	Model	Rated output	Rated speed	Reduction ratio
HG-KR series B: With electromagnetic brake	HG-KR053(B)	50 W	3000 r/min	-
	HG-KR13(B)	100 W	3000 r/min	-
	HG-KR23(B)	200 W	3000 r/min	-
	HG-KR43(B)	400 W	3000 r/min	-
	HG-KR73(B)	750 W	3000 r/min	-
Servo motors with functional safety HG-KR series B: With electromagnetic brake	HG-KR053(B)W0C	50 W	3000 r/min	-
	HG-KR13(B)W0C	100 W	3000 r/min	-
	HG-KR23(B)W0C	200 W	3000 r/min	-
	HG-KR43(B)W0C	400 W	3000 r/min	-
	HG-KR73(B)W0C	750 W	3000 r/min	-
HG-KR series With gear reducer for general industrial machines B: With electromagnetic brake	HG-KR053(B)G1 1/5	50 W	3000 r/min	1/5
	HG-KR053(B)G1 1/12	50 W	3000 r/min	1/12
	HG-KR053(B)G1 1/20	50 W	3000 r/min	1/20
	HG-KR13(B)G1 1/5	100 W	3000 r/min	1/5
	HG-KR13(B)G1 1/12	100 W	3000 r/min	1/12
	HG-KR13(B)G1 1/20	100 W	3000 r/min	1/20
	HG-KR23(B)G1 1/5	200 W	3000 r/min	1/5
	HG-KR23(B)G1 1/12	200 W	3000 r/min	1/12
	HG-KR23(B)G1 1/20	200 W	3000 r/min	1/20
	HG-KR43(B)G1 1/5	400 W	3000 r/min	1/5
	HG-KR43(B)G1 1/12	400 W	3000 r/min	1/12
	HG-KR43(B)G1 1/20	400 W	3000 r/min	1/20
	HG-KR73(B)G1 1/5	750 W	3000 r/min	1/5
	HG-KR73(B)G1 1/12	750 W	3000 r/min	1/12
	HG-KR73(B)G1 1/20	750 W	3000 r/min	1/20
HG-KR series With flange-output type gear reducer for high precision applications, flange mounting B: With electromagnetic brake	HG-KR053(B)G5 1/5 (40 × 40)	50 W	3000 r/min	1/5 (flange dimensions: 40 mm × 40 mm)
	HG-KR053(B)G5 1/5 (60 × 60)	50 W	3000 r/min	1/5 (flange dimensions: 60 mm × 60 mm)
	HG-KR053(B)G5 1/9	50 W	3000 r/min	1/9
	HG-KR053(B)G5 1/11	50 W	3000 r/min	1/11
	HG-KR053(B)G5 1/21	50 W	3000 r/min	1/21
	HG-KR053(B)G5 1/33	50 W	3000 r/min	1/33
	HG-KR053(B)G5 1/45	50 W	3000 r/min	1/45
	HG-KR13(B)G5 1/5 (40 × 40)	100 W	3000 r/min	1/5 (flange dimensions: 40 mm × 40 mm)
	HG-KR13(B)G5 1/5 (60 × 60)	100 W	3000 r/min	1/5 (flange dimensions: 60 mm × 60 mm)
	HG-KR13(B)G5 1/11	100 W	3000 r/min	1/11
	HG-KR13(B)G5 1/21	100 W	3000 r/min	1/21
	HG-KR13(B)G5 1/33	100 W	3000 r/min	1/33
	HG-KR13(B)G5 1/45	100 W	3000 r/min	1/45
	HG-KR23(B)G5 1/5	200 W	3000 r/min	1/5
	HG-KR23(B)G5 1/11	200 W	3000 r/min	1/11
	HG-KR23(B)G5 1/21	200 W	3000 r/min	1/21
	HG-KR23(B)G5 1/33	200 W	3000 r/min	1/33
	HG-KR23(B)G5 1/45	200 W	3000 r/min	1/45
	HG-KR43(B)G5 1/5	400 W	3000 r/min	1/5
	HG-KR43(B)G5 1/11	400 W	3000 r/min	1/11
	HG-KR43(B)G5 1/21	400 W	3000 r/min	1/21
	HG-KR43(B)G5 1/33	400 W	3000 r/min	1/33
	HG-KR43(B)G5 1/45	400 W	3000 r/min	1/45
	HG-KR73(B)G5 1/5	750 W	3000 r/min	1/5
	HG-KR73(B)G5 1/11	750 W	3000 r/min	1/11
HG-KR73(B)G5 1/21	750 W	3000 r/min	1/21	
HG-KR73(B)G5 1/33	750 W	3000 r/min	1/33	
HG-KR73(B)G5 1/45	750 W	3000 r/min	1/45	

Rotary servo motors

Item	Model	Rated output	Rated speed	Reduction ratio	
HG-KR series With shaft-output type gear reducer for high precision applications, flange mounting  B: With electromagnetic brake	HG-KR053(B)G7 1/5 (40 × 40)	50 W	3000 r/min	1/5 (flange dimensions: 40 mm × 40 mm)	
	HG-KR053(B)G7 1/5 (60 × 60)	50 W	3000 r/min	1/5 (flange dimensions: 60 mm × 60 mm)	
	HG-KR053(B)G7 1/9	50 W	3000 r/min	1/9	
	HG-KR053(B)G7 1/11	50 W	3000 r/min	1/11	
	HG-KR053(B)G7 1/21	50 W	3000 r/min	1/21	
	HG-KR053(B)G7 1/33	50 W	3000 r/min	1/33	
	HG-KR053(B)G7 1/45	50 W	3000 r/min	1/45	
	HG-KR13(B)G7 1/5 (40 × 40)	100 W	3000 r/min	1/5 (flange dimensions: 40 mm × 40 mm)	
	HG-KR13(B)G7 1/5 (60 × 60)	100 W	3000 r/min	1/5 (flange dimensions: 60 mm × 60 mm)	
	HG-KR13(B)G7 1/11	100 W	3000 r/min	1/11	
	HG-KR13(B)G7 1/21	100 W	3000 r/min	1/21	
	HG-KR13(B)G7 1/33	100 W	3000 r/min	1/33	
	HG-KR13(B)G7 1/45	100 W	3000 r/min	1/45	
	HG-KR23(B)G7 1/5	200 W	3000 r/min	1/5	
	HG-KR23(B)G7 1/11	200 W	3000 r/min	1/11	
	HG-KR23(B)G7 1/21	200 W	3000 r/min	1/21	
	HG-KR23(B)G7 1/33	200 W	3000 r/min	1/33	
	HG-KR23(B)G7 1/45	200 W	3000 r/min	1/45	
	HG-KR43(B)G7 1/5	400 W	3000 r/min	1/5	
	HG-KR43(B)G7 1/11	400 W	3000 r/min	1/11	
	HG-KR43(B)G7 1/21	400 W	3000 r/min	1/21	
	HG-KR43(B)G7 1/33	400 W	3000 r/min	1/33	
	HG-KR43(B)G7 1/45	400 W	3000 r/min	1/45	
	HG-KR73(B)G7 1/5	750 W	3000 r/min	1/5	
	HG-KR73(B)G7 1/11	750 W	3000 r/min	1/11	
	HG-KR73(B)G7 1/21	750 W	3000 r/min	1/21	
	HG-KR73(B)G7 1/33	750 W	3000 r/min	1/33	
	HG-KR73(B)G7 1/45	750 W	3000 r/min	1/45	
HG-MR series  B: With electromagnetic brake	HG-MR053(B)	50 W	3000 r/min	-	
	HG-MR13(B)	100 W	3000 r/min	-	
	HG-MR23(B)	200 W	3000 r/min	-	
	HG-MR43(B)	400 W	3000 r/min	-	
	HG-MR73(B)	750 W	3000 r/min	-	
HG-SR 1000 r/min series  B: With electromagnetic brake	HG-SR51(B)	0.5 kW	1000 r/min	-	
	HG-SR81(B)	0.85 kW	1000 r/min	-	
	HG-SR121(B)	1.2 kW	1000 r/min	-	
	HG-SR201(B)	2.0 kW	1000 r/min	-	
	HG-SR301(B)	3.0 kW	1000 r/min	-	
	HG-SR421(B)	4.2 kW	1000 r/min	-	
Servo motors with functional safety HG-SR 1000 r/min series  B: With electromagnetic brake	HG-SR51(B)W0C	0.5 kW	1000 r/min	-	
	HG-SR81(B)W0C	0.85 kW	1000 r/min	-	
	HG-SR121(B)W0C	1.2 kW	1000 r/min	-	
	HG-SR201(B)W0C	2.0 kW	1000 r/min	-	
	HG-SR301(B)W0C	3.0 kW	1000 r/min	-	
	HG-SR421(B)W0C	4.2 kW	1000 r/min	-	
HG-SR 2000 r/min series  B: With electromagnetic brake	200 V class	HG-SR52(B)	0.5 kW	2000 r/min	-
		HG-SR102(B)	1.0 kW	2000 r/min	-
		HG-SR152(B)	1.5 kW	2000 r/min	-
		HG-SR202(B)	2.0 kW	2000 r/min	-
		HG-SR352(B)	3.5 kW	2000 r/min	-
		HG-SR502(B)	5.0 kW	2000 r/min	-
		HG-SR702(B)	7.0 kW	2000 r/min	-
	400 V class	HG-SR524(B)	0.5 kW	2000 r/min	-
		HG-SR1024(B)	1.0 kW	2000 r/min	-
		HG-SR1524(B)	1.5 kW	2000 r/min	-
		HG-SR2024(B)	2.0 kW	2000 r/min	-
		HG-SR3524(B)	3.5 kW	2000 r/min	-
		HG-SR5024(B)	5.0 kW	2000 r/min	-
		HG-SR7024(B)	7.0 kW	2000 r/min	-

Servo Amplifiers

Rotary Servo Motors

Linear Servo Motors

Direct Drive Motors

Options/Peripheral Equipment

LVS/Wires

Product List

Precautions

# Product List

## Rotary servo motors

Item	Model	Rated output	Rated speed	Reduction ratio	
Servo motors with functional safety HG-SR 2000 r/min series  B: With electromagnetic brake	200 V class	HG-SR52(B)W0C	0.5 kW	2000 r/min	-
		HG-SR102(B)W0C	1.0 kW	2000 r/min	-
		HG-SR152(B)W0C	1.5 kW	2000 r/min	-
		HG-SR202(B)W0C	2.0 kW	2000 r/min	-
		HG-SR352(B)W0C	3.5 kW	2000 r/min	-
		HG-SR502(B)W0C	5.0 kW	2000 r/min	-
		HG-SR702(B)W0C	7.0 kW	2000 r/min	-
	400 V class	HG-SR524(B)W0C	0.5 kW	2000 r/min	-
		HG-SR1024(B)W0C	1.0 kW	2000 r/min	-
		HG-SR1524(B)W0C	1.5 kW	2000 r/min	-
		HG-SR2024(B)W0C	2.0 kW	2000 r/min	-
		HG-SR3524(B)W0C	3.5 kW	2000 r/min	-
		HG-SR5024(B)W0C	5.0 kW	2000 r/min	-
		HG-SR7024(B)W0C	7.0 kW	2000 r/min	-
HG-SR 2000 r/min series With gear reducer for general industrial machines  B: With electromagnetic brake G1: Flange mounting G1H: Foot mounting	200 V class	HG-SR52(B)G1(H) 1/6	0.5 kW	2000 r/min	1/6
		HG-SR52(B)G1(H) 1/11	0.5 kW	2000 r/min	1/11
		HG-SR52(B)G1(H) 1/17	0.5 kW	2000 r/min	1/17
		HG-SR52(B)G1(H) 1/29	0.5 kW	2000 r/min	1/29
		HG-SR52(B)G1(H) 1/35	0.5 kW	2000 r/min	1/35
		HG-SR52(B)G1(H) 1/43	0.5 kW	2000 r/min	1/43
		HG-SR52(B)G1(H) 1/59	0.5 kW	2000 r/min	1/59
		HG-SR102(B)G1(H) 1/6	1.0 kW	2000 r/min	1/6
		HG-SR102(B)G1(H) 1/11	1.0 kW	2000 r/min	1/11
		HG-SR102(B)G1(H) 1/17	1.0 kW	2000 r/min	1/17
		HG-SR102(B)G1(H) 1/29	1.0 kW	2000 r/min	1/29
		HG-SR102(B)G1(H) 1/35	1.0 kW	2000 r/min	1/35
		HG-SR102(B)G1(H) 1/43	1.0 kW	2000 r/min	1/43
		HG-SR102(B)G1(H) 1/59	1.0 kW	2000 r/min	1/59
		HG-SR152(B)G1(H) 1/6	1.5 kW	2000 r/min	1/6
		HG-SR152(B)G1(H) 1/11	1.5 kW	2000 r/min	1/11
		HG-SR152(B)G1(H) 1/17	1.5 kW	2000 r/min	1/17
		HG-SR152(B)G1(H) 1/29	1.5 kW	2000 r/min	1/29
		HG-SR152(B)G1(H) 1/35	1.5 kW	2000 r/min	1/35
		HG-SR152(B)G1(H) 1/43	1.5 kW	2000 r/min	1/43
		HG-SR152(B)G1(H) 1/59	1.5 kW	2000 r/min	1/59
		HG-SR202(B)G1(H) 1/6	2.0 kW	2000 r/min	1/6
		HG-SR202(B)G1(H) 1/11	2.0 kW	2000 r/min	1/11
		HG-SR202(B)G1(H) 1/17	2.0 kW	2000 r/min	1/17
		HG-SR202(B)G1(H) 1/29	2.0 kW	2000 r/min	1/29
		HG-SR202(B)G1(H) 1/35	2.0 kW	2000 r/min	1/35
		HG-SR202(B)G1(H) 1/43	2.0 kW	2000 r/min	1/43
		HG-SR202(B)G1(H) 1/59	2.0 kW	2000 r/min	1/59
		HG-SR352(B)G1(H) 1/6	3.5 kW	2000 r/min	1/6
		HG-SR352(B)G1(H) 1/11	3.5 kW	2000 r/min	1/11
		HG-SR352(B)G1(H) 1/17	3.5 kW	2000 r/min	1/17
		HG-SR352(B)G1(H) 1/29	3.5 kW	2000 r/min	1/29
		HG-SR352(B)G1(H) 1/35	3.5 kW	2000 r/min	1/35
		HG-SR352(B)G1(H) 1/43	3.5 kW	2000 r/min	1/43
		HG-SR352(B)G1(H) 1/59	3.5 kW	2000 r/min	1/59
		HG-SR502(B)G1(H) 1/6	5.0 kW	2000 r/min	1/6
		HG-SR502(B)G1(H) 1/11	5.0 kW	2000 r/min	1/11
		HG-SR502(B)G1(H) 1/17	5.0 kW	2000 r/min	1/17
		HG-SR502(B)G1(H) 1/29	5.0 kW	2000 r/min	1/29
		HG-SR502(B)G1(H) 1/35	5.0 kW	2000 r/min	1/35
		HG-SR502(B)G1(H) 1/43	5.0 kW	2000 r/min	1/43
		HG-SR502(B)G1(H) 1/59	5.0 kW	2000 r/min	1/59

Rotary servo motors

Item	Model	Rated output	Rated speed	Reduction ratio	
HG-SR 2000 r/min series With gear reducer for general industrial machines  B: With electromagnetic brake G1: Flange mounting G1H: Foot mounting	200 V class	HG-SR702(B)G1(H) 1/6	7.0 kW	2000 r/min	1/6
		HG-SR702(B)G1(H) 1/11	7.0 kW	2000 r/min	1/11
		HG-SR702(B)G1(H) 1/17	7.0 kW	2000 r/min	1/17
		HG-SR702(B)G1(H) 1/29	7.0 kW	2000 r/min	1/29
		HG-SR702(B)G1(H) 1/35	7.0 kW	2000 r/min	1/35
		HG-SR702(B)G1(H) 1/43	7.0 kW	2000 r/min	1/43
	HG-SR702(B)G1(H) 1/59	7.0 kW	2000 r/min	1/59	
	400 V class	HG-SR524(B)G1(H) 1/6	0.5 kW	2000 r/min	1/6
		HG-SR524(B)G1(H) 1/11	0.5 kW	2000 r/min	1/11
		HG-SR524(B)G1(H) 1/17	0.5 kW	2000 r/min	1/17
		HG-SR524(B)G1(H) 1/29	0.5 kW	2000 r/min	1/29
		HG-SR524(B)G1(H) 1/35	0.5 kW	2000 r/min	1/35
		HG-SR524(B)G1(H) 1/43	0.5 kW	2000 r/min	1/43
		HG-SR524(B)G1(H) 1/59	0.5 kW	2000 r/min	1/59
		HG-SR1024(B)G1(H) 1/6	1.0 kW	2000 r/min	1/6
		HG-SR1024(B)G1(H) 1/11	1.0 kW	2000 r/min	1/11
		HG-SR1024(B)G1(H) 1/17	1.0 kW	2000 r/min	1/17
		HG-SR1024(B)G1(H) 1/29	1.0 kW	2000 r/min	1/29
		HG-SR1024(B)G1(H) 1/35	1.0 kW	2000 r/min	1/35
		HG-SR1024(B)G1(H) 1/43	1.0 kW	2000 r/min	1/43
		HG-SR1024(B)G1(H) 1/59	1.0 kW	2000 r/min	1/59
		HG-SR1524(B)G1(H) 1/6	1.5 kW	2000 r/min	1/6
		HG-SR1524(B)G1(H) 1/11	1.5 kW	2000 r/min	1/11
		HG-SR1524(B)G1(H) 1/17	1.5 kW	2000 r/min	1/17
		HG-SR1524(B)G1(H) 1/29	1.5 kW	2000 r/min	1/29
		HG-SR1524(B)G1(H) 1/35	1.5 kW	2000 r/min	1/35
		HG-SR1524(B)G1(H) 1/43	1.5 kW	2000 r/min	1/43
		HG-SR1524(B)G1(H) 1/59	1.5 kW	2000 r/min	1/59
		HG-SR2024(B)G1(H) 1/6	2.0 kW	2000 r/min	1/6
		HG-SR2024(B)G1(H) 1/11	2.0 kW	2000 r/min	1/11
		HG-SR2024(B)G1(H) 1/17	2.0 kW	2000 r/min	1/17
		HG-SR2024(B)G1(H) 1/29	2.0 kW	2000 r/min	1/29
		HG-SR2024(B)G1(H) 1/35	2.0 kW	2000 r/min	1/35
		HG-SR2024(B)G1(H) 1/43	2.0 kW	2000 r/min	1/43
		HG-SR2024(B)G1(H) 1/59	2.0 kW	2000 r/min	1/59
		HG-SR3524(B)G1(H) 1/6	3.5 kW	2000 r/min	1/6
		HG-SR3524(B)G1(H) 1/11	3.5 kW	2000 r/min	1/11
		HG-SR3524(B)G1(H) 1/17	3.5 kW	2000 r/min	1/17
		HG-SR3524(B)G1(H) 1/29	3.5 kW	2000 r/min	1/29
		HG-SR3524(B)G1(H) 1/35	3.5 kW	2000 r/min	1/35
		HG-SR3524(B)G1(H) 1/43	3.5 kW	2000 r/min	1/43
		HG-SR3524(B)G1(H) 1/59	3.5 kW	2000 r/min	1/59
HG-SR5024(B)G1(H) 1/6		5.0 kW	2000 r/min	1/6	
HG-SR5024(B)G1(H) 1/11	5.0 kW	2000 r/min	1/11		
HG-SR5024(B)G1(H) 1/17	5.0 kW	2000 r/min	1/17		
HG-SR5024(B)G1(H) 1/29	5.0 kW	2000 r/min	1/29		
HG-SR5024(B)G1(H) 1/35	5.0 kW	2000 r/min	1/35		
HG-SR5024(B)G1(H) 1/43	5.0 kW	2000 r/min	1/43		
HG-SR5024(B)G1(H) 1/59	5.0 kW	2000 r/min	1/59		
HG-SR7024(B)G1(H) 1/6	7.0 kW	2000 r/min	1/6		
HG-SR7024(B)G1(H) 1/11	7.0 kW	2000 r/min	1/11		
HG-SR7024(B)G1(H) 1/17	7.0 kW	2000 r/min	1/17		
HG-SR7024(B)G1(H) 1/29	7.0 kW	2000 r/min	1/29		
HG-SR7024(B)G1(H) 1/35	7.0 kW	2000 r/min	1/35		
HG-SR7024(B)G1(H) 1/43	7.0 kW	2000 r/min	1/43		
HG-SR7024(B)G1(H) 1/59	7.0 kW	2000 r/min	1/59		

Servo Amplifiers

Rotary Servo Motors

Linear Servo Motors

Direct Drive Motors

Options/Peripheral Equipment

LVS/Wires

Product List

Precautions

# Product List

## Rotary servo motors

Item	Model	Rated output	Rated speed	Reduction ratio	
HG-SR 2000 r/min series With flange-output type gear reducer for high precision applications, flange mounting  B: With electromagnetic brake	200 V class	HG-SR52(B)G5 1/5	0.5 kW	2000 r/min	1/5
		HG-SR52(B)G5 1/11	0.5 kW	2000 r/min	1/11
		HG-SR52(B)G5 1/21	0.5 kW	2000 r/min	1/21
		HG-SR52(B)G5 1/33	0.5 kW	2000 r/min	1/33
		HG-SR52(B)G5 1/45	0.5 kW	2000 r/min	1/45
		HG-SR102(B)G5 1/5	1.0 kW	2000 r/min	1/5
		HG-SR102(B)G5 1/11	1.0 kW	2000 r/min	1/11
		HG-SR102(B)G5 1/21	1.0 kW	2000 r/min	1/21
		HG-SR102(B)G5 1/33	1.0 kW	2000 r/min	1/33
		HG-SR102(B)G5 1/45	1.0 kW	2000 r/min	1/45
		HG-SR152(B)G5 1/5	1.5 kW	2000 r/min	1/5
		HG-SR152(B)G5 1/11	1.5 kW	2000 r/min	1/11
		HG-SR152(B)G5 1/21	1.5 kW	2000 r/min	1/21
		HG-SR152(B)G5 1/33	1.5 kW	2000 r/min	1/33
		HG-SR152(B)G5 1/45	1.5 kW	2000 r/min	1/45
		HG-SR202(B)G5 1/5	2.0 kW	2000 r/min	1/5
		HG-SR202(B)G5 1/11	2.0 kW	2000 r/min	1/11
		HG-SR202(B)G5 1/21	2.0 kW	2000 r/min	1/21
		HG-SR202(B)G5 1/33	2.0 kW	2000 r/min	1/33
		HG-SR202(B)G5 1/45	2.0 kW	2000 r/min	1/45
		HG-SR352(B)G5 1/5	3.5 kW	2000 r/min	1/5
	HG-SR352(B)G5 1/11	3.5 kW	2000 r/min	1/11	
	HG-SR352(B)G5 1/21	3.5 kW	2000 r/min	1/21	
	HG-SR502(B)G5 1/5	5.0 kW	2000 r/min	1/5	
	HG-SR502(B)G5 1/11	5.0 kW	2000 r/min	1/11	
	HG-SR702(B)G5 1/5	7.0 kW	2000 r/min	1/5	
	400 V class	HG-SR524(B)G5 1/5	0.5 kW	2000 r/min	1/5
		HG-SR524(B)G5 1/11	0.5 kW	2000 r/min	1/11
		HG-SR524(B)G5 1/21	0.5 kW	2000 r/min	1/21
		HG-SR524(B)G5 1/33	0.5 kW	2000 r/min	1/33
		HG-SR524(B)G5 1/45	0.5 kW	2000 r/min	1/45
		HG-SR1024(B)G5 1/5	1.0 kW	2000 r/min	1/5
		HG-SR1024(B)G5 1/11	1.0 kW	2000 r/min	1/11
		HG-SR1024(B)G5 1/21	1.0 kW	2000 r/min	1/21
		HG-SR1024(B)G5 1/33	1.0 kW	2000 r/min	1/33
		HG-SR1024(B)G5 1/45	1.0 kW	2000 r/min	1/45
		HG-SR1524(B)G5 1/5	1.5 kW	2000 r/min	1/5
		HG-SR1524(B)G5 1/11	1.5 kW	2000 r/min	1/11
		HG-SR1524(B)G5 1/21	1.5 kW	2000 r/min	1/21
		HG-SR1524(B)G5 1/33	1.5 kW	2000 r/min	1/33
		HG-SR1524(B)G5 1/45	1.5 kW	2000 r/min	1/45
		HG-SR2024(B)G5 1/5	2.0 kW	2000 r/min	1/5
HG-SR2024(B)G5 1/11		2.0 kW	2000 r/min	1/11	
HG-SR2024(B)G5 1/21		2.0 kW	2000 r/min	1/21	
HG-SR2024(B)G5 1/33		2.0 kW	2000 r/min	1/33	
HG-SR2024(B)G5 1/45		2.0 kW	2000 r/min	1/45	
HG-SR3524(B)G5 1/5		3.5 kW	2000 r/min	1/5	
HG-SR3524(B)G5 1/11	3.5 kW	2000 r/min	1/11		
HG-SR3524(B)G5 1/21	3.5 kW	2000 r/min	1/21		
HG-SR5024(B)G5 1/5	5.0 kW	2000 r/min	1/5		
HG-SR5024(B)G5 1/11	5.0 kW	2000 r/min	1/11		
HG-SR7024(B)G5 1/5	7.0 kW	2000 r/min	1/5		

Rotary servo motors

Item	Model	Rated output	Rated speed	Reduction ratio	
HG-SR 2000 r/min series With shaft-output type gear reducer for high precision applications, flange mounting  B: With electromagnetic brake	200 V class	HG-SR52(B)G7 1/5	0.5 kW	2000 r/min	1/5
		HG-SR52(B)G7 1/11	0.5 kW	2000 r/min	1/11
		HG-SR52(B)G7 1/21	0.5 kW	2000 r/min	1/21
		HG-SR52(B)G7 1/33	0.5 kW	2000 r/min	1/33
		HG-SR52(B)G7 1/45	0.5 kW	2000 r/min	1/45
		HG-SR102(B)G7 1/5	1.0 kW	2000 r/min	1/5
		HG-SR102(B)G7 1/11	1.0 kW	2000 r/min	1/11
		HG-SR102(B)G7 1/21	1.0 kW	2000 r/min	1/21
		HG-SR102(B)G7 1/33	1.0 kW	2000 r/min	1/33
		HG-SR102(B)G7 1/45	1.0 kW	2000 r/min	1/45
		HG-SR152(B)G7 1/5	1.5 kW	2000 r/min	1/5
		HG-SR152(B)G7 1/11	1.5 kW	2000 r/min	1/11
		HG-SR152(B)G7 1/21	1.5 kW	2000 r/min	1/21
		HG-SR152(B)G7 1/33	1.5 kW	2000 r/min	1/33
		HG-SR152(B)G7 1/45	1.5 kW	2000 r/min	1/45
		HG-SR202(B)G7 1/5	2.0 kW	2000 r/min	1/5
		HG-SR202(B)G7 1/11	2.0 kW	2000 r/min	1/11
		HG-SR202(B)G7 1/21	2.0 kW	2000 r/min	1/21
		HG-SR202(B)G7 1/33	2.0 kW	2000 r/min	1/33
		HG-SR202(B)G7 1/45	2.0 kW	2000 r/min	1/45
		HG-SR352(B)G7 1/5	3.5 kW	2000 r/min	1/5
	HG-SR352(B)G7 1/11	3.5 kW	2000 r/min	1/11	
	HG-SR352(B)G7 1/21	3.5 kW	2000 r/min	1/21	
	HG-SR502(B)G7 1/5	5.0 kW	2000 r/min	1/5	
	HG-SR502(B)G7 1/11	5.0 kW	2000 r/min	1/11	
	HG-SR702(B)G7 1/5	7.0 kW	2000 r/min	1/5	
	400 V class	HG-SR524(B)G7 1/5	0.5 kW	2000 r/min	1/5
		HG-SR524(B)G7 1/11	0.5 kW	2000 r/min	1/11
		HG-SR524(B)G7 1/21	0.5 kW	2000 r/min	1/21
		HG-SR524(B)G7 1/33	0.5 kW	2000 r/min	1/33
		HG-SR524(B)G7 1/45	0.5 kW	2000 r/min	1/45
		HG-SR1024(B)G7 1/5	1.0 kW	2000 r/min	1/5
		HG-SR1024(B)G7 1/11	1.0 kW	2000 r/min	1/11
		HG-SR1024(B)G7 1/21	1.0 kW	2000 r/min	1/21
		HG-SR1024(B)G7 1/33	1.0 kW	2000 r/min	1/33
		HG-SR1024(B)G7 1/45	1.0 kW	2000 r/min	1/45
		HG-SR1524(B)G7 1/5	1.5 kW	2000 r/min	1/5
		HG-SR1524(B)G7 1/11	1.5 kW	2000 r/min	1/11
		HG-SR1524(B)G7 1/21	1.5 kW	2000 r/min	1/21
		HG-SR1524(B)G7 1/33	1.5 kW	2000 r/min	1/33
		HG-SR1524(B)G7 1/45	1.5 kW	2000 r/min	1/45
		HG-SR2024(B)G7 1/5	2.0 kW	2000 r/min	1/5
HG-SR2024(B)G7 1/11		2.0 kW	2000 r/min	1/11	
HG-SR2024(B)G7 1/21		2.0 kW	2000 r/min	1/21	
HG-SR2024(B)G7 1/33		2.0 kW	2000 r/min	1/33	
HG-SR2024(B)G7 1/45		2.0 kW	2000 r/min	1/45	
HG-SR3524(B)G7 1/5		3.5 kW	2000 r/min	1/5	
HG-SR3524(B)G7 1/11	3.5 kW	2000 r/min	1/11		
HG-SR3524(B)G7 1/21	3.5 kW	2000 r/min	1/21		
HG-SR5024(B)G7 1/5	5.0 kW	2000 r/min	1/5		
HG-SR5024(B)G7 1/11	5.0 kW	2000 r/min	1/11		
HG-SR7024(B)G7 1/5	7.0 kW	2000 r/min	1/5		

Servo Amplifiers

Rotary Servo Motors

Linear Servo Motors

Direct Drive Motors

Options/Peripheral Equipment

LVS/Wires

Product List

Precautions

# Product List

## Rotary servo motors

Item	Model	Rated output	Rated speed	Reduction ratio	
HG-JR 1000 r/min series B: With electromagnetic brake	200 V class	HG-JR601(B)	6.0 kW	1000 r/min	-
		HG-JR801(B)	8.0 kW	1000 r/min	-
		HG-JR12K1(B)	12 kW	1000 r/min	-
		HG-JR15K1	15 kW	1000 r/min	-
		HG-JR20K1	20 kW	1000 r/min	-
		HG-JR25K1	25 kW	1000 r/min	-
		HG-JR30K1	30 kW	1000 r/min	-
		HG-JR37K1	37 kW	1000 r/min	-
	400 V class	HG-JR6014(B)	6.0 kW	1000 r/min	-
		HG-JR8014(B)	8.0 kW	1000 r/min	-
		HG-JR12K14(B)	12 kW	1000 r/min	-
		HG-JR15K14	15 kW	1000 r/min	-
		HG-JR20K14	20 kW	1000 r/min	-
		HG-JR25K14	25 kW	1000 r/min	-
	HG-JR30K14	30 kW	1000 r/min	-	
	HG-JR37K14	37 kW	1000 r/min	-	
HG-JR 1500 r/min series B: With electromagnetic brake	200 V class	HG-JR701M(B)	7.0 kW	1500 r/min	-
		HG-JR11K1M(B)	11 kW	1500 r/min	-
		HG-JR15K1M(B)	15 kW	1500 r/min	-
		HG-JR22K1M	22 kW	1500 r/min	-
		HG-JR30K1M	30 kW	1500 r/min	-
		HG-JR37K1M	37 kW	1500 r/min	-
	400 V class	HG-JR701M4(B)	7.0 kW	1500 r/min	-
		HG-JR11K1M4(B)	11 kW	1500 r/min	-
		HG-JR15K1M4(B)	15 kW	1500 r/min	-
		HG-JR22K1M4	22 kW	1500 r/min	-
		HG-JR30K1M4	30 kW	1500 r/min	-
		HG-JR37K1M4	37 kW	1500 r/min	-
		HG-JR45K1M4	45 kW	1500 r/min	-
		HG-JR55K1M4	55 kW	1500 r/min	-
Servo motors with functional safety HG-JR 1500 r/min series B: With electromagnetic brake	200 V class	HG-JR701M(B)W0C	7.0 kW	1500 r/min	-
		HG-JR11K1M(B)W0C	11 kW	1500 r/min	-
		HG-JR15K1M(B)W0C	15 kW	1500 r/min	-
		HG-JR22K1MW0C	22 kW	1500 r/min	-
	400 V class	HG-JR701M4(B)W0C	7.0 kW	1500 r/min	-
		HG-JR11K1M4(B)W0C	11 kW	1500 r/min	-
		HG-JR15K1M4(B)W0C	15 kW	1500 r/min	-
		HG-JR22K1M4W0C	22 kW	1500 r/min	-
Servo motors with functional safety HG-JR 2000 r/min series	400 V class	HG-JR110K24W0C	110 kW	2000 r/min	-
		HG-JR150K24W0C	150 kW	2000 r/min	-
		HG-JR180K24W0C	180 kW	2000 r/min	-
		HG-JR200K24W0C	200 kW	2000 r/min	-
		HG-JR220K24W0C	220 kW	2000 r/min	-



Rotary servo motors

Item	Model	Rated output	Rated speed	Reduction ratio	
HG-JR 3000 r/min series B: With electromagnetic brake	200 V class	HG-JR53(B)	0.5 kW	3000 r/min	-
		HG-JR73(B)	0.75 kW	3000 r/min	-
		HG-JR103(B)	1.0 kW	3000 r/min	-
		HG-JR153(B)	1.5 kW	3000 r/min	-
		HG-JR203(B)	2.0 kW	3000 r/min	-
		HG-JR353(B)	3.3 kW (3.5 kW)	3000 r/min	-
		HG-JR503(B)	5.0 kW	3000 r/min	-
		HG-JR703(B)	7.0 kW	3000 r/min	-
	HG-JR903(B)	9.0 kW	3000 r/min	-	
	400 V class	HG-JR534(B)	0.5 kW	3000 r/min	-
		HG-JR734(B)	0.75 kW	3000 r/min	-
		HG-JR1034(B)	1.0 kW	3000 r/min	-
		HG-JR1534(B)	1.5 kW	3000 r/min	-
		HG-JR2034(B)	2.0 kW	3000 r/min	-
		HG-JR3534(B)	3.3 kW (3.5 kW)	3000 r/min	-
		HG-JR5034(B)	5.0 kW	3000 r/min	-
HG-JR7034(B)		7.0 kW	3000 r/min	-	
HG-JR9034(B)	9.0 kW	3000 r/min	-		
Servo motors with functional safety HG-JR 3000 r/min series B: With electromagnetic brake	200 V class	HG-JR53(B)W0C	0.5 kW	3000 r/min	-
		HG-JR73(B)W0C	0.75 kW	3000 r/min	-
		HG-JR103(B)W0C	1.0 kW	3000 r/min	-
		HG-JR153(B)W0C	1.5 kW	3000 r/min	-
		HG-JR203(B)W0C	2.0 kW	3000 r/min	-
		HG-JR353(B)W0C	3.3 kW (3.5 kW)	3000 r/min	-
		HG-JR503(B)W0C	5.0 kW	3000 r/min	-
		HG-JR703(B)W0C	7.0 kW	3000 r/min	-
		HG-JR903(B)W0C	9.0 kW	3000 r/min	-
	400 V class	HG-JR534(B)W0C	0.5 kW	3000 r/min	-
		HG-JR734(B)W0C	0.75 kW	3000 r/min	-
		HG-JR1034(B)W0C	1.0 kW	3000 r/min	-
		HG-JR1534(B)W0C	1.5 kW	3000 r/min	-
		HG-JR2034(B)W0C	2.0 kW	3000 r/min	-
		HG-JR3534(B)W0C	3.3 kW (3.5 kW)	3000 r/min	-
		HG-JR5034(B)W0C	5.0 kW	3000 r/min	-
		HG-JR7034(B)W0C	7.0 kW	3000 r/min	-
		HG-JR9034(B)W0C	9.0 kW	3000 r/min	-
HG-RR series B: With electromagnetic brake	HG-RR103(B)	1.0 kW	3000 r/min	-	
	HG-RR153(B)	1.5 kW	3000 r/min	-	
	HG-RR203(B)	2.0 kW	3000 r/min	-	
	HG-RR353(B)	3.5 kW	3000 r/min	-	
	HG-RR503(B)	5.0 kW	3000 r/min	-	
HG-UR series B: With electromagnetic brake	HG-UR72(B)	0.75 kW	2000 r/min	-	
	HG-UR152(B)	1.5 kW	2000 r/min	-	
	HG-UR202(B)	2.0 kW	2000 r/min	-	
	HG-UR352(B)	3.5 kW	2000 r/min	-	
	HG-UR502(B)	5.0 kW	2000 r/min	-	
HG-AK series B: With electromagnetic brake	HG-AK0136(B)	10 W	3000 r/min	-	
	HG-AK0236(B)	20 W	3000 r/min	-	
	HG-AK0336(B)	30 W	3000 r/min	-	
HG-AK series B: With electromagnetic brake With a vertical encoder cable lead	HG-AK0136(B)-S100	10 W	3000 r/min	-	
	HG-AK0236(B)-S100	20 W	3000 r/min	-	
	HG-AK0336(B)-S100	30 W	3000 r/min	-	

Servo Amplifiers

Rotary Servo Motors

Linear Servo Motors

Direct Drive Motors

Options/Peripheral Equipment

LVS/Wires

Product List

Precautions

# Product List

## Linear servo motors

Item	Model	Continuous thrust	Maximum thrust	Maximum speed	Length	
LM-H3 series Primary side (coil)	LM-H3P2A-07P-BSS0	70 N	175 N	3.0 m/s	-	
	LM-H3P3A-12P-CSS0	120 N	300 N	3.0 m/s	-	
	LM-H3P3B-24P-CSS0	240 N	600 N	3.0 m/s	-	
	LM-H3P3C-36P-CSS0	360 N	900 N	3.0 m/s	-	
	LM-H3P3D-48P-CSS0	480 N	1200 N	3.0 m/s	-	
	LM-H3P7A-24P-ASS0	240 N	600 N	3.0 m/s	-	
	LM-H3P7B-48P-ASS0	480 N	1200 N	3.0 m/s	-	
	LM-H3P7C-72P-ASS0	720 N	1800 N	3.0 m/s	-	
	LM-H3P7D-96P-ASS0	960 N	2400 N	3.0 m/s	-	
LM-H3 series Secondary side (magnet)	LM-H3S20-288-BSS0	-	-	-	288 mm	
	LM-H3S20-384-BSS0	-	-	-	384 mm	
	LM-H3S20-480-BSS0	-	-	-	480 mm	
	LM-H3S20-768-BSS0	-	-	-	768 mm	
	LM-H3S30-288-CSS0	-	-	-	288 mm	
	LM-H3S30-384-CSS0	-	-	-	384 mm	
	LM-H3S30-480-CSS0	-	-	-	480 mm	
	LM-H3S30-768-CSS0	-	-	-	768 mm	
	LM-H3S70-288-ASS0	-	-	-	288 mm	
	LM-H3S70-384-ASS0	-	-	-	384 mm	
	LM-H3S70-480-ASS0	-	-	-	480 mm	
	LM-H3S70-768-ASS0	-	-	-	768 mm	
LM-F series Primary side (coil)	200 V class	LM-FP2B-06M-1SS0	300 N (natural cooling) /600 N (liquid cooling)	1800 N	2.0 m/s	-
		LM-FP2D-12M-1SS0	600 N (natural cooling) /1200 N (liquid cooling)	3600 N	2.0 m/s	-
		LM-FP2F-18M-1SS0	900 N (natural cooling) /1800 N (liquid cooling)	5400 N	2.0 m/s	-
		LM-FP4B-12M-1SS0	600 N (natural cooling) /1200 N (liquid cooling)	3600 N	2.0 m/s	-
		LM-FP4D-24M-1SS0	1200 N (natural cooling) /2400 N (liquid cooling)	7200 N	2.0 m/s	-
		LM-FP4F-36M-1SS0	1800 N (natural cooling) /3600 N (liquid cooling)	10800 N	2.0 m/s	-
	LM-FP4H-48M-1SS0	2400 N (natural cooling) /4800 N (liquid cooling)	14400 N	2.0 m/s	-	
	400 V class	LM-FP5H-60M-1SS0	3000 N (natural cooling) /6000 N (liquid cooling)	18000 N	2.0 m/s	-
LM-F series Secondary side (magnet)	200 V class	LM-FS20-480-1SS0	-	-	-	480 mm
		LM-FS20-576-1SS0	-	-	-	576 mm
		LM-FS40-480-1SS0	-	-	-	480 mm
		LM-FS40-576-1SS0	-	-	-	576 mm
	400 V class	LM-FS50-480-1SS0	-	-	-	480 mm
		LM-FS50-576-1SS0	-	-	-	576 mm
LM-K2 series Primary side (coil)		LM-K2P1A-01M-2SS1	120 N	300 N	2.0 m/s	-
		LM-K2P1C-03M-2SS1	360 N	900 N	2.0 m/s	-
		LM-K2P2A-02M-1SS1	240 N	600 N	2.0 m/s	-
		LM-K2P2C-07M-1SS1	720 N	1800 N	2.0 m/s	-
		LM-K2P2E-12M-1SS1	1200 N	3000 N	2.0 m/s	-
		LM-K2P3C-14M-1SS1	1440 N	3600 N	2.0 m/s	-
		LM-K2P3E-24M-1SS1	2400 N	6000 N	2.0 m/s	-
LM-K2 series Secondary side (magnet)		LM-K2S10-288-2SS1	-	-	-	288 mm
		LM-K2S10-384-2SS1	-	-	-	384 mm
		LM-K2S10-480-2SS1	-	-	-	480 mm
		LM-K2S10-768-2SS1	-	-	-	768 mm
		LM-K2S20-288-1SS1	-	-	-	288 mm
		LM-K2S20-384-1SS1	-	-	-	384 mm
		LM-K2S20-480-1SS1	-	-	-	480 mm
		LM-K2S20-768-1SS1	-	-	-	768 mm
		LM-K2S30-288-1SS1	-	-	-	288 mm
		LM-K2S30-384-1SS1	-	-	-	384 mm
		LM-K2S30-480-1SS1	-	-	-	480 mm
	LM-K2S30-768-1SS1	-	-	-	768 mm	

Linear servo motors

Item	Model	Continuous thrust	Maximum thrust	Maximum speed	Length
LM-U2 series Primary side (coil)	LM-U2PAB-05M-0SS0	50 N	150 N	2.0 m/s	-
	LM-U2PAD-10M-0SS0	100 N	300 N	2.0 m/s	-
	LM-U2PAF-15M-0SS0	150 N	450 N	2.0 m/s	-
	LM-U2PBB-07M-1SS0	75 N	225 N	2.0 m/s	-
	LM-U2PBD-15M-1SS0	150 N	450 N	2.0 m/s	-
	LM-U2PBF-22M-1SS0	225 N	675 N	2.0 m/s	-
	LM-U2P2B-40M-2SS0	400 N	1600 N	2.0 m/s	-
	LM-U2P2C-60M-2SS0	600 N	2400 N	2.0 m/s	-
	LM-U2P2D-80M-2SS0	800 N	3200 N	2.0 m/s	-
LM-U2 series Secondary side (magnet)	LM-U2SA0-240-0SS0	-	-	-	240 mm
	LM-U2SA0-300-0SS0	-	-	-	300 mm
	LM-U2SA0-420-0SS0	-	-	-	420 mm
	LM-U2SB0-240-1SS1	-	-	-	240 mm
	LM-U2SB0-300-1SS1	-	-	-	300 mm
	LM-U2SB0-420-1SS1	-	-	-	420 mm
	LM-U2S20-300-2SS1	-	-	-	300 mm
	LM-U2S20-480-2SS1	-	-	-	480 mm

Direct drive motors

Item	Model	Rated torque	Maximum torque	Rated speed
TM-RG2M series	TM-RG2M002C30	2.2 N•m	8.8 N•m	300 r/min
	TM-RG2M004E30	4.5 N•m	13.5 N•m	300 r/min
	TM-RG2M009G30	9 N•m	27 N•m	300 r/min
TM-RU2M series	TM-RU2M002C30	2.2 N•m	8.8 N•m	300 r/min
	TM-RU2M004E30	4.5 N•m	13.5 N•m	300 r/min
	TM-RU2M009G30	9 N•m	27 N•m	300 r/min
TM-RFM series	TM-RFM002C20	2 N•m	6 N•m	200 r/min
	TM-RFM004C20	4 N•m	12 N•m	200 r/min
	TM-RFM006C20	6 N•m	18 N•m	200 r/min
	TM-RFM006E20	6 N•m	18 N•m	200 r/min
	TM-RFM012E20	12 N•m	36 N•m	200 r/min
	TM-RFM018E20	18 N•m	54 N•m	200 r/min
	TM-RFM012G20	12 N•m	36 N•m	200 r/min
	TM-RFM048G20	48 N•m	144 N•m	200 r/min
	TM-RFM072G20	72 N•m	216 N•m	200 r/min
	TM-RFM040J10	40 N•m	120 N•m	100 r/min
	TM-RFM120J10	120 N•m	360 N•m	100 r/min
	TM-RFM240J10	240 N•m	720 N•m	100 r/min

Servo Amplifiers

Rotary Servo Motors

Linear Servo Motors

Direct Drive Motors

Options/Peripheral Equipment

LVS/Wires

Product List

Precautions

# Product List

## Encoder cables

Item	Model	Length	Bending life	IP rating	Application
Encoder cable (load-side lead)	MR-J3ENCBL2M-A1-H	2 m	Long bending life	IP65	For HG-KR/HG-MR (direct connection type)
	MR-J3ENCBL5M-A1-H	5 m	Long bending life	IP65	For HG-KR/HG-MR (direct connection type)
	MR-J3ENCBL10M-A1-H	10 m	Long bending life	IP65	For HG-KR/HG-MR (direct connection type)
	MR-J3ENCBL2M-A1-L	2 m	Standard	IP65	For HG-KR/HG-MR (direct connection type)
	MR-J3ENCBL5M-A1-L	5 m	Standard	IP65	For HG-KR/HG-MR (direct connection type)
Encoder cable (opposite to load-side lead)	MR-J3ENCBL2M-A2-H	2 m	Long bending life	IP65	For HG-KR/HG-MR (direct connection type)
	MR-J3ENCBL5M-A2-H	5 m	Long bending life	IP65	For HG-KR/HG-MR (direct connection type)
	MR-J3ENCBL10M-A2-H	10 m	Long bending life	IP65	For HG-KR/HG-MR (direct connection type)
	MR-J3ENCBL2M-A2-L	2 m	Standard	IP65	For HG-KR/HG-MR (direct connection type)
	MR-J3ENCBL5M-A2-L	5 m	Standard	IP65	For HG-KR/HG-MR (direct connection type)
Encoder cable (load-side lead)	MR-J3JCBL03M-A1-L	0.3 m	Standard	IP20	For HG-KR/HG-MR (junction type) <sup>(Note 1)</sup>
Encoder cable (opposite to load-side lead)	MR-J3JCBL03M-A2-L	0.3 m	Standard	IP20	For HG-KR/HG-MR (junction type) <sup>(Note 1)</sup>
Encoder cable	MR-EKCB20M-H	20 m	Long bending life	IP20	For HG-KR/HG-MR (junction type) <sup>(Note 2)</sup>
	MR-EKCB30M-H	30 m	Long bending life	IP20	For HG-KR/HG-MR (junction type) <sup>(Note 2)</sup>
	MR-EKCB40M-H	40 m	Long bending life	IP20	For HG-KR/HG-MR (junction type) <sup>(Note 2)</sup>
	MR-EKCB50M-H	50 m	Long bending life	IP20	For HG-KR/HG-MR (junction type) <sup>(Note 2)</sup>
	MR-EKCB20M-L	20 m	Standard	IP20	For HG-KR/HG-MR (junction type) <sup>(Note 2)</sup>
	MR-EKCB30M-L	30 m	Standard	IP20	For HG-KR/HG-MR (junction type) <sup>(Note 2)</sup>
	MR-EKCB2M-H	2 m	Long bending life	IP20	For connecting load-side encoder or linear encoder
Encoder cable (load-side lead)	MR-EKCB5M-H	5 m	Long bending life	IP20	For connecting load-side encoder or linear encoder
	MR-J3JSCBL03M-A1-L	0.3 m	Standard	IP65	For HG-KR/HG-MR (junction type) <sup>(Note 3)</sup>
Encoder cable (opposite to load-side lead)	MR-J3JSCBL03M-A2-L	0.3 m	Standard	IP65	For HG-KR/HG-MR (junction type) <sup>(Note 3)</sup>
Encoder cable	MR-J3ENSCBL2M-H	2 m	Long bending life	IP67	For HG-KR/HG-MR (junction type) <sup>(Note 4)</sup> , For HG-SR/HG-JR53(4), 73(4), 103(4), 153(4), 203(4), 353(4), 503(4), 703(4), 903(4)/ HG-RR/HG-UR (direct connection type)
	MR-J3ENSCBL5M-H	5 m	Long bending life	IP67	
	MR-J3ENSCBL10M-H	10 m	Long bending life	IP67	
	MR-J3ENSCBL20M-H	20 m	Long bending life	IP67	
	MR-J3ENSCBL30M-H	30 m	Long bending life	IP67	
	MR-J3ENSCBL40M-H	40 m	Long bending life	IP67	
	MR-J3ENSCBL50M-H	50 m	Long bending life	IP67	
	MR-J3ENSCBL2M-L	2 m	Standard	IP67	
	MR-J3ENSCBL5M-L	5 m	Standard	IP67	
	MR-J3ENSCBL10M-L	10 m	Standard	IP67	
	MR-J3ENSCBL20M-L	20 m	Standard	IP67	
	MR-J3ENSCBL30M-L	30 m	Standard	IP67	For HG-KR/HG-MR (junction type) <sup>(Note 4)</sup> , For HG-SR/HG-JR53(4), 73(4), 103(4), 153(4), 203(4), 353(4), 503(4), 703(4), 903(4)/ HG-RR/HG-UR (direct connection type)
	MR-ENECBL2M-H-MTH	2 m	Long bending life	IP67	
	MR-ENECBL5M-H-MTH	5 m	Long bending life	IP67	
	MR-ENECBL10M-H-MTH	10 m	Long bending life	IP67	
	MR-ENECBL20M-H-MTH	20 m	Long bending life	IP67	
	MR-ENECBL30M-H-MTH	30 m	Long bending life	IP67	
	MR-ENECBL40M-H-MTH	40 m	Long bending life	IP67	
	MR-ENECBL50M-H-MTH	50 m	Long bending life	IP67	
	MR-J3W03ENCBL1M-A-H	1 m	Long bending life	-	For HG-AK
	MR-J3W03ENCBL2M-A-H	2 m	Long bending life	-	
	MR-J3W03ENCBL5M-A-H	5 m	Long bending life	-	
	MR-J3W03ENCBL10M-A-H	10 m	Long bending life	-	
MR-J3W03ENCBL20M-A-H	20 m	Long bending life	-		
MR-J3W03ENCBL30M-A-H	30 m	Long bending life	-		

### Notes:

1. Use this in combination with MR-EKCB\_L-M-H (20 m to 50 m), MR-EKCB\_L-M-L (20 m or 30 m), or MR-ECNM.
2. Use this in combination with MR-J3JCBL03M-A1-L or MR-J3JCBL03M-A2-L.
3. Use this in combination with MR-J3ENSCBL\_M-H, MR-J3ENSCBL\_M-L, or MR-J3SCNS.
4. Use this in combination with MR-J3JSCBL03M-A1-L or MR-J3JSCBL03M-A2-L when using for HG-KR or HG-MR series.

Encoder cables

Item	Model	Length	Bending life	IP rating	Application
Encoder cables	MR-ENE4CBL5M-H-MTH	5 m	Long bending life	IP67	For HG-JR110K24W0C, 150K24W0C, 180K24W0C, 200K24W0C, 220K24W0C
	MR-ENE4CBL10M-H-MTH	10 m	Long bending life	IP67	
	MR-ENE4CBL20M-H-MTH	20 m	Long bending life	IP67	
	MR-ENE4CBL30M-H-MTH	30 m	Long bending life	IP67	
	MR-ENE4CBL40M-H-MTH	40 m	Long bending life	IP67	
Encoder cables between drive units	MR-ENE4CBL50M-H-MTH	50 m	Long bending life	IP67	For MR-J4-DU45KB4-RJ100/ MR-J4-DU55KB4-RJ100
	MR-J4CN2CBL1M-H	1 m	Long bending life	-	
	MR-J4CN2CBL2M-H	2 m	Long bending life	-	
	MR-J4CN2CBL3M-H	3 m	Long bending life	-	
	MR-J4CN2CBL5M-H	5 m	Long bending life	-	

Junction cables

Item	Model	Length	Bending life	IP rating	Application
Junction cable for fully closed loop control	MR-J4FCCBL03M	0.3 m	-	-	For branching load-side encoder
Junction cable for linear servo motor	MR-J4THCBL03M	0.3 m	-	-	For branching thermistor

Encoder connector sets/Junction connector sets

Item	Model	Description	IP rating	Application
Encoder connector set (one-touch connection type)	MR-J3SCNS	Straight type Junction connector or encoder connector × 1, Servo amplifier connector × 1	IP67	For HG-KR/HG-MR (junction type) <sup>(Note 2)</sup> , For HG-SR/HG-JR53(4), 73(4), 103(4), 153(4), 203(4), 353(4), 503(4), 703(4), 903(4)/ HG-RR/HG-UR (direct connection type)
Encoder connector set (screw type)	MR-ENCNS2	Straight type Junction connector or encoder connector × 1, Servo amplifier connector × 1	IP67	For HG-KR/HG-MR (junction type) <sup>(Note 2)</sup> , For HG-SR/HG-JR53(4), 73(4), 103(4), 153(4), 203(4), 353(4), 503(4), 703(4), 903(4)/ HG-RR/HG-UR (direct connection type)
Encoder connector set (one-touch connection type)	MR-J3SCNSA	Angle type Encoder connector × 1, Servo amplifier connector × 1	IP67	For HG-SR/HG-JR53(4), 73(4), 103(4), 153(4), 203(4), 353(4), 503(4), 703(4), 903(4)/ HG-RR/HG-UR
Encoder connector set (screw type)	MR-ENCNS2A	Angle type Encoder connector × 1, Servo amplifier connector × 1	IP67	For HG-SR/HG-JR53(4), 73(4), 103(4), 153(4), 203(4), 353(4), 503(4), 703(4), 903(4)/ HG-RR/HG-UR
Encoder connector set	MR-ECNM	Junction connector × 1, Servo amplifier connector × 1	IP20	For HG-KR/HG-MR (junction type) <sup>(Note 1)</sup> , For connecting load-side encoder or linear encoder
	MR-ENECNS	Straight type Encoder connector × 1, Servo amplifier connector × 1	IP67	For HG-JR601(4), 801(4), 12K1(4), 15K1(4), 20K1(4), 25K1(4), 30K1(4), 37K1(4), 701M(4), 11K1M(4), 15K1M(4), 22K1M(4), 30K1M(4), 37K1M(4), 45K1M4, 55K1M4, 110K24W0C, 150K24W0C, 180K24W0C, 200K24W0C, 220K24W0C
	MR-J3CN2	Servo amplifier connector × 1	-	For connecting load-side encoder, linear encoder, or thermistor
	MR-J3DDCNS	Encoder connector or absolute position storage unit connector × 1, Servo amplifier connector × 1	IP67	For TM-RG2M/TM-RU2M/TM-RFM (connecting direct drive motor and servo amplifier, or absolute position storage unit and servo amplifier)
	MR-J3DDSPS	Encoder connector × 1, Absolute position storage unit connector × 1	IP67	For TM-RG2M/TM-RU2M/TM-RFM (connecting direct drive motor and absolute position storage unit)
	MR-J3W03CN2-2P	Encoder connector × 2, Servo amplifier connector × 2	-	For HG-AK
	MR-J3W03CN2-20P	Encoder connector × 20, Servo amplifier connector × 20	-	For HG-AK
Connector set	MR-J3THMCN2	Junction connector × 2, Servo amplifier connector × 1	-	For branching load-side encoder or thermistor

Notes:

1. Use this in combination with MR-J3JCBL03M-A1-L or MR-J3JCBL03M-A2-L.
2. Use this in combination with MR-J3JSCBL03M-A1-L or MR-J3JSCBL03M-A2-L when using for HG-KR or HG-MR series.

# Product List

## Servo motor power cables

Item	Model	Length	Bending life	IP rating	Application
Servo motor power cable (load-side lead, lead-out)	MR-PWS1CBL2M-A1-H	2 m	Long bending life	IP65	For HG-KR/HG-MR (direct connection type)
	MR-PWS1CBL5M-A1-H	5 m	Long bending life	IP65	For HG-KR/HG-MR (direct connection type)
	MR-PWS1CBL10M-A1-H	10 m	Long bending life	IP65	For HG-KR/HG-MR (direct connection type)
	MR-PWS1CBL2M-A1-L	2 m	Standard	IP65	For HG-KR/HG-MR (direct connection type)
	MR-PWS1CBL5M-A1-L	5 m	Standard	IP65	For HG-KR/HG-MR (direct connection type)
Servo motor power cable (opposite to load-side lead, lead-out)	MR-PWS1CBL2M-A2-H	2 m	Long bending life	IP65	For HG-KR/HG-MR (direct connection type)
	MR-PWS1CBL5M-A2-H	5 m	Long bending life	IP65	For HG-KR/HG-MR (direct connection type)
	MR-PWS1CBL10M-A2-H	10 m	Long bending life	IP65	For HG-KR/HG-MR (direct connection type)
	MR-PWS1CBL2M-A2-L	2 m	Standard	IP65	For HG-KR/HG-MR (direct connection type)
	MR-PWS1CBL5M-A2-L	5 m	Standard	IP65	For HG-KR/HG-MR (direct connection type)
Servo motor power cable (load-side lead, lead-out)	MR-PWS2CBL03M-A1-L	0.3 m	Standard	IP55	For HG-KR/HG-MR (junction type)
Servo motor power cable (opposite to load-side lead, lead-out)	MR-PWS2CBL03M-A2-L	0.3 m	Standard	IP55	For HG-KR/HG-MR (junction type)
Servo motor power cable (For HG-AK series standard servo motors)	MR-J4W03PWCBL1M-H	1 m	Long bending life	-	For HG-AK
	MR-J4W03PWCBL2M-H	2 m	Long bending life	-	For HG-AK
	MR-J4W03PWCBL5M-H	5 m	Long bending life	-	For HG-AK
	MR-J4W03PWCBL10M-H	10 m	Long bending life	-	For HG-AK
	MR-J4W03PWCBL20M-H	20 m	Long bending life	-	For HG-AK
Servo motor power cable (For HG-AK series servo motor with electromagnetic brake)	MR-J4W03PWCBL30M-H	30 m	Long bending life	-	For HG-AK
	MR-J4W03PWBRCL1M-H	1 m	Long bending life	-	For HG-AK
	MR-J4W03PWBRCL2M-H	2 m	Long bending life	-	For HG-AK
	MR-J4W03PWBRCL5M-H	5 m	Long bending life	-	For HG-AK
	MR-J4W03PWBRCL10M-H	10 m	Long bending life	-	For HG-AK
	MR-J4W03PWBRCL20M-H	20 m	Long bending life	-	For HG-AK
	MR-J4W03PWBRCL30M-H	30 m	Long bending life	-	For HG-AK

## Servo motor power connector sets

Item	Model	Description	IP rating	Application
Servo motor power connector set	MR-PWCNF	Straight type Power connector × 1	IP67	For TM-RG2M/TM-RU2M/ TM-RFM_C20, _E20
	MR-PWCNS4	Straight type Power connector × 1	IP67	For HG-SR51, 81, 52(4), 102(4), 152(4)/ HG-JR53(4), 73(4), 103(4), 153(4), 203(4), 3534, 5034/ TM-RFM_G20
	MR-PWCNS5	Straight type Power connector × 1	IP67	For HG-SR121, 201, 301, 202(4), 352(4), 502(4)/HG-JR353, 503/ TM-RFM040J10, 120J10
	MR-PWCNS3	Straight type Power connector × 1	IP67	For HG-SR421, 702(4)/HG-JR703(4), 903(4), 601(4), 801(4), 12K1(4), 701M(4), 11K1M(4), 15K1M(4)/ TM-RFM240J10
	MR-PWCNS1	Straight type Power connector × 1	IP67	For HG-RR103, 153, 203/ HG-UR72, 152
	MR-PWCNS2	Straight type Power connector × 1	IP67	For HG-RR353, 503/ HG-UR202, 352, 502
		MR-J4W03CNP2-2P	Power connector × 2	-
	MR-J4W03CNP2-20P	Power connector × 20	-	For HG-AK

Cooling fan power connector set

Item	Model	Description	IP rating	Application
Cooling fan power connector set	MR-PWCNF	Straight type Power connector × 1	IP67	For HG-JR15K1(4), 20K1(4), 25K1(4), 30K1(4), 37K1(4), 22K1M(4), 30K1M(4), 37K1M(4), 45K1M4, 55K1M4

Electromagnetic brake cables

Item	Model	Length	Bending life	IP rating	Application
Electromagnetic brake cable (load-side lead, lead-out)	MR-BKS1CBL2M-A1-H	2 m	Long bending life	IP65	For HG-KR/HG-MR (direct connection type)
	MR-BKS1CBL5M-A1-H	5 m	Long bending life	IP65	For HG-KR/HG-MR (direct connection type)
	MR-BKS1CBL10M-A1-H	10 m	Long bending life	IP65	For HG-KR/HG-MR (direct connection type)
	MR-BKS1CBL2M-A1-L	2 m	Standard	IP65	For HG-KR/HG-MR (direct connection type)
	MR-BKS1CBL5M-A1-L	5 m	Standard	IP65	For HG-KR/HG-MR (direct connection type)
	MR-BKS1CBL10M-A1-L	10 m	Standard	IP65	For HG-KR/HG-MR (direct connection type)
Electromagnetic brake cable (opposite to load-side lead, lead-out)	MR-BKS1CBL2M-A2-H	2 m	Long bending life	IP65	For HG-KR/HG-MR (direct connection type)
	MR-BKS1CBL5M-A2-H	5 m	Long bending life	IP65	For HG-KR/HG-MR (direct connection type)
	MR-BKS1CBL10M-A2-H	10 m	Long bending life	IP65	For HG-KR/HG-MR (direct connection type)
	MR-BKS1CBL2M-A2-L	2 m	Standard	IP65	For HG-KR/HG-MR (direct connection type)
	MR-BKS1CBL5M-A2-L	5 m	Standard	IP65	For HG-KR/HG-MR (direct connection type)
	MR-BKS1CBL10M-A2-L	10 m	Standard	IP65	For HG-KR/HG-MR (direct connection type)
Electromagnetic brake cable (load-side lead, lead-out)	MR-BKS2CBL03M-A1-L	0.3 m	Standard	IP55	For HG-KR/HG-MR (junction type)
Electromagnetic brake cable (opposite to load-side lead, lead-out)	MR-BKS2CBL03M-A2-L	0.3 m	Standard	IP55	For HG-KR/HG-MR (junction type)

Electromagnetic brake connector sets

Item	Model	Description	IP rating	Application
Electromagnetic brake connector set (one-touch connection type)	MR-BKCNS1	Straight type, Electromagnetic brake connector × 1	IP67	For HG-SR/HG-JR53(4)B, 73(4)B, 103(4)B, 153(4)B, 203(4)B, 353(4)B, 503(4)B, 703(4)B, 903(4)B
Electromagnetic brake connector set (screw type)	MR-BKCNS2	Straight type, Electromagnetic brake connector × 1	IP67	For HG-SR/HG-JR53(4)B, 73(4)B, 103(4)B, 153(4)B, 203(4)B, 353(4)B, 503(4)B, 703(4)B, 903(4)B
Electromagnetic brake connector set (one-touch connection type)	MR-BKCNS1A	Angle type, Electromagnetic brake connector × 1	IP67	For HG-SR/HG-JR53(4)B, 73(4)B, 103(4)B, 153(4)B, 203(4)B, 353(4)B, 503(4)B, 703(4)B, 903(4)B
Electromagnetic brake connector set (screw type)	MR-BKCNS2A	Angle type, Electromagnetic brake connector × 1	IP67	For HG-SR/HG-JR53(4)B, 73(4)B, 103(4)B, 153(4)B, 203(4)B, 353(4)B, 503(4)B, 703(4)B, 903(4)B
Electromagnetic brake connector set	MR-BKCN	Straight type, Electromagnetic brake connector × 1	IP67	For HG-JR601(4)B, 801(4)B, 12K1(4)B, 701M(4)B, 11K1M(4)B, 15K1M(4)B/ HG-UR202B, 352B, 502B

Servo Amplifiers

Rotary Servo Motors

Linear Servo Motors

Direct Drive Motors

Options/Peripheral  
Equipment

LVS/Wires

Product List

Precautions

# Product List

## SSCNET III cables/SSCNET III connector set

Item	Model	Length	Bending life	IP rating	Application <sup>(Note 1)</sup>
SSCNET III cable (standard cord inside cabinet) compatible with SSCNET III(/H)	MR-J3BUS015M	0.15 m	Standard	-	For MR-J4-B_/B_-RJ, MR-J4-DUB_/DUB_-RJ/ DUB4-RJ100, and MR-J4W_-B_
	MR-J3BUS03M	0.3 m	Standard	-	For MR-J4-B_/B_-RJ, MR-J4-DUB_/DUB_-RJ/ DUB4-RJ100, and MR-J4W_-B_
	MR-J3BUS05M	0.5 m	Standard	-	For MR-J4-B_/B_-RJ, MR-J4-DUB_/DUB_-RJ/ DUB4-RJ100, and MR-J4W_-B_
	MR-J3BUS1M	1 m	Standard	-	For MR-J4-B_/B_-RJ, MR-J4-DUB_/DUB_-RJ/ DUB4-RJ100, and MR-J4W_-B_
	MR-J3BUS3M	3 m	Standard	-	For MR-J4-B_/B_-RJ, MR-J4-DUB_/DUB_-RJ/ DUB4-RJ100, and MR-J4W_-B_
SSCNET III cable (standard cable outside cabinet) compatible with SSCNET III(/H)	MR-J3BUS5M-A	5 m	Standard	-	For MR-J4-B_/B_-RJ, MR-J4-DUB_/DUB_-RJ/ DUB4-RJ100, and MR-J4W_-B_
	MR-J3BUS10M-A	10 m	Standard	-	For MR-J4-B_/B_-RJ, MR-J4-DUB_/DUB_-RJ/ DUB4-RJ100, and MR-J4W_-B_
	MR-J3BUS20M-A	20 m	Standard	-	For MR-J4-B_/B_-RJ, MR-J4-DUB_/DUB_-RJ/ DUB4-RJ100, and MR-J4W_-B_
SSCNET III cable (long distance cable) compatible with SSCNET III(/H)	MR-J3BUS30M-B	30 m	Long bending life	-	For MR-J4-B_/B_-RJ, MR-J4-DUB_/DUB_-RJ/ DUB4-RJ100, and MR-J4W_-B_
	MR-J3BUS40M-B	40 m	Long bending life	-	For MR-J4-B_/B_-RJ, MR-J4-DUB_/DUB_-RJ/ DUB4-RJ100, and MR-J4W_-B_
	MR-J3BUS50M-B	50 m	Long bending life	-	For MR-J4-B_/B_-RJ, MR-J4-DUB_/DUB_-RJ/ DUB4-RJ100, and MR-J4W_-B_
SSCNET III connector set compatible with SSCNET III(/H)	MR-J3BCN1	-	-	-	For MR-J4-B_/B_-RJ, MR-J4-DUB_/DUB_-RJ/ DUB4-RJ100, and MR-J4W_-B_

## Bus bar/Adjustment bar

Item	Model	Length	Application
Bus bar	MR-DCBAR137-B52	-	For connecting between power regeneration converter unit and drive unit, and between drive units
	MR-DCBAR159-B52	-	For connecting between power regeneration converter unit and drive unit
	MR-DCBAR170-B52	-	For connecting between drive units
	MR-DCBAR235-B52	-	For connecting between power regeneration converter unit and drive unit, and between drive units
	MR-DCBAR255-B52	-	For connecting between power regeneration converter unit and drive unit
	MR-DCBAR310-B52	-	For connecting between drive units
	MR-DCBAR409-B52	-	For connecting between drive units
	MR-DCBAR159-B53	-	For connecting between power regeneration converter unit and drive unit, and between drive units
	MR-DCBAR257-B53	-	For connecting between power regeneration converter unit and drive unit, and between drive units
	MR-DCBAR082-C02	-	For connecting between drive units
	MR-DCBAR105-C03	-	For connecting between drive units
Adjustment bar <sup>(Note 2)</sup>	MR-DCBAR035-B05	-	-

Notes:

- Note that options/peripheral equipment necessary for servo amplifiers with special specifications are the same as those for standard servo amplifiers. Refer to the servo amplifiers with the same rated output.
- The adjustment bar is required when the total number of MR-J4-DU900B(4)(-RJ) and MR-J4-DU11KB(4)(-RJ) drive units connected to the power regeneration converter unit is even.



## Junction terminal blocks/Junction terminal block cables

Item	Model	Length	Application <sup>(Note 1)</sup>
Junction terminal block (26 pins)	MR-TB26A	-	For MR-J4W_-B_
Junction terminal block cable (for MR-TB26A)	MR-TBNATBL05M	0.5 m	For connecting MR-J4W_-B_ and MR-TB26A
	MR-TBNATBL1M	1 m	For connecting MR-J4W_-B_ and MR-TB26A
Junction terminal block (50 pins)	MR-TB50	-	For MR-J4-A_ / A_-RJ, MR-J4-03A6/ 03A6-RJ, and MR-J4-DUA_ / DUA_-RJ
Junction terminal block cable (for MR-TB50)	MR-J2M-CN1TBL05M	0.5 m	For connecting MR-J4-A_ / A_-RJ, MR-J4-03A6/ 03A6-RJ, MR-J4-DUA_ / DUA_-RJ, MR-D01, and MR-TB50
	MR-J2M-CN1TBL1M	1 m	For connecting MR-J4-A_ / A_-RJ, MR-J4-03A6/ 03A6-RJ, MR-J4-DUA_ / DUA_-RJ, MR-D01, and MR-TB50
Junction terminal block cable (for PS7DW-20V14B-F)	MR-J2HBUS05M	0.5 m	For connecting MR-J4-GF_ / MR-J4-GF_-RJ, MR-J4-B_ / B_-RJ, MR-J4-DUB_ / DUB_-RJ/ DUB4-RJ100, MR-D01, PS7DW-20V14B-F (Toho Technology Corp.)
	MR-J2HBUS1M	1 m	For connecting MR-J4-GF_ / MR-J4-GF_-RJ, MR-J4-B_ / B_-RJ, MR-J4-DUB_ / DUB_-RJ/ DUB4-RJ100, MR-D01, PS7DW-20V14B-F (Toho Technology Corp.)
	MR-J2HBUS5M	5 m	For connecting MR-J4-GF_ / MR-J4-GF_-RJ, MR-J4-B_ / B_-RJ, MR-J4-DUB_ / DUB_-RJ/ DUB4-RJ100, MR-D01, PS7DW-20V14B-F (Toho Technology Corp.)

## Batteries/Battery case/Battery cables

Item	Model	Length	Application <sup>(Note 1)</sup>
Battery	MR-BAT6V1SET	-	For MR-J4-B_ / B_-RJ, MR-J4-A_ / A_-RJ, MR-J4-DUB_ / DUB_-RJ/ DUB4-RJ100, and MR-J4-DUA_ / DUA_-RJ
	MR-BAT6V1SET-A	-	For MR-J4-GF_ / GF_-RJ, MR-J4W2-0303B6, and MR-J4-03A6/ 03A6-RJ
	MR-BAT6V1	-	For MR-BAT6V1SET, MR-BAT6V1SET-A, and MR-BT6VCASE
Battery for junction battery cable	MR-BAT6V1BJ	-	For MR-BT6VCBL03M
Junction battery cable	MR-BT6VCBL03M	0.3 m	For MR-J4-GF_ / GF_-RJ, MR-J4-B_ / B_-RJ, MR-J4-A_ / A_-RJ, MR-J4-DUB_ / DUB_-RJ/ DUB4-RJ100, and MR-J4-DUA_ / DUA_-RJ
Battery case	MR-BT6VCASE	-	For MR-J4-GF_ / GF_-RJ, MR-J4-B_ / B_-RJ, MR-J4-A_ / A_-RJ, MR-J4-DUB_ / DUB_-RJ, MR-J4-DUA_ / DUA_-RJ, and MR-J4W_-B_
Battery cable	MR-BT6V1CBL03M	0.3 m	For MR-BT6VCASE
	MR-BT6V1CBL1M	1 m	For MR-BT6VCASE
Junction battery cable	MR-BT6V2CBL03M	0.3 m	For MR-BT6VCASE
	MR-BT6V2CBL1M	1 m	For MR-BT6VCASE

## Notes:

- Note that options/peripheral equipment necessary for servo amplifiers with special specifications are the same as those for standard servo amplifiers. Refer to the servo amplifiers with the same rated output.

# Product List

## Regenerative options

Item	Model	Permissible regenerative power	Resistance value	Application <sup>(Note 1)</sup>
Regenerative option (200 V/100 V)	MR-RB032	30 W	40 Ω	For MR-J4-10GF/ GF-RJ to 100GF/ GF-RJ, MR-J4-10B(1)/ B(1)-RJ to 100B/ B-RJ, and MR-J4-10A(1)/ A(1)-RJ to 100A/ A-RJ
	MR-RB12	100 W	40 Ω	For MR-J4-20GF/ GF-RJ to 100GF/ GF-RJ, MR-J4-20B(1)/ B(1)-RJ to 100B/ B-RJ, and MR-J4-20A(1)/ A(1)-RJ to 100A/ A-RJ
	MR-RB30	300 W	13 Ω	For MR-J4-200GF/ GF-RJ, MR-J4-200B/ B-RJ, and MR-J4-200A/ A-RJ
	MR-RB3N	300 W	9 Ω	For MR-J4-350GF/ GF-RJ, MR-J4-350B/ B-RJ, MR-J4-350A/ A-RJ, and MR-J4W2-77B, 1010B
	MR-RB31	300 W	6.7 Ω	For MR-J4-500GF/ GF-RJ, 700GF/ GF-RJ, MR-J4-500B/ B-RJ, 700B/ B-RJ, and MR-J4-500A/ A-RJ, 700A/ A-RJ
	MR-RB32	300 W	40 Ω	For MR-J4-70GF/ GF-RJ, 100GF/ GF-RJ, MR-J4-70B/ B-RJ, 100B/ B-RJ, and MR-J4-70A/ A-RJ, 100A/ A-RJ
	MR-RB50	500 W	13 Ω	For MR-J4-200GF/ GF-RJ, MR-J4-200B/ B-RJ, and MR-J4-200A/ A-RJ
	MR-RB5N	500 W	9 Ω	For MR-J4-350GF/ GF-RJ, MR-J4-350B/ B-RJ, and MR-J4-350A/ A-RJ
	MR-RB51	500 W	6.7 Ω	For MR-J4-500GF/ GF-RJ, 700GF/ GF-RJ, MR-J4-500B/ B-RJ, 700B/ B-RJ, and MR-J4-500A/ A-RJ, 700A/ A-RJ
	MR-RB5R	500 (800) W	3.2 Ω	For MR-J4-11KGF/ GF-RJ, MR-J4-11KB/ B-RJ, and MR-J4-11KA/ A-RJ
	MR-RB9F	850 (1300) W	3 Ω	For MR-J4-15KGF/ GF-RJ, MR-J4-15KB/ B-RJ, and MR-J4-15KA/ A-RJ
	MR-RB9T	850 (1300) W	2.5 Ω	For MR-J4-22KGF/ GF-RJ, MR-J4-22KB/ B-RJ, and MR-J4-22KA/ A-RJ
	MR-RB14	100 W	26 Ω	For MR-J4W2-22B, 44B, and MR-J4W3-222B, 444B
	MR-RB34	300 W	26 Ω	For MR-J4W3-222B, 444B
	MR-RB139	1300 W	1.3 Ω	For MR-CR55K
MR-RB137 <sup>(Note 2)</sup>	3900 W	1.3 Ω	For MR-CR55K	

Notes:

- Note that options/peripheral equipment necessary for servo amplifiers with special specifications are the same as those for standard servo amplifiers. Refer to the servo amplifiers with the same rated output.
- Please purchase three units of MR-RB137 for each resistance regeneration converter unit.

## Regenerative options

Item	Model	Permissible regenerative power	Resistance value	Application <sup>(Note 1)</sup>
Regenerative option (400 V)	MR-RB1H-4	100 W	82 Ω	For MR-J4-60GF4/ GF4-RJ, 100GF4/ GF4-RJ, MR-J4-60B4/ B4-RJ, 100B4/ B4-RJ, and MR-J4-60A4/ A4-RJ, 100A4/ A4-RJ
	MR-RB3M-4	300 W	120 Ω	For MR-J4-60GF4/ GF4-RJ, 100GF4/ GF4-RJ, MR-J4-60B4/ B4-RJ, 100B4/ B4-RJ, and MR-J4-60A4/ A4-RJ, 100A4/ A4-RJ
	MR-RB3G-4	300 W	47 Ω	For MR-J4-200GF4/ GF4-RJ, 350GF4/ GF4-RJ, MR-J4-200B4/ B4-RJ, 350B4/ B4-RJ, and MR-J4-200A4/ A4-RJ, 350A4/ A4-RJ
	MR-RB34-4	300 W	26 Ω	For MR-J4-500GF4/ GF4-RJ, MR-J4-500B4/ B4-RJ, and MR-J4-500A4/ A4-RJ
	MR-RB3U-4	300 W	22 Ω	For MR-J4-700GF4/ GF4-RJ, MR-J4-700B4/ B4-RJ, and MR-J4-700A4/ A4-RJ
	MR-RB5G-4	500 W	47 Ω	For MR-J4-200GF4/ GF4-RJ, 350GF4/ GF4-RJ, MR-J4-200B4/ B4-RJ, 350B4/ B4-RJ, and MR-J4-200A4/ A4-RJ, 350A4/ A4-RJ
	MR-RB54-4	500 W	26 Ω	For MR-J4-500GF4/ GF4-RJ, MR-J4-500B4/ B4-RJ, and MR-J4-500A4/ A4-RJ
	MR-RB5U-4	500 W	22 Ω	For MR-J4-700GF4/ GF4-RJ, MR-J4-700B4/ B4-RJ, and MR-J4-700A4/ A4-RJ
	MR-RB5K-4	500 (800) W	10 Ω	For MR-J4-11KGF4/ GF4-RJ, MR-J4-11KB4/ B4-RJ, and MR-J4-11KA4/ A4-RJ
	MR-RB6K-4	850 (1300) W	10 Ω	For MR-J4-15KGF4/ GF4-RJ, 22KGF4/ GF4-RJ, MR-J4-15KB4/ B4-RJ, 22KB4/ B4-RJ, and MR-J4-15KA4/ A4-RJ, 22KA4/ A4-RJ
	MR-RB137-4	1300 W	4 Ω	For MR-CR55K4
MR-RB13V-4 <sup>(Note 2)</sup>	3900 W	4 Ω	For MR-CR55K4	

Notes:

- Note that options/peripheral equipment necessary for servo amplifiers with special specifications are the same as those for standard servo amplifiers. Refer to the servo amplifiers with the same rated output.
- Please purchase three units of MR-RB13V-4 for each resistance regeneration converter unit.

# Product List

## Peripheral units

Item	Model	Application <sup>(Note 1)</sup>
Functional safety unit	MR-D30	For MR-J4-GF_-RJ, MR-J4-B_-RJ, MR-J4-A_-RJ, and MR-DUB_-RJ/ DUB4-RJ100
Safety logic unit	MR-J3-D05	For MR-J4-GF_/GF_-RJ, MR-J4-B_/B_-RJ, MR-J4-A_/A_-RJ, MR-J4-DUB_/DUB_-RJ, MR-J4-DUA_/DUA_-RJ, and MR-J4W_-B
Extension IO unit	MR-D01	For MR-J4-A_-RJ
Absolute position storage unit	MR-BTAS01	For MR-J4-GF_/GF_-RJ, MR-J4-B_/B_-RJ, MR-J4-A_/A_-RJ, and MR-J4W_-B
Parameter unit	MR-PRU03	For MR-J4-A_/A_-RJ and MR-J4-DUA_/DUA_-RJ
Manual pulse generator	MR-HDP01	For MR-J4-A_-RJ and MR-J4-DUA_-RJ
Dynamic brake (200 V)	DBU-7K-R6	For MR-J4-DU900B/ B-RJ
	DBU-11K	For MR-J4-11KGF/ GF-RJ, MR-J4-11KB/ B-RJ, MR-J4-11KA/ A-RJ, MR-J4-DU900B/ B-RJ, DU11KB/ B-RJ
	DBU-15K	For MR-J4-15KGF/ GF-RJ, MR-J4-15KB/ B-RJ, MR-J4-15KA/ A-RJ, MR-J4-DU15KB/ B-RJ
	DBU-22K-R1	For MR-J4-22KGF/ GF-RJ, MR-J4-22KB/ B-RJ, MR-J4-22KA/ A-RJ, MR-J4-DU22KB/ B-RJ
	DBU-37K-R1	For MR-J4-DU30B/ B-RJ, DU37B/ B-RJ, MR-J4-DU30A/ A-RJ, DU37A/ A-RJ
Dynamic brake (400 V)	DBU-7K-4-2R0	For MR-J4-DU900B4/ B4-RJ
	DBU-11K-4	For MR-J4-11KGF4/ GF4-RJ, MR-J4-11KB4/ B4-RJ, MR-J4-11KA4/ A4-RJ, MR-J4-DU900B4/ B4-RJ, DU11KB4/ B4-RJ
	DBU-22K-4	For MR-J4-15KGF4/ GF4-RJ, 22KGF4/ GF4-RJ, MR-J4-15KB4/ B4-RJ, 22KB4/ B4-RJ, MR-J4-15KA4/ A4-RJ, 22KA4/ A4-RJ, MR-J4-DU15KB4/ B4-RJ, DU22KB4/ B4-RJ
	DBU-55K-4-R5	For MR-J4-DU30KB4/ B4-RJ, DU37KB4/ B4-RJ, DU45KB4/ B4-RJ, DU55KB4/ B4-RJ, MR-J4-DU30KA4/ A4-RJ, DU37KA4/ A4-RJ, DU45KA4/ A4-RJ, DU55KA4/ A4-RJ
	DBU-P55K-4-B	MR-J4-DU45KB4-RJ100/ MR-J4-DU55KB4-RJ100
AC reactor	MR-AL-11K	For MR-CV11K
	MR-AL-18K	For MR-CV18K
	MR-AL-30K	For MR-CV30K
	MR-AL-37K	For MR-CV37K
	MR-AL-45K	For MR-CV45K
	MR-AL-55K	For MR-CV55K
	MR-AL-11K4	For MR-CV11K4
	MR-AL-18K4	For MR-CV18K4
	MR-AL-30K4	For MR-CV30K4
	MR-AL-37K4	For MR-CV37K4
	MR-AL-45K4	For MR-CV45K4
	MR-AL-55K4	For MR-CV55K4
	MR-AL-75K4	For MR-CV75K4
MR-AL-55K4-L	For MR-CV55K4 + MR-J4-DU_B4-RJ100	
Power factor improving DC reactor (200 V)	MR-DCL30K	For MR-CR55K + MR-J4-DU30KB(-RJ)/ MR-J4-DU30KA(-RJ)
	MR-DCL37K	For MR-CR55K + MR-J4-DU37KB(-RJ)/ MR-J4-DU37KA(-RJ)
Power factor improving DC reactor (400 V)	MR-DCL30K-4	For MR-CR55K4 + MR-J4-DU30KB4(-RJ)/ MR-J4-DU30KA4(-RJ)
	MR-DCL37K-4	For MR-CR55K4 + MR-J4-DU37KB4(-RJ)/ MR-J4-DU37KA4(-RJ)
	MR-DCL45K-4	For MR-CR55K4 + MR-J4-DU45KB4(-RJ)/ MR-J4-DU45KA4(-RJ)
	MR-DCL55K-4	For MR-CR55K4 + MR-J4-DU55KB4(-RJ)/ MR-J4-DU55KA4(-RJ)
Panel through attachment	MR-J4ACN15K	For MR-J4-11KGF(4)/ GF(4)-RJ, 15KGF(4)/ GF(4)-RJ, MR-J4-11KB(4)/ B(4)-RJ, 15KB(4)/ B(4)-RJ, MR-J4-11KA(4)/ A(4)-RJ, 15KA(4)/ A(4)-RJ
	MR-J3ACN	For MR-J4-22KGF(4)/ GF(4)-RJ, MR-J4-22KB(4)/ B(4)-RJ, MR-J4-22KA(4)/ A(4)-RJ

Notes:

- Note that options/peripheral equipment necessary for servo amplifiers with special specifications are the same as those for standard servo amplifiers. Refer to the servo amplifiers with the same rated output.

## Peripheral cables/Connector sets

Item	Model	Length	Application <sup>(Note 1)</sup>
STO cable	MR-D05UDL3M-B	3 m	For connecting MR-J4-GF_ / GF_-RJ, MR-J4-B_ / B_-RJ, MR-J4-A_ / A_-RJ, MR-J4-DUB_ / DUB_-RJ, MR-J4-DUA_ / DUA_-RJ, or MR-J4W_-B with MR-J3-D05 and other safety control devices
Monitor cable	MR-J3CN6CBL1M	1 m	For analog monitor output of MR-J4-A_ / A_-RJ, and MR-J4-DUA_ / DUA_-RJ
Personal computer communication cable (USB cable)	MR-J3USBCBL3M	3 m	For MR-J4-GF_ / GF_-RJ, MR-J4-B_ / B_-RJ, MR-J4-A_ / A_-RJ, MR-J4-DUB_ / DUB_-RJ, MR-J4-DUA_ / DUA_-RJ, and MR-J4W_-B_
Protection coordination cable	MR-CUL06M	0.6 m	For connecting power regeneration converter unit or resistance regeneration converter unit and drive unit
	MR-J3CDL05M	0.5 m	For connecting resistance regeneration converter unit and drive unit
Connector set	MR-J3CN1	-	For I/O signals of MR-J4-A_ / A_-RJ, MR-J4-03A6/ 03A6-RJ, MR-J4-DUA_ / DUA_-RJ, and MR-D01
	MR-CCN1	-	For I/O signals of MR-J4-GF_ / GF_-RJ, MR-J4-B_ / B_-RJ, MR-J4-DUB_ / DUB_-RJ, and MR-D01
	MR-J2CMP2	-	For MR-J4W_-B_ (Qty: 1 pc)
	MR-ECN1	-	For MR-J4W_-B_ (Qty: 20 pcs)
	MR-J2CN1-A	-	For connecting power regeneration converter unit or resistance regeneration converter unit and drive unit
	MR-CVCN24S	-	For power regeneration converter unit

## Servo engineering software

Item	Model	Application
MELSOFT MR Configurator2 <sup>(Note 2)</sup>	SW1DNC-MRC2-E	Engineering software for AC servo

Notes:

- Note that options/peripheral equipment necessary for servo amplifiers with special specifications are the same as those for standard servo amplifiers. Refer to the servo amplifiers with the same rated output.
- MR Configurator2 can be obtained by either of the following:
  - Purchase MR Configurator2 alone.
  - Purchase GX Works3 or MT Works2: MR Configurator2 is included in GX Works3 and MT Works2 with software version 1.34L or later.

Servo Amplifiers

Rotary Servo Motors

Linear Servo Motors

Direct Drive Motors

Options/Peripheral Equipment

LV/S/Wires

Product List

Precautions

# Precautions

## For your safety

- To use the products given in this catalog properly, be sure to read the "Instruction Manual" and the appended document prior to use.

## Precautions for model selection

- Select a rotary servo motor or a direct drive motor which has the rated torque equal to or higher than the continuous effective torque.
- Select a linear servo motor which has the continuous thrust equal to or higher than the continuous effective load thrust.
- When the linear servo motor is used for vertical axis, it is necessary to have an anti-drop mechanism using springs and counter balances in the machine side.
- When unbalanced torque is generated, such as in a vertical lift machine, keep the unbalanced torque of the machine under 70% of the servo motor rated torque.
- Create operation patterns by considering the settling time ( $t_s$ ) to complete positioning.
- Load to motor inertia ratio or load to mass ratio must be below the recommended ratio. If the ratio is too large, the expected performance may not be achieved, and the dynamic brake may be damaged.

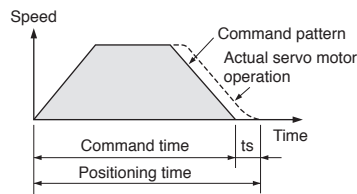

## General safety precautions

### 1. Transportation/Installation

- Combinations of the servo motor and the servo amplifier are predetermined. Confirm the models of the servo motor and the servo amplifier to be used before installation.
- Do not drop or apply strong impact on the servo amplifier and the servo motor as they are precision devices. They may be damaged from such stress or shock.
- When fumigants that contain halogen materials such as fluorine, chlorine, bromine, and iodine are used for disinfecting and protecting wooden packaging from insects, they cause malfunction when entering our products. Please take necessary precautions to ensure that remaining materials from fumigant do not enter our products, or treat packaging with methods other than fumigation (heat method). Additionally, disinfect and protect wood from insects before packing products.
- Do not get on or place heavy objects on the servo amplifier or the servo motor.
- The system must withstand high speeds and high acceleration/ deceleration.
- To enable high-accuracy positioning, ensure the machine rigidity, and keep the machine resonance point at a high level.
- Mount the servo amplifier and the servo motor on nonflammable material. Mounting them directly on or near flammable material may result in fires.
- The regenerative option becomes hot (the temperature rise of 100 °C or higher) with frequent use. Do not install within flammable objects or objects subject to thermal deformation. Make sure that wires do not come into contact with the unit.
- Securely fix the servo motor onto the machine.
- Install electrical and mechanical stoppers at the stroke end.
- Mount the servo amplifier vertically on a wall.
- Do not block intake and exhaust areas of the servo amplifier. Doing so may cause the servo amplifier to malfunction.

- When installing multiple servo amplifiers in a row in a sealed cabinet, leave space around the servo amplifiers as described in Servo Amplifier Instruction Manual. To ensure the life and reliability of the servo amplifiers, prevent heat accumulation by keeping space as open as possible toward the top plate.

### 2. Environment

- Use the servo amplifier and the servo motor in the designated environment.
- Avoid installing the servo amplifier and the servo motor in areas with oil mist or dust. When installing in such areas, be sure to enclose the servo amplifier in a sealed cabinet, and protect the servo motor by furnishing a cover or by taking similar measures.
- Do not use in areas where the servo motor may be constantly subject to cutting fluid or lubricant oil, or where dew could condense because of oil mist, overcooling or excessive humidity. Doing so may deteriorate the insulation of the servo motor.
- To prevent a malfunction or a failure, do not use the servo system products under a strong electric field, magnetic field, or radiation environment.

### 3. Grounding

- Securely ground to prevent electric shocks and to stabilize the potential in the control circuit.
- Connect the grounding wire to the cabinet protective earth (PE) terminal via the servo amplifier for grounding the servo motor.
- The grounding must be connected to prevent faults such as a position mismatch.

### 4. Wiring

- Do not supply power to the output terminals (U, V, and W) of the servo amplifier or the input terminals (U, V, and W) of the servo motor. Doing so damages the servo amplifier and the servo motor.
- Connect the servo motor to the output terminals (U, V, and W) of the servo amplifier.
- Match the phase of the input terminals (U, V, and W) of the servo motor to the output terminals (U, V, and W) of the servo amplifier when connecting them. If they do not match, the servo motor does not operate properly.
- Check the wiring and sequence program thoroughly before switching the power on.
- Carefully select the cable clamping method, and make sure that bending stress and the stress of the cable's own weight are not applied on the cable connection section.
- In an application where the servo motor moves, determine the cable bending radius based on the cable bending life and wire type.

### 5. Initial settings

- For MR-J4-A(-RJ), select a control mode from position, speed or torque with [Pr. PA01]. Position control mode is set as default. Change the parameter setting value when using the other control modes. For MR-J4-GF(-RJ), MR-J4-B(-RJ) or MR-J4W\_-B, the control mode is set by the controller.
- When using the regenerative option, change [Pr. PA02]. The regenerative option is disabled as default.

### 6. Operation

- Do not use a product which is damaged or has missing parts. In that case, replace the product.
- Turn on FLS and RLS (Upper/Lower stroke limit), or LSP and LSN (Forward/Reverse rotation stroke end) in position or speed control mode. The servo motor will not start if the signals are off.
- When a magnetic contactor is installed on the primary side of the servo amplifier, do not perform frequent starts and stops with the magnetic contactor. Doing so may damage the servo amplifier.

- The dynamic brake is a function for emergency stop. Do not use it to stop the servo motor in normal operations.
- As a rough guide, the dynamic brake withstands 1000 times of use when a machine which has load to motor inertia ratio equals to or lower than the recommended ratio stops from the rated speed every 10 minutes.
- When an error occurs, ensure safety by turning the power off, etc., before dealing with the error. Otherwise, it may cause an accident.
- If the protective functions of the servo amplifier activate, turn the power off immediately. Remove the cause before turning the power on again.
- The servo amplifier, the regenerative resistor, and the servo motor can be very hot during or after operation. Take safety measures such as covering them to prevent your hand and/or parts including cables from coming in contact with them.
- Do not touch the servo amplifier, the regenerative resistor, or the servo motor while the power is on or for a while after the power is turned off. Otherwise, an electric shock may occur. Make sure that the charge light is off, and check the voltage between P+ and N- (L+ and L- for the drive unit) with a voltage tester before wiring or inspection.
- In a maintenance inspection, make sure that the emergency stop circuit operates properly such that an operation can be stopped immediately and a power can be shut off by the emergency stop switch.

#### 7. Others

- Do not touch the servo amplifier or the servo motor with wet hands.
- Do not modify the servo amplifier or the servo motor.

### Precautions for Ethernet cables

- Do not apply excessive tension on the Ethernet cable when cabling.
- Refer to relevant Ethernet cable manual to keep the bending radius within the range of specifications.
- Avoid laying the Ethernet cables and the power cables side by side or do not bundle them together. Separate the Ethernet cables from the power cables.

### Precautions for SSCNET III cables

- Do not apply excessive tension on the SSCNET III cable when cabling.
- The minimum bending radius of the SSCNET III cable is 25 mm for MR-J3BUS\_M and 50 mm for MR-J3BUS\_M-A/B. If using these cables under the minimum bending radius, performance cannot be guaranteed.
- If the ends of the SSCNET III cable are dirty, the light will be obstructed, causing malfunctions. Keep the ends clean.
- Do not tighten the SSCNET III cable with cable ties, etc.
- Do not look at the light directly when the SSCNET III cable is not connected.

### Precautions for rotary servo motors and direct drive motors

- Do not hammer the shaft of the rotary servo motor and the rotor of the direct drive motor when installing a pulley or a coupling. Doing so may damage the encoder. When installing the pulley or the coupling to the key shaft servo motor, use the screw hole on the shaft end. Use a pulley extractor when removing the pulley.
- Do not apply a load exceeding the tolerable load onto the rotary servo motor shaft or the direct drive motor rotor. The shaft or the rotor may break.
- When the rotary servo motor is mounted with the shaft vertical (shaft up), take measures on the machine side so that oil from the gear box does not get into the servo motor.
- Mount the geared servo motor in a direction described in "Servo Motor Instruction Manual (Vol. 3)."

- When the direct drive motor is used in a machine such as vertical axis which generates unbalanced torque, be sure to use it in absolute position detection system.
- Do not use the 24 V DC interface power supply for the electromagnetic brake. Provide a dedicated power supply to the electromagnetic brake.
- Do not apply the electromagnetic brake when the servo is on. Doing so may cause the servo amplifier overload or shorten the brake life. Apply the electromagnetic brake when the servo is off.
- Torque may drop due to temperature increase of the rotary servo motor or the direct drive motor. Be sure to use the motor within the specified ambient temperature.
- The temperature rise of the rotary servo motors and the direct drive motors varies depending on the installation environment and the operation conditions. Conduct a test run on the servo motors before an actual operation to make sure that no alarm occurs.

### Precautions for linear encoders

- If the linear encoder is improperly mounted, an alarm or a positioning deviation may occur. Refer to the following general inspections of linear encoder to verify the mounting state. Contact the relevant linear encoder manufacturers for more details.
- General inspections of linear encoder
  - (a) Verify that the gap between the linear encoder head and the linear encoder is appropriate.
  - (b) Check for any rolling or yawing (looseness) on the linear encoder head.
  - (c) Check for contaminations and scratches on the linear encoder head and scale surface.
  - (d) Verify that vibration and temperature are within the specified range.
  - (e) Verify that the speed is within the tolerable range even when overshooting.

## Precautions

### Precautions for linear servo motors

- The linear servo system uses powerful magnets on the secondary side. Magnetic force is inversely proportional to the square of the distance from the magnetic material. Therefore, the magnetic force will be significantly stronger as closer to the magnetic material. Persons installing the linear servo motor as well as operating the machine must be fully cautious. Persons with pacemakers or other medical devices must keep away from the machine.
- Keep cell phones, watches, calculators and other products which may malfunction or fail due to the magnetic force away from the machine. Avoid wearing metals including earrings and necklaces when handling the machine.
- Place a caution sign such as "CAUTION! POWERFUL MAGNET" to give warning against the machine.
- Use non-magnetic tools, when installing or working near the linear servo motor.  
e.g., explosion-proof beryllium copper alloy safety tools (BEALON manufactured by NGK Insulators, Ltd.)
- The permanent magnets on the secondary side generate attraction force, and there is a risk that your hand may be caught. Handle the linear servo motor carefully to avoid serious injury especially when installing the primary side after installing the secondary side.
- If the linear servo motor is used in such an environment where there is magnetic powder, the powder may adhere to the permanent magnets of the secondary side and cause a damage. In that case, take measures to prevent the magnetic powder or pieces from being attracted to the permanent magnets of the secondary side or from going into the gap between primary side and secondary side.
- The linear servo motor is rated IP00. Provide protection measures to prevent dust and oil, etc., as necessary.
- Install the moving part in such manner that the center of gravity of the moving part comes directly above the center of the primary side.
- Lead wires or cables led from the primary side do not have a long bending life. Fix the lead wires or cables to a moving part to prevent the lead wires or cables from repetitive bending.
- Increase in the temperature of the linear servo motor causes a thrust drop. Be sure to use the motor within the specified ambient temperature.

### Disposal of linear servo motors

- Dispose the primary side as industrial waste.
- Demagnetize the secondary side with a heat of 300 °C or higher, and dispose as industrial waste.
- Do not leave the product unattended.

### For safety enhancement

When the MELSERVO-J4 series servo amplifiers, servo motors, options, and peripheral equipment are installed in machines/systems, make sure the machines/systems conform to relevant standards and regulations.

The entire system shall observe the following:

- (1) For safety circuits, use parts and/or devices whose safety are confirmed or which satisfy safety standards.
- (2) For details regarding the use of the servo amplifiers and other cautionary information, refer to relevant Servo Amplifier Instruction Manual.
- (3) Perform risk assessment on the entire machine/system. It is recommended to use a Certification Body for final safety certification.



## Warranty

### 1. Warranty period and coverage

We will repair any failure or defect hereinafter referred to as "failure" in our FA equipment hereinafter referred to as the "Product" arisen during warranty period at no charge due to causes for which we are responsible through the distributor from which you purchased the Product or our service provider. However, we will charge the actual cost of dispatching our engineer for an on-site repair work on request by customer in Japan or overseas countries. We are not responsible for any on-site readjustment and/or trial run that may be required after a defective unit is repaired or replaced.

#### [Term]

For terms of warranty, please contact your original place of purchase.

#### [Limitations]

- (1) You are requested to conduct an initial failure diagnosis by yourself, as a general rule. It can also be carried out by us or our service company upon your request and the actual cost will be charged. However, it will not be charged if we are responsible for the cause of the failure.
- (2) This limited warranty applies only when the condition, method, environment, etc. of use are in compliance with the terms and conditions and instructions that are set forth in the instruction manual and user manual for the Product and the caution label affixed to the Product.
- (3) Even during the term of warranty, the repair cost will be charged on you in the following cases;
  - (i) a failure caused by your improper storing or handling, carelessness or negligence, etc., and a failure caused by your hardware or software problem
  - (ii) a failure caused by any alteration, etc. to the Product made on your side without our approval
  - (iii) a failure which may be regarded as avoidable, if your equipment in which the Product is incorporated is equipped with a safety device required by applicable laws and has any function or structure considered to be indispensable according to a common sense in the industry
  - (iv) a failure which may be regarded as avoidable if consumable parts designated in the instruction manual, etc. are duly maintained and replaced
  - (v) any replacement of consumable parts (battery, fan, smoothing capacitor, etc.)
  - (vi) a failure caused by external factors such as inevitable accidents, including without limitation fire and abnormal fluctuation of voltage, and acts of God, including without limitation earthquake, lightning and natural disasters
  - (vii) a failure generated by an unforeseeable cause with a scientific technology that was not available at the time of the shipment of the Product from our company
  - (viii) any other failures which we are not responsible for or which you acknowledge we are not responsible for

### 2. Term of warranty after the stop of production

- (1) We may accept the repair at charge for another seven (7) years after the production of the product is discontinued. The announcement of the stop of production for each model can be seen in our Sales and Service, etc.
- (2) Please note that the Product (including its spare parts) cannot be ordered after its stop of production.

### 3. Service in overseas countries

Our regional FA Center in overseas countries will accept the repair work of the Product. However, the terms and conditions of the repair work may differ depending on each FA Center. Please ask your local FA Center for details.

### 4. Exclusion of loss in opportunity and secondary loss from warranty liability

Regardless of the gratis warranty term, Mitsubishi shall not be liable for compensation to:

- (1) Damages caused by any cause found not to be the responsibility of Mitsubishi.
- (2) Loss in opportunity, lost profits incurred to the user by Failures of Mitsubishi products.
- (3) Special damages and secondary damages whether foreseeable or not, compensation for accidents, and compensation for damages to products other than Mitsubishi products.
- (4) Replacement by the user, maintenance of on-site equipment, start-up test run and other tasks.

### 5. Change of Product specifications

Specifications listed in our catalogs, manuals or technical documents may be changed without notice.

### 6. Application and use of the Product

- (1) For the use of our General-Purpose AC Servo, its applications should be those that may not result in a serious damage even if any failure or malfunction occurs in General-Purpose AC Servo, and a backup or fail-safe function should operate on an external system to General-Purpose AC Servo when any failure or malfunction occurs.
- (2) Our General-Purpose AC Servo is designed and manufactured as a general purpose product for use at general industries. Therefore, applications substantially influential on the public interest for such as atomic power plants and other power plants of electric power companies, and also which require a special quality assurance system, including applications for railway companies and government or public offices are not recommended, and we assume no responsibility for any failure caused by these applications when used.

In addition, applications which may be substantially influential to human lives or properties for such as airlines, medical treatments, railway service, incineration and fuel systems, man-operated material handling equipment, entertainment machines, safety machines, etc. are not recommended, and we assume no responsibility for any failure caused by these applications when used.

We will review the acceptability of the abovementioned applications, if you agree not to require a specific quality for a specific application. Please contact us for consultation.

- (3) Mitsubishi shall have no responsibility or liability for any problems involving programmable controller trouble and system trouble causes by DoS attacks, unauthorized access, computer viruses, and other cyberattacks.

MEMO

# Extensive global support coverage providing expert help whenever needed

## ■ Global FA centers

### ■ EMEA

#### Europe FA Center

MITSUBISHI ELECTRIC EUROPE B.V. Polish Branch  
Tel: +48-12-347-65-00

#### Germany FA Center

MITSUBISHI ELECTRIC EUROPE B.V. German Branch  
Tel: +49-2102-486-0

#### UK FA Center

MITSUBISHI ELECTRIC EUROPE B.V. UK Branch  
Tel: +44-1707-27-8780

#### Czech Republic FA Center

MITSUBISHI ELECTRIC EUROPE B.V. Czech Branch  
Tel: +420-734-402-587

#### Italy FA Center

MITSUBISHI ELECTRIC EUROPE B.V. Italian Branch  
Tel: +39-039-60531

#### Turkey FA Center

MITSUBISHI ELECTRIC TURKEY Elektrik Urunleri A.S.  
Tel: +90-216-969-2500

### ■ Asia-Pacific

#### China

##### Beijing FA Center

MITSUBISHI ELECTRIC AUTOMATION (CHINA) LTD.  
Beijing FA Center  
Tel: +86-10-6518-8830

##### Guangzhou FA Center

MITSUBISHI ELECTRIC AUTOMATION (CHINA) LTD.  
Guangzhou FA Center  
Tel: +86-20-8923-6730

##### Shanghai FA Center

MITSUBISHI ELECTRIC AUTOMATION (CHINA) LTD.  
Shanghai FA Center  
Tel: +86-21-2322-3030

##### Tianjin FA Center

MITSUBISHI ELECTRIC AUTOMATION (CHINA) LTD.  
Tianjin FA Center  
Tel: +86-22-2813-1015

#### Taiwan

##### Taipei FA Center

SETSUYO ENTERPRISE CO., LTD.  
Tel: +886-2-2299-9917

#### Korea

##### Korea FA Center

MITSUBISHI ELECTRIC AUTOMATION KOREA CO., LTD.  
Tel: +82-2-3660-9630

#### Thailand

##### Thailand FA Center

MITSUBISHI ELECTRIC FACTORY AUTOMATION  
(THAILAND) CO., LTD.  
Tel: +66-2682-6522 to 31

#### ASEAN

##### ASEAN FA Center

MITSUBISHI ELECTRIC ASIA PTE. LTD.  
Tel: +65-6470-2475

#### Malaysia

##### Malaysia FA Center

Malaysia FA Center  
Tel: +60-3-7626-5080

#### Indonesia

##### Indonesia FA Center

PT. MITSUBISHI ELECTRIC INDONESIA  
Cikarang Office  
Tel: +62-21-2961-7797

#### Vietnam

##### Hanoi FA Center

MITSUBISHI ELECTRIC VIETNAM COMPANY LIMITED  
Hanoi Branch Office  
Tel: +84-24-3937-8075

##### Ho Chi Minh FA Center

MITSUBISHI ELECTRIC VIETNAM COMPANY LIMITED  
Tel: +84-28-3910-5945

#### Philippines

##### Philippines FA Center

MELCO Factory Automation Philippines Inc.  
Tel: +63-(0)2-8256-8042

#### India

##### India Ahmedabad FA Center

MITSUBISHI ELECTRIC INDIA PVT. LTD.  
Ahmedabad Branch  
Tel: +91-7965120063

##### India Bangalore FA Center

MITSUBISHI ELECTRIC INDIA PVT. LTD.  
Bangalore Branch  
Tel: +91-80-4020-1600

##### India Chennai FA Center

MITSUBISHI ELECTRIC INDIA PVT. LTD.  
Chennai Branch  
Tel: +91-4445548772

##### India Coimbatore FA Center

MITSUBISHI ELECTRIC INDIA PVT. LTD.  
Coimbatore Branch  
Tel: +91-422-438-5606

##### India Gurgaon FA Center

MITSUBISHI ELECTRIC INDIA PVT. LTD.  
Gurgaon Head Office  
Tel: +91-124-463-0300

##### India Pune FA Center

MITSUBISHI ELECTRIC INDIA PVT. LTD.  
Pune Branch  
Tel: +91-20-2710-2000

### ■ Americas

#### USA

##### North America FA Center

MITSUBISHI ELECTRIC AUTOMATION, INC.  
Tel: +1-847-478-2100

#### Mexico

##### Mexico City FA Center

MITSUBISHI ELECTRIC AUTOMATION, INC.  
Mexico Branch  
Tel: +52-55-3067-7500

##### Mexico FA Center

MITSUBISHI ELECTRIC AUTOMATION, INC.  
Queretaro Office  
Tel: +52-442-153-6014

##### Mexico Monterrey FA Center

MITSUBISHI ELECTRIC AUTOMATION, INC.  
Monterrey Office  
Tel: +52-55-3067-7599

#### Brazil

##### Brazil FA Center

MITSUBISHI ELECTRIC DO BRASIL COMERCIO E  
SERVICOS LTDA.  
Tel: +55-11-4689-3000

## List of Instruction Manuals

Instruction Manuals for MELSERVO-J4 series are listed below:

### Servo Amplifier

Manual name	Manual No.
MR-J4-_A_(-RJ) MR-J4-03A6(-RJ) Servo Amplifier Instruction Manual	SH-030107ENG
MR-J4-_A_-RJ MR-J4-03A6-RJ Servo Amplifier Instruction Manual (Positioning Mode)	SH-030143ENG
MR-J4-_A_-RJ Servo Amplifier Instruction Manual (Modbus-RTU Protocol)	SH-030175
MR-J4-_B_(-RJ) Servo Amplifier Instruction Manual	SH-030106ENG
MR-J4W2-_B_ MR-J4W3-_B_ MR-J4W2-0303B6 Servo Amplifier Instruction Manual	SH-030105ENG
MR-J4-_GF_(-RJ) Servo Amplifier Instruction Manual (Motion Mode)	SH-030218ENG
MR-J4-_GF_(-RJ) Servo Amplifier Instruction Manual (I/O Mode)	SH-030221ENG
MR-J4-_GF_(-RJ) Servo Amplifier Instruction Manual (CC-Link IE Field Network Basic)	SH-030273ENG
MELSERVO-J4 Servo Amplifier Instruction Manual (Troubleshooting)	SH-030109ENG
MR-CV_ MR-CR55K_ MR-J4-DU_ B_(-RJ) MR-J4-DU_ A_(-RJ) Instruction Manual	SH-030153ENG
MR-J4-DU_ B4-RJ100 Drive Unit Instruction Manual	SH-030280ENG

### Servo Motor

Manual name	Manual No.
HG-MR HG-KR HG-SR HG-JR HG-RR HG-UR HG-AK Servo Motor Instruction Manual (Vol. 3)	SH-030113ENG
LM-H3 LM-U2 LM-F LM-K2 Linear Servo Motor Instruction Manual	SH-030110ENG
TM-RFM TM-RG2M TM-RU2M Direct Drive Motor Instruction Manual	SH-030112ENG

### Option

Manual name	Manual No.
Functional safety unit MR-D30 Instruction Manual	SH-030132ENG
Parameter Unit MR-PRU03 Instruction Manual (MR-J4)	SH-030186

### Others

Manual name	Manual No.
EMC Installation Guidelines	IB-67310ENG
Linear Encoder Instruction Manual	SH-030111ENG

Microsoft and Windows are either registered trademarks or trademarks of Microsoft Corporation in the United States and/or other countries.  
 Celeron and Pentium are either registered trademarks or trademarks of Intel Corporation in the United States and/or other countries.  
 PCI Express is US registered trademarks and/or service marks of PCI-SIG.  
 All other company names and product names used in this document are trademarks or registered trademarks of their respective companies.



### Safety Warning

To ensure proper use of the products listed in this catalog, please be sure to read the instruction manual prior to use.

## Creating Solutions Together.



Low-voltage Power Distribution Products



Transformers, Med-voltage Distribution Products



Power Monitoring and Energy Saving Products



Power (UPS) and Environmental Products



Compact and Modular Controllers



Servos, Motors and Inverters



Visualization: HMIs



Edge Computing Products



Numerical Control (NC)



Collaborative and Industrial Robots

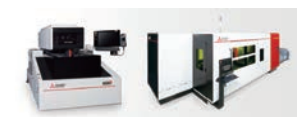

Processing machines: EDM, Lasers



SCADA, analytics and simulation software

Mitsubishi Electric's product lineup, from various controllers and drives to energy-saving devices and processing machines, all help you to automate your world. They are underpinned by software, innovative data monitoring, and modelling systems supported by advanced industrial networking and Edgecross IT/OT connectivity. Together with a worldwide partner ecosystem, Mitsubishi Electric factory automation (FA) has everything to make IoT and Digital Manufacturing a reality.

With a complete portfolio and comprehensive capabilities that combine synergies with diverse business units, Mitsubishi Electric provides a one-stop approach to how companies can tackle the shift to clean energy and energy conservation, carbon neutrality and sustainability, which are now a universal requirement of factories, buildings, and social infrastructure.

We at Mitsubishi Electric FA are your solution partners waiting to work with you as you take a step toward the realization of sustainable manufacturing and society through the application of automation. Let's automate the world together!

# SERVO AMPLIFIERS & MOTORS MELSERVO-J4

Country/Region	Sales office	Tel
USA	Mitsubishi Electric Automation, Inc. 500 Corporate Woods Parkway, Vernon Hills, IL 60061, U.S.A.	Tel : +1-847-478-2100
Mexico	Mitsubishi Electric Automation, Inc. Mexico Branch Boulevard Miguel de Cervantes Saavedra 301, Torre Norte Piso 5, Int. 502, Ampliacion Granada, Miguel Hidalgo, Ciudad de Mexico, Mexico, C.P.11520	Tel : +52-55-3067-7500
Brazil	Mitsubishi Electric do Brasil Comercio e Servicos Ltda. Avenida Adelino Cardana, 293, 21 andar, Bethaville, Barueri SP, Brazil	Tel : +55-11-4689-3000
Germany	Mitsubishi Electric Europe B.V. German Branch Mitsubishi-Electric-Platz 1, 40882 Ratingen, Germany	Tel : +49-2102-486-0
UK	Mitsubishi Electric Europe B.V. UK Branch Travellers Lane, UK-Hatfield, Hertfordshire, AL10 8XB, U.K.	Tel : +44-1707-28-8780
Italy	Mitsubishi Electric Europe B.V. Italian Branch Campus, Energy Park Via Energy Park 14, Vimercate 20871 (MB) Italy	Tel : +39-039-60531
Spain	Mitsubishi Electric Europe B.V. Spanish Branch Carretera de Rubi, 76-80-Appdo. 420, E-08174 Sant Cugat del Valles (Barcelona), Spain	Tel : +34-935-65-3131
France	Mitsubishi Electric Europe B.V. French Branch 2, rue de l'Union-92565 Rueil-Malmaison Cedex-France	Tel : +33-1-55-68-55-68
Czech Republic	Mitsubishi Electric Europe B.V. Czech Branch, Prague Office Pekarska 621/7, 155 00 Praha 5, Czech Republic	Tel : +420-734-402-587
Poland	Mitsubishi Electric Europe B.V. Polish Branch ul. Krakowska 48, 32-083 Balice, Poland	Tel : +48-12-347-65-00
Sweden	Mitsubishi Electric Europe B.V. (Scandinavia) Hedvig Mollersgata 6, 223 55 Lund, Sweden	Tel : +46-8-625-10-00
Turkey	Mitsubishi Electric Turkey Elektrik Urunleri A.S. Serifali Mah. Kale Sok. No:41 Umraniye / Istanbul, Turkey	Tel : +90-216-969-2500
UAE	Mitsubishi Electric Europe B.V. Dubai Branch Dubai Silicon Oasis, P.O.BOX 341241, Dubai, U.A.E.	Tel : +971-4-3724716
South Africa	Adroit Technologies 20 Waterford Office Park, 189 Witkoppen Road, Fourways, South Africa	Tel : +27-11-658-8100
China	Mitsubishi Electric Automation (China) Ltd. Mitsubishi Electric Automation Center, No.1386 Hongqiao Road, Shanghai, China	Tel : +86-21-2322-3030
Taiwan	SETSUYO ENTERPRISE CO., LTD. 5F, No.105, Wugong 3rd Road, Wugu District, New Taipei City 24889, Taiwan	Tel : +886-2-2299-2499
Korea	Mitsubishi Electric Automation Korea Co., Ltd. 7F to 9F, Gangseo Hangang Xi-tower A, 401, Yangcheon-ro, Gangseo-Gu, Seoul, Korea	Tel : +82-2-6103-9474
Singapore	Mitsubishi Electric Asia Pte. Ltd. 307 Alexandra Road, Mitsubishi Electric Building, Singapore 159943	Tel : +65-6473-2486
Thailand	Mitsubishi Electric Factory Automation (Thailand) Co., Ltd. 101, True Digital Park Office, 5th Floor, Sukhumvit Road, Bang Chak, Prakanong, Bangkok, Thailand	Tel : +66-2092-8600
Indonesia	PT. Mitsubishi Electric Indonesia Gedung Jaya 8th Floor, JL. MH. Thamrin No.12, Jakarta Pusat 10340, Indonesia	Tel : +62-21-3192-6461
Vietnam	Mitsubishi Electric Vietnam Company Limited 11th & 12th Floor, Viettel Tower B, 285 Cach Mang Thang Tam Street, Ward 12, District 10, Ho Chi Minh City, Vietnam.	Tel : +84-28-3910-5945
India	Mitsubishi Electric India Pvt. Ltd. Pune Branch ICC-Devi Gaurav Technology Park, Unit no. 402, Fourth Floor, Survey no. 191-192 (P), Opp. Vallabh Nagar Bus Depot, Pune - 411018, Maharashtra, India	Tel : +91-20-4624-2100
Australia	Mitsubishi Electric Australia Pty. Ltd. 348 Victoria Road, P.O. Box 11, Rydalmere, N.S.W 2116, Australia	Tel : +61-2-9684-7777



Mitsubishi Electric's e-F@ctory concept utilizes both FA and IT technologies, to reduce the total cost of development, production and maintenance, with the aim of achieving manufacturing that is a "step ahead of the times". It is supported by the e-F@ctory Alliance Partners covering software, devices, and system integration, creating the optimal e-F@ctory architecture to meet the end users needs and investment plans.



## MITSUBISHI ELECTRIC CORPORATION

HEAD OFFICE: TOKYO BLDG., 2-7-3, MARUNOUCHI, CHIYODA-KU, TOKYO 100-8310, JAPAN  
NAGOYA WORKS: 1-14, YADA-MINAMI 5-CHOME, HIGASHI-KU, NAGOYA 461-8670, JAPAN