



INVERTER

Plug-in option

FR-A8NC E KIT

INSTRUCTION MANUAL

CC-Link communication function

PRE-OPERATION INSTRUCTIONS	1
INSTALLATION	2
WIRING	3
INVERTER SETTING	4
FUNCTION OVERVIEW	5
I/O SIGNAL LIST	6
DETAILS OF INPUT AND OUTPUT SIGNALS	7
PROGRAMMING EXAMPLES	8
HOW TO CHECK FOR ERROR USING THE LEDS	9

Safety instructions

Thank you for choosing this Mitsubishi Electric inverter plug-in option.

This Instruction Manual provides handling information and precautions for use of this product. Incorrect handling might cause an unexpected fault. Before using this product, read all relevant instruction manuals carefully to ensure proper use.

Please forward this Instruction Manual to the end user.

Do not attempt to install, operate, maintain or inspect this product until you have read this Instruction Manual and supplementary documents carefully. Do not use this product until you have a full knowledge of this product mechanism, safety information and instructions. In this Instruction Manual, the safety instruction levels are classified into "WARNING" and "CAUTION".

 **WARNING** Incorrect handling may cause hazardous conditions, resulting in death or severe injury.

 **CAUTION** Incorrect handling may cause hazardous conditions, resulting in medium or slight injury, or may cause only material damage.

Note that even the  **CAUTION** level may lead to a serious consequence depending on conditions. Be sure to follow the instructions of both levels as they are critical to personnel safety.

◆ Electric shock prevention

WARNING

- Do not remove the front cover or the wiring cover while the power of the inverter is ON, and do not run the inverter with the front cover or the wiring cover removed. Otherwise you may access the exposed high voltage terminals or the charging part of the circuitry and get an electric shock.
- Even if power is OFF, do not remove the front cover of the inverter except for wiring or periodic inspection as you may accidentally touch the charged circuits and get an electric shock.
- Before wiring or inspection, check that the display of the inverter operation panel is OFF. Any person who is involved in wiring or inspection shall wait for 10 minutes or longer after power OFF and check that there are no residual voltage using a tester or the like. The capacitor is charged with high voltage for some time after power OFF, and it is dangerous.
- Any person who is involved in wiring or inspection of this product shall be fully competent to do the work.
- This product must be installed before wiring. Otherwise you may get an electric shock or be injured.
- Do not touch this product or handle the cables with wet hands. Doing so may cause an electric shock.
- Do not subject the cables to scratches, excessive stress, heavy loads or pinching. Doing so may cause an electric shock.

◆ Injury prevention

CAUTION

- The voltage applied to each terminal must be as specified in the Instruction Manual. Otherwise an explosion or damage may occur.
- The cables must be connected to the correct terminals. Otherwise an explosion or damage may occur.
- The polarity (+ and -) must be correct. Otherwise an explosion or damage may occur.
- While power is ON or for some time after power OFF, do not touch the inverter as it will be extremely hot. Doing so may cause burns.

◆ Additional instructions

The following instructions must be also followed. If this product is handled incorrectly, it may cause unexpected fault, an injury, or an electric shock.

CAUTION

Transportation and installation

- Do not install or operate this product if it is damaged or has parts missing.
- Do not stand or place heavy objects on this product.
- Ensure the mounting orientation of this product is correct.
- Foreign conductive objects must be prevented from entering the inverter. That includes screws and metal fragments or other flammable substance such as oil.
- If halogens (including fluorine, chlorine, bromine, and iodine) contained in fumigants for wood packages enter this product, the product may be damaged. Prevent the entry of fumigant residuals or use an alternative method such as heat disinfection. Note that sterilization or disinfection of wood packages should be performed before packing the product.

Test operation

- Before starting operation, confirm or adjust the parameter settings. Failure to do so may cause some machines to make unexpected motions.

WARNING

Usage

- Do not modify this product.
- Do not remove any part which is not instructed to be removed in the Instruction Manuals. Doing so may lead to a failure or damage of this product.

CAUTION

Usage

- As all parameters return to their initial values after Parameter clear or All parameter clear is performed, the needed parameters for operation of the inverter and this product must be set again before the operation is started.
- To avoid damage to this product due to static electricity, static electricity in your body must be discharged before you touch this product.
- To maintain the security (confidentiality, integrity, and availability) of the inverter and the system against unauthorized access, DoS*1 attacks, computer viruses, and other cyberattacks from external devices via network, take appropriate measures such as firewalls, virtual private networks (VPNs), and antivirus solutions. We shall have no responsibility or liability for any problems involving inverter trouble and system trouble by DoS attacks, unauthorized access, computer viruses, and other cyberattacks.

Maintenance, inspection and parts replacement

- Do not carry out a megger (insulation resistance) test.

Disposal

- This product must be treated as industrial waste.

*1 DoS: A denial-of-service (DoS) attack disrupts services by overloading systems or exploiting vulnerabilities, resulting in a denial-of-service (DoS) state. product must be treated as industrial waste.

General instruction

- For clarity, illustrations in this Instruction Manual may be drawn with covers or safety guards removed. Ensure all covers and safety guards are properly installed prior to starting operation.
-

— CONTENTS —

Safety instructions	1
<hr/>	
1 PRE-OPERATION INSTRUCTIONS	8
<hr/>	
1.1 Unpacking and product confirmation.....	8
1.2 Component names	9
1.3 Inverter option specifications.....	10
1.4 CC-Link version	11
1.4.1 CC-Link Ver. 1.10	11
1.4.2 CC-Link Ver. 2	12
2 INSTALLATION	13
<hr/>	
2.1 Pre-installation instructions	13
2.2 Installation procedure	13
2.3 Setting of the terminating resistor selection switch	21
3 WIRING	22
<hr/>	
3.1 Connecting the CC-Link dedicated cable.....	22
3.1.1 Fabricating the connection cable	22
3.1.2 Connection to the connector	27
3.1.3 Unit replacement while online	28
3.2 System configuration example.....	30
3.3 Connection of several inverters	31
4 INVERTER SETTING	33
<hr/>	
4.1 Parameter list.....	33
4.2 Operation mode setting	35



4.2.1	Operation mode switching and communication startup mode (Pr.79, Pr.340).....	35
4.3	Operation at communication error occurrence	38
4.3.1	Operation selection at communication error occurrence (Pr.500 to Pr.502, Pr.779)	38
4.3.2	Fault and measures	43
4.4	Inverter reset	44
4.5	CC-Link function setting	46
4.5.1	Station number setting (Pr.542)	46
4.5.2	Baud rate setting (Pr.543)	48
4.5.3	Frequency command with sign (Pr.541)	48
5	FUNCTION OVERVIEW	50
5.1	Function block diagram	50
5.2	Output from the inverter to the network	51
5.3	Input to the inverter from the network	52
6	I/O SIGNAL LIST	53
6.1	CC-Link extended setting (Pr.544)	53
6.2	I/O signal list	54
6.2.1	I/O signal when CC-Link Ver.1 one station (FR-A5NC compatible) is occupied (Pr.544 = 0).....	54
6.2.2	I/O signal when CC-Link Ver.1 one station is occupied (Pr.544 = 1)	57
6.2.3	I/O signal when CC-Link Ver.2 double setting is selected (Pr.544 = 12)	58
6.2.4	I/O signal when CC-Link Ver.2 quadruple setting is selected (Pr.544 = 14)	59
6.2.5	I/O signal when CC-Link Ver.2 octuple setting is selected (Pr.544 = 18)	60
7	DETAILS OF INPUT AND OUTPUT SIGNALS	62
7.1	Details of remote input and output signals	62
7.1.1	Output signals (master module to inverter (FR-A8NC)).....	62
7.1.2	Input signals (inverter (FR-A8NC) to master module).....	65
7.2	Details of remote register	67
7.2.1	Remote register (master module to inverter (FR-A8NC))	67

7.2.2	Remote register (inverter (FR-A8NC) to master module)	70
7.2.3	Instruction codes	74
7.2.4	Monitor codes	78
7.3	Torque command / torque limit by CC-Link communication	79
8	PROGRAMMING EXAMPLES	82
8.1	Program example for reading the inverter status.....	85
8.2	Program example for setting the operation mode.....	86
8.3	Program example for setting the operation commands	87
8.4	Program example for monitoring the output frequency	88
8.5	Program example for parameter reading	89
8.6	Program example for parameter writing.....	90
8.7	Program example for setting the running frequency	91
8.8	Program example for fault record reading	93
8.9	Program example for resetting the inverter at inverter error	94
8.10	Instructions	95
9	HOW TO CHECK FOR ERROR USING THE LEDS	97
9.1	When one inverter is connected	97
9.2	When two or more inverters are connected.....	99
9.3	Communication stops during operation	101
APPENDIX	103
Appendix 1	Instructions for compliance with the EU Directives	103
Appendix 2	Instructions for EAC	104
Appendix 3	Restricted Use of Hazardous Substances in Electronic and Electrical Products	105
Appendix 4	Referenced Standard (Requirement of Chinese standardized law)	106
Appendix 5	Compliance with the UK certification scheme	107







1 PRE-OPERATION INSTRUCTIONS

1.1 Unpacking and product confirmation

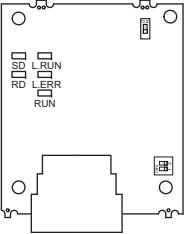
Take the plug-in option out of the package, check the product name, and confirm that the product is as you ordered and intact. This product is a plug-in option made for the FR-E800 series inverters.

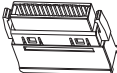
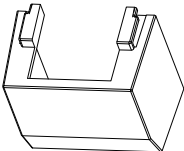
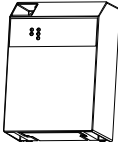
◆ Product confirmation

Check the enclosed items.

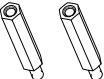
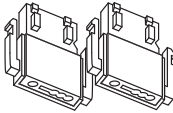
<p>Plug-in option: 1</p> 	<p>Mounting screw (M3 × 8 mm): 2 (Refer to page 14, 16.)</p> 	<p>Junction connector: 1 (Refer to page 14, 16.)</p> 	<p>Option small cover: 1 (Refer to page 16)</p> 	<p>Front cover for plug-in option (with lenses): 1 (Refer to page 14, 16.)</p> 
<p>Recessed neck screw (M3 × 7 mm): 1 (Refer to page 14, 16.)</p> 	<p>Straight spacer: 1 (Refer to page 14, 16.)</p> 	<p>L-shaped spacer: 1 (Refer to page 14, 16.)</p> 	<p>Hexagon spacer: 2 (Refer to page 14, 16.)</p> 	<p>CC-Link communication one-touch connector plug: 2 (Refer to page 24)</p> 

1.2 Component names

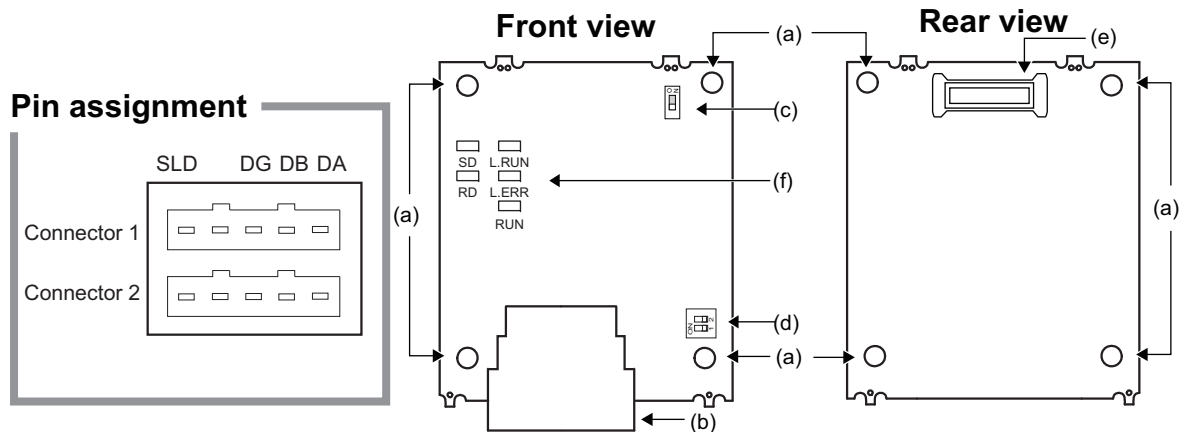

Symbol	Name	Description	Refer to page
a	Mounting hole	Used to fix this product to the inverter by inserting a mounting screw or a spacer.	13
b	CC-Link communication connector	CC-Link communication can be performed with the CC-Link communication connector.	27
c	Switch for manufacturer setting	Switch for manufacturer setting. Do not change the switch setting from the initial setting (OFF )	-
d	Terminating resistor selection switch	Select the resistor value of the terminating resistor.	21
e	Connector	Connected to the junction connector, which is connected to the option connector on the inverter.	13
f	LED (operation status indicator)	Stays ON or blinks to indicate the operating status.	10

◆ Operation status indication LED

Item	Description
L.RUN	Lit when refresh data is properly received. Turns off when a data transmission is stopped for a certain period of time.
L.ERR	<ul style="list-style-type: none">• Lit when a communication error occurs in the own station.• Blinks when the Pr.542 or Pr.543 setting is changed. When power is switched on again or the RES signal is turned on, the setting value is reflected and the LED turns off. (Refer to page 46, 48.)
RUN	Lit during normal operation (5V is supplied in the board) (Lit even in the non-communication status.) Blinks when the master station is CC-Link Ver.1 and the FR-A8NC is CC-Link Ver.2 compatible. (Refer to page 11.)
SD	Turns off when no data is transmitted.
RD	Lit when the received data carrier is detected.

NOTE

- Set the station number using **Pr.542 Communication station number (CC-Link)**. (Refer to [page 46.](#))
- Set transmission baud rate using **Pr.543 Baud rate selection (CC-Link)**. (Refer to [page 48.](#))

1.3 Inverter option specifications

Item	Description
Type	Inverter plug-in option type, one-touch connector connection, online connector (T type (2 to 1)) supported
Power supply	Supplied from the inverter
Number of units connected	42 units max. (Refer to page 53 for the number of stations occupied), May be used with other equipment.
Station type	Remote device station
Number of stations occupied	CC-Link Ver.1: occupies one station, CC-Link Ver.2: occupies one station (selectable from among double, quadruple and octuple)
Communication cable	CC-Link dedicated cable, CC-Link Ver. 1.10 compatible CC-Link dedicated cable

1.4 CC-Link version

1.4.1 CC-Link Ver. 1.10

The conventional CC-Link products, whose inter-station cable lengths have equally been changed to 20 cm or more to improve the inter-station cable length restriction, are defined as CC-Link Ver. 1.10. In comparison, the conventional products are defined as CC-Link Ver. 1.00.

Refer to the CC-Link Master Module Manual for the maximum overall cable lengths and inter-station cable lengths of CC-Link Ver. 1.00 and Ver. 1.10.

CC-Link Ver. 1.10 compatibility conditions

- All modules that comprise a CC-Link system should be compatible with CC-Link Ver. 1.10.
- All data link cables should be CC-Link Ver. 1.10 compatible, CC-Link dedicated cables.

(CC-Link Ver. 1.10 compatible cables have a *CC-Link* logo or Ver. 1.10 indication.)

NOTE

- In a system that uses the CC-Link Ver. 1.00 and Ver. 1.10 modules and cables together, the maximum overall cable length and inter-station cable length are as specified for CC-Link Ver. 1.00.
-

1.4.2 CC-Link Ver. 2

The FR-A8NC is compatible with CC-Link Ver.2. When using the CC-Link Ver.2 setting with the FR-A8NC, the master station needs to be compatible with the CC-Link Ver.2. For CC-Link Ver.2, double, quadruple and octuple settings can be used to increase the remote register (RWr/w) points.

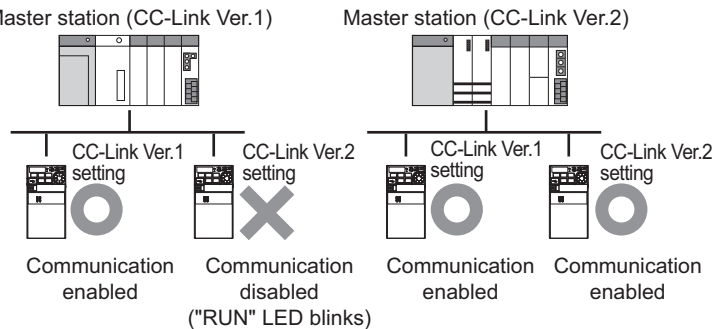

2 INSTALLATION

2.1 Pre-installation instructions

Check that the inverter's input power and the control circuit power are both OFF.

CAUTION

- Do not install or remove this product while the inverter power is ON. Doing so may damage the inverter or this product.
 - To avoid damage due to static electricity, static electricity in your body must be discharged before you touch this product.
-

2.2 Installation procedure

◆ Installing the option

The FR-E800 series inverter has only one plug-in option connector.

NOTE

- Ensure the control circuit terminals are wired before installing the plug-in option. They cannot be wired after the plug-in option is installed.
 - When installing the plug-in option, prevent cables being caught between parts. Otherwise the inverter and the option may be damaged.
-

■ For the FR-E820-0175 (3.7K) or lower, FR-E840-0170 (7.5K) or lower, and FR-E860-0120 (7.5K) or lower

1. Remove the inverter front cover. (Refer to the FR-E800 Instruction Manual (Connection) for instructions to remove the cover.)
2. Use a nipper or the like to cut off the bottom of the front cover for plug-in option.

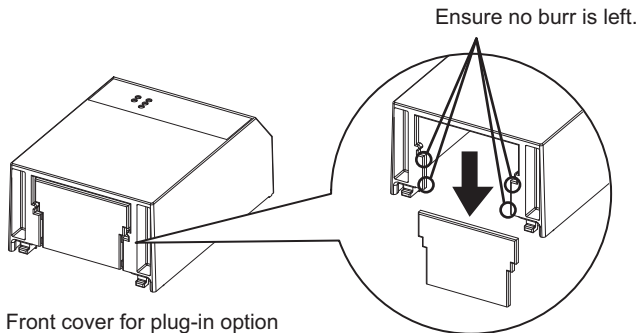

2. Front cover for plug-in option
3. Fit the L-shaped spacer, straight spacer, and junction connector to the plug-in option as shown in the figure on the [page 15](#). Fit the junction connector to the guide of the connector of the plug-in option, and insert the junction connector as far as it goes. Fit the L-shaped spacer to the plug-in option so that the lower edge of the option placed on the ridge of the spacer.

4. Remove the body screws of the inverter, then install the hexagon spacers to the inverter (tightening torque 0.56 to 0.75 N·m).
5. Fit the junction connector, which has been connected to the plug-in option, to the guide of the option connector on the inverter, and insert the junction connector as far as it goes.
6. Fasten this product to the inverter using the two mounting screws through the holes at the upper left and lower right (tightening torque 0.33 to 0.40 N·m). If the connector is not inserted deep enough, the screws cannot be tightened properly. Check the connector.
7. Connect cables to the CC-Link communication connector of the plug-in option (refer to [page 22](#)).
8. After wiring of the plug-in option has been completed, mount the front cover for the plug-in option to the inverter.

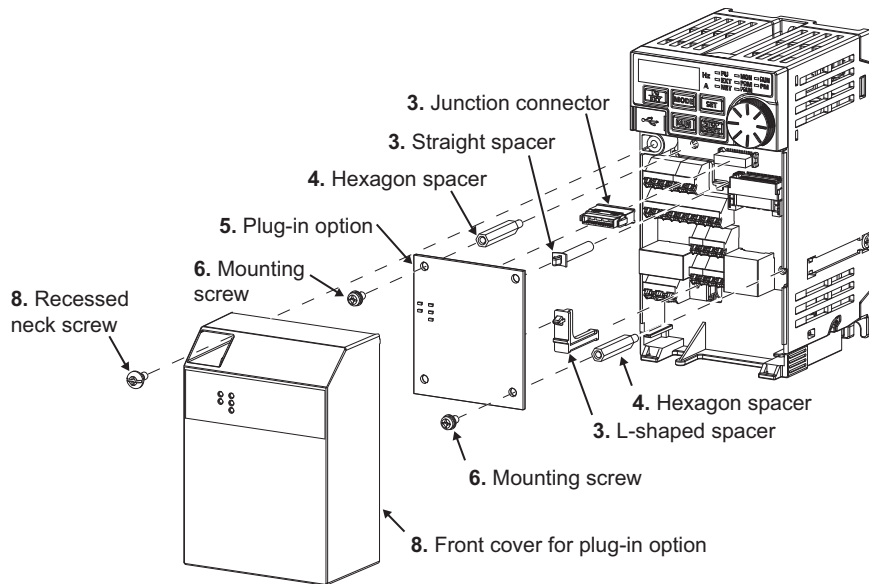

■ For the FR-E820-0240(5.5K) or higher and FR-E840-0230(11K) or higher

1. Remove the upper front cover and the lower front cover from the inverter. (Refer to the FR-E800 Instruction Manual (Connection) for instructions to remove the covers.)
2. Use a nipper or the like to cut off the dummy cover of the lower front cover in order to install the option small cover.

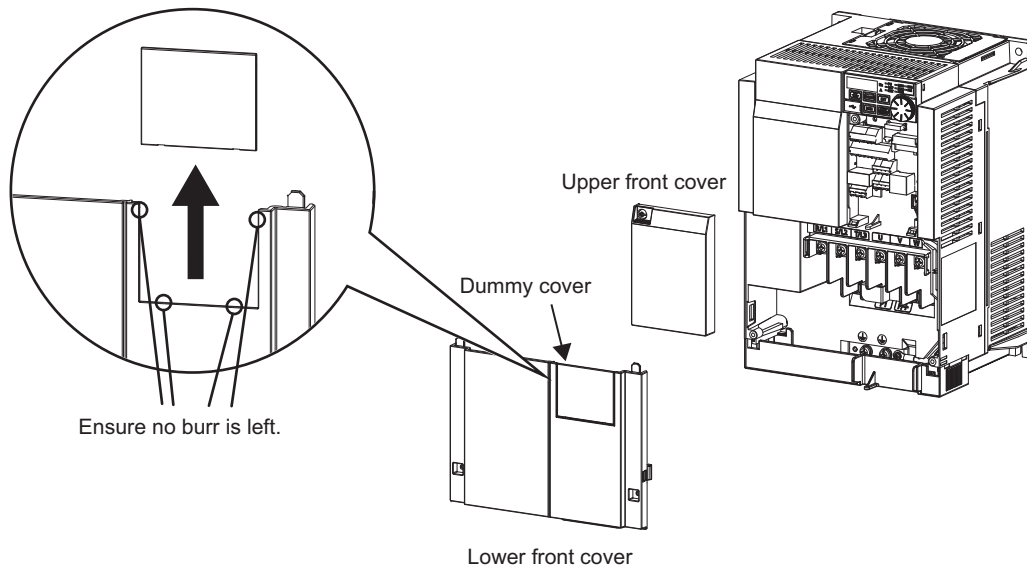

3. Use a nipper or the like to cut off the bottom of the front cover for plug-in option. (For details, refer to [page 14](#).)
4. Fit the L-shaped spacer, straight spacer, and junction connector to the plug-in option as shown in the figure on the [page 18](#). Fit the junction connector to the guide of the connector of the plug-in option, and insert the junction connector as far as it goes. Fit the L-shaped spacer to the plug-in option so that the lower edge of the option placed on the ridge of the spacer.

5. Remove the body screws of the inverter, then install the hexagon spacers to the inverter (tightening torque 0.56 to 0.75 N·m).
6. Fit the junction connector, which has been connected to the plug-in option, to the guide of the option connector on the inverter, and insert the junction connector as far as it goes.
7. Fasten this product to the inverter using the two mounting screws through the holes at the upper left and lower right (tightening torque 0.33 to 0.40 N·m). If the connector is not inserted deep enough, the screws cannot be tightened properly. Check the connector.
8. Connect cables to the CC-Link communication connector of the plug-in option (refer to [page 22](#)).
9. After wiring of the plug-in option has been completed, mount the front cover for the plug-in option to the inverter.
10. Install the option small cover to the front cover for plug-in option by inserting the small cover into the front cover and slide it toward the rear of the inverter.

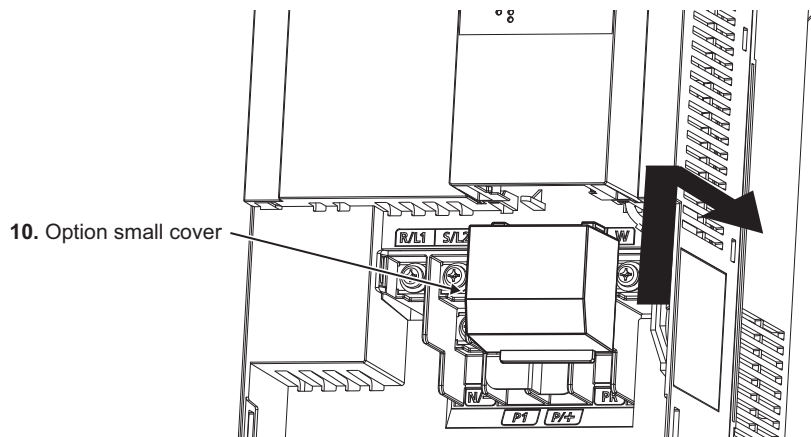

11. Install the lower front cover to the inverter.

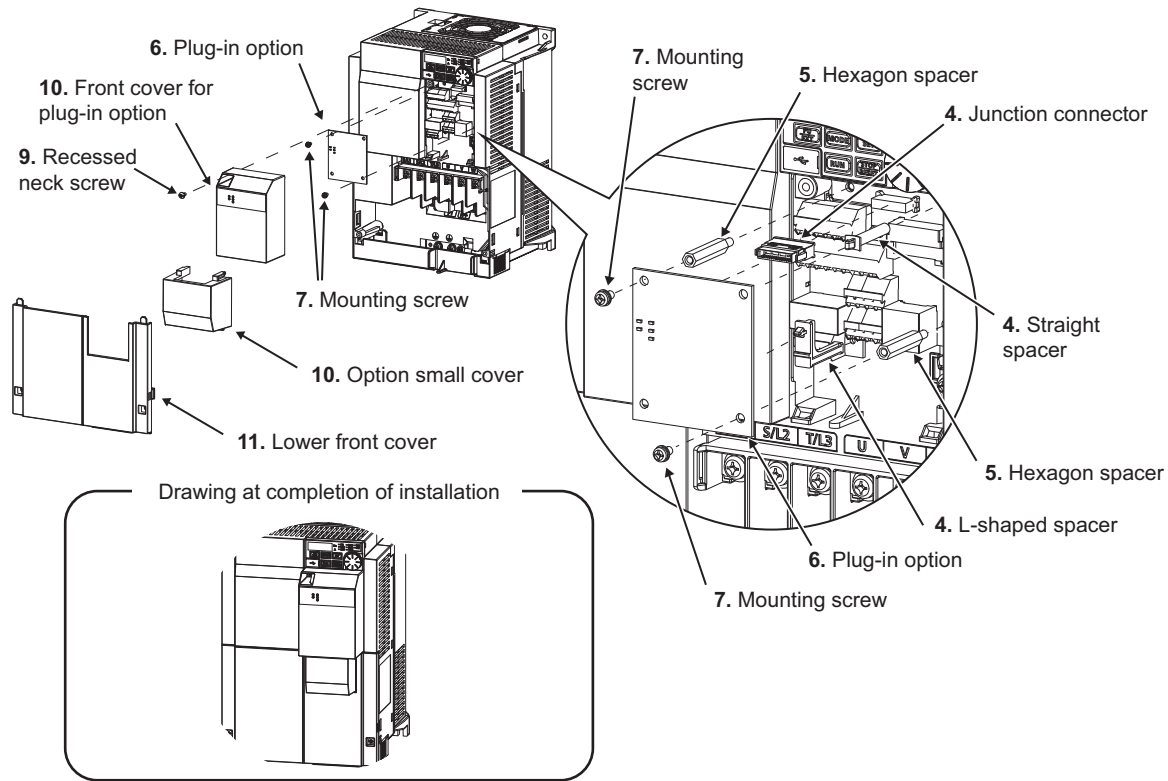

◆ Insertion positions for screws and spacers

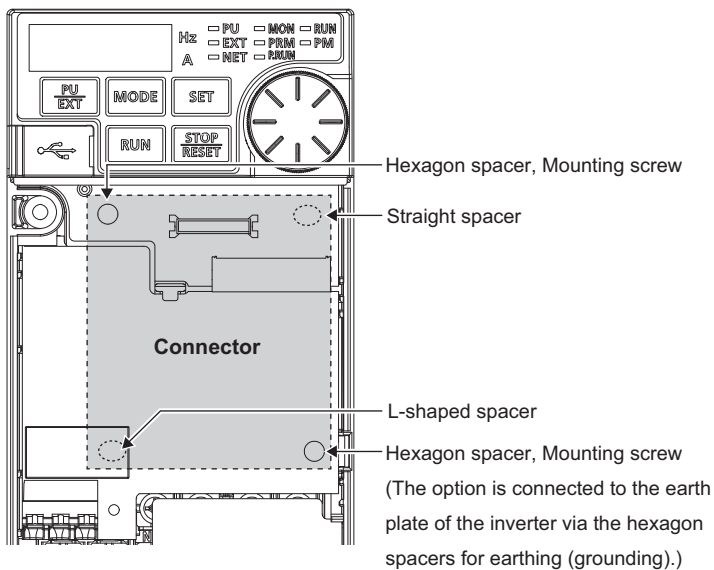

NOTE

- When the junction connector is installed to the plug-in option, the option is fixed with the hooks of the connector. The junction connector cannot be removed from the plug-in option.
- When removing the front cover for plug-in option from the inverter, note that the recessed neck screw cannot be removed from the front cover for plug-in option.
- When the body screws of the inverter are removed to install the hexagon spacers (in Step 4 on [page 15](#) or Step 5 on [page 17](#)), make sure that the control circuit board does not fall off due to the weight of cables.
- Be careful not to drop mounting screws during the installation or removal of the plug-in option.
- When the inverter cannot recognize the option due to improper installation or any other reason, the protective function (E.1) is activated and the inverter cannot be operated.

Mounted position	Fault indication
Option connector	E. 1





- When removing the plug-in option, remove the two screws at the upper left and lower right, and then pull it straight out. Pressure applied to the option connector and to the option board may break the option.

2.3 Setting of the terminating resistor selection switch

Always set the terminating resistor selection switch (refer to [page 9](#)) or connect the one-touch connector plug with terminating resistor (refer to [page 28](#)) to the inverter that is the end station (FR-A8NC) in advance.

The following table lists the specifications of the terminating resistor selection switch.

(In the initial setting, no terminating resistor is set (1: OFF and 2: OFF).)

Setting	1	2	Description
	OFF	OFF	Without terminating resistor (initial setting)
	ON	OFF	Do not use.
	OFF	ON	130 Ω (resistance value with the CC-Link Ver. 1.00 dedicated high performance cable)
	ON	ON	110 Ω

3 WIRING

3.1 Connecting the CC-Link dedicated cable

3.1.1 Fabricating the connection cable

In the CC-Link system, use CC-Link dedicated cables. If the cable used is other than the CC-Link dedicated cable, the performance of the CC-Link system is not guaranteed. Refer to the following list for CC-Link dedicated cables that can be used with one-touch connector plugs.

- CC-Link dedicated cable (as of October 2018) (The product may be changed without notice.)

Model	Manufacturer
FANC-110SBH	Kuramo Electric Co., Ltd.
CS-110	Dyden Corporation
FA-CBL200PSBH	Mitsubishi Electric Engineering Co., Ltd.

NOTE

- For the specifications of the CC-Link dedicated cable, refer to the website of the CC-Link Partner Association. (Website of the CC-Link Partner Association <http://www.cc-link.org/>)

1. Cable-end treatment

Apply the following treatment at wire end of the CC-Link dedicated cable that is inserted to a CC-Link communication one-touch connector plug (accessory).

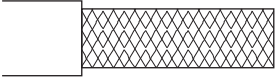
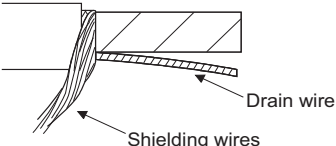
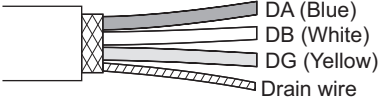
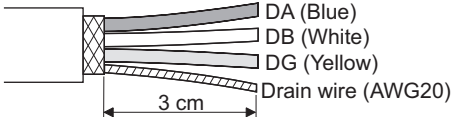
<p>1. Cut the sheath.</p> 	<p>2. Separate shielding wires from the drain wire. Cut the shielding wires.</p> 
<p>3. Cut the aluminum tape and braid.</p>  <p>DA (Blue) DB (White) DG (Yellow) Drain wire</p>	<p>4. Straighten the drain wire and twist it from the root. (Twist seven times or more per 3 cm.)</p>  <p>DA (Blue) DB (White) DG (Yellow) Drain wire (AWG20) 3 cm</p>

NOTE

- Where possible, round the cable tip that is cut off with a tool such as nippers. If the cable is not rounded, it may get caught in the middle of a plug, without fully entering into the plug.
- If required, apply an insulation treatment to the shielding wire area where it is not covered by the CC-Link communication one-touch connector plug.

2. Plug cover check

Check that the plug cover is snapped into the CC-Link communication one-touch connector plug.

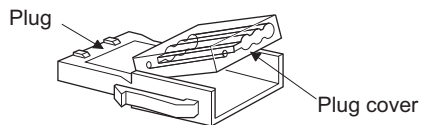

NOTE

- Do not push the plug cover onto the plug before inserting a cable. Once crimped, the plug cover cannot be reused.
- CC-Link communication one-touch connector plug (as of October 2018) (The product may be changed without notice.)

If purchasing a CC-Link communication one-touch connector plug separately, refer to the plugs in the following list.

Model	Manufacturer
A6CON-L5P	Mitsubishi Electric Corporation
35505-6000-B0M GF	3M Japan Limited

3. Cable insertion

Lift up the back of the plug cover, and insert the cable until it reaches the end. Insert each signal cable into the CC-Link communication one-touch connector plug as shown in the following figure.

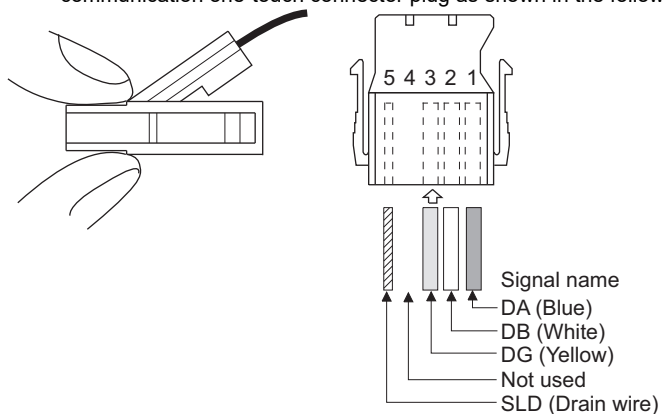

NOTE

- Insert the cable fully. Failure to do so may cause a crimping failure.
- A cable sometimes comes out of the head of the cover. In that case, pull the cable a little so that the cable stays under the plug cover.

4. Crimping the plug cover

Push the plug cover onto the plug with a tool such as pliers. After crimping, check that the plug cover is securely snapped into the plug as shown in the following figure.

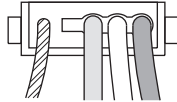

NOTE

- Misaligned latches between the plug cover and the plug may keep the cover lifted. The plug cover is not sufficiently crimped in this condition. Push the plug cover until it snaps into the plug.

3.1.2 Connection to the connector

Connect the CC-Link dedicated cable to the CC-Link communication connector.

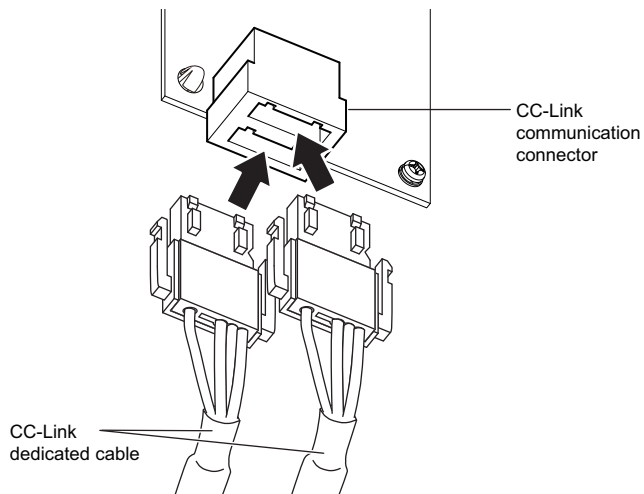

3

CAUTION

- Take caution not to subject the cables to stress.
- After wiring, do not leave wire offcuts in the inverter. Doing so may cause an alarm, failure or malfunction.

3.1.3 Unit replacement while online

Connect an online communication connector to the CC-Link communication connector. The online communication connector enables a unit replacement without interrupting the communication. Always connect the online communication connector to connector 1 (front side) of the CC-Link communication connector. (Do not connect it to connector 2 (back side) of the CC-Link communication connector. Doing so will cause a failure or breakage of the inverter and the connectors.) Connect a one-touch connector plug with terminating resistor to the CC-Link communication connector of FR-A8NC at the end station.

(A replacement while online is not available for the units, which are using the built-in terminating resistor selection switches. (Refer to [page 21](#).))

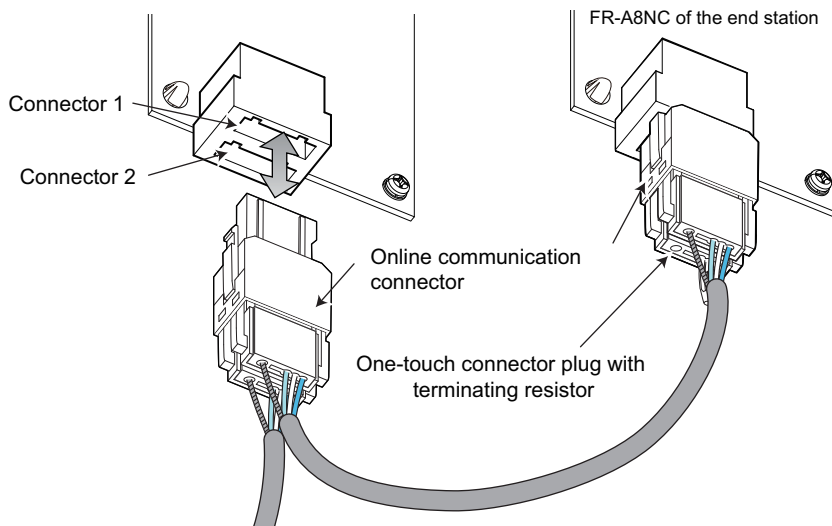

Use the following online communication connector and one-touch connector plug with terminating resistor.

- Online communication connector (as of October 2018) (The product may be changed without notice.)

Model	Manufacturer
35715-L010-B00 AK	3M Japan Limited

- One-touch connector plug with terminating resistor (as of October 2018) (The product may be changed without notice.)

Model	Manufacturer
A6CON-TR11N	Mitsubishi Electric Corporation



NOTE

- Do not use the online communication connector A6CON-LJ5P (Mitsubishi Electric Corporation) and 35720-L200-B00 AK (3M Japan Limited) for this product. Doing so will cause a failure or breakage of the inverter and the connectors.

3.2 System configuration example

1. Programmable controller side
Load the "RJ61BT11", "QJ61BT11N", "L26CPU-BT", "L26CPU-PBT", "LJ61BT11", "A1SJ61QBT11" or "A1SJ61BT11" type CC-Link system master/local module on the main or extension base unit having the programmable controller CPU used as the master station.
2. Inverter side
Mount the plug-in option (FR-A8NC) on the inverter.
3. Connect the master station of the CC-Link programmable controller unit to the CC-Link communication connector of FR-A8NC with the CC-Link dedicated cable.

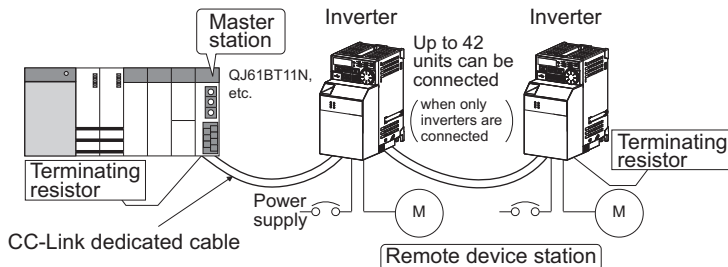
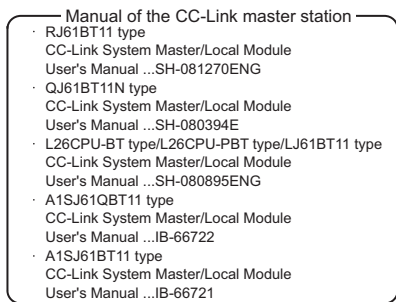

NOTE

- When the CPU has automatic refresh function (example: QnA series CPU)
When the END instruction is executed by the programmable controller CPU, the buffer memory is automatically refreshed to enable communication with a remote device.
- When the CPU does not have automatic refresh function (example: AnA series CPU)
Sequence ladder logic is configured to perform direct communication with the buffer memory of the master station and to enable communication with a remote device

3.3 Connection of several inverters

An inverter can join the link system as a CC-Link remote device station, and such device stations can be controlled and monitored with a user program of a programmable controller. These devices can be useful components of an automated factory.

Connect shielding wires of the CC-Link dedicated cable to "SLD" of each unit.

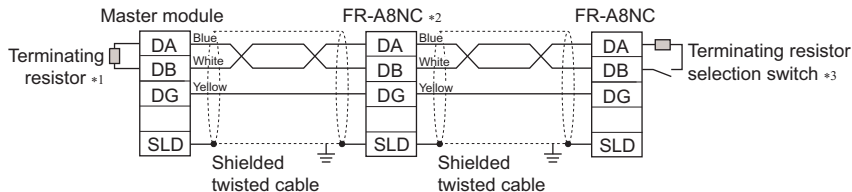

*1 Use the terminating resistors supplied with the programmable controller.

*2 Set "1" and "2" of the terminating resistor selection switch to OFF (without terminating resistor) in the middle units. (Refer to [page 21](#).)

*3 Set the terminating resistor selection switch. (Refer to [page 21](#).)

Do not use the built-in terminating resistor selection switch when using a one-touch connector plug with terminating resistor. (1-OFF, 2-OFF) (Refer to [page 28](#) for the details of the one-touch connector plug with terminating resistor.)

◆ Maximum number of units connected to one master station (CC-Link Ver.1.10)

42 units (when connections are inverters only)

If any other units are included, the number of stations occupied depends on the unit and therefore the following conditions must be satisfied:

$$\bullet \{(1 \times a) + (2 \times b) + (3 \times c) + (4 \times d)\} \leq 64$$

a: Number of units occupying 1 station c: Number of units occupying 3 stations

b: Number of units occupying 2 stations d: Number of units occupying 4 stations

$$\bullet \{(16 \times A) + (54 \times B) + (88 \times C)\} \leq 2304$$

A: Number of remote I/O ≤ 64

B: Number of remote device stations ≤ 42

C: Number of local, standby master and intelligent device stations ≤ 26

◆ Maximum number of units connected to one master station (CC-Link Ver.2.00)

42 units (when connections are inverter only)

If any other units are included, the number of stations occupied depends on the unit and therefore the following conditions must be satisfied:

- $\{(a + a2 + a4 + a8) + (b + b2 + b4 + b8) \times 2 + (c + c2 + c4 + c8) \times 3 + (d + d2 + d4 + d8) \times 4\} \leq 64$
- $\{(a \times 32 + a2 \times 32 + a4 \times 64 + a8 \times 128) + (b \times 64 + b2 \times 96 + b4 \times 192 + b8 \times 384) + (c \times 96 + c2 \times 160 + c4 \times 320 + c8 \times 640) + (d \times 128 + d2 \times 224 + d4 \times 448 + d8 \times 896)\} \leq 8192$
- $\{(a \times 4 + a2 \times 8 + a4 \times 16 + a8 \times 32) + (b \times 8 + b2 \times 16 + b4 \times 32 + b8 \times 64) + (c \times 12 + c2 \times 24 + c4 \times 48 + c8 \times 96) + (d \times 16 + d2 \times 32 + d4 \times 64 + d8 \times 128)\} \leq 2048$

a: Number of single setting devices occupying one station

b: Number of single setting devices occupying two stations

c: Number of single setting devices occupying three stations

d: Number of single setting devices occupying four stations

a2: Number of double setting devices occupying one station

b2: Number of double setting devices occupying two stations

c2: Number of double setting devices occupying three stations

d2: Number of double setting devices occupying four stations

a4: Number of quadruple setting devices occupying one station

b4: Number of quadruple setting devices occupying two stations

c4: Number of quadruple setting devices occupying three stations

d4: Number of quadruple setting devices occupying four stations

a8: Number of octuple setting devices occupying one station

b8: Number of octuple setting devices occupying two stations

c8: Number of octuple setting devices occupying three stations

d8: Number of octuple setting devices occupying four stations

- $16 \times A + 54 \times B + 88 \times C \leq 2304$

A: Numbers of remote I/O ≤ 64

B: Number of remote device stations ≤ 42

C: Number of local and intelligent device stations ≤ 26

4 INVERTER SETTING

4.1 Parameter list

The following parameters are used for the plug-in option (FR-A8NC).
Set the values according to need.

Pr.	Pr. group	Name	Setting range	Minimum setting increments	Initial value	Refer to page
79	D000	Operation mode selection	0 to 4, 6, 7	1	0	35
313 ^{*1}	M410 ^{*1}	DO0 output selection	*4	1	9999	65
314 ^{*1}	M411 ^{*1}	DO1 output selection				
315 ^{*1}	M412 ^{*1}	DO2 output selection				
338	D010	Communication operation command source	0, 1	1	0	*4
339	D011	Communication speed command source	0, 1, 2	1	0	*4
340	D001	Communication startup mode selection	0, 1, 10	1	[E800] 0 [E800-(SC)E] 10	35
342	N001	Communication EEPROM write selection	0, 1	1	0	*4
349 ^{*1}	N010 ^{*1}	Communication reset selection	0, 1	1	0	45
500 ^{*1}	N011 ^{*1}	Communication error execution waiting time	0 to 999.8 s	0.1 s	0 s	38
501 ^{*1}	N012 ^{*1}	Communication error occurrence count display	0	1	0	39
502	N013	Stop mode selection at communication error	0 to 2, 6	1	0	39
541 ^{*1}	N100 ^{*1}	Frequency command sign selection	0, 1	1	0	48
542 ^{*1*2*3}	N101 ^{*1*2*3}	Communication station number (CC-Link)	1 to 64	1	1	46

Pr.	Pr. group	Name	Setting range	Minimum setting increments	Initial value	Refer to page
543 ^{*1*2*3}	N102 ^{*1*2*3}	Baud rate selection (CC-Link)	0 to 4	1	0	48
544 ^{*1*2}	N103 ^{*1*2}	CC-Link extended setting	0, 1, 12, 14, 18, 100, 112, 114, 118	1	0	53
550 ^{*2}	D012 ^{*2}	NET mode operation command source selection	[E800] 0, 2, 9999 [E800-(SC)E] 0, 5, 9999	1	9999	*4
779	N014	Operation frequency during communication error	0 to 590 Hz, 9999	0.01 Hz	9999	39
804	D400	Torque command source selection	0, 1, 3 to 6	1	0	79
810	H700	Torque limit input method selection	0 to 2	1	0	79

*1 Parameters which can be displayed when the plug-in option (FR-A8NC) is mounted. (Pr.313 to Pr.315, Pr.349, Pr.541, and Pr.544 are always available for setting in the Ethernet model or the safety communication model.)

*2 The setting is reflected after inverter reset or at the next power-on.

*3 "L.ERR" LED blinks if the setting is changed. If the inverter is reset, the setting is reflected and the LED turns off.

*4 For the parameter details, refer to the FR-E800 Instruction Manual (Function).

4.2 Operation mode setting

4.2.1 Operation mode switching and communication startup mode (Pr.79, Pr.340)

◆ Operation mode switching conditions

Check the following before switching the operation mode.

- The inverter is at a stop.
- Both the STF and STR signals are off.
- The **Pr.79 Operation mode selection** setting is correct.

(Check the setting on the operation panel of the inverter.)

◆ Operation mode selection at power ON and at restoration from instantaneous power failure

The operation mode at power ON and at restoration from instantaneous power failure can be selected.

Set a value other than "0" in **Pr.340 Communication startup mode selection** to select the network operation mode.

After started in network operation mode, parameter write from the network is enabled.

(Refer to [page 90](#) for a program example for parameter write.)

NOTE

- Change of the **Pr.340** setting is valid when powering on or resetting the inverter.
- **Pr.340** can be changed with the operation panel independently of the operation mode.
- Ensure that the communication setting of the inverter is completed before setting **Pr.340** ≠ "0".
- For the details of **Pr.79** and **Pr.340**, refer to the FR-E800 Instruction Manual (Function).

Pr.340 setting	Pr.79 setting	Operation mode at power ON or power restoration	Operation mode switchover
0	0 (initial value)	External operation mode	Switching among the External, PU, and NET operation mode is enabled. *1*3
	1	PU operation mode	PU operation mode fixed
	2	External operation mode	Switching between the External and Net operation mode is enabled. *3 Switching to the PU operation mode is disallowed.
	3, 4	External/PU combined operation mode	Operation mode switching is disallowed.
	6*4	External operation mode	Switching among the External, PU, and NET operation mode is enabled while running. *3
	7	X12 (MRS) signal ON: external operation mode	Switching among the External, PU, and NET operation mode is enabled. *1*3
X12 (MRS) signal OFF: external operation mode		External operation mode fixed (Forcibly switched to External operation mode.)	
1	0	NET operation mode	Same as when Pr.340 = "0"
	1	PU operation mode	
	2	NET operation mode	
	3, 4	External/PU combined operation mode	
	6*4	NET operation mode	
	7	X12 (MRS) signal ON: NET operation mode	
X12 (MRS) signal OFF: external operation mode			

Pr.340 setting	Pr.79 setting	Operation mode at power ON or power restoration	Operation mode switchover
10	0	NET operation mode	Switching between the PU and NET operation mode is enabled. *2*3
	1	PU operation mode	Same as when Pr.340 = "0"
	2	NET operation mode	NET operation mode fixed
	3, 4	External/PU combined operation mode	Same as when Pr.340 = "0"
	6*4	NET operation mode	Switching between the PU and NET operation mode is enabled while running. *2*3
	7	External operation mode	Same as when Pr.340 = "0"

*1 Operation mode cannot be directly changed between the PU operation mode and Network operation mode.

*2 Switching between the PU and NET operation modes is available with the key on the operation panel or the X65 signal.

*3 Refer to [page 74](#) for a switching method from the network.

*4 When Pr.128 = "50, 51, 60, or 61", the same operation mode as when Pr.79 = "0" is selected.

4.3 Operation at communication error occurrence

4.3.1 Operation selection at communication error occurrence (Pr.500 to Pr.502, Pr.779)

You can select operations at communication error occurrences by setting **Pr.500 to Pr.502, Pr.779** under network operation.

◆ **Waiting time for the communication line error output after a communication error**

Waiting time for the communication error output after a communication line error occurrence can be set.

Pr.	Name	Setting range	Minimum setting increments	Initial value
500	Communication error execution waiting time	0 to 999.8 s	0.1 s	0s

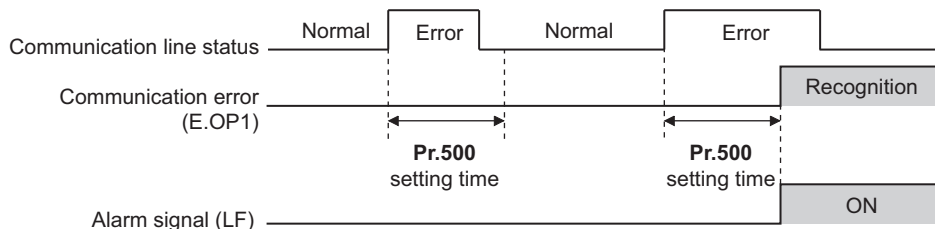

When a communication line error occurs and lasts longer than the time set in **Pr.500**, it is recognized as a communication error. If the communication returns to normal within the time, it is not recognized as a communication error, and the operation continues.

◆ Displaying and clearing the communication error count

The cumulative count of communication error occurrences can be displayed. Write "0" to clear this cumulative count.

Pr.	Name	Setting range	Minimum setting increments	Initial value
501	Communication error occurrence count display	0	1	0

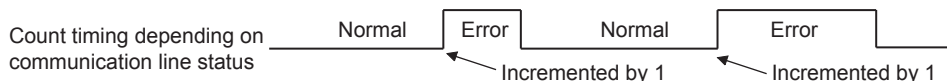

At the point of communication line error occurrence, **Pr.501 Communication error occurrence count display** is incremented by 1.

The cumulative count of communication error occurrences is counted from 0 to 65535. When the count exceeds 65535, the displayed value is cleared and the counting starts over from 0 again.

NOTE

- Communication error count is temporarily stored in the RAM memory. The error count is stored in EEPROM only once per hour. If power reset or converter reset is performed, **Pr.501** setting will be the one that is last stored to EEPROM depending on the reset timing.

◆ Inverter operation at a communication error occurrence

How the inverter operates at a communication line error or an option unit fault can be set.

Pr.	Name	Setting range	Description
502	Stop mode selection at communication error	0 (Initial Value), 1, 2, 6	Refer to page 40
779*1	Operation frequency during communication error	0 to 590 Hz	When a communication error occurs, the inverter operates at the set frequency.
		9999 (Initial Value)	The inverter operates at the frequency set before the communication error occurs.

*1 Valid when **Pr.502** = "6".

◆ About setting

- Operation at an error occurrence

Fault description	Pr.502 setting	Operation	Indication	Fault output
Communication line	0	Continued ^{*1}	Normal ^{*1}	Not output ^{*1}
	1			
	2			
	6			
Communication option	0	Output shutoff	"E. 1"	Provided
	1, 2	Output to decelerate and stop the motor	"E. 1" after stop	Provided after stop
	6	Operation continued at the set frequency of Pr.779 ^{*2}	"CF" warning	Not output

*1 When the communication returns to normal within the time period set in **Pr.500**, the communication option error (E.OP1) does not occur.

*2 Under position control, the operation is continued to the target position. When the communication operation command source is changed to the External mode and the LX signal is not input via an external input terminal, the inverter output is shut off.

- Operation after the time in **Pr.500** elapses after an error occurrence

Fault description	Pr.502 setting	Operation	Indication	Fault output
Communication line	0	Output shutoff	"E.OP1"	Provided
	1	Output to decelerate and stop the motor	"E.OP1" after stop	Provided after stop
	2			
	6	Operation continued at the set frequency of Pr.779 ^{*4}	"CF" warning	Not output
Communication option itself	0	Output stop status continues. ^{*3}	"E.1" kept ^{*3}	Kept provided ^{*3}
	1, 2			
	6	Operation continued at the set frequency of Pr.779 ^{*4*5}	"CF" warning	Not output

*3 When an error occurs, the inverter outputs a command to decelerate the motor or shuts off the output, and outputs the fault, independently of the **Pr.500** setting.

*4 When the frequency command source is changed from NET to any other source, frequency commands given from an external device are enabled.

*5 Under position control, the operation is continued to the target position. When the communication operation command source is changed to the External mode and the LX signal is not input via an external input terminal, the inverter output is shut off.

- Operation at error removal

Fault description	Pr.502 setting	Operation	Indication	Fault output
Communication line	0	Output stop status continues.	"E.OP1" kept	Kept provided
	1			
	2	Restart ^{*6}	Normal	Not output
6	Normal			
Communication option itself	0	Output stop status continues.	"E. 1" kept	Kept provided
	1, 2			
	6	Operation continued at the set frequency of Pr.779 ^{*7}	"CF" warning	Not output

*6 When the communication error is removed during deceleration, the motor re-accelerates.

*7 Under position control, the motor does not re-accelerate even when the communication error is removed during deceleration.

NOTE

- The protective function [E.OP1 (fault data: HA1)] is activated at error occurrences on the communication line. The protective function [E.1 (fault data: HF1)] is activated at error occurrences in the communication circuit inside the option.
- Fault output indicates the fault (ALM) signal and fault bit output.
- When the fault output setting is active, fault records are stored in the fault history. (A fault record is written to the fault history at a fault output.)
- When the fault output setting is not active, fault record is overwritten to the fault history temporarily but not stored. After the error is removed, the fault indication is reset, changing the display back to normal, and the last fault is displayed in the fault history.
- When **Pr.502** is set to "1, 2", the normal deceleration time setting (such as **Pr.8/Pr.44/Pr.45** setting) is applied. The **Pr.464** or **Pr.1223** deceleration time setting, whichever is smaller, is applied for position control.
- When a communication line error occurs while **Pr.502** = "2", the motor re-accelerates if the error is removed during deceleration. The operation command and the speed command before the fault occurred will be applied for restarting. The normal acceleration time setting (such as **Pr.7/Pr.44** setting) is applied for restart. (Acceleration is not restarted if the error is that of the option unit itself.)

CAUTION

- When **Pr.502** = "6", operation continues even if a communication option fault (E.OP1) or an option fault (E.1) is displayed. When setting "6" in **Pr.502**, provide a safety stop countermeasure other than via communication. For example, input a signal through an external terminal (RES, MRS, or X92) or press the PU stop on the operation panel.

4.3.2 Fault and measures

◆ Inverter operation in each operation mode at error occurrences

Location	Status		Operation mode		
			Network operation ^{*1}	External operation	PU operation
Inverter	Inverter operation		Output shutoff	Output shutoff	Output shutoff
	Data communication		Continued	Continued	Continued
Communication line	Inverter operation		Output shutoff ^{*2}	Continued	Continued
	Data communication		Stop	Stop	Stop
Communication option	Communication option connection error	Inverter operation	Output shutoff ^{*2}	Output shutoff ^{*2}	Output shutoff ^{*2}
		Data communication	Continued	Continued	Continued
	Error of communication option itself	Inverter operation	Output shutoff ^{*2}	Continued	Continued
		Data communication	Stop	Stop	Stop

*1 When the communication option is set as the operation command source.

*2 Depends on the Pr.502 setting.

◆ Measures at error occurrences

Fault indication	Name	Measures
E.OP1	Communication option fault	<ul style="list-style-type: none"> • Check the LED status of the option unit and remove the cause of the alarm (Refer to page 97 for LED indication status). • Inspect the master.
E.1	Option fault	<ul style="list-style-type: none"> • Check the connection between the inverter and option unit for poor contact, etc. and remove the cause of the error.

*1 When a fault other than the above is displayed, refer to the FR-E800 Instruction Manual (Maintenance) to remove the cause of the fault.

4.4 Inverter reset

◆ Operation conditions of inverter reset

Which resetting method is allowed or not allowed in each operation mode is described below.

Resetting method		Operation mode		
		Network operation	External operation	PU operation
Reset from the network	Inverter reset (Refer to page 74.)*1	Allowed	Disallowed	Disallowed
	Error reset (RY1A) at inverter fault (Refer to page 62.)*2	Allowed	Allowed	Allowed
			Disallowed	Disallowed
Turn on the RES signal (terminal RES) of the inverter		Allowed	Allowed	Allowed
Switch off inverter power		Allowed	Allowed	Allowed
Reset on the operation panel	Inverter reset	Allowed	Allowed	Allowed
	Reset at inverter fault	Allowed	Allowed	Allowed

*1 Inverter reset can be made any time.

*2 Reset can be made only when the protective function of the inverter is activated.

NOTE

- When a communication line error has occurred, reset cannot be made from the network.
- The inverter is set to the External operation mode if it has been reset in Network operation mode in the initial status. To resume the network operation, the inverter must be switched to the Network operation mode again. Set a value other than "0" in **Pr.340** to start in the Network operation mode. (Refer to [page 35.](#))
- Communication continues during inverter reset. (The inverter cannot be controlled for about 1 s after release of a reset command.)
- Refer to [page 94](#) for an inverter reset program example.

◆ Error reset operation selection at inverter fault

An error reset command from communication option can be invalid in the External operation mode or PU operation mode. Use RY1A for an error reset command from network. (Refer to [page 62](#).)

Pr.	Name	Initial value	Setting range	Function
349	Communication reset selection	0	0	Error reset is enabled independently of operation mode.
			1	Error reset is enabled only in the network operation mode.

4.5 CC-Link function setting

4.5.1 Station number setting (Pr.542)

Use **Pr.542 Communication station number (CC-Link)** to set station number of the inverter. Set this parameter within the range of 1 to 64.

Pr.	Name	Initial value	Setting range
542	Communication station number (CC-Link)	1	1 to 64

NOTE

- Use different station numbers for different devices. (If different devices have the same station number, the communication cannot be performed properly.)

◆ Connection example

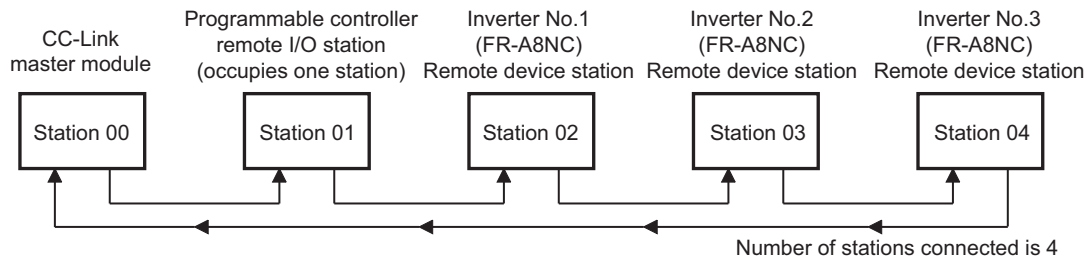

 **NOTE**

- Set consecutive numbers for the station numbers. (Do not skip a number in sequence like "station number 1 - station number 2- station number 4".) The station number does not have to match with the physical connection sequence. (There is no problem with having the physical connection sequence like "station number 1 - station number 3 - station number 4 - station number 2".)
 - One inverter occupies one station. (One remote device station)
 - "L.ERR" LED blinks if the setting is changed. When power is switched on again or the RES signal is turned on, the setting value is reflected and the LED turns off.
-

4.5.2 Baud rate setting (Pr.543)

Set the transmission speed. (Refer to the manual for the CC-Link master module for details of transmission speed.)

Pr.	Name	Initial value	Setting range	Transmission speed
543	Baud rate selection (CC-Link)	0	0	156 kbps
			1	625 kbps
			2	2.5 Mbps
			3	5 Mbps
			4	10 Mbps

NOTE

- "L.ERR" LED blinks if the setting is changed. When power is switched on again or the RES signal is turned on, the setting value is reflected and the LED turns off.

4.5.3 Frequency command with sign (Pr.541)

By frequency command with sign, start command (forward rotation/reverse rotation) can be inverted to operate. Make selection of sign for the frequency command from RWw1.

Pr.	Name	Initial value	Setting range
541	Frequency command sign selection	0	0, 1

Speed setting using Pr.37 and Pr.53	Pr.541 setting	Sign	Setting range	Actual frequency command
Not used	0	Not used	0 to 59000	0 to 590.00 Hz
	1	With	-32768 to 32767 (two's complement)	-327.68 to 327.67 Hz
With	0	Not used	0 to 65535	The rotation speed command or the machine speed command is selected depending on the Pr.37 and Pr.53 settings. (The increment is 1 for each parameter.)
	1	With	-32768 to 32767 (two's complement)	

- Relationship between the start command and sign (**Pr.541** = "1")

Start command	Sign of the frequency command	Actual run command
Forward rotation	+	Forward rotation
	-	Reverse rotation
Reverse rotation	+	Reverse rotation
	-	Forward rotation

NOTE

- When **Pr.541** = 1 (with sign)

When EEPROM write is specified with the RYE, write mode error (error code H01) will occur. When concurrent execution of both RYD and RYE is enabled (when a value other than 0 is set in **Pr.544**) and both RYD and RYE are turned on, RYD has precedence. When power is turned on (inverter reset), the initial setting status of the sign bit is "positive" and the set frequency is "0 Hz". (The motor does not operate at the frequency set before turning OFF the power (inverter reset).) When set frequency is written with the instruction code of HED and HEE, the sign of the frequency command is not changed.

5 FUNCTION OVERVIEW

5.1 Function block diagram

Using function blocks, this section explains I/O data transfer to/from an inverter in CC-Link:

- Link refresh is continuously executed between the master station and inverter in the CC-Link system at intervals of 1.1 ms to 141 ms (per station).

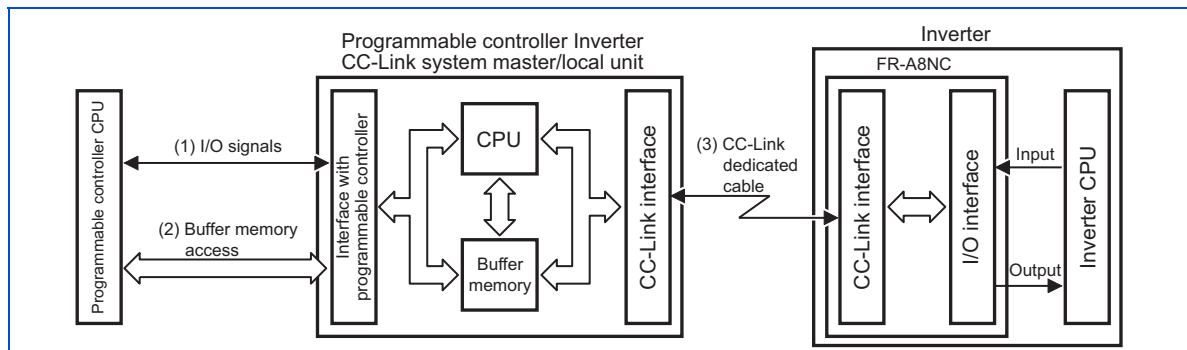

1. These are I/O signals assigned to the CC-Link system master/local unit. These signals are used for communication between the programmable controller CPU and CC-Link system master/local unit. Refer to [page 62](#) for details of the signal.
2. Regarding the data input to the inverter, writing of inverter output data, and reading of a faulty CC-Link station are available. Automatic refresh function enables reading from/writing to buffer memory. (Use FROM/TO command of the sequence program to synchronize without using the automatic refresh function.) Refer to CC-Link master/local module manual for the buffer memory details.
3. CC-Link communication start command is given from the sequence program. After the CC-Link communication starts, link refresh is always performed asynchronously (or synchronously) with execution of sequence program. For details, refer to the CC-Link system master/local unit manual.

5.2 Output from the inverter to the network

Main items which can be output from the inverter to the master and their descriptions are explained below.

Item	Description	Refer to page
Inverter status monitor	The output terminal status of the inverter can be monitored.	65
Output frequency monitor	The output frequency can be monitored.	70, 74
Output current monitor	The output current can be monitored.	74
Output voltage monitor	The output voltage can be monitored.	74
Special monitor	The monitor data selected can be checked.	74
Fault history	Fault records can be checked.	70, 74
Data at alarm occurrence	The inverter status at alarm occurrence can be checked.	70
Operation Mode	The current operation mode can be checked.	74
Parameter read	Parameter settings can be read.	74
Read of set frequency	The current set frequency can be read.	74



NOTE

- For the functions operable via network in each operation mode, refer to the FR-E800 Instruction Manual (Function).

5.3 Input to the inverter from the network

Main items which can be commanded from the master to the inverter and their descriptions are explained below.

Item	Description	Refer to page
Forward rotation command	Give the forward rotation command.	62
Reverse rotation command	Give the reverse rotation command.	62
Input terminal function command	Execute functions assigned to the inverter input terminals.	62
Inverter output stop command	Stop the inverter output.	62
Error reset	Reset the inverter only when an inverter alarm occurs.	62
Frequency (torque command / torque limit) setting	Set the frequency (torque command / torque limit).	67, 74
Monitor command	Specify the description monitored.	67, 74
Operation mode specification	Set the operation mode.	74
Fault history clear	Erase past ten fault records.	74
All parameter clear	Return the parameter descriptions to the initial value.	74
Inverter reset	Reset the inverter.	74
Parameter write	Write parameter settings.	74
PID control	PID set point, PID measured value and PID deviation can be input from the network.	67

NOTE

- For the functions operable via network in each operation mode, refer to the FR-E800 Instruction Manual (Function).

6 I/O SIGNAL LIST

6.1 CC-Link extended setting (Pr.544)

Remote register function can be extended.

Pr.	Name	Initial value	Setting range	CC-Link Ver.	Description	Refer to page	
544	CC-Link extended setting	0	0	1	Occupies one station (FR-A5NC compatible) ^{*1}	54	
			1		Occupies one station	57	
			12 ^{*2}	2	Occupies one station double	58	
			14 ^{*2}		Occupies one station quadruple	59	
			18 ^{*2}		Occupies one station octuple	60	
			100	1	Occupies one station	PLC function	- ^{*3}
			112 ^{*2}	2	Occupies one station double		
			114 ^{*2}		Occupies one station quadruple		
			118 ^{*2}		Occupies one station octuple		

*1 The program used for conventional series inverter (FR-A5NC) can be used.

When RYD, RYE, and RYF turn on simultaneously, only one of them is executed.

The upper 8 bits of RWw2 are link parameter extended setting.

*2 When using double, quadruple and octuple settings of the CC-Link Ver.2, station data of the master station must be set to double, quadruple and octuple also.

(If the master station is CC-Link Ver.1 compatible station, the above setting can not be made.)

*3 Refer to the PLC function programming manual.

NOTE

- The setting change is reflected after an inverter reset. (Refer to [page 44](#) for inverter reset.)

6.2 I/O signal list

6.2.1 I/O signal when CC-Link Ver.1 one station (FR-A5NC compatible) is occupied (Pr.544 = 0)

◆ Remote I/O (32 points)

Device no. ^{*5}	Signal	Refer to page
RYn0	Forward rotation command ^{*2}	62
RYn1	Reverse rotation command ^{*2}	62
RYn2	High-speed operation command (terminal RH function) ^{*1}	62
RYn3	Middle-speed operation command (terminal RM function) ^{*1}	62
RYn4	Low-speed operation command (terminal RL function) ^{*1}	62
RYn5	JOG operation selection 2 (JOG2 signal) ^{*2}	62
RYn6	Second function selection (RT signal) ^{*2}	62
RYn7	Current input selection (AU signal) ^{*2}	62
RYn8	No function (terminal NET X1 function) ^{*1}	62
RYn9	Output stop (Terminal MRS function) ^{*1}	62
RYnA	No function (terminal NET X2 function) ^{*1}	62
RYnB	Reset (terminal RES function) ^{*1}	62
RYnC	Monitor command	62

Device no. ^{*5}	Signal	Refer to page
RXn0	Forward running	65
RXn1	Reverse running	65
RXn2	Running (terminal RUN function) ^{*3}	65
RXn3	Up to frequency (SU signal) ^{*2}	65
RXn4	Overload alarm (OL signal) ^{*2}	65
RXn5	No function (terminal NET Y1 function) ^{*3}	65
RXn6	Frequency detection (terminal FU function) ^{*3}	65
RXn7	Error (terminal ABC function) ^{*3}	65
RXn8	No function (terminal NET Y2 function) ^{*3}	65
RXn9	Pr.313 assignment function (DO0) ^{*4}	65
RXnA	Pr.314 assignment function (DO1) ^{*4}	65
RXnB	Pr.315 assignment function (DO2) ^{*4}	65
RXnC	Monitoring	65

Device no. ^{*5}	Signal	Refer to page
RYnD	Frequency setting command (RAM)	62
RYnE	Frequency setting command (RAM, EEPROM)	62
RYnF	Instruction code execution request	62
RY(n+1)0 to RY(n+1)7	Reserved	—
RY(n+1)8	Not used (initial data process completion flag)	—
RY(n+1)9	Not used (initial data process request flag)	—
RY(n+1)A	Error reset request flag	62
RY(n+1)B	No function (terminal NET X3 function) ^{*1}	62
RY(n+1)C	No function (terminal NET X4 function) ^{*1}	62
RY(n+1)D	No function (terminal NET X5 function) ^{*1}	62
RY(n+1)E	Reserved	—
RY(n+1)F		

Device no. ^{*5}	Signal	Refer to page
RXnD	Frequency setting completion (RAM)	65
RXnE	Frequency setting completion (RAM, EEPROM)	65
RXnF	Instruction code execution completion	65
RX(n+1)0 to RX(n+1)5	Reserved	—
RX(n+1)6	No function (terminal NET Y3 function) ^{*3}	65
RX(n+1)7	No function (terminal NET Y4 function) ^{*3}	65
RX(n+1)8	Not used (initial data process request flag)	—
RX(n+1)9	Not used (initial data process completion flag)	—
RX(n+1)A	Error status flag	65
RX(n+1)B	Remote station ready	65
RX(n+1)C	In-position (Y36 signal) ^{*2}	65
RX(n+1)D	During position command operation (PBSY signal) ^{*2}	65
RX(n+1)E	Home position return completed (ZP signal) ^{*2}	65
RX(n+1)F	Home position return failure (ZA signal) ^{*2}	65

^{*1} These signals are set in the initial status. Using **Pr.180 to Pr.189**, you can change input signal functions. For details of **Pr.180 to Pr.189**, refer to the FR-E800 Instruction Manual (Function).

- *2 The signals are fixed. They cannot be changed using parameters.
- *3 These signals are set in the initial status. Using **Pr.190 to Pr.196**, you can change output signal functions.
For the details of **Pr.190 to Pr.196**, refer to the FR-E800 Instruction Manual (Function).
- *4 Output signal can be assigned using **Pr.313 to Pr.315**.
For details of **Pr.313 to Pr.315**, refer to the FR-E800 Instruction Manual (Function).
- *5 "n" indicates a value determined according to the station number setting.

◆ Remote register

Address ^{*3}	Description		Refer to page	Address ^{*3}	Description	Refer to page
	Upper 8 bits	Lower 8 bits				
RWwn	Monitor code 2	Monitor code 1	67	RWrn	First monitor value	70
RWwn+1	Set frequency (0.01 Hz increments)/ torque command ^{*2}		67	RWrn+1	Second monitor value	70
RWwn+2	H00 (arbitrary) ^{*1}	Instruction code	67	RWrn+2	Reply code	70
RWwn+3	Write data		67	RWrn+3	Read data	70

*1 The above 8 bit is always H00 even if a value other than H00 is set.

*2 When **Pr.804** = "3 or 5" during torque control under Real sensorless vector control, a torque command value is set in RWwn+1.

*3 "n" indicates a value determined according to the station number setting.

6.2.2 I/O signal when CC-Link Ver.1 one station is occupied (Pr.544 = 1)

◆ Remote I/O (32 points)

Same as when Pr.544 = 0 (Refer to [page 54](#))

◆ Remote register

Address*2	Description		Refer to page
	Upper 8 bits	Lower 8 bits	
RWwn	Monitor code 2	Monitor code 1	67
RWwn+1	Set frequency (0.01 Hz increments)/ torque command*1		67
RWwn+2	Link parameter extended setting	Instruction code	67
RWwn+3	Write data		67

Address*2	Description		Refer to page
	Upper 8 bits	Lower 8 bits	
RWrn	First monitor value		70
RWrn+1	Second monitor value		70
RWrn+2	Reply code 2	Reply code 1	70
RWrn+3	Read data		70

*1 When Pr.804 = "3 or 5" during torque control under Real sensorless vector control, a torque command value is set in RWwn+1.

*2 "n" indicates a value determined according to the station number setting.

6.2.3 I/O signal when CC-Link Ver.2 double setting is selected (Pr.544 = 12)

◆ Remote I/O (32 points)

Same as when Pr.544 = 0 (Refer to [page 54](#))

◆ Remote register

Address*2	Description		Refer to page	Address*2	Description		Refer to page
	Upper 8 bits	Lower 8 bits			Upper 8 bits	Lower 8 bits	
RWwn	Monitor code 2	Monitor code 1	67	RWrn	First monitor value		70
RWwn+1	Set frequency (0.01 Hz increments)/ torque command*1		67	RWrn+1	Second monitor value		70
RWwn+2	Link parameter extended setting	Instruction code	67	RWrn+2	Reply code 2	Reply code 1	70
RWwn+3	Write data		67	RWrn+3	Read data		70
RWwn+4	Monitor code 3		67	RWrn+4	Third monitor value		70
RWwn+5	Monitor code 4		67	RWrn+5	Fourth monitor value		70
RWwn+6	Monitor code 5		67	RWrn+6	Fifth monitor value		70
RWwn+7	Monitor code 6		67	RWrn+7	Sixth monitor value		70

*1 When Pr.804 = "3 or 5" during torque control under Real sensorless vector control, a torque command value is set in RWwn+1.

*2 "n" indicates a value determined according to the station number setting.

6.2.4 I/O signal when CC-Link Ver.2 quadruple setting is selected (Pr.544 = 14)

◆ Remote I/O (32 points (64 points occupied))

Same as when Pr.544 = 0 (Refer to [page 54](#))

◆ Remote register

Address ^{*2}	Description		Refer to page
	Upper 8 bits	Lower 8 bits	
RWwn	Monitor code 2	Monitor code 1	67
RWwn+1	Set frequency (0.01 Hz increments)		67
RWwn+2	Link parameter extended setting	Instruction code	67
RWwn+3	Write data		67
RWwn+4	Monitor code 3		67
RWwn+5	Monitor code 4		67
RWwn+6	Monitor code 5		67
RWwn+7	Monitor code 6		67
RWwn+8	Fault record No.	H00	67
RWwn+9	PID set point (0.01% increments) ^{*1}		67
RWwn+A	PID measured value (0.01% increments) ^{*1}		67
RWwn+B	PID deviation (0.01% increments) ^{*1}		67
RWwn+C	Torque command or torque limit		67, 79
RWwn+D			
RWwn+E	H00 (Free)		—
RWwn+F			

Address ^{*2}	Description		Refer to page
	Upper 8 bits	Lower 8 bits	
RWrm	First monitor value		70
RWrm+1	Second monitor value		70
RWrm+2	Reply code 2	Reply code 1	70
RWrm+3	Read data		70
RWrm+4	Third monitor value		70
RWrm+5	Fourth monitor value		70
RWrm+6	Fifth monitor value		70
RWrm+7	Sixth monitor value		70
RWrm+8	Fault record No.	Fault data	70
RWrm+9	Fault record (output frequency)		70
RWrm+A	Fault record (output current)		70
RWrm+B	Fault record (output voltage)		70
RWrm+C	Fault record (energization time)		70
RWrm+D			
RWrm+E	H00 (Free)		—
RWrm+F			

*1 Validity depends on the Pr.128, Pr.609, and Pr.610 settings. For details, refer to the FR-E800 Instruction Manual (Function). If the data outside the range is set, the previous setting is retained.

*2 "n" indicates a value determined according to the station number setting.

6.2.5 I/O signal when CC-Link Ver.2 octuple setting is selected (Pr.544 = 18)

◆ Remote I/O (32 points (128 points occupied))

Same as when Pr.544 = 0 (Refer to [page 54](#))

◆ Remote register

Address ^{*2}	Description		Refer to page
	Upper 8 bits	Lower 8 bits	
RWwn	Monitor code 2	Monitor code 1	67
RWwn+1	Set frequency (0.01 Hz increments)		67
RWwn+2	Link parameter extended setting	Instruction code	67
RWwn+3	Write data		67
RWwn+4	Monitor code 3		67
RWwn+5	Monitor code 4		67
RWwn+6	Monitor code 5		67
RWwn+7	Monitor code 6		67
RWwn+8	Fault record No.	H00	67
RWwn+9	PID set point (0.01% increments) ^{*1}		67
RWwn+A	PID measured value (0.01% increments) ^{*1}		67
RWwn+B	PID deviation (0.01% increments) ^{*1}		67
RWwn+C	Torque command or torque limit		67, 79
RWwn+D	H00 (Free)		—
RWwn+E			
RWwn+F			
RWwn+10	Link parameter extended setting	Instruction code	67
RWwn+11	Write data		67

Address ^{*2}	Description		Refer to page
	Upper 8 bits	Lower 8 bits	
RWrn	First monitor value		70
RWrn+1	Second monitor value		70
RWrn+2	Reply code 2	Reply code 1	70
RWrn+3	Read data		70
RWrn+4	Third monitor value		70
RWrn+5	Fourth monitor value		70
RWrn+6	Fifth monitor value		70
RWrn+7	Sixth monitor value		70
RWrn+8	Fault record No.	Fault data	70
RWrn+9	Fault record (output frequency)		70
RWrn+A	Fault record (output current)		70
RWrn+B	Fault record (output voltage)		70
RWrn+C	Fault record (energization time)		70
RWrn+D	H00 (Free)		—
RWrn+E			
RWrn+F			
RWrn+10	Reply code		70
RWrn+11	Read data		70

Address ^{*2}	Description		Refer to page
	Upper 8 bits	Lower 8 bits	
RWwn+12	Link parameter extended setting	Instruction code	67
RWwn+13	Write data		67
RWwn+14	Link parameter extended setting	Instruction code	67
RWwn+15	Write data		67
RWwn+16	Link parameter extended setting	Instruction code	67
RWwn+17	Write data		67
RWwn+18	Link parameter extended setting	Instruction code	67
RWwn+19	Write data		67
RWwn+1A	H00 (Free)		-
RWwn+1B			
RWwn+1C			
RWwn+1D			
RWwn+1E			
RWwn+1F			

Address ^{*2}	Description		Refer to page
	Upper 8 bits	Lower 8 bits	
RWrm+12	Reply code		70
RWrm+13	Read data		70
RWrm+14	Reply code		70
RWrm+15	Read data		70
RWrm+16	Reply code		70
RWrm+17	Read data		70
RWrm+18	Reply code		70
RWrm+19	Read data		70
RWrm+1A	H00 (Free)		-
RWrm+1B			
RWrm+1C			
RWrm+1D			
RWrm+1E			
RWrm+1F			

*1 Validity depends on the **Pr.128**, **Pr.609**, and **Pr.610** settings. For details, refer to the FR-E800 Instruction Manual (Function). If the data outside the range is set, the previous setting is retained.

*2 "n" indicates a value determined according to the station number setting.

7 DETAILS OF INPUT AND OUTPUT SIGNALS

The following device No. are those for station 1. For stations 2 and later, the device No. are different. (Refer to the master module manual for correspondence between the device No. and station number)

7.1 Details of remote input and output signals

7.1.1 Output signals (master module to inverter (FR-A8NC))

The output signals from the master module are indicated. (Input signals to inverter)

Device no.	Signal	Description	
RY0	Forward rotation command *2	0: Stop command 1: Forward rotation start	When "1" is set, a start command is input to the inverter. When "1" is set in RY0 and RY1, a stop command is input.
RY1	Reverse rotation command *2	0: Stop command 1: Reverse rotation start	
RY2	High-speed operation command (terminal RH function)*1	Functions assigned to Pr.180 to Pr.182 are activated.	
RY3	Middle-speed operation command (terminal RM function)*1		
RY4	Low-speed operation command (terminal RL function)*1		
RY5	JOG operation selection 2 (JOG2 signal)*2	1: JOG operation is selected	
RY6	Second function selection (RT signal)*2	1: The second function is selected.	
RY7	Current input selection (AU signal)*2	1: Terminal 4 is used to input the main speed setting.	
RY8	-(NET X1 function)*1	The function assigned to Pr.185 is activated.	
RY9	Output stop (Terminal MRS function)*1	The function assigned to Pr.183 is activated.	
RYA	-(NET X2 function)*1	The function assigned to Pr.186 is activated.	

Device no.	Signal	Description
RYB	Reset (RES terminal function) ^{*1}	The function assigned to Pr.184 is activated.
RYC	Monitor command	When "1" is set in RYC, the monitored value is set in the remote register RWr0, 1, 4 to 7, and "1" is set in the monitoring (RXC). While "1" is set in RYC, the monitored data is always updated.
RYD ^{*4}	Frequency setting command / torque command (RAM)	When "1" is set in RYD, the set frequency/torque command (RWw1) is written to RAM of the inverter. ^{*3} After the writing completes, "1" is set in the frequency setting / torque command completion (RXD). Under Real sensorless vector control and PM sensorless vector control, the following value is also written to RAM at the same time. <ul style="list-style-type: none"> • During torque control^{*6}: Torque command value • During speed control / position control: Torque limit value
RYE ^{*4}	Frequency setting command / torque command (RAM, EEPROM)	When "1" is set in RYE, the set frequency/torque command (RWw1) is written to RAM and EEPROM of the inverter. After the writing completes, "1" is set in the frequency setting / torque command completion (RXE). Under Real sensorless vector control and PM sensorless vector control, the following value is also written to RAM and EEPROM at the same time. <ul style="list-style-type: none"> • During torque control^{*6}: Torque command value • During speed control / position control: Torque limit value To change the frequency consecutively, be sure to write data to the inverter RAM.
RYF ^{*4}	Instruction code execution request	When "1" is set in RYF, processes corresponding to the instruction codes set to RWw2, 10, 12, 14, 16 and 18 are executed. "1" is set in the instruction code execution request (RXF) after completion of instruction codes. When an instruction code execution error occurs, a value other than "0" is set in the reply code (RWr2, 10, 12, 14, 16, 18).
RY1A	Error reset request flag	When "1" is set in RY1A at an inverter fault, the inverter is reset, then "0" is set in the error status flag (RX1A). ^{*5}
RY1B	- (NET X3 function) ^{*1}	The function assigned to Pr.187 is activated.
RY1C	- (NET X4 function) ^{*1}	The function assigned to Pr.188 is activated.
RY1D	- (NET X5 function) ^{*1}	The function assigned to Pr.189 is activated.

- *1 Signal names are initial values. Using **Pr.180 to Pr.189**, you can change input signal functions. Note that some of signals do not accept a command from the network according to the **Pr.338** and **Pr.339** settings. For example, RYB reset (terminal RES function) cannot be controlled via network.
For details of **Pr.180 to Pr.189**, **Pr.338**, and **Pr.339**, refer to the FR-E800 Instruction Manual (Function).
- *2 The signals are fixed. They cannot be changed using parameters.
- *3 While "1" is set in the frequency setting command (RYD), the set frequency (RWw1) is always applied.
- *4 If "1" is set in these registers at the same time while **Pr.544** = "0", only one of these is executed.
- *5 Refer to [page 44](#) for operation conditions of inverter reset.
- *6 Torque control cannot be performed with a PM motor.

7.1.2 Input signals (inverter (FR-A8NC) to master module)

The input signals to the master module are indicated. (Output signals from inverter)

Device no.	Signal	Description
RX0	Forward running	0: Other than forward running (during stop or reverse rotation) 1: Forward running
RX1	Reverse running	0: Other than reverse running (during stop or forward rotation) 1: Reverse running
RX2	Running (terminal RUN function) ^{*1}	The function assigned to Pr.190 is activated.
RX3	Up to frequency (SU signal) ^{*3}	1: The output frequency reaches the set frequency.
RX4	Overload alarm (OL signal) ^{*3}	1: Overload warning activated
RX5	- (NET Y1 function) ^{*1}	The function assigned to Pr.193 is activated.
RX6	Frequency detection (terminal FU function) ^{*1}	The function assigned to Pr.191 is activated.
RX7	Fault (terminal ABC function) ^{*1}	The function assigned to Pr.192 is activated.
RX8	- (NET Y2 function) ^{*1}	The function assigned to Pr.194 is activated.
RX9	- (DO0 function) ^{*2}	Functions assigned to Pr.313 to Pr.315 are activated.
RXA	- (DO1 function) ^{*2}	
RXB	- (DO2 function) ^{*2}	
RXC	Monitoring	After "1" is set in the monitor command (RYC), and the monitored value is set in the remote register Rwr0, 1, 4 to 7, "1" is set in this signal. When "0" is set in the monitor command (RYC), "0" is set in this signal.
RXD	Frequency setting completion/torque command setting completion (RAM)	After "1" is set in the frequency setting command/torque command (RYD) and the frequency setting command/torque command is written to the inverter RAM, "1" is set in this signal. When "0" is set in the frequency setting command/torque command (RYD), "0" is set in this signal. Under Real sensorless vector control or PM sensorless vector control, the following value is also written to RAM and EEPROM at the same time. • During torque control: Torque command value • During speed control / position control: Torque limit value

Device no.	Signal	Description
RXE	Frequency setting completion/torque command setting completion (RAM, EEPROM)	After "1" is set in the frequency setting command/torque command (RYE) and the frequency setting command/torque command is written to the inverter RAM and EEPROM, "1" is set in this signal. When "0" is set in the frequency setting command/torque command (RYE), "0" is set in this signal. Under Real sensorless vector control or PM sensorless vector control, the following value is also written to RAM and EEPROM at the same time. • During torque control: Torque command value • During speed control / position control: Torque limit value
RXF	Instruction code execution completion	After "1" is set in the instruction code execution request (RYF) and the processes corresponding to the instruction codes (RWw2, 10, 12, 14, 16 and 18) are executed, "1" is set in this signal. When "0" is set in the instruction code execution request (RYF), "0" is set in this signal.
RX16	- (NET Y3 function) ^{*1}	The function assigned to Pr.195 is activated.
RX17	- (NET Y4 function) ^{*1}	The function assigned to Pr.196 is activated.
RX1A	Error status flag	When an inverter error occurs (protective function is activated), "1" is set in this signal.
RX1B	Remote station ready	When the inverter goes into the ready status upon completion of initial setting after power-on or hardware reset, "1" is set in this signal. When an inverter error occurs (protective function is activated), "0" is set in this signal. The signal is used as an interlock signal during the write to/read from the master module.
RX1C	In-position ^{*3}	1: In-position
RX1D	During position command operation ^{*3}	1: During position command operation
RX1E	Home position return completed ^{*3}	1: Home position return completed
RX1F	Home position return failure ^{*3}	1: Home position return error warning activated

*1 Signal names are initial values. Using **Pr.190 to Pr.196**, you can change output signal functions.

For the details of **Pr.190 to Pr.196**, refer to the FR-E800 Instruction Manual (Function).

*2 Signals are not assigned in the initial setting. Use **Pr.313 to Pr.315** to assign signals to the devices RX9 to RXB.

For details of **Pr.313 to Pr.315**, refer to the FR-E800 Instruction Manual (Function).

*3 The signals are fixed. They cannot be changed using parameters.

7.2 Details of remote register

7.2.1 Remote register (master module to inverter (FR-A8NC))

◆ Remote register definition

Device no.	Signal	Description
RWw0	Monitor code 1, 2	Set the monitor code to be referenced (Refer to page 78). When "1" is set in RYC, data of specified monitored items will be stored in RWr0, RWr1.
RWw1	Set frequency ^{*1}	Specify the set frequency or speed (machine speed). At this time, whether to write to RAM or EEPROM is decided with the RYD and RYE settings. After setting the set frequency in this register, set "1" in RYD or RYE to write the frequency. After writing of frequency is completed, "1" is set in RXD or RXE in response to the input command. The setting range is 0 to 590.00 Hz (0.01 Hz increments). Write "59000" when setting 590.00 Hz.
	Torque command value	When Pr.544 CC-Link extended setting = "0, 1, or 12" and Pr.804 Torque command source selection = "3 or 5" under Real sensorless vector control, torque command values are specified. The value is written to the inverter either by RYD or RYE. Pr.805 Torque command value (RAM) and Pr.806 Torque command value (RAM, EEPROM) are also updated at the same time. The setting range and setting increments depend on the Pr.804 setting. (Refer to page 79 .)
RWw2	Link parameter extended setting/ Instruction code	Set the instruction code for execution of operation mode rewrite, Pr.read/write, error reference, error clear, etc. (Refer to page 74) Set "1" in RYF to execute the corresponding instruction after completing the register setting. "1" is set in RXF after completing the execution of the instruction. When a value other than "0 (100)" is set in Pr.544 , upper eight bits are link parameter extended setting. Example) When reading Pr.160 , instruction code is H0200.
RWw3	Write data	Set the data specified by the RWw2 instruction code. (When required) Set "1" in RYF after setting RWw2 and this register. Set "0" when the write code is not required.
RWw4	Monitor code 3	Set the monitor code to be monitored. By setting "1" in RYC after setting, the specified monitored data is stored in RWr4 to 7.
RWw5	Monitor code 4	
RWw6	Monitor code 5	
RWw7	Monitor code 6	

Device no.	Signal	Description
RWw8	Fault record No.	Set how many fault records in past to be read. Fault records can be read back to the eighth latest fault (lower 8 bits is H00). Upper 8 bits: H00 (latest fault) to H09 (eighth latest fault) When HOA to HFF is set to the upper 8 bits, the fault record becomes an undetermined value.
RWw9	PID set point ^{*2}	Set the PID set point Setting range: "0 to 100.00%"
RWwA	PID measured value ^{*2}	Set the PID measured value Setting range: "0 to 100.00%"
RWwB	PID deviation ^{*2}	Set the PID deviation. Setting range: "-100.00% to 100.00%"
RWwC	Torque command value	When Pr.544 = "14 or 18" and Pr.804 = "3 or 5" during torque control (Real sensorless vector control), torque command values can be specified. The value is written to the inverter by RYD or RYE. Pr.805 and Pr.806 are also updated at the same time. The setting range and the setting increment depend on the Pr.804 setting. If the data outside the range is set, the previous setting is retained.
	Torque limit value	Set Pr.544 = "14 or 18", Pr.804 = "3 or 5", and Pr.810 Torque limit input method selection = "2" to specify the torque limit value during speed control or position control under Real sensorless vector control or PM sensorless vector control. The value is written to the inverter by RYD or RYE. Pr.805 and Pr.806 are also updated at the same time. The setting range and the setting increment depend on the Pr.804 setting (absolute value). If the data outside the range is set, the previous setting is retained.
RWw10, RWw12, RWw14, RWw16, RWw18	Link parameter extended setting/ Instruction code	Set the instruction code (Refer to page 74.) for execution of operation mode rewrite, Pr.read/write, error reference, error clear, etc. The instructions are executed in the following order by setting "1" in RYF after completing the register setting: RWw2, 10, 12, 14, 16, then 18. After completing the execution up to RWw18, "1" is set in RXF. Set HFFFF to disable an instruction by RWw10 to 18. (RWw2 is always executed.) The first 8 bits are link parameter extended setting. Example) When reading Pr.160 , instruction code is H0200.
RWw11, RWw13, RWw15, RWw17, RWw19	Write data	Set the data specified by the instruction code of RWw10, 12, 14, 16, and 18. (when required) RWw10 and 11, 12 and 13, 14 and 15, 16 and 17, and 18 and 19 correspond each other. Set "1" in RYF after setting the instruction codes (RWw10, 12, 14, 16, and 18) and the corresponding register. Set "0" when the write code is not required.

- *1 When **Pr.541 Frequency command sign selection** = 1, the setting value has either + or -. When the setting value is negative, the command is inverted from starting command.
Setting range: -327.68 Hz to 327.67 Hz (-327.68 to 327.67) 0.01 Hz increments
For details refer to [page 48](#).
- *2 Validity depends on the **Pr.128**, **Pr.609**, and **Pr.610** settings. For details, refer to the FR-E800 Instruction Manual (Function). If the data outside the range is set, the previous setting is retained.

7.2.2 Remote register (inverter (FR-A8NC) to master module)

◆ Remote register definition

Device no.	Signal	Description
RWr0	First monitor value	When "1" is set in RYC, the specified monitored data is set to the lower 8 bits of the monitor code (RWw0).
RWr1	Second monitor value (Output frequency)	When "0" is set to the upper 8 bits of the monitor code (RWw0), the current output frequency is always set. When a value other than "0" is set to the upper 8 bits of the monitor code (RWw0) while "1" is set in RYC, the monitor data specified by the upper 8 bits of the monitor code (RWw0) is set.
RWr2	Reply code (when Pr.544 = 0)	When "1" is set in RYD or RYE, the reply code for the frequency setting command is set. When "1" is set in RYF, the reply code corresponding to the instruction code RWw2 is set. The value "0" is set for a normal reply and any digit other than "0" is set for data fault, mode error, etc. (Refer to page 71.)
	Reply code 1 (when Pr.544 ≠ 0)	Lower 8 bits of RWr2 When "1" is set in RYD or RYE, the reply code for the frequency setting command (torque command / torque limit) is set. (Refer to page 71.)
	Reply code 2 (when Pr.544 ≠ 0)	Upper 8 bits of RWr2 When "1" is set in RYF, the reply code corresponding to the instruction code RWw2 is set. (Refer to page 71.)
RWr3	Read data	For a normal reply, the reply data to the instruction specified by the instruction code is set.
RWr4	Third monitor value	When "1" is set in RYC, the monitored data specified by the monitor code (RWw4 to 7) is saved.
RWr5	Fourth monitor value	
RWr6	Fifth monitor value	
RWr7	Sixth monitor value	
RWr8	Fault record (fault data)	
RWr9	Fault record (output frequency)	Output frequency of the fault record No. specified in RWw8 is stored.
RWrA	Fault record (output current)	Output current of the fault record No. specified in RWw8 is stored.
RWrB	Fault record (output voltage)	Output voltage of the fault record No. specified in RWw8 is stored.

Device no.	Signal	Description
RWrC	Fault record (energization time)	Energization time of the fault record No. specified in RWw8 is stored.
RWr10 to RWr19	Reply code	When "1" is set in RYF, the reply codes corresponding to the instruction code RWw10, 12, 14, 16, and 18 are set. The value "0" is set for a normal reply and other than "0" is set for data fault, mode error, etc. (Refer to page 71 .)
	Read data	For a normal reply, the reply data to the instruction specified by the instruction code is set.

◆ Reply code definition

The reply to the instruction execution is set to RWr2, 10, 12, 14, 16, 18.

When executing the frequency setting (RYD, RYE) or instruction code execution (RYF), check the reply code (RWr2) in the remote register after execution.

	Data	Item	Alarm definition	Remarks
Reply code	H0000	Normal	No error (normal completion of instruction code execution)	<ul style="list-style-type: none"> • Reply code to RWr2 when Pr.544 = 0 • Reply code to RWw10, 12, 14, 16, and 18 when Pr.544 = 18
	H0001	Write mode error	Parameter write was attempted during operation other than a stop in the network operation mode.	
	H0002	Parameter selection error	Unregistered code number was set.	
	H0003	Setting range error	Set data is outside the permissible data range.	

	Data	Item	Alarm definition	Remarks
Reply code 1 ^{*1}	H00	Normal	No error (normal completion of instruction code execution)	Reply code to RWr2 when Pr.544 ≠ 0
	H01	Write mode error ^{*2}	Parameter write was attempted during operation other than a stop in the network operation mode.	
	H03	Frequency command / torque command / torque limit setting range error	The value outside the range is set.	
Reply code 2	H00	Normal	No error (normal completion of instruction code execution)	
	H01	Write mode error	Parameter write was attempted during operation other than a stop in the network operation mode.	
	H02	Parameter selection error	Unregistered code number was set.	
	H03	Setting range error	Set data is outside the permissible data range.	

- *1 The contents of the reply code 1 are changed when torque commands are given or the torque is limited (when **Pr.544** = "14 or 18").

The upper 4 bits of the reply code 1 are used as the reply code to the torque command / torque limit, and the lower 4 bits are used as the reply code to the frequency command.

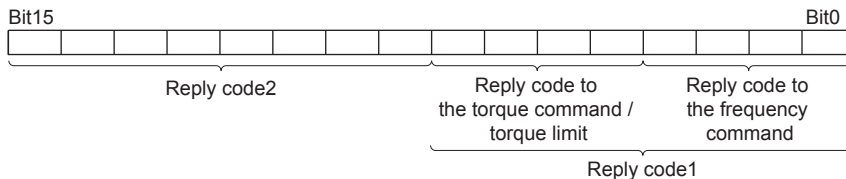

Example) The error code is H0030 when the torque command value is outside the setting range.

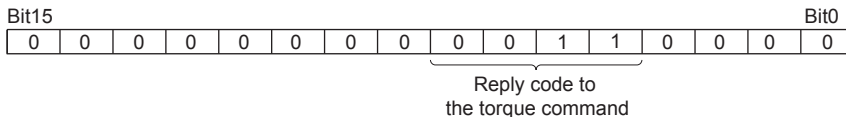

- *2 The data is valid only when the frequency setting command is given.

7.2.3 Instruction codes

◆ Instruction code definition

Set the instruction code using a remote register (RWw) (Refer to [page 67.](#))

The definition read by the instruction code is stored in the remote register (RWr). (Refer to [page 70.](#))

Item		Read/ write	Instruction code	Description
Operation mode		Read	H7B	H0000: Network operation mode H0001: External operation mode, External JOG operation mode H0002: PU operation mode, External/PU combined operation mode 1 and 2, PUJOG operation mode
		Write	HFB	H0000: Network operation mode H0001: External operation mode H0002: PU operation mode (Pr.79 = "6")
Monitor	Output frequency/ speed ^{*1}	Read	H6F	H0000 to HFFFF Output frequency: Increments 0.01 Hz
	Output current	Read	H70	H0000 to HFFFF Output current (hexadecimal): Increments 0.01 A
	Output voltage	Read	H71	H0000 to HFFFF Output voltage (hexadecimal): Increments 0.1 V
	Special monitor	Read	H72	H0000 to HFFFF: Check the data of the monitor selected by the instruction code HF3.
	Special monitor selection No.	Read	H73	H01 to HFF: Monitor selection data Refer to monitor code. (Refer to page 78.)
Write		HF3 ^{*2}		

Item		Read/write	Instruction code	Description																				
Monitor	Fault record	Read	H74 to H78	H0000 to HFFFF: Two fault records per code.																				
				H74	<table border="1"> <tr> <td style="text-align: center;">b15</td> <td style="text-align: center;">b8</td> <td style="text-align: center;">b7</td> <td style="text-align: center;">b0</td> </tr> <tr> <td colspan="2">Second latest fault</td> <td colspan="2">Latest fault</td> </tr> </table>	b15	b8	b7	b0	Second latest fault		Latest fault												
				b15	b8	b7	b0																	
				Second latest fault		Latest fault																		
				H75	<table border="1"> <tr> <td colspan="2">Fourth latest fault</td> <td colspan="2">Third latest fault</td> </tr> </table>	Fourth latest fault		Third latest fault																
Fourth latest fault		Third latest fault																						
H76	<table border="1"> <tr> <td colspan="2">Sixth latest fault</td> <td colspan="2">Fifth latest fault</td> </tr> </table>	Sixth latest fault		Fifth latest fault																				
Sixth latest fault		Fifth latest fault																						
H77	<table border="1"> <tr> <td colspan="2">Eighth latest fault</td> <td colspan="2">Seventh latest fault</td> </tr> </table>	Eighth latest fault		Seventh latest fault																				
Eighth latest fault		Seventh latest fault																						
H78	<table border="1"> <tr> <td colspan="2">Tenth latest fault</td> <td colspan="2">Ninth latest fault</td> </tr> </table>	Tenth latest fault		Ninth latest fault																				
Tenth latest fault		Ninth latest fault																						
				<p>For instruction code H74, read data H30A0</p> <table border="1"> <tr> <td style="text-align: center;">b15</td> <td style="text-align: center;">b8</td> <td style="text-align: center;">b7</td> <td style="text-align: center;">b0</td> </tr> <tr> <td>0</td><td>0</td><td>1</td><td>1</td><td>0</td><td>0</td><td>0</td><td>0</td><td>1</td><td>0</td><td>1</td><td>0</td><td>0</td><td>0</td><td>0</td><td>0</td> </tr> </table> <p>Second latest fault (H30) Latest fault (HA0)</p> <p style="text-align: center;">↓</p> <p>Second latest fault THT Latest fault OPT</p>	b15	b8	b7	b0	0	0	1	1	0	0	0	0	1	0	1	0	0	0	0	0
b15	b8	b7	b0																					
0	0	1	1	0	0	0	0	1	0	1	0	0	0	0	0									
				For the data codes or details of fault records, refer to the FR-E800 Instruction Manual (Maintenance).																				
Set frequency (RAM)		Read	H6D	<p>Read the set frequency/speed from the RAM or EEPROM. H0000 to HE678: Set frequency in 0.01 Hz increments</p> <ul style="list-style-type: none"> When Pr.544 = "0, 1, or 12" and Pr.804 = "3 or 5" during torque control under Real sensorless vector control, torque command values are read. The setting range depends on Pr.804. 																				
Set frequency (EEPROM)			H6E																					
Set frequency (RAM) ^{*3}		Write	HED	<p>Write the set frequency/speed into the RAM or EEPROM. H0000 to HE678 (0 to 590.00 Hz): frequency in 0.01 Hz increments</p> <ul style="list-style-type: none"> To change the set frequency consecutively, write data to the inverter RAM. (Instruction code: HED) When Pr.544 = "0, 1, or 12" and Pr.804 = "3 or 5" during torque control under Real sensorless vector control, torque command values are read. The setting range depends on Pr.804. 																				
Set frequency (RAM and EEPROM) ^{*3}		Write	HEE																					

Item	Read/write	Instruction code	Description
Parameter	Read	H00 to H63	<ul style="list-style-type: none"> Refer to the instruction codes in the FR-E800 Instruction Manual (Function) to read/write parameters as required. Write to Pr.77 and Pr.79 is disabled. When setting Pr.100 and later, set link parameter extended setting. Set 65520 (HFFF0) as a parameter value "8888" and 65535 (HFFFF) as "9999". When changing the parameter values frequently, set "1" in Pr.342 to write them to the RAM. For details, refer to the FR-E800 Instruction Manual (Communication).
	Write	H80 to HE3	
Fault record batch clear	Write	HF4	H9696: Clears the fault records as a batch.
All parameter clear	Write	HFC	<p>All parameters return to the initial values. Whether to clear communication parameters or not can be selected according to data.</p> <ul style="list-style-type: none"> Parameter clear H9696: Communication parameters are cleared. H5A5A^{*4}: Communication parameters are not cleared. All parameter clear H9966: Communication parameters are cleared. H55AA^{*4}: Communication parameters are not cleared. <p>For the details of whether or not to clear parameters, refer to the FR-E800 Instruction Manual (Function).</p> <p>When clear is executed for H9696 or H9966, communication-related parameter settings also return to the initial values. When resuming operation, set the parameters again. Executing clear will clear the instruction code HEC, HF3, and HFF settings.</p>
Inverter reset	Write	HFD	H9696: Resets the inverter.
Link parameter extended setting ^{*5}	Read	H7F	<p>Parameter settings are changed according to the instruction code settings.</p> <p>For details of the settings, refer to instruction code list in the FR-E800 Instruction Manual (Function).</p>
	Write	HFF	

Item	Read/write	Instruction code	Description
Second parameter changing ^{*6}	Read	H6C	Read or write of bias and gain parameters. For the details of setting values, refer to the calibration parameter list of the FR-E800 Instruction Manual (Function). H00: Frequency ^{*7} H01: Analog value set in parameters H02: Analog value input from the terminal
	Write	HEC	

- *1 When "100" is set in **Pr.52 Operation panel main monitor selection**, frequency setting is monitored during a stop and output frequency is monitored during running.
- *2 Write data is in hexadecimal, and only last two digits are valid. (The upper two digits are ignored.)
- *3 Setting from the remote register (RWw1) is also available.
- *4 Turning OFF the power supply while clearing parameters with H5A5A or H55AA sets back the communication parameter settings to the initial settings.
- *5 Setting is valid only when **Pr.544** = "0". When **Pr.544** ≠ "0", set using RWw2 or RWw10, 12, 14, 16, or 18. (Refer to [page 67](#))
- *6 Reading or writing is available when the link parameter extended setting = "1 or 9".
- *7 Gain frequencies can be written using **Pr.125** (instruction code H99) and **Pr.126** (instruction code H9A) also.

NOTE

- When the 32-bit parameter setting or monitor description are read and the read value exceeds HFFFF, the reply data will be HFFFF.

7.2.4 Monitor codes

Information about the inverter can be monitored by setting the special monitor selection No. of the instruction code and monitor code using the remote registers, RWw0 and RWw4 to 7.

- For the monitor code (RWw0), select the first monitor description (RWr0) from the lower 8 bits and the second monitor description (RWr1) from the upper 8 bits.

Ex.

When output current is selected for the first monitor (RWr0) and running speed is selected for the second monitor (RWr1) → monitor code (RWw0) is H0602

- When **Pr.544** = "12, 14, or 18", descriptions of monitor codes 3 (RWw4) to 6 (RWw7) can be selected.

Monitor code	Second monitor description (the first 8 bits)	First, third to sixth monitor description (the last 8 bits)	Increments
H00	Output frequency	No monitoring (monitor value is 0)	0.01 Hz
H01	Output frequency		0.01 Hz
H02	Output current		0.01 A
H03	Output voltage		0.1 V
.	.		.
.	.		.
.	.		.



NOTE

- The monitor codes (monitored items) after H01 are the same as those of the RS-485 communication dedicated monitor. For the details of the monitor codes or monitor items, refer to the monitor display section in the FR-E800 Instruction Manual (Function).
- When the remote registers RWw0 and RWw4 to 7 are used for monitoring, H00 (output frequency), H01 (output frequency), and H05 (set frequency) always indicate the frequency regardless of the settings of **Pr.37**, and **Pr.53**.

7.3 Torque command / torque limit by CC-Link communication

Torque commands can be given or the torque can be limited by CC-Link communication under Real sensorless vector control, or PM sensorless vector control. The value is used to limit the torque during speed control or position control, and to give a torque command during torque control. To limit the torque, **Pr.810 Torque limit input method selection = "2"**. The torque command / torque limit setting method can be selected using **Pr.804 Torque command source selection** . (Torque control cannot be performed with a PM motor.)

Pr.	Name	Initial value	Setting range	Description
804	Torque command source selection	0	0	Torque command by terminal 4 analog input
			1	Torque command / torque limit by CC-Link communication (FR-A8NC) • Torque command / torque limit (-400% to 400%) by the parameter setting (Pr.805 or Pr.806) ^{*1*2}
			3	Torque command / torque limit by CC-Link communication (FR-A8NC) • Torque command / torque limit (-400% to 400%) by the parameter setting (Pr.805 or Pr.806) ^{*1*2} • Setting is available using the remote register RWW1 or RWWC. (-400% to 400%) ^{*2}
			4	Torque command by 16 bit digital input (FR-A8AX) ^{*3}
			5	Torque command / torque limit by CC-Link communication (FR-A8NC) • Torque command / torque limit (-327.68% to 327.67%) by the parameter setting (Pr.805 or Pr.806) ^{*1*2} • Setting is available using the remote register RWW1 or RWWC. (-327.68% to 327.67%) ^{*2}
			6	Torque command / torque limit by CC-Link communication (FR-A8NC) • Torque command / torque limit (-327.68% to 327.67%) by the parameter setting (Pr.805 or Pr.806) ^{*1*2}
810	Torque limit input method selection	0	0	Internal torque limit (torque limited by parameter settings)
			1	External torque limit (torque limited by terminals 4)
			2	Internal torque limit 2 (torque limited via CC-Link communication (FR-A8NC))

*1 Can also be set from operation panel.

*2 When a negative value is set as the torque limit, the torque is limited by the absolute value.

*3 Available only when the FR-A8AX is installed. For details, refer to the FR-A8AX E kit Instruction Manual.

◆ **List of I/O devices whose function is changed according to the parameter settings and the control method**

Pr.544 setting	I/O device	V/F control / Advanced magnetic flux vector control	Real sensorless vector control / PM sensorless vector control	
			Speed control / position control	Torque control ^{*3}
-	RYD	Frequency setting command (RAM)	Frequency setting / torque limit command (RAM)	Torque command (RAM)
-	RYE	Frequency setting command (RAM, EEPROM)	Frequency setting / torque limit command (RAM, EEPROM)	Torque command (RAM, EEPROM)
-	RXD	Frequency setting completion (RAM)	Frequency setting / torque limit completion (RAM)	Torque command completion (RAM)
-	RXE	Frequency setting completion (RAM, EEPROM)	Frequency setting / torque limit completion (RAM, EEPROM)	Torque command completion (RAM, EEPROM)
0, 1, 12	RWw1	Set frequency	Set frequency	Torque command ^{*1}
14, 18				Set frequency
0, 1, 12	RWwC	-	-	-
14, 18			Torque limit ^{*1*2}	Torque command ^{*1}

*1 Pr.804 ="3 or 5" must be set.

*2 Pr.810 = "2" must be set.

*3 Torque control cannot be performed with a PM motor.

◆ Torque command setting method and parameter for speed limit

Pr.804 setting	Pr.544 setting	Torque command setting method (Any method below can be chosen)	Parameter for speed limit
3, 5	0, 1, 12	<ul style="list-style-type: none"> Set the torque command value in RWwn+1, and "1" in RYD or RYE. Set the instruction code HED or HEE in RWwn+2, the torque command value in RWwn+3, and "1" in RYF. (Torque command value can be read by the instruction code H6D and H6E.) Set H08 in the link parameter extended setting, the instruction code H85 or H86 in RWwn+2, the torque command value in RWwn+3, and "1" in RYF (written to Pr.805 or Pr.806). 	Pr.808, Pr.809
	14, 18	<ul style="list-style-type: none"> Set the torque command value in RWwn+C, and "1" in RYD or RYE. Set H08 in the link parameter extended setting, the instruction code H85 or H86 in RWwn+2, the torque command value in RWwn+3, and "1" in RYF (written to Pr.805 or Pr.806). 	
1, 6	0, 1, 12, 14, 18	Set H08 in the link parameter extended setting, the instruction code H85 or H86 in RWwn+2, the torque command value in RWwn+3, and "1" in RYF (written to Pr.805 or Pr.806).	Pr.807
0, 4	-	Torque command from CC-Link communication is disabled.	

◆ Torque limit setting method

Pr.804 setting	Pr.810 setting	Pr.544 setting	Torque limit setting method (Any method below can be chosen)
3, 5	2	14, 18	<ul style="list-style-type: none"> Set the torque limit value in RWwn+C, and "1" in RYD or RYE. Set H08 in the link parameter extended setting, the instruction code H85 or H86 in RWwn+2, the torque limit value in RWwn+3, and "1" in RYF (written to Pr.805 or Pr.806).
1, 6		0, 1, 12, 14, 18	Set H08 in the link parameter extended setting, the instruction code H85 or H86 in RWwn+2, the torque limit value in RWwn+3, and "1" in RYF (written to Pr.805 or Pr.806).

◆ Relationship between the Pr.804 setting, the setting range, and the actual torque command / torque limit (when setting is made from CC-Link communication)

Pr.804 setting	Setting range	Actual torque command	Actual torque limit
1, 3	600 to 1400 (1% increments)*1	-400 to 400%	0 to 400%
5, 6	-32768 to 32767 (two's complement)*1	-327.68 to 327.67%	0 to 327.67%

*1 The torque limit setting is defined as an absolute value.

8 PROGRAMMING EXAMPLES

This chapter provides programming examples which control the inverter with sequence programs.

Item	Program example	Refer to page
Reading the inverter status	Reading the inverter status from the buffer memory of the master station	85
Setting the operation mode	Selecting the network operation mode	86
Setting the operation commands	Commanding the forward rotation and middle speed signals	87
Setting the monitoring function	Monitoring the output frequency	88
Reading a parameter value	Reading the value of Pr.7 Acceleration time	89
Writing a parameter value	Setting "3.0 s" in Pr.7 Acceleration time	90
Setting the running frequency (running speed)	Setting to 50.00 Hz	91
Reading the fault records	Reading the inverter faults	93
Inverter reset	Perform inverter reset at an inverter alarm occurrence.	94

◆ System configuration for programming example

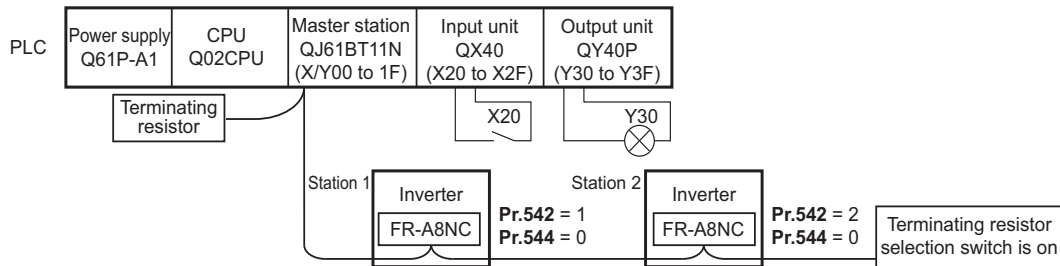

◆ Network parameter setting of the master station

Network parameters are set as below.

Item		Setting conditions
Start I/O No.		0000
Operation settings	Data link alarm station setting	Input clear
	Setting at CPU stop	Refresh
Type		Master
Mode		Remote net Ver.1 mode
All connect count		2
Remote input (RX)		X1000
Remote output (RY)		Y1000
Remote register (RWr)		W0

Item		Setting conditions
Remote register (RWw)		W100
Special relay (SB)		SB0
Special resistor (SW)		SW0
Retry count		3
Automatic reconnection station count		1
CPU down select		Stop
Scan mode settings		Asynchronous
Station information	Station type	Remote device station

- The relation between the device of the programmable controller CPU and remote I/O (RX, RY) of the remote device station is as follows: The devices used actually are indicated in shaded regions.

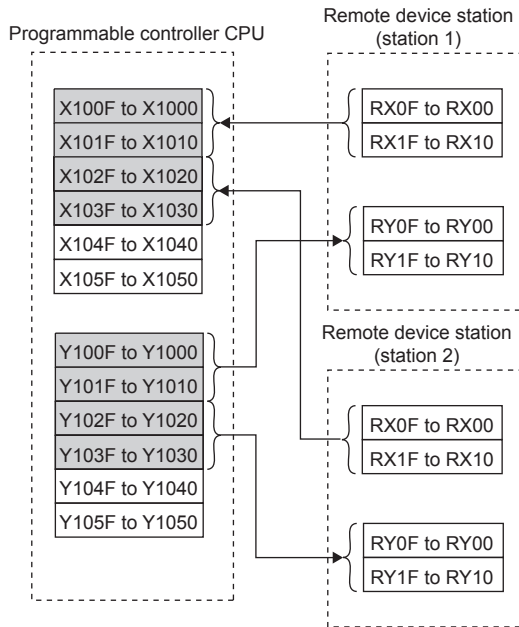

- The relation between the device of the programmable controller CPU and remote register (RWw, RWr) of the remote device station is as follows: The devices used actually are indicated in shaded regions.

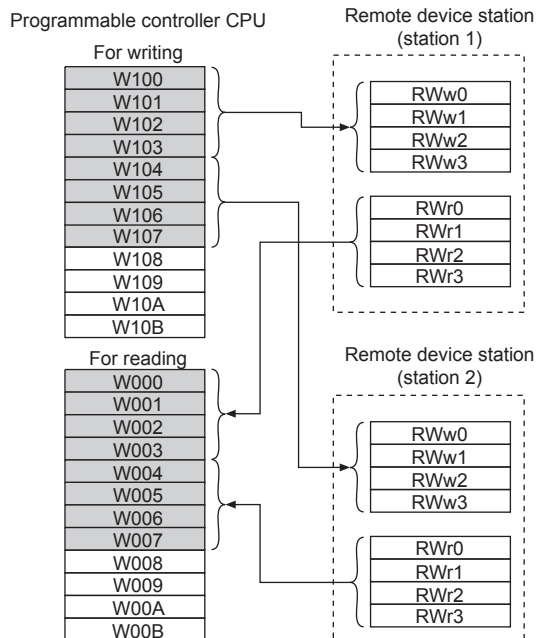

8.1 Program example for reading the inverter status

The following program turns on Y00 of the output unit when station 1 inverter is running

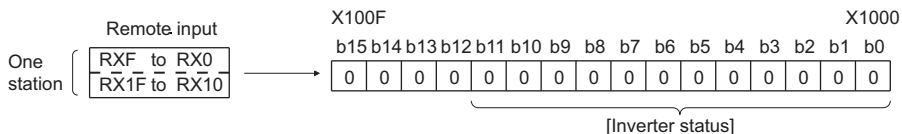
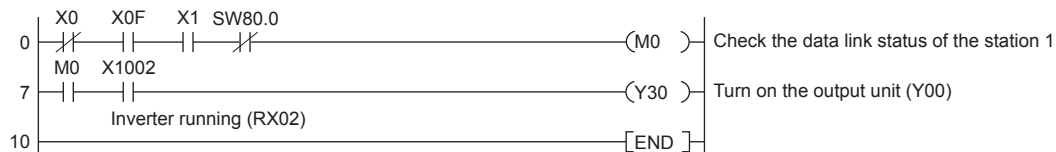

Inverter status

- b0: Forward running*2
- b1: Reverse running*2
- b2: Running (terminal RUN function)*1
- b3: Up to frequency*2
- b4: Overload alarm*2
- b5: No function (terminal NET Y1 function)*1
- b6: Frequency detection (terminal FU function)*1
- b7: Fault (terminal ABC function)*1
- b8: No function (terminal NET Y2 function)*1
- b9: No function (DO0)*1
- b10: No function (DO1)*1
- b11: No function (DO2)*1

*1 These signals are initial values. You can change output signals using **Pr.190 to Pr.196, Pr.313 to Pr.315 (output terminal function selection)**.

*2 The signals are fixed. They cannot be changed using parameters.

8.2 Program example for setting the operation mode

The following explains a program to write various data to the inverter.

The following explains a program to change the operation mode of station 1 inverter to network operation.

- Operation mode write code: HFB (hexadecimal)
- Network operation set data: H0000 (hexadecimal) (Refer to [page 74](#))
- The reply code at the time of instruction code execution is set to D2. (Refer to [page 71](#))

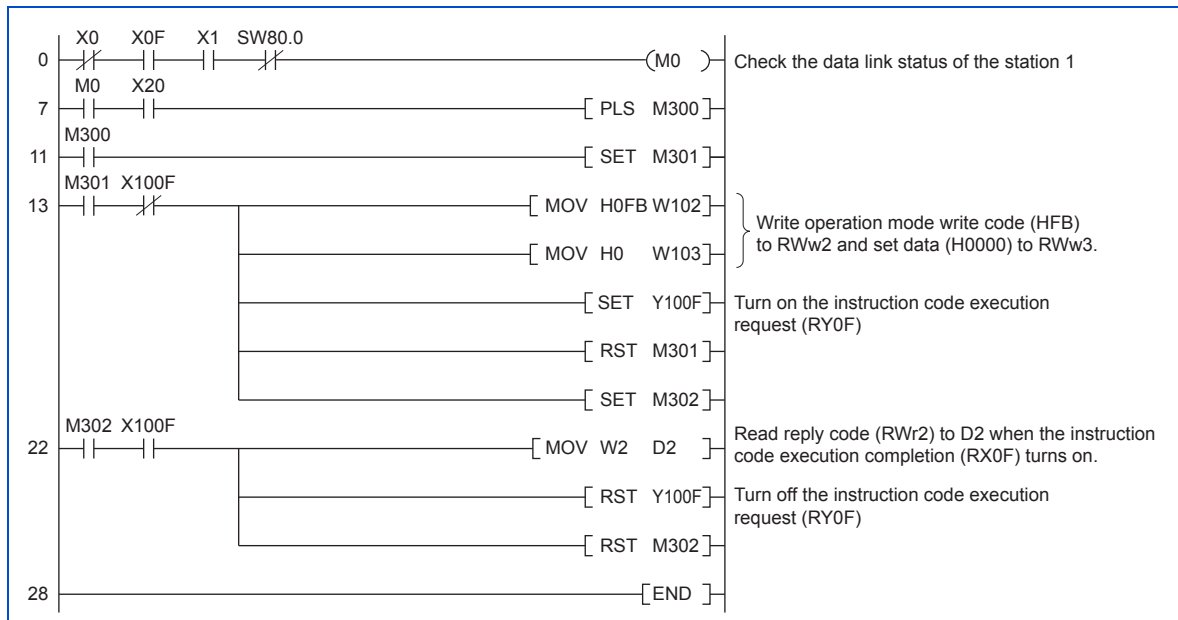

8.3 Program example for setting the operation commands

The following program gives a forward command and middle speed command to station 1 inverter

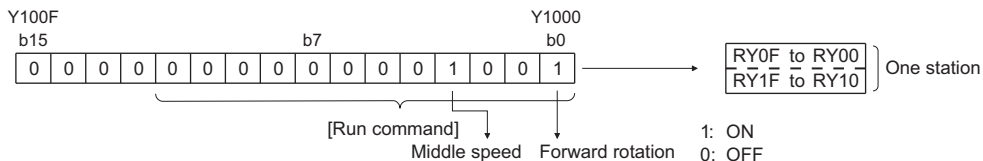
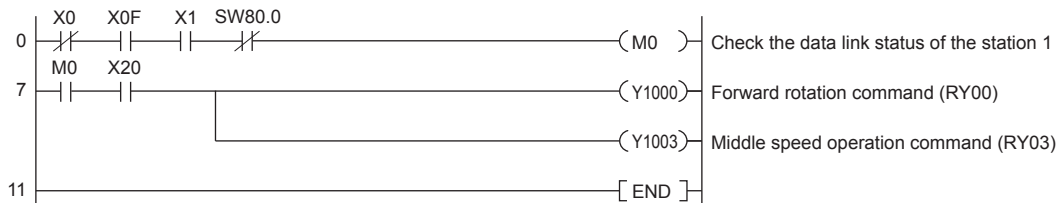

Run command

b0: Forward rotation command*2

b1: Reverse rotation command*2

b2: High-speed operation command (terminal RH function)*1

b3: Middle-speed operation command (terminal RM function)*1

b4: Low-speed operation command (terminal RL function)*1

b5: Jog operation selection 2*2

b6: Second function selection*2

b7: Current input selection (AU)*1

b8: No function (terminal NET X1 function)*1

b9: Output stop (terminal MRS function)*1

b10: No function (terminal NET X2 function)*1

b11: Inverter reset (terminal RES function)*1

*1 These signals are initial values. You can change input signals using **Pr.180 to Pr.189 (input terminal function selection)**. Note that some of the signals do not receive a command from the programmable controller depending on the setting. (For details, refer to the FR-E800 Instruction Manual (Function).)

*2 The signals are fixed. They cannot be changed using parameters.

8.4 Program example for monitoring the output frequency

The following explains a program to read monitor functions of the inverter.

The following program reads the output frequency of station 1 inverter to D1.

Output frequency read code: H0001 (hexadecimal)

Refer to [page 78](#) for the monitor codes.

(Example) The output frequency of 60 Hz is indicated as H1770 (6000).

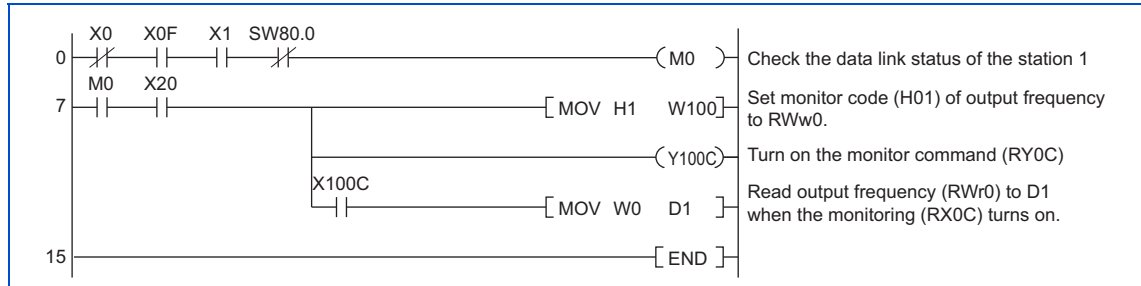

8.5 Program example for parameter reading

The following program reads **Pr.7 Acceleration time** of station 1 inverter to D1.

- **Pr.7 Acceleration time** reading instruction code: H07 (hexadecimal)
- For the instruction codes of parameters, refer to the FR-E800 Instruction Manual (Function).
- The reply code at the time of instruction code execution is set to D2. (Refer to [page 71](#))

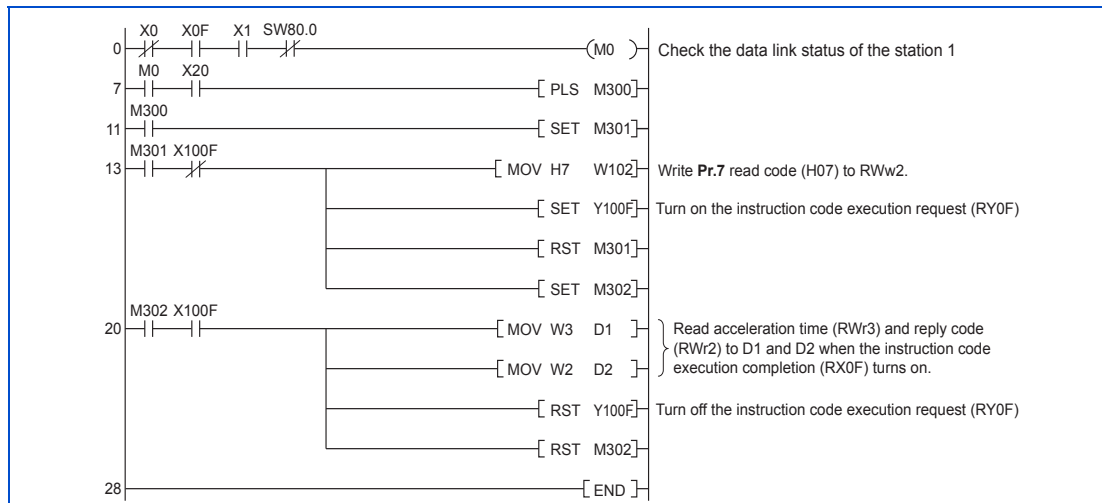

NOTE

- For parameters having numbers 100 and later, change their link parameter extended settings (set them to other than H00). For details of the settings, refer to the instruction code list in the FR-E800 Instruction Manual (Function).

8.6 Program example for parameter writing

The following program changes the setting of **Pr.7 Acceleration time** of station 1 inverter to 3.0 s.

- Acceleration time writing instruction code: H87 (hexadecimal)
- Acceleration time set data: K30 (decimal)

For the instruction codes of parameters, refer to the FR-E800 Instruction Manual (Function).

The reply code at the time of instruction code execution is set to D2. (Refer to [page 71](#))

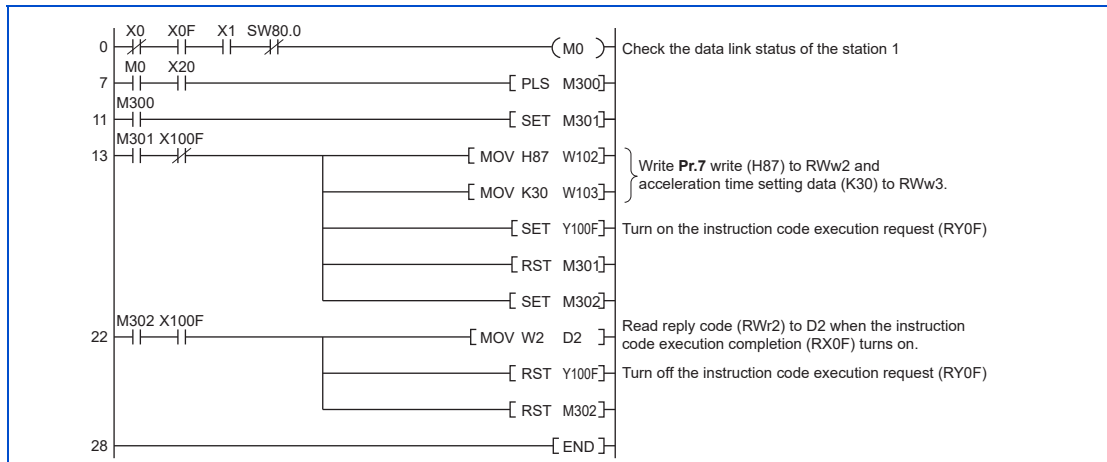

NOTE

- For parameters having numbers 100 and later, change their link parameter extended settings (set them to other than H00). For details of the settings, refer to the instruction code list in the FR-E800 Instruction Manual (Function).
- For other functions, refer to the instruction codes (Refer to [page 74](#)).

8.7 Program example for setting the running frequency

- The following program example changes the running frequency of station 1 inverter to 50.00 Hz

Set frequency: K5000 decimal

The reply code at the time of instruction code execution is set to D2. (Refer to [page 71](#))

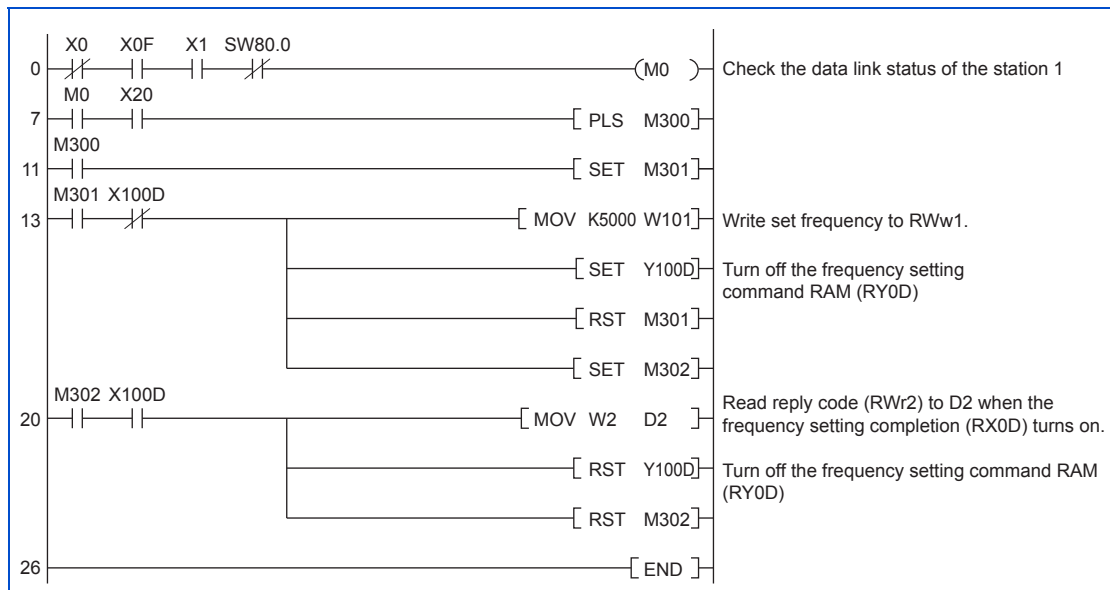

- To continuously change the running frequency from the programmable controller

When the frequency (speed) setting completion (example: X100D) switches on, make sure that the reply code in the remote register is H0000 and change the set data (example: W101) continuously.

- Program example for writing data to EEPROM

Modify the program on [page 91](#) as follows:

Frequency setting command Y100D → Y100E

Frequency setting completion X100D → X100E

<Timing chart when writing to RAM>

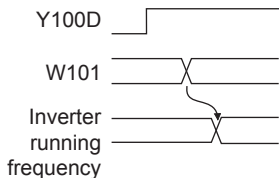

<Timing chart when writing to EEPROM>

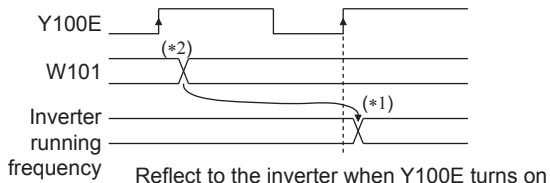

*1 For EEPROM, write is made only once when Y100E is switched on.

*2 If the set data is changed with Y100E on, it is not reflected on the inverter.

8.8 Program example for fault record reading

The following program reads fault records of station 1 inverter to D1.

- Fault record No. 1, No. 2 reading instruction code: H74 (hexadecimal)

For the error codes, refer to the FR-E800 Instruction Manual (Maintenance).

The reply code at the time of instruction code execution is set to D2. (Refer to [page 71](#))

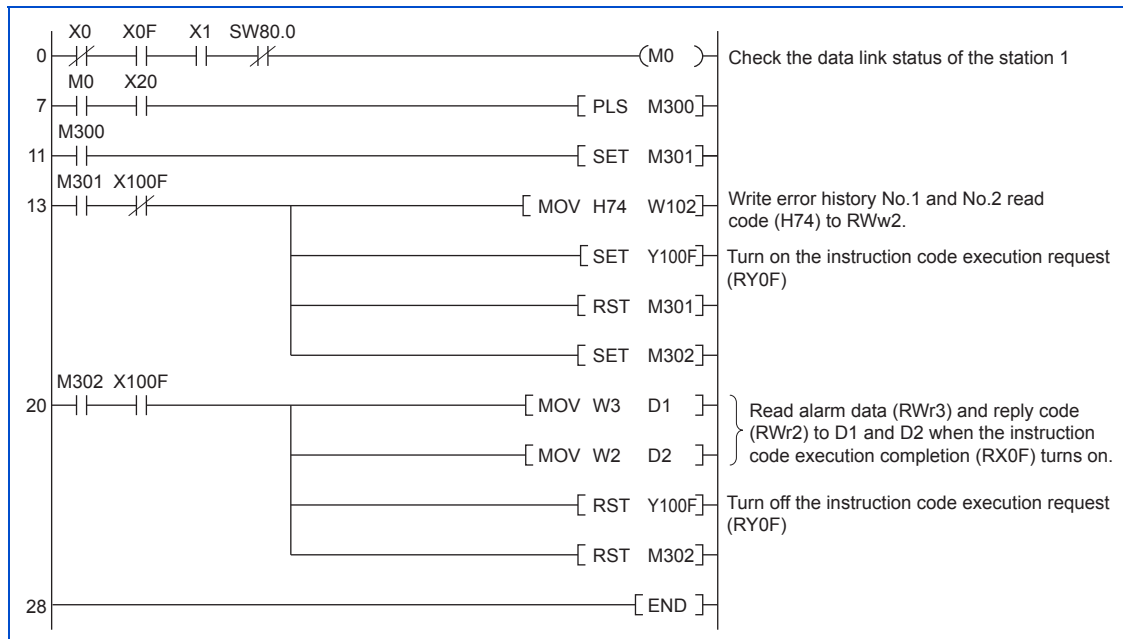

8.9 Program example for resetting the inverter at inverter error

The following is a program example for resetting station 1 inverter.

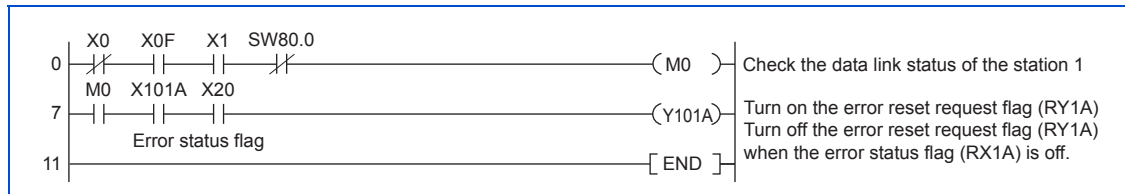

NOTE

- The above inverter reset using RY1A may be made only when an inverter error occurs. When **Pr.349 Communication reset selection** is set to "0", inverter reset is available in any operation mode.
- When using the instruction code execution request (RYF) with the instruction code (HFD) and data (H9696) to reset the inverter, set a value other than "0" in **Pr.340 Communication startup mode selection** (refer to [page 35](#)) or change the operation mode to the network operation mode. (For the program example, refer to [page 86](#))
- Refer to [page 44](#) for operation conditions of inverter reset.

8.10 Instructions

◆ Programming instructions

- Since the buffer memory data of the master station is kept transferred (refreshed) to/from the inverters, the TO instruction need not be executed every scan in response to data write or read requests. The execution of the TO instruction every scan does not pose any problem.
- If the FROM/TO instruction is executed frequently, data may not be written reliably. When transferring data between the inverter and sequence program via the buffer memory, perform the handshake to confirm that data has been written without error.

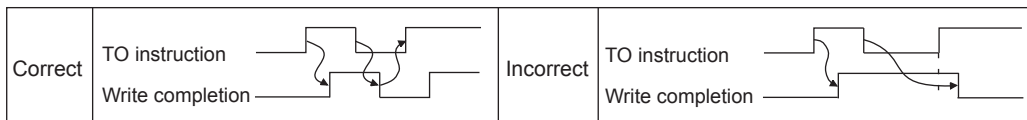

◆ Operating and handling instructions

- Command only from the programmable controller can be accepted during operation from CC-Link communication. Operation commands input from external devices or on the operation panel are ignored.

- If multiple inverters have the same station number, the communication cannot be performed properly.

- The inverter protective function (E.OP1) is activated if data communication stops for more than the time set in **Pr.500 Communication error execution waiting time** due to a programmable controller fault, a CC-Link dedicated cable disconnection etc. during CC-Link operation.

- If the programmable controller (master station) is reset during CC-Link operation or if the programmable controller is powered off, data communication stops and the inverter protective function (E.OP1) is activated.

To reset the programmable controller (master station), switch the operation mode to the external operation once, then reset the programmable controller.

- When **Pr.340** = "0", any inverter whose main power is restored is reset to return to the external operation mode. To resume the network operation, therefore, set the operation mode to the network operation using the programmable controller program.

Set a value other than "0" in **Pr.340** to start in the network operation mode after inverter reset. (Refer to [page 35](#))

◆ Troubleshooting

Description	Check point
Operation mode does not switch to the network operation mode	Check that the option unit (FR-A8NC) and CC-Link dedicated cables are fitted properly. (Check for contact fault, break in the cable, etc.)
	Pr.542 Communication station number (CC-Link) setting switches are set to the correct positions. (Check that the station number matches the program, the station numbers are not repeated, and the station number is not outside the range.)
	Check that the inverter is in the External operation mode.
	Check that the operation mode switching program is running.
Inverter does not start in the Network operation mode	Check that the operation mode switching program has been written correctly.
	Check that the inverter starting program is running.
	Check that the inverter starting program has been written correctly.
	Check that Pr.338 Communication operation command source is not set to external.

9 HOW TO CHECK FOR ERROR USING THE LEDS

9.1 When one inverter is connected

The following diagram shows the system configuration with one inverter. The diagram indicates how the cause of the fault can be checked with the LED status of the inverter communication option (FR-A8NC).

(In this example, assume SW, M/S, and PRM LEDs of the master module are OFF (master module is in normal operation).)

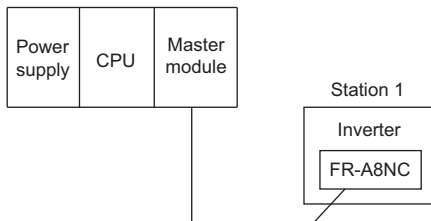

Operation status indication LED

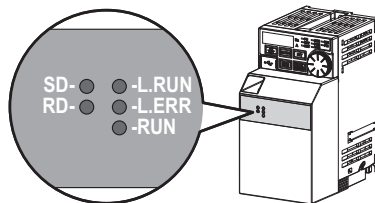

LED status					Cause
RUN	L.RUN	SD	RD	L.ERR	
●	●	◎	◎	◎	Normal communication is made but CRC error has occurred due to noise.
●	●	◎	◎	○	Normal communication
●	●	◎	○	◎	Hardware fault
●	●	◎	○	○	Hardware fault
●	●	○	◎	◎	Cannot answer due to CRC error of receive data.
●	●	○	◎	○	Data sent to the host station does not reach destination.
●	●	○	○	◎	Hardware fault
●	●	○	○	○	Hardware fault
●	○	◎	◎	◎	Polling response is made but refresh receive is in CRC error.
●	○	◎	◎	○	Hardware fault
●	○	◎	○	◎	Hardware fault
●	○	◎	○	○	Hardware fault
●	○	○	◎	◎	Data sent to the host station is in CRC error.
●	○	○	◎	○	There is no data sent to the host station, or data sent to the host station cannot be received due to noise.
●	○	○	○	◎	Hardware fault
●	○	○	○	○	Cannot receive data due to break in the cable, etc.
●	○	○	◎○	●	Invalid baud rate or station number setting
●	●	◎	◎	◎	Baud rate or station number changed during operation.
○	○	○	○	○	Watchdog fault (hardware fault), power disconnection, faulty power supply area
◎	-	-	-	-	Master station is connected to CC-Link ver. 1 and FR-A8NC is connected to CC-Link ver. 2.

●: ON, ○: OFF, ◎: Blinking

9.2 When two or more inverters are connected

The following system configuration shows how the cause of a fault can be checked with the LED status of the inverter communication option (FR-A8NC) and countermeasures for the fault.

(In this example, assume SW, M/S, and PRM LEDs of the master module are OFF (master module is in normal operation).)

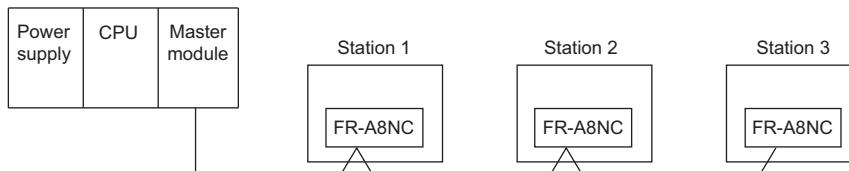

LED status				Cause	Corrective action
Master unit	Inverters (FR-A8NC)				
	Station 1	Station 2	Station 3		
TIME○ LINE○ or TIME● LINE○	RUN● L.RUN● SD● RD● L.ERR○	RUN● L.RUN● SD● RD● L.ERR○	RUN● L.RUN● SD● RD● L.ERR○	Normal	—
	RUN○ L.RUN○ SD○ RD○ L.ERR○	RUN● L.RUN● SD● RD● L.ERR○	RUN● L.RUN● SD● RD● L.ERR○	Contact faults of the FR-A8NC with the station 1 inverter	Plug the FR-A8NC securely. Check the connector.

LED status				Cause	Corrective action
Master unit	Inverters (FR-A8NC)				
	Station 1	Station 2	Station 3		
TIME○ LINE○ or TIME● LINE○	RUN● L.RUN● SD● RD● L.ERR○	RUN● L.RUN○ SD* RD* L.ERR○	RUN● L.RUN○ SD* RD* L.ERR○	Since the L.RUN LEDs of the FR-A8NC on station 2 and later are off, the CC-Link dedicated cable between the remote I/O units A and B is open or disconnected from the CC-Link communication connector.	Referring to the LED "on" condition, search for an open point and repair.
	RUN● L.RUN○ SD* RD* L.ERR○	RUN● L.RUN○ SD* RD* L.ERR○	RUN● L.RUN○ SD* RD* L.ERR○	The CC-Link dedicated cable is shorted.	Identify the shorted wire out of the three wires (blue, white, yellow) of the CC-Link dedicated cable, and repair the wire.
	RUN● L.RUN○ SD* RD* L.ERR*	RUN● L.RUN○ SD* RD* L.ERR*	RUN● L.RUN○ SD* RD* L.ERR*	The CC-Link dedicated cable is wired improperly.	Check if the three wires (blue, white, yellow) of the CC-Link dedicated cable are correctly inserted to the CC-Link communication one-touch connector plug. If any improper connection is found, correct the connection.

●: On, ○: Off, ◎: Blinking, *: Any of on, blinking or off

9.3 Communication stops during operation

- Check that the option unit (FR-A8NC) and CC-Link dedicated cables are fitted properly. (Check for contact fault, break in the cable, etc.)
- Check that the programmable controller program is executed properly.
- Check that data communication has not stopped due to an instantaneous power failure, etc.

LED status				Cause	Corrective action
Master unit	Inverters (FR-A8NC)				
	Station 1	Station 2	Station 3		
TIME○ LINE○ or TIME● LINE○	RUN● L.RUN○ SD* RD● L.ERR○	RUN● L.RUN● SD● RD● L.ERR○	RUN● L.RUN○ SD* RD● L.ERR○	Since the L.RUN LEDs of the FR-A8NC on station 1 and the FR-A8NC on station 3 are off, the station numbers of the inverters set as stations 1 and 3 are the same.	After correcting the repeated station numbers of the inverters using Pr.542 Communication station number (CC-Link) , switch power on again.
	RUN● L.RUN● SD● RD● L.ERR○	RUN● L.RUN○ SD○ RD● L.ERR○	RUN● L.RUN● SD● RD● L.ERR○	Since the L.RUN and SD LEDs of the FR-A8NC on station 2 are off, the transmission speed setting of the FR-A8NC on station 2 is wrong within the setting range (0 to 4).	After correcting the transmission speed setting using Pr.543 Baud rate selection (CC-Link) , switch power on again.
	RUN● L.RUN● SD● RD● L.ERR○	RUN● L.RUN● SD○ RD● L.ERR○	RUN● L.RUN● SD● RD● L.ERR○	Since the L.ERR LED of the FR-A8NC on station 3 blinks, the setting switch of the FR-A8NC on station 3 was moved during normal operation.	After returning the setting switch of the FR-A8NC to the original position using Pr.542 Communication station number (CC-Link) or Pr.543 Baud rate selection (CC-Link) power on the inverter again.

LED status				Cause	Corrective action
Master unit	Inverters (FR-A8NC)				
	Station 1	Station 2	Station 3		
TIME● LINE● or TIME○ LINE●	RUN● L.RUN● SD● RD● L.ERR○	RUN● L.RUN● SD● RD● L.ERR●	RUN● L.RUN● SD● RD● L.ERR○	Since the L.ERR LED of the FR-A8NC on station 2 is on, the FR-A8NC itself on station 1 is affected by noise. (L.RUN may go off.)	Securely earth (ground) each inverter and the master module.
	RUN● L.RUN● SD● RD● L.ERR○	RUN● L.RUN● SD● RD● L.ERR●	RUN● L.RUN● SD● RD● L.ERR●	Since the L.ERR LEDs of the FR-A8NC on station 2 and later are on, the transmission cable between the inverters of stations 2 and 3 is affected by noise. (L.RUN may go off.)	Check if shielding (drain) wires of the CC-Link dedicated cable are properly inserted to the CC-Link communication one-touch connector plug. (Refer to page 22) Also run it as far away as possible from the power lines. (100 mm or more)
	RUN● L.RUN● SD● RD● L.ERR○	RUN● L.RUN● SD● RD● L.ERR○	RUN● L.RUN● SD● RD● L.ERR●	The terminating resistor has been left unfitted, or the one-touch connector plug with terminating resistor has been left unfitted. (L.RUN may go off.)	<ul style="list-style-type: none"> Check that the setting of the terminating resistor selection switch is correct. (Refer to page 31) Use the one-touch connector plug with terminating resistor. (Refer to page 28)

●: On, ○: Off, ◎: Blinking, *: Any of on, blinking or off

APPENDIX

Appendix 1 Instructions for compliance with the EU Directives

The EU Directives are issued to standardize different national regulations of the EU Member States and to facilitate free movement of the equipment, whose safety is ensured, in the EU territory. Since 1996, compliance with the EMC Directive that is one of the EU Directives has been legally required. Since 1997, compliance with the Low Voltage Directive, another EU Directive, has been also legally required. When a manufacturer confirms its equipment to be compliant with the EMC Directive and the Low Voltage Directive, the manufacturer must declare the conformity and affix the CE marking.



- The authorized representative in the EU

The authorized representative in the EU is shown below.

Name: Mitsubishi Electric Europe B.V.

Address: Mitsubishi-Electric-Platz 1, 40882 Ratingen, Germany

◆ EMC Directive

We declare that this product conforms with the EMC Directive when installed in a compatible inverter, and affix the CE marking on the packaging plate.

- EMC Directive: 2014/30/EC
- Standard(s): EN 61800-3:2004+A1:2012 (Second environment / PDS Category "C3")

■ Note

- To install and wire the inverter, refer to the "Instructions for compliance with the EU Directives" in the Instruction Manual enclosed with the inverter.
- Confirm that the final integrated system with the inverter conforms with the EMC Directive.

◆ EU RoHS Directive

We declare that this product conforms with the EU RoHS Directive (2011/65/EU) when installed in a compatible inverter, and affix the CE marking on the packaging plate.

Appendix 2 Instructions for EAC

The product certified in compliance with the Eurasian Conformity has the EAC marking on the packaging plate.

Note: EAC marking

In 2010, three countries (Russia, Belarus, and Kazakhstan) established a Customs Union for the purposes of revitalizing the economy by forming a large economic bloc by abolishing or reducing tariffs and unifying regulatory procedures for the handling of articles.

Products to be distributed over these three countries of the Customs Union must comply with the Customs Union Technical Regulations (CU-TR), and the EAC marking must be affixed to the products.

For information on the country of origin, manufacture year and month, and authorized sales representative (importer) in the CU area of this product, refer to the following:

- Country of origin indication

Check the package of this product.

Example: MADE IN JAPAN

- Manufactured year and month

Check the SERIAL number indicated on this product.

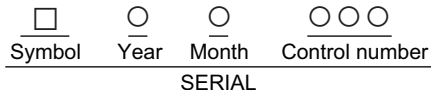

The SERIAL consists of one symbol, two characters indicating the production year and month, and three characters indicating the control number. The last digit of the production year is indicated as the Year, and the Month is indicated by 1 to 9, X (October), Y (November), or Z (December).

- Authorized sales representative (importer) in the CU area

The authorized sales representative (importer) in the CU area is shown below.

Name: Mitsubishi Electric (Russia) LLC

Address: 52, bld 1 Kosmodamianskaya Nab 115054, Moscow, Russia

Phone: +7 (495) 721-2070

Fax: +7 (495) 721-2071

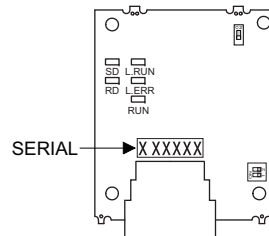

Appendix 3 Restricted Use of Hazardous Substances in Electronic and Electrical Products

The mark of restricted use of hazardous substances in electronic and electrical products is applied to the product as follows based on the "Management Methods for the Restriction of the Use of Hazardous Substances in Electrical and Electronic Products" of the People's Republic of China.

电器电子产品有害物质限制使用标识要求



本产品中所含有的有害物质的名称、含量、含有部件如下表所示。

- 产品中所含有害物质的名称及含量

部件名称 *2	有害物质 *1					
	铅 (Pb)	汞 (Hg)	镉 (Cd)	六价铬 (Cr (VI))	多溴联苯 (PBB)	多溴二苯醚 (PBDE)
电路板组件 (包括印刷电路板及其构成的零部件, 如电阻、电容、集成电路、连接器等)、电子部件	×	○	×	○	○	○
金属壳体、金属部件	×	○	○	○	○	○
树脂壳体、树脂部件	○	○	○	○	○	○
螺丝、电线	○	○	○	○	○	○

上表依据 SJ/T11364 的规定编制。

○：表示该有害物质在该部件所有均质材料中的含量均在 GB/T26572 规定的限量要求以下。

×：表示该有害物质在该部件的至少一种均质材料中的含量超出 GB/T26572 规定的限量要求。

*1 即使表中记载为 ×，根据产品型号，也可能会有有害物质的含量为限制值以下的情况。

*2 根据产品型号，一部分部件可能不包含在产品中。

Appendix 4 Referenced Standard (Requirement of Chinese standardized law)

This Product is designed and manufactured accordance with following Chinese standards.

EMC: GB/T 12668.3

Appendix 5 Compliance with the UK certification scheme

We declare that this product conforms with the related technical requirements under UK legislation when installed in a compatible inverter, and affix the UKCA (UK Conformity Assessed) marking on the packaging plate.

Approval conditions are the same as those for the EU Directives. (Refer to [page 103](#).)



UKCA marking:

The UKCA marking is used for products sold in the markets of Great Britain (England, Wales, and Scotland) from January 1, 2021 after the departure of the UK from the EU on January 31, 2020.

REVISIONS

*The manual number is given on the bottom left of the back cover.

Revision date	*Manual number	Revision
Dec. 2019	IB(NA)-0600886ENG-A	First edition
Dec. 2021	IB(NA)-0600886ENG-B	Added <ul style="list-style-type: none">• Position control• Compliance with the UK certification scheme

INVERTER

mitsubishi **MITSUBISHI ELECTRIC CORPORATION**

HEAD OFFICE: TOKYO BUILDING 2-7-3, MARUNOUCHI, CHIYODA-KU, TOKYO 100-8310, JAPAN