



INVERTER

FR-E800-SCE

Instruction Manual (Functional Safety)

Compact, high functionality inverters

Chapter 1 INTRODUCTION	4
1.1 Compliance with the EU Machinery Directive - Safety sub-functions	5
1.2 Related manuals	10
Chapter 2 Installation and Wiring	11
2.1 Safety communication model	12
2.2 IP67 model	15
Chapter 3 Safety Parameters	16
3.1 Safety parameter setting method	16
3.2 List of safety parameters	18
Chapter 4 I/O Signals for Safety Sub-Functions	20
4.1 I/O signal list	20
4.2 Input terminals (Safety communication model only)	22
4.3 Output terminals (Safety communication model only)	24
Chapter 5 Safety Sub-Functions	25
5.1 STO function	25
5.2 SS1 function	26
5.3 SLS function	27
5.4 SSM function	29
5.5 SBC function (Safety communication model only)	31
Chapter 6 Safety Communication Functions	36
6.1 CC-Link IE TSN safety communication functions	36

6.1.1	Overview	36
6.1.2	Setting procedure for CC-Link IE TSN safety communication functions	37
6.1.3	Safety remote I/O	40
6.2	PROFIsafe	41
<hr/>		
6.2.1	Overview	41
6.2.2	Setting procedure for PROFIsafe	42
6.2.3	Data Exchange	43
6.3	CIP Safety	46
<hr/>		
6.3.1	Overview	46
6.3.2	Setting procedure of CIP Safety	48
6.3.3	Object map	50
6.3.4	Restrictions and precautions	54
Chapter 7 Protective Functions		55
<hr/>		
Chapter 8 Safety Specifications		58
<hr/>		
Warranty		62
Revisions		63

1 INTRODUCTION

The contents described in this chapter must be read before using this product.
Always read the instructions before use.

◆ Abbreviations

Item	Description
PU	Operation panel, parameter unit (FR-PU07), LCD operation panel (FR-LU08), and enclosure surface operation panel (FR-PA07)
Parameter unit	Parameter unit (FR-PU07), LCD operation panel (FR-LU08) and enclosure surface operation panel (FR-PA07)
Inverter	Mitsubishi Electric inverter FR-E800 series
E800	Standard model (RS-485 + SIL2/PLd functional safety)
E800-E	Ethernet model (Ethernet + SIL2/PLd functional safety)
E800-SCE	Safety communication model (Ethernet + SIL3/PLe functional safety)
E806	IP67 model (Ethernet + SIL3/PLe functional safety + IP67)
Pr.	Parameter number (Number assigned to function)

◆ Digital characters and their corresponding printed equivalents

0	1	2	3	4	5	6	7	8	9	A	B	C
0	1	2	3	4	5	6	7	8	9	A	b	C
D	E	F	G	H	I	J	K	L	M	N	O	P
d	E	F	G	H	I	J	K	L	N	n	O	P
Q	R	S	T	U	V	W	X	Y	Z	-	-	
q	r	s	t	u	v	w	x	y	z	-	-	

◆ Trademarks

- MODBUS is a registered trademark of SCHNEIDER ELECTRIC USA, INC.
- BACnet is a registered trademark of the American Society of Heating, Refrigerating and Air-Conditioning Engineers (ASHRAE).
- DeviceNet, EtherNet/IP, and CIP Safety are registered trademarks of ODVA (Open DeviceNet Vendor Association, INC).
- PROFIBUS, PROFINET, and PROFIsafe are either trademarks or registered trademarks of PROFIBUS & PROFINET International.
- CC-Link IE TSN and CC-Link IE Field Network Basic are registered trademarks of CC-Link Partner Association.
- Other company and product names herein are either trademarks or registered trademarks of their respective owners.

1.1 Compliance with the EU Machinery Directive - Safety sub-functions

◆ Safety communication model

Mitsubishi Electric FR-E800-SCE series general-purpose inverters have met the SIL 3 requirements of the international standard IEC 61508:2010 for functional safety.

	FR-E800-SCE
Safety performance (Standards)	ISO 13849-1:2015 Category 3/PLe IEC 62061:2021 / IEC 61800-5-2:2016 / IEC 61508:2010 SIL3 IEC 61800-5-2:2016 Stop category 0, 1

This product supports safety sub-functions (STO, SS1, SLS, SSM, and SBC) specified in IEC 61800-5-2.

By connecting the inverter with a safety programmable controller with an Ethernet cable, signal input via safety communication is enabled.

To use safety sub-functions, any work on the product such as wiring and inspections must be performed according to the Instruction Manual by technicians who took a safety standard training.

WARNING

- Any misuse of safety sub-functions may cause physical injury, damage to property, or economic loss. To confirm that the system is compliant with safety standards, a risk assessment must be conducted for the entire system. We shall not be liable for the compliance of the system with safety standards.
- To avoid an electric shock hazard, verify that the voltage on the bus capacitors has discharged before working on the inverter. Measure the DC bus voltage between terminals P/+ and N/- or other measurement points to verify zero voltage. (For the measurement points and the capacitor discharge time, refer to the Instruction Manual of the inverter.)
- When the power supply to the gate drive circuit is shut off by a safety sub-function, the inverter and the motor are not insulated each other. To avoid an electric shock hazard, verify that the voltage on the bus capacitors has discharged before wiring or inspection of the motor. Measure the DC bus voltage between terminals P/+ and N/- or other measurement points to verify zero voltage. (For the measurement points and the capacitor discharge time, refer to the Instruction Manual of the inverter.)

CAUTION

- Check safety sub-functions at least once per three months. Also, check the functions at system installation, any software changes, and parameter setting changes.
- The following information is merely a guide for proper installation.

We shall not be liable for the compliance or non-compliance with any local, national, or international codes or regulations for the installation of this product.

Installation not compliant with applicable codes or directives may cause physical injury or damage to property.

◆ IP67 model

Mitsubishi Electric FR-E806 series general-purpose inverters have met the SIL 3 requirements of the international standard IEC 61508:2010 for functional safety.

	FR-E806
Safety performance (Standards)	ISO 13849-1:2015 Category 3/PLe IEC 62061:2021 / IEC 61800-5-2:2016 / IEC 61508:2010 SIL3 IEC 61800-5-2:2016 Stop category 0, 1

This product supports safety sub-functions (STO, SS1, SLS, and SSM) specified in IEC 61800-5-2.

By connecting the inverter with a safety programmable controller with an Ethernet cable, signal input via safety communication is enabled.

To use safety sub-functions, any work on the product such as wiring and inspections must be performed according to the Instruction Manual by technicians who took a safety standard training.

WARNING

- Any misuse of safety sub-functions may cause physical injury, damage to property, or economic loss. To confirm that the system is compliant with safety standards, a risk assessment must be conducted for the entire system. We shall not be liable for the compliance of the system with safety standards.
- To avoid an electric shock hazard, verify that the voltage on the bus capacitors has discharged before working on the inverter. Measure the DC bus voltage between terminals P/+ and N/- or other measurement points to verify zero voltage. (For the measurement points and the capacitor discharge time, refer to the Instruction Manual of the inverter.)
- When the power supply to the gate drive circuit is shut off by a safety sub-function, the inverter and the motor are not insulated each other. To avoid an electric shock hazard, verify that the voltage on the bus capacitors has discharged before wiring or inspection of the motor. Measure the DC bus voltage between terminals P/+ and N/- or other measurement points to verify zero voltage. (For the measurement points and the capacitor discharge time, refer to the Instruction Manual of the inverter.)

CAUTION

- Check safety sub-functions at least once per three months. Also, check the functions at system installation, any software changes, and parameter setting changes.
- The following information is merely a guide for proper installation.

We shall not be liable for the compliance or non-compliance with any local, national, or international codes or regulations for the installation of this product.

Installation not compliant with applicable codes or directives may cause physical injury or damage to property.

◆ Specifications

Function		Description	
Safety sub-function (IEC/EN 61800-5-2)	STO (Safe torque off)	Shut-off response time	140 ms or less
	SS1 (Safe stop 1)	Deceleration delay time	0 to 3600 s (parameter setting)
	SLS (Safely-limited speed)	Monitoring speed	0 to 60 Hz (parameter setting)
	SSM (Safe speed monitor)	Monitoring speed	0 to 60 Hz (parameter setting)
	SBC (Safe brake control)	Shut-off response time	140 ms or less
Input/output function	Input terminal	Number of input terminals	FR-E800-SCE: 1 terminal × 2 channels FR-E806: 0
		Redundant input mismatch detection mismatch permissible time	0.1 to 2 s (parameter setting)
		Filtering time	0.01 to 0.10 s (parameter setting)
	Output terminal	Number of output terminals	FR-E800-SCE: 1 terminal × 2 channels FR-E806: 0
		Test pulse off time	2 ms or 4 ms (parameter setting)
		Test pulse interval	1.5 s or less
Safety parameter setting		Password protection for writing	
Response time ^{*1}		140 ms or less The response time is the time from when the operation command is given for a safety sub-function until the function is activated.	
Safety function response time (IEC 61784-3)		The safety function response time (SFRT) is defined in IEC 61784-3. When a fault occurs, the response time is calculated as follows. SFRT = specified response time + maximum permissible time for delay in safety communication ^{*2} + 60 ms	

*1 Retain the command input for a safety sub-function for a time period equal to or longer than the response time. Otherwise, the intended function may not be activated.

*2 Refer to details of safety communication functions to set an appropriate timeout time.

◆ Motor speed estimation

Motor speed estimation is performed during operation of the SLS, SSM, and SBC functions (when **Pr.S023 SBC brake operation frequency** ≠ "0").

■ Specifications

Item	Description
Applicable control method	V/F control Advanced magnetic flux vector control Real sensorless vector control Vector control
Applicable motor	Induction motor
Speed estimation deviation	Motor slip amount
Operating speed range	2 to 60Hz

■ Operating conditions

- Select a motor with the rated current equal to or less than the inverter rated current. As a reference, select the motor with the rated motor current that is 40% or higher of the inverter rated current.
- Perform single-motor operation (one motor to one inverter).
- Set "2" or larger value in **Pr.72 PWM frequency selection**.
- The wiring length from inverter to motor is 100 m or less.
- The function is not available in the following conditions.
 - Energy saving operation mode, Optimum excitation control mode.
 - Variable torque pattern.
 - During offline auto tuning.
 - While online auto tuning is performed at startup.
 - When starting and stopping or acceleration and deceleration are repeated in a short time (approx. within 2 seconds).
 - During DC injection braking, zero speed control, servo lock operation, or magnetic flux decay output shutoff.
 - During restart coasting time.
 - During test operation.
 - When the motor is rotated by external force.

◆ Risk assessments

To ensure safety, users should conduct all risk assessments and determine residual risks for the entire machine equipment. The company or individual who constructed the safety system must take full responsibility for installation and commissioning of the system. To comply with the EU Machinery Directive, the system as a whole must be certified as compliant with applicable safety standards.

Conduct all risk assessments and obtain the safety level certification for the machine or the system as a whole. It is recommended to obtain the final safety certification by a third-party certification body.

The following shows residual risks concerning safety sub-functions of this product.

- Before shipment, check the settings of safety related parts with programming tools and on the display, and keep a record of the setting data concerning safety related parts and the programming tools used for checking using a check sheet or other form.
- Safety is not assured during the machine assembly or other process before completion of the installation, wiring, and adjustment. Install, wire, and adjust the system referring to the installation guide of each unit.
- Only qualified personnel are authorized to install, start-up, repair, or adjust the system in which devices are installed. Only properly trained engineers should install and operate the equipment.
- Separate the wiring for safety sub-functions from other signal wiring.
- Provide appropriate protections for cables (routing them in an enclosure, using a cable guard, or in other ways).
- It is recommended to use switches, relays, sensors, and other devices that comply with safety standards. When switches, relays, sensors, and other devices are not compliant with safety standards, users must prove the safety of the devices.
- Keep the required clearance/creepage distance depending on the voltage used.
- The time before the protective function (E.SAF) is activated may differ depending on parameter settings.
- Speed monitoring functions (SLS, SSM, and SBC) are used to monitor the output frequency. These functions are not used to monitor or guarantee the rotor speed of the motor. Set parameters so that the safe speed of the machine corresponds to the safe speed of the motor.
- When a speed monitoring function (SLS, SSM, or SBC) is used, check that the monitored speed of the motor axis is the same as the actual speed using a rotation speed meter or other meter, with the errors due to motor slippage taken into account.
- For the operation using speed monitoring functions (SLS, SSM, and SBC), defects of mechanical parts such as slippage of the shaft and coming off of the timing belt are out of the scope of guarantee. Be sure to eliminate risks of mechanical parts in advance.
- When the speed is monitored while the SLS function is enabled, the protective function (E.SAF) is not activated for the time period set by the parameter for the SLS speed detection delay time after a speed fault is detected. Make sure that safety can be guaranteed during this period.
- When the safe speed monitor (SSM) function is used as a restart trigger, perform it according to IEC/EN 60204-1.
- The safe brake control (SBC) function only guarantees that power is properly supplied to the mechanical brake, and it does not detect abrasion of the brake. The mechanic brake operation must be checked periodically.

1.2 Related manuals

When using this inverter for the first time, prepare the following manuals as required and use the inverter safely. The latest version of e-Manual Viewer and the latest PDF manuals can be downloaded from the Mitsubishi Electric FA Global Website. <https://www.mitsubishielectric.com/app/fa/download/search.do?kisyu=/inv&mode=manual>

Point 

- e-Manual refers to the Mitsubishi FA electronic book manuals that can be browsed using a dedicated tool.
- e-Manual has the following features:
 - Required information can be cross-searched in multiple manuals.
 - Pages that users often browse can be bookmarked.

Manuals related to the FR-E800 inverter are shown in the following table.

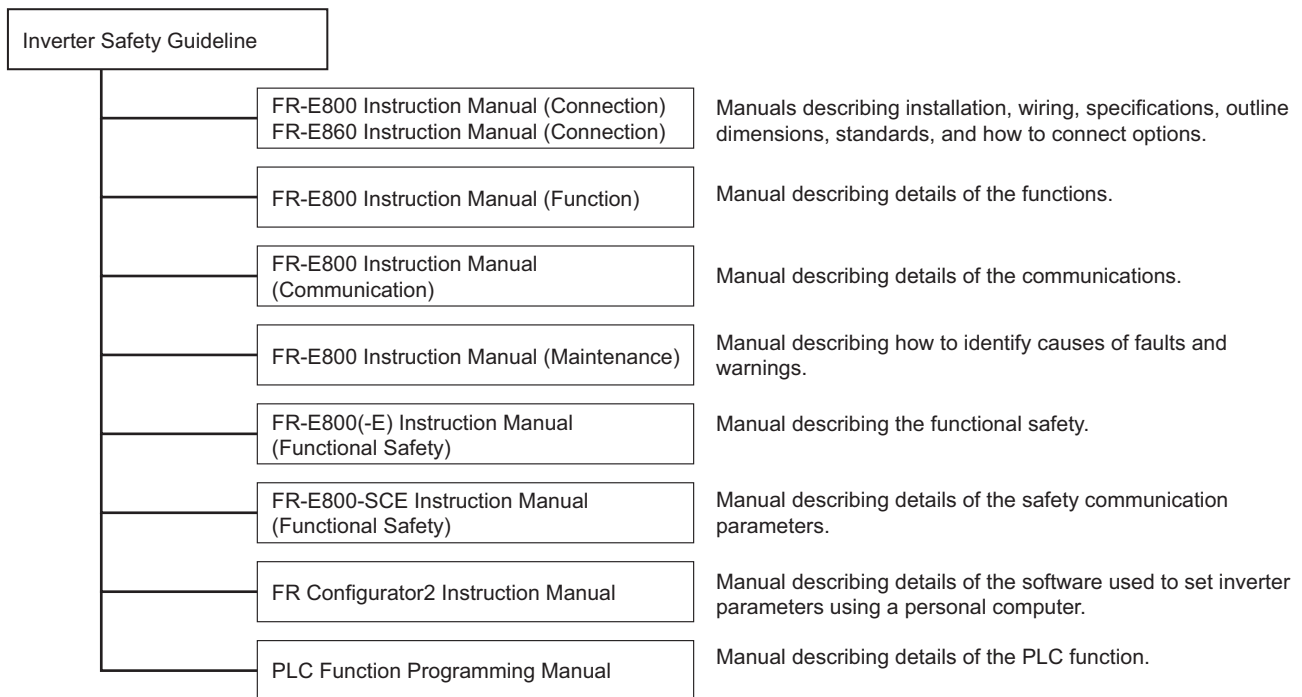

Name	Manual number
FR-E800 Inverter Safety Guideline	IB-0600857ENG
FR-E860 Inverter Safety Guideline	IB-0600862ENG
FR-E800-E Inverter Safety Guideline	IB-0600860ENG
FR-E860-E Inverter Safety Guideline	IB-0600863ENG
FR-E800-SCE Inverter Safety Guideline	IB-0600921ENG
FR-E860-SCE Inverter Safety Guideline	IB-0600924ENG
FR-E806-SCE Inverter Safety Guideline	IB-0600984ENG
FR-E800 Instruction Manual (Connection)	IB-0600865ENG
FR-E860 Instruction Manual (Connection)	IB-0600906ENG
FR-E800 Instruction Manual (Function)	IB-0600868ENG
FR-E800 Instruction Manual (Communication)	IB-0600871ENG
FR-E800 Instruction Manual (Maintenance)	IB-0600874ENG
FR Configurator2 Instruction Manual	IB-0600516ENG
PLC Function Programming Manual	IB-0600492ENG

2 Installation and Wiring

⚠ CAUTION

- Ensure the safety programmable controller and the inverter are mounted closely in an enclosure meeting IP54 and all interconnection wiring is short and protected against open and short circuit faults. For details, refer to ISO/IEC 13849-2.

◆ Installation

Safety sub-functions of the Mitsubishi Electric FR-E800-SCE and FR-E806 inverters should be used under the following conditions and environment.

Item	Condition
Surrounding air temperature	FR-E800-SCE: -20°C to +60°C (non-freezing) ^{*1} FR-E806: -20°C to +50°C (non-freezing) ^{*2}
Ambient humidity	With circuit board coating (conforming to IEC 60721-3-3:1994 3C2): 95% RH or less (non-condensing), without circuit board coating: 90% RH or less (non-condensing)
Storage temperature	-40°C to +70°C ^{*3}
Vibration	5.9 m/s ² or less at 10 to 55 Hz (in either X, Y, or Z direction)
Altitude	200/400 V class: Maximum 3000 m. 575 V class: Maximum 2000 m. ^{*4}
Atmosphere	Indoors (free from corrosive gas, flammable gas, oil mist, dust and dirt)
Overvoltage category	III or lower
Pollution degree	II or lower
Installation	Vertical installation in the enclosure

*1 Derate the rated current when using the inverter in a temperature of 50°C or higher.

*2 Derate the rated current when using the inverter in a temperature of 40°C or higher.

*3 Temperature applicable for a short time, for example, in transit.

*4 For installation at an altitude above 1000 m, consider a 3% reduction in the rated current per 500 m increase in altitude.

⚠ WARNING

- To avoid an electric shock hazard, install a magnetic contactor (MC) at the input side of the inverter.
- Before wiring or inspection of the inverter, open the contact of MC to switch OFF the power and check that the display of the operation panel is OFF. Any person who is involved in wiring or inspection shall wait for 10 minutes or longer after power OFF and check the voltage on the bus capacitors (between terminals P/+ and N/-) using a digital multimeter or other tester. The capacitor is charged with high voltage for some time after power OFF, and it is dangerous.

2.1 Safety communication model

◆ Wiring

The following describes terminals related to safety sub-functions.

Terminal symbol	Terminal name	Terminal function description	Rated specification
SX1	Safety input (channel 1)	Terminal functions can be selected using Pr.S051 SX1/SX2 terminal function selection . (Refer to page 22 .)	Input resistance: 4.7 kΩ, voltage when contacts are open: 21 to 26 VDC, current when contacts are short-circuited: 4 to 6 mADC
SX2	Safety input (channel 2)		
SY1	Safety output (channel 1)	The terminal function can be selected using Pr.S055 SY1/SY2 terminal function selection . (Refer to page 24 .)	Permissible load: 24 VDC (27 VDC at maximum), 0.1 A (The voltage drop is 3.4 V at maximum while the signal is ON.)
SY2	Safety output (channel 2)		
SD	External transistor common (source (positive common))	Connect this terminal to the power supply common terminal of a transistor output (open collector output) device, such as a programmable controller, in the source logic to avoid malfunction by undesirable current.	-
	24 VDC power supply common	Common terminal for the 24 VDC power supply (terminal PC). Isolated from terminal 5.	-
PC	Safety input terminal common	Common terminal for SX1 and SX2.	Power supply voltage range: 22 to 26.5 VDC, permissible load current: 100 mA
	24 VDC power supply	Can be used as a 24 VDC 0.1 A power supply.	
SC1/SC2	Safety output terminal common	Common terminal for SY1 and SY2.	-

◆ Terminal layout

FR-E800-SCE

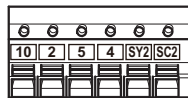
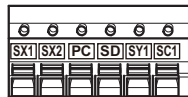

◆ Crimp terminal specifications

Wire size (mm ²)	Ferrule part No. ^{*1}	Crimping tool model No. ^{*1}
0.3	AI 0,34-10TQ	CRIMPFOX 6
0.5	AI 0,5-10WH	
0.75	AI 0,75-10GY	
1	AI 1-10RD	
1.25/1.5	AI 1,5-10BK	
0.75 (for 2 wires)	AI TWIN 2 X 0,75-10GY	

*1 Ferrules and the tool are distributed by Phoenix Contact Co., Ltd.

NOTE

- For Ethernet communication wiring, refer to the FR-E800 Instruction Manual (Communication).
- Use PORT1 for connection with the master for PROFI-safe or CIP Safety communication.

◆ Configuration example

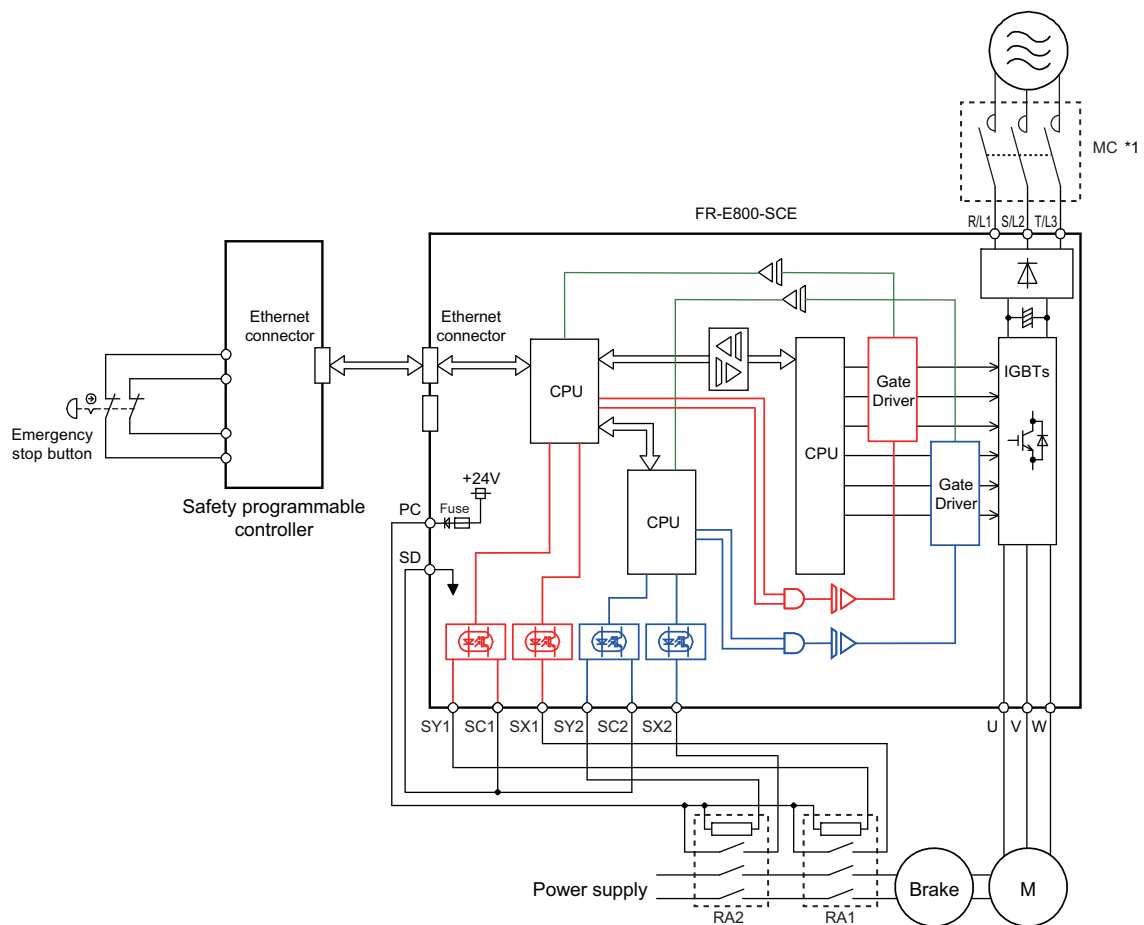

*1 To avoid an electric shock hazard during wiring or inspection, install a magnetic contactor (MC) at the input side of the inverter.

◆ Multiple inverter configuration example

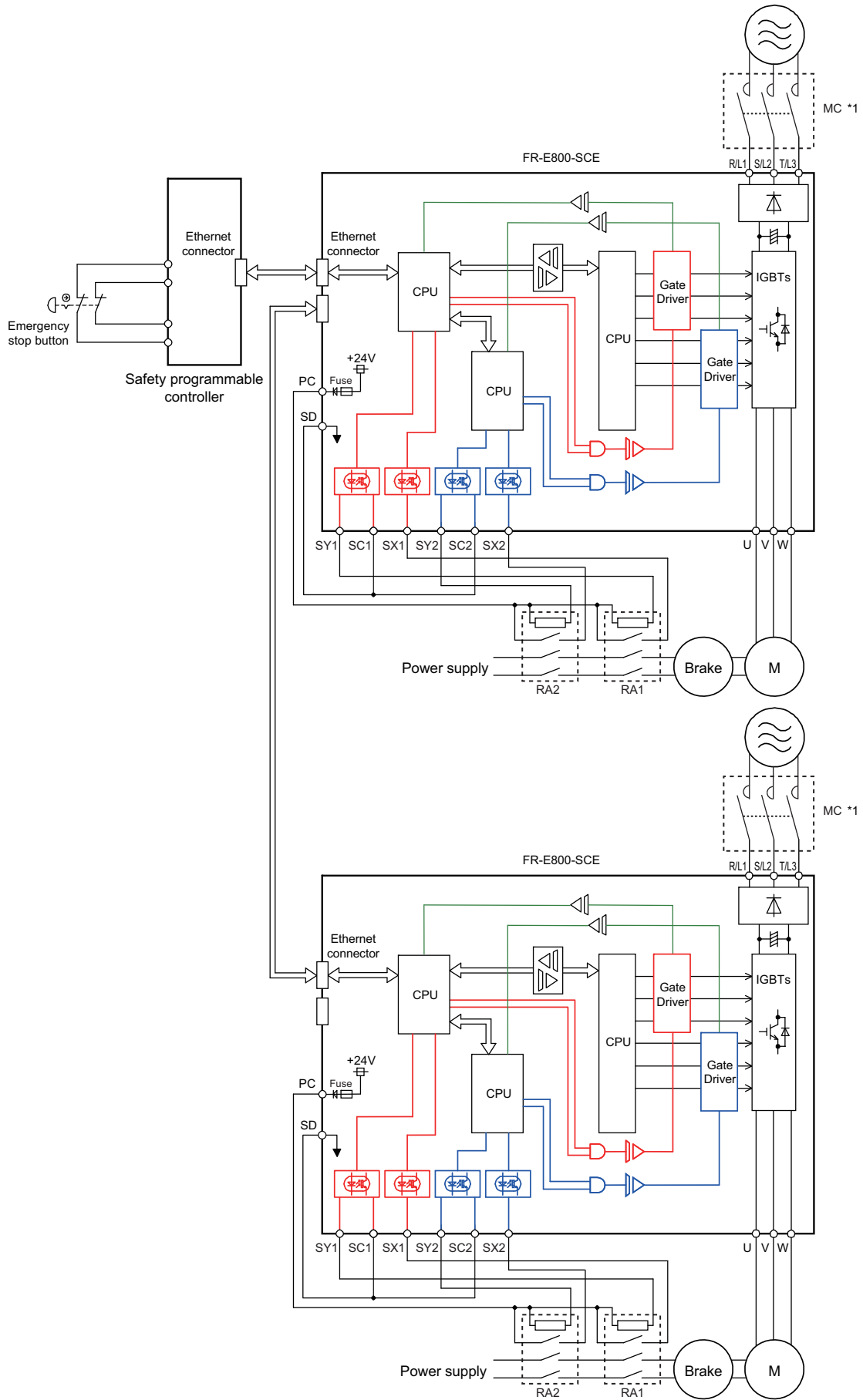

*1 To avoid an electric shock hazard during wiring or inspection, install a magnetic contactor (MC) at the input side of the inverter.

2.2 IP67 model

◆ Wiring

Terminals (physical terminals) related to safety sub-functions are not provided.

NOTE

- For Ethernet communication wiring, refer to the FR-E800 Instruction Manual (Communication).
- Use PORT1 for connection with the master for PROFI-safe or CIP Safety communication.

◆ Configuration example

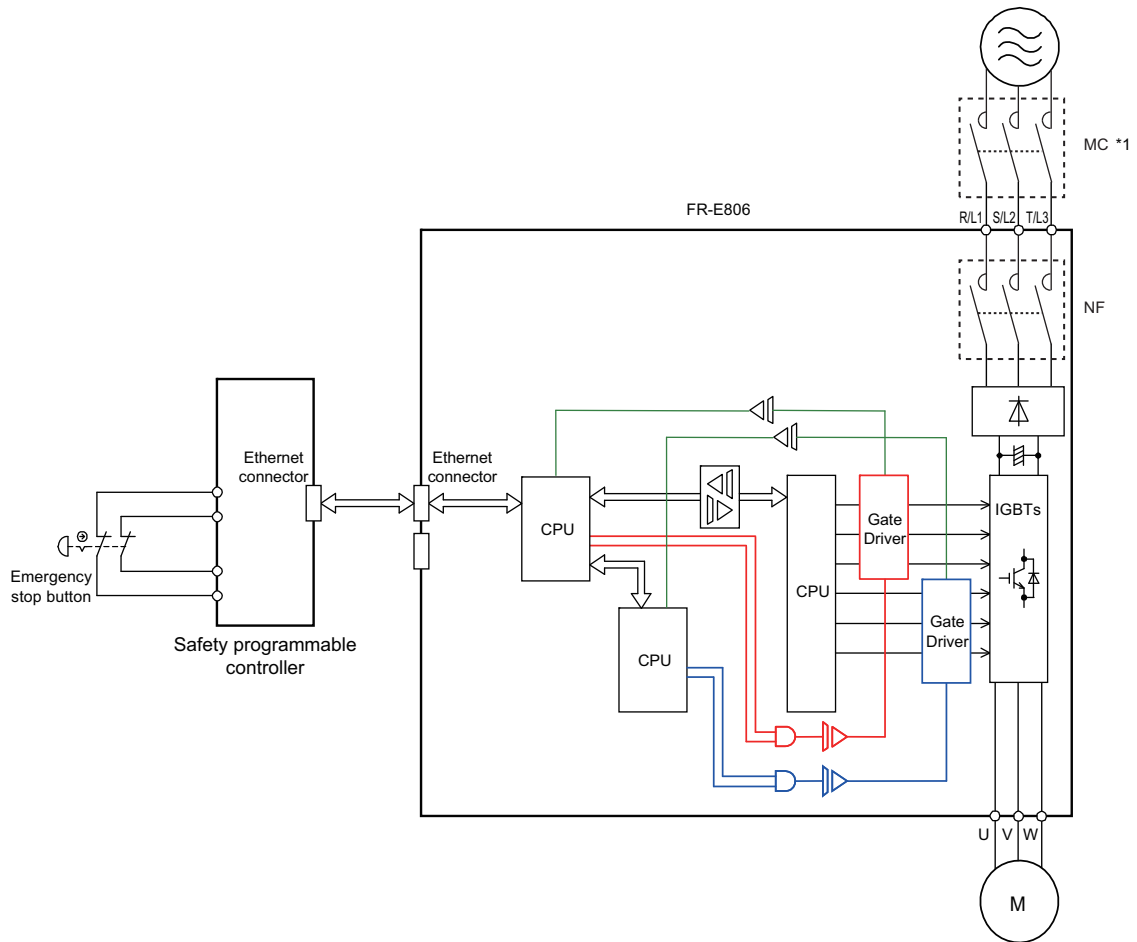

*1 To avoid an electric shock hazard during wiring or inspection, install a magnetic contactor (MC) at the input side of the inverter.

3 Safety Parameters

3.1 Safety parameter setting method

Use FR Configurator2 to set safety parameters. For details, refer to the FR Configurator2 Instruction Manual. The operation panel and the parameter unit are not available for reading or writing safety parameters.

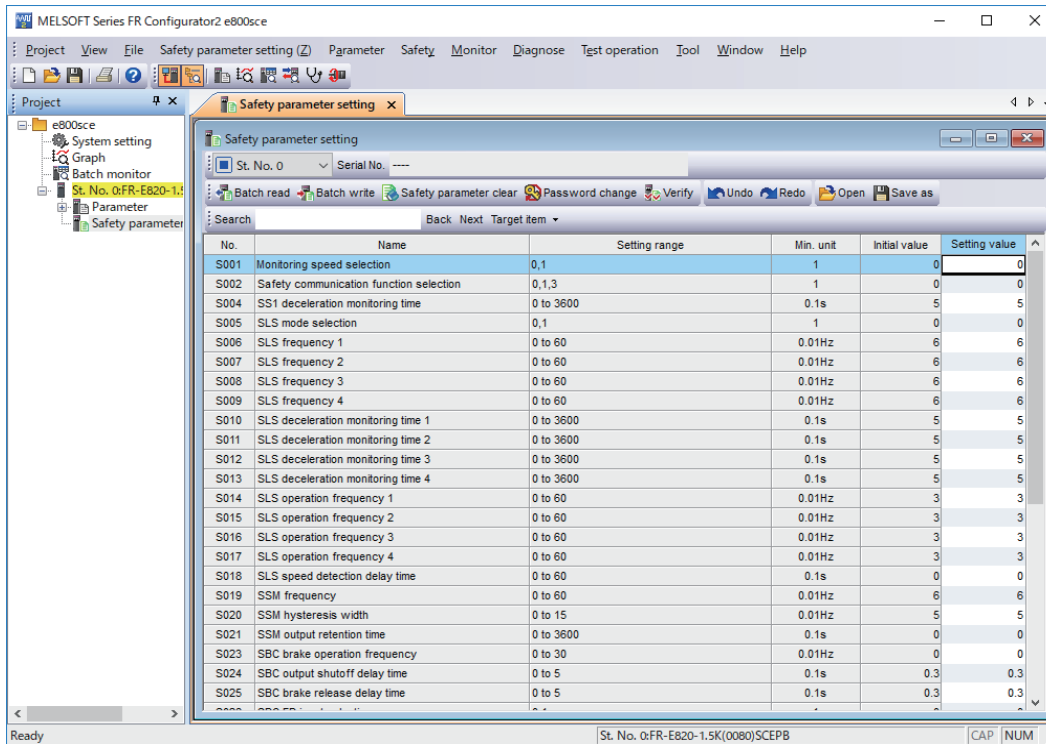

◆ Inverter setup software

Use FR Configurator2 to set safety parameters. Operation must be performed by qualified personnel.

Name	Compatible version
FR Configurator2	1.22Y or later

◆ Setting procedure

1. Safety parameter setting

Refer to the setting method of each parameter and set safety parameters. If a value outside the range is set, the message "The input data is incorrect." appears on FR Configurator2.

Keep the record of the setting values in the customer setting column of the safety parameter list ([page 18](#)) and check them before writing safety parameters.

2. Password setting

Provide password protection for safety parameters to avoid accidental changes.

Passwords must contain one to six alphanumeric characters. Passwords are case-sensitive. (Initial value "000000".)

3. Safety parameter verification

Read safety parameters and compare the settings with those recorded in the customer setting column of the safety parameter list ([page 18](#)) to check that they are correctly set.

4. Power reset or inverter reset

Safety parameter settings and the password become effective after the next power-ON or inverter reset.

5. Operation check of safety sub-functions

Check that safety sub-functions work properly by actually operating the system.

3.2 List of safety parameters

The following parameters are parameters used for safety sub-functions. Set the parameters according to the application.

Notation

Mark	Description	Safety communication function
[E800-SCEPA] [E806-SCEPA]	Available for the Protocol group A.	CC-Link IE TSN safety communication function, CIP Safety
[E800-SCEPB] [E806-SCEPB]	Available for the Protocol group B.	CC-Link IE TSN safety communication function, PROFIsafe

Pr.	Name	Setting range	Minimum setting increments	Initial value	Refer to page	Customer setting
S001	Monitoring speed selection	0, 1	1	0	27, 29, 31	
S002	Safety communication function selection	[E800-SCEPA] [E806-SCEPA] 0, 1, 2 [E800-SCEPB] [E806-SCEPB] 0, 1, 3	1	0	36, 41, 46	
S004	SS1 deceleration monitoring time	0 to 3600s	0.1 s	5 s	26	
S005	SLS mode selection	0, 1	1	0	27	
S006	SLS frequency 1	0 to 60 Hz	0.01 Hz	6 Hz	27	
S007	SLS frequency 2	0 to 60 Hz	0.01 Hz	6 Hz	27	
S008	SLS frequency 3	0 to 60 Hz	0.01 Hz	6 Hz	27	
S009	SLS frequency 4	0 to 60 Hz	0.01 Hz	6 Hz	27	
S010	SLS deceleration monitoring time 1	0 to 3600 s	0.1 s	5 s	27	
S011	SLS deceleration monitoring time 2	0 to 3600 s	0.1 s	5 s	27	
S012	SLS deceleration monitoring time 3	0 to 3600 s	0.1 s	5 s	27	
S013	SLS deceleration monitoring time 4	0 to 3600 s	0.1 s	5 s	27	
S014	SLS operation frequency 1	0 to 60 Hz	0.01 Hz	3 Hz	27	
S015	SLS operation frequency 2	0 to 60 Hz	0.01 Hz	3 Hz	27	
S016	SLS operation frequency 3	0 to 60 Hz	0.01 Hz	3 Hz	27	
S017	SLS operation frequency 4	0 to 60 Hz	0.01 Hz	3 Hz	27	
S018	SLS speed detection delay time	0 to 60 s	0.1 s	0 s	27	
S019	SSM frequency	0 to 60 Hz	0.01 Hz	6 Hz	29	
S020	SSM hysteresis width	0 to 15 Hz	0.01 Hz	5 Hz	29	
S021	SSM output retention time	0 to 3600 s	0.1 s	0 s	29	
S023 ^{*1}	SBC brake operation frequency	0 to 30 Hz	0.01 Hz	0 Hz	31	
S024 ^{*1}	SBC output shutoff delay time	0 to 5 s	0.1 s	0.3 s	31	
S025 ^{*1}	SBC brake release delay time	0 to 5 s	0.1 s	0.3 s	31	
S026 ^{*1}	SBC FB input selection	0, 1	1	0	31	
S027 ^{*1}	SBC mismatch detection time	0 to 5 s	0.1 s	2 s	31	
S051 ^{*1}	SX1/SX2 terminal function selection	0, 6	1	0	22, 31	
S055 ^{*1}	SY1/SY2 terminal function selection	0, 1	1	0	24, 31	
S061 ^{*1}	SX1/SX2 terminal filtering time	0.01 to 0.1 s	0.01 s	0.01 s	22	
S066 ^{*1}	SX1/SX2 terminal mismatch permissible time	0 to 2 s	0.1 s	0.2 s	22	
S070 ^{*1}	SY1/SY2 terminal test pulse diagnosis execution selection	0, 1	1	0	24	
S071 ^{*1}	SY1/SY2 terminal test pulse off time	0, 1	1	0	24	

*1 Available for the safety communication model only.

◆ Parameters for CC-Link IE TSN safety communication functions

Pr.	Name	Setting range	Minimum setting increments	Initial value	Refer to page	Customer setting
S030	CC-Link IE TSN safety communication function - Transmission interval monitoring time	128 to 1000 ms	1 ms	128 ms	36	
S031	CC-Link IE TSN safety communication function - Safety certification code (upper)	0 to 65535	1	65535	36	
S032	CC-Link IE TSN safety communication function - Safety certification code (lower)	0 to 65535	1	65535	36	

◆ Parameter for PROFI-safe

The parameter is available for the FR-E800-SCEPB and FR-E806-SCEPB only.

Pr.	Name	Setting range	Minimum setting increments	Initial value	Refer to page	Customer setting
S089	PROFI-safe address	0 to 65534	1	0	41	

◆ Parameters for CIP Safety

These parameters are available for the FR-E800-SCEPA and FR-E806-SCEPA only.

Pr.	Name	Setting range	Minimum setting increments	Initial value	Refer to page	Customer setting
S135	CIP Safety TUNID 1 (SNN1)	0 to 65535	1	65535	46	
S136	CIP Safety TUNID 2 (SNN2)	0 to 65535	1	65535	46	
S137	CIP Safety TUNID 3 (SNN3)	0 to 65535	1	65535	46	
S138	CIP Safety TUNID 4 (IP address 1, 2)	0 to 65535	1	65535	46	
S139	CIP Safety TUNID 5 (IP address 3, 4)	0 to 65535	1	65535	46	
S140	CIP Safety OCPUNID 1 (SNN1)	0 to 65535	1	0	46	
S141	CIP Safety OCPUNID 2 (SNN2)	0 to 65535	1	0	46	
S142	CIP Safety OCPUNID 3 (SNN3)	0 to 65535	1	0	46	
S143	CIP Safety OCPUNID 4 (IP address 1, 2)	0 to 65535	1	0	46	
S144	CIP Safety OCPUNID 5 (IP address 3, 4)	0 to 65535	1	0	46	
S145	CIP Safety SCID 1 (SCTS1)	0 to 65535	1	0	46	
S146	CIP Safety SCID 2 (SCTS2)	0 to 65535	1	0	46	
S147	CIP Safety SCID 3 (SCTS3)	0 to 65535	1	0	46	
S148	CIP Safety SCID 4 (SCCRC1)	0 to 65535	1	0	46	
S149	CIP Safety SCID 5 (SCCRC2)	0 to 65535	1	0	46	

4 I/O Signals for Safety Sub-Functions

4.1 I/O signal list

Signals are input or output by using physical terminals (for the SBC function only) or via safety communication.

◆ Input/output by using physical terminals (Safety communication model only)

- Input signal

Signal name	Function	Description ^{*1}	Refer to page
SBCFB	Brake feedback	Used to check the brake status. The logic (ON/OFF) of the signal for normal brake operation is selected by setting Pr.S026 SBC FB input selection .	31

*1 The terminal ON state shows that the terminal is conducted (the line is closed), and the OFF state shows that the terminal is not conducted (the line is open).

- Output signal

Signal name	Function	Description ^{*1}	Refer to page
SBC	SBC output	Used to control the application or release of the brake. ON: Release the brake. OFF: Apply the brake.	31

*1 The terminal ON state shows that the terminal is conducted (the line is closed), and the OFF state shows that the terminal is not conducted (the line is open).

◆ Input/output by using safety communication

- Input signal

Signal name	Function	Description ^{*1}	Refer to page
STOC	STO command	OFF (0): STO function enabled. ON (1): STO function disabled.	25
SS1C	SS1 command	OFF (0): SS1 function enabled. ON (1): SS1 function disabled.	26
SLS1C	SLS1 command	OFF (0): SLS1 function enabled. ON (1): SLS1 function disabled.	27
SLS2C	SLS2 command	OFF (0): SLS2 function enabled. ON (1): SLS2 function disabled.	27
SLS3C	SLS3 command	OFF (0): SLS3 function enabled. ON (1): SLS3 function disabled.	27
SLS4C	SLS4 command	OFF (0): SLS4 function enabled. ON (1): SLS4 function disabled.	27
SSMC	SSM command	OFF (0): SSM function enabled. ON (1): SSM function disabled.	29

*1 The value "0" or "1" in the parentheses is the bit value.

- Output signal

Signal name	Function	Description ^{*1}	Refer to page
STOS	STO output	OFF (1): STO function enabled. ON (0): STO function disabled.	25
SS1S	SS1 output	OFF (1): SS1 function enabled. ON (0): SS1 function disabled.	26
SLS1S	SLS1 output	OFF (1): SLS1 function enabled. ON (0): SLS1 function disabled.	27
SLS2S	SLS2 output	OFF (1): SLS2 function enabled. ON (0): SLS2 function disabled.	27
SLS3S	SLS3 output	OFF (1): SLS3 function enabled. ON (0): SLS3 function disabled.	27
SLS4S	SLS4 output	OFF (1): SLS4 function enabled. ON (0): SLS4 function disabled.	27
SSMS	SSM output	OFF (0): The motor speed (output frequency) is higher than the SSM frequency. ON (1): The motor speed (output frequency) is equal to or lower than the SSM frequency.	29
SBCS ^{*2}	SBC monitor output	OFF (1): The brake is applied. ON (0): The brake is released.	31

*1 The value "0" or "1" in the parentheses is the bit value.

*2 The signal is used for monitoring. It is not used for controlling the brake.

4.2 Input terminals (Safety communication model only)

Use the following safety parameters to select or change functions of terminals SX1 and SX2.

Pr.	Name	Initial value	Setting range	Description
S051	SX1/SX2 terminal function selection	0	0, 6	0: No function 6: Brake feedback (SBCFB) signal
S061	SX1/SX2 terminal filtering time	0.01 s	0.01 to 0.1 s	Set the time from when the signal is input until the inverter starts actual operation.
S066	SX1/SX2 terminal mismatch permissible time	0.2 s	0 to 2 s	Set a mismatch permissible time for redundant input signals. Setting "0" disables detection of the input mismatch fault.

◆ Redundant input wiring

- Signals having the same function are input via terminals SX1 and SX2 with double wiring redundancy. The inverter constantly verifies that the ON/OFF logic of the two input signals are consistent with each other to detect input faults. Use **Pr.S066** to set a time period during which a mismatch between the two input signals is allowed.
- When the two signals are still inconsistent for the time period set in **Pr.S066** or longer, "E.SAF" (fault detail code 54) is displayed. The following diagram shows an example of input mismatch fault detection.

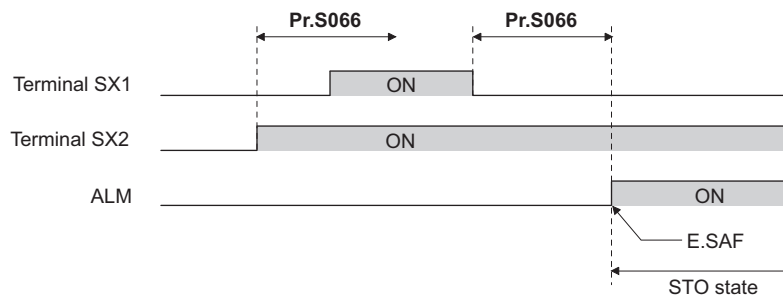

◆ Self-diagnosis with test pulse signals

- Fault diagnosis of the input circuit is performed while the input signals are ON by inputting test pulse signals to temporarily turn OFF the input signals.
- When a fault is detected, "E.SAF" (fault detail code 49) is displayed.

◆ Input terminal filter

- This function enables setting a time period to eliminate noises of input signals or test pulses from external devices.
- Set the time from when the signal is input until the inverter starts actual operation in **Pr.S061**. When test pulse signals are superposed on input signals, consider the time required for turning OFF the test pulse signals.
- A longer filtering time is more effective for chattering prevention and noise elimination, but causes a delay in the response of input terminals.
- Refer to the following table to set the filtering time.

Configuration		Filtering time
Including switches or other devices without diagnosis function		4 ms or more
Including devices with diagnosis function	Test pulse signals superposed on device output signals	Time required for turning OFF device test pulse signals plus 4 ms or more
	Test pulse signals not superposed on device output signals	4 ms or more

NOTE

- **Pr.699 Input terminal filter** is not applicable to terminals SX1 and SX2.

◆ Input terminal response time

- The input terminal response time changes according to the filtering time.

ON→OFF: Filtering time + 30 ms or less

OFF→ON: Filtering time + 50 ms or less

4.3 Output terminals (Safety communication model only)

Use the following safety parameters to select or change functions of terminals SY1 and SY2.

When functions are assigned to terminals SY1 and SY2, set **Pr.S070 SY1/SY2 terminal test pulse diagnosis execution selection** and **Pr.S071 SY1/SY2 terminal test pulse off time** to perform fault diagnosis with test pulse signals.

Pr.	Name	Initial value	Setting range	Description
S055	SY1/SY2 terminal function selection	0	0, 1	0: No function 1: SBC output (SBC) signal
S070	SY1/SY2 terminal test pulse diagnosis execution selection	0	0 1	Diagnosis disabled. Diagnosis enabled.
S071	SY1/SY2 terminal test pulse off time	0	0 1	2 ms 4 ms

◆ Redundant output wiring

- By outputting signals having the same function via terminals SY1 and SY2, the function assigned to the terminals remains effective when a fault occurs for one of the terminals.

◆ Self-diagnosis with test pulse signals

- While the output signals are ON, fault diagnosis of the output circuit (including external devices) is performed by outputting test pulse signals to temporarily turn OFF the output signals.
- To perform fault diagnosis with test pulse signals, set **Pr.S070** = "1".
- Test pulse signals are output at fixed intervals for terminals SY1 and SY2 while the signals assigned to the terminals are ON. Test pulse signals are output for terminals SY1 and SY2 at different timings. Use **Pr.S071** to set a time period during which the signal is turned OFF by the test pulse signal. Set the time period so that external devices are not affected by output of test pulse signals.
- When a fault is detected, "E.SAF" (fault detail code 61) is displayed.

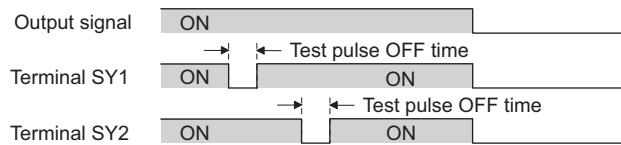

◆ Output terminal response time

- 30 ms or less

5 Safety Sub-Functions

5.1 STO function

The inverter output is shut off when the command signal is input from an external device or when the protective function (E.SAF) is activated.

◆ Basic operation

- The STO function is activated by turning OFF the STO command (STOC) signal.
- While the STO function is active, the inverter is in the STO state and the output is shut off.
- In the STO state, the STO output (STOS) signal turns OFF.
- The STO state is cleared by turning ON the STOC signal.

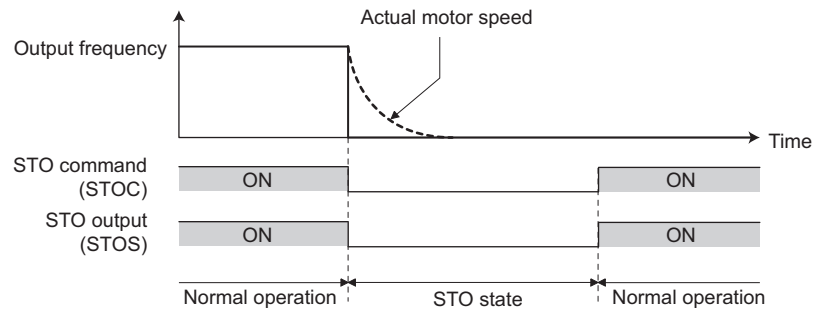

NOTE

- When the protective function (E.SAF) is activated, the inverter output is shut off by the STO function regardless of the STOC signal status.

5.2 SS1 function

This function is used to activate the STO function after a specified time.

Pr.	Name	Initial value	Setting range	Description
S004	SS1 deceleration monitoring time	5 s	0 to 3600 s	Set the time from when the SS1 function is activated until the STO function is activated.

◆ Basic operation

- The SS1 function is activated by turning OFF the SS1 command (SS1C) signal.
- When the SS1 function is enabled, the SS1 output (SS1S) signal turns OFF.
- The STO function is activated when the time set in **Pr.S004** elapses after the SS1 function is activated.
- The STO state is cleared by turning ON the SS1C signal.

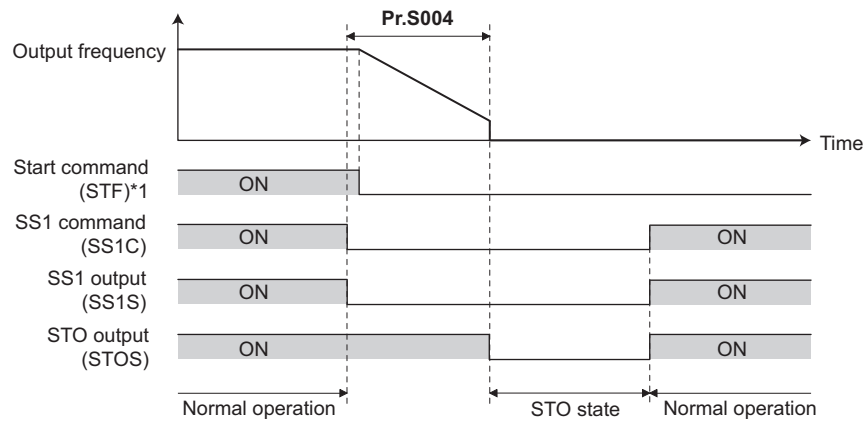

*1 The start command is not automatically changed by the safety sub-function.

NOTE

- When the STO command (STOC) signal is turned OFF before the time set in **Pr.S004** elapses, the STO state is activated immediately. The STO state is kept while either of the STOC signal or the SS1C signal is OFF. The STO state is cleared when both signals are turned ON.
- When the SS1C signal is turned OFF in advance, the STO state is activated immediately by power reset or inverter reset. (The setting in **Pr.S004 SS1 deceleration monitoring time** is disabled.)

5.3 SLS function

This function is used to activate the STO function after a specified time when the motor speed (output frequency) exceeds a specified limit.

Four operation patterns can be selected by setting different limits using SLS1 to SLS4 functions.

To use this function, specifications and operating conditions of motor speed estimation must be satisfied. (Refer to [page 8](#).)

Pr.	Name	Initial value	Setting range	Description
S001 ^{*1}	Monitoring speed selection	0	0	Speed monitoring is disabled.
			1	Monitoring is enabled using the estimated speed.
S005	SLS mode selection	0	0	The frequency command is not changed automatically when the SLS function is activated.
			1	The frequency command is changed automatically when the SLS function is activated.
S006	SLS frequency 1	6 Hz	0 to 60 Hz	Set the level to detect the overspeed.
S007	SLS frequency 2	6 Hz	0 to 60 Hz	
S008	SLS frequency 3	6 Hz	0 to 60 Hz	
S009	SLS frequency 4	6 Hz	0 to 60 Hz	
S010	SLS deceleration monitoring time 1	5 s	0 to 3600 s	Set the time from when the SLS function is activated until speed monitoring is started.
S011	SLS deceleration monitoring time 2	5 s	0 to 3600 s	
S012	SLS deceleration monitoring time 3	5 s	0 to 3600 s	
S013	SLS deceleration monitoring time 4	5 s	0 to 3600 s	
S014	SLS operation frequency 1	3 Hz	0 to 60 Hz	When Pr.S005 = "1", set the frequency command used when the SLS function is activated. Set a value smaller than the corresponding SLS frequency (Pr.S006 to Pr.S009).
S015	SLS operation frequency 2	3 Hz	0 to 60 Hz	
S016	SLS operation frequency 3	3 Hz	0 to 60 Hz	
S017	SLS operation frequency 4	3 Hz	0 to 60 Hz	
S018	SLS speed detection delay time	0 s	0 to 60 s	Set the time from when the motor speed exceeds the overspeed judgment level until the STO function is activated.

*1 To use the SLS function, set **Pr.S001** = "1". When the SLS function is activated while **Pr.S001** = "0 (initial value)", "E.SAF" (fault detail code 71) is displayed.

◆ Basic operation

The following shows the operation example when only the SLS1 function is activated (**Pr.S005** = "0 (initial value)").

- The SLS1 function is activated by turning OFF the SLS1 command (SLS1C) signal.
- Speed monitoring is started when the time set in **Pr.S010** elapses after the SLS1 function is activated.
- When the motor speed exceeds the **Pr.S006** setting, counting of the overspeed time is started. The overspeed time is cleared when the speed is decreased to the **Pr.S006** setting or lower.
- When the overspeed time reaches the **Pr.S018** setting, "E.SAF" (fault detail code 72) is displayed and the STO function is activated.
- When the SLS1C signal is turned ON, the SLS1 function is terminated.

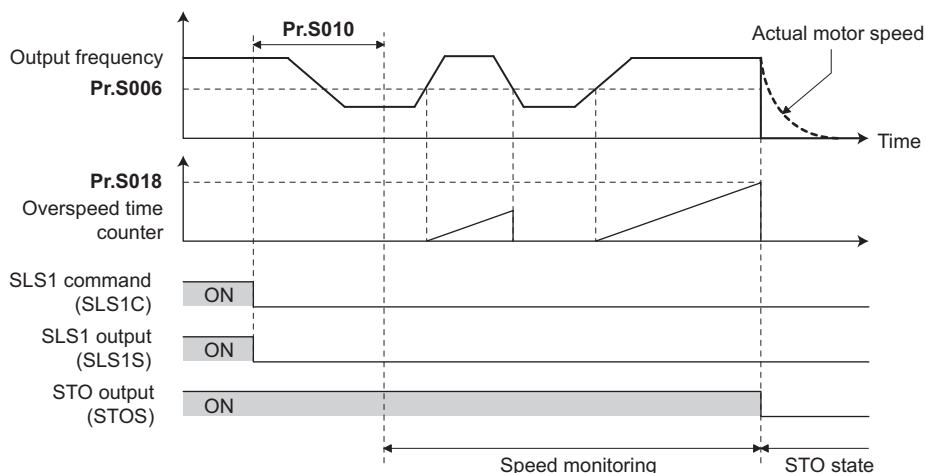

◆ Changing the frequency command automatically when the SLS function is activated (Pr.S005 = "1")

The following shows the operation example when only the SLS1 function is activated (Pr.S005 = "1").

- When Pr.S005 = "1", the frequency command is changed to the value set in Pr.S014 after the SLS1 function is activated.

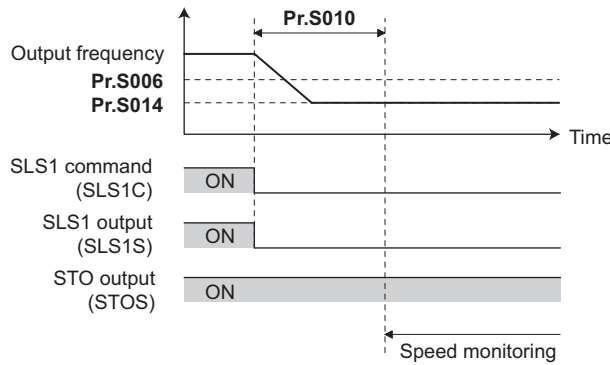

NOTE

- The priority of the frequency commands given by the external signals is as follows: SLS function > JOG operation > multi-speed operation > terminal 4 analog input > terminal 2 analog input.
- The maximum frequency settings in Pr.1 and Pr.18 are valid, and the minimum frequency setting in Pr.2 is invalid.

◆ Activating more than one SLS function

The following shows the operation example when the SLS1 function and the SLS2 function are activated (Pr.S005 = "1").

- When multiple SLS command signals are used, corresponding SLS functions are activated by turning OFF the command signals.
- When Pr.S005 = "1", the frequency command is changed to the smallest valid value after the SLS functions are activated.

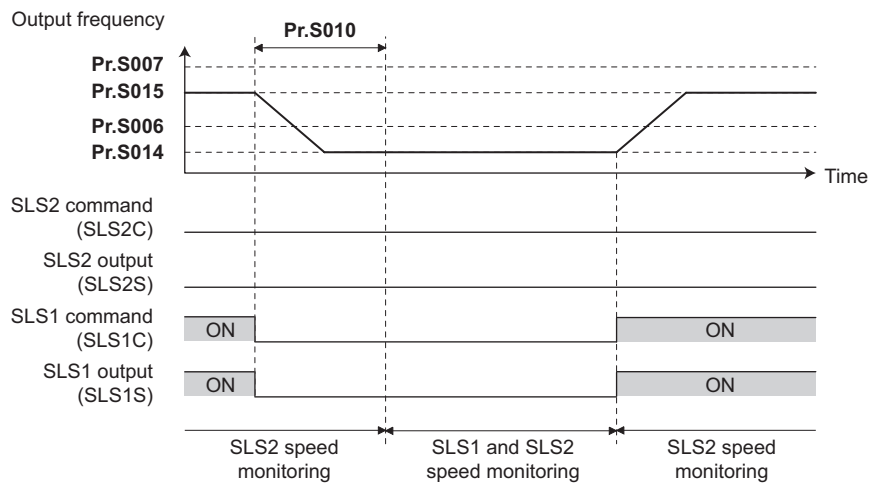

NOTE

- For the CC-Link IE TSN safety communication function and CIP Safety, four operation patterns can be activated at the same time.
- For PROFIsafe, four patterns can be set but cannot be activated at the same time. (Refer to [page 43.](#))

5.4 SSM function

This function is used to determine that the motor speed (output frequency) has exceeded the specified value.

To use this function, specifications and operating conditions of motor speed estimation must be satisfied. (Refer to [page 8.](#))

Pr.	Name	Initial value	Setting range	Description
S001 ^{*1}	Monitoring speed selection	0	0	Speed monitoring is disabled.
			1	Monitoring is enabled using the estimated speed.
S019 ^{*2}	SSM frequency	6 Hz	0 to 60 Hz	Set the level to detect the overspeed.
S020	SSM hysteresis width	5 Hz	0 to 15 Hz	Set the hysteresis width for the overspeed judgment level. The lower limit is calculated by the following: (Pr.S019 - Pr.S020). When the Pr.S020 setting is larger than the Pr.S019 setting, the lower limit is 0 Hz.
S021	SSM output retention time	0 s	0 to 3600 s	Set the time period to retain the SSM output (SSMS) signal status immediately before the STO function is activated.

*1 To use the SSM function, set Pr.S001 = "1". When the SSM function is activated while Pr.S001 = "0 (initial value)", "E.SAF" (fault detail code 71) is displayed.

*2 When Pr.S019 = "0", the SSMS signal remains ON while the inverter is stopped, and remains OFF during operation.

5

◆ Basic operation

- Speed monitoring is started by turning OFF the SSM command (SSMC) signal.
- When the motor speed is equal to or less than the Pr.S019 setting, the SSM output (SSMS) signal turns ON.
- The SSMS signal turns OFF when the motor speed exceeds the Pr.S019 setting.
- The SSMS signal turns ON when the motor speed decreases to be equal to or less than the value calculated by the following: (Pr.S019 - Pr.S020).
- Speed monitoring is terminated by turning ON the SSMC signal.

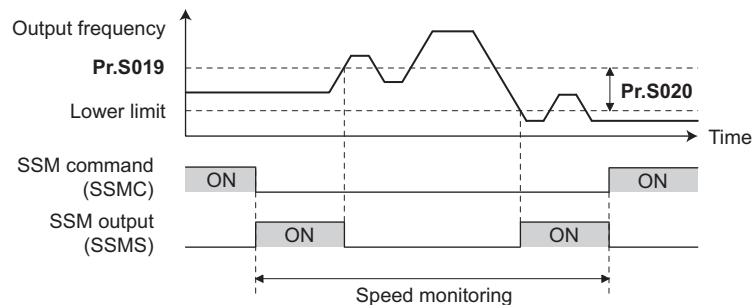

NOTE

- While the SSMC signal is ON, the SSMS signal remains OFF regardless of the motor speed.

◆ SSM output retention time (Pr.S021)

- The SSMS signal status immediately before the STO function is activated is retained for the time period set in **Pr.S021**.

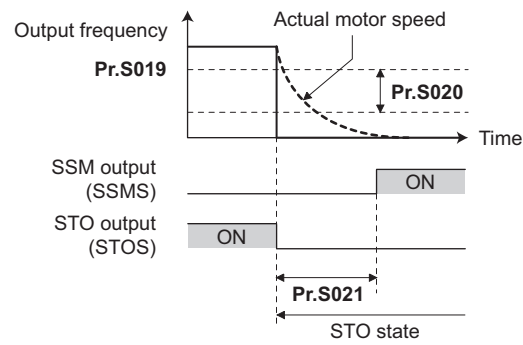

NOTE

- The SSM output is not retained when the output is shutoff by the protective function or a function other than the STO function (for example, MRS signal input).

5.5 SBC function (Safety communication model only)

This function controls activation or release of the mechanical brake in conjunction with the STO function operation activated by the STO or SS1 command input. (For details of the STO and SS1 functions, refer to [page 25](#) and [page 26](#).)

When **Pr.S023 SBC brake operation frequency** ≠ "0", specifications and operating conditions of motor speed estimation must be satisfied. (Refer to [page 8](#).)

Pr.	Name	Initial value	Setting range	Description
S001 ^{*1}	Monitoring speed selection	0	0	Speed monitoring is disabled.
			1	Monitoring is enabled using the estimated speed.
S004	SS1 deceleration monitoring time	5 s	0 to 3600 s	Set the time from when the SS1 function is activated until the STO function is activated. When Pr.S024 is set, the time set in this parameter is used as the time from when the SS1 function is activated until the brake is activated.
S023 ^{*1}	SBC brake operation frequency	0 Hz	0 to 30 Hz	The brake is activated when the motor speed is decreased to the value set in this parameter or lower before the time set in Pr.S004 elapses after the SS1 function is activated. This function is disabled when "0" is set in the parameter.
S024 ^{*2}	SBC output shutoff delay time	0.3 s	0 to 5 s	Set the time from when the brake is activated until the STO function is activated.
S025 ^{*2}	SBC brake release delay time	0.3 s	0 to 5 s	Set the time from when the STO state is cleared until the brake is released.
S026	SBC FB input selection	0	0, 1	Select the logic of the Brake feedback (SBCFB) signal for normal brake operation. The brake feedback signal diagnosis is performed based on the selected logic (normal condition). ^{*3} 0: OFF (brake operating), ON (brake released) 1: ON (brake operating), OFF (brake released)
S027	SBC mismatch detection time	2 s	0 to 5 s	Set the time until the fault is determined for the brake feedback signal diagnosis.
S051 ^{*4}	SX1/SX2 terminal function selection	0	0, 6	To use the SBC function, set Pr.S051 = "6" to assign the SBCFB signal.
S055 ^{*4}	SY1/SY2 terminal function selection	0	0, 1	To use the SBC function, set Pr.S055 = "1" to assign the SBC output (SBC) signal. ^{*5}

*1 When **Pr.S023** ≠ "0", set **Pr.S001** = "1". When **Pr.S023** ≠ "0" and **Pr.S001** = "0 (initial value)", "E.SAF" (fault detail code 41) is displayed after next power-ON or inverter reset.

*2 Consider the mechanical delay time of the brake to set **Pr.S024** and **Pr.S025**.

*3 The terminal ON state shows that the terminal is conducted (the line is closed), and the OFF state shows that the terminal is not conducted (the line is open).

*4 If the SBCFB signal is not assigned to input terminals while the SBC signal is assigned to output terminals, "E.SAF" (fault detail code 41) is displayed after next power-ON or inverter reset.

*5 When functions are assigned to terminals SY1 and SY2, set **Pr.S070 SY1/SY2 terminal test pulse diagnosis execution selection** and **Pr.S071 SY1/SY2 terminal test pulse off time** to perform fault diagnosis with test pulse signals. (Refer to [page 24](#).)

◆ Basic operation

- The SBC output (SBC) signal turns OFF when the STO function is activated by the STO or SS1 command input.
- The brake is activated when the SBC signal is turned OFF.
- The SBC signal turns ON when the STO state is cleared by the STO or SS1 command input.
- The brake is released when the SBC signal is turned ON.
- The following shows the operation example when the STO function is activated by the SS1 command input.

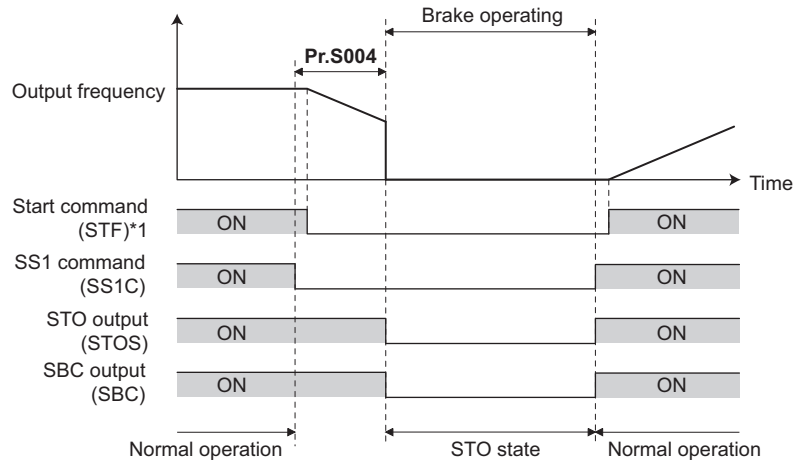

*1 The start command is not automatically changed by the safety sub-function.

NOTE

- Use a non-excitation type brake since the brake is activated when the SBC signal is turned OFF.
- The SBC function only controls power supply to the mechanical brake (relay operation), and it does not guarantee the brake operation including the condition without abrasion.
- The SBC function is not activated when the output is shutoff by the protective function other than E.SAF or a function other than the STO function (for example, MRS signal input).

◆ SBC brake operation frequency (Pr.S023)

The following shows the operation example when the STO function is activated by the SS1 command input.

- The brake operating conditions can be added by setting **Pr.S023**.
- The SBC signal is turned OFF when the motor speed is decreased to the value set in **Pr.S023** or lower before the time set in **Pr.S004** elapses after the SS1 function is activated. This function is disabled when **Pr.S023** = "0 (initial value)".

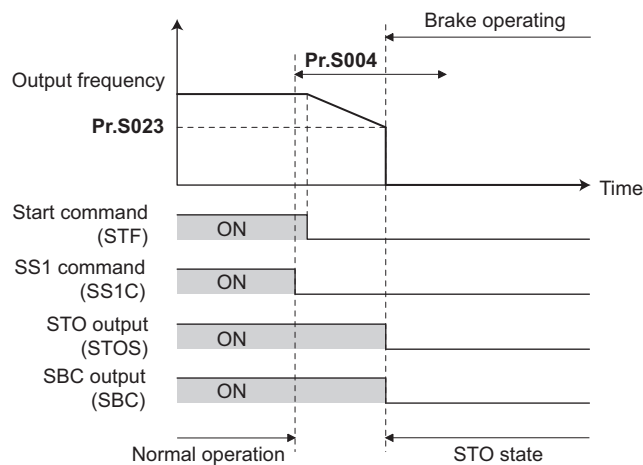

◆ SBC output shutoff delay time (Pr.S024)

The following shows the operation example when the STO function is activated by the SS1 command input.

- **Pr.S024** can be used to set a delay for the time from when the brake is activated until the STO function is activated.
- The STO function is activated when the time set in **Pr.S024** elapses after the brake is activated.

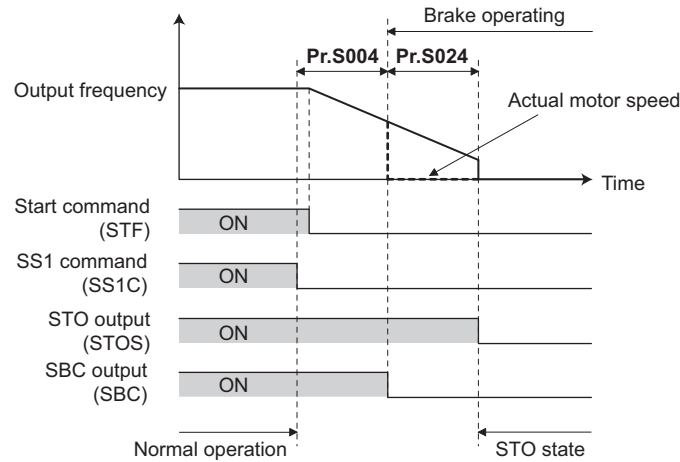

NOTE

- When the SS1C signal is turned OFF in advance, the STO state is activated immediately by power reset or inverter reset. (The settings in **Pr.S004 SS1 deceleration monitoring time** and **Pr.S024 SBC output shutoff delay time** are disabled.)
- When the output is shut off by the protective function (E.SAF), the **Pr.S024** setting is invalid.

◆ SBC brake release delay time (Pr.S025)

The following shows the operation example when the STO function is activated by the SS1 command input.

- **Pr.S025** can be used to set a delay for the time from when the STO state is cleared until the brake is released.
- The SBC signal turns ON when the time set in **Pr.S025** elapses after the STO state is cleared.

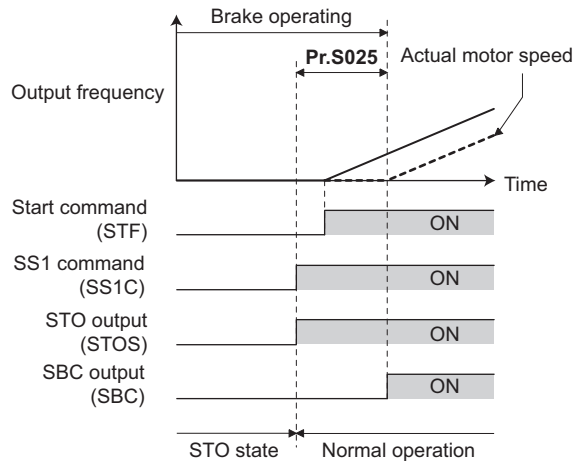

◆ Operation when the SBC output shutoff delay time (Pr.S024) and SBC brake release delay time (Pr.S025) are set

■ Activating the STO function before the time set in Pr.S025 elapses

The following shows the operation example when the STO function is activated by the STO command input.

- The STO state is activated immediately by turning OFF the STOC signal before the time set in **Pr.S025** elapses after the STO state is cleared regardless of the **Pr.S024** setting.

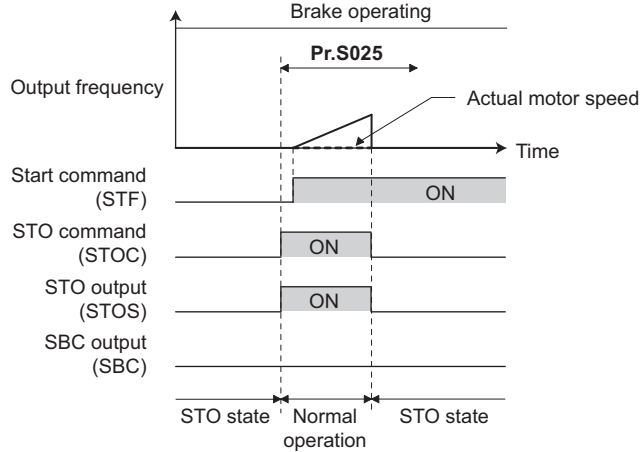

■ Clearing the STO function before the time set in Pr.S024 elapses

The following shows the operation example when the STO function is activated by the SS1 command input.

- When the SS1C signal is turned ON before the time set in **Pr.S024** elapses, the STO state is not activated. However, the SBC signal turns ON when the time set in **Pr.S025** elapses after the SS1C signal is turned ON.

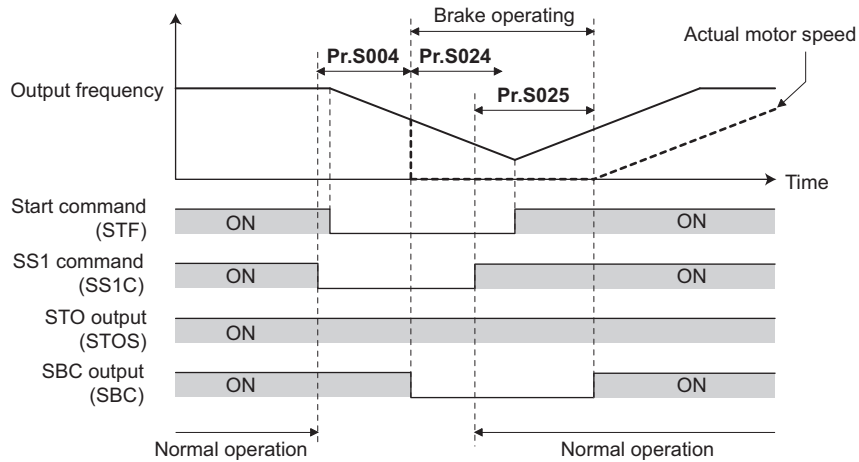

◆ Diagnosis using the Brake feedback (SBCFB) signal

- The brake status can be checked by the Brake feedback (SBCFB) signal. This function is always active while the SBC function is enabled.
- The status of the SBC signal and the SBCFB signal are monitored, and "E.SAF" (fault detail code 76) is displayed when the signal status is different from the one shown in the following table for the time longer than the time set in **Pr.S027**.

SBC signal	SBCFB signal		Brake status
	Pr.S026 = "0 (initial value)"	Pr.S026 = "1"	
OFF	OFF	ON	Operating
ON	ON	OFF	Released

NOTE

- When functions are assigned to terminals SY1 and SY2, set **Pr.S070 SY1/SY2 terminal test pulse diagnosis execution selection** and **Pr.S071 SY1/SY2 terminal test pulse off time** to perform fault diagnosis with test pulse signals. (Refer to [page 24](#).)

6 Safety Communication Functions

6.1 CC-Link IE TSN safety communication functions

6.1.1 Overview

CC-Link IE TSN safety communication functions are supported as the CC-Link IE TSN application.

Input and output signals for safety sub-functions can be controlled using CC-Link IE TSN safety communication functions.

◆ Term

The following table describes terms used in this Instruction Manual related to the safety communication and CC-Link IE TSN safety communication functions.

Term	Description
Safety communication	Communication performed with all necessary measures included to guarantee safe data transmission according to the requirements of IEC 61508
Standard communication	Communication other than the safety communication (cyclic transmission and transient transmission of CC-Link IE TSN)
Remote station	A station that transmits I/O bit signals and I/O word data by cyclic transmission. It also supports transient transmission. It does not support safety communication functions.
Remote station (safety station)	A station that transmits I/O bit signals by safety communication. It supports safety communication functions.

◆ Communication specifications

The communication specifications are shown in the following table.

Item	Description	
Communication method	Connecting type	
Maximum number of safety connections for one station	1	
Safety remote I/O	SA#X	32 bits
	SA#Y	32 bits
Safety remote station refresh response processing time (SRref)	64 ms	

◆ Safety communication error detection

When a communication error is detected by a CC-Link IE TSN safety communication function, "E.SAF" (fault detail code 69) is displayed and the inverter output is shut off. This function is activated regardless of the settings of **Pr.500 Communication error execution waiting time** and **Pr.502 Stop mode selection at communication error**.

◆ Additional remote I/O signals for CC-Link IE TSN safety communication functions

In addition to the remote I/O signals and remote devices compatible with CC-Link IE TSN, the following safety remote I/O signals are supported for CC-Link IE TSN safety communication functions.

Item	Description
Safety remote input (SA#X)	Safety input signal from the inverter to the master/local module
Safety remote output (SA#Y)	Safety output signal from the master/local module to the inverter

◆ Communication status LEDs

The network status LEDs are equivalent to CC-Link IE TSN. Refer to the FR-E800 Instruction Manual (Communication).

■ Precautions for status LEDs

Communication status LEDs are not provided as included in the safety system. LED status may not be always correct. Do not use them as operation indicators. They are used only to check the status for test operation and during troubleshooting.

6.1.2 Setting procedure for CC-Link IE TSN safety communication functions

The following section describes settings for CC-Link IE TSN safety communication functions.

◆ Settings for CC-Link IE TSN

Refer to the FR-E800 Instruction Manual (Communication).

◆ Enabling CC-Link IE TSN safety communication functions

Set "1" in **Pr.S002 Safety communication function selection** to enable CC-Link IE TSN safety communication functions.

Refer to details of safety parameters (page 16).

NOTE

- CC-Link IE TSN safety communication functions are not affected by the IP address specification for Ethernet command source selection (**Pr.1449 to Pr.1454**).

◆ Setting parameters for safety sub-functions

Configure settings for safety sub-functions to be used.

Refer to details of safety parameters (page 16).

◆ Safety communication settings using engineering software

1. Use FR Configurator2 to set safety parameters **Pr.S030 to Pr.S032**.
For details, refer to the Master Module User's Manual.

Pr.	Name	Initial value	Setting range
S030	CC-Link IE TSN safety communication function - Transmission interval monitoring time ^{*1}	128 ms	128 to 1000 ms
S031	CC-Link IE TSN safety communication function - Safety certification code (upper) ^{*2}	65535	0 to 65535
S032	CC-Link IE TSN safety communication function - Safety certification code (lower) ^{*2}	65535	0 to 65535

*1 Transmission interval (remote station) for monitoring by the safety programmable controller to detect safety communication faults.
(128 ms = Safety remote station refresh response processing time (SRref) × 2, SRref = 64 ms)

*2 Code used for certification of a device when it is connected to the safety programmable controller.

- On GX Works3, select "Basic Settings">"Safety Communication Setting" and enable the use of safety communication. Click the detailed setting field for "Safety Communication Setting".

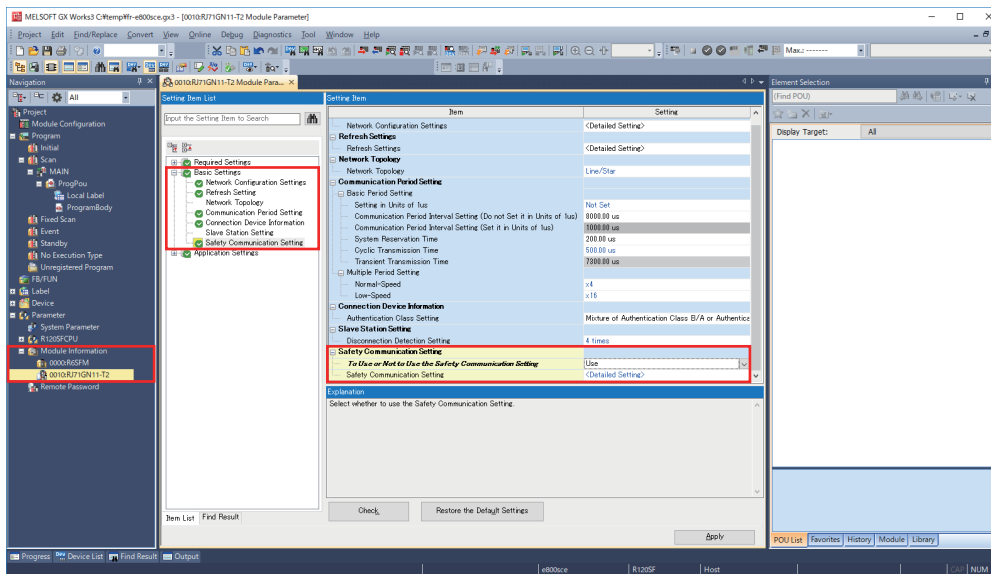

- Selecting "Local Network" as "Communication Destination" in the "Safety Communication Setting" window displays "Select the target module for the Safety Communication Setting" window. Click on the checkbox of the inverter and click the [Add] button.

Safety Communication Setting

No.	Communication Destination	Network Configuration			Configured Module			
		Network No.	Station No.	IP Address	Station Type	Model Name	Communication Destination	PLC No.
1								
2								
3								
4								

Select the target module for the Safety Communication Setting

Select the target module for the safety communication setting in the local network.
 (Caution)
 - The value will be overwritten if the setting for the same IP address and station No. have already existed.
 - Please set the Network Configuration Settings to set safety communication setting for the local network.

Select All [A] Reset All [R]

Station No.	IP Address	Station Type	Number of Connections	Model Name
<input checked="" type="checkbox"/>	192.168.50.1	Remote Station	1	FR-E800-SCE

Add Cancel

4. Set "Sending Interval Monitoring Time", "Safety Refresh Monitoring Time", "Safety Data Transfer Device Setting", and "Safety Authentication Code" and click the [OK] button.
For details, refer to the Master Module User's Manual.

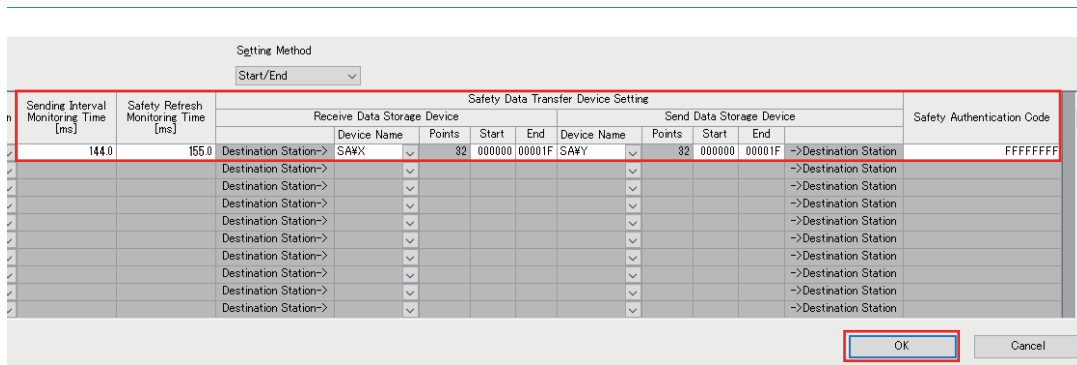

Setting example for the transmission interval monitoring time (master station)

144 ms = Transmission interval monitoring time (remote station) + (Communication cycle intervals (LS) × 2)

- Transmission interval monitoring time (remote station) = 128 ms
- LS = 8 ms

Setting example for the safety refresh monitoring time

155 ms = Transmission interval monitoring time (master station) + (Transmission interval monitoring time (remote station) / 2) + (Communication cycle intervals (LS) × 2) - a

- Transmission interval monitoring time (master station) = 144 ms
- Transmission interval monitoring time (remote station) = 128 ms
- LS = 8 ms
- a = Transmission interval monitoring time (master station) - b = 69 ms
- b = A smallest multiple of safety cycle time which is greater than a half of the transmission interval monitoring time (master station) = 75 ms
- Safety cycle time = 5 ms

Setting example for the safety authentication code

Set the same value in FR Configurator2 and GX Works3. When the values are inconsistent, connection using safety communication is not enabled.

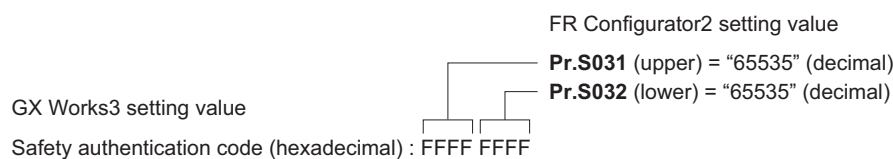

5. Write unit parameters to the CPU module.

6. Reset the CPU module.

6.1.3 Safety remote I/O

The following safety remote input and output devices are supported.

◆ Safety remote output (from the master module to the inverter)

Output signals from the master module are as follows. (Input signals to the inverter)

Device No. ^{*1}	Signal name	Description ^{*2}
SA#Yn0	STOC (STO command)	OFF (0): STO function enabled. ON (1): STO function disabled.
SA#Yn1	SS1C (SS1 command)	OFF (0): SS1 function enabled. ON (1): SS1 function disabled.
SA#Yn2	-	Not used (fixed to "0")
SA#Yn3	SSMC (SSM command)	OFF (0): SSM function enabled. ON (1): SSM function disabled.
SA#Yn4 to Yn7	-	Not used (fixed to "0")
SA#Yn8	SLS1C (SLS1 command)	OFF (0): SLS1 function enabled. ON (1): SLS1 function disabled.
SA#Yn9	SLS2C (SLS2 command)	OFF (0): SLS2 function enabled. ON (1): SLS2 function disabled.
SA#YnA	SLS3C (SLS3 command)	OFF (0): SLS3 function enabled. ON (1): SLS3 function disabled.
SA#YnB	SLS4C (SLS4 command)	OFF (0): SLS4 function enabled. ON (1): SLS4 function disabled.
SA#YnC to YnF	-	Not used (fixed to "0")
SA#Y(n+1)0 to Y(n+1)F	-	Not used (fixed to "0")

*1 "n" indicates a value determined by the station number.

*2 The value "0" or "1" in the parentheses is the bit value.

◆ Safety remote input (from the inverter to the master module)

Input signals to the master module are as follows. (Output signals from the inverter)

Device No. ^{*1}	Signal name	Description ^{*2}
SA#Xn0	STOS (STO output)	OFF (1): STO function enabled. ON (0): STO function disabled.
SA#Xn1	SSMS (SSM output)	OFF (0): The motor speed (output frequency) is higher than the SSM frequency. ON (1): The motor speed (output frequency) is equal to or lower than the SSM frequency.
SA#Xn2 to Xn7	-	Not used (fixed to "0")
SA#Xn8	SLS1S (SLS1 output)	OFF (1): SLS1 function enabled. ON (0): SLS1 function disabled.
SA#Xn9	SLS2S (SLS2 output)	OFF (1): SLS2 function enabled. ON (0): SLS2 function disabled.
SA#XnA	SLS3S (SLS3 output)	OFF (1): SLS3 function enabled. ON (0): SLS3 function disabled.
SA#XnB	SLS4S (SLS4 output)	OFF (1): SLS4 function enabled. ON (0): SLS4 function disabled.
SA#XnC	SS1S (SS1 output)	OFF (1): SS1 function enabled. ON (0): SS1 function disabled.
SA#XnD to XnF	-	Not used (fixed to "0")
SA#X(n+1)0, X(n+1)1	-	Not used (fixed to "0")
SA#X(n+1)2	SBCS (SBC monitor output) ^{*3}	OFF (1): The brake is operating. ON (0): The brake is released.
SA#X(n+1)3 to X(n+1)F	-	Not used (fixed to "0")

*1 "n" indicates a value determined by the station number.

*2 The value "0" or "1" in the parentheses is the bit value.

*3 The signal is used for monitoring. It is not used for controlling the brake.

6.2 PROFIsafe

6.2.1 Overview

This communication is available only for the FR-E800-SCEPB and FR-E806-SCEPB. PROFIsafe is supported as the PROFINET application. Input and output signals for safety sub-functions can be controlled using PROFIsafe.

◆ Communication specifications

The communication specifications are shown in the following table.

Item	Description
PROFIsafe communication specifications	F-Device PROFIsafe_V2 functionality XP on PROFINET IO

◆ Safety communication error detection

When a communication error is detected by PROFIsafe, "E.SAF" (fault detail code 69) is displayed and the inverter output is shut off. This function is activated regardless of the setting of **Pr.502 Stop mode selection at communication error**.

◆ Additional Data Exchange for the PROFIsafe

In addition to Data Exchange types supported by PROFINET, the following Data Exchange types are supported by PROFIsafe.

No.	Type	Description
1	Process Data (Cyclic Data Exchange)	Standard Telegram 31 (PROFIdrive compliant)
2	Drive Profile Parameters (Acyclic Data Exchange)	P60022: PROFIdrive PROFIsafe telegram selection P60044: Fault message counter P60047: Fault number

◆ Communication status LEDs

The network status LEDs are equivalent to PROFINET. Refer to the FR-E800 Instruction Manual (Communication).

■ Precautions for status LEDs

Communication status LEDs are not provided as included in the safety system. LED status may not be always correct. Do not use them as operation indicators. They are used only to check the status for test operation and during troubleshooting.

6.2.2 Setting procedure for PROFI-safe

The following section describes settings for PROFI-safe.

◆ Settings for PROFINET

Refer to the FR-E800 Instruction Manual (Communication).

◆ Enabling PROFI-safe

Set "3" in **Pr.S002 Safety communication function selection** to enable PROFI-safe.

Refer to details of safety parameters ([page 16](#)).

NOTE

- PROFI-safe is not affected by the IP address specification for Ethernet command source selection (**Pr.1449 to Pr.1454**).

◆ Setting parameters for safety sub-functions

Configure settings for safety sub-functions to be used.

Refer to details of safety parameters ([page 16](#)).

◆ PROFI-safe communication connection settings

1. Set the PROFI-safe destination address (F_Dest_Add) using the engineering software of the master.
2. Set the same value as the PROFI-safe destination address (F_Dest_Add) in the safety parameter **Pr.S089 PROFI-safe address** using FR Configurator2.

◆ Communication error detection settings

Use the engineering software of the master to configure settings for communication error detection.

Parameter	Description
Watchdog time (F_WD_Time)	1500 ms to 10000 ms A timeout error occurs when the time set in the parameter elapses.

6.2.3 Data Exchange

The following section describes Data Exchange types added for PROFIsafe in addition to those supported by PROFINET. For details of Data Exchange types supported by PROFINET, refer to the FR-E800 Instruction Manual (Communication).

◆ Process Data (Cyclic Data Exchange)

Input and output signals for safety sub-functions can be controlled using PROFIsafe Telegram.

Use slots to assign it with the PROFIdrive Telegram.

For details of PROFIdrive Telegram, refer to the FR-E800 Instruction Manual (Communication).

Telegram	Name	Description
31	Standard Telegram 31	For the functional safety control application

■ Standard Telegram 31

Direction	IO Data number	Name	Abbreviation	Data length (bit)	Remarks
Controller to drive	1	Safety control word 2	S_STW2	32	PROFIsafe-user data
	2				
Drive to controller	1	Safety status word 2	S_ZSW2	32	PROFIsafe-user data
	2				

- Details of the Safety control word (S_STW2)

Byte	Bit	Definition of bit	Inverter operation ^{*1}
0	0	STO No Safe Torque Off / Safe Torque Off	OFF (0): STO function enabled. ON (1): STO function disabled.
0	1	SS1 No Safe Stop 1 / Safe Stop 1	OFF (0): SS1 function enabled. ON (1): SS1 function disabled.
0	2, 3	-	Not used (fixed to "0")
0	4	SLS No Safe Limited Speed / Safe Limited Speed	OFF (0): SLS function enabled. ON (1): SLS function disabled.
0	5, 6	-	Not used (fixed to "0")
0	7	INTERNAL_EVENT_ACK Safety fault buffer error clear Safety Fault Acknowledge (1→0)	When 20 ms or more elapses after the bit is turned OFF, the safety fault buffer is cleared (the inverter fault is not cleared).
1	0	-	Not used (fixed to "0")
1	1	SLS_LIMIT_BIT0 Bit 0 for selection of SLS speed limit value	The SLS function to be enabled is selected by the bit value combination. [Bit1, Bit0] [0, 0]: SLS1 [0, 1]: SLS2 [1, 0]: SLS3 [1, 1]: SLS4
1	2	SLS_LIMIT_BIT1 Bit 1 for selection of SLS speed limit value	
1	3 to 7	-	Not used (fixed to "0")
2	0 to 7		
3	0	SSM (Device-specific)	OFF (0): SSM function enabled. ON (1): SSM function disabled.
3	1 to 7	-	Not used (fixed to "0")

*1 The value "0" or "1" in the parentheses is the bit value.

- Details of the Safety status word 2 (S_ZSW2)

Byte	Bit	Definition of bit	Inverter operation ^{*1}
0	0	POWER_REMOVED Safe Torque Off active / Safe Torque Off inactive (one-active)	OFF (1): STO function enabled. ON (0): STO function disabled.
0	1	SS1_ACTIVE Safe Stop 1 active / Safe Stop 1 inactive (one-active)	OFF (1): SS1 function enabled. ON (0): SS1 function disabled.
0	2, 3	-	Not used (fixed to "0")
0	4	SLS_ACTIVE Safe Limited Speed active / Safe Limited Speed inactive (one-active)	OFF (1): SLS function enabled. ON (0): SLS function disabled.
0	5, 6	-	Not used (fixed to "0")
0	7	INTERNAL_EVENT Safety Fault present / No Safety Fault	Used to notify that data is stored in the safety fault buffer. 0: No safety fault 1: Safety fault occurring
1	0	-	Not used (fixed to "0")
1	1	SLS_LIMIT_BIT0_ACTIVE Bit 0 of selected SLS speed limit value	The selected SLS function is shown by the bit value combination. [Bit1, Bit0] [0, 0]: SLS1 [0, 1]: SLS2 [1, 0]: SLS3 [1, 1]: SLS4
1	2	SLS_LIMIT_BIT1_ACTIVE Bit 1 of selected SLS speed limit value	
1	3 to 6	-	Not used (fixed to "0")
1	7	SSM Speed below limit value / Speed equal or above limit value	OFF (0): The motor speed (output frequency) is higher than the SSM frequency. ON (1): The motor speed (output frequency) is equal to or lower than the SSM frequency.
2	0 to 7	-	Not used (fixed to "0")
3	0 to 3		
3	4	SBCS (Device-specific) ^{*2}	OFF (1): The brake is operating. ON (0): The brake is released.
3	5 to 7	-	Not used (fixed to "0")

*1 The value "0" or "1" in the parentheses is the bit value.

*2 The signal is used for monitoring. It is not used for controlling the brake.

- STO state

In the STO state, the inverter transfers to "Switching ON inhibited" state.

◆ Drive Profile Parameters (Acyclic Data Exchange)

■ PROFIsafe parameters

PNU	Name	R/W	Data Type
P60022	PROFIdrive PROFIsafe telegram selection	R	Unsigned16
P60044	Fault message counter	R	Unsigned16
P60047	Fault number	R	Array [8] Unsigned16

- PROFIdrive PROFIsafe telegram selection (P60022)

PNU	Sub	Access	Name	Data Type	Description	Default
60022	0	R	Tgm selection	Unsigned16	The selected telegram is sent back.	31

PNU	Sub	Range	Units	EEP-ROM	Parameter
60022	0	0001h to FFFFh	-	Impossible	-

Details of the read values are as follows.

Value	Description
31	Standard telegram 31

- Fault message counter (P60044)

The value of Fault message counter is sent back. This value is incremented when the E.SAF fault occurs.

PNU	Sub	Access	Name	Data Type	Description	Default
60044	0	R	Fault counter	Unsigned16	-	0

PNU	Sub	Range	Units	EEP-ROM	Parameter
60044	0	0000h to FFFFh	-	Impossible	-

- Fault number (P60047)

Displays up to eight inverter fault detail codes for the faults which occurred after the power is turned ON. (Refer to [page 56](#) for the list of fault detail codes.)

While no E.SAF fault occurs, "0" is read for P60047.0 to 7.

PNU	Sub	Access	Name	Data Type	Description	Default
60047	0 to 7	R	Fault numbers	Array [8] Unsigned16	-	0

PNU	Sub	Range	Units	EEP-ROM	Parameter
60047	0 to 7	0000h to FFFFh	-	Impossible	-

- Safety fault buffer

Used to transmit fault detail codes from a device to the master.

The inverter status is stored as a fault detail code in the safety fault buffer.

Up to eight E.SAF fault detail codes which occurred after the power is turned ON are stored. When the ninth fault occurs, the eighth fault is overwritten by the new data.

PNU60047 is used to read fault detail codes, and PNU60044 is used to read the number of times the buffer is changed after the power is turned ON.

When a fault message is transmit to the safety fault buffer, it is transmitted to the master via S_ZSW2 (bit 7) and cleared after the master recognizes the fault (bit 7 of S_STW2 is cleared).

6.3 CIP Safety

6.3.1 Overview

This communication is available only for the FR-E800-SCEPA and FR-E806-SCEPA.

CIP Safety is supported as the EtherNet/IP application.

Input and output signals for safety sub-functions can be controlled using CIP Safety.

◆ Term

The following table describes terms used in this Instruction Manual related to the safety communication and the CIP Safety standard.

Term	Description
UNID	Unique Network Identifier (Unique Node Identifier) Unique ID used to identify a device on the network. It consists of SNN and Node Address. UNID is used when communication is established between the master and the inverter.
SNN	Safety Network Number Unique ID used to identify the relevant network in the entire network of the safety system.
Node Address	For CIP Safety, it refers to the IP address.
TUNID	Target UNID In this Instruction Manual, it refers to the UNID of the inverter.
OUNID	UNID of the master.
OCPUNID	UNID of the owner of the inverter's output connection. It refers to the OUNID in general.
CFUNID	UNID of the owner of the inverter's safety settings. It refers to the OUNID in general.
SCID	Safety Configuration ID Unique ID used to identify the setting data. It consists of SCCRC and SCTS. UNID is used when communication is established between the master and the inverter.
SCCRC	Safety Configuration CRC CRC of the safety setting value.
SCTS	Safety Configuration Time Stamp Time stamp of the time at which any safety setting is changed.
SNCT	Safety Network Configuration Tool In this Instruction Manual, it refers to the engineering software of the master.

◆ Communication specifications

The communication specifications are shown in the following table.

Item	Description
Safety I/O	RPI: Selected between 96 ms and 1000 ms as a multiple of 16. Number of concurrent connections: 4 (shared among Exclusive Owner, Input Only, Listen Only, Safety Input, and Safety Output) Connection type (inverter to master): Single-cast Connection type (master to inverter): Single-cast Supported format: Base Format, Extended Format
Safety Open type	Type 2a, Type 2b
Safety Open setting method	Use FR Configurator2 to set TUNID, OCPUNID, and SCID.
Conformity test	CT17-ES

◆ Safety communication error detection

When a communication error is detected by Safety I/O communication, "E.SAF" (fault detail code 69) is displayed and the inverter output is shut off. This function is activated regardless of the setting of **Pr.502 Stop mode selection at communication error**.

◆ Safety objects

In addition to the objects supported by EtherNet/IP, the following objects are supported for CIP Safety. These objects are accessed with Explicit message communication.

No.	Class	Object name
1	39h	Safety Supervisor Object
2	3Ah	Safety Validator Object

◆ Operation when a safety-related error occurs

When the E.SAF fault occurs (except when the fault detail code is 69), all Safety I/O communications stops.

◆ Communication status LEDs

The network status LED and the module status LED are used in accordance with the specifications of the CIP Safety standard.

■ Status LED description

- Network status LED

The network status LED indicates CIP safety communication status.

LED status	Description
OFF	The power is turned OFF or the IP address is not assigned.
Blinking green (500 ms)	The IP address is assigned, CIP connection is not established, and the Exclusive Owner connection has not timed out.
Solid green	The IP address is assigned, CIP connection is established, and the Exclusive Owner connection has not timed out.
Blinking red (500 ms)	The IP address is assigned and the Exclusive Owner connection has timed out.

- Module status LED

The module status LED indicates the status of the device.

LED status	Description
OFF	Power OFF
Solid green	Normal operation
Blinking green (500 ms)	The device is not set.
Blinking red (500 ms)	An alarm status (recoverable fault) is detected.
Solid red	A fault status (unrecoverable fault) is detected.
Blinking (green/red)	The device is performing a self-diagnosis function, or the TUNID setting or other setting is invalid.

■ Precautions for status LEDs

Communication status LEDs are not provided as included in the safety system. LED status may not be always correct. Do not use them as operation indicators. They are used only to check the status for test operation and during troubleshooting.

6.3.2 Setting procedure of CIP Safety

The following section describes settings for CIP Safety.

◆ Settings for EtherNet/IP

Refer to the FR-E800 Instruction Manual (Communication).

◆ Enabling CIP Safety

Set "2" in **Pr.S002 Safety communication function selection** to enable CIP Safety.

Refer to details of safety parameters ([page 16](#)).

NOTE

- Safety I/O communication is not affected by the IP address specification for Ethernet command source selection (**Pr.1449 to Pr.1454**).

◆ Setting parameters for safety sub-functions

Configure settings for safety sub-functions to be used.

Refer to details of safety parameters ([page 16](#)).

◆ CIP Safety communication connection settings

■ Configuring a safety network using SNCT

Set the SNN and IP address for the master and the inverter in the safety network configuration of SNCT.

■ Setting the UNID determined by SNCT in the inverter using FR Configurator2

1. Setting the TUNID (Pr.S135 to Pr.S139)

Enter the TUNID set and displayed in the SNCT safety network configuration in the inverter's relevant safety parameters.

Check the SNN and IP address of the inverter and enter the relevant values in the relevant safety parameters.

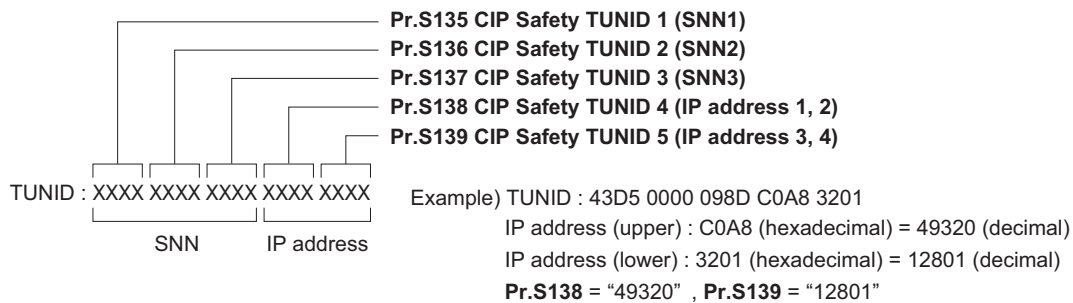

*1 The TUNID is set in hexadecimal. Convert the values to decimal values and set them in the safety parameters.

2. Setting the OCPUNID (Pr.S140 to Pr.S144)

Enter the OCPUNID set and displayed in the SNCT safety network configuration in the inverter's relevant safety parameters.

Check the SNN and IP address of the master and enter the relevant values in the relevant safety parameters.

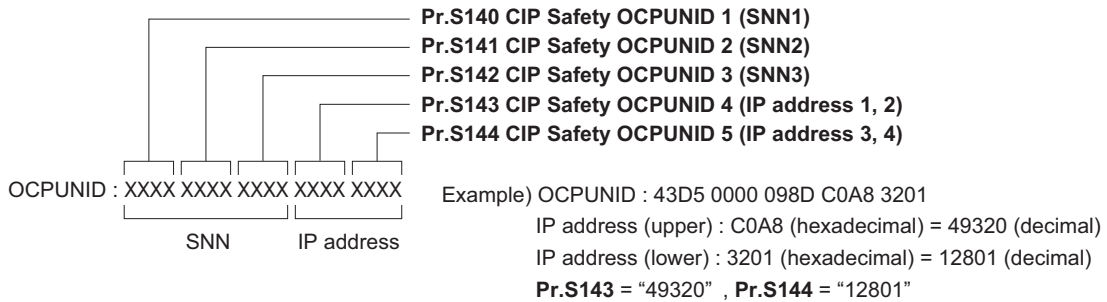

*1 The OCPUNID is set in hexadecimal. Convert the values to decimal values and set them in the safety parameters.

3. Perform parameter write.

■ Setting the inverter's SCID information in the SNCT safety network configuration

The inverter's SCID is issued by FR Configurator2.

The SCID is automatically written by performing batch write of safety parameters. (SCID safety parameters are read-only.)

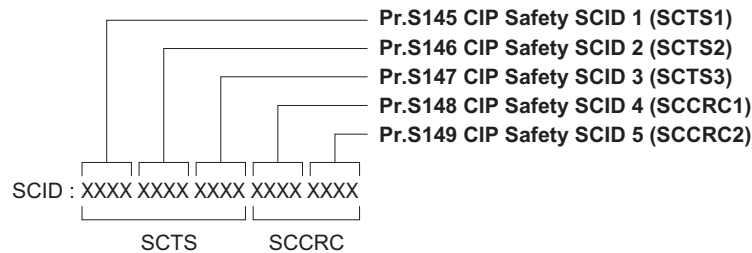

Enter the SCID displayed in FR Configurator2 in the SNCT safety network configuration.

After SCID information settings are completed, download the project data to the master.

NOTE

- When SCID = "0", the inverter's SCID is not checked by the master when connection is established. Before starting the system, check that an unintended value is not set in the inverter's SCID.
- When the safety parameter setting value is changed, SCID is also changed. In this case, change the safety network configuration and perform test operation again.

◆ Communication error detection settings

- Use SNCT to set the maximum permissible communication delay time (Network Time Expectation).

When a communication delay longer than the permissible communication delay time (Network Time Expectation) occurs during Safety I/O communication, the inverter output is shut off (safe state).

- Set the number of times to permit detection of a data fault (Max_Fault_Number) using SNCT.

When the communication error count in the past one hour reaches the number set in this parameter during Safety I/O communication, the inverter output is shut off (safe state).

Extended Format: Settable (initial value "5")

Base Format: Not settable (fixed to "1")

6.3.3 Object map

The following section describes objects added for CIP Safety in addition to those supported by EtherNet/IP. For details of objects supported by EtherNet/IP, refer to the FR-E800 Instruction Manual (Communication).

Object

Class ID	Object name
39h	Safety Supervisor Object
3Ah	Safety Validator Object

Instance, attribute

Object name	Instance No.	Attribute		FR-E800-E	FR-E800-SCE, FR-E806	Remarks
		No.	Name			
Assembly Object (04h)	140	3	Data	×	○	Safety Output
	190	3	Data	×	○	Safety Input
TCP/IP Interface Object (F5h)	1	7	Safety Network Number	×	○	The SNN is read.

◆ Identity Object (01h)

This object shows general information of the device.

■ Service

The execution condition of reset service differs.

FR-E800-E: No execution condition

FR-E800-SCE, FR-E806: Enabled only when I/O connection is not established.

■ Instance attribute

No.	Name	Value
3	Product code	003Fh
7	Product name	FR-E800-SCE

◆ Assembly Object (04h)

Input and output signals for safety sub-functions can be controlled using Safety I/O.

■ Service

Class	Instance
Get Attribute Single	Get Attribute Single Set Attribute Single

■ Class attribute

No.	Name	Access	Type	Value	Remarks
1	Revision	Get	UINT	0002h	Revision of the object
2	Max Instance	Get	UINT	-	Highest instance number

■ Instance attribute

No.	Name	Access	Type	Value	Remarks
3	Data	Get/Set	USINT array	-	Input/output data of inverter

■ Output assembly (from the master to the inverter)

- Instance 140 (8Ch): Safety Output

Byte	bit 7	bit 6	bit 5	bit 4	bit 3	bit 2	bit 1	bit 0
0	-	-	-	-	SSMC	-	SS1C	STOC
1	-	-	-	-	SLS4C	SLS3C	SLS2C	SLS1C
2	-	-	-	-	-	-	-	-
3	-	-	-	-	-	-	-	-

*1 Values input in the empty bits are invalid.

- Details of Safety Output

Signal name	Description ^{*1}
STOC	OFF (0): STO function enabled. ON (1): STO function disabled.
SS1C	OFF (0): SS1 function enabled. ON (1): SS1 function disabled.
SSMC	OFF (0): SSM function enabled. ON (1): SSM function disabled.
SLS1C	OFF (0): SLS1 function enabled. ON (1): SLS1 function disabled.
SLS2C	OFF (0): SLS2 function enabled. ON (1): SLS2 function disabled.
SLS3C	OFF (0): SLS3 function enabled. ON (1): SLS3 function disabled.
SLS4C	OFF (0): SLS4 function enabled. ON (1): SLS4 function disabled.

*1 The value "0" or "1" in the parentheses is the bit value.

*2 Set Attribute service for Attribute 3 Data of Instance 140 is not available.

■ Input assembly (from the inverter to the master)

- Instance 190 (BEh): Safety Input

Byte	bit 7	bit 6	bit 5	bit 4	bit 3	bit 2	bit 1	bit 0
0	-	-	-	-	-	-	SSMS	STOS
1	-	-	-	SS1S	SLS4S	SLS3S	SLS2S	SLS1S
2	-	-	-	-	-	SBCS	-	-
3	-	-	-	-	-	-	-	-

*1 Values in the empty bits are "0".

- Details of Safety Input

Signal name	Description ^{*1}
STOS	OFF (1): STO function enabled. ON (0): STO function disabled.
SSMS	OFF (0): The motor speed (output frequency) is higher than the SSM frequency. ON (1): The motor speed (output frequency) is equal to or lower than the SSM frequency.
SLS1S	OFF (1): SLS1 function enabled. ON (0): SLS1 function disabled.
SLS2S	OFF (1): SLS2 function enabled. ON (0): SLS2 function disabled.
SLS3S	OFF (1): SLS3 function enabled. ON (0): SLS3 function disabled.
SLS4S	OFF (1): SLS4 function enabled. ON (0): SLS4 function disabled.
SS1S	OFF (1): SS1 function enabled. ON (0): SS1 function disabled.
SBCS ^{*2}	OFF (1): The brake is operating. ON (0): The brake is released.

*1 The value "0" or "1" in the parentheses is the bit value.

*2 The signal is used for monitoring. It is not used for controlling the brake.

*3 Set Attribute service for Attribute 3 Data of Instance 190 is not available.

◆ Safety Supervisor Object (39h)

■ Service

Class	Instance
Get Attribute Single	Get Attribute Single Set Attribute Single

■ Class attribute

No.	Name	Access	Type	Value	Remarks
1	Revision	Get	UINT	0001h	Revision of the object

■ Instance attribute

No.	Name	Access	Type	Value	Remarks
11	Device Status	Get	USINT	-	Inverter status 0: Undefined 1: Self-Testing 2: Idle 3: Self-Test Exception 4: Executing 5: Abort 6: Critical Fault 7: Configuring 8: Waiting for TUNID
12	Exception Status	Get	BYTE	Fixed to 0.	Device diagnosis data
15	Alarm Enable	Set	BOOL	-	
16	Warning Enable	Set	BOOL	-	
25	Configuration UNID	Get	10 octets	All fixed to 0xFF.	The owner of the device setting is identified. 0: Not set. All owners are accepted. 0xFF set for all: Set via software only.
26	Safety Configuration Identifier	Get	10 octets	-	The SCID is read.
27	Target UNID	Get	10 octets	-	The TUNID is read.
28	Output Connection Point Owners	Get	-	-	-
	Number of Array Entries		UINT	01	Number of OCPUNID structure entries
	Output Owners		ARRAY of STRUCT	-	-
	OCPUNID		10 octets	-	UNID of the owner of the output resource. 0: Not owned. The owner is accepted (default).
	ePath Size		USINT	05	Path size, number of bytes.
	Application Resource		Packed ePath	20 04 25 8C 00h	Path to the owner resource.

◆ Safety Validator Object (3Ah)

The instance is generated when Safety I/O connection is established.

■ Service

Class	Instance
Get Attribute Single	Get Attribute Single
Reset all error counters	Set Attribute Single

■ Class attribute

No.	Name	Access	Type	Value	Remarks
1	Revision	Get	UINT	0001h	Revision of the object
8	Safety Connection Fault Count	Get	UINT	-	Number of CIP Safety connection errors

■ Instance attribute

No.	Name	Access	Type	Value	Remarks
1	Safety Validator State	Get	USINT	-	CIP Safety connection status 0: Not connected 1: Initializing 2: Connected 3: Connection failed
2	Safety Validator Type	Get	USINT	-	Present safety connection type • Bit 7 0: Producer (Safety Input) 1: Consumer (Safety Output) • Bit 0 to 6 0: Not connected 1: Single-cast
3	Ping Interval EPI Multiplier	Get	UINT	-	Ping_Count_Interval for connection
4	Time Coord Msg Min Multiplier	Get	STRUCT of:	-	-
	Time Coord Msg Min Multiplier array size		USINT	-	Minimum multiplier array size for the time coordination message
	Time Coord Msg Min Multiplier		Array of UINT	-	Minimum multiplier for the time coordination message
5	Network Time Expectation Multiplier	Get	STRUCT of:	-	-
	Network Time Expectation Multiplier array size		USINT	-	Array size of the network time expectation multiplier
	Network Time Expectation Multiplier		Array of UINT	-	Network time expectation multiplier
6	Timeout Multiplier	Get	STRUCT of:	-	-
	Timeout Multiplier array size		USINT	-	Array size of the timeout multiplier
	Timeout Multiplier		Array of USINT	-	Timeout multiplier
7	Max Consumer Number	Get	USINT	1	Maximum consumer number permitted for the connection
12	Max Data Age	Set	UINT	-	Oldest data age detected (oldness of the data) (128 μ s interval)
13	Application Data Path	Get	EPATH	-	Safety data path for connection
14	Error Code	Get	UINT	-	Error in the Safety Validator instance 0: No error Other than 0: Safety I/O error
15	Producer/Consumer Fault Counters	Get	STRUCT of:	-	-
	Producer/Consumer Counter Array Size		USINT	1	Array size of the producer/consumer counter
	Producer/Consumer Fault Counter		Array of USINT	-	Communication error count in the past one hour

6.3.4 Restrictions and precautions

- The transmission interval of Explicit message during Safety I/O communication must be equal to or more than the RPI of the Safety I/O communication.
- To replace the inverter, clear the setting information of the existing inverter in the safety network configuration beforehand. After replacement, check that the devices are set correctly and operate properly.
- The system common SNN must be used for all devices on the safety network.
- Perform test operation before starting operation of the system to check that the system operates according to the settings.
- LEDs do not satisfy the requirements of safety related applications. They are used only to check the status for test operation and during troubleshooting. Do not use LEDs for safety sub-functions.

7 Protective Functions

◆ Inverter fault and alarm indications

- When a fault of safety related parts occurs, the inverter output is shut off by the protective function. The Fault (ALM) signal is output, and "E.SAF" (safety circuit fault) is displayed on the operation panel.
- When any protective function is activated, take an appropriate corrective action before resetting the inverter. Check that safety sub-functions work properly before resuming the operation. Restarting the operation without a reset may break or damage the inverter.
- When a protective function is activated, note the following points.

Item	Description
Fault signal	Opening the magnetic contactor (MC) provided on the input side of the inverter at a fault occurrence shuts off the control circuit power to the inverter, therefore, the fault output will not be retained.
Fault or alarm indication	When the protective function is activated, the operation panel displays a fault indication.
Operation restart method	While the protective function is activated, the inverter output is kept shutdown. Power reset or inverter reset is required to restart the operation.

◆ Operation of the SA warning and the SAFE and SAFE2 signals

E.SAF indication ^{*3}	Status of safety related parts	STO function operation status by STOC/SS1C signal	Inverter operating status	SA indication ^{*4}	Output signal ^{*5*6*7}	
					SAFE	SAFE2
Not displayed.	Normal	Normal operation	Operation enabled	Not displayed.	OFF	ON ^{*1}
		STO state ^{*2}	Output shutoff (Safe state)	Displayed.	ON ^{*1}	ON ^{*1}
Displayed.	Fault	-	Output shutoff (Safe state)	Not displayed.	OFF	OFF

*1 If any of the faults shown in the following table occurs, the SAFE signal and the SAFE2 signal are turned OFF.

Fault type	Operation panel indication
Option fault	E.OPT
Communication option fault	E.OP1
Internal storage device fault	E.PE6
Parameter storage device fault (control circuit board)	E.PE
Retry count excess	E.RET
Parameter storage device fault (main circuit board)	E.PE2
Safety circuit fault	E.SAF
Overspeed occurrence	E.OS
Speed deviation excess detection	E.OSD
Signal loss detection	E.ECT
Excessive position fault	E.OD
Brake sequence fault	E.MB1 to E.MB7
Acceleration error	E.OA
CPU fault	E.CPU
	E.5 to E.7
Internal circuit fault	E.13

*2 When safety communication functions are enabled (Pr.S002 ≠ "0"), the STO state is activated while the safety communication is not established.

*3 If another fault occurs when the fault E.SAF occurs, the other fault indication may be displayed.

*4 If another warning occurs when the warning SA occurs, the other warning indication may be displayed.

*5 The table shows the signal status in positive logic. In negative logic, the signal status is opposite.

*6 To assign the functions of the SAFE signal and SAFE2 signal to output terminals, set either value shown in the following table. To output the signal via a physical terminal, the function can be assigned to Pr.192 (safety communication model), or Pr.190 to Pr.192, and Pr.197 (IP67 model).

To output the signal via communication, the function can be assigned also to Pr.190 to Pr.197 (Output terminal function selection) using communication protocols. For details, refer to the Instruction Manual (Communication) or the Instruction Manual of the communication option.

Output signal	Pr.190 to Pr.197 settings	
	Positive logic	Negative logic
SAFE	80	180
SAFE2	81	181

*7 The use of the SAFE signal and SAFE2 signal has not been certified for compliance with safety standards.

◆ Reset method for the protective functions

Reset the inverter by performing any of the following operations. Note that the accumulated heat value of the electronic thermal relay function and the number of retries are cleared (erased) by resetting the inverter.

- Press the STOP/RESET key on the operation panel. (This operation is valid only when the protective function for a fault is activated.)
- Switch OFF the power once, then switch it ON again.
- Turn ON the Reset (RES) signal for 0.1 second or more. (If the RES signal is kept ON, "Err" appears (blinks) to indicate that the inverter is in a reset status.)

NOTE

- Before resetting the protective function, check the status of the system and the inverter and ensure that restarting the inverter will not cause any problem.
- OFF status of the start signal must be confirmed before resetting the inverter fault. Resetting an inverter fault with the start signal ON restarts the motor suddenly.
- The reset method can be restricted according to the setting of **Pr.75 Reset selection/PU stop selection**. (For details, refer to the FR-E800 Instruction Manual (Function).)

◆ How to check the fault detail code

- The fault detail code can be checked by reading **Pr.986 Display safety fault code**.
- To read the code using FR Configurator2, refer to the FR Configurator2 Instruction Manual.

◆ List of fault detail codes

No.	Name	Description	Corrective action
1 to 37	System failure	Contact your sales representative.	
38 to 40	Safety parameter fault	A fault is detected in the safety parameter setting.	<ul style="list-style-type: none"> • Set the safety parameter correctly. • Perform safety parameter clear. If the problem still persists after taking the above measure, contact your sales representative.
41	Safety parameter combination fault	<ul style="list-style-type: none"> • A value other than "0" is set in Pr.S023 SBC brake operation frequency and "0 (initial value)" is set in Pr.S001 Monitoring speed selection. • Although the SBC output (SBC) signal is assigned to output terminals, the Brake feedback (SBCFB) signal is not assigned to input terminals. 	<ul style="list-style-type: none"> • When Pr.S023 ≠ "0", set Pr.S001 = "1". • When Pr.S055 SY1/SY2 terminal function selection = "1", set Pr.S051 SX1/SX2 terminal function selection = "6".
44 to 46	System failure	Contact your sales representative.	
47	CPU fault	A CPU fault (E.CPU, E.6, or E.7) occurred.	<ul style="list-style-type: none"> • Refer to the FR-E800 Instruction Manual (Maintenance). If the problem still persists after taking the above measure, contact your sales representative.
49	SX1/SX2 terminal test pulse diagnosis fault	A fault is detected by the test pulse diagnosis.	<ul style="list-style-type: none"> • Set Pr.S061 SX1/SX2 terminal filtering time correctly. If the problem still persists after taking the above measure, contact your sales representative.
54	SX1/SX2 terminal input mismatch fault	The input mismatch between terminals SX1 and SX2 persists for the time period set in Pr.S066 SX1/SX2 terminal mismatch permissible time or longer.	Check the wiring for terminals SX1 and SX2.
58	SY1/SY2 terminal read-back fault	A fault is detected by the output read-back diagnosis.	<ul style="list-style-type: none"> • Check that the power supply of output terminals is normal. • Take measures against noises. If the problem still persists after taking the above measure, contact your sales representative.

No.	Name	Description	Corrective action
61	SY1/SY2 terminal test pulse diagnosis fault	A fault is detected by the test pulse diagnosis.	<ul style="list-style-type: none"> • Take measures against noises. If the problem still persists after taking the above measure, contact your sales representative.
69	Safety communication error	A safety communication error is detected.	<ul style="list-style-type: none"> • Check the wiring. • Take measures against noises. • Set the timeout time correctly.
71	Monitoring speed selection fault	The SLS function or the SSM function was activated while "0 (initial value)" is set in Pr.S001 Monitoring speed selection .	<ul style="list-style-type: none"> • To use the SLS function or the SSM function, set Pr.S001 = "1". • Check if the SLS command or SSM command is input by mistake.
72	SLS1 overspeed	The time set in Pr.S018 SLS speed detection delay time has elapsed after the motor speed exceeded the Pr.S006 SLS frequency 1 .	<ul style="list-style-type: none"> • Check if the start command is turned ON or the Pr.S014 SLS operation frequency 1 setting is equal to or more than the Pr.S006 setting. • Check if the Pr.S010 SLS deceleration monitoring time 1 setting is too short. • In consideration of acceleration/deceleration time, change the setting so that the motor speed becomes equal to or lower than the Pr.S006 setting within the time set in Pr.S010.
73	SLS2 overspeed	The time set in Pr.S018 SLS speed detection delay time has elapsed after the motor speed exceeded the Pr.S007 SLS frequency 2 .	<ul style="list-style-type: none"> • Check if the start command is turned ON or the Pr.S015 SLS operation frequency 2 setting is equal to or more than the Pr.S007 setting. • Check if the Pr.S011 SLS deceleration monitoring time 2 setting is too short. • In consideration of acceleration/deceleration time, change the setting so that the motor speed becomes equal to or lower than the Pr.S007 setting within the time set in Pr.S011.
74	SLS3 overspeed	The time set in Pr.S018 SLS speed detection delay time has elapsed after the motor speed exceeded the Pr.S008 SLS frequency 3 .	<ul style="list-style-type: none"> • Check if the start command is turned ON or the Pr.S016 SLS operation frequency 3 setting is equal to or more than the Pr.S008 setting. • Check if the Pr.S012 SLS deceleration monitoring time 3 setting is too short. • In consideration of acceleration/deceleration time, change the setting so that the motor speed becomes equal to or lower than the Pr.S008 setting within the time set in Pr.S012.
75	SLS4 overspeed	The time set in Pr.S018 SLS speed detection delay time has elapsed after the motor speed exceeded the Pr.S009 SLS frequency 4 .	<ul style="list-style-type: none"> • Check if the start command is turned ON or the Pr.S017 SLS operation frequency 4 setting is equal to or more than the Pr.S009 setting. • Check if the Pr.S013 SLS deceleration monitoring time 4 setting is too short. • In consideration of acceleration/deceleration time, change the setting so that the motor speed becomes equal to or lower than the Pr.S009 setting within the time set in Pr.S013.
76	SBC feedback signal fault	The status of the SBC output (SBC) signal and the Brake feedback (SBCFB) signal is inconsistent with the Pr.S026 SBC FB input selection setting for the time longer than the time set in Pr.S027 SBC mismatch detection time .	<ul style="list-style-type: none"> • Check for brake operation faults. • Check the wiring for terminals SX1 and SX2. • Set Pr.S026 according to the logic of the SBCFB signal.

8 Safety Specifications

The safety specifications are shown in the following table.

Item	Value
	Safety Integrity Level (SIL) 3
PFD _{AVG}	4.5×10^{-4}
PFH _D	7.5×10^{-9}
PL	e
MTTF _D	100 years
DC _{AVG}	60%

MEMO

Warranty

When using this product, make sure to understand the warranty described below.

1. Warranty period and coverage

We will repair any failure or defect (hereinafter referred to as "failure") in our FA equipment (hereinafter referred to as the "Product") arisen during warranty period at no charge due to causes for which we are responsible through the distributor from which you purchased the Product or our service provider. However, we will charge the actual cost of dispatching our engineer for an on-site repair work on request by customer in Japan or overseas countries. We are not responsible for any on-site readjustment and/or trial run that may be required after a defective unit are repaired or replaced.

[Term]

The term of warranty for Product is twelve months after your purchase or delivery of the Product to a place designated by you or eighteen months from the date of manufacture whichever comes first ("Warranty Period"). Warranty period for repaired Product cannot exceed beyond the original warranty period before any repair work.

[Limitations]

- (1) You are requested to conduct an initial failure diagnosis by yourself, as a general rule. It can also be carried out by us or our service company upon your request and the actual cost will be charged.
However, it will not be charged if we are responsible for the cause of the failure.
- (2) This limited warranty applies only when the condition, method, environment, etc. of use are in compliance with the terms and conditions and instructions that are set forth in the instruction manual and user manual for the Product and the caution label affixed to the Product.
- (3) Even during the term of warranty, the repair cost will be charged on you in the following cases;
 - a failure caused by your improper storing or handling, carelessness or negligence, etc., and a failure caused by your hardware or software problem
 - a failure caused by any alteration, etc. to the Product made on your side without our approval
 - a failure which may be regarded as avoidable, if your equipment in which the Product is incorporated is equipped with a safety device required by applicable laws and has any function or structure considered to be indispensable according to a common sense in the industry
 - a failure which may be regarded as avoidable if consumable parts designated in the instruction manual, etc. are duly maintained and replaced
 - any replacement of consumable parts (condenser, cooling fan, etc.)
 - a failure caused by external factors such as inevitable accidents, including without limitation fire and abnormal fluctuation of voltage, and acts of God, including without limitation earthquake, lightning and natural disasters
 - a failure generated by an unforeseeable cause with a scientific technology that was not available at the time of the shipment of the Product from our company
 - any other failures which we are not responsible for or which you acknowledge we are not responsible for

2. Term of warranty after the stop of production

- (1) We may accept the repair at charge for another seven (7) years after the production of the product is discontinued. The announcement of the stop of production for each model can be seen in our Sales and Service, etc.
- (2) Please note that the Product (including its spare parts) cannot be ordered after its stop of production.

3. Service in overseas

Our regional FA Center in overseas countries will accept the repair work of the Product; however, the terms and conditions of the repair work may differ depending on each FA Center. Please ask your local FA center for details.

4. Exclusion of loss in opportunity and secondary loss from warranty liability

Regardless of the gratis warranty term, Mitsubishi Electric shall not be liable for compensation to:

- (1) Damages caused by any cause found not to be the responsibility of Mitsubishi Electric.
- (2) Loss in opportunity, lost profits incurred to the user by Failures of Mitsubishi Electric products.
- (3) Special damages and secondary damages whether foreseeable or not, compensation for accidents, and compensation for damages to products other than Mitsubishi Electric products.
- (4) Replacement by the user, maintenance of on-site equipment, start-up test run and other tasks.

5. Change of Product specifications

Specifications listed in our catalogs, manuals or technical documents may be changed without notice.

6. Application and use of the Product

- (1) For the use of our product, its applications should be those that may not result in a serious damage even if any failure or malfunction occurs in product, and a backup or fail-safe function should operate on an external system to product when any failure or malfunction occurs.
- (2) Our product is designed and manufactured as a general purpose product for use at general industries.
Therefore, applications substantially influential on the public interest for such as atomic power plants and other power plants of electric power companies, and also which require a special quality assurance system, including applications for railway companies and government or public offices are not recommended, and we assume no responsibility for any failure caused by these applications when used.

In addition, applications which may be substantially influential to human lives or properties for such as airlines, medical treatments, railway service, incineration and fuel systems, man-operated material handling equipment, entertainment machines, safety machines, etc. are not recommended, and we assume no responsibility for any failure caused by these applications when used. We will review the acceptability of the abovementioned applications, if you agree not to require a specific quality for a specific application. Please contact us for consultation.

mitsubishi electric corporation

HEAD OFFICE: TOKYO BUILDING 2-7-3, MARUNOUCHI, CHIYODA-KU, TOKYO 100-8310, JAPAN