

mitsubishi

CC-Link System

Spring Clamp Terminal Block Type

Repeater Hub Module

User's Manual

AJ65BTS-RPH

Thank you for buying the Mitsubishi general-purpose programmable controller MELSEC-A series.

Prior to use, please read both this manual and related manuals thoroughly and familiarize yourself with the product.



MODEL	AJ65BTS-RPH-U
MODEL CODE	13JP97
IB(NA)-0800346-C(1112)MEE	

●SAFETY PRECAUTIONS●



(Read these precautions before using.)

When using Mitsubishi equipment, thoroughly read this manual and the associated manuals introduced in this manual. Also pay careful attention to safety and handle the module properly.

The precautions given in this manual are concerned with this product. Refer to the user's manual of the network system to use for a description of the network system safety precautions.

In this manual, the safety precautions are classified into two levels:

"⚠ WARNING" and "⚠ CAUTION".

 WARNING	Indicates that incorrect handling may cause hazardous conditions, resulting in death or severe injury.
 CAUTION	Indicates that incorrect handling may cause hazardous conditions, resulting in minor or moderate injury or property damage.

Under some circumstances, failure to observe the precautions given under "⚠ CAUTION" may lead to serious consequences.

Observe the precautions of both levels because they are important for personal and system safety.

Make sure that the end users read this manual and then keep the manual in a safe place for future reference.

[Design Precautions]

WARNING

- Input/output could be switched on or off when a problem occurs in the repeater module.
So build an external monitoring circuit that will monitor any input/output signals that could cause a serious accident.

CAUTION

- Use the module in an environment that meets the general specifications contained in this manual. Using this module in an environment outside the range of the general specifications could result in electric shock, fire, erroneous operation, and damage to or deterioration of the product.
- Do not install the control wires or communication cables together with the main circuit or power wires.
Keep a distance of 100mm (3.94inch) or more between them.
Not doing so could result in malfunctions due to noise.

[Installation Precautions]

CAUTION

- Do not directly touch the module's conductive parts.
Doing so may cause malfunctions or failure of the module.
- Fix the module securely with a DIN rail or screws, and when using screws, tighten them within the specified torque range.
Undertightening can cause a drop, short circuit or malfunction. Overtightening can cause a drop, short circuit or malfunction due to damage to the screw or module.

[Wiring Precautions]

WARNING

- Before installation or wiring, be sure to shut off all phases of the external power supply used in the system.
If the power is not disconnected at all phases an electric shock or product damage may result.

CAUTION

- Always earth the FG terminal to the protective earth conductor. Otherwise there will be an electric shock or misoperation.
- Perform correct wiring for the module according to the product's rated voltage and terminal arrangement. Connecting to a power supply different from rating or miss-wiring may cause fire and/or product failure.
- Ensure that no foreign matter such as chips and wire-offcuts enter the module. Foreign matter can cause a fire, failure or malfunction.
- Be sure that the communication cable connected to the module is kept in the duct or is fixed with cramps.
Failure to do so may cause a damage to the module or cables due to dangling, shifting or inadvertent handling of cable, or malfunction because of bad cable contacts.
- Do not install the control lines together with the communication cables, or bring them close to each other. Failure to do so may cause malfunctions due to noise.
- When disconnecting the communication and power supply cables from the module, do not hold and pull the cable part.
Disconnect the cables after loosening the screws in the portions connected to the module.
Pulling the cables connected to the module can damage the module and cables or can cause a malfunction due to a cable connection fault.

[Starting and Maintenance Precautions]

CAUTION

- Do not disassemble or modify the modules.
Doing so could cause failure, erroneous operation, injury, or fire.
- Be sure to shut down all the phases of the externally supplied power used in the system before cleaning the module, retightening the module fixing screws, and attaching/removing the module.
Not doing so can cause the module to fail or malfunction.
- Do not install/remove the terminal block more than 50 times after the first use of the product. (IEC 61131-2 compliant)
- Before handling the module, make sure to touch a grounded metal object to discharge the static electricity from the human body.
Failure to do so may cause a failure or malfunctions of the module.

[Disposal Precautions]

CAUTION

- When disposing of this product, treat it as industrial waste.

● CONDITIONS OF USE FOR THE PRODUCT ●

(1) Mitsubishi programmable controller ("the PRODUCT") shall be used in conditions;

- i) where any problem, fault or failure occurring in the PRODUCT, if any, shall not lead to any major or serious accident; and
- ii) where the backup and fail-safe function are systematically or automatically provided outside of the PRODUCT for the case of any problem, fault or failure occurring in the PRODUCT.

(2) The PRODUCT has been designed and manufactured for the purpose of being used in general industries.

MITSUBISHI SHALL HAVE NO RESPONSIBILITY OR LIABILITY (INCLUDING, BUT NOT LIMITED TO ANY AND ALL RESPONSIBILITY OR LIABILITY BASED ON CONTRACT, WARRANTY, TORT, PRODUCT LIABILITY) FOR ANY INJURY OR DEATH TO PERSONS OR LOSS OR DAMAGE TO PROPERTY CAUSED BY the PRODUCT THAT ARE OPERATED OR USED IN APPLICATION NOT INTENDED OR EXCLUDED BY INSTRUCTIONS, PRECAUTIONS, OR WARNING CONTAINED IN MITSUBISHI'S USER, INSTRUCTION AND/OR SAFETY MANUALS, TECHNICAL BULLETINS AND GUIDELINES FOR the PRODUCT.

("Prohibited Application")

Prohibited Applications include, but not limited to, the use of the PRODUCT in;

- Nuclear Power Plants and any other power plants operated by Power companies, and/or any other cases in which the public could be affected if any problem or fault occurs in the PRODUCT.
- Railway companies or Public service purposes, and/or any other cases in which establishment of a special quality assurance system is required by the Purchaser or End User.
- Aircraft or Aerospace, Medical applications, Train equipment, transport equipment such as Elevator and Escalator, Incineration and Fuel devices, Vehicles, Manned transportation, Equipment for Recreation and Amusement, and Safety devices, handling of Nuclear or Hazardous Materials or Chemicals, Mining and Drilling, and/or other applications where there is a significant risk of injury to the public or property.

Notwithstanding the above, restrictions Mitsubishi may in its sole discretion, authorize use of the PRODUCT in one or more of the Prohibited Applications, provided that the usage of the PRODUCT is limited only for the specific applications agreed to by Mitsubishi and provided further that no special quality assurance or fail-safe, redundant or other safety features which exceed the general specifications of the PRODUCTS are required. For details, please contact the Mitsubishi representative in your region.

REVISIONS

* The manual number is given on the bottom right of the cover.

Print Date	*Manual Number	Revision
Oct., 2006	IB(NA)-0800346-A	First edition
Dec., 2006	IB(NA)-0800346-B	Correction SAFETY PRECAUTIONS, About the Manual, Section 2.2, 2.3, 3.1, 3.2, 4.2.1
Dec., 2011	IB(NA)-0800346-C	Correction SAFETY PRECAUTIONS, ABOUT MANUALS, COMPLIANCE WITH THE EMC AND LOW VOLTAGE DIRECTIVES, Chapter 1, Section 2.3, 3.1, 3.4, 4.1, 4.2.1, Chapter 6

This manual confers no industrial property rights or any rights of any other kind, nor does it confer any patent licenses. Mitsubishi Electric Corporation cannot be held responsible for any problems involving industrial property rights which may occur as a result of using the contents noted in this manual.

© 2006 MITSUBISHI ELECTRIC CORPORATION

CONTENTS

1. OVERVIEW	1
1.1 Features	1
2. SYSTEM CONFIGURATION	3
2.1 Total configuration	3
2.2 Applicable system	4
2.3 Cautions on system configuration	5
3. SPECIFICATION	12
3.1 General specifications	12
3.2 Performance specifications	14
3.3 Specifications of connection cable	17
3.4 Maximum transmission distance	18
4. PROCEDURE UP TO START OF DATA LINK	19
4.1 Procedure up to start of data link	19
4.2 Mounting and installation	20
4.2.1 Cautions on handling	20
4.2.2 Installation environment	23
4.3 Names and settings of parts	24
4.4 Connection of module through CC-Link dedicated cable	28
4.5 Check for state of connection (line test)	29
5. TROUBLESHOOTING	32
6. EXTERNAL DIMENSIONS	36

ABOUT MANUALS

The following manuals are also related to this product.
In necessary, order them by quoting the details in the tables below.

Related Manuals

Manual name	Manual No. (Model code)
CC-Link System Master/Local Module Type AJ61BT11/ A1SJ61BT11 User's Manual	IB-66721 (13J872)
CC-Link System Master/Local Module Type AJ61QBT11/ A1SJ61QBT11 User's Manual	IB-66722 (13J873)
CC-Link System Master/Local Module User's Manual	SH-080394E (13JR64)
CC-Link System Repeater (T-junction) Module User's Manual AJ65SBT-RPT	IB-0800078 (13JQ81)
CC-Link System Optical Repeater Module User's Manual AJ65SBT-RPS/AJ65SBT-RPG	IB-0800089 (13JQ85)
CC-Link System Space Optical Repeater Module User's Manual AJ65BT-RPI-10A/AJ65BT-RPI-10B	IB-0800090 (13JQ86)
CC-Link System Low Profile Waterproof Type Repeater Hub Module User's Manual	IB-0800288 (13JP55)

COMPLIANCE WITH EMC AND LOW VOLTAGE DIRECTIVES

(1) Method of ensuring compliance

To ensure that Mitsubishi programmable controllers maintain EMC and Low Voltage Directives when incorporated into other machinery or equipment, certain measures may be necessary. Please refer to one of the following manuals.

- User's manual for the CPU module or head module used
- Safety Guidelines

(this manual is included with the CPU module, base unit, or head module)

The CE mark on the side of the programmable controller indicates compliance with EMC and Low Voltage Directives.

(2) Additional measures

To ensure that this product maintains EMC and Low Voltage Directives, please refer to one of the manuals listed under (1).

Abbreviated names, generic names and terms

Abbreviated names, generic names and terms	Description
AJ-65BTS-RPH	Abbreviation of AJ65BTS-RPH type CC-Link system spring clamp terminal Block type Repeater hub module.
AJ65FBTA-RPH	Abbreviation of AJ65FBTA-RPH type CC-Link system low profile waterproof type repeater hub module.
AJ65SBT-RPT	Abbreviation of AJ65SBT-RPT type CC-Link system repeater (T-junction) module.
AJ65SBT-RPS/RPG	Abbreviation of AJ65SBT-RPS/AJ65SBT-RPG type CC-Link system optical repeater module.
AJ65BT-RPI-10A/10B	Abbreviation of AJ65BT-RPI-10A/AJ65BT-RPI-10B type CC-Link system space optical repeater module.
AJ65SBT-CLB	Abbreviation of AJ65SBT-CLB CC-Link - CC-Link/LT bridge module.
Segment	System between terminating resistors connected to each other through cross-over cables. The conventional CC-Link system can be said to be configured with one segment.
Master station	Station to control the data link system. One station is required for each system.
Local station	Station which has a sequencer CPU and can communicate with the master station and the other local stations.
Remote I/O station	Remote station processing only information in unit of bit. (AJ65BTB1-16D, AJ65SBTB1-16D, etc.)
Remote device station	Remote station processing only information in unit of bit and in unit of word. (AJ65BT-64AD, AJ65BT-64DAV, AJ65BT-64DAI, etc.)
Remote station	Generic name of remote I/O station and remote device station. Controlled by the master station.
Intelligent device station	Station allowing transient transmission such as AJ65BT-R2. (Including local stations)
Repeater	Module for expanding the CC-Link system by connecting the segments to each other.
Standby master station	Backup station which inherits data link control when the master station comes off parallel due to error.
Slave station	Generic term of remote I/O station, remote device station, local station, intelligent device station, and standby master station.
Master local module	Generic name of QJ61BT11N, QJ61BT11, AJ61BT11, A1SJ61BT11, AJ61QBT11 and A1SJ61QBT11.
Master module	Generic term for modules that can be used as the master station.
Local module	Generic term for modules that can be used as the local station.

Abbreviated names, generic names and terms	Description
Intelligent device module	Module allowing transient transmission such as AJ65BT-R2.

Product structure

The product structure of AJ65BTS-RPH is as shown below.

Product name	Quantity
AJ65FBTA-RPH module	1
Terminating resistor kit	1
For a trunk line (Bar terminal type): 110Ω (brown, brown, brown)	1
For a trunk line (Bar terminal type): 130Ω (brown, orange, brown)	1
For a branch line (Y terminal type): 110Ω (brown, brown, brown)	8

1. OVERVIEW

This user's manual describes the specifications, names of parts, and settings of the AJ65BTS-RPH CC-Link system spring clamp terminal block type repeater hub module (hereafter abbreviated as AJ65BTS-RPH) used in the CC-Link system.

1.1 Features

The AJ65BTS-RPH is the module designed for improving flexibility in cable wiring of the CC-Link system.

Using the AJ65BTS-RPH allows the extension of the transmission distance and star-topology wiring (with 8 branch lines) in the CC-Link system.

- (1) Star-topology wiring (T-branch) with 8 branch lines (segments) available in CC-Link system

By placing the AJ65BTS-RPH between modules of the CC-Link system, star-topology wiring (T-branch) with up to 8 branch lines (segments) can be used in the CC-Link system of all transmission rates (10Mbps, 5Mbps, 2.5Mbps, 625kbps, and 156kbps).

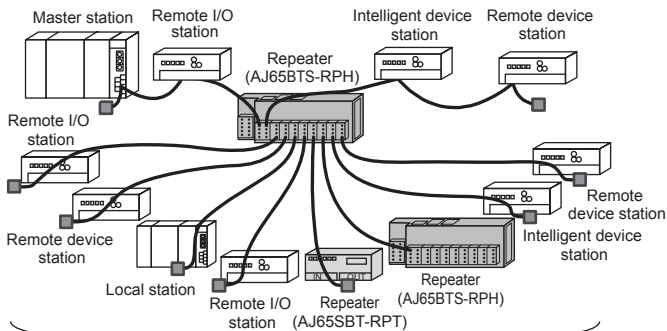

(2) Extended transmission distance in CC-Link system

Use of AJ65BTS-RPH enables the transmission distance of the CC-Link system to be extended.

In addition, use of multiple modules enables the transmission distance of the CC-Link system to be extended up to 2 stages.

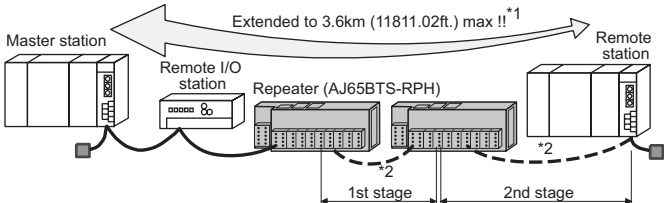

*1 Max. transmission distance at a transmission speed of 156kbps.

*2 Though it is not shown here, the other remote stations can be connected between the repeaters.

(3) Energy saving realized by adoption of a spring clamp terminal block

(a) The AJ65BTS-RPH has adopted a spring clamp terminal block. Because screw tightening is not needed, working steps can be reduced.

(b) The terminal block can be installed to or removed from the module, which reduces the maintenance cost and improves the maintainability.

(c) All the operation and wiring parts are placed on the module front, allowing easier operation and wiring.

(4) Improved maintainability by system separation

By using the AJ65BTS-RPH, any of the systems can be separated and error location can be identified quickly.

This prevents the whole system from being seriously affected by an error.

POINT

Branch lines with no error can send/receive data normally, not influenced by each other.
--

2. SYSTEM CONFIGURATION

2.1 Total configuration

The total configuration employed when the AJ65BTS-RPH is used is as shown below.

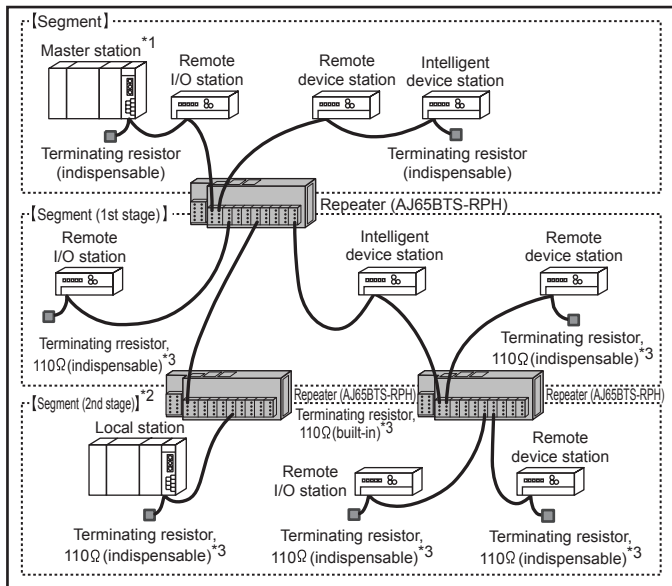

*1 The transmission speed of each segment must be matched with that of the master station.

*2 2 stages of segments max. are allowed to be used.

*3 The 130Ω terminating resistor is not usable for a segment connected on the branch line side of the AJ65BTS-RPH.

Use the 110Ω terminating resistor that is included with the AJ65BTS-RPH.

2.2 Applicable system

This section describes usable modules and cables.

(1) Modules connectable on the branch line side

The types of the modules connectable on the branch line side of the AJ65BTS-RPH are shown below.

Table 2.1 Modules connectable on the branch line side

Category	Module types
Slave station	Remote I/O station
	Remote device station
	Intelligent device station
	Local station
Repeater	AJ65BTS-RPH
	AJ65FBTA-RPH
	AJ65SBT-RPT
	AJ65SBT-RPS/RPG
	AJ65BT-RPI-10A/10B
Bridge	AJ65SBT-CLB

(2) Applicable communication cables

The communication cables connectable to the AJ65BTS-RPH are shown below.

Table 2.2 Applicable communication cables

Connector name	Applicable cable		Terminal resistance
	CC-Link version	Name	
Trunk line side	Ver.1.00	CC-Link dedicated high-performance cable	130Ω
		CC-Link dedicated cable	110Ω
Ver.1.10	CC-Link dedicated cable		
Branch line side	Ver.1.00	CC-Link dedicated cable	
	Ver.1.10	CC-Link dedicated cable	

POINT

The master station and stand by master station can not be connected to the branch line side.

2.3 Cautions on system configuration

(1) Conditions of usable master module

When the AJ61BT11, A1SJ61BT11, AJ61QBT11 and A1SJ61QBT11 modules are used, those of the functional version B or later must be employed. Use the master module bearing the version 9707 B or later in the DATE column of the name plate as shown in the figure below.

When the QJ61BT11N, QJ61BT11 module are used, any module can be used irrespective of the version.

(a) Rating plate of AJ61BT11 or AJ61QBT11

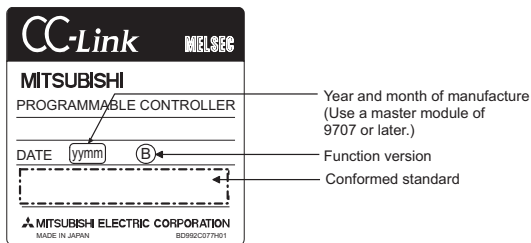

(b) Rating plate of A1SJ61BT11 or A1SJ61QBT11

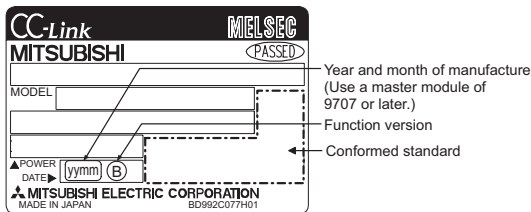

- (2) Max. number of modules connected to configure CC-Link system
 Up to 64 modules of repeaters can be connected in one segment.
 In the CC-Link system where repeaters are used, also the number of remote stations capable of being controlled by one master station is the same as in the other systems.
 For details, refer to the User's Manual of the applicable master module.
- (3) Max. number of stages connected to configure segment
 Use of AJ65BTS-RPH enables communication between the master station located in a segment and a remote station located in a segment apart by 2 stages max. from the segment where the master station exists.

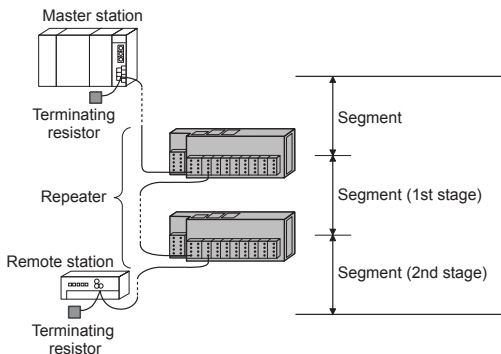

- (4) Instructions for using different models of repeaters in combination
 Note that when combining the repeaters of different models, there are the following restrictions on the number of connectable repeaters and the number of connected stages.

Table 2.3 Max. number of repeaters when using different models

Combination pattern	Max. number of repeaters						Max. number of stages
	AJ65BTS -RPH	AJ65FBTA -RPH	AJ65SBT -RPT	AJ65SBT -RPS	AJ65SBT -RPG	AJ65BT -RPI -10A/10B	
1)	1	—	2	—	—	—	3
	—	1	2	—	—	—	
2)	1	—	—	2(1set)	-	—	2
	1	—	—	—	2(1set)	—	
	—	1	—	2(1set)	—	—	
	—	1	—	—	2(1set)	—	
3)	1	—	—	—	—	2(1set)	2
	—	1	—	—	—	2(1set)	
4)	—	—	2	4(2set)	—	—	4
5)	—	—	2	—	2(1set)	—	3
6)	—	—	2	—	—	2(1set)	
7)	—	—	—	2(1set)	2(1set)	—	2
8)	—	—	—	2(1set)	—	2(1set)	
	—	—	—	—	2(1set)	2(1set)	
9)	1	1	—	—	—	—	

POINT

- For the CC-Link system, up to 2 repeater types can be used in combination.
Using 3 models or more is not allowed.
- When repeaters are connected in the same segment by link wiring, up to 64 modules can be connected.
For details, refer to the user's manual of the master module used.
- Ex.) A CC-Link system with combination pattern 3) is built

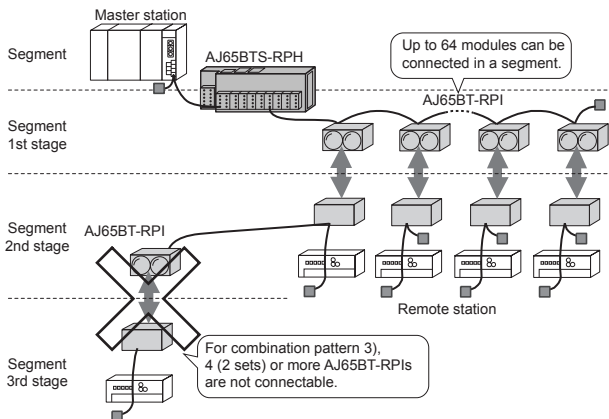

(a) Combination pattern 1)

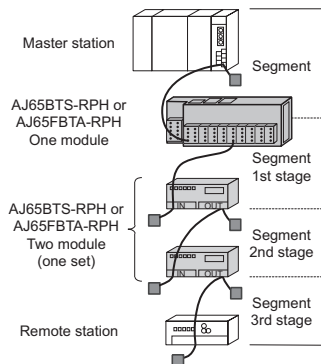

(b) Combination pattern 2)

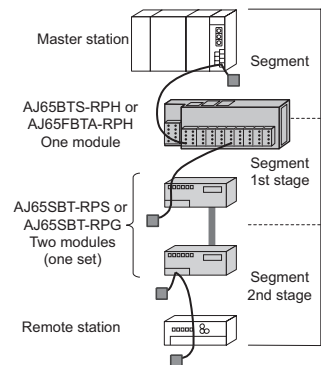

(c) Combination pattern 3)

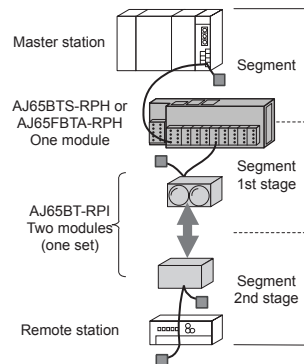

(d) Combination pattern 4)

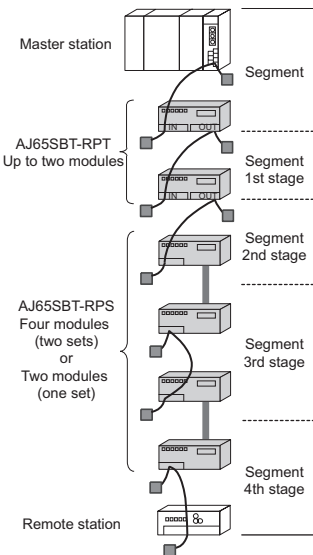

(e) Combination pattern 5)

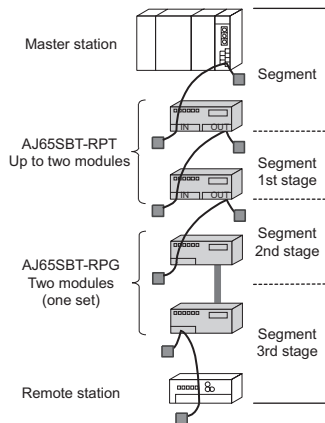

(g) Combination pattern 7)

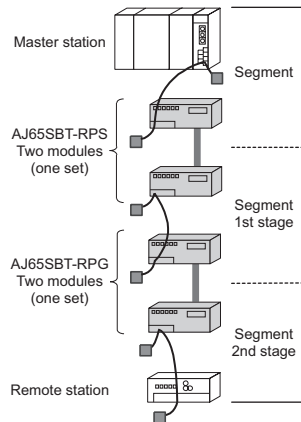

(f) Combination pattern 6)

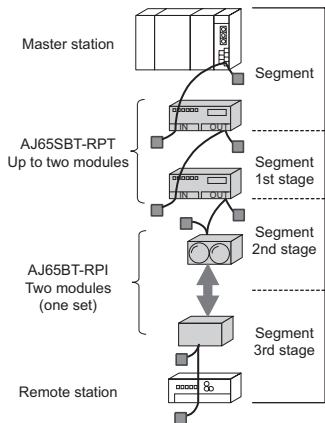

(h) Combination pattern 8)

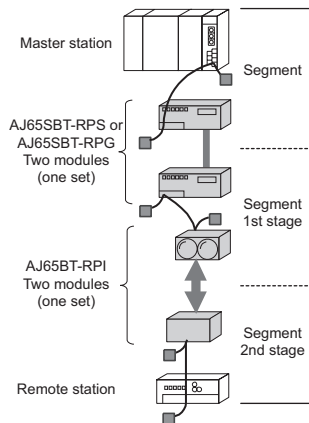

(i) Combination pattern 9)

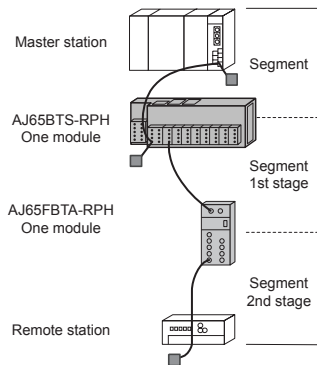

3. SPECIFICATION

3.1 General specifications

The General specifications of the AJ65BTS-RPH are shown below.

Table 3.1 General specifications

Item	Specifications					
Operating ambient temperature	0 to 55°C					
Storage ambient temperature	-20 to 75°C					
Operating ambient humidity	10 to 90%RH, non-condensing					
Storage ambient humidity						
Vibration resistance	Compliant with JIS B 3502 and IEC 61131-2	Under intermittent vibration	Frequency	Constant acceleration	Half amplitude	Sweep count
			5 to 8.4Hz	—	3.5mm	10 times each in X, Y, Z directions
		Under continuous vibration	8.4 to 150Hz	9.8m/s ²	—	
			5 to 8.4Hz	—	1.75mm	—
8.4 to 150Hz	4.9m/s ²	—				
Shock resistance	Compliant with JIS B 3502 and IEC 61131-2 (147m/s ² , 3 times each in 3 directions X, Y, Z)					
Operating atmosphere	No corrosive gases					
Operating altitude ^{*3}	0 to 2000m					
Installation location	Inside a control panel ^{*4}					
Overvoltage category ^{*1}	II or less					
Pollution degree ^{*2}	2 or less					

- *1 This indicates the section of the power supply to which the equipment is assumed to be connected between the public electrical power distribution network and the machinery within premises.
Category II applies to equipment for which electrical power is supplied from fixed facilities. The surge voltage withstand level for up to the rated voltage of 300V is 2500V.
- *2 This index indicates the degree to which conductive material is generated in terms of the environment in which the equipment is used. Pollution level 2 is when only non-conductive pollution occurs. A temporary conductivity caused by condensing must be expected occasionally.
- *3 Do not use or store the programmable controller under pressure higher than the atmospheric pressure of altitude 0m. Doing so may cause malfunction. When using the programmable controller under pressure, please consult your local Mitsubishi Electric representative.
- *4 It can also be installed to any other than a control panel if the conditions such as operating ambient temperature and humidity are satisfied.

3.2 Performance specifications

The performance specifications of the AJ65BTS-RPH module are shown below.

Table 3.2 Performance specifications (1/2)

Item	Specifications	
Station number	— (none)	
CC-Link station type	— (none)	
Number of occupied stations	0 (none)	
Transmission rate	Can select from 156kbps / 625kbps / 2.5Mbps / 5Mbps / 10Mbps	
No. of connectable slave stations	The total number of modules connected to a trunk line and branch line shall conform to the maximum number of connectable modules of the master module used. For details, refer to the user's manual of the master modules used.	
Max. No. of modules connected to the trunk line	64 (Refer to Section 2.3(2))	
Connection position	Trunk line side	No restriction (compliant with the CC-Link specifications)
	Branch line side	Connect to the end of the branch line (segment end)
Max. number of stages connected to configure segment	AJ65BTS-RPH only (Refer to Section 2.3(3))	2nd stage
	Combination of AJ65BTS-RPH and AJ65SBT-RPT (Refer to Section 2.3 (4))	3rd stage
	Combination of AJ65BTS-RPH and one of AJ65FBTA-RPH, AJ65SBT-RPS/RPG, or AJ65BT-RPI (Refer to Section 2.3 (4))	2nd stage
Max. transmission distance of each segment	Varies according to transmission rate (Refer to Section 3.4.).	
Terminating resistor	Trunk line side	110Ω, or 130Ω can be selected.
	Branch line side	110Ω (built-in)
Terminal block	Spring clamp terminal block	
Applicable cable size	AWG #24 to 12, φ0.5 to 1.78mm single cable, 0.2 to 2.5mm ² stranded cable	
Applicable solderless terminal	Refer to table 3.3	

Table 3.2 Performance specifications (2/2)

Item		Specifications
Mounting orientation		No restriction (mountable in six orientations)
Module installation screw		M4 mounting screw
Power supply	Voltage	24V DC external power supply (20.4 to 26.4V, ripple within $\pm 5\%$)
	Current	0.36A (TYP. 24V DC)
Noise durability		Simulator noise of 500 Vp-p, obtained by a noise simulator using noise width of 1 μ s and noise frequency of 25 to 60 Hz
Maximum voltage		500V AC for 1 minute between all DC external terminals and ground
Insulation resistance		10M Ω or higher, measured with a 500V DC insulation resistance tester
Protection of degree		IP2X
External dimensions		197.4mm (7.77in.) (W) \times 65mm (2.56in.) (H) \times 65.8mm (2.59in.) (D)
Weight		0.37kg

Table 3.3 Applicable solderless terminals (bar terminals) and crimp tools

Product name	Model name	Maker	Remark
Bar-type solderless terminal	FA-TVC125T9	Mitsubishi Electric Engineering Co., Ltd.	For CC-Link dedicated cables (0.3 to 1.65mm ²)
Tool for bar-type solderless terminals	FA-NH65A		
Bar-type solderless terminal	TE0.5-10	NICHIFU TERMINAL MFG. Co., Ltd.	For CC-Link dedicated cables (0.3 to 0.5mm ²)
	TE0.75-10		For power supply cables (0.75mm ²)
	TE1.0-10		For power supply cables (1.0mm ²)
	TE1.5-10		For power supply cables (1.5mm ²)
	TE2.5-12		For power supply cables (2.5mm ²)* ²
Tool for bar-type solderless terminals	NH-79		
Bar-type solderless terminal	AI0.5-10WH	PHOENIX CONTACT	For CC-Link dedicated cables (0.5mm ²)
	AI0.75-10GY		For power supply cables (0.75mm ²)
	AI1-10RD		For power supply cables (1.0mm ²)
	AI1.5-10BK		For power supply cables (1.5mm ²)
	AI2.5-10BU		For power supply cables (2.5mm ²)* ²
Tool for bar-type solderless terminals	CRIMPFOX UD6		
	CRIMPFOX UD6-4		*1
	CRIMPFOX UD6-6		*1
	CRIMPFOX ZA3		

*1: When shielding wires, power supply cables of 2 mm² (AWG #14) or FG wires are crimped to bar terminals using the CRIMPFOX UD6-4 or CRIMPFOX UD6-6, bar terminals may not be able to connect to the terminal block depending on the cross-sectional shape after crimping.

*2: When power supply cables of 2 mm² (maximum size of applicable cables) or FG wires are crimped to bar terminals of 2.5 mm², bar terminals may not be able to connect to the terminal block.

3.3 Specifications of connection cable

Use the CC-Link dedicated cable for the CC-Link system. If a cable other than the CC-Link dedicated cable is used, the performance of the CC-Link system cannot be guaranteed.

For the CC-Link cable specifications and any other inquiries, refer to the following:

CC-Link Partner Association website: <http://www.cc-link.org/>

REMARK

For details, refer to the CC-Link cable wiring manual issued by the CC-Link Partner Association.

3.4 Maximum transmission distance

The maximum transmission distance varies depending on the set-up of transmission rate and the number of connected segments (stages).

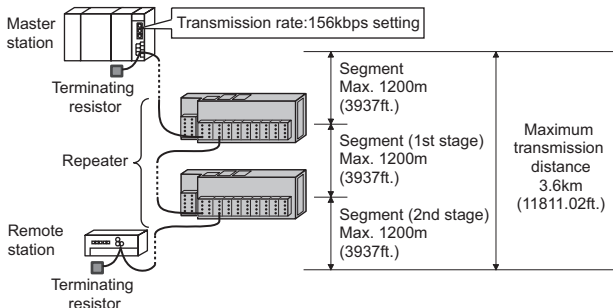

Table 3.4 Conditions for change in maximum transmission distance

Condition	Description
Transmission rate	Maximum transmission distance in each segment is the same as that of the normal CC-Link system (the system with one segment only). It varies depending on the transmission rate. For details, refer to the user's manual of the master module used. (The station-to-station cable length for the repeater is the same as that for the remote I/O station.)
No. of stages for segment connection	Maximum transmission distance for one segment is added for each additional stage connection.

4. PROCEDURE UP TO START OF DATA LINK

4.1 Procedure up to start of data link

The procedure ranging from the installation of the AJ65BTS-RPH module to the start of data link is described below.

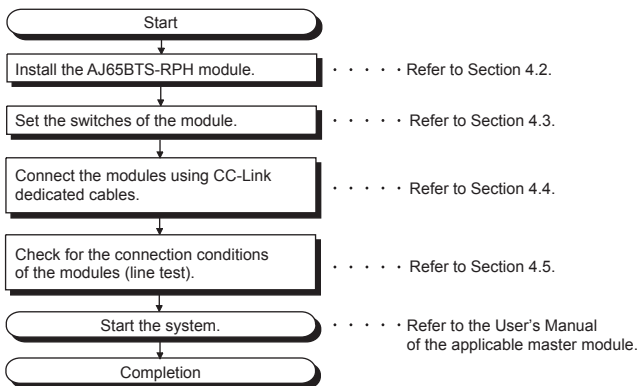

POINT

The procedure described here is for the AJ65BTS-RPH module only. In order for you to understand the procedure of the entire CC-Link system, refer to the User's Manual of the applicable master module.

4.2 Mounting and installation

4.2.1 Cautions on handling

Cautions on handling the AJ65BTS-RPH module are described below.

- (1) Tighten screws (such as a module fixing screw) within the tightening torque range specified in the table below.
Do not over-tighten these screws. The screws and module case may be damaged.

Table 4.1 Specified torque range for each screw

Screw location	Specified torque range
Module installation screw (M4 screws)	0.78 to 1.08N·m
Terminal block fixing screw	0.4 to 0.5N·m (conforming to IEC 60999)

- (2) When a DIN rail is used, install it taking care with the following.
 - (a) Applicable DIN rail type (conforming to IEC 60715)
TH35-7.5Fe
TH35-7.5Al
 - (b) Intervals of DIN rail mounting screws
Mount the DIN rail by fixing it with mounting screws at intervals of 200 mm (7.87inch) or shorter.
- (3) To mount the AJ65BTS-RPH to the DIN rail, hitch the upper hook of the module to the DIN rail securely and push the module into the DIN rail.
(Push the module until the lower hook of the module clicks.)

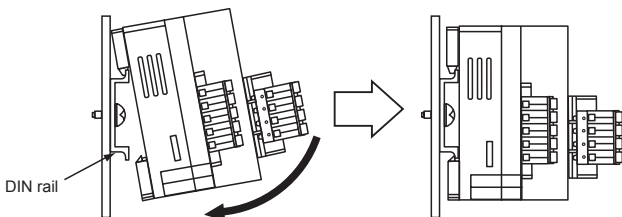

- (4) When installing the AJ65BTS-RPH module on the control panel, to improve the ventilation and facilitate the replacement of the module, provide a distance of 60 mm (2.36inch) or longer between the upper and lower surfaces of the module and the structural members or parts.

- (5) Install the AJ65BTS-RPH module on a flat smooth surface.
If there are irregularities on the installation surface, undue force may be applied to the printed circuit boards, and the boards may be damaged.
- (6) Depending on the grounding condition of the system, a high-frequency noise may occur between the systems. When these systems are connected through CC-Link communication cables, a communication error may occur by the mixing of noise into the repeaters.
If the high-frequency noise occurs between the systems connected through the cables of 10 m (32.79ft.) or shorter, take either of the measures specified below.

Method1: Connect the systems through cables of 2 mm² or larger (across FG terminals of the remote station in each system, or across grounds of the control panel to which the remote station is grounded).

Method2: Use CC-Link cables of 10 m (32.79ft.) or longer between the systems.

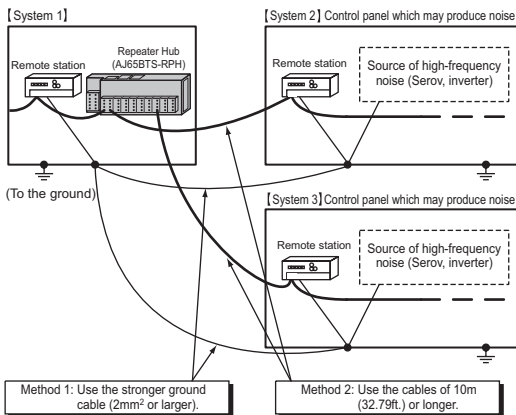

(7) Stripping the cable end

- (a) The cable strip length must be approx. 10mm. If the cable is stripped too much, conductors may stick out of the terminal block and may cause an electric shock or short circuit with an adjacent terminal block.

If the stripped length is too short, sufficient contact may not be ensured.

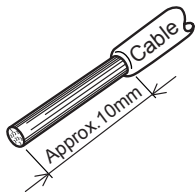

- (b) For use of bar terminals, pay attention to the following:

- 1) Select a bar terminal suitable for the cable size.
- 2) Use an appropriate crimp tool to crimp the bar terminal.
- 3) Insert the cable so that cable cores will stick out 0 to 0.5mm from the sleeve edge.

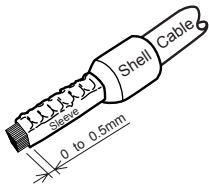

- 4) Check the appearance of the bar terminal after crimping. If it is not crimped properly or is damaged on the side, do not use the terminal. (See the following illustrations.)

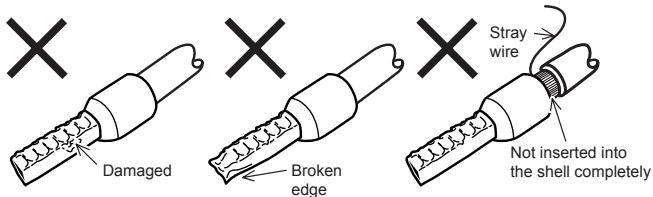

(8) Connecting the cable to the spring clamp terminal block

(a) Connecting the cable

While pressing the open/close button with a flat-head screwdriver, insert the cable into the insertion hole.

- 1) For use of bar terminals, the cable can be inserted without pressing the open/close button.

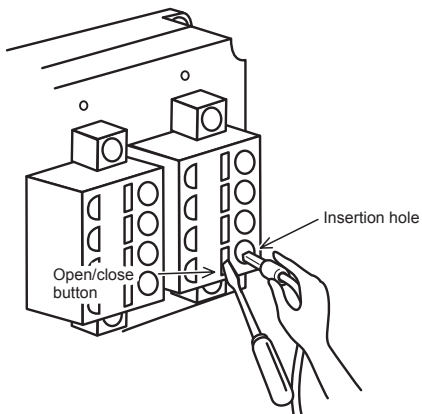

(b) Disconnecting the cable

While fully pressing the open/close button with the flat-head screwdriver, pull out the cable.

4.2.2 Installation environment

For installation environment, refer to Section 3.1.

4.3 Names and settings of parts

The names of parts of the AJ65BTS-RPH module, indication statuses of LEDs, and settings of switches are described below.

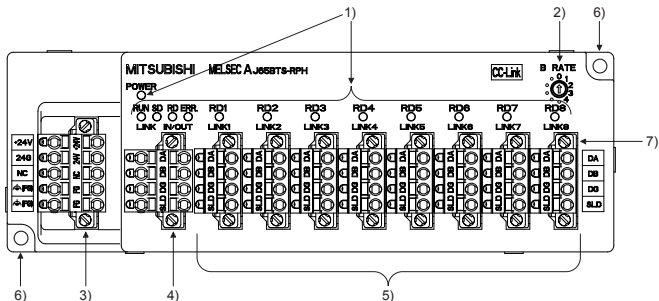

Table 4.2 Names and settings of parts (1/3)

No.	Name	Application		
1)	Operation status display LED	Check for the module condition by observing the state of lighting of the LED.		
		LED Name	Application	
		POWER	ON : Power supply on OFF : Power supply off	
		RUN	ON : Module is operating normally OFF : Module is not operating normally	
		SD LINK IN/OUT	ON : Data are being sent to the LINK IN or LINK OUT of the trunk line OFF : Data are not being sent to the LINK IN or LINK OUT of the trunk line	
		RD LINK IN/OUT	ON : Data are being received from the LINK IN or LINK OUT of the trunk line OFF : Data are not being received from the LINK IN or LINK OUT of the trunk line	
		ERR.	ON : Transmission rate setting out-of-range error or communication error occurred Flickering : Terminating resistor is missing. The module and CC-Link cables are affected by noise. Or the transmission rate was changed after power up. OFF : Module is operating normally	
		RD LINK 1 to 8	ON : Data are being received from the LINK1 to 8 of the branch line. OFF : Data are not being received from the LINK1 to 8 of the branch line.	

Table 4.2 Names and settings of parts (2/3)



No.	Name	Application										
2)	Transmission rate setting switch	Set the transmission rate of the module (set to 0 at the time of delivery). Ensure to set the transmission rate at a speed specified below. Transmission rate of the trunk line side is identical with that of the branch line side.										
		Setting value	Transmission rate (bps)									
		0	156k									
		1	625k									
		2	2.5M									
		3	5M									
		4	10M									
Other than 0 to 4	Cannot be set. If set to other than 0 to 4, the ERR. LED is turned on and data are not transferred.											
3)	Power terminal block	<p>Connects the module power supply (24V DC) and the ground cable (FG: Functional Ground). Terminals are assigned as follows:</p>  <table border="1" data-bbox="523 725 637 848"> <tr> <td>+24V</td> <td>+24V</td> </tr> <tr> <td>24G</td> <td>24G</td> </tr> <tr> <td>NC</td> <td>NC</td> </tr> <tr> <td>FG</td> <td>FG</td> </tr> <tr> <td>FG</td> <td>FG</td> </tr> </table>	+24V	+24V	24G	24G	NC	NC	FG	FG	FG	FG
+24V	+24V											
24G	24G											
NC	NC											
FG	FG											
FG	FG											
4)	Communication terminal block (Trunk line side)	<p>Connects the transmission lines on the trunk line side (LINK IN/OUT). Terminals are assigned as follows:</p>  <table border="1" data-bbox="523 965 637 1064"> <tr> <td>DA</td> <td>DA</td> </tr> <tr> <td>DB</td> <td>DB</td> </tr> <tr> <td>DG</td> <td>DG</td> </tr> <tr> <td>SLD</td> <td>SLD</td> </tr> </table>	DA	DA	DB	DB	DG	DG	SLD	SLD		
DA	DA											
DB	DB											
DG	DG											
SLD	SLD											

Table 4.2 Names and settings of parts (3/3)

No.	Name	Application
5)	Communication terminal block (Branch line side)	Connects the transmission lines on the branch line side (LINK 1 to 8). Terminals are assigned as follows: 
6)	Module fixing hole	Screw hole for fixing the module.
7)	Terminal block fixing screw	Screw for fixing the terminal block.

POINT

Set the same transmission rate as that of the master station.

4.4 Connection of module through CC-Link dedicated cable

The method of connecting the AJ65BTS-RPH module to the CC-Link system through the CC-Link dedicated cable is shown below.

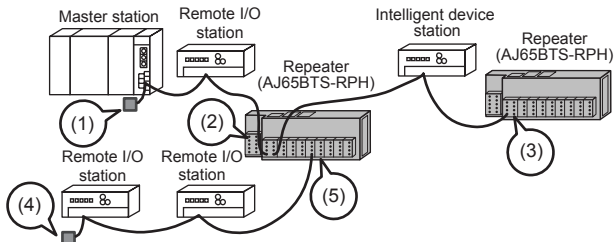

For (1) to (5) shown in the above, read the following cautions on connections.

- (1) For the segment connected to the trunk line side of the AJ65BTS-RPH, connect a terminating resistor to the module connected at the end.
Select a type for terminating resistor in accordance with the type of the connected communication cable.
For details, refer to the manual of the module connected.
- (2) Do not connect any terminating resistor to the AJ65BTS-RPH when the trunk line side is connected to a station that is not located at the end of the segment.
In addition, connect the shielding wire of the CC-Link dedicated cable to "SLD" of each module, and ground both ends via "FG" The interval between SLD and FG is connected in the module in advance.
- (3) Connect the included terminating resistor to the AJ65BTS-RPH when the trunk line side is connected to a station that is located at the end of the segment.
Select a type for terminating resistor in accordance with the type of the connected communication cable.
For details, refer to Section 2.2.
In addition, connect the shielding wire of the CC-Link dedicated cable to "SLD" of each module, and ground both ends via "FG" The interval between SLD and FG is connected in the module in advance.

- (4) Connect the included 110Ω terminating resistor to the module located at the end of a segment when the branch line side of the AJ65BTS-RPH is connected to the segment.
For the connection of terminal resistor, refer to the manual of the module connected.
- (5) For the branch line side of the AJ65BTS-RPH, use the incorporated 110Ω terminating resistor.
In addition, connect the shielding wire of the CC-Link dedicated cable to "SLD" of each module, and ground both ends via "FG".
Note that SLD and FG are connected to each other in the module.

4.5 Check for state of connection (line test)

Connect all modules including the AJ65BTS-RPH module through the CC-Link dedicated cable. Then, check that the CC-Link system is in the state capable of performing a data link normally.

Because whether or not a master station can establish a data link with a particular slave station can be checked by the connection status check (circuit test), an error module can be identified.

For the connection status check (circuit test), perform the circuit test 1 of the master module. If an error is detected, perform the circuit test 2 of the master module.

For the details of circuit tests 1 and 2, refer to the user's manual of the master module used.

Perform the test following the steps shown below.

POINT	
	Perform the circuit test 2 of the master module by selecting the target stations as described in (1) to (3) below.
	(1) In the segment including the master module, select slave stations in order from the nearest to the master module to the farthest.
	(2) In the segment (1st stage), select slave stations in order from the nearest to the AJ65BTS-RPH to the farthest.
	(3) In the segment (2nd stage), select slave stations in order from the nearest to the AJ65BTS-RPH to the farthest.

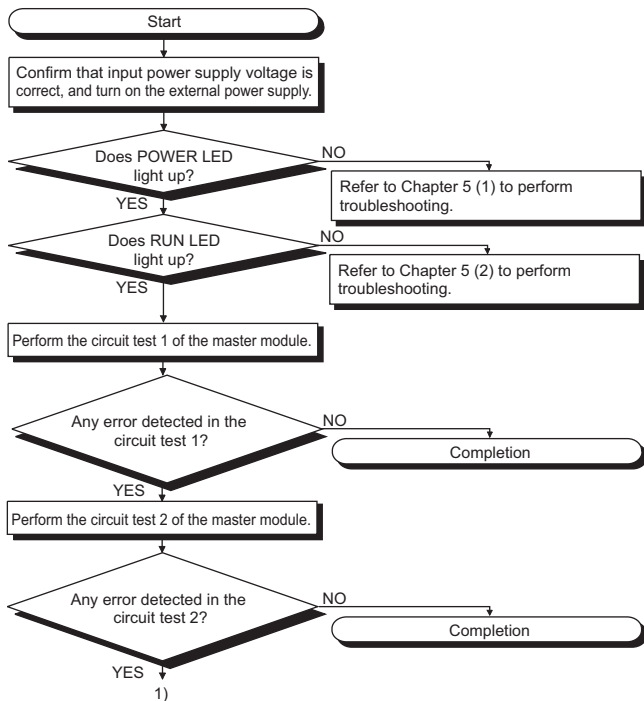

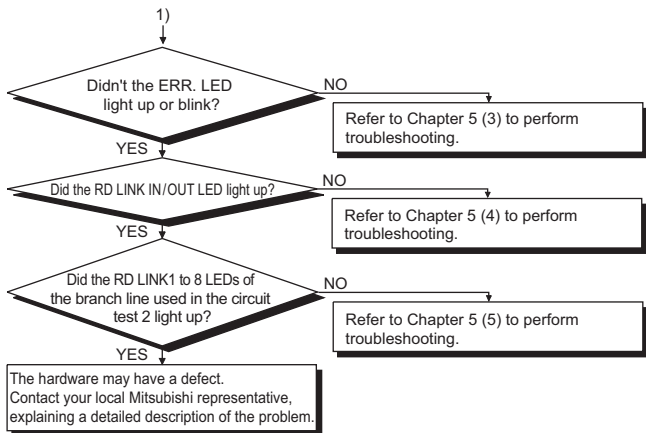

5. TROUBLESHOOTING

This section describes the measures when a trouble occurred in the AJ65BTS-RPH.

Perform the troubleshooting indicated in the reference section.

No.*1	Problem	Reference section
1	The POWER LED is not lit while the module power is ON.	(1) in this chapter
2	The RUN LED is not lit while the module power is ON.	(2) in this chapter
3	The ERR. LED lighted up or blinked.	(3) in this chapter
4	The RD LINK IN/OUT LED does not light up during data link.	(4) in this chapter
5	The RD LINK 1 to 8 LEDs corresponding to the data linking branch lines do not light up.	(5) in this chapter

*1 If more than one problem occurred simultaneously, perform the troubleshooting in order of the item numbers.

(1) The POWER LED is not lit while the module power is ON

Troubleshooting is shown below for the case that the POWER LED is not lit while the module power is ON.

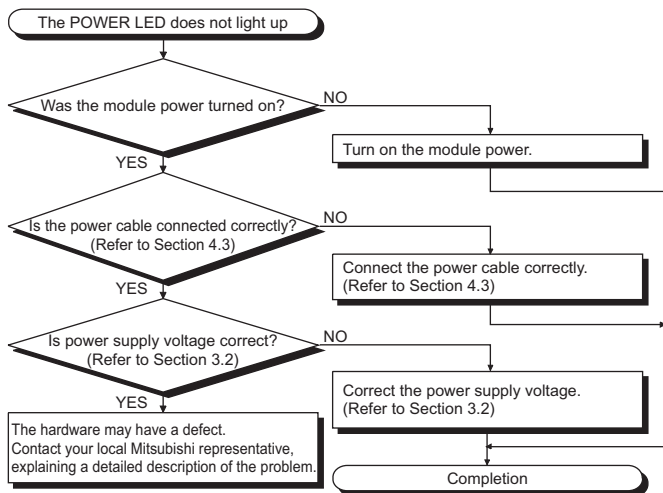

- (2) The RUN LED is not lit while the module power is ON.
If the RUN LED is not lit while the module power is ON, turn off and on the module again.
If the RUN LED is not lit after the module power is reapplied, the hardware may be faulty. Please contact your local Mitsubishi representative.

- (3) The ERR. LED lights up or blinks.
Troubleshooting is shown below for the case that the ERR. LED lights up or blinks.

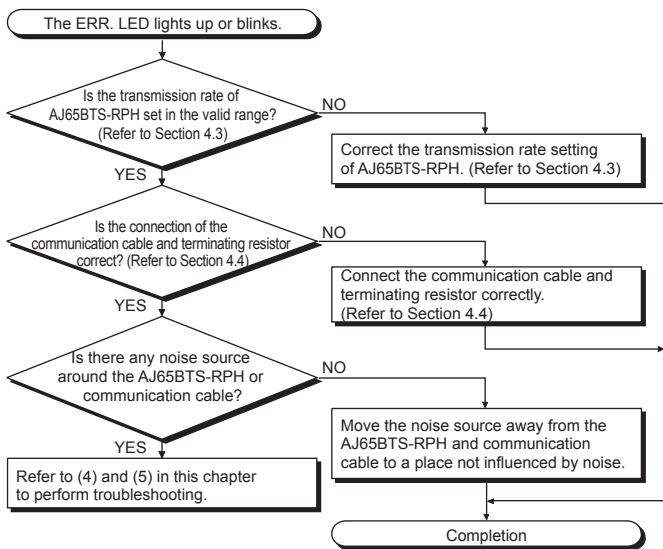

(4) The RD LINK IN/OUT LED is not lit during data link.

This section describes troubleshooting for the case that the RD LINK IN/OUT LED is not lit.

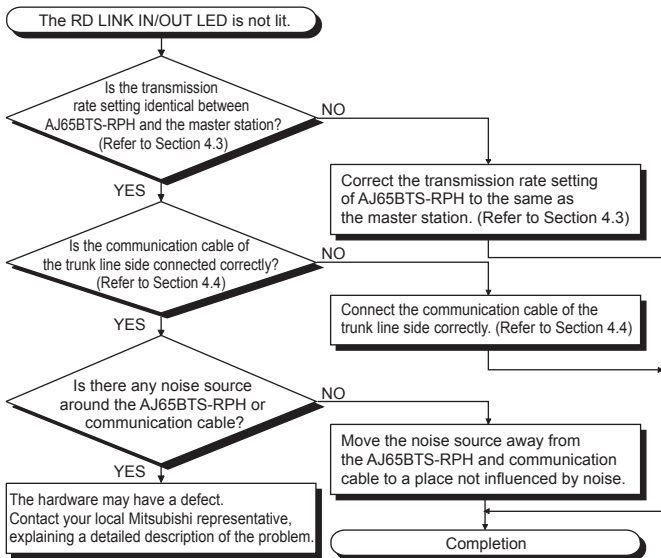

(5) The RD LINK 1 to 8 LEDs corresponding to the data linking branch lines are not lit.

This section describes troubleshooting when the RD LINK 1 to 8 LEDs corresponding to the data linking branch lines are not lit.

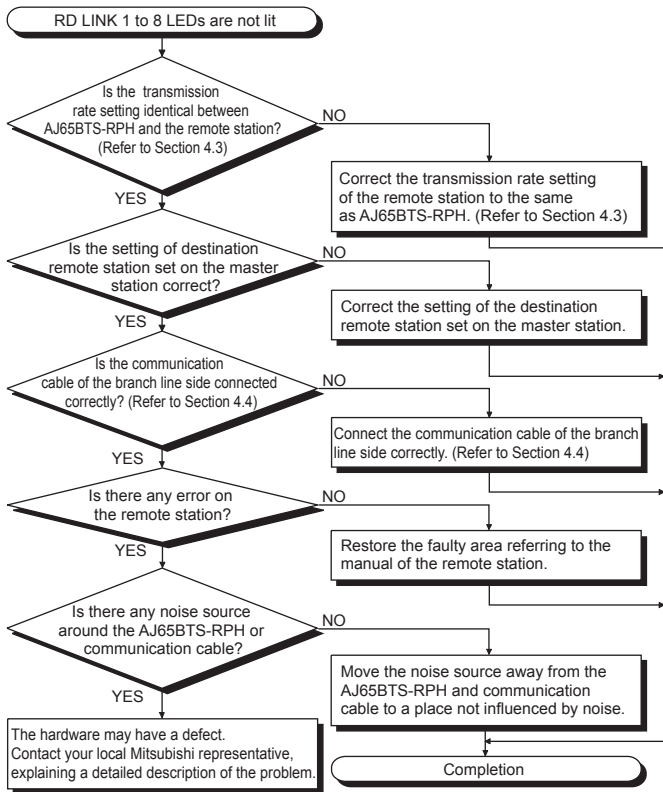

6. EXTERNAL DIMENSIONS

The external dimensions of AJ65BTS-RPH module is shown below.

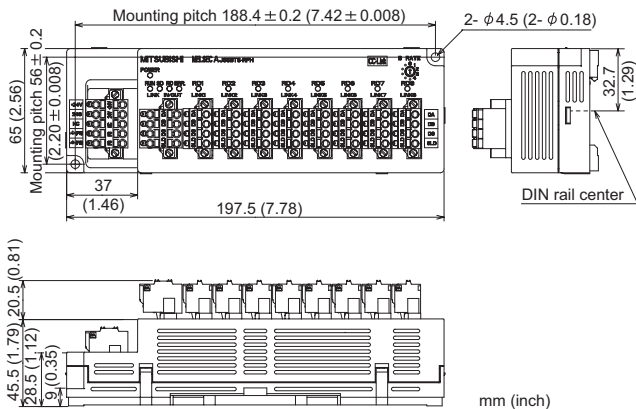

WARRANTY

Mitsubishi will not be held liable for damage caused by factors found not to be the cause of Mitsubishi; machine damage or lost profits caused by faults in the Mitsubishi products; damage, secondary damage, accident compensation caused by special factors unpredictable by Mitsubishi; damages to products other than Mitsubishi products; and to other duties.

Country/Region	Sales office/Tel	Country/Region	Sales office/Tel
U.S.A	Mitsubishi Electric Automation Inc. 500 Corporate Woods Parkway Vernon Hills, IL 60061, U.S.A. Tel : +1-847-478-2100	China	Mitsubishi Electric Automation (China) Ltd. 4/F Zhi Fu Plazz, No.80 Xin Chang Road, Shanghai 200003, China Tel : +86-21-6120-0808
Brazil	MELCO-TEC Rep. Com.e Assessoria Tecnica Ltda. Rua Correia Dias, 184, Edificio Paraiso Trade Center-8 andar Paraiso, Sao Paulo, SP Brazil Tel : +55-11-5908-8331	Taiwan	Setsuyo Enterprise Co., Ltd. 6F No.105 Wu-Kung 3rd.Rd, Wu-Ku Hsiang, Taipei Hsine, Taiwan Tel : +886-2-2299-2499
Germany	Mitsubishi Electric Europe B.V. German Branch Gothaer Strasse 8 D-40880 Ratingen, GERMANY Tel : +49-2102-486-0	Korea	Mitsubishi Electric Automation Korea Co., Ltd. 1480-6, Gayang-dong, Gangseo-ku Seoul 157-200, Korea Tel : +82-2-3660-9552
U.K	Mitsubishi Electric Europe B.V. UK Branch Travellers Lane, Hatfield, Hertfordshire., AL10 8XB, U.K. Tel : +44-1707-276100	Singapore	Mitsubishi Electric Asia Pte, Ltd. 307 Alexandra Road #05-01/02, Mitsubishi Electric Building, Singapore 159943 Tel : +65-6470-2480
Italy	Mitsubishi Electric Europe B.V. Italian Branch Centro Dir. Colleoni, Pal. Perseo-Ingr.2 Via Paracelso 12, I-20041 Agrate Brianza., Milano, Italy Tel : +39-039-60531	Thailand	Mitsubishi Electric Automation (Thailand) Co., Ltd. Bang-Chan Industrial Estate No.111 Moo 4, Serithai Rd, T.Kannayao, A.Kannayao, Bangkok 10230 Thailand Tel : +66-2-517-1326
Spain	Mitsubishi Electric Europe B.V. Spanish Branch Carretera de Rubi 76-80, E-08190 Sant Cugat del Valles, Barcelona, Spain Tel : +34-93-565-3131	Indonesia	P.T. Autoteknindo Sumber Makmur Muara Karang Selatan, Block A/Utara No.1 Kav. No.11 Kawasan Industri Pergudangan Jakarta - Utara 14440, P.O.Box 5045 Jakarta, 11050 Indonesia Tel : +62-21-6630833
France	Mitsubishi Electric Europe B.V. French Branch 25, Boulevard des Bouvets, F-92741 Nanterre Cedex, France Tel : +33-1-5568-5568	India	Messung Systems Pvt, Ltd. Electronic Sadan NO:III Unit No15, M.I.D.C Bhosari, Pune-411026, India Tel : +91-20-2712-3130
South Africa	Circuit Breaker Industries Ltd. Private Bag 2016, ZA-1600 Isando, South Africa Tel : +27-11-928-2000	Australia	Mitsubishi Electric Australia Pty. Ltd. 348 Victoria Road, Rydalmere, N.S.W 2116, Australia Tel : +61-2-9684-7777

MITSUBISHI ELECTRIC CORPORATION

HEAD OFFICE : TOKYO BUILDING, 2-7-3 MARUNOUCHI, CHIYODA-KU, TOKYO 100-8310, JAPAN
NAGOYA WORKS : 1-14, YADA-MINAMI 5-CHOME, HIGASHI-KU, NAGOYA, JAPAN

When exported from Japan, this manual does not require application to the Ministry of Economy, Trade and Industry for service transaction permission.