

mitsubishi electric

E1151

Installation manual

English

Installation manual for the E1000 series operator terminals

Foreword

The E1000 operator terminal is developed to satisfy the demands of human-machine communication. Built-in functions such as displaying and controlling text, dynamic indication, time channels, alarm and recipe handling are included.

The operator terminal work, for the most part, is in an object-oriented way, making it easy to understand and use. The configuration operation of the terminal is made in a personal computer, using the configuration tool E-Designer. The project is then transferred and stored in the operator terminal.

The operator terminal can be connected to many types of automation equipment, such as PLCs, servos or drives. In this manual the expression “the controller” is used as a general term for the connected equipment.

This manual explains how to install the operator terminal. Please refer to the reference manual for further information.

© Mitsubishi Electric, MA00780A, 2006-04

The information in this document is subject to change without notice and is provided as available at the time of printing. The manufacturer reserves the right to change any information without updating this publication. The manufacturer assumes no responsibility for any errors that may appear in this document. Read the entire installation manual prior to installing and using this equipment. Only qualified personnel may install, operate or repair this equipment. The manufacturer is not responsible for modified, altered or renovated equipment. Because the equipment has a wide range of applications, users must acquire the appropriate knowledge to use the equipment properly in their specific applications. Persons responsible for the application and the equipment must themselves ensure that each application is in compliance with all relevant requirements, standards and legislation in respect to configuration and safety. Only parts and accessories manufactured according to specifications set by The manufacturer may be used. THE MANUFACTURER SHALL NOT BE LIABLE TO ANYONE FOR ANY DIRECT, INDIRECT, SPECIAL, INCIDENTAL OR CONSEQUENTIAL DAMAGES RESULTING FROM THE INSTALLATION, USE OR REPAIR OF THIS EQUIPMENT, WHETHER ARISING IN TORT, CONTRACT, OR OTHERWISE. BUYER'S SOLE REMEDY SHALL BE THE REPAIR, REPLACEMENT, OR REFUND OF PURCHASE PRICE, AND THE CHOICE OF THE APPLICABLE REMEDY SHALL BE AT THE SOLE DISCRETION OF THE MANUFACTURER.

Table of Contents

1 Safety Precautions	1-1
1.1 UL Installation.....	1-1
1.2 General	1-1
1.3 During Use	1-1
1.4 Service and Maintenance.....	1-2
1.5 Dismantling and Scrapping.....	1-2
2 Installation	2-1
2.1 Space Requirements	2-1
2.2 Installation Process.....	2-1
2.2.1 Mode Switches	2-3
2.2.2 Connections to the Controller	2-3
2.2.3 Other Connections and Peripherals	2-3
3 Technical Data	3-1
4 Chemical Resistance	4-1
4.1 Metal Casing.....	4-1
4.2 Touch Screen and Overlay	4-1
4.2.1 Autotex F250.....	4-1
4.2.2 Touch Screen Surface	4-2
4.2.3 Autoflex EB	4-3
5 Operator Terminal Drawings	5-1
5.1 Communication Ports.....	5-1
5.2 E1151 Outline.....	5-2

1 Safety Precautions

Both the installer and the owner and/or operator of the operator terminal must read and understand this installation manual.

1.1 UL Installation

Power, input and output (I/O) wiring must be in accordance with Class 1, Division 2 wiring methods (Article 501-4 (b) of the National Electric Code, NFPA 70) and in accordance with the authority having jurisdiction.

1.2 General

- Only qualified personnel may install or operate the operator terminal.
- The operator terminal must be installed according to the installation instructions.
- The operator terminal is designed for stationary installation on a plane surface, where the following conditions are fulfilled:
 - no high explosive risks
 - no strong magnetic fields
 - no direct sunlight
 - no large, sudden temperature changes
- Never allow fluids, metal filings or wiring debris to enter any openings in the operator terminal. This may cause fire or electrical shock.
- The operator terminal fulfills the requirements of article 4 of EMC directive 89/336/EEC.
- Storing the operator terminal where the temperature is lower/higher than recommended in this manual can cause the LCD display liquid to congeal/become isotopic.
- The LCD display liquid contains a powerful irritant. In case of skin contact, wash immediately with plenty of water. In case of eye contact, hold the eye open, flush with plenty of water and get medical attention.
- The supplier is not responsible for modified, altered or reconstructed equipment.
- Use only parts and accessories manufactured according to specifications of the supplier.
- Peripheral equipment must be appropriate for the application and location.
- The figures in this manual serves an illustrative purpose. Because of the many variables associated with any particular installation, the supplier cannot assume responsibility for actual use based on the figures.
- The supplier neither guarantees that the operator terminal is suitable for your particular application, nor assumes responsibility for your product design, installation or operation.

1.3 During Use

- Keep the operator terminal clean.
- Emergency stop and other safety functions may not be controlled from the operator terminal.
- Do not use too much force or sharp objects when touching the keys, display etc.

1.4 Service and Maintenance

- Only qualified personnel should carry out repairs.
- The agreed warranty applies.
- Before carrying out any cleaning or maintenance operations, disconnect the equipment from the electrical supply.
- Clean the display and surrounding front cover with a soft cloth and mild detergent.
- Replacing the battery incorrectly may result in explosion. Only use batteries recommended by the supplier.

1.5 Dismantling and Scrapping

- The operator terminal or parts thereof shall be recycled according to local regulations.
- The following components contain substances that might be hazardous to health and the environment: lithium battery, electrolytic capacitor and display.

2 Installation

2.1 Space Requirements

- Installation plate thickness: 1.5 - 9.0 mm (0.06 - 0.35 inch)
- Space requirements when installing the operator terminal:

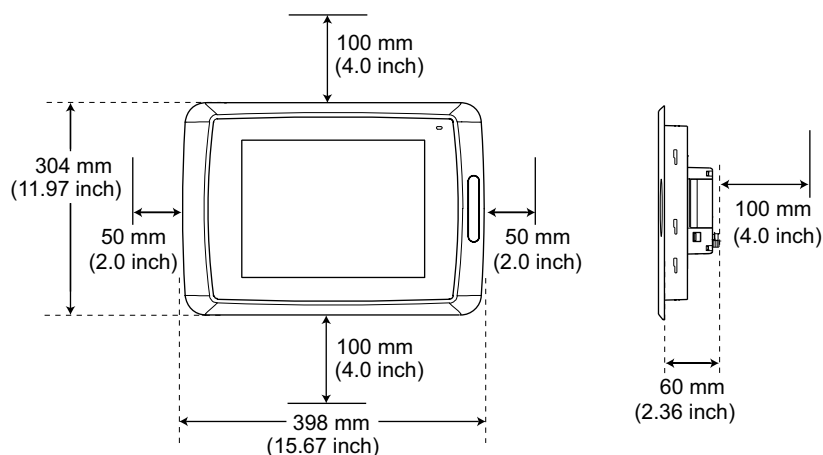

Caution

The openings on the enclosure are for air convection. Do not cover these openings.

2.2 Installation Process

1. Unpack and check the delivery. If damage is found, notify the supplier.

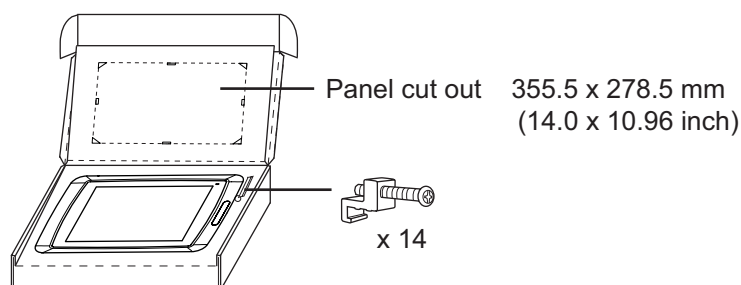

Note:

Place the operator terminal on a stable surface during installation. Dropping it or letting it fall may cause damage.

2. Place the panel cut out where the operator terminal is to be situated, draw along the outer sides of the holes and cut according to the markings.

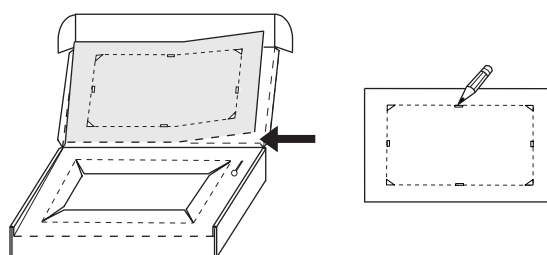

- Secure the operator terminal in position, using all the fastening holes and the provided brackets and screws:

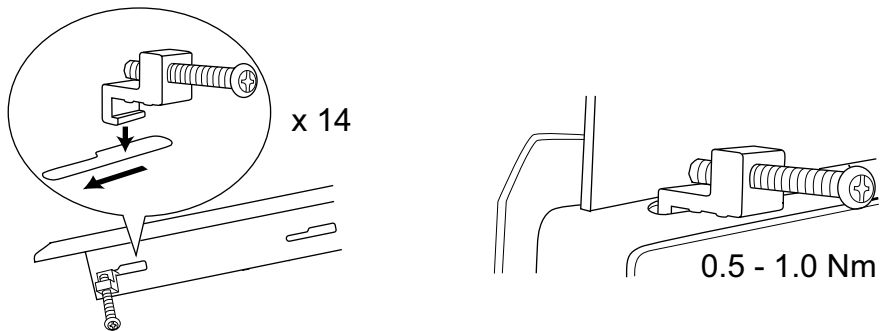

- Connect the cables in the specified order.

- Caution**

Ensure that the operator terminal and the controller system have the same electrical grounding (reference voltage level), otherwise errors in communication may occur.
- Use an M5 screw and a grounding conductor (as short as possible) with a cross-section of minimum 2.5 mm².
- Caution**

 - Use only shielded communication cables.
 - Separate high voltage cables from signal and supply cables.
- Caution**

 - The operator terminal must be brought to ambient temperature before it is started up. If condensation forms, ensure that the operator terminal is dry before connecting it to the power outlet.
 - Ensure that the voltage and polarity of the power source is correct.

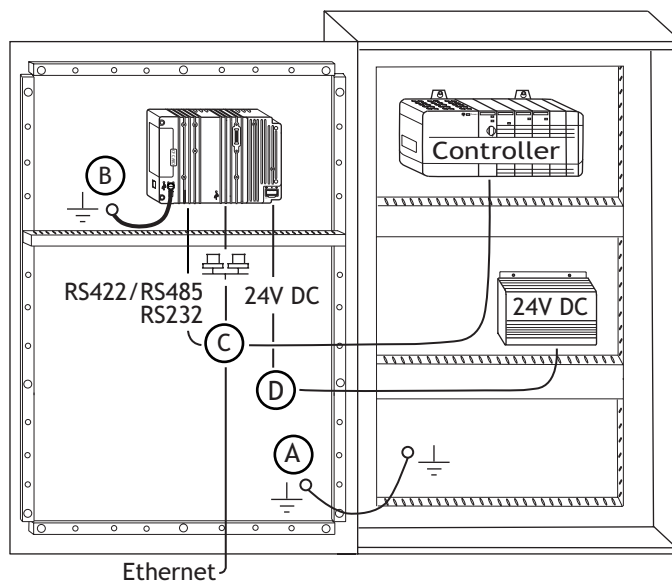

- Carefully remove the laminated film over the operator terminal display, to avoid static electricity that could damage the terminal.

2.2.1 Mode Switches

All mode switches must be in OFF position during operator terminal use.

The mode switches should not be touched unless by qualified personell.

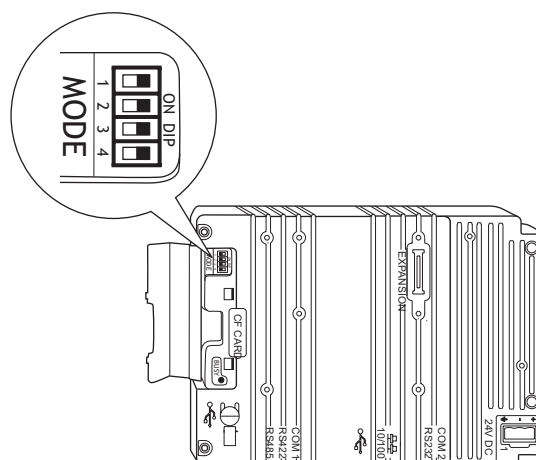

2.2.2 Connections to the Controller

For information about the cables to be used when connecting the operator terminal to the controller, please refer to the help file for the driver in question.

2.2.3 Other Connections and Peripherals

Cables, peripheral equipment and accessories must be suitable for the application and its environment. For further details or recommendations, please refer to the supplier.



Caution

When using a compact flash card, do not remove the card when the busy indicator is illuminated.

3 Technical Data

Parameter	E1151
Front panel, W x H x D	398 x 304 x 6 mm
Mounting depth	60 mm (160 mm including clearance)
Front panel seal	IP 66
Rear panel seal	IP 20
Keyboard material/ Front panel	Touch screen: Polyester on glass *, 1 million finger touch operations. Overlay: Autotex F250 *.
Reverse side material	Powder-coated aluminum
Weight	3.7 kg
Serial port RS422/ RS485	25-pin D-sub contact, chassis-mounted female with standard locking screws 4-40 UNC.
Serial port RS232C	9-pin D-sub contact, male with standard locking screws 4-40 UNC.
Ethernet	Shielded RJ 45
USB	Host type A (USB 1.1), max output current 500mA Device type B (USB 1.1)
CF-slot	Compact flash, type I and II
Flash memory for application	12 MB (incl. fonts)
Real time clock	±20 PPM + error because of ambient temperature and supply voltage. Total max error: 1 min/month at 25 °C Minimum life of the real time clock battery: 3 years Temperature coefficient: 0.004 ppm/°C ²
Power consumption at rated voltage	Normal: 1.2 A Maximum: 1.7 A
Display	TFT-LCD. 1024 x 768 pixels, 64K color. CCFL backlight lifetime at the ambient temperature of +25 °C: >35,000 h.
Active area of display, W x H	304.1 x 228.1 mm
Fuse	Internal DC fuse, 3.15 AT, 5 x 20 mm
Power supply	+24V DC (20 - 30V DC). 3-pin jack connection block. CE: The power supply must conform with the requirements for SELV or PELV according to IEC 950 or IEC 742. UL: The power supply must conform with the requirements for class II power supplies.
Ambient temperature	Vertical installation: 0 ° to +50 °C Horizontal installation: 0 ° to +40 °C
Storage temperature	-20 ° to +70 °C
Relative humidity	5 - 85 % non-condensed
EMC tests on the operator terminal	The operator terminal conforms with the essential protection requirements in article 4 of the directive 89/336/EEC. Noise tested according to EN61000-6-4 emission and EN61000-6-2 immunity.
UL, cUL approvals (when product or packing is marked)	UL 1604 Class I, Div 2 / UL 508 / UL 50 4x indoor use only
DNV	Yes
NEMA	4x indoor use only

* See section [Chemical Resistance](#)

4 Chemical Resistance

4.1 Metal Casing

The frame and casing material is powder-coated aluminum. This powder paint withstands exposure of up to 24 hours duration to the following chemicals without visible change:

Ammonia 25%	Isopropyl alcohol	Nitric acid 3%
De-ionized water	Tap water	Chlorhydric acid 10%
Butanol	Cooling liquid 50%	Washer fluid 33%
Citric acid 10%	Ligroin	Sulphuric acid 20%
Diesel	Cooking oil	Turpentine
Ethanol 99.5% denaturated	Lactic acid 10%	Urea saturated
FAM-Normal petrol	Sodium di-chromate saturated	Hydroperoxide 3%
Alcohol 95%	Caustic soda 5%	Acetic acid 10%
Phosphoric acid 43%	Sodium hypochlorite solution	Alu-cleaner
Glycol	Sodium carbonate 10%	-
Industrial petrol	Sodium chloride 20%	-

4.2 Touch Screen and Overlay

4.2.1 Autotex F250

Autotex F250 covers the overlay surrounding the touch screen.

Solvent Resistance

Autotex F250 withstands exposure of more than 24 hours duration under DIN 42 115 Part 2 to the following chemicals without visible change:

Potassium ferrocyanide/ ferricyanide	Sodium hypchlorite <20% (bleach)	1.1.1. Trichloroethane (Genklene)
Cyclohexanol	Acetaldehyde	Ethylacetate
Diacetone alcohol	Aliphatic hydrocarbons	Diethyl ether
Glycol	Toluene	N-Butyl acetate
Isopropanol	Xylene	Amylacetate
Glycerine	White spirit	Butycellosolve
Methanol	Formic acid <50%	Ether
Triacetin	Acetic acid <50%	MIBK
Dowanol DRM/PM	Phosphoric acid <30%	Cutting oil
Acetone	Hydrochloric acid <36%	Potassium carbonate
Metyl ethyl ketone	Nitric acid <10%	Washing powders
Dioxan	Trichloroacetic acid <50%	Fabric conditioner
Cyclohexanone	Sulphuric acid <10%	Ferric chloride
Ethanol	Formaldehyde 37% - 42%	Ferrous chlorid
Isophorone	Potassium hydroxide <30%	Dibutyl Phthalate

Ammonia <40%	Linseed oil	Dioctyl Phthalate
Caustic soda <40%	Paraffin oil	Sodium carbonate
Hydrogen peroxide <25%	Blown castor oil	Petrol
Alkalicarbonate	Silicone oil	Teepol
Bichromate	Turpentine substitute	Water
Diesel oil	Univeral brake fluid	Sea water
Acetonitrile	Decon	-
Sodium bisulphate	Aviation fuel	-

Autotex withstands DIN 42 115 Part 2 exposure of up to 1 hour duration to glacial acetic acid without visible change.

Autotex is not resistant to high pressure steam at over 100 °C or the following chemicals:

Concentrated mineral acids	Benzyl alcohol
Concentrated caustic solution	Mehylene chloride

Autotex withstands 24 hours exposure to the following reagents at 50 °C without visible staining:

Top Job	Grape Juice	Ariel	Ajax
Jet Dry	Milk	Persil	Vim
Gumption	Coffee	Wisk	Domestos
Fantastic	-	Lenor	Vortex
Formula 409	-	Downey	Windex

Very slight discoloration was noted under critical viewing conditions with the following materials:

Tomato juice	Tomato ketchup	Lemon juice	Mustard
--------------	----------------	-------------	---------

Outdoor Use

In common with all polyester based films Autotex F250 is not suitable for use in conditions of long term exposure to direct sunlight.

4.2.2 Touch Screen Surface

The touch screen surface on the operator terminal withstands exposure to the following solvents without visible change:

Solvents	Time
Acetone	10 minutes
Isopropanol	10 minutes
Toulene	5 hours

4.2.3 Autoflex EB

It is recommended to use the Autoflex EB touch display protection film, that can be ordered from the supplier.

Solvent Resistance

Autoflex EB withstands exposure of more than 24 hours duration under DIN 42 115 Part 2 to the following chemicals without visible change:

Potassium ferrocyanide/ ferricyanide	Sodium hypchlorite <20% (bleach)	1.1.1. Trichloroethane (Genklene)
Cyclohexanol	Acetaldehyde	Ethylacetate
Diacetone alcohol	Aliphatic hydrocarbons	Diethyl ether
Glycol	Toluene	N-Butyl acetate
Isopropanol	Xylene	Amylacetate
Glycerine	White spirit	Butyrcellosolve
Methanol	Formic acid <50%	Ether
Triacetin	Acetic acid <50%	MIBK
Dowanol DRM/PM	Phosphoric acid <30%	Cutting oil
Acetone	Hydrochloric acid <36%	Potassium carbonate
Metyl ethyl ketone	Nitric acid <10%	Washing powders
Dioxan	Trichloroacetic acid <50%	Fabric conditioner
Cyclohexanone	Sulphuric acid <10%	Ferric chloride
Ethanol	Formaldehyde 37% - 42%	Ferrous chlorid
Isophorone	Potassium hydroxide <30%	Dibutyl Phthalate
Ammonia <40%	Linseed oil	Diocetyl Phthalate
Caustic soda <40%	Paraffin oil	Sodium carbonate
Hydrogen peroxide <25%	Blown castor oil	Petrol
Alkalicarbonat	Silicone oil	Teepol
Bichromate	Turpentine substitute	Water
Diesel oil	Univeral brake fluid	Sea water
Acetonitrile	Decon	-
Sodium bisulphate	Aviation fuel	-

Autoflex withstands DIN 42 115 Part 2 exposure of up to 1 hour duration to glacial acetic acid without visible change.

Autoflex is not resistant to high pressure steam at over 100 °C or the following chemicals:

Concentrated mineral acids	Benzyl alcohol
Concentrated caustic solution	Mehylene chloride

Autoflex withstands 24 hours exposure to the following reagents at 50 °C without visible staining:

Top Job	Grape Juice	Ariel	Ajax
Jet Dry	Milk	Persil	Vim
Gumption	Coffee	Wisk	Domestos
Fantastic	-	Lenor	Vortex
Formula 409	-	Downey	Windex

Very slight discoloration was noted under critical viewing conditions with the following materials:

Tomato juice	Tomato ketchup	Lemon juice	Mustard
--------------	----------------	-------------	---------

Outdoor Use

In common with all polyester based films Autoflex EB is not suitable for use in conditions of long term exposure to direct sunlight.

5 Operator Terminal Drawings

5.1 Communication Ports

RS-232

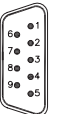

Pin no	Signal	Signal Name	Signal direction
1	DCD	Data Carrier Detect	Input
2	RD	Receive Data	Input
3	TD	Transmit Data	Output
4	DTR	Data Terminal Ready	Output
5	SG	Signal Ground	-
6	DSR	Data Set Ready	Input
7	RTS	Request To Send	Output
8	CTS	Clear To Send	Input
9	RI	Ring Indicator	Input

D-sub
9-pin Male

RS-422/485

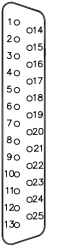

Pin no	RS-422		RS-485	
	Signal	Signal direction	Signal	Signal direction
2	TxD+	Output	Tx/Rx+	In/Output
15	TxD-	Output	Tx/Rx-	In/Output
3	RxD+	Input		
16	RxD-	Input		
4	RTS+	Output		
17	RTS-	Output		
5	CTS+	Input		
18	CTS-	Input		
20	1)			
21	1)			
6	Do not use		2) Bus termination	4) Connect to pin no.19 for bus-termination.
19	Do not use		3) Bus termination	See above
7,8	0V		0V	
14	+5V <100mA	Output	+5V <100mA	Output

D-sub
25-pin Female

- 1) Pin no 20 connected to pin no 21 internal in the terminal
- 2) Directly connected internally to pin no. 2 (Tx/Rx+).
- 3) Connected to pin no. 15 (Tx/Rx-) internally via a 120ohm 1/4W resistor.
- 4) NOTE! Only the first and the last unit on the bus should be terminated.

USB

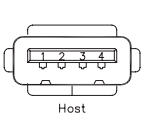

Pin no	Signal	Signal direction
1	VBUS	-
2	D-	In/Output
3	D+	In/Output
4	GND	-

Host Device

Frame connected to chassis.

Ethernet

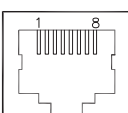

Pin no	Signal	Signal direction
1	Tx+	Output
2	Tx-	Output
3	Rx+	Input
6	Rx-	Input
4,5,7,8	GND	

Drawing No. S-5005, Date 2004-10-27

5.2 E1151 Outline

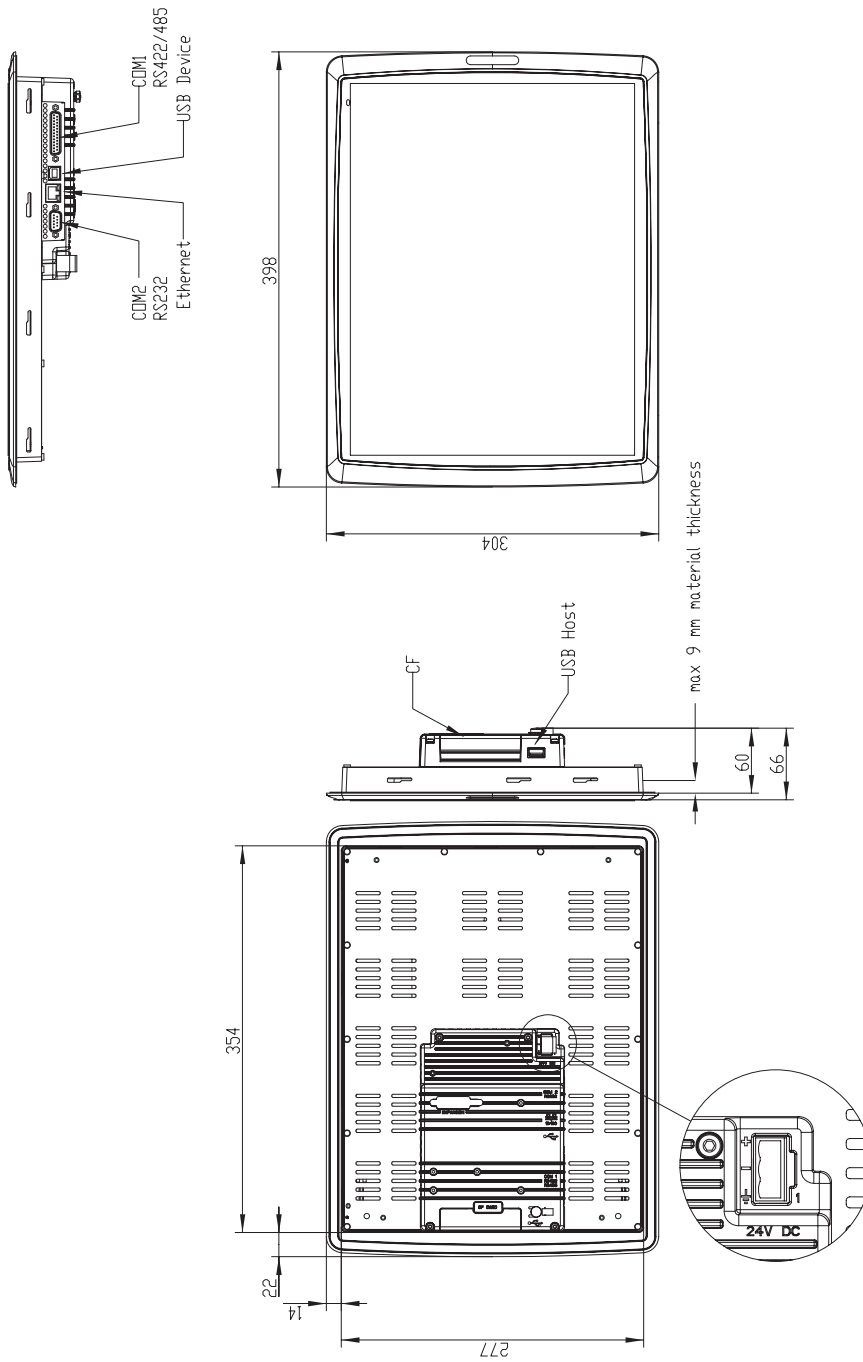

Drawing No. S-5141, Date 2004-10-26

MITSUBISHI ELECTRIC

Mitsubishi Electric Automation, Inc.
500 Corporate Woods Parkway
Vernon Hills, IL 60061, USA

Mitsubishi Electric Europe B.V.
Gothaer Strasse 8
D-40880 Ratingen, Germany