

MITSUBISHI *Changes for the Better*

GT1155-QTBDQ, GT1155-QTBDA,
GT1155-QSBDQ, GT1155-QSBDA,
GT1150-QLBDQ, GT1150-QLBDA

**GT11 Dedicated to Bus Connection
General Description**

MODEL	GT11-BUS-U-HW-E
MODEL CODE	1D7M70
IB(NA)-0800385ENG-F(1105)MEE	

GOT1000

This manual describes the part names, dimensions, mounting, and specifications of the product. Before use, read this manual and manuals of relevant products fully to acquire proficiency in handling and operating the product. Make sure to learn all the product information, safety information, and precautions.

And, store this manual in a safe place so that you can take it out and read it whenever necessary. Always forward it to the end user.

Registration
The company name and the product name to be described in this manual are the registered trademarks or trademarks of each company.

Effective November 2007
Specifications are subject to change without notice.

© 2007 Mitsubishi Electric Corporation
Japanese Manual Version IB-0800384-F

Safety Precaution (Read these precautions before using.)
Before using this product, please read this manual and the relevant manuals introduced in this manual carefully and pay full attention to safety to handle the product correctly.
The precautions given in this manual are concerned with this product.
In this manual, the safety precautions are ranked as "DANGER" and "CAUTION".

DANGER	Indicates that incorrect handling may cause hazardous conditions, resulting in death or severe injury.
CAUTION	Indicates that incorrect handling may cause hazardous conditions, resulting in medium or slight personal injury or physical damage.

Depending on circumstances, procedures indicated by "CAUTION" may also be linked to serious results.
In any case, it is important to follow the directions for usage.

DESIGN PRECAUTIONS **DANGER**

- Some failures of the GOT or cable may keep the outputs on or off. An external monitoring circuit should be provided to check for output signals which may lead to a serious accident. Not doing so can cause an accident due to false output or malfunction.
- If a communication fault (including cable disconnection) occurs during monitoring on the GOT, communication between the GOT and programmable controller CPU is suspended and the GOT becomes inoperative. The programmable controller CPU goes down, and then the GT1155-QTBDQ, GT1155-QTBDA, GT1155-QSBDQ, GT1155-QSBDA, GT1150-QLBDQ, and GT1150-QLBDA become inoperative. A system where the GOT is used should be configured to perform any significant operation to the system by using the switches of a device other than the GOT on the assumption that a GOT communication fault will occur. Not doing so can cause an accident due to false output or malfunction.
- Do not use the GOT as the warning device that may cause a serious accident. An independent and redundant hardware or mechanical interlock is required to configure the device that displays and outputs serious warning. Failure to observe this instruction may result in an accident due to incorrect output or malfunction.
- Incorrect operation of the touch switch(es) may lead to a serious accident if the GOT backlight is gone out. When the GOT backlight goes out, the POWER LED flickers (green/orange) and the display section turns black and causes the monitor screen to appear blank, while the input of the touch switch(es) remains active. This may cause an operator in thinking that the GOT is in "screensaver" mode, who then tries to release the GOT from this mode by touching the display section, which may cause a touch switch to operate. Note that the following occurs on the GOT when the backlight goes out.
 - The POWER LED flickers (green/orange) and the monitor screen appears blank

DESIGN PRECAUTIONS **CAUTION**

- Do not bundle the control and communication cables with main-circuit, power or other wiring. Run the above cables separately from such wiring and keep them a minimum of 100mm (3.94in.) apart. Not doing so noise can cause a malfunction.
- Do not press the GOT display section with a pointed material as a pen or driver. Doing so can result in a damage or failure of the display section.
- Turn on the controllers and the network devices to be ready for communication before they communicate with the GOT. Failure to do so can cause a communication error on the GOT.

MOUNTING PRECAUTIONS **DANGER**

- Be sure to shut off all phases of the external power supply used by the system before mounting or removing the GOT to/from the panel. Not doing so can cause the unit to fail or malfunction.

MOUNTING PRECAUTIONS **CAUTION**

- Use the GOT in the environment that satisfies the general specifications described in this manual. Not doing so can cause an electric shock, fire, malfunction or product damage or deterioration.
- When mounting the GOT to the control panel, tighten the mounting screws in the specified torque range. Undertightening can cause the GOT to drop, short circuit or malfunction. Overtightening can cause a drop, short circuit or malfunction due to the damage of the screws or the GOT.
- When inserting/removing a CF card into/from the GOT, turn the CF card access switch off in advance. Failure to do so may corrupt data within the CF card.
- When inserting a CF card into the GOT, push it into the insertion slot until the CF card eject button will pop out. Failure to do so may cause a malfunction due to poor contact.
- When removing a CF card from the GOT, make sure to support the CF card by hand, as it may pop out. Failure to do so may cause the CF card to drop from the GOT and break.
- Remove the protective film of the GOT. When the user continues using the GOT with the protective film, the film may not be removed.
- Operate and store the GOT in environments without direct sunlight, high temperature, dust, humidity, and vibrations.
- When using the GOT in the environment of oil or chemicals, use the protective cover for oil. Failure to do so may cause failure or malfunction due to the oil or chemical entering into the GOT.

WIRING PRECAUTIONS **DANGER**

- Be sure to shut off all phases of the external power supply used by the system before wiring. Failure to do so may result in an electric shock, product damage or malfunctions.

WIRING PRECAUTIONS **CAUTION**

- Always ground the FG terminal of the GOT power to the protective ground conductor. Failure to do so may cause electric shocks and malfunctions.
- Terminal screws which are not to be used must be tightened always at torque 0.5 to 0.8 N·m. Otherwise there will be a danger of short circuit against the solderless terminals.
- Use applicable solderless terminals and tighten them with the specified torque. If any solderless spade terminal is used, it may be disconnected when the terminal screw comes loose, resulting in failure, less terminals.
- Correctly wire the GOT power supply section after confirming the rated voltage and terminal arrangement of the product. Not doing so can cause a fire or failure.
- Tighten the terminal screws of the GOT power supply section in the specified torque range. Undertightening can cause a short circuit or malfunction. Overtightening can cause a short circuit or malfunction due to the damage of the screws or the GOT.
- Exercise care to avoid foreign matter such as chips and wire offcuts entering the GOT. Not doing so can cause a fire, failure or malfunction.
- The module has an ingress prevention label on its top to prevent foreign matter, such as wire offcuts, from entering the module during wiring. Do not peel this label during wiring. Before starting system operation, be sure to peel this label because of heat dissipation.
- Plug the communication cable into the connector of the connected unit and tighten the mounting and terminal screws in the specified torque range. Undertightening can cause a short circuit or malfunction. Overtightening can cause a short circuit or malfunction due to the damage of the screws or unit.
- Plug the QnA/ACPU/Motion controller (A series) bus connection cable by inserting it into the connector of the connected unit until it "clicks". After plugging, check that it has been inserted snugly. Not doing so can cause a malfunction due to a contact fault.

TEST OPERATION PRECAUTIONS **DANGER**

- Before performing the test operations of the user creation monitor screen (such as turning ON or OFF bit device, changing the word device current value, changing the settings or current values of the timer or counter, and changing the buffer memory current value), read through the manual carefully and make yourself familiar with the operation method. During test operation, never change the data of the devices which are used to perform significant operation for the system. False output or malfunction can cause an accident.

STARTUP/MAINTENANCE PRECAUTIONS **DANGER**

- When power is on, do not touch the terminals. Doing so can cause an electric shock or malfunction.
- Correctly connect the battery connector. Do not charge, disassemble, heat, short-circuit, solder, or throw the battery into the fire. Doing so will cause the battery to produce heat, explode, or ignite, resulting in injury and fire.
- Before starting cleaning or terminal screw retightening, always switch off the power externally in all phases. Not switching the power off in all phases can cause a unit failure or malfunction. Undertightening can cause a short circuit or malfunction. Overtightening can cause a short circuit or malfunction due to the damage of the screws or unit.

STARTUP/MAINTENANCE PRECAUTIONS **CAUTION**

- Do not disassemble or modify the unit. Doing so can cause a failure, malfunction, injury or fire.
- Do not touch the conductive and electronic parts of the unit directly. Doing so can cause a unit malfunction or failure.
- The cables connected to the unit must be run in ducts or clamped. Not doing so can cause the unit or cable to be damaged due to the dangling, motion or accidental pulling of the cables or can cause a malfunction due to a cable connection fault.
- When unplugging the cable connected to the unit, do not hold and pull the cable portion. Doing so can cause the unit or cable to be damaged or can cause a malfunction due to a cable connection fault.
- Do not drop the module or subject it to strong shock. A module damage may result.
- Do not drop or give an impact to the battery mounted to the unit. Doing so may damage the battery, causing the battery fluid to leak inside the battery. If the battery is dropped or given an impact, dispose of it without using.
- Before touching the unit, always touch grounded metal, etc. to discharge static electricity from human body, etc. Not doing so can cause the unit to fail or malfunction.
- Replace battery with GT11-50BAT by Mitsubishi electric Co. only. Use of another battery may present a risk of fire or explosion.
- Dispose of used battery promptly. Keep away from children. Do not disassemble and do not dispose of in fire.

DISPOSAL PRECAUTIONS **CAUTION**

- When disposing of the product, handle it as industrial waste.
- When disposing of batteries, separate them from other wastes according to the local regulations. (Refer to the User's Manual of the GOT to be used for details of the battery directive in the EU member states.)

TRANSPORTATION PRECAUTIONS **CAUTION**

- When transporting lithium batteries, make sure to treat them based on the transport regulations. (Refer to the User's Manual of the GOT to be used for details of the regulated models.)
- Make sure to transport the GOT main unit and/or relevant unit(s) in the manner they will not be exposed to the impact exceeding the impact resistance described in the general specifications of the User's Manual of the GOT to be used, as they are precision devices. Failure to do so may cause the unit to fail. Check if the unit operates correctly after transportation.

Compliance with the Radio Waves Act (South Korea)
This product complies with the Radio Waves Act (South Korea).
Note the following when using the product in South Korea.

이 기기는 업무용 (A급) 전자파적합기기로서 판매자 또는 사용자는 이 점을 주의하시기 바라며, 가정외의 지역에서 사용하는 것을 목적으로 합니다. (The product is for business use (Class A) and meets the electromagnetic compatibility requirements. The seller and the user must note the above point, and use the product in a place except for home.)

Manuals

The following manuals are relevant to this product. When these loose manuals are required, please consult with our local distributor.

Manual name	Contents	Manual Number (Model Code)
GT11 User's Manual (sold separately) *1	Describes the GT11 hardware-relevant content such as part names, external dimensions, mounting, power supply wiring, specifications, and introduction to option devices.	JY997D17501 (09R815)
GOT1000 Series Connection Manual (Mitsubishi Products) for GT Works3 (sold separately) *1	Describes system configurations of the connection method applicable to GOT1000 series and cable creation method	SH-080868ENG (1D7MC2)
GT Designer3 Version1 Screen Design Manual (Fundamentals) 1/2, 2/2 (sold separately) *1	Describes methods of the GT Designer3 installation operation, basic operation for drawing and transmitting data to GOT1000 series	SH-080866ENG (1D7MB9)
GT Designer3 Version1 Screen Design Manual (Functions) 1/2, 2/2 (sold separately) *1	Describes specifications and settings of the object functions used in GT Designer3	SH-080867ENG (1D7MC1)
GOT1000 Series User's Manual (Extended Functions, Option Functions) for GT Works3 (sold separately) *1	Describes extended functions and option functions applicable to GOT series.	SH-080863ENG (1D7MB3)

*1 For relevant manuals, refer to the PDF manuals stored in the CD-ROM for the drawing software used.
For details of a programmable controller to be connected, refer to the programmable controller user's manual respectively.

Bundled Items

Product Name	Model Name	Specifications	
GOT	GT1155-QTBDQ	320 x 240 dots, TFT color LCD (256 colors), built-in battery and backlight, built-in bus interface for connecting to the QCPU (Q mode) and motion controller CPU (Q series), built-in serial interface	
	GT1155-QTBDA	320 x 240 dots, TFT color LCD (256 colors), built-in battery and backlight, built-in bus interface for connecting to the QnACPU, ACP, and motion controller CPU (A series), built-in serial interface	
	GT1155-QSBDQ	320 x 240 dots, STN color LCD (256 colors), built-in battery and backlight, built-in bus interface for connecting to the QCPU (Q mode) and motion controller CPU (Q series), built-in serial interface	
	GT1155-QSBDA	320 x 240 dots, STN color LCD (256 colors), built-in battery and backlight, built-in bus interface for connecting to the QnACPU, ACP, and motion controller CPU (A series), built-in serial interface	
	GT1150-QLBDQ	320 x 240 dots, STN monochrome LCD (black/white, 16 scales), built-in battery and backlight, built-in bus interface for connecting to the QCPU (Q mode) and motion controller CPU (Q series), built-in serial interface	
	GT1150-QLBDA	320 x 240 dots, STN monochrome LCD (black/white, 16 scales), built-in battery and backlight, built-in bus interface for connecting to the QnACPU, ACP, and motion controller CPU (A series), built-in serial interface	
Bundled item	Quantity	Bundled item	Quantity
Mounting brackets	4	GT11 General Description (This manual)	1

1. FEATURES

- Improved monitoring performance and connectivity to FA devices
 - High speed monitoring through high speed communication at maximum of 115.2kbps.
 - Multiple languages are displayed using the Unicode2.1-compatible fonts and beautiful characters are drawn using the TrueType and high quality fonts.
 - High speed display and high speed touch switch response.
- More efficient GOT operations including screen design, startup, adjustment, management and maintenance works
 - The 3MB user memory is included as standard.
 - Font installation is available to increase the system fonts.
- Enhanced support of FA setup tools
 - Transferring or monitoring the sequence programs using the personal computer connected to GOT, during direct connection to Q, QnA or A series programmable controller CPU (FA Transparent function).
 - The USB connector is positioned on the GOT front. This enables the system startup to be performed more efficiently using FA device setup tool, and eliminates the indirect works (opening and closing the control panel, cable replacement, cable rewiring) in order to improve the working efficiency.

2. PART NAME

2.1 Front Panel

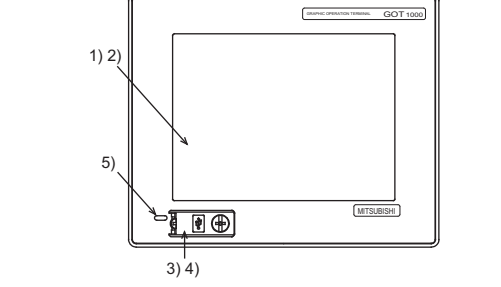

2.2 Back Panel

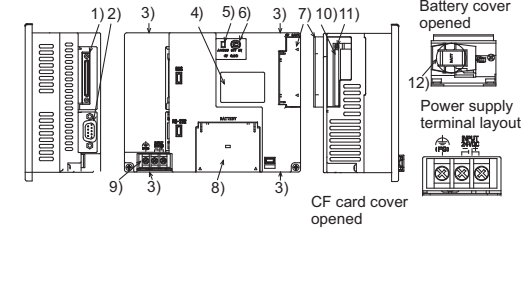

No	Name	Specifications
1)	Display screen	Displays the utility screen and the user creation screen. GT1155-QTBDQ, GT1155-QTBDA ***320 x 240 dots, TFT color liquid crystal GT1155-QSBDQ, GT1155-QSBDA ***320 x 240 dots, STN color liquid crystal GT1150-QLBDQ, GT1150-QLBDA ***320 x 240 dots, STN monochrome (white/black) liquid crystal, 16 scales
2)	Touch key	For operating the touch switches in the utility screen and the user creation screen
3)	USB interface	USB interface for connecting a personal computer (OS installation, project data download, transparent)
4)	USB environmental protection cover	Opens/Closes when the USB interface is used.
5)	POWER LED	Lit in green : Power is correctly supplied Lit in orange : Screen saving Blinking in orange/green : Blown backlight bulb Not lit : Power is not supplied

No	Name	Specifications
1)	BUS interface	For connecting to the QCPU (Q mode) and motion controller CPU (Q series) with the GT1155-QTBDQ, GT1155-QSBDA, and GT1150-QLBDQ
2)	RS-232 interface	For connecting to a controller (bar code reader) or personal computer (OS install, project data download, transparent) (D-sub 9-pin male)
3)	Hole for unit installation fitting	Hole for the inserting installation fittings (accessory) during the GOT installation to the panel (4 holes at top and bottom)
4)	Rating plate (nameplate)	-
5)	CF card access LED	ON: The CF card is accessed. OFF: The CF card is not accessed.
6)	CF card access switch	Switch for disabling the access to the CF card before removing the CF card from the GOT ON : The CF card is accessed. (CF card removal prohibited) OFF : The CF card is not accessed. (CF card removal available)
7)	CF card cover	Open or close when inserting or removing the CF card.
8)	Battery cover	Open or close when replacing the battery.
9)	Power terminal	Power terminal and FG terminal (for power supply (24VDC) to GOT and grounding)
10)	CF card interface	Interface for installing the CF card to GOT
11)	CF card eject button	Button for removing the CF card
12)	Battery	GT11-50BAT battery for storing clock data, alarm history and recipe data (The project data is stored in the built-in flash memory.)

For the personal computer connection, refer to the following.
→ GT Designer3 Version1 Screen Design Manual (Fundamentals) 1/2, 2/2

For the connection to the programmable controller or personal computer, refer to the following.
→ GOT1000 Series Connection Manual (Mitsubishi Products) for GT Works3

3. SPECIFICATIONS

3.1 General Specifications

Item	Specifications	
Operating ambient temperature	Display section 0 to 50°C	
	Other than display section 0 to 55°C (When mounted horizontally), 0 to 50°C (When mounted vertically)	
Storage ambient temperature	-20 to 60°C	
Operating ambient humidity*1	10 to 90% RH, non-condensing	
Storage ambient humidity*1	10 to 90% RH, non-condensing	
Vibration resistance	Conforms to JIS B3502 and IEC61131-2	
	Under intermittent vibration	Frequency: 5 to 9Hz, Acceleration: --, Half-amplitude: 3.5mm
	Under continuous vibration	Frequency: 9 to 150Hz, Acceleration: 9.8m/s ² , Half-amplitude: --
		Frequency: 5 to 9Hz, Acceleration: --, Half-amplitude: 1.75mm
	10 times each in X, Y and Z directions	
Shock resistance	Conforms to JIS B3502, IEC 61131-2 (147 m/s ² , 3 times each in X, Y and Z directions)	
Operating atmosphere	No greasy fumes, corrosive gas, flammable gas, excessive conductive dust, and direct sunlight (Same as storage atmosphere)	
Operating altitude*2	2000 m (6562 ft) max.	
Installation location	Inside control panel	
Overvoltage category*3	II or less	
Pollution degree*4	2 or less	
Cooling method	Self-cooling	

- *1 The wet-bulb temperature is 39°C or less for STN LCDs.
- *2 Do not use or store the GOT under pressure higher than the atmospheric pressure of altitude 0m (0ft.). Failure to observe this instruction may cause a malfunction.
- *3 This indicates the section of the power supply to which the equipment is assumed to be connected between the public electrical power distribution network and the machinery within the premises. Category II applies to equipment for which electrical power is supplied from fixed facilities. The surge voltage withstand level for up to the rated voltage of 300 V is 2500 V.
- *4 This index indicates the degree to which conductive material is generated in the environment where the equipment is used. In pollution degree 2, only non-conductive pollution occurs but temporary conductivity may be produced due to condensation.

3.2 Performance Specifications

Item	Specifications		
	GT1155-QTBDQ GT1155-QTBDA	GT1155-QSBDQ GT1155-QSBDA	GT1150-QLBDQ GT1150-QLBDA
Display section*1	Type	TFT color liquid crystal	STN color liquid crystal
	Screen size	5.7"	STN monochrome (white/black) liquid crystal
	Resolution	320 x 240 dots	
	Display size	W115(4.53) x H86(3.39)[mm](inch)	
	Display character	16-dot standard font: 20 characters x 15 lines, 12-dot standard font: 26 characters x 20 lines (Horizontal format)	
	Display color	256 colors	Monochrome (white/black), 16 scales
	Display angle	Left/Right: 70 degrees, Top: 70 degrees, Bottom: 50 degrees (Horizontal format)	Left/Right: 55 degrees, Top: 65 degrees, Bottom: 70 degrees (Horizontal format)
	Contrast adjustment	-	16-level adjustment
	Intensity of LCD only	400[cd/m ²]	380[cd/m ²]
	Intensity adjustment	8-level adjustment	220[cd/m ²]
Backlight	Life*2	Approx. 50,000h (Operating ambient temperature of 25°C)	
		Cold cathode fluorescent tube (irreplaceable by a user) backlight shutoff detection function is included. Backlight off/screen saving time can be set.	
Touch panel	Life	Approx. 75,000h or longer, Guaranteed: 1 year (Time for display intensity reaches 50% at the operating ambient temperature of 25°C)	Approx. 54,000h or longer, Guaranteed: 1 year (Time for display intensity reaches 50% at the operating ambient temperature of 25°C)
	Number of touch keys	300 keys/screen (Matrix structure of 15 lines x 20 columns)	
	Key size	Minimum 16 x 16 dots (per key)	
	Number of points touched simultaneously	Maximum of 2 points	
Memory	Life	1 million times or more (operating force 0.98N max.)	
	C drive*3	Flash memory (Internal), for storing project data (3Mbytes) and OS	
	Life (Number of write times)	100,000 times	
Battery	D drive	SRAM (Internal), 512kbytes (battery backup)	
	Backup target	GT11-50BAT lithium battery	
Backup output	Life	Clock data, alarm history and recipe data	
		Approx. 5 years (Operating ambient temperature of 25°C), Guaranteed: 1 year	
Environmental protective structure*4	Equivalent to IP67 (JEM1030) (front section) when the USB environmental protective cover is attached		
External dimensions	W167(6.57) x H135(5.32) x D65(2.56)[mm](inch) (Excluding USB environmental protective cover)		
Panel cutting dimensions	W153 (6.03) x H121(4.77)[mm] (inch)		
Weight	0.9kg (Excluding mounting fixtures)		
Compatible software package	GT Designer2 Version2 or later*5		

- *1 Bright dots (always lit) and dark dots (unlit) may appear on a liquid crystal display panel. It is impossible to completely avoid this symptom, as the liquid crystal display comprises of a great number of display elements. Flickers may be observed depending on the display color. Please note that these dots appear due to its characteristic and are not caused by product defect.
- *2 The GOT screen saving/backlight off function prevents images from becoming permanently etched on the display screen and increases the backlight life.
- *3 ROM in which new data can be written without deleting the written data.
- *4 Compliant with IP67 when the USB environmental protection cover is attached. Not compliant when a USB cable is connected. Note that this does not guarantee all users' operation environment.
- *5 For the GT1155-QSBDA, use GT Designer2 Version2 with the version 2.59M or later.

3.3 Built-in Interface Specifications

Item	Specifications	
	GT1155-QTBDQ GT1155-QSBDQ GT1150-QLBDQ	GT1155-QTBDA GT1155-QSBD A GT1150-QLBDA
BUS	Bus interface for connecting to the QCPU (Q mode) and motion controller CPU (Q series) 1ch Application : For communicating with a programmable controller	Bus interface for connecting to the QnACPU, ACPU, and motion controller CPU (A series) 1ch Application : For communicating with a programmable controller
Built-in interface	RS-232	Conforming to serial RS232 standard, 1ch Transmission speed: 115,200/57,600/38,400/19,200/9,600/4,800bps Connector shape : D-sub 9-pin (Male) Application : Bar code reader connection, Personal computer communication (Project data upload/download, OS installation, transparent function)
	USB	Conforming to serial USB (Full Speed 12Mbps), device, 1ch Application: Personal computer communication (Project data upload/download, OS installation, transparent function)
	CF card	Conforming to PCMCIA, compact flash slot, 1ch Connector shape : Dedicated for TYPE I Application : Data transfer, data storage

3.4 Power Supply Specifications

Item	Specifications		
	GT1155-QTBDQ GT1155-QTBDA	GT1155-QSBDQ GT1155-QSBD A	GT1150-QLBDQ GT1150-QLBDA
Input power supply voltage	24VDC (+10% -15%), ripple voltage 200mV or less		
Fuse (built-in, not exchangeable)	1.0A		
Power consumption	11.16W (465mA/24VDC) or less	9.72W (405mA/24VDC) or less	7.92W (330mA/24VDC) or less
At backlight off	5.04W (210mA/24VDC) or less		
Inrush current	26A or less (26.4V) 4ms		
Permissible instantaneous power failure time ¹	Within 10ms		
Noise immunity	Noise voltage: 500Vp-p, Noise width: 1μs (by noise simulator of 25to 60Hz noise frequency)		
Dielectric withstand voltage ²	500VAC for 1 minute (across power supply terminals and earth)		
Insulation resistance ²	10MΩ or larger by a 500VDC insulation resistance tester (across power supply terminals and earth)		
Applicable wire size	0.75 to 2[mm ²]		
Applicable solderless terminal	Solderless terminal for M3 screw RAV1.25-3, V2-N3A, FV2-N3A		
Applicable tightening torque (Terminal block terminal screw)	0.5 to 0.8[N·m]		

- *1 The GOT continues to operate even upon 5ms or shorter instantaneous power failure. The GOT stops operating if there is extended power failure or voltage drop, while it automatically resumes operation as soon as the power is restored.
- *2 A surge absorber is connected between the power supply and earth terminal so that the GOT does not malfunction due to applied lightning surge noise. Values without a surge absorber are described for the dielectric withstand voltage and the insulation resistance.

3.5 External Dimensions

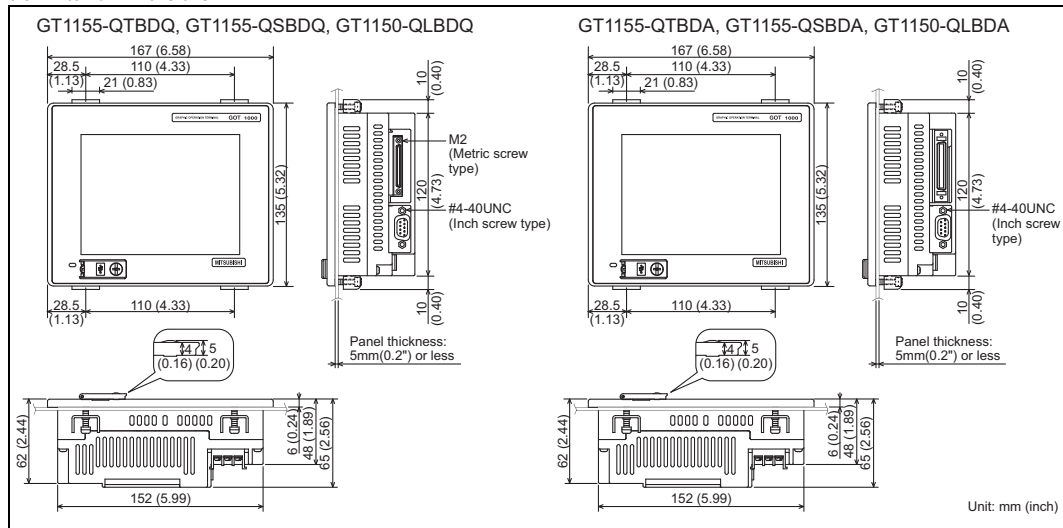

4. EMC AND LOW VOLTAGE DIRECTIVE

For the products sold in European countries, the conformance to the EMC Directive, which is one of the European Directives, has been a legal obligation since 1996. Also, conformance to the Low Voltage Directive, another European Directives, has been a legal obligation since 1997.

Manufacturers who recognize their products must conform to the EMC and Low Voltage Directive are required to declare that their products conform to these Directives and put a "CE mark" on their products.

- Authorized representative in Europe

Authorized representative in Europe is shown below

Name : Mitsubishi Electric Europe BV

Address: Gothaer strasse 8, 40880 Ratingen, Germany

4.1 Requirements for Conformance to EMC Directive

The EMC Directive specifies that products placed on the market must "be so constructed that they do not cause excessive electromagnetic interference (emissions) and are not unduly affected by electromagnetic interference (immunity)". The applicable products are requested to meet these requirements.

The sections 4.1.1 through 4.1.3 summarize the precautions on conformance to the EMC Directive of the machinery constructed using the GOT. The details of these precautions has been prepared based on the requirements and the applicable standards control.

However, we will not assure that the overall machinery manufactured according to these details conforms to the above-mentioned directives.

The method of conformance to the EMC Directive and the judgment on whether or not the machinery conforms to the EMC Directive must be determined finally by the manufacturer of the machinery.

4.1.1 Standards applicable to the EMC Directive

The following products have shown compliance through direct testing (to the identified standards) and design analysis (forming a technical construction file) to the European Directive for Electromagnetic Compatibility (89/336/EEC) when used as directed by the appropriate documentation

Type : Programmable Controller (Open Type Equipment)

Models : MELSEC GOT series products, identified here, manufactured from

January 7th, 2008

GT1155-QTBDQ, GT1155-QTBDA, GT1155-QSBDQ, GT1155-QSBD A,

GT1150-QLBDQ, GT1150-QLBDA (For this product see note under and over the page).

Standard	Remark	
EN61131-2 : 2007 Programmable controllers - Equipment, requirement and tests	EMI	Compliance with all relevant aspects of the standard. (Radiated Emissions)
	EMS	Compliance with all relevant aspects of the standard. (ESD, RF electromagnetic field, EFTB, Surge, RF conducted disturbances and Power frequency magnetic field)

4.1.2 Control cabinet

The GOT is an open type device (device installed to another device) and must be installed in a conductive control panel or cabinet.

It not only assure the safety but also has a large effect to shut down the noise generated from GOT, on the control panel.

1) Control cabinet

- Use a conductive control cabinet.
- When attaching the control cabinet's top plate or base plate, mask painting and weld so that good surface contact can be made between the cabinet and plate.
- To ensure good electrical contact with the control cabinet, mask the paint on the installation bolts of the inner plate in the control cabinet so that contact between surfaces can be ensured over the widest possible area.
- Earth the control cabinet with a thick wire so that a low impedance connection to ground can be ensured even at high frequencies. (22mm 2 wire or thicker is recommended.)
- Holes made in the control cabinet must be 10 cm (3.94") diameter or less. If the holes are 10cm (3.94") or larger, radio frequency noise may be emitted. In addition, because radio waves leak through a clearance between the control panel door and the main unit, reduce the clearance as much as practicable. The leakage of radio waves can be suppressed by the direct application of an EMI gasket on the paint surface.

2) Connection of power and ground wires

Ground and power supply wires for the GOT must be connected as described below.

- Provide an earthing point near the GOT. Earth the power supply's FG terminal (FG: Frame Ground) with the thickest and shortest wire possible. (The wire length must be 30cm (11.18") or shorter.) The FG terminal function is to pass the noise generated in the GOT to the ground, so an impedance that is as low as possible must be ensured. As the wires are used to relieve the noise, the wire itself carries a large noise content and thus short wiring means that the wire is prevented from acting as an antenna. Note) A long conductor will become a more efficient antenna at high frequency.

3) Electrical shock prevention

In order to such as the operators from electric shocks, the control box must have the following functions :

- The control cabinet must be equipped with a lock so that only skilled or qualified personnel.
- The control cabinet must be fitted with advice which automatically stops the power supply when the cabinet is opened.

4) Dustproof and waterproof features

The control box also has the dustproof and waterproof functions. Insufficient dustproof and waterproof features lower the insulation withstand voltage, resulting in insulation destruction. The insulation in our GOT is designed to cope with the pollution level 2, so use in an environment with pollution level 2 or better.

Pollution level 1: An environment where the air is dry and conductive dust does not exist.

Pollution level 2: An environment where conductive dust does not usually exist, but occasional temporary conductivity occurs due to the accumulated dust. Generally, this is the level for inside the control box equivalent a control room or on the floor of a typical factory.

Pollution level 3: An environment where conductive dust exists and conductivity may be generated due to the accumulated dust. An environment for a typical factory floor.

Pollution level 4: Continuous conductivity may occur due to rain, snow, etc. An outdoor environment.

4.1.3 Grounding

It is necessary to use the GOT grounding terminal only when it is in the grounded condition.

Be sure to ground the grounding for the safety reasons and EMC Directives.

Functional grounding : Improves the noise resistance.

4.2 Wiring Precautions the Part which Matches the EMC Directives

Connect and wire GOT equipment as instructed below. If the GOT equipment is configured in a way that differs from the following instructions then the system will not comply with EMC directives.

4.2.1 About the cable used

Connect and wire GOT equipment as instructed below. If the GOT equipment is configured in a way that differs from the following instructions then the system will not comply with EMC directives.

Bus connection cable
The following products are used in the EMC specification compatibility test conducted by Mitsubishi Electric Corporation.

- ZCAT3035-1330 ferrite core manufactured by TDK corporation
- AD75CK-type cable clamp manufactured by MITSUBISHI
- Zipper tube SHNJ type manufactured by Zippertubing(Japan),Ltd.

GOT Unit	Existing Cables	User Made Cables
GT1155-QTBDQ, GT1155-QSBDQ, GT1150-QLBDQ	GT15-QC□B, GT15-QC□BS modified as shown in EX.1 Peel the sheath at both ends of the cable, and expose the shield braided wire for grounding. (For grounding with clamps, refer to Section 4.2.3.)	The cable need to be independently tested by the user to demonstrate EMC compatibility when they are used with the GOT, the PLC of MELSEC-Q series, MELSEC-QnA series, and MELSEC-A series.
GT1155-QTBDA, GT1155-QSBD A, GT1150-QLBDA	GT15-C□BS, cGT15-C□EXSS-S1 modified as shown in EX.2 Peel the sheath at both ends of the cable, and expose the shield braided wire for grounding. (For grounding with clamps, refer to Section 4.2.3.) Other bus connection cables modified as shown in EX.3. Wind cable shield material around the cable, and pull out the grounding braided wire of the cable shield material. Attach the ferrite core to the cable in the specified position and insert the braided wire for grounding into the ferrite core.	

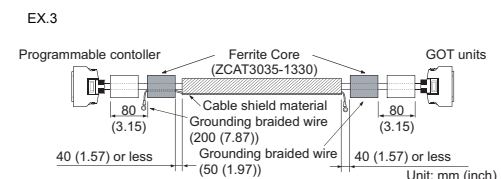
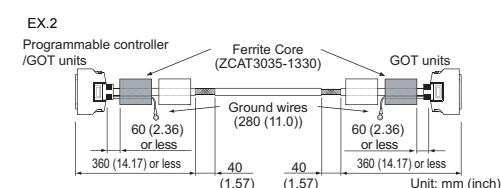

4.2.2 Method to connect the power wire and ground wire

- GT1155-QTBDQ, GT1155-QTBDA, GT1155-QSBDQ, GT1155-QSBD A, GT1150-QLBDQ, GT1150-QLBDA
Twist the 24VDC cables to connect to the GT1155-QTBDQ, GT1155-QTBDA, GT1155-QSBDQ, GT1155-QSBD A, GT1150-QLBDQ, and GT1150-QLBDA. The ferrite filter is not required for the 24VDC cables. the GT1155-QTBDQ, GT1155-QTBDA, GT1155-QSBDQ, GT1155-QSBD A, GT1150-QLBDQ, and GT1150-QLBDA unit requires an additional ferrite filter to be attached to the 24V DC power supply cables. The filter should be attached in a similar manner as shown in the figure opposite, i.e. the power cables are wrapped around the filter. However, as with all EMC situations the more correctly applied precautions the better the systems Electro-magnetic Compatibility. The ferrite recommended is a TDK ZCAT3035-1330 or similar. The ferrite should be placed as near to the 24V DC terminals of the the GT1155-QTBDQ, GT1155-QTBDA, GT1155-QSBDQ, GT1155-QSBD A, GT1150-QLBDQ, and GT1150-QLBDA as possible (which should be within 75mm of the GOT terminal).

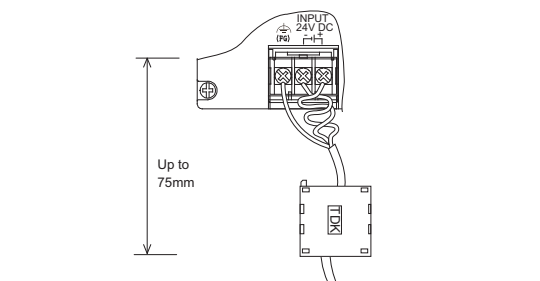

4.2.3 Grounding the cable

Use the bus connection cable to ground the cable and grounding wire to the control panel where the GOT and base unit are installed.

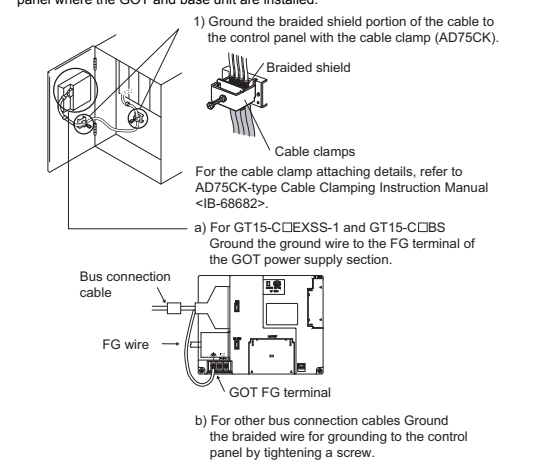

5. INSTALLATION

5.1 Control Panel Inside Dimensions for Mounting GOT

Mount the GOT onto the control panel while considering the following control panel inside dimensions.

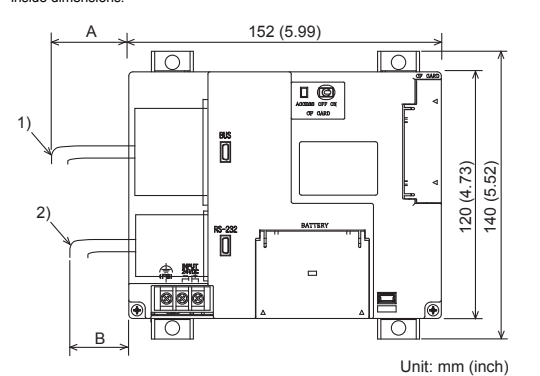

Model Name	A	B
GT1155-QTBDQ GT1155-QSBDQ GT1150-QLBDQ	56 (2.20)	40 (1.57)
GT1155-QTBDA GT1155-QSBD A GT1150-QLBDA	38 (1.50)	40 (1.57)

No	Name
1)	Bus connection cable
2)	Personal computer connection cable/bar code reader connection cable

Applicable cable

Some cables may need to be longer than the specified dimensions when connecting to the GOT. Therefore, consider the connector dimensions and bending radius of the cable as well for installation.

5.2 Panel Cutting Dimensions

Make holes in the panel according to the dimensions list below. Also, ensure 10mm spaces in upper and lower parts of the panel for mounting fixtures.

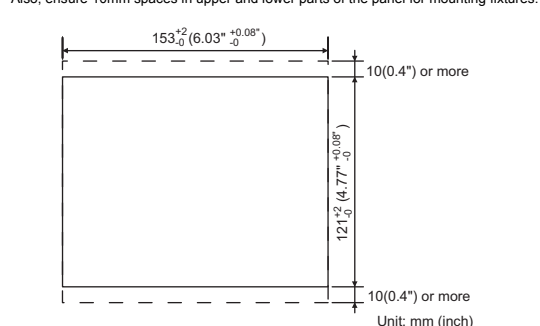

5.3 Mounting Position

When mounting the GOT, the clearances shown on the right must be left from a structure or the other device.
Secure 50mm (1.97") or more on the left, right and bottom sides of the GOT to structures or other devices.
Secure 80mm (3.15") or more on the top of the GOT from structures or other devices to allow good ventilation.
If devices (such as a contactor) generating radiated noise or those generating heat are arranged around the GOT, secure 100mm (3.94") or more on the back panel.
When using the CF card, secure a sufficient distance on the left side to allow installation and removal of the CF card. [Securing 100mm (3.94") or more is recommended.]

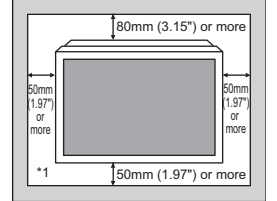

*1 To use the CF card, leave sufficient distances for removal and installation of the CF card.

5.4 Control Panel Inside Temperature and Mounting Angle

When mounting the main unit to a control panel or similar, set the display section as shown below.

When the temperature inside the control panel is 40 to 55°C (Horizontal mount), 40 to 50°C (Vertical mount), the mounting angle should be in the range 60° to 105° degrees.

- The GOT will be deteriorated earlier if it is used at the mounting angle other than the above. Therefore, the temperature inside the control panel should be within 40°C.

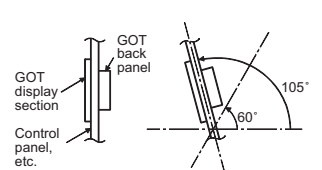

5.5 Installation Procedure

The GOT is designed to be embedded into a panel. Mount the GOT by following the procedure below. For panel cutting dimensions, refer to Section 4.2. Note that the panel thickness should be within 5mm.

- Inserting into the panel face
Insert the GOT from the front side of the panel.
- Fixing the GOT
Engage the hook of the mounting fitting (accessory) to the unit fixing hole of the GOT and tighten the screw until the GOT is fixed with the mounting bolt (accessory). The GOT will be fixed in 4 upper/lower parts.
Tighten the mounting screw with the specified torque. (Failure to do so may distort the panel and make a surface waviness on the protective sheet.)
- A protection film is attached on the display section of GOT prior to shipment. Remove the film when the installation is completed.

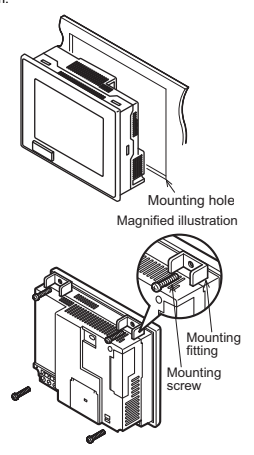

IB-0800385ENG-F-2/2

6. WIRING

6.1 Power Supply Wiring

Connect the power terminal on the GOT rear face with the 24VDC terminal of the external power.
Use 0.75mm² or more cables so as not to produce voltage drops.
Use solderless terminals for M3 screws, and be sure to tighten the screws with a tightening torque of 0.5 to 0.8N·m.

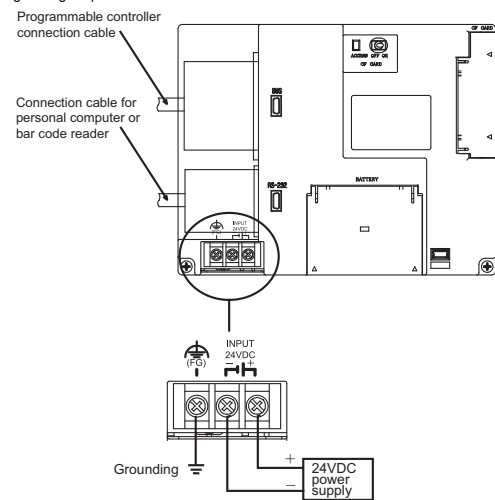

- The independent grounding is basically required.
Ground the GOT with a ground resistance of 100Ω or less.
- If the independent grounding is impossible, carry out the shared grounding as shown in fig.2 below.
- Use the cable of 2mm² or more for grounding.
Set the grounding point closer to the GOT to make the grounding cable short as possible.

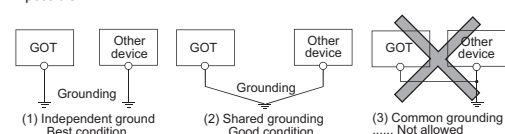

1) Recommended terminal shape

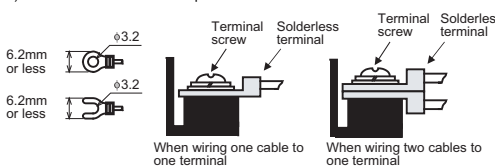

Applicable solderless terminal	RAV 1.25-3, V2-N3A and FV2-N3A
--------------------------------	--------------------------------

7.3 Battery Replacement

The battery backs up clock data, alarm history and recipe data.
Screen data is stored in the flash memory and data is retained even if the battery is dead.

- Battery model name
GT11□□ is shipped with the following battery.

Product name	Model name
Battery	GT11-50BAT

7. MAINTENANCE AND INSPECTION

The GOT does not include consumable components that will cause the shorten life. However, note that battery life is 5 years and LCD life is 50,000 hours. The life of backlight in GT1155-QTBDO, GT1155-QTBDA, GT1155-QSBDQ, GT1155-QSBDA is 75,000 hours and that in GT1150-QLBDO, GT1150-QLBDA is 54,000 hours. It is recommended to replace the battery periodically. (For the replacement of the liquid crystal screen and backlight, please consult your nearest sales office or FA Center.)

7.1 Daily Inspection

No.	Inspection Item	Inspection Method	Criterion	Action	
1	GOT mounting status	Check for loose mounting screws.	Securely mounted	Retighten screws within the specified torque range	
2	Connection status	Loose terminal screws	Retighten screws with screwdriver	Not loose	Retighten terminal screws
		Proximate solderless terminals	Visual check	Proper intervals	Correct
	Loose connectors	Visual check	Not loose	Retighten connector fixing screws	
3	Usage status	Dirt on protection sheet	Visual check	Not outstanding	Replace with new one
	Foreign material attachment	Visual check	No foreign matter sticking	Remove clean	

Refer to the following for the model names of the protection sheet or the replacement procedure.

→ GT11 User's Manual

7.2 Periodic Inspection

Yearly or half-yearly inspection items

The following inspection should also be performed when equipment has been moved or modified or the wiring changed.

No.	Inspection Item	Inspection Method	Criterion	Action	
1	Surrounding environment	Ambient temperature	Make measurement with thermometer or hygrometer	Display section 0 to 50°C Other portions 0 to 55°C	For use in control panel, temperature inside control panel is ambient temperature
		Ambient humidity	Measure corrosive gas	10 to 90%RH	
		Atmosphere	No corrosive gas		
2	Power supply voltage check	24VDC Measure voltage across terminals.	20.4 to 26.4VDC	Change supply power	
3	Connection status	Loose terminal screws	Retighten screws with screwdriver	Not loose	Retighten terminal screws
		Proximate solderless terminals	Visual check	Proper intervals	Correct
		Loose connectors	Visual check	Not loose	Retighten connector fixing screws

- Battery replacement procedure
 - Turn the GOT power off.
 - Open the back cover of the GOT.
 - Remove the old battery from the holder.
 - Disconnect the old battery connector and insert the new battery connector within 30s. (Clock data, alarm history, and recipe data is retained by the GOT condenser for 30 seconds.)
 - Insert the new battery into the holder and close the back cover.

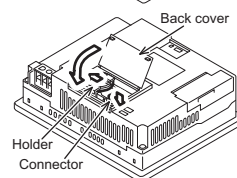
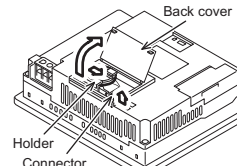

- How to confirm production year and month

The production year and month of the battery built in the purchased GOT can be confirmed by the production No. (serial No.) marked on the GOT main unit.

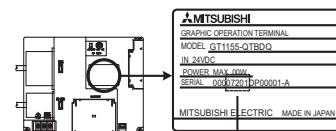

Year (example: 2007) last digit: 0 7 2 0 1
Day (example: 1st) 1 to 31: 1st to 31st
Month (example: Jun.) 1 to 9: Jan. to Sep., X: Oct., Y: Nov., Z: Dec.

- Battery life
Approximate battery life:
5 years (ambient temperature: 25°C) [Guaranteed for 1 year]
Battery replacement: In 4 to 5 years

Approximate life is 5 years, but life may be shorter depending on the ambient temperature, therefore, note that the battery must be replaced in 4 to 5 years. Make sure to purchase a new battery as needed as it self-discharges.

Battery status can be confirmed on a GOT utility screen.
For details of battery status or how to output alarm, refer to the following:
→ GT11 User's Manual

Warranty

Mitsubishi will not be held liable for damage caused by factors found not to be the cause of Mitsubishi; machine damage or lost profits caused by faults in the Mitsubishi products; damage, secondary damage, accident compensation caused by special factors unpredictable by Mitsubishi; damages to products other than Mitsubishi products; and to other duties.

For safe use

- This product has been manufactured as a general-purpose part for general industries, and has not been designed or manufactured to be incorporated in a device or system used in purposes related to human life.
- Before using the product for special purposes such as nuclear power, electric power, aerospace, medicine or passenger movement vehicles, consult with Mitsubishi.
- This product has been manufactured under strict quality control. However, when installing the product where major accidents or losses could occur if the product fails, install appropriate backup or failsafe functions in the system.

Country/Region	Sales office/Tel
U.S.A	Mitsubishi Electric Automation Inc. 500 Corporate Woods Parkway Vernon Hills, IL 60061, U.S.A. Tel : +1-847-478-2100
Brazil	MELCO-TEC Rep. Com.e Assessoria Tecnica Ltda. Rua Correia Dias, 184, Edificio Paraiso Trade Center-8 andar Paraiso, Sao Paulo, SP Brazil Tel : +55-11-5908-8331
Germany	Mitsubishi Electric Europe B.V. German Branch Gothaer Strasse 8 D-40880 Ratingen, GERMANY Tel : +49-2102-486-0
U.K	Mitsubishi Electric Europe B.V. UK Branch Travellers Lane, Hatfield, Hertfordshire., AL10 8XB, U.K. Tel : +44-1707-276100
Italy	Mitsubishi Electric Europe B.V. Italian Branch Centro Dir. Colleoni, Pal. Perseo-Ingr.2 Via Paracelso 12, I-20041 Agrate Brianza., Milano, Italy Tel : +39-039-60531
Spain	Mitsubishi Electric Europe B.V. Spanish Branch Carretera de Rubi 76-80 E-08190 Sant Cugat del Valles, Barcelona, Spain Tel : +34-93-565-3131
France	Mitsubishi Electric Europe B.V. French Branch 25, Boulevard des Bouvets, F-92741 Nanterre Cedex, France TEL : +33-1-5569-5569
South Africa	Circuit Breaker Industries Ltd. Private Bag 2016, ZA-1600 Isando, South Africa Tel : +27-11-928-2000
Hong Kong	Mitsubishi Electric Automation (Hong Kong) Ltd. 10th Floor, Manulife Tower, 169 Electric Road, North Point, Hong Kong Tel : +852-2887-8870
China	Mitsubishi Electric Automation (China) Ltd. 4F, Zhi Fu Plaza, No.80 Xin Chang Road, Shanghai 200003, China Tel : +86-21-6120-0808
Taiwan	Setsuyo Enterprise Co., Ltd. 6F No.105 Wu-Kung 3rd.Rd, Wu-Ku Hsiang, Taipei Hsiang, Taiwan Tel : +886-2-2299-2499
Korea	Mitsubishi Electric Automation Korea Co., Ltd. 1480-6, Gayang-dong, Gangseo-ku Seoul 157-200, Korea Tel : +82-2-3660-9552
Singapore	Mitsubishi Electric Asia Pte. Ltd. 307 Alexandra Road #05-01/02, Mitsubishi Electric Building, Singapore 159943 Tel : +65-6470-2460
Thailand	Mitsubishi Electric Automation (Thailand) Co., Ltd. Bang-Chan Industrial Estate No.111 Moo 4, Serithai Rd, T.Kannayao, A.Kannayao, Bangkok 10230 Thailand Tel : +65-2-517-1326
Indonesia	P.T. Autoteknindo Sumber Makmur Muara Karang Selatan, Block A/Utara No.1 Kav. No.11 Kawasan Industri Pergudangan Jakarta - Utara 14440, P.O.Box 5045 Jakarta, 11050 Indonesia Tel : +62-21-8630833
India	Messung Systems Pvt. Ltd. Electronic Sadan NO.III Unit No15, M.I.D.C.Bhosari, Pune-411026, India Tel : +91-20-2712-3130
Australia	Mitsubishi Electric Australia Pty. Ltd. 348 Victoria Road, Rydalmere, N.S.W 2116, Australia Tel : +61-2-9684-7777

MITSUBISHI ELECTRIC CORPORATION
HEAD OFFICE : TOKYO BUILDING, 2-7-3 MARUNOUCHI, CHYODAKU, TOKYO 100-8310, JAPAN
NAGOYA WORKS : 1-14, YADA-MINAMI 5-CHOME, HIGASHI-KU, NAGOYA, JAPAN

When exported from Japan, this manual does not require application to the Ministry of Economy, Trade and Industry for service transaction permission.

Specifications subject to change without notice.
Printed in Japan, May 2011.