

Programmable Controller

MELSEC **Q** series

Q Corresponding MELSECNET/H Network System Reference Manual (Remote I/O network)

- QJ71LP21
- QJ71LP21-25
- QJ71LP21S-25
- QJ71LP21G
- QJ71LP21GE
- QJ71BR11
- QJ72LP25-25
- QJ72LP25G
- QJ72LP25GE
- QJ72BR15

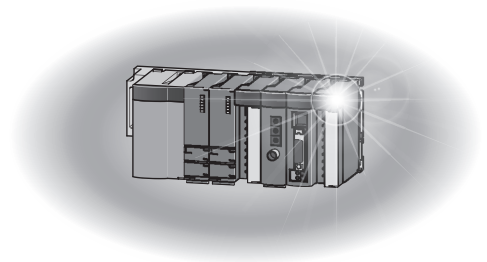

● SAFETY PRECAUTIONS ●

(Read these precautions before using this product.)

Before using this product, please read this manual and the relevant manuals carefully and pay full attention to safety to handle the product correctly.

The precautions given in this manual are concerned with this product only. For the safety precautions of the programmable controller system, refer to the user's manual for the CPU module used.

In this manual, the safety precautions are classified into two levels: "⚠ WARNING" and "⚠ CAUTION".



Indicates that incorrect handling may cause hazardous conditions, resulting in death or severe injury.



Indicates that incorrect handling may cause hazardous conditions, resulting in minor or moderate injury or property damage.

Under some circumstances, failure to observe the precautions given under "⚠ CAUTION" may lead to serious consequences.

Observe the precautions of both levels because they are important for personal and system safety. Make sure that the end users read this manual and then keep the manual in a safe place for future reference.

[Design Precautions]

WARNING

- When the network develops a communication error, the station with the communication error will enter into the following status.
Check the communication status information and configure an interlock circuit in the sequence program to ensure that the entire system will operate safely. Failure to do so may result in an accident due to an incorrect output or malfunction.
 - (1) The remote master station will hold the data from before the communication error.
 - (2) The remote I/O station turns off all outputs. The output module of the remote I/O station can clear/hold the output status at the time of error by using the remote I/O module parameters. As the parameters are set to "clear" by default, the output module turns off the outputs at the time of error. If it is required to hold the output in order to operate the system safely, set the parameters to "hold".

[Design Precautions]

WARNING

- When connecting a peripheral with the programmable controller CPU or connecting a personal computer with an intelligent function module to modify data of a running programmable controller, configure an interlock circuit in the sequence program to ensure that the entire system will always operate safely. For other forms of control (such as program modification or operating status change) of a running programmable controller, read the relevant manuals carefully and ensure that the operation is safe before proceeding. Especially, when a remote programmable controller is controlled by an external device, immediate action cannot be taken if a problem occurs in the programmable controller due to a communication failure. To prevent this, configure an interlock circuit in the sequence program, and determine corrective actions to be taken between the external device and CPU module in case of a communication failure.
- If a communication cable is disconnected, the network may be unstable, resulting in a communication failure of multiple stations. Configure an interlock circuit in the program to ensure that the entire system will always operate safely even if communications fail. Failure to do so may result in an accident due to an incorrect output or malfunction.

CAUTION

- Do not install the control lines or communication cables together with the main circuit lines or power cables. Keep a distance of 100mm or more between them. Failure to do so may result in malfunction due to noise.
- Reset the CPU module or remote I/O module after changing its parameters. Failure to do so may cause malfunction because the previous parameter settings remain in the module.

[Security Precautions]

WARNING

- To maintain the security (confidentiality, integrity, and availability) of the programmable controller and the system against unauthorized access, denial-of-service (DoS) attacks, computer viruses, and other cyberattacks from external devices via the network, take appropriate measures such as firewalls, virtual private networks (VPNs), and antivirus solutions.

[Installation Precautions]

CAUTION

- Use the programmable controller in an environment that meets the general specifications in the user's manual for the CPU module used. Failure to do so may result in electric shock, fire, malfunction, or damage to or deterioration of the product.
- To mount the module, while pressing the module mounting lever located in the lower part of the module, fully insert the module fixing projection(s) into the hole(s) in the base unit and press the module until it snaps into place. Incorrect mounting may cause malfunction, failure or drop of the module. When using the programmable controller in an environment of frequent vibrations, fix the module with a screw.

[Installation Precautions]

CAUTION

- Tighten the screws within the specified torque range. Undertightening can cause drop of the screw, short circuit, or malfunction. Overtightening can damage the screw and/or module, resulting in drop, short circuit, or malfunction
- Shut off the external power supply (all phases) used in the system before mounting/removing a module or connecting/disconnecting a connector. Failure to do so may result in damage to the product. Modules can be replaced online on a remote I/O station where a remote I/O module with function version D or later is used. Note that there are restrictions on the modules that can be replaced online, and each module has its predetermined replacement procedure. For details, refer to the relevant section in this manual.
- Do not directly touch any conductive parts and electronic components of the module. Doing so can cause malfunction or failure of the module.

[Wiring Precautions]

WARNING

- Shut off the external power supply (all phases) used in the system before installation and wiring. Failure to do so may result in electric shock or damage to the product.

[Wiring Precautions]

CAUTION

- Individually ground the FG terminal of the programmable controller with a ground resistance of 100Ω or less.
Failure to do so may result in electric shock or malfunction.
- Check the rated voltage and terminal layout before wiring to the module, and connect the cables correctly. Connecting a power supply with a different voltage rating or incorrect wiring may cause a fire or failure.
- Connectors for external devices and coaxial cables must be crimped or pressed with the tool specified by the manufacturer, or must be correctly soldered. Incomplete connections may cause short circuit, fire, or malfunction.
- Place the cables in a duct or clamp them. If not, dangling cable may swing or inadvertently be pulled, resulting in damage to the module or cables or malfunction due to poor contact.
- Tighten the terminal screws within the specified torque range. Undertightening can cause short circuit, fire, or malfunction. Overtightening can damage the screw and/or module, resulting in drop, short circuit, or malfunction.
- When disconnecting the cable from the module, do not pull the cable by the cable part. For the cable with connector, hold the connector part of the cable. For the cable connected to the terminal block, loosen the terminal screw. Pulling the cable connected to the module may result in malfunction or damage to the module or cable.
- Prevent foreign matter such as dust or wire chips from entering the module. Such foreign matter can cause a fire, failure, or malfunction.
- When a protective film is attached to the top of the module, remove it before system operation. If not, inadequate heat dissipation of the module may cause a fire, failure, or malfunction.
- Mitsubishi Electric programmable controllers must be installed in control panels. Connect the main power supply to the power supply module in the control panel through a relay terminal block. Wiring and replacement of a power supply module must be performed by qualified maintenance personnel with knowledge of protection against electric shock. For wiring methods, refer to the QCPU User's Manual (Hardware Design, Maintenance and Inspection).

[Setup and Maintenance Precautions]

WARNING

- Do not touch any terminal while power is on. Doing so will cause electric shock or malfunction.
- Shut off the external power supply (all phases) used in the system before cleaning the module or retightening the terminal screws or module fixing screws.
Failure to do so may result in electric shock or cause the module to fail or malfunction.

[Setup and Maintenance Precautions]

CAUTION

- Before performing online operations (especially, program modification, forced output, and operating status change) for the running CPU module on another station from GX Developer over the MELSECNET/H network, read relevant manuals carefully and ensure the safety. Improper operation may damage machines or cause accidents.
- Do not disassemble or modify the modules.
Doing so may cause failure, malfunction, injury, or a fire.
- Use any radio communication device such as a cellular phone or PHS (Personal Handy-phone System) 25cm or more away in all directions from the programmable controller.
Failure to do so may cause malfunction.
- Shut off the external power supply (all phases) used in the system before mounting/removing a module or connecting/disconnecting a connector. Failure to do so may cause the module to fail or malfunction. Modules can be replaced online in a remote I/O network system where a remote I/O module with function version D or later is used. Note that there are restrictions on the modules that can be replaced online, and each module has its predetermined replacement procedure. For details, refer to the relevant section in this manual.
- After the first use of the product, do not mount/remove the module to/from the base unit more than 50 times (IEC 61131-2 compliant).
Exceeding the limit of 50 times may cause malfunction.
- Before handling the module, touch a conducting object such as a grounded metal to discharge the static electricity from the human body.
Failure to do so may cause the module to fail or malfunction.

[Disposal Precautions]

CAUTION

- When disposing of this product, treat it as industrial waste.

• CONDITIONS OF USE FOR THE PRODUCT •

(1) MELSEC programmable controller ("the PRODUCT") shall be used in conditions;

i) where any problem, fault or failure occurring in the PRODUCT, if any, shall not lead to any major or serious accident;
and

ii) where the backup and fail-safe function are systematically or automatically provided outside of the PRODUCT for the case of any problem, fault or failure occurring in the PRODUCT.

(2) The PRODUCT has been designed and manufactured for the purpose of being used in general industries.

MITSUBISHI ELECTRIC SHALL HAVE NO RESPONSIBILITY OR LIABILITY (INCLUDING, BUT NOT LIMITED TO ANY AND ALL RESPONSIBILITY OR LIABILITY BASED ON CONTRACT, WARRANTY, TORT, PRODUCT LIABILITY) FOR ANY INJURY OR DEATH TO PERSONS OR LOSS OR DAMAGE TO PROPERTY CAUSED BY the PRODUCT THAT ARE OPERATED OR USED IN APPLICATION NOT INTENDED OR EXCLUDED BY INSTRUCTIONS, PRECAUTIONS, OR WARNING CONTAINED IN MITSUBISHI ELECTRIC USER'S, INSTRUCTION AND/OR SAFETY MANUALS, TECHNICAL BULLETINS AND GUIDELINES FOR the PRODUCT.

("Prohibited Application")

Prohibited Applications include, but not limited to, the use of the PRODUCT in;

- Nuclear Power Plants and any other power plants operated by Power companies, and/or any other cases in which the public could be affected if any problem or fault occurs in the PRODUCT.
- Railway companies or Public service purposes, and/or any other cases in which establishment of a special quality assurance system is required by the Purchaser or End User.
- Aircraft or Aerospace, Medical applications, Train equipment, transport equipment such as Elevator and Escalator, Incineration and Fuel devices, Vehicles, Manned transportation, Equipment for Recreation and Amusement, and Safety devices, handling of Nuclear or Hazardous Materials or Chemicals, Mining and Drilling, and/or other applications where there is a significant risk of injury to the public or property.

Notwithstanding the above restrictions, Mitsubishi Electric may in its sole discretion, authorize use of the PRODUCT in one or more of the Prohibited Applications, provided that the usage of the PRODUCT is limited only for the specific applications agreed to by Mitsubishi Electric and provided further that no special quality assurance or fail-safe, redundant or other safety features which exceed the general specifications of the PRODUCTS are required. For details, please contact the Mitsubishi Electric representative in your region.

(3) Mitsubishi Electric shall have no responsibility or liability for any problems involving programmable controller trouble and system trouble caused by DoS attacks, unauthorized access, computer viruses, and other cyberattacks.

REVISIONS

* The manual number is given on the bottom left of the back cover.

Print Date	* Manual Number	Revision
Oct., 2000	SH (NA) -080124-A	First printing
May., 2001	SH (NA) -080124-B	<p>Model addition</p> <p>QJ71LP21G, QJ72LP25G, QJ71LP21GE, QJ72LP25GE</p> <p>Correction</p> <p>Product Components, About The Generic Terms And Abbreviations, Chapter 1, Section 1.2, 2.4, 3.1.1, 3.1.2, 3.2.1, 3.2.2, 3.3.2, 4.2.1, 4.2.2, 4.8.2, Chapter 5, Section 5.1.5, 5.2.1, 6.1.2, 6.2.1, 6.3, 6.4, 7.1.1, 7.8, 8.1, 8.1.1, 8.1.4, 8.3.1, 8.3.2, Appendix 2, 3, 4, 5, Index</p> <p>Addition</p> <p>Section 8.2.6</p>
Apr., 2002	SH (NA) -080124-C	<p>Correction</p> <p>Section 1.2, 1.3, 2.3.1, 2.3.2, 2.3.3, 2.5, 3.1.1, 3.1.2, 3.2, 3.3.2, 4.2.1, 6.1.1, 6.4, Chapter 7, Section 8.4, Appendix 2, 3</p> <p>Changed item numbers</p> <p>Section 2.3 → Section 2.4, Section 2.4 → Section 2.5</p> <p>Addition</p> <p>Section 7.10</p>
Nov., 2002	SH (NA) -080124-D	<p>Model addition</p> <p>QJ71LP21S-25</p> <p>Correction</p> <p>SAFETY PRECAUTIONS, CONTENTS, Generic Terms And Abbreviations, Product Components, Section 1.1, 1.2, 3.1.1, 3.1.2, 4.1.2, 4.8.1, 4.8.2, 7.1.1, 8.1.4, Appendix 2, 3</p>
Apr., 2003	SH (NA) -080124-E	<p>Correction</p> <p>SAFETY PRECAUTIONS, About Manuals, Section 1.2, 2.1.2, 2.2.2, 2.3.2, 2.5, 3.1.1, 3.1.2, 3.2.2, 3.3.1, Chapter 5, Section 5.1.3, 5.1.5, 6.2, 6.3, 6.4, 6.5, 8.1, 8.2, 8.2.1, 8.2.5, 8.3.1</p>

* The manual number is given on the bottom left of the back cover.

Print Date	* Manual Number	Revision
Jun., 2004	SH (NA) -080124-F	<p>Correction</p> <p>SAFETY PRECAUTIONS, Manuals, Generic Terms And Abbreviations, Section 1.2, 2.1.2, 2.2.2, 2.3.2, 2.4.2, 2.5, 3.1.1, 3.1.2, 3.1.3, 3.1.4, 3.2, 3.2.2, 4.2.2, 4.9.1, 4.10, 4.10.1, 4.10.2, 4.10.3, Chapter 5, Section 5.1.1, 5.2, 5.2.1, 6.4, 6.5, Chapter 7, Section 8.1, 8.1.1, 8.1.2, 8.1.3, 8.1.4, 8.2.1, 8.2.3, 8.2.5, 8.2.7, 8.3.1, 8.3.2, Appendix 2, 3</p> <p>Addition</p> <p>Section 1.4, 2.4, 2.7, 3.3.3, 3.3.4, 7.11, 7.12, 8.2.7, Appendix 7</p> <p>Changed section No.</p> <p>Section 2.4 → Section 2.5, Section 2.5 → Section 2.6</p>
Mar., 2005	SH (NA) -080124-G	<p>Correction</p> <p>Safety Precautions, Conformation to the EMC Directive and Low Voltage Instruction, Product Configuration, Section 1.1, 1.2, 2.6, 2.7, 3.1.1, 3.1.2, 3.1.4, 3.2.2, 3.3.2, 4.2.1, 4.2.2, 4.3, 4.4, 4.8.1, 4.8.2, 4.9.1, 4.10.1, 5.1.4, 6.1.1, 6.2, 6.2.2, 6.3, 7.4, 8.1, 8.1.2, 8.1.3, 8.2, 8.2.1, 8.3.1, 8.3.2, Appendix 2, 3, 4, 5, 7</p> <p>Addition</p> <p>Section 8.2.8</p>
Sep., 2005	SH (NA) -080124-H	<p>Correction</p> <p>Generic Terms And Abbreviations, Section 1.2, Section 2.5, Section 3.2, 3.2.2, 3.3.2, Section 5.1.5, 5.2.1, Section 6.3, 6.5, Section 7.12, Section 8.2, 8.2.5, 8.3.1, 8.3.2, Appendix 3, 4, 5</p>
May, 2006	SH (NA) -080124-I	<p>Correction</p> <p>Generic Terms And Abbreviations, Section 1.1, Chapter 2, Section 2.2.1, 2.5, 3.1.1, 3.1.4, 4.2.1, 4.2.2, 5.1.3, 5.1.4, 5.1.5, 6.3, 6.4, 7.1.1, 8.1.2, 8.3.2, Appendix 5</p> <p>Addition</p> <p>Section 2.5.1, 2.5.2</p>
Sep., 2006	SH (NA) -080124-J	<p>Correction</p> <p>Section 2.1.2, 2.2.2, 2.3.2, 2.4.2, 4.2.1, 4.2.2, 8.3.2</p>

* The manual number is given on the bottom left of the back cover.

Print Date	* Manual Number	Revision
Nov., 2006	SH (NA) -080124-K	<p>Addition</p> <p>SAFETY PRECAUTIONS</p> <p>Correction</p> <p>Section 2.5.2, 3.2.2, 4.2.1, 4.2.2, 4.3, 4.8.1, 4.8.2, 5.1.5, 8.1.2, 8.2, 8.2.4, 8.3.2, Appendix 2, 3, 5</p> <p>Sections added</p> <p>Section 8.2.8, 8.4, 8.5</p> <p>Changed section No.</p> <p>Section 8.2.8 → Section 8.2.9, Section 8.4 → Section 8.6</p>
Oct., 2007	SH (NA) -080124-L	<p>Addition</p> <p>Chapter 1, Section 2.1.2, 2.2.2, 2.3.2, 2.4.2, 2.5.1, 2.5.2, 2.7, 3.3.1, 3.3.2, 4.8.2, Chapter 5, Section 5.1.4, 5.1.5, 8.2.1, 8.3.1, Appendix 2, 4, 5</p> <p>Correction</p> <p>SAFETY PRECAUTIONS , Generic Terms And Abbreviations, Section 2.2.1, 2.3.1, 2.4.1, 4.2.1, 4.7.1, 4.7.2, 4.7.3, 4.9.1, 5.1.1, 5.1.3, 6.1.1, 6.2, 6.3, 6.5, 6.6, 7.1.1, 7.12, 8.1, Appendix 3</p> <p>Sections added</p> <p>DEFINITIONS OF TERMINOLOGY, Section 6.4</p> <p>Changed section No.</p> <p>Section 6.4 to 6.5 → Section 6.5 to 6.6, Appendix 7 → Appendix 6</p>
Feb., 2008	SH (NA)-080124-M	<p>Correction</p> <p>Generic Terms And Abbreviations, Section 1.2, 2.1.2, 2.2.2, 2.3.2, 2.4.2, 2.5, 3.2.2, 3.3.2, 4.7, 4.8, 4.9.1, 5.1.1, 5.1.4 to 5.1.6, 5.2.1, 6.1.1, 6.5, 6.6, 7.1.1, 7.8, 7.11.4, 8.1, 8.3, 8.4, Appendix 2, 3, 5</p>
Sep., 2008	SH (NA)-080124-N	<p>Correction</p> <p>SAFETY PRECAUTIONS, Compliance with the EMC and Low Voltage Directives, Generic Terms And Abbreviations, DEFINITIONS OF TERMINOLOGY, Chapter1, Section 1.2, 1.3, 2.1.2, 2.1.3, 2.2, 2.2.1, 2.2.3, 2.3, 2.4.2, 2.4.3, 2.5.1, 2.6, 3.1.4, 3.2, 3.3.2, 3.3.4, 4.2.1, 4.2.2, 4.8, 4.9.1, Chapter 5, Section 5.1.3 to 5.1.5, 6.1.2, 6.5, 6.6, Chapter 7, 7.1.1, 7.10, 7.11, 7.11.1, 7.11.3, 7.11.4, Chapter 8, 8.1, 8.2, 8.2.5, 8.2.7, 8.3.1, 8.3.2, Appendix 2 to 6</p>

* The manual number is given on the bottom left of the back cover.

Print Date	* Manual Number	Revision
Aug., 2009	SH (NA) -080124-O	<p>Correction</p> <p>Generic Terms And Abbreviations, Section 1.3, 2.5.1, 2.7, 3.3.2, 6.4.2, Chapter 8</p> <p>Sections added</p> <p>Section 8.3.1</p> <p>Changed section No.</p> <p>Section 8.3.1(4) → Section 8.3.2, Section 8.3.2 → Section 8.3.3</p>
Sep., 2010	SH (NA) -080124-P	<p>Correction</p> <p>Generic Terms And Abbreviations, Section 1.3, 2.5.1, 2.5.2, 2.7, 3.3.2, 4.2.1, 4.2.2, 4.3, Chapter 5, Section 5.1.5, 5.1.6, 6.1.1, 8.2.9, 8.3.1, 8.3.2, 8.3.3, Appendix 2, 6</p> <p>Sections added</p> <p>CONDITIONS OF USE FOR THE PRODUCT</p>
Mar., 2011	SH (NA) -080124-Q	<p>Correction</p> <p>Section 3.1.4, 3.3.1, 8.3.2, Appendix 5</p>
Sep., 2012	SH (NA) -080124-R	<p>Correction</p> <p>SAFETY PRECAUTIONS, COMPLIANCE WITH THE EMC AND LOW VOLTAGE DIRECTIVES, GENERIC TERMS AND ABBREVIATIONS, PACKING LIST, Section 1.2, 1.4, 2.1.2, 2.2.2, 2.3.1, 2.3.2, 2.4.1, 2.4.2, 2.5.1, 2.5.2, 2.6, 2.7, 3.1.1, 3.1.2, 3.1.4, 3.2, 3.2.1, 3.2.2, 3.3.1, 3.3.2, 3.3.3, 3.3.4, 4.1, 4.2.1, 4.2.2, 4.3, 4.7, 4.8.1, 4.8.2, 4.9.1, 4.10, 4.10.1, 4.10.2, 4.10.3, Chapter 5, Section 5.1.1, 5.1.2, 5.1.3, 5.1.4, 5.1.5, 5.1.6, 5.2.1, 6.1.1, 6.1.2, 6.5, 6.6, Chapter 7, Section 7.11, 7.11.3, 7.11.4, 7.12, Chapter 8, Section 8.1, 8.1.1, 8.1.3, 8.2, 8.2.1, 8.2.4, 8.2.5, 8.3, 8.3.1, 8.3.2, 8.3.3, 8.4, 8.6, Appendix 1, 2, 3, 5, 6, INDEX</p>
Jul., 2013	SH (NA) -080124-S	<p>Correction</p> <p>SAFETY PRECAUTIONS, MANUALS, GENERIC TERMS AND ABBREVIATIONS, Chapter 1, Section 1.2, 1.3, 2.5.1, 2.5.2, 4.2.1, 4.2.2, 4.7, 4.7.1, 4.7.2, 4.7.3, 4.8.1, 4.10.1, 4.10.2, 4.10.3, 4.10.4, Chapter 5, Section 5.2.1, 6.1.1, 6.4.1, 6.6, 7.11, 7.12, 8.1.1, 8.1.2, 8.1.3, 8.1.4, 8.2.6, 8.3.1, 8.3.3, Appendix 1, 2, 3, 4, 5</p>

* The manual number is given on the bottom left of the back cover.

Print Date	* Manual Number	Revision
Feb., 2018	SH (NA) -080124-T	<p>Correction</p> <p>GENERIC TERMS AND ABBREVIATIONS, Section 2.7, 3.1.4, 3.3.2, 4.2.1, 4.2.2, Appendix 6</p>
Sep., 2019	SH (NA) -080124-U	<p>Addition</p> <p>Section 8.2.4</p> <p>Changed section No.</p> <p>Section 8.2.4 to Section 8.2.9 → Section 8.2.5 to Section 8.2.10</p>
Aug., 2022	SH (NA) -080124-V	<p>Correction</p> <p>Section 7.11, 8.3.2, Appendix 3</p> <p>Addition</p> <p>Section 8.2.11</p>
Nov., 2023	SH (NA) -080124-W	<p>Correction</p> <p>Section 4.2</p>

Japanese Manual Version SH-080123-AA

This manual confers no industrial property rights or any rights of any other kind, nor does it confer any patent licenses. Mitsubishi Electric Corporation cannot be held responsible for any problems involving industrial property rights which may occur as a result of using the contents noted in this manual.

© 2000 MITSUBISHI ELECTRIC CORPORATION

INTRODUCTION

Thank you for purchasing the Mitsubishi Electric MELSEC-Q series programmable controllers. Before using this product, please read this manual carefully and develop familiarity with the functions and performance of the MELSEC-Q series programmable controller to handle the product correctly. Note that the menu names and operating procedures may differ depending on an operating system in use and its version. When reading this manual, replace the names and procedures with the applicable ones as necessary.

CONTENTS

SAFETY PRECAUTIONS.....	A- 1
CONDITIONS OF USE FOR THE PRODUCT	A- 6
REVISIONS	A- 7
CONTENTS	A-12
MANUALS	A-17
COMPLIANCE WITH THE EMC AND LOW VOLTAGE DIRECTIVES.....	A-17
GENERIC TERMS AND ABBREVIATIONS	A-18
DEFINITIONS OF TERMINOLOGY	A-20
PACKING LIST.....	A-21

1 OVERVIEW	1- 1 to 1-11
-------------------	---------------------

1.1 Overview.....	1- 2
1.2 Features.....	1- 3
1.3 Abbreviations Used in the Text, Tables and Diagrams of This Manual	1-10
1.4 Functions Added/Changed with Upgrade to Function Version D.....	1-11

2 SYSTEM CONFIGURATION	2- 1 to 2-23
-------------------------------	---------------------

2.1 Single Remote I/O Networks.....	2- 1
2.1.1 Configuration	2- 1
2.1.2 Setting items	2- 2
2.1.3 Available device ranges	2- 3
2.2 Multiple Remote I/O Network (Process CPU)	2- 4
2.2.1 Configuration	2- 4
2.2.2 Setting items	2- 5
2.2.3 Available device ranges	2- 6
2.3 Multiplexed Remote I/O Network for Redundant System (Redundant CPU).....	2- 7
2.3.1 Configuration	2- 7
2.3.2 Setting items	2- 8
2.3.3 Available device ranges	2- 9
2.4 Multiple Remote I/O Network	2-10
2.4.1 Configuration	2-10
2.4.2 Setting items	2-11
2.4.3 Available device ranges	2-12
2.5 Applicable Systems	2-13
2.5.1 Applicable systems for remote master stations	2-13
2.5.2 Applicable systems for remote I/O stations.....	2-15
2.6 When Using a Multiple CPU System.....	2-19
2.7 Checking Function Version and Serial No.....	2-22

3 SPECIFICATIONS	3- 1 to 3-64
-------------------------	---------------------

3.1 Performance Specifications	3- 1
3.1.1 Optical loop system performance specifications	3- 1
3.1.2 Coaxial cable system performance specifications	3- 3
3.1.3 Optical fiber cable specifications.....	3- 4
3.1.4 Coaxial cable specifications	3- 5
3.2 Function Specifications	3-10
3.2.1 Cyclic transmission function (periodic communication)	3-11
(1) Communicating with I/O modules	3-11
(2) Communicating with intelligent function modules.....	3-12
3.2.2 RAS functions	3-17
(1) Output reset function for communication errors.....	3-17
(2) Hardware error time CPU operation mode setting	3-17
(3) Automatic return function.....	3-18
(4) Loopback function (optical loop system).....	3-19
(5) Station detach function (coaxial bus system)	3-21
(6) Transient transmission enabled even at CPU module error	3-22
(7) Abnormal detection time	3-23
(8) Diagnostic function.....	3-24
(9) Redundant power supply on a remote I/O station	3-25
(10) Online module change on a remote I/O station	3-28
3.3 Link Data Send/Receive Processing Time Specifications	3-34
3.3.1 Link data send/receive processing	3-34
3.3.2 Transmission delay time	3-40
3.3.3 Switching time from the multiplexed remote master station to the multiplexed remote sub-master station in a multiplexed remote I/O network.....	3-59
3.3.4 Output holding time during system switching in the multiplexed remote I/O network for redundant system	3-60

4 SETTING AND PROCEDURE BEFORE OPERATION	4- 1 to 4-37
---	---------------------

4.1 Procedure Before Operation	4- 1
4.2 Part Names and Settings	4- 2
4.2.1 QJ71LP21, QJ71LP21-25, QJ71LP21G, QJ71LP21GE, QJ71BR11 (Remote master station)	4- 2
4.2.2 QJ72LP25-25, QJ72LP25G, QJ72LP25GE, QJ72BR15.....	4- 6
4.3 Installing and Uninstalling the Module	4-11
4.4 Stopping the CPU (Unintentional Output Prevention).....	4-13
4.5 Checking the Input Power Supply Voltage	4-13
4.6 Powering On	4-13
4.6.1 Checking the on status of the POWER LED of the power supply module.....	4-13
4.6.2 Checking the on status of the RUN LED of the network module.....	4-13
4.7 Unit Tests of the Network Module (Offline Test)	4-14
4.7.1 Self-loopback test	4-15
4.7.2 Internal self-loopback test	4-17
4.7.3 Hardware test	4-19
4.8 Cable Connections	4-21
4.8.1 Optical loop system	4-21

4.8.2	Coaxial bus system	4-23
4.9	Offline Tests from GX Developer	4-28
4.9.1	Forward loop/reverse loop test (Remote master station only)	4-28
4.10	Network Diagnostics from GX Developer (Online Tests)	4-32
4.10.1	Loop test (optical loop system only)	4-33
4.10.2	Setup confirmation test.....	4-34
4.10.3	Station order check test (optical loop system only).....	4-35
4.10.4	Communication test.....	4-36

5 PARAMETER SETTINGS	5- 1 to 5-38
-----------------------------	---------------------

5.1	Remote Master Station Parameter Setting.....	5- 5
5.1.1	Setting the number of modules (Network type).....	5- 5
5.1.2	Network settings	5- 6
(1)	Starting I/O No.	5- 6
(2)	Network No.	5- 6
(3)	Total stations	5- 6
(4)	Group No. (Available for multiplexed remote master/sub-master station only)	5- 7
(5)	Mode.....	5- 7
(6)	Parameter setting example.....	5- 8
5.1.3	Common parameter	5- 9
(1)	LX/LY setting.....	5- 9
(2)	LB/LW setting.....	5-12
(3)	Reserved station specification.....	5-13
(4)	Remote sub-master station	5-13
5.1.4	Supplementary settings.....	5-15
5.1.5	Refresh parameters.....	5-19
5.1.6	Valid module during other station access.....	5-31
5.1.7	Redundant settings.....	5-32
5.2	Remote I/O Station Parameter Settings	5-33
5.2.1	Remote I/O station possible parameter settings	5-33

6 PROGRAMMING	6- 1 to 6-41
----------------------	---------------------

6.1	Programming Precautions	6- 1
6.1.1	Interlock related signals.....	6- 1
6.1.2	Program example	6- 4
6.2	Cyclic Transmission	6- 7
6.2.1	32-bit data assurance.....	6- 7
6.2.2	Block data assurance per station of cyclic data	6- 8
6.3	Communications with I/O Modules	6- 9
6.4	Communications with Intelligent Function Modules	6-10
6.4.1	Program example when using GX Configurator.....	6-11
6.4.2	Program example when not using GX Configurator	6-15
6.5	Link Dedicated Instruction List.....	6-18
6.6	Using the Link Special Relays (SB)/ Link Special Registers (SW).....	6-23

7.1	Transient Transmission Function (Non-Periodical Communication)	7- 2
7.1.1	Link dedicated instruction	7- 3
	(1) Reading/writing remote I/O station intelligent function module buffer memory (Z(P).REMFR/ Z(P).REMTO)	7- 3
7.2	Remote I/O Station System Monitor	7- 9
7.3	Device Test for Remote I/O Station	7-10
7.4	Multiplex Transmission Function (Optical Loop System)	7-12
7.5	Return Sequence Station Number Setting Function	7-13
7.6	Reserved Station Function	7-13
7.7	Interrupt Settings	7-14
7.8	I/O Assignment Function	7-15
7.9	Stopping/Restarting the Cyclic Transmission and Stopping Link Refreshing (Network Test)	7-16
7.10	Multiplexed Remote Master Function (Process CPU)	7-17
7.11	Multiplexed Remote Master Function for the Redundant System (Redundant CPU)	7-32
7.11.1	Backup function of master operation on system switching between control system and standby system	7-34
7.11.2	Master operation by the station that has started up as the control system	7-35
7.11.3	System switching request function of control system	7-36
7.11.4	Access function by specifying the control system or standby system	7-39
7.12	Remote password	7-40

8.1	Network Diagnostics (Network Monitor)	8- 2
8.1.1	Host information	8- 5
8.1.2	Other station information	8- 7
8.1.3	Network monitor details	8- 9
8.1.4	Error history monitor	8-12
8.2	Troubleshooting	8-15
8.2.1	Items checked first	8-21
8.2.2	Items checked when data link cannot be performed throughout the system	8-21
8.2.3	Items checked when data link is disabled by resetting or powering off a station	8-22
8.2.4	Items checked when cyclic data is 0 by resetting or powering on a station	8-22
8.2.5	Items checked when data link cannot be performed on a certain station	8-23
8.2.6	Items checked when an communication data error is detected	8-24
8.2.7	Items checked when a link dedicated instruction does not complete	8-24
8.2.8	Items checked when multiplexed remote I/O network for redundant system does not operate normally	8-25
8.2.9	Items checked when a minor error (continue error) on a remote I/O station cannot be detected	8-25
8.2.10	Checking incorrect optical fiber cable connection during online	8-26
8.2.11	When a communication error such as a CRC error occurs frequently	8-29
8.3	Error Codes	8-32
8.3.1	How to check error codes	8-32
8.3.2	MELSECNET/H error code list	8-38
8.3.3	Error codes detected on remote I/O stations and equivalent to CPU module error codes	8-47
8.4	Canceling a Minor Error (Continue Error) on a Remote I/O Station	8-56

8.4.1	Canceling a specific remote I/O station error	8-57
8.4.2	Canceling errors of all remote I/O stations	8-58
8.5	Procedure for Replacing a Normally Operating Redundant Power Supply Module	8-63
8.6	H/W Information.....	8-64

APPENDICES	App- 1 to App-53
------------	------------------

Appendix 1	Precautions for Replacing MELSECNET/10 Remote I/O Network with MELSECNET/H Remote I/O Network	App- 1
Appendix 2	Link Special Relay (SB)	App- 3
Appendix 3	Link Special Register (SW).....	App-14
Appendix 4	Special Relay (SM) for Remote I/O Stations.....	App-33
Appendix 5	Special Register (SD) for Remote I/O Module.....	App-36
Appendix 6	External Dimensions	App-50

INDEX	Index- 1 to Index- 2
-------	----------------------

MANUALS

The manuals related to this product are listed below.
Order each manual as needed, referring to the following lists.

Relevant manuals

Manual name	Manual number (model code)
Q Corresponding MELSECNET/H Network System Reference Manual (PLC to PLC network) Specifications, procedures and settings before system operation, parameter setting, programming, and troubleshooting of a MELSECNET/H network system (PLC to PLC network) (Sold separately)	SH-080049 (13JF92)
Q Corresponding MELSECNET/H Remote I/O Module Reference Manual (MELSECNET/10 Mode) Operating procedures, system configuration, parameter settings, functions, programming, and troubleshooting of the MELSECNET/H remote I/O module when used in MELSECNET/10 mode. (Sold separately)	SH-081164ENG (13JV30)

COMPLIANCE WITH THE EMC AND LOW VOLTAGE DIRECTIVES

(1) For programmable controller system

To ensure that Mitsubishi Electric programmable controllers maintain the EMC and Low Voltage Directives or other regulations when incorporated into other machinery or equipment, certain measures may be necessary. Please refer to one of the following manuals.

- QCPU User's Manual (Hardware Design, Maintenance and Inspection) (SH-080483ENG)
- Safety Guidelines (IB-0800423)

Certification marks on the side of the programmable controller indicate compliance with the relevant regulations.

(2) For the product

To ensure that this product maintains EMC and Low Voltage Directives or other regulations, please refer to one of the manuals listed under (1).

GENERIC TERMS AND ABBREVIATIONS

Generic term/abbreviation	Description
QJ71LP21	An abbreviation for the QJ71LP21, QJ71LP21-25, QJ71LP21S-25, QJ71LP21G, and QJ71LP21GE MELSECNET/H network module. However, especially in cases to show different models, the QJ71LP21, QJ71LP21-25, QJ71LP21S-25, QJ71LP21G and QJ71LP21GE are printed.
QJ71BR11	An abbreviation for the QJ71BR11 MELSECNET/H network module
QJ72LP25	An abbreviation for the QJ72LP25-25, QJ72LP25G, and QJ72LP25GE MELSECNET/H network modules. However, especially in cases to show different models, the QJ72LP25-25, QJ72LP25G and QJ72LP25GE are printed.
QJ72BR15	An abbreviation for the QJ72BR15 MELSECNET/H network module
Master module	A generic term for the QJ71LP21 and QJ71BR11
Remote I/O module	A generic term for the QJ72LP25 and QJ72BR15
Network module	A generic term for master module and remote I/O module
Ethernet module	An abbreviation for the QJ71E71, QJ71E71-100, QJ71E71-B5, and QJ71E71-B2 Ethernet interface modules
Serial communication module	An abbreviation for the QJ71C24N, QJ71C24N-R2, QJ71C24N-R4, QJ71C24, and QJ71C24-R2 serial communication modules
CC-Link IE Controller Network module	An abbreviation for the QJ71GP21-SX and QJ71GP21S-SX CC-Link IE Controller Network modules
CC-Link IE Field Network	An abbreviation for the QJ71GF11-T2 CC-Link IE Field Network module
MELSECNET/H	An abbreviation for the Q series MELSECNET/H network system
MELSECNET/10	An abbreviation for the AnU series MELSECNET/10 network system and QnA/Q4AR series MELSECNET/10 network system
QCPU	A generic term for the Basic model QCPU, High Performance model QCPU, Process CPU, Redundant CPU, and Universal model QCPU
Basic model QCPU	A generic term for the Q00JCPU, Q00CPU, and Q01CPU
High Performance model QCPU	A generic term for the Q02CPU, Q02HCPU, Q06HCPU, Q12HCPU, and Q25HCPU
Process CPU	A generic term for the Q02PHCPU, Q06PHCPU, Q12PHCPU, and Q25PHCPU (Indicated as QnPHCPU in figures.)
Redundant CPU	A generic term for the Q12PRHCPU and Q25PRHCPU (Indicated as QnPRHCPU in figures.)
Universal model QCPU	A generic term for the Q00UJCPU, Q00UCPU, Q01UCPU, Q02UCPU, Q03UDCPU, Q03UDVCPU, Q03UDECPU, Q04UDHCPU, Q04UDVCPU, Q04UDEHCPU, Q06UDHCPU, Q06UDVCPU, Q06UDEHCPU, Q10UDHCPU, Q10UDEHCPU, Q13UDHCPU, Q13UDVCPU, Q13UDEHCPU, Q20UDHCPU, Q20UDEHCPU, Q26UDHCPU, Q26UDVCPU, Q26UDEHCPU, Q50UDEHCPU, and Q100UDEHCPU
Built-in Ethernet port QCPU	A generic term for the Q03UDVCPU, Q03UDECPU, Q04UDVCPU, Q04UDEHCPU, Q06UDVCPU, Q06UDEHCPU, Q10UDEHCPU, Q13UDVCPU, Q13UDEHCPU, Q20UDEHCPU, Q26UDVCPU, Q26UDEHCPU, Q50UDEHCPU, and Q100UDEHCPU
Safety CPU	A generic term for the QS001CPU

Generic term/abbreviation	Description
C Controller module	A generic term for the C Controller modules: Q06CCPU-V-H01, Q06CCPU-V, Q06CCPU-V-B, Q12DCCPU-V, and Q24DHCCPU-V
QnACPU	A generic term for MELSEC-QnA series CPU modules
ACPU	A generic term for MELSEC-A series CPU modules
AnUCPU	A generic term for the MELSEC-A series CPU modules: A2UCPU, A2UCPU-S1, A3UCPU, A4UCPU, A2USCPU, A2USCPU-S1, and A2USHCPU-S1
Q3□B	A generic term for the Q33B, Q35B, Q38B and Q312B main base units
Q3□SB	A generic term for the Q32SB, Q33SB and Q35SB slim type main base units
Q3□RB	Another term for the Q38RB main base units for the redundant power supply system
Q5□B	A generic term for the Q52B and Q55B extension base units
Q6□B	A generic term for the Q63B, Q65B, Q68B and Q612B extension base units
Q6□RB	Another term for the Q68RB extension base units for the redundant power supply system
Q6□WRB	Another term for the Q65WRB redundant type extension base units
QA1S6□B	A generic term for the QA1S65B and QA1S68B extension base units
Q6□P	A generic term for the Q61P, Q61P-A1, Q61P-A2, Q62P, Q63P, Q64P, and Q64PN power supply modules
Q6□RP	A generic term for the Q61P, Q63RP and Q64RP power supply modules for the redundant power supply system
Redundant power supply module	
GX Developer	A generic product name for SWnD5C-GPPW-J, SWnD5C-GPPW-JA, SWnD5C-GPPW-JV, and SWnD5C-GPPW-JVA ("n" means version 4 or later.) "-A" and "-V" mean "volume license product" and "version-upgrade product" respectively.
GX Works2	A generic product name for SWnDND-GXW2 and SWnDNC-GXW2 (n: version)
GX Configurator	An abbreviation for the GX Configurator software package
REMFR	An abbreviation for the Z.REMFR and ZP.REMFR
REMT0	An abbreviation for the Z.REMT0 and ZP.REMT0
Tracking cable	An abbreviation for the QC10TR and QC30TR tracking cables

DEFINITIONS OF TERMINOLOGY

Term	Description
Cyclic transmission	Function by which data communications are performed periodically between a remote master station and remote I/O stations using link devices (LB/LW/LX/LY) of network modules.
Transient transmission	This function allows communication with another station's programmable controller when a request is made with a link dedicated instruction or from GX Developer. Communications can be made with programmable controllers on the same or other networks.
Link dedicated instruction	Dedicated instruction used for transient transmission.
RAS	An abbreviation for Reliability, Availability, and Serviceability. This term is used to express the overall usability of automation systems.
Remote master station	Master station on a remote I/O network
Remote I/O station	Station that performs cyclic transmission according to the range assignment of the remote master station.
MELSECNET/10 mode	A mode to operate the MELSECNET/H remote I/O module on the MELSECNET/10 remote I/O network
MELSECNET/H (MELSECNET/10 mode) remote I/O station	A remote I/O station where the MELSECNET/H remote I/O module is being operated in MELSECNET/10 mode
Reserved station	Station that is not actually connected to the network. It must be included in the total number of stations in the network, since it is to be connected in the future.
Relay station	Station that relays transient transmission data to another network. Link device data of a network module are transferred to another network module via this station. Multiple network modules are connected to one programmable controller.
Reconnection	Processing of restarting data link when a faulty station becomes normal.
Disconnection	Processing of stopping data link when a data link error occurs.
Device	Devices (X, Y, M, D, etc.) that are contained in a CPU module.
Link Device	Devices (LB/LW/LX/LY) that are contained in a network module.
Link scan time	Time required for data of each station to be sent in order and to make one rotation in the network. The link scan time changes depending on the data volume or transient transmission request.
Link refresh	On the remote master station, data are transferred between the master module's link devices and the CPU module's devices. Link refresh means this processing. Link refresh is performed in "END processing" of the sequence scan of the CPU module.
I/O refresh	On a remote I/O station, data are transferred between remote I/O module's link devices and the following devices. I/O refresh means this processing. <ul style="list-style-type: none"> • I/O module's devices • Intelligent function module's devices
Automatic refresh	On a remote I/O station, data are transferred between remote I/O module's link devices and intelligent function module's devices. Automatic refresh means this processing.
Buffer memory	Memory area in an intelligent function module, in which data are temporarily stored. The network module does not have any buffer memory area that is offered to the user.
Baton pass	A control mechanism in which transmission right (token) is passed around the network for data transmission.
Group No.	Number that is assigned for transient transmission to any given stations. By specifying a group of stations as transient transmission target, data can be sent to the stations of the same group No.

PACKING LIST

Model name	Part name	Quantity
QJ71LP21	QJ71LP21 MELSECNET/H Network Module (optical loop type)	1
QJ71LP21-25	QJ71LP21-25 MELSECNET/H Network Module (optical loop type)	1
QJ71LP21S-25	QJ71LP21S-25 MELSECNET/H Network Module (optical loop type, with external power supply function)	1
QJ71LP21G	QJ71LP21G MELSECNET/H Network Module (optical loop type)	1
QJ71LP21GE	QJ71LP21GE MELSECNET/H Network Module (optical loop type)	1
QJ71BR11	QJ71BR11 MELSECNET/H Network Module (coaxial bus type)	1
	F-type connector (A6RCON-F)	1
QJ72LP25-25	QJ72LP25-25 MELSECNET/H Network Module (optical loop type)	1
QJ72LP25G	QJ72LP25G MELSECNET/H Network Module (optical loop type)	1
QJ72LP25GE	QJ72LP25GE MELSECNET/H Network Module (optical loop type)	1
QJ72BR15	QJ72BR15 MELSECNET/H Network Module (coaxial cable bus type)	1
	F-type connector (A6RCON-F)	1

*1: Production of the QJ71LP21 was discontinued in October, 2000.

REMARKS

For the coaxial bus system, terminating resistors (75 Ω) are required in the network terminal stations.
 Terminating resistors are not included with the QJ71BR11, QJ72BR15; they must be purchased separately.
 For a list of the model and how to use the terminating resistors, refer to Section 4.8.2.

1 OVERVIEW

The MELSECNET/H system includes the following 2 types of networks:

- 1) PLC to PLC network for communications between a control station and normal stations
- 2) Remote I/O network for communications between a remote master station and remote I/O stations

This is the manual to read when building a remote I/O network for MELSECNET/H systems (hereinafter referred to as MELSECNET/H). For building a MELSECNET/H PLC to PLC network, please refer to the Q Corresponding MELSECNET/H Network System Reference Manual. (PLC to PLC network) (SH-080049)

POINT

The Basic model QCPU and safety CPU cannot configure a remote I/O network in a MELSECNET/H network system.

REMARKS

- (1) The previous network, called MELSECNET/10H is now called MELSECNET/H.
- (2) A network module installed on the remote master station is referred to as a master module.
A network module installed on a remote I/O station is referred to as a remote I/O module.

1.1 Overview

1

The MELSECNET/H remote I/O network system has more functionality and capacity than the former network system, MELSECNET/10 network system (hereafter referred to as MELSECNET/10).

As the MELSECNET/H remote I/O network adopts the same module mounting method as the usual one (mounting I/O modules and intelligent function modules onto the main and extension base units), each module mounted on the remote I/O stations can be handled in the similar way as the basic one.

In addition, the usability of the MELSECNET/10 remote I/O network has been further enhanced so that networks can be easily configured for factory automation systems. For the optical loop system in the MELSECNET/H remote I/O network, the communication speed can be set to 25 Mbps or 10 Mbps.

	Network system	Communication speed
MELSECNET/H	Optical loop * 1	25 Mbps
	Optical loop, coaxial bus	10 Mbps

* 1: QJ71LP21-25, QJ71LP21S-25, and QJ72LP25-25 only

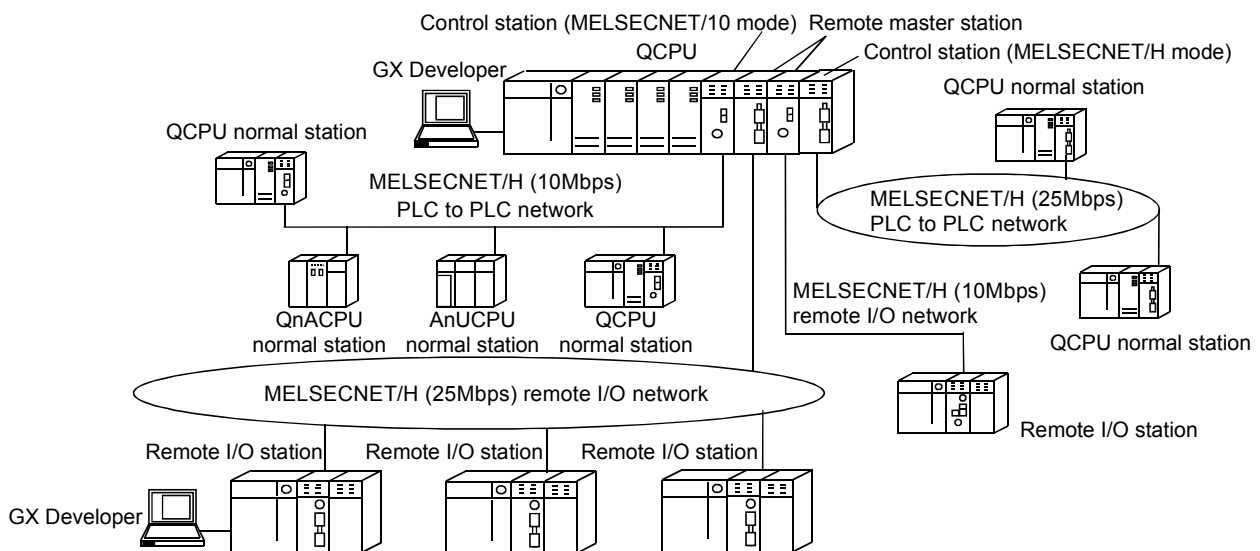

POINT
(1) Select QCPUs for MELSECNET/H remote I/O networks.
(2) Remote I/O networks and PLC to PLC networks cannot be mixed on the same MELSECNET/H network. Always build separate networks.
(3) Only MELSECNET/H network modules can be connected to a MELSECNET/H remote I/O network. Any MELSECNET/10 network modules (AJ72LP25, A1SJ72QLP25, etc.) are not connectable.

The following table shows the types of networks the CPU modules can be connected to.

CPU module	Type of networks that can be used with CPU	Network to be connected			
		MELSECNET/10		MELSECNET/H	
		PLC to PLC network	Remote I/O network	PLC to PLC network	Remote I/O network
QCPU	MELSECNET/H (10 Mbps)	○ (MELSECNET/10 mode)	×	○ (MELSECNET/H mode, MELSECNET/H Extended mode)	○
	MELSECNET/H (25 Mbps)	×	×		
AnUCPU	MELSECNET/10	○	○	×	×
QnACPU	MELSECNET/10				

○: Can be used ×: Cannot be used

1.2 Features

The MELSECNET/H remote I/O network has the following features.

(1) Realization of a high-speed communication system

- (a) High-speed data communication at 10 Mbps/25 Mbps is possible. (25Mbps is available for only the optical loop type QJ71LP21-25, QJ71LP21S-25 and QJ72LP25-25.)

(2) Large-scale and flexible system configuration

- (a) The link device has a larger capacity: 16384 points for the link relay (LB), 16384 points for the link register (LW), and 8192 points for the link inputs (LX)/link outputs (LY). (Refer to Section 2.1.3, "Available device range settings.")
- (b) A maximum of 4096 I/O points can be set for each remote I/O station. The link points between a remote master station and a remote I/O station can be set up to 1600 bytes. The link points of up to 2000 bytes can be set between a master station and a sub-master station on a multiplexed remote I/O network.
- (c) Either of the following systems can be chosen: the optical loop system which allows a long station-to-station distance and total distance (up to 30 km) and is resistant to noise, or the coaxial bus system (maximum cable distance of 500 m) which can be wired easily. (Refer to Section 3.1, "Performance Specifications.")

- (d) The following functions facilitate network connection:
- 1) Any station to be connected in the future can be specified as a reserved station.
Specifying a station not actually connected as a reserved station prevents a communication error. (Refer to Section 5.1.3 "Common parameter.")
 - 2) It is not necessary to connect stations in order of the station Nos. in the network. (Refer to Section 4.2.1, 4.2.2.)
- (e) The parameters can be written to remote I/O modules using GX Developer in the same way as to CPU modules.
The parameters of the remote I/O module can be used to change the detailed settings (response time, error time output mode) for I/O modules on the remote I/O station, intelligent function module switch settings and I/O assignments, and remote password settings.
(Refer to Section 5.2 "Remote I/O Station Parameter Settings".)
- (f) Setting up a master station (DM_R) and a sub-master station (DSM_R) on the multiplexed remote I/O network allows the sub-master station to take over the control of remote I/O stations (R) in case of the master station's failure.
(The Process CPU should be used for the multiplexed remote master station and sub-master station.)
By making a parameter setting, the multiplexed remote sub-master station can continue the control of the remote I/O stations even if the master station has recovered to normal and rejoined to the system. (Setting for the recovered master station to control the remote I/O stations is also available.)
(Refer to Section 7.10 "Multiplex Remote Master Function (Process CPU)".)

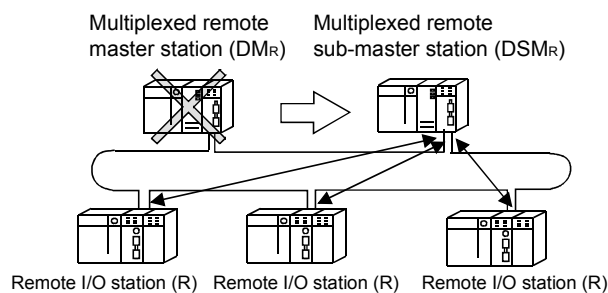

- (g) The redundant system uses the multiplex remote master function to control I/O modules and intelligent function modules. (The Redundant CPU should be used in the redundant system.)

If the multiplexed master station (control system) fails, the multiplex remote master function will switch the master station from "control system" to "standby system". At this time, the multiplexed remote sub-master station is switched from "standby" to "control", continuing the remote I/O control. The sub-master station (control system) that is controlling the remote I/O stations will keep its control even if the master station (standby system) has returned to normal status.

(Refer to Section 7.11 "Multiplex Remote Master Function for Redundant System (Redundant CPU)".)

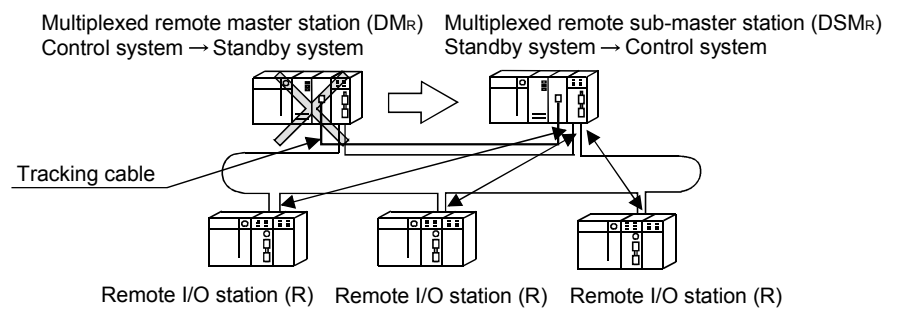

- (h) A maximum of 7 extension base units can be connected to the remote I/O module (eight base units including the main base unit), allowing the installation of up to 64 modules.

The maximum overall length of extension cables is 13.2m, ensuring a flexible layout of extension base units.

(3) Providing versatile communication services

(a) Reading data from and writing data to intelligent function modules mounted on remote I/O stations are easy.

There are four methods available for reading and writing.

- 1) Use GX Configurator to make the initial settings and automatic refresh settings with intelligent function module parameters, and write them into the remote I/O module in the remote I/O station. By refreshing the intelligent function module data to the link register W of the remote I/O module based on the auto refresh settings, the remote master station can read/write refreshed data by cyclic transmission.

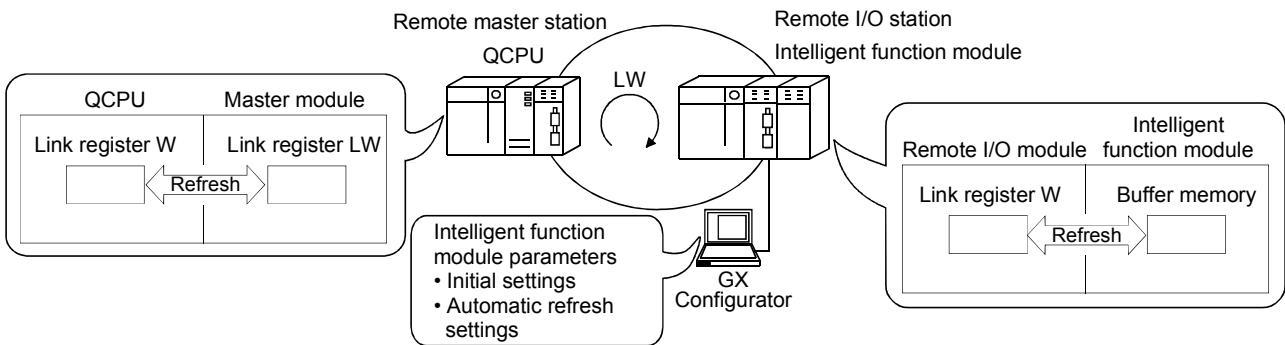

2) Link dedicated instructions can be used to directly read from or write to the buffer memory of the intelligent module.

- REMFR instruction: Reads data from the buffer memory of the remote I/O station intelligent function module.
- REMTO instruction: Writes data to the buffer memory of the remote I/O station intelligent function module.

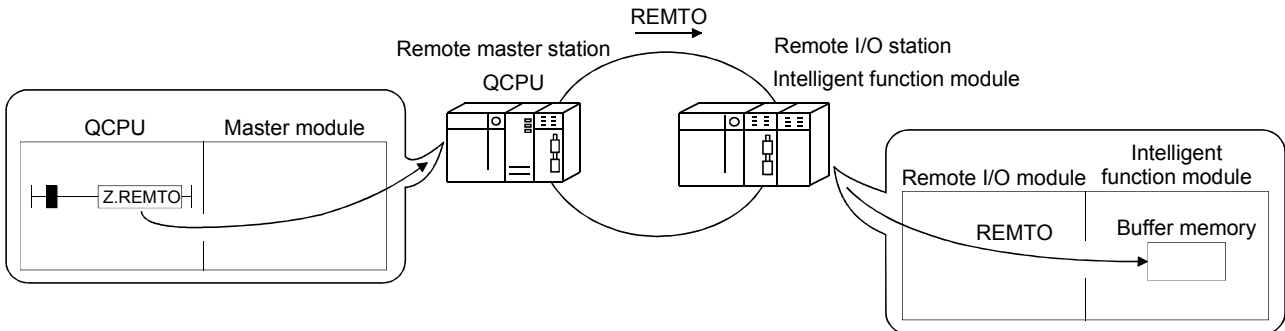

- 3) By refreshing the intelligent function module data into the remote I/O module's data register D by the automatic refresh setting of the intelligent function module parameters, the remote master station can read/write data from/to the data register D with READ or WRITE instruction.

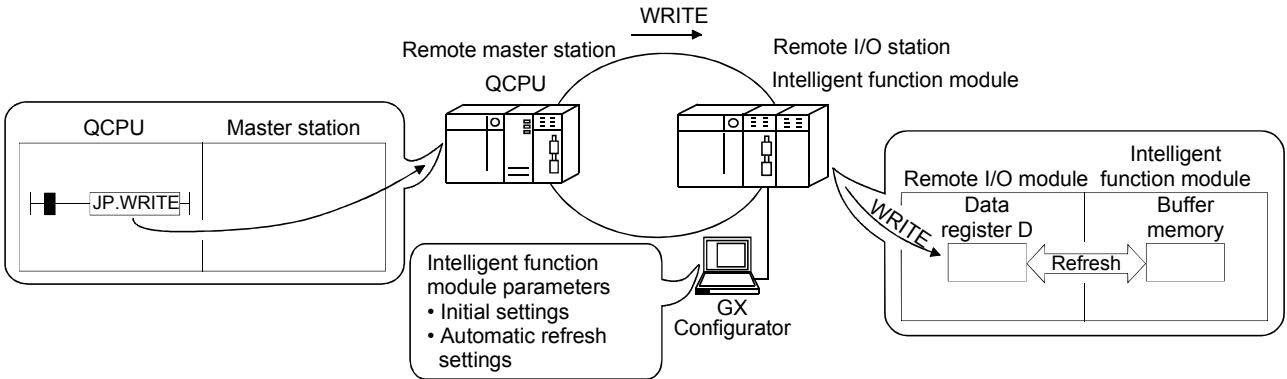

- 4) The automatic refresh setting of the intelligent function parameters enables the intelligent function module data to be refreshed into the remote I/O module's data register D. By refreshing the data register D to the link register W with the parameter of the remote I/O module, the remote master station can read/write the intelligent function module data by cyclic transmission. This method has the advantage that the intelligent function module parameters created for a QCPU can be applied to the remote I/O module without making any modifications.

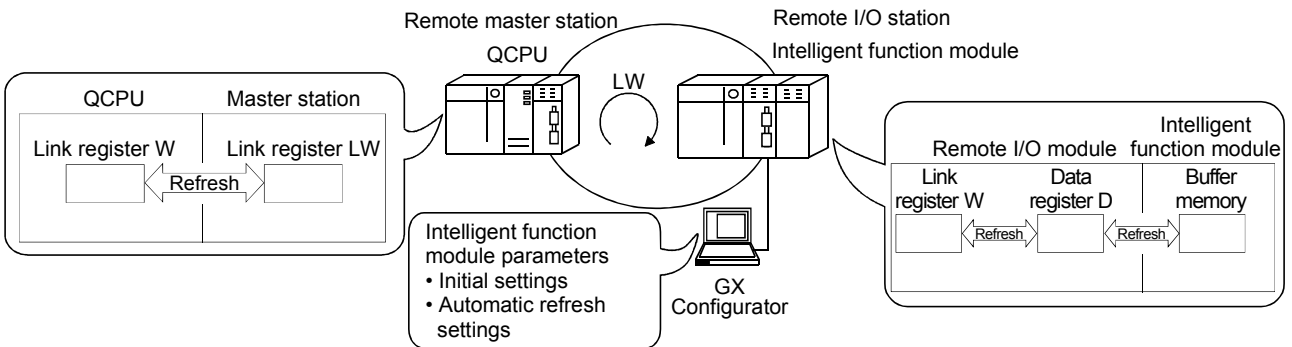

- (b) The interrupt sequence program of the host's CPU module can be started up using the event issue function. This function reduces the response time of the system and enables real-time data reception. (Refer to Section 7.7 "Interrupt Settings".)

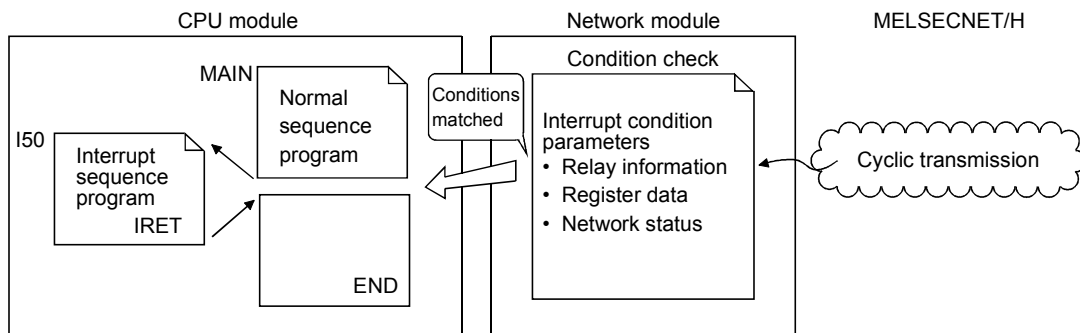

- (4) Enhanced RAS functions (Refer to Section 3.2.2 "RAS functions")
- (a) When a faulty station recovers and can resume normal operation, it automatically returns to the network to resume the data communication using the automatic return function.
 - (b) By using the loopback function (in the optical loop system), it is possible to continue data transmission among operational stations by disconnecting faulty areas such as a part of the network where there is a cable disconnection, a faulty station, etc.
 - (c) By using the station detach function (in the coaxial bus system), even when some of the connected stations are down due to power off, etc., the normal communication can be continued among other operational stations.
 - (d) The network module can continue the transient transmission even if an error, which stops the CPU module, occurs during system operation.
 - (e) The time of transient error occurrence can be checked.
 - (f) By mounting 2 power supply modules on a remote I/O station, either of them can be replaced without powering off the station. (Redundant power supply on remote I/O station)
The redundant power supply base unit is required for mounting 2 power supply modules.
 - (g) When an input module, an output module or an intelligent function module mounted on a remote I/O station fails, the faulty module can be replaced without stopping the system operation. (Online module change)
Online module change is executable for the Q series I/O modules and modules of function version C and later, such as analog-to-digital converter modules, digital-to-analog converter modules, channel isolated thermocouple input modules, and temperature control modules.

REMARKS

The following faults make the RAS functions valid.

- Break in cable
- Power-off of slave station
- Network setting error
- Fault detectable by self-diagnostics of CPU module

If the network module has become faulty, the RAS functions may not be activated depending on the fault.

- (5) Control of external connection to remote I/O stations (refer to Section 7.12)

Setting a remote password for a remote I/O station restricts access from the outside via an Ethernet interface module or serial communication module.

(Remote password)

(6) Improved network functions

- (a) Intelligent function modules mounted to remote I/O stations can be diagnosed using the GX Developer system monitor. Intelligent function modules mounted to remote I/O stations can be diagnosed using the system monitor of GX Developer, which is connected to a remote master station or directly connected to a remote I/O station.

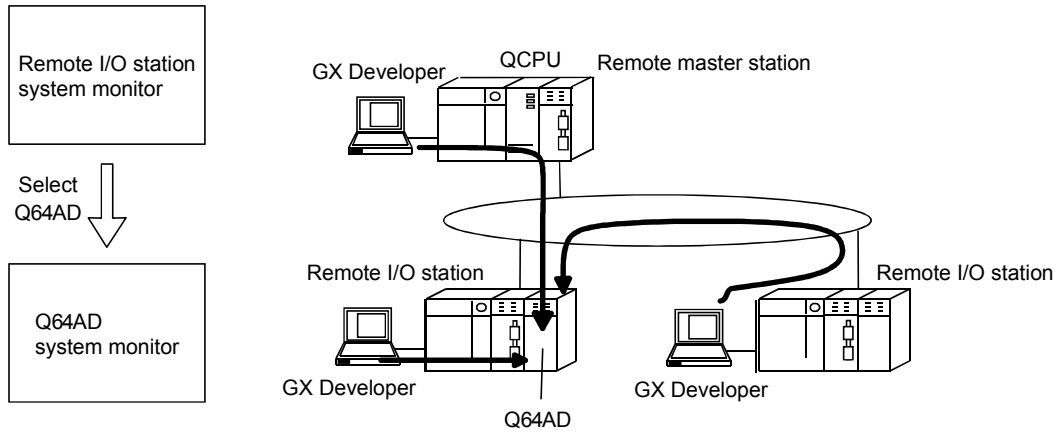

When the network seems to be faulty, it can be diagnosed through GX Developer connected to the remote master station or any remote I/O station.

- (b) If the GX Developer is connected to a remote I/O station, it will not affect the system operating so user program network function testing can be done online. It shuts out input (X) from the input module on the remote I/O station and can turn input (X) on or off using the GX Developer test. This allows testing of the remote master station input program to be performed. In addition, it shuts of output (Y) form the remote master station and can turn remote I/O station output (Y) on and off using the GX Developer test. This allows testing of the wires for the output module on the remote I/O station to be performed.

(7) Increased ease of network configuration in combination with GX Developer

- (a) The network parameters can easily be set by visualizing them as pull-down menus, dialogue boxes, etc.
- (b) The settings of network Nos., group numbers and operation modes have been simplified so that these values can be designated only through software settings.

(Network parameters)

	Module 1	Module 2
Network type	MNET/H(Remote master)	None
Starting I/O No.		0000
Network No.		None
Total stations		5
Group No.		
Station No.		
Mode	On line	
	Network range assignment	
	Refresh parameters	
	Interrupt settings	

Abbreviations {

Pull-down menu

1.3 Abbreviations Used in the Text, Tables and Diagrams of This Manual

(1) Abbreviations

Abbreviation	Name
M _R	Remote master station
R	Remote I/O station
DM _R	Multiplexed remote master
DSM _R	Multiplexed remote sub-master

(2) Marking format

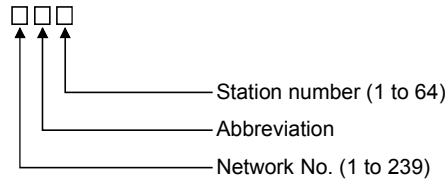

[Example]

- 1) Network No. 3 and remote master station 3M_R
 * : Station number "0" is not attached to the remote master station.
- 2) Network No. 5, remote I/O station, station number 3 5R3
- 3) Network No. 7, Multiplexed remote sub-master, station number 4
 7DSM_R4

1.4 Functions Added/Changed with Upgrade to Function Version D

The following table lists the additional/alterd functions for network modules of function version D.

Function	Function version	Description	Reference
Multiplexed remote I/O network for redundant system	Function version D	Allows construction of a multiplexed remote I/O network that includes the redundant system as the master station.	Section 7.11
Power supply redundancy on remote I/O station	Function version D	Allows the construction of the system that includes a remote I/O station in which 2 power supply modules are mounted for power supply redundancy.	Section 3.2.2 (9)
Online module change on remote I/O station	Function version D	Allows the faulty I/O module or intelligent function module on a remote I/O station to be replaced online while the remote I/O station is running.	Section 3.2.2 (10)
Remote password on remote I/O station	Function version D	Limits the access made from GX Developer via an Ethernet module or serial communication module mounted on a remote I/O station, by setting a password.	Section 7.12

2 SYSTEM CONFIGURATION

This introduces a system comprised of remote I/O networks.

POINT
(1) Remote I/O networks and PLC to PLC networks cannot be mixed on the same MELSECNET/H network. Always build separate networks.
(2) Only MELSECNET/H network modules can be connected to a MELSECNET/H remote I/O network. They cannot be mixed with MELSECNET/10 network modules (AJ72LP25, A1SJ72QLP25, etc.).

2

2.1 Single Remote I/O Networks

2.1.1 Configuration

(1) Optical loop system

Up to 64 remote I/O modules can be connected to a remote master station.

Always set the station number of the remote master station to 0.

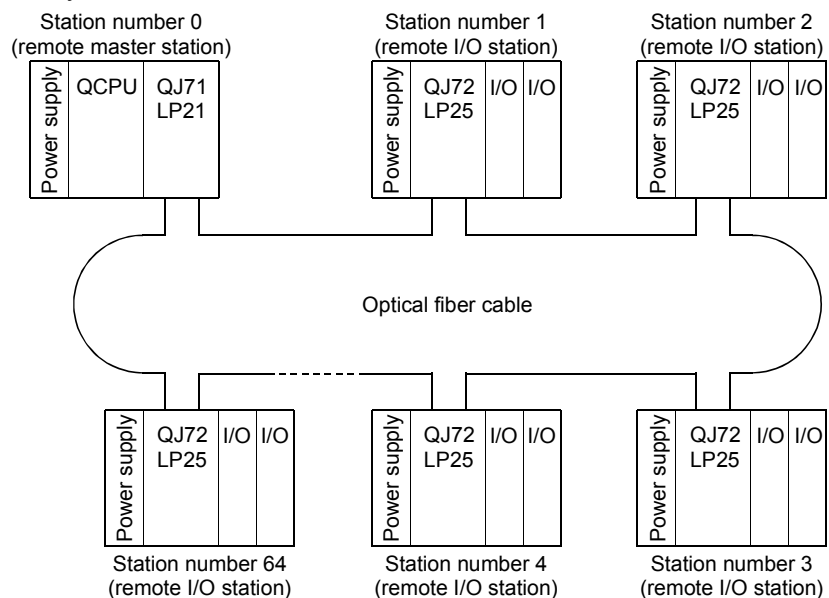

(2) Coaxial cable bus system

Up to 32 remote I/O stations can be connected to a remote master station.

Always set the station number of the remote master station to 0.

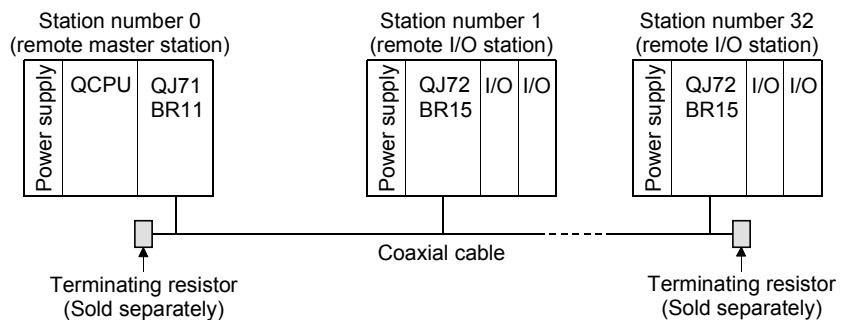

2.1.2 Setting items

- (1) Table 2.1 lists the setting items on the master module of the remote master station (MR) and the parameter setting items on GX Developer.

Table 2.1 Remote master station setting items

Setting items	Remote master station (MR)	Reference
Network module switch		
STATION NO.	0	Section 4.2.1
MODE	●	Section 4.2.2
Parameter setting on GX Developer		
Setting the number of Ethernet/CC IE/MELSECNET cards		
Network type	MELSECNET/H (Remote master station)	Section 5.1.1
Starting I/O No.	●	Section 5.1.2
Network No.	●	Section 5.1.2
Total stations	●	Section 5.1.2
Group No.	×	—
Mode	●	Section 5.1.2
Common parameters	●	Section 5.1.3
Supplementary setting	△	Section 5.1.4
Station specific parameters	×	—
Refresh parameters	● * 1 * 2	Section 5.1.5
Valid module during other station access	△	Section 5.1.6
Interlink transmission parameters	×	—
Routing parameters	△	* 3

●: Always set, ▲: Default setting, △: Set as needed, ×: No need to set

* 1: Default values are not set in LX/LY. Set the refresh parameters.

* 2: Default values are preset for LB/LW.

The CPUs other than the Universal model QCPU may operate even if refresh parameters have not been set.

For the operation and precautions, refer to Section 5.1.5 (3).

* 3: Refer to the Q Corresponding MELSECNET/H Network System Reference Manual (PLC to PLC Network) (SH-080049).

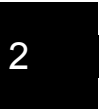

2.2 Multiple Remote I/O Network (Process CPU)

2.2.1 Configuration

A multiplexed remote I/O network system includes a multiplexed remote master station and a multiplexed remote sub-master station. The multiplexed remote sub-master station takes control of remote I/O stations when the multiplexed remote master station fails.

Always assign station No. 0 to the multiplexed remote master station.

It is allowed to assign any of station number 1 to 64 to the multiplexed remote sub-master station, provided that the number is not the same as that of remote I/O station. Sixty-three remote I/O stations can be connected in an optical loop system, 31 stations in a coaxial bus system.

POINT

Only the Process CPU is the CPU module that works as a multiplexed remote master station and multiplexed remote sub-master station.
 The CPUs other than the Process CPU do not work as a multiplexed remote master station and multiplexed remote sub-master station.

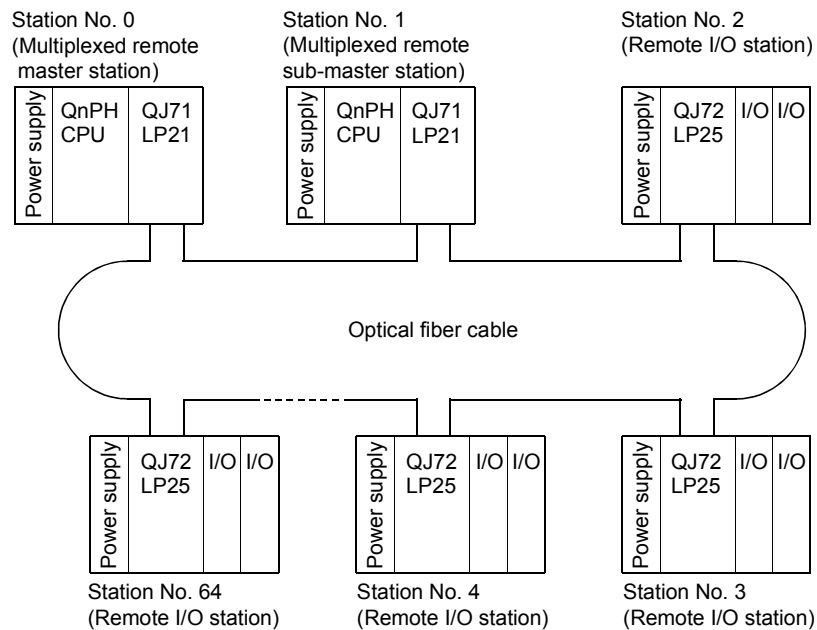

Up to 63 remote I/O stations can be connected in an optical loop system.
 Up to 31 stations can be connected in a coaxial bus system.

2.2.2 Setting items

- (1) Table 2.3 lists the parameter setting items of the multiplexed remote master station (DM_R) and multiplexed remote sub-master station (DSM_R).

Table 2.3 Setting Items of Multiplexed Remote Master Station and Multiplexed Remote Sub-Master Station

Setting item	Multiplexed remote master station (DM _R)	Multiplexed remote sub-master station (DSM _R)	Reference
Network module switch			
STATION NO.	0	1 to 64	Section 4.2.1
MODE	●	●	Section 4.2.1
Parameter setting on GX Developer			
Setting the number of Ethernet/CC IE/MELSECNET cards			
Network type	MELSECNET/H (Multiplexed remote master station)	MELSECNET/H (Multiplexed remote sub-master station)	Section 5.1.1
Starting I/O	●	●	Section 5.1.2
Network No.	●	●	Section 5.1.2
Total stations	●	△ * 1	Section 5.1.2
Group No.	△	△	Section 5.1.2
Mode	●	●	Section 5.1.2
Common parameters	●	△ * 1	Section 5.1.3
Supplementary setting	△	△	Section 5.1.4
Station specific parameters	×	×	—
Refresh parameters	● * 2 * 3	● * 2 * 3	Section 5.1.5
Valid module during other station access	△	△	Section 5.1.6
Interlink transmission parameter	×	×	—
Routing parameters	△	△	* 4

●: Always set, ▲: Default setting, △: Set as needed, ×: No need to set

POINT
<p>* 1: Set Total stations and common parameters of the multiplexed remote sub-master station when using the multiplexed remote sub-master station to resume the network. The settings must be the same as those of the multiplexed remote master station.</p> <p>For example, if the multiplexed remote master station is powered off and then on during network control by the multiplexed remote sub-master station, the multiplexed remote sub-master station resumes networking as a master operating station.</p>

* 2 : Default values are not set in LX/LY. Set the refresh parameters.

* 3 : Default values are preset for LB/LW.

The system may operate even if refresh parameters have not been set.

For the operation and precautions, refer to Section 5.1.5 (3).

* 4 : Refer to the Q Corresponding MELSECNET/H Network System Reference Manual (PLC to PLC Network) (SH-080049).

2.3 Multiplexed Remote I/O Network for Redundant System (Redundant CPU)

2.3.1 Configuration

The redundant system including the Redundant CPU utilizes the multiplexed remote I/O network system in order to control I/O modules and intelligent function modules. In the multiplexed remote I/O network system for the redundant system, the master module on the side of the control Redundant CPU (started up as a control system) acts as a multiplexed remote master station and controls remote I/O stations, while the master module mounted on the side of the standby Redundant CPU performs the sub-master operation as a multiplexed remote sub-master station.

When the control system CPU or the multiplexed remote master station goes down, the multiplexed remote sub-master station switches from "standby" to "control" and takes over the control of the remote I/O stations.

Make sure to assign No.0 to the master module mounted on the system A CPU in the redundant system.

For the station No. of the multiplexed remote sub-master station, set any of No. 1 to 64, which should not be the same as the station No. of the remote I/O stations.

The number of remote I/O stations connectable to a multiplexed remote I/O network for the redundant system is 63 in the optical loop system and 31 in the coaxial bus system.

POINT
The CPU module applicable for the multiplexed remote master or sub-master station in the redundant system is the Redundant CPU only. The CPUs other than the Redundant CPU are not applicable.

REMARKS

Refer to the QnPRHCPU User's Manual (Redundant System) for details on the redundant system.

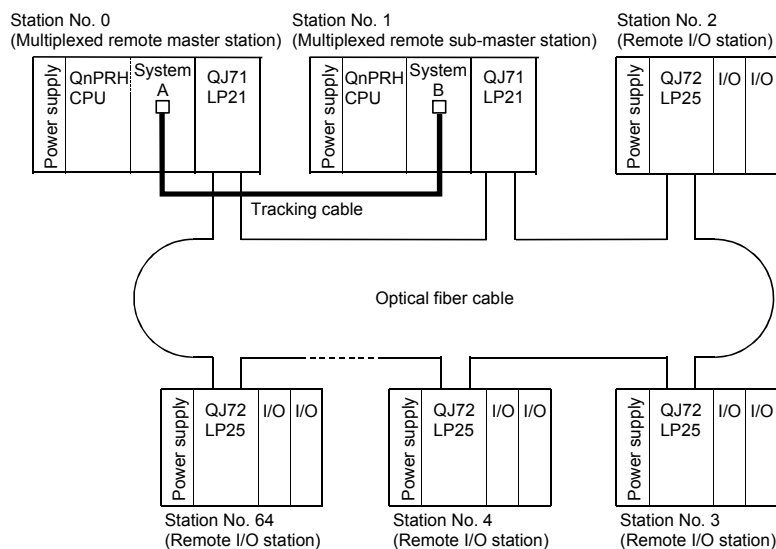

In the optical loop system, up to 63 remote I/O stations can be connected. Connection of up to 31 stations is allowed for the coaxial bus system.

2.3.2 Setting items

- (1) Table 2.5 lists the parameter setting items of the multiplexed remote master station (DM_R) and multiplexed remote sub-master station (DSM_R).
 In the redundant system, the same network parameters are set to both the control and standby systems. For this reason, parameter setting for the multiplexed remote sub-master station is not required.
 Make sure to assign No.0 to the master module mounted on the system A CPU in the redundant system.

Table 2.5 Setting Items of a Multiplexed Remote Master Station and a Multiplexed Remote Sub-master Station

Setting items	Remote master station (M _R)	Remote sub-master station (DSM _R)	Reference
Tracking cable connector	System A	System B	Section 7.1.1
Network module switch			
STATION NO.	0	1 to 64	Section 4.2.1
MODE	●	●	Section 4.2.1
Parameter setting on GX Developer			
Setting the number of Ethernet/CC IE/MELSECNET cards			
Network type	MELSECNET/H (Remote master station)	×	Section 5.1.1
Starting I/O No.	●	×	Section 5.1.2
Network No.	●	×	Section 5.1.2
Total stations	●	×	Section 5.1.2
Group No.	×	×	—
Mode	●	×	Section 5.1.2
Common parameters	●	×	Section 5.1.3
Supplementary setting	△	×	Section 5.1.4
Station specific parameters	×	×	—
Refresh parameters	● * 1 * 2	×	Section 5.1.5
Valid module during other station access	△	×	Section 5.1.6
Interlink data transfer parameters	×	×	—
Setting of redundant configuration	●	×	Section 5.1.7
Routing parameters	△	×	* 3

●: Always set, ▲: Default setting, △: Set as needed, ×: No need to set

- * 1: Default values are not set in LX/LY. Set the refresh parameters.
 * 2: Default values are preset for LB/LW.
 The system may operate even if refresh parameters have not been set.
 For the operation and precautions, refer to Section 5.1.5 (3).
 * 3: Refer to the Q Corresponding MELSECNET/H Network System Reference Manual (PLC to PLC Network) (SH-080049).

- (2) Table 2.6 lists the setting items on the remote I/O module, parameter setting items on GX Developer and intelligent function module parameter setting items on GX Configurator.

Table 2.6 Setting Items of a Remote I/O Station

Setting item	Remote I/O station (R)	Reference
Network module main module switch		
STATION NO.	1 to 64	Section 4.2.2
MODE	●	Section 4.2.2
GX Developer parameter setting		
PLC system	▲	* 4
PLC RAS	▲	* 4
I/O assignment	△	* 4
Operation setting	△	Section 5.2.1
Ethernet setting	△	* 5
CC-Link setting	△	* 6
Remote password setting	△	Section 7.12
GX Configurator setting		
Initial setting	△	Section 5.2.1(4)
Auto refresh setting	△	Section 5.2.1(4)

●: Always set, ▲: Default setting, △: Set as needed, ×: No need to set

* 4 : Refer to the User's Manual (Function Explanation, Program Fundamentals) for the CPU module used.

* 5 : Refer to the Q Corresponding Ethernet Interface Module User's Manual (Basic) (SH-080009). Note that interrupt setting is not available.

* 6 : Refer to the MELSEC-Q CC-Link System Master/Local Module User's Manual (SH-080394E). Note that interrupt setting is not available.

2.3.3 Available device ranges

The remote I/O network can use the following device ranges in the network module.

Device	Available range	Others
LB	0 _H to 3FFF _H (16384 points)	The device range (excluding that of I/O module mounted on the host station) should be assigned to each network module.
LW	0 _H to 3FFF _H (16384 points)	
LX	0 _H to 1FFF _H (8192 points)	
LY	0 _H to 1FFF _H (8192 points)	

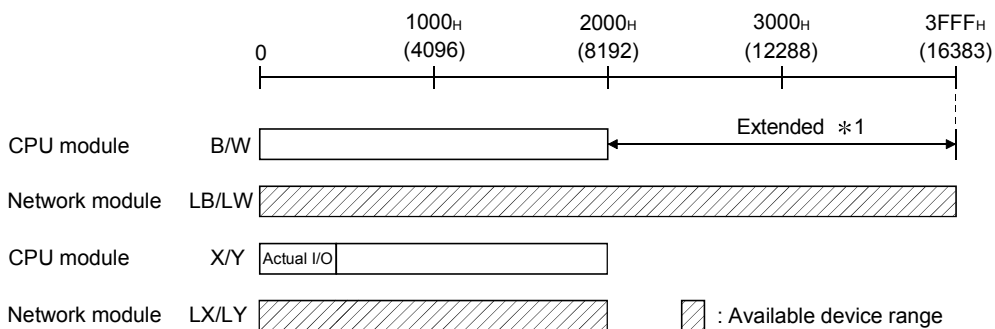

* 1: Expandable by changing from [PLC parameters] - [Device settings]

2.4 Multiple Remote I/O Network

2.4.1 Configuration

A multiple remote I/O network system is a network system with many networks connected to it.

Set a unique number. The numbers can be set within a range from 1 to 239.

Up to four master modules can be mounted on the remote master station.

Note that, however, there are restrictions on the number of master modules that can be mounted, depending on the CPU module used. (Refer to Section 2.5.)

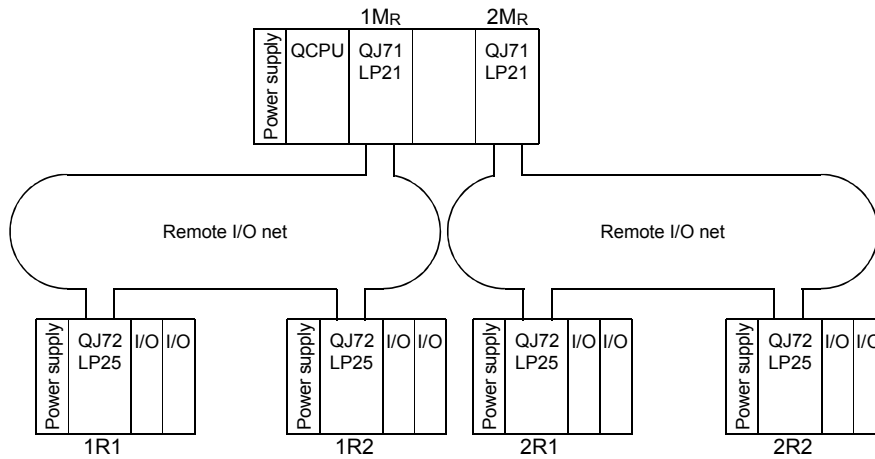

2.4.2 Setting items

- (1) Table 2.7 lists the setting items for the master module main module for a remote master station (MR) and the parameter settings from the GX Developer.

Table 2.7 Remote master station setting items

Setting items	Remote master station (MR)	Reference
Network module main module switch		
STATION NO.	0	Section 4.2.1
MODE	●	Section 4.2.1
Parameter setting on GX Developer		
Setting the number of Ethernet/CC IE/MELSECNET cards		
Network type	MELSECNET/H (Remote master station)	Section 5.1.1
Starting I/O No.	●	Section 5.1.2
Network No.	●	Section 5.1.2
Total number of remote modules	●	Section 5.1.2
Group No.	×	—
Mode	●	Section 5.1.2
Common parameters	●	Section 5.1.3
Supplementary setting	△	Section 5.1.4
Station specific parameters	×	—
Refresh parameters	● * 1 * 2	Section 5.1.5
Valid module during other station access	△	Section 5.1.6
Inter-link data transfer parameters	×	—
Routing parameters	△	* 3

●: Always set, ▲: Default setting, △: Set as needed, ×: No need to set

* 1: Default values are not set in LX/LY. Set the refresh parameters.

* 2: Default values are preset for LB/LW.

The CPUs other than the Universal model QCPU may operate even if refresh parameters have not been set.

For the operation and precautions, refer to Section 5.1.5 (3).

* 3: Refer to the Q Corresponding MELSECNET/H Network System Reference Manual (PLC to PLC Network) (SH-080049).

(2) Table 2.8 lists the setting items for the remote I/O module main module for the remote I/O station (R) and the parameter setting items from the GX Developer.

Table 2.8 Remote I/O station setting items

Setting items	Remote I/O station (R)	Reference
Network module main module switch		
STATION NO.	1 to 64	Section 4.2.2
MODE	●	Section 4.2.2
GX Developer parameter setting		
PLC system	▲	* 4
PLC RAS	▲	* 4
I/O assignment	△	* 4
Operation setting	△	Section 5.2.1
Ethernet setting	△	* 5
CC-Link setting	△	* 6
Remote password setting	△	Section 7.12
GX Configurator setting		
Initial setting	△	Section 5.2.1(4)
Auto refresh setting	△	Section 5.2.1(4)

●: Always set, ▲: Default setting, △: Set as needed, ×: No need to set

*4 : Refer to the User's Manual (Function Explanation, Program Fundamentals) for the CPU module used.

*5 : Refer to the Q Corresponding Ethernet Interface Module User's Manual (Basic) (SH-080009). Note that the interrupt setting is not available.

*6 : Refer to the MELSEC-Q CC-Link System Master/Local Module User's Manual (SH-080394E). Note that the interrupt setting is not available.

2.4.3 Available device ranges

The remote I/O network can use the following device ranges in the network module.

Device	Available range	Others
LB	0 _H to 3FFF _H (16384 points)	The device range (excluding that of I/O module mounted on the host station) should be assigned to each network module.
LW	0 _H to 3FFF _H (16384 points)	
LX	0 _H to 1FFF _H (8192 points)	
LY	0 _H to 1FFF _H (8192 points)	

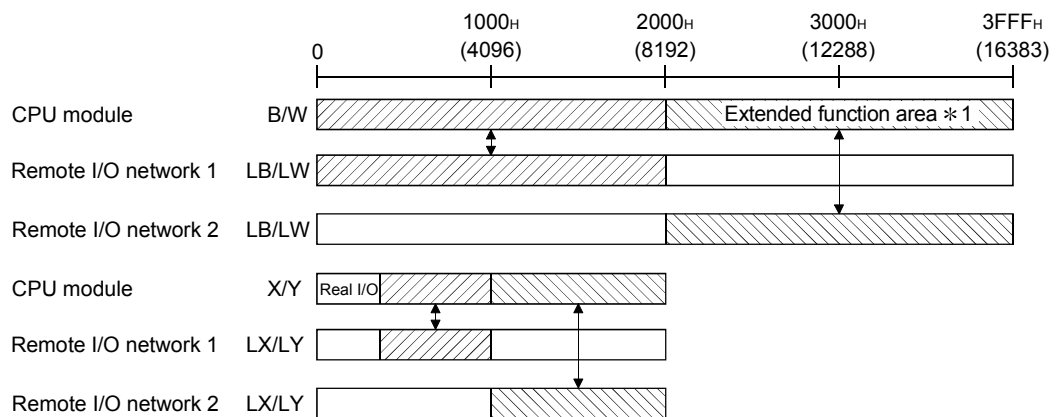

*1: Expandable by changing from [PLC parameters] - [Device settings]

2.5 Applicable Systems

2.5.1 Applicable systems for remote master stations

This section describes applicable systems of remote master stations.

No. of mountable modules is the maximum number of mountable network modules with CC-Link IE Controller Network.

(1) Applicable modules and base units, and No. of modules

(a) Mounting with a CPU module

For the CPU modules and base units applicable to the master module and the number of mountable master modules, refer to the following.

- User's manual for the CPU module used.

Depending on the combination with other modules or the number of mounted modules, power supply capacity may be insufficient.

Pay attention to the power supply capacity before mounting modules, and if the power supply capacity is insufficient, change the combination of the modules.

(b) Mounting to a MELSECNET/H remote I/O station

The master module cannot be mounted to any MELSECNET/H remote I/O station.

Mount it to a CPU module on a master station.

(2) Support of the multiple CPU system

When using the network module in a multiple CPU system, refer to the QCPU User's Manual (Multiple CPU System) first.

To construct the remote I/O network with a multiple CPU system, use a master module of function version B or later.

For precautions for the use in a multiple CPU system, refer to Section 2.6.

(3) Network type

The available network type varies depending on the CPU module type, the function version of the master module, and the version of GX Developer/GX Works2.

Network type	CPU module	Master module	GX Developer	GX Works2
Multiplexed remote I/O network for redundant system	Q12PRHCPU, Q25PRHCPU	Function version D or later	Version 8.18U or later	
Multiple remote I/O network	Q02PHCPU, Q06PHCPU	Function version B or later (Serial No. (first five digits) "04012" or later)	Version 8.68W or later	Version 1.87R or later
	Q12PHCPU, Q25PHCPU	Function version B or later (Serial No. (first five digits) "04012" or later)	Version 7.10L or later	
Remote I/O network	Q02CPU, Q02HCPU, Q06HCPU, Q12HCPU, Q25HCPU, Q12PHCPU, Q25PHCPU	Function version B or later	Version 6 or later	Version 1.40S or later
	Q00UJCPU, Q00UCPU, Q01UCPU	Function version B or later	Version 8.76E or later	
	Q02UCPU, Q03UDCPU, Q04UDHCPU, Q06UDHCPU	Function version B or later	Version 8.48A or later	
	Q10UDHCPU, Q20UDHCPU	Function version B or later	Version 8.76E or later	
	Q13UDHCPU, Q26UDHCPU	Function version B or later	Version 8.62Q or later	
	Q03UDECPU, Q04UDEHCPU, Q06UDEHCPU, Q13UDEHCPU, Q26UDEHCPU	Function version B or later	Version 8.68W or later	
	Q10UDEHCPU, Q20UDEHCPU	Function version B or later	Version 8.76E or later	
	Q50UDEHCPU, Q100UDEHCPU	Function version B or later	Not supported	
	Q03UDVCPU, Q04UDVCPU, Q06UDVCPU, Q13UDVCPU, Q26UDVCPU	Function version B or later	Not supported	Version 1.95Z or later

2.5.2 Applicable systems for remote I/O stations

This section explains application systems of remote I/O stations.
Mount a remote I/O module to a CPU slot of any of the main base units.

(1) Applicable main base units, power supply modules and No. of modules

Main base unit* ¹	Power supply module	Number of mountable remote I/O modules* ²
Q33B, Q35B, Q38B, Q312B	Q6□P	1 (mounted in the CPU slot)
Q35BL, Q38BL (Q series large type main base unit)	Q6□P	
Q35BLS, Q35BLS-D, Q38BLS, Q38BLS-D (AnS size Q series large type main base unit)	Q6□P	
Q32SB, Q33SB, Q35SB (Slim type main base unit)	Q61SP	
Q35DB, Q38DB, Q312DB (Multiple CPU high-speed main base unit)	Q6□P	
Q38RB (Main base unit for the redundant power supply system)	Q63RP, Q64RP	

*1: Total of up to 64 modules can be mounted to a base unit. Mount a module within the number of I/O points for the remote I/O module. If the number of slots is within the available range, the module can be mounted on any slot.

*2: Depending on the combination with other modules or the number of mounted modules, power supply capacity may be insufficient. Pay attention to the power supply capacity before mounting modules, and if the power supply capacity is insufficient, change the combination of the modules.

(2) Applicable extension base units

A system with a remote I/O module can be connected with extension base units.

Extension base unit	Extension cable model ^{*2} (Maximum distance: 13.2m or less)	Number of extension base units
Q63B, Q65B, Q68B, Q612B (Extension base unit (type requiring power supply module))	QC05B, QC06B, QC12B, QC30B, QC50B, QC100B	Up to 7
Q53B, Q55B (Extension base unit (type requiring no power supply module)) ^{*1}		
Q65BL, Q68BL (Q series large type extension base unit (type requiring power supply module))		
Q55BL (Q series large type extension base unit (type requiring no power supply module)) ^{*1}		
Q65BLS, Q65BLS-D, Q68BLS, Q68BLS-D (AnS size Q series large type extension base unit (type requiring power supply module))		
Q55BLS, Q55BLS-D (AnS size Q series large type extension base unit (type requiring no power supply module)) ^{*1}		
Q68RB (Extension base unit for redundant power supply system)		

- *1: When using an extension base unit (type requiring no power supply module), calculate the operating voltage of the unit to check that it is within the specified range.
 - 1) For the calculation method, refer to the QCPU User's Manual (Hardware Design, Maintenance and Inspection).
 - 2) For the current consumption of modules mounted on the base unit, refer to the manual of the corresponding module.
- *2: Note the following points when using extension cables.
 - 1) Do not install extension cables together with the main circuit (high voltage, large current) cables.
 - 2) Connect an extension cable from the OUT of the extension cable connector of the base unit to the IN of the next extension base unit.

(3) Network type

The available network type varies depending on the function version of the remote module and the version of GX Developer.

Network type	Remote I/O module	GX Developer	GX Works2
Multiplexed remote I/O network for redundant system	Function version D or later	Version 6 or later	Version 1.87R or later
Multiple remote I/O network	Function version B or later		Version 1.40S or later
Remote I/O network			

(4) Applicable modules

The Q series modules can be used on remote I/O stations.

Note that some modules have restrictions.

(a) Functional restrictions

The use of interrupt pointers and dedicated instructions for intelligent function modules are not supported.

For the restrictions of functions for each module, refer to the user's manual for the module used.

(b) No. of mountable modules

Module Name	No. of mountable modules
QJ71E71-B5, QJ71E71-B2, QJ71E71-100, QJ71E71	Up to 4 *1
QJ61BT11N, QJ61BT11	Up to 4
Modules other than those listed above	Up to 64

*1: The module with function version B or later is available.

(5) Units/modules not applicable

The following units/modules cannot be used on remote I/O stations.

Item	Module model name
Redundant type extension base unit	Q65WRB
AnS series extension base unit	QA1S65B, QA1S68B, QA65B, QA68B
CC-Link IE Controller Network module	QJ71GP21-SX, QJ71GP21S-SX
CC-Link IE Field Network master/local module	QJ71GF11-T2
MELSECNET/H module	QJ71LP21, QJ71LP21-25, QJ71LP21S-25, QJ71LP21G, QJ71BR11, QJ71NT11B
Web server module	QJ71WS96
MES interface module	QJ71MES96
AS-i master module	QJ71AS92
High speed data logger module	QD81DL96
High speed data communication module	QJ71DC96
Interrupt module	QI60, QX40H*1, QX70H*1, QX80H*1, QX90H*1

*1: These modules cannot be used when switched to interrupt modules by turning off the function selecting switch (SW2).

(6) ERR. contact of the power supply module

The operation of the ERR. contact of the power supply module differs depending on the combination with the base unit used. For the operation of the ERR. contact, refer to the QCPU User's Manual (Hardware Design, Maintenance and Inspection).

(7) Online module change

In the following cases, the online module change cannot be performed.

- (a) When an extension base unit (type requiring no power supply module) (Q52B, Q55B, Q55BL, Q55BLS, or Q55BLS-D) is used (No module mounted on any extension base unit can be changed online.)
- (b) When a slim type power supply module (Q61SP) is used

(8) MELSECNET/10 mode

The MELSECNET/10 mode can be set with the remote I/O module whose serial No. (first five digits) is "15012" or later.

(9) Precautions for mounting an intelligent function module

Note that the number of intelligent function module parameters that may be set (initial setting, automatic refresh setting) is limited on the remote I/O module.

If the number of parameters set exceeds the limited number, the remote I/O module detects the "SP. PARA ERROR (3301)" error.

To auto refresh the excessive parameters, use the REMFR/REMTO instruction to read/write data from/to the intelligent function module.

Item	No. of the parameters that can be set
Initial setting	Up to 512
Auto refresh setting	Up to 256

The number of parameters for initial setting is fixed for each intelligent function module. To check the numbers of parameters for initial setting, refer to the user's manuals for the corresponding intelligent function modules.

For the way to count the number of parameters for automatic refresh setting, refer to Section 5.2.1 (4).

2.6 When Using a Multiple CPU System

Take the following points into consideration when configuring a remote I/O network by utilizing multiple CPU system.

- (1) Use the master module of function version B or later.
- (2) Set the network parameters to the control CPU controlling the master module.
- (3) It is possible to set up to four master modules per control CPU. Note that the maximum number of mountable master modules per multiple CPU system is four.

(a) CPU No. 1 controls all master modules

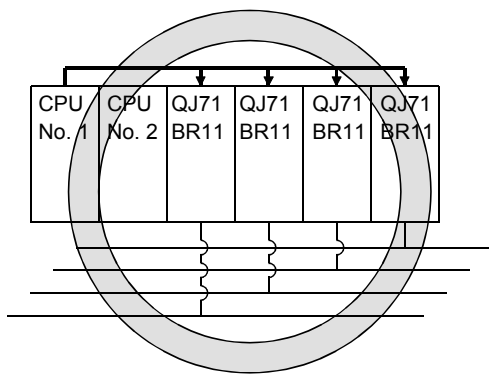

(b) CPU No. 1 and CPU No. 2 control each master module

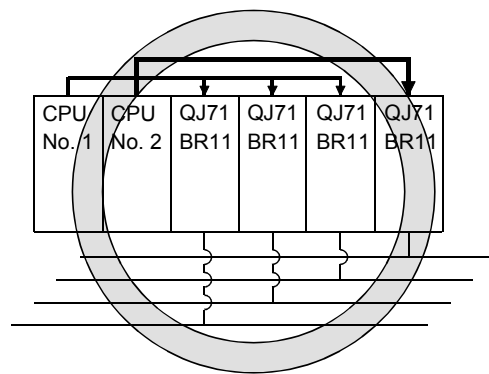

(c) CPU No 1 to No. 4 control each master module

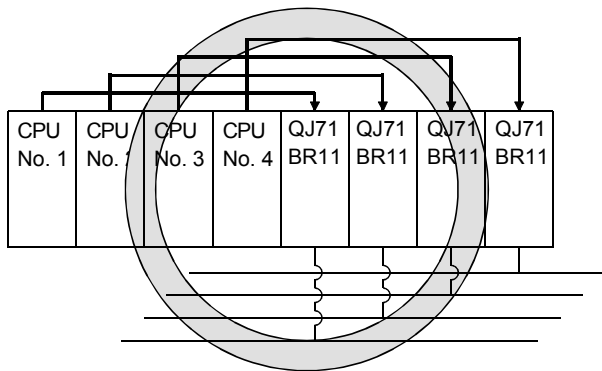

(d) The maximum number of mountable master modules per system is four

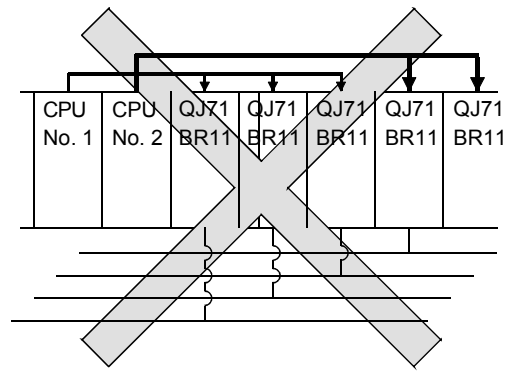

* : The number of mounted modules exceeds the limit by one.

- (4) By connecting to a remote I/O station for access to other stations, GX Developer can access stations in the other network system, whether the relay stations in the multiple CPU system are controlled by the same or different CPUs. Also, GX Developer can access either the control CPU or non-control CPU in the multiple CPU system.

(a) Accessible to the remote I/O stations in another network

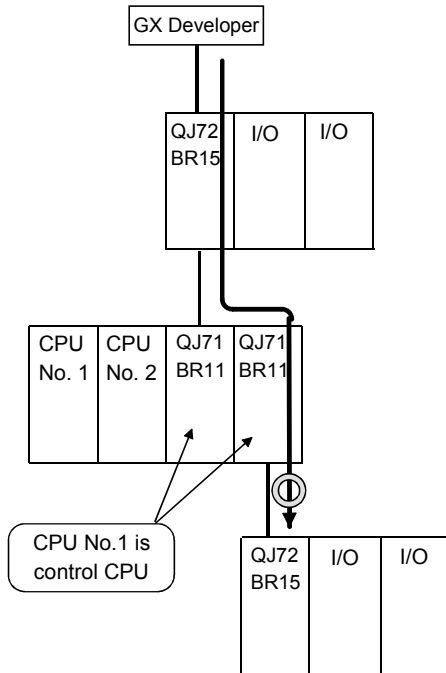

(b) Accessible to the control CPU in another network

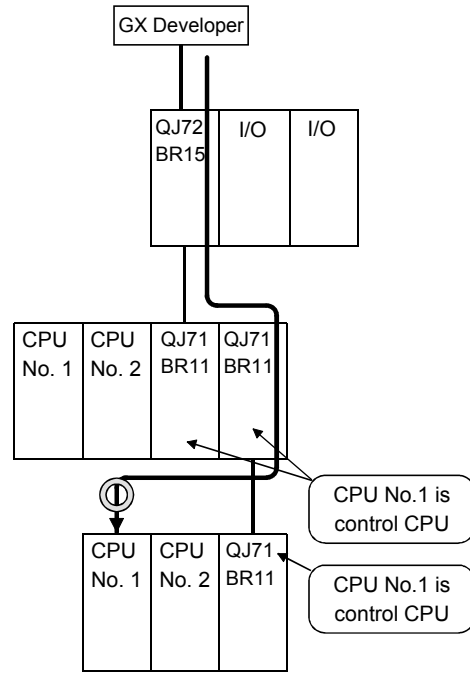

(c) Accessible to the non-control CPUs in another network

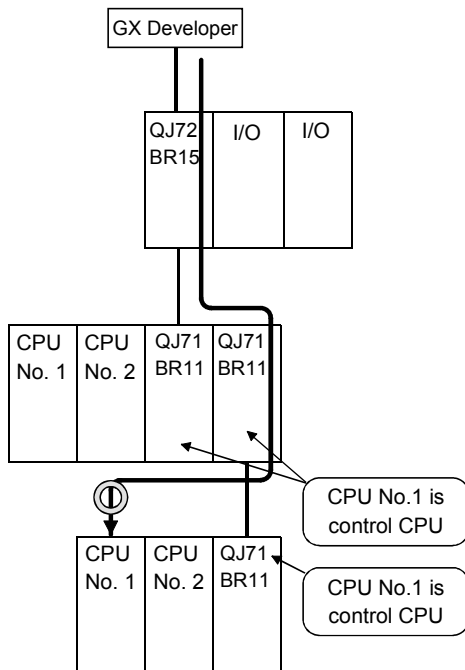

(d) Accessible to another network even if the relayed station is controlled by another control CPU

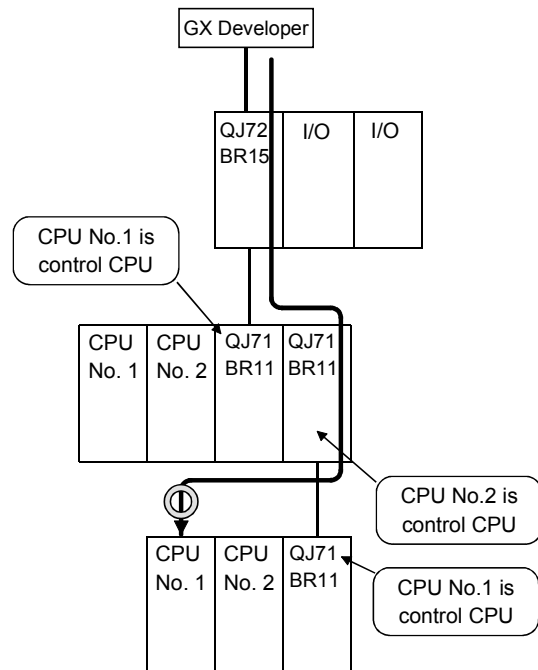

- (5) When all of the following conditions from a) to d) are met, use a MELSECNET/H module whose serial No. (first five digits) is "10042" or later.
 - (a) A multiple CPU system containing a Built-in Ethernet port QCPU is configured.
 - (b) To the Ethernet port of the Built-in Ethernet port QCPU, GX Developer or GOT is connected.
 - (c) From GX Developer or GOT, access is made to another station through a MELSECNET/H module controlled by another CPU.
 - (d) The access target on another station is an A/QnA series CPU module.

2.7 Checking Function Version and Serial No.

The serial No. and function version of the network module can be confirmed on the rating plate and GX Developer's system monitor.

(1) Checking the serial No. on the rating plate

The rating plate is situated on the side face of the network module.

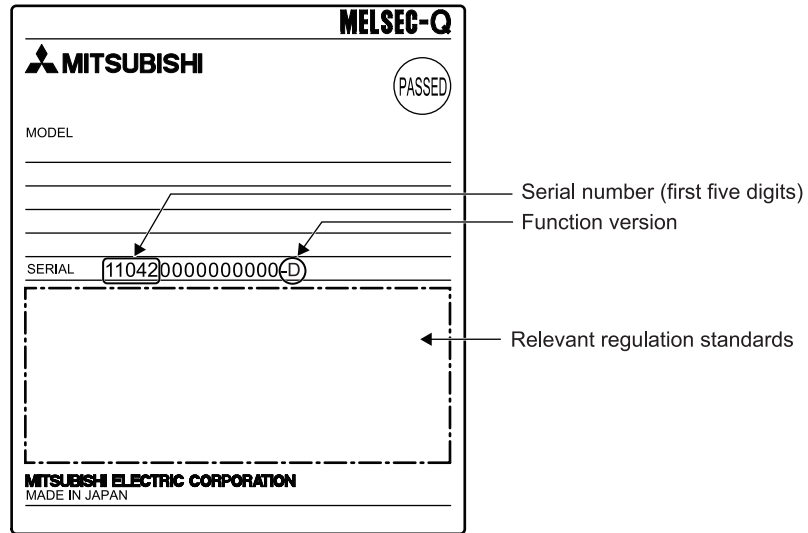

(2) Checking on the front of the module

The serial No. and function version on the rating plate are also indicated on the front of the module (lower part).

The following network module is not included.

- QJ71LP21

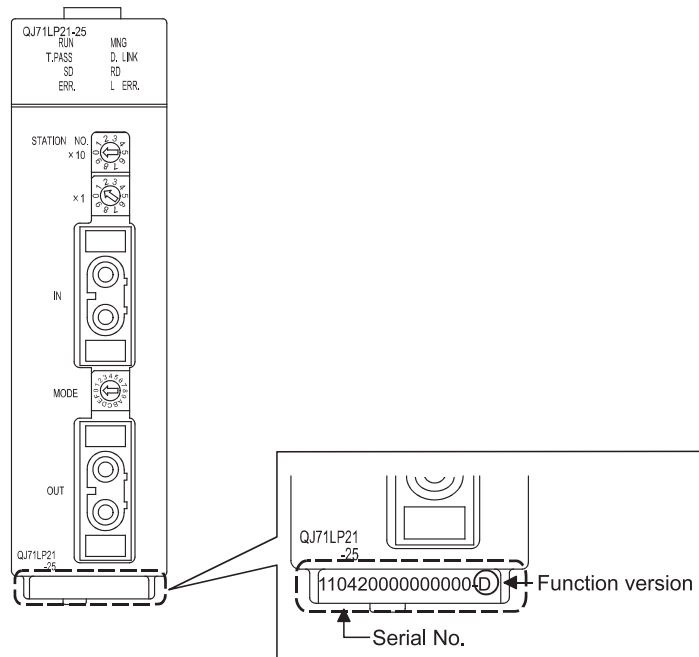

(3) Checking the serial No. on the system monitor (Product Information List)

To display the system monitor, select [Diagnostics] → [System monitor] → [Product Inf. List] button of GX Developer.

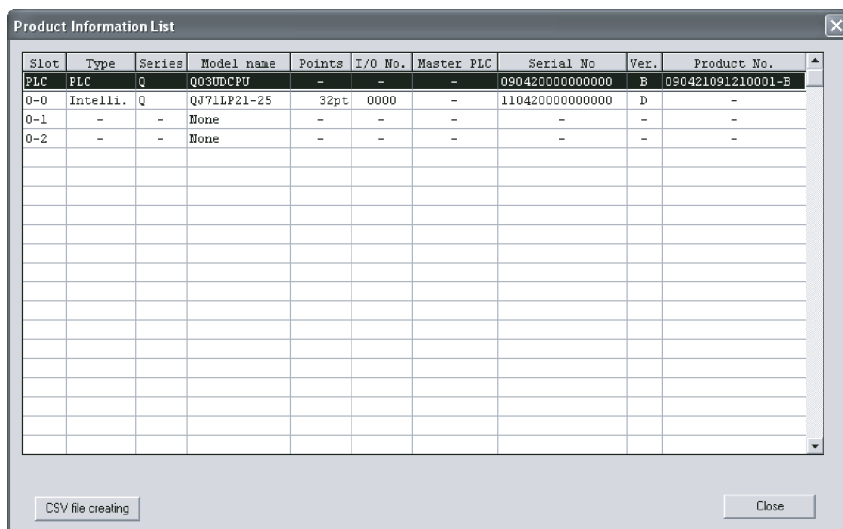

(a) Production number display

Since the network module does not support the production number display, "-" is displayed.

POINT
<p>The serial No. displayed in the Product Information List of GX Developer may be different from the one on the rating plate and the front of the module.</p> <ul style="list-style-type: none"> • The serial No. on the rating plate and the front of the module indicates the management information of the product. • The serial No. in the Product Information List of GX Developer indicates the functional information on the product, which is updated when a new function is added.

3 SPECIFICATIONS

The following describes the network system specifications, performance specifications and the specifications for sending and receiving link data.
 For general specifications, refer to the user's manual of the CPU module to be used on the network system.

3.1 Performance Specifications

3.1.1 Optical loop system performance specifications

Table 3.1 lists the performance of the optical loop system.

Table 3.1 Optical loop system performance specifications

Item	Remote master station				Remote I/O station				
	QJ71LP21	QJ71LP21G	QJ71LP21GE	QJ71LP21-25	QJ71LP21S-25	QJ72LP25-25	QJ72LP25G	QJ72LP25GE	
Maximum number of links per network	LX/LY	8192 points							
	LB	16384 points (Remote master station → remote sub-master station, remote I/O station: 8192 points, remote sub-master station, remote I/O station → remote master station: 8192 points)							
	LW	16384 points (Remote master station → remote sub-master station, remote I/O station: 8192 points, remote sub-master station, remote I/O station → remote master station: 8192 points)							
Maximum number of links per station	<ul style="list-style-type: none"> Remote Master Station → Remote I/O station $((LY + LB)/8 + (2 \times LW)) \leq 1600$ bytes *1 Remote I/O station → Remote Master Station $((LX + LB)/8 + (2 \times LW)) \leq 1600$ bytes Multiplexed remote master station ↔ multiplexed remote sub-master station $((LY + LB)/8 + (2 \times LW)) \leq 2000$ bytes 								
Maximum I/O points per remote I/O station	$X + Y \leq 4096$ points If the X/Y numbers are the same, only one side is taken into consideration.								
Device points per remote I/O station	M	8192 points							
	SM	2048 points							
	D	12288 points							
	SD	2048 points							
Communication speed	10 Mbps		25 Mbps / 10 Mbps / (selected with MODE switch)			10 Mbps			
Number of stations per network	65 stations (Remote master stations: 1 Remote I/O stations: 64) *2								
Overall distance	30 km								
Distance between stations *3	25 Mbps	—				SI optical cable : 200m H-PCF optical cable : 400m Broad-band H-PCF optical cable : 1km QSI optical cable : 1km		—	
	10 Mbps	SI optical cable : 500m H-PCF optical cable : 1km Broad-band H-PCF optical cable : 1km QSI optical cable : 1km	GI-50/125 optical cable : 2km	GI-62.5/125 optical cable : 2km	SI optical cable : 500m H-PCF optical cable : 1km Broad-band H-PCF optical cable : 1km QSI optical cable : 1km	GI-50/125 optical cable : 2km	GI-62.5/125 optical cable : 2km		
Network cable	Optical fiber cable (procured by a user) *3								
Applicable connectors	2-core optical connector plug (procured by a user)								
Maximum number of networks	239 (Total including PLC to PLC networks)								
Transmission path format	Duplex loop								
Communication method	Token ring								
Synchronization method	Frame synchronization								
Coding method	NRZI code (Non Return to Zero Inverted)								
Transmission format	HDCL standards (Frame format)								
Error control	CRC ($X^{16} + X^{12} + X^5 + 1$) and retry by timeout								
RAS functions	<ul style="list-style-type: none"> Loop-back function due to error detection or broken cable Diagnostic function for checking local link lines Detection using link special relays or link special registers Backup of power supply on a remote I/O station Online module change in a remote I/O station 								
Application function	<ul style="list-style-type: none"> Remote password for remote I/O station 								
Transient transmission	<ul style="list-style-type: none"> 1:1 communication (Monitor, program upload/download, etc.) Various send/receive commands from the programmable controller program (READ/WRITE, REMFR/REMTO) 								



Item		Remote master station				Remote I/O station			
		QJ71LP21	QJ71LP21G	QJ71LP21GE	QJ71LP21-25	QJ71LP21S-25	QJ72LP25-25	QJ72LP25G	QJ72LP25GE
Number of occupied I/O points		32 points (Intelligent function module: 32 points)				48 points (I/O Assignment: empty; first 16, intelli.: second 32) * 4	—		
External Power Supply	Voltage	—				20.4 to 31.2 V DC	—		
	Current	—				0.20 A	—		
	Size of terminal screw	—				M3 Screw	—		
	Suitable crimp terminal	—				R1.25-3	—		
	Suitable cable size	—				0.3 to 1.25 mm ²	—		
	Tightening torque	—				0.42 to 0.58 N•m	—		
	Allowable momentary power failure time	—				1ms (Level PS1)	—		
	Noise immunity	—				By noise simulator of 500Vp-p noise voltage, 1ms noise width, and 25 to 60Hz noise frequency	—		
5 V DC internal current consumption		0.55 A				0.89 A			
External dimensions		98 (H) × 27.4 (W) × 90 (D) [mm]				98 (H) × 55.2 (W) × 90 (D) [mm]	98 (H) × 27.4 (W) × 90 (D) [mm]		
Weight		0.11 kg				0.20 kg	0.15 kg		

- * 1: The remote master station includes the multiplexed remote master station and multiplexed remote sub-master station.
- * 2: On a multiplexed remote I/O network, one of 64 remote I/O stations works as a multiplexed remote sub-master station.
- * 3: The optical fiber cable (A-2P- □) differs in interstation distance between the L and H types. Refer to Section 4.8.1 for details.
- * 4: Two slots are occupied.
Set the numeric value resulted from adding 10H to the I/O No. of the slot where a module mounted as the "Starting I/O No." of the "Network parameter". The first empty 16 points can be set to "0" on the "I/O assignment" tab screen within the "Q Parameter" screen.
Example: Set 10H as the "Starting I/O No." when the module is mounted on slot 0.
(Set 0H as the "Starting I/O No." when 0 has been set to slot 0 on the "I/O assignment" tab screen.)

3.1.2 Coaxial cable system performance specifications

Table 3.2 lists the performance of the coaxial bus system.

Table 3.2 Coaxial cable system performance specifications

Item		Remote master station	Remote I/O station
		QJ71BR11	QJ72BR15
Maximum number of links per network	LX/LY	8192 points	
	LB	16384 points (Remote master station → remote sub-master station, remote I/O station: 8192 points, remote sub-master station, remote I/O station → remote master station: 8192 points)	
	LW	16384 points (Remote master station → remote sub-master station, remote I/O station: 8192 points, remote sub-master station, remote I/O station → remote master station: 8192 points)	
Maximum number of links per station	<ul style="list-style-type: none"> Remote Master Station → Remote I/O station $((LY + LB)/8 + (2 \times LW)) \leq 1600$ bytes * 1 Remote I/O station → Remote Master Station $((LX + LB)/8 + (2 \times LW)) \leq 1600$ bytes Multiplexed remote master station ↔ multiplexed remote sub-master station $((LY + LB)/8 + (2 \times LW)) \leq 2000$ bytes 		
Maximum I/O points per remote I/O station	$X + Y \leq 4096$ points If the X/Y numbers are the same, only one side is taken into consideration.		
Device points per remote I/O station	M	8192 points	
	SM	2048 points	
	D	12288 points	
	SD	2048 points	
Communication speed	10 Mbps		
Number of stations per network	33 stations (Remote master stations: 1 Remote I/O stations: 32) * 2		
Overall distance	3C-2V	300 m (Between stations 300 m) * 3	
	5C-2V	500m (Between stations 500 m) * 3	
	5C-FB	500m (Between stations 500 m) * 3	
	Can be extended up to 2.5 km with the use of a repeater (A6BR10,A6BR10-DC)		
Maximum number of networks	239 (Total including PLC to PLC networks)		
Transmission path format	Single layer bus		
Communication method	Token bus		
Synchronization method	Frame synchronization		
Coding method	Manchester code		
Transmission format	HDCL standards (Frame format)		
Error control	CRC ($X^{16} + X^{12} + X^5 + 1$) and retry by timeover		
RAS functions	<ul style="list-style-type: none"> Station separation function due to error detection or cable disconnection Diagnostic function for checking local link lines Detection using link special relays or link special registers Configuring a redundant power supply on a remote I/O station Online module change in a remote I/O station 		
Application function	<ul style="list-style-type: none"> Remote password for remote I/O station 		
Transient transmission	<ul style="list-style-type: none"> 1:1 communication (Monitor, program upload/download, etc.) Various send/receive commands from the programmable controller program (READ/WRITE,REMFR/REMTO) 		
Maximum number of modules per CPU	4 modules	—	
Number of I/O points	32 points (Intelligent function module: 32 points)	—	
5 V DC internal current consumption	0.75 A	1.10 A	
External dimensions	98 (H) × 27.4 (W) × 90 (D) [mm]		
Weight	0.11 kg	0.16 kg	

* 1: The remote master station includes the multiplexed remote master station and multiplexed remote sub-master station.

* 2: On a multiplexed remote I/O network, one of 32 remote I/O stations works as a multiplexed remote sub-master station.

* 3: There are restrictions on the interstation cable length depending on the number of connected stations. Refer to Section 4.8.2 for details.

3.1.3 Optical fiber cable specifications

This section explains the specifications of the optical fiber cables used with the MELSECNET/H optical loop system. Confirm that the cable in use conforms to the details of the optical fiber cable specifications.

A technical skill and a special tool are needed when connecting an optical fiber cable to an exclusive connector.

Optical fiber cables with connectors are also available.

For cabling, please consult your local Mitsubishi representative.

Table 3.3 Optical fiber cable specifications

Item		SI (Multi-particulate glass)	H-PCF (Plastic-clad)	Broad-band H-PCF (Plastic-clad)	QSI (Quartz glass)	QI-50/125 (Quartz glass)	QI-62.5/125 (Quartz glass)
Interstation distance	10 Mbps	500 m	1 km	1 km	1 km	2 km	2 km
	25 Mbps	200 m	400 m	1 km	1 km	Must not be used	Must not be used
Transmission loss		12 dB/km	6 dB/km	5 dB/km	5.5 dB/km	3 dB/km	3 dB/km
Core diameter		200 μm	200 μm	200 μm	185 μm	50 μm	62.5 μm
Clad diameter		220 μm	250 μm	250 μm	230 μm	125 μm	125 μm
Primary membrane		250 μm	—	—	250 μm	—	—
Applicable connector		F06/F08 or equivalent (JIS C5975/5977 conformance)					

REMARKS

The following types of optical fiber cables are available.

A type: Cable for connection inside control panel

B type: Cable for connection between control panels inside a building

C type: Cable for outdoor connection

D type: Reinforced cable for outdoor connection

For other special-purpose cables such as flexible cables or heat-resistant cables, please contact your local Mitsubishi representative.

(1) Cable loss of GI-62.5/125 optical fiber cable

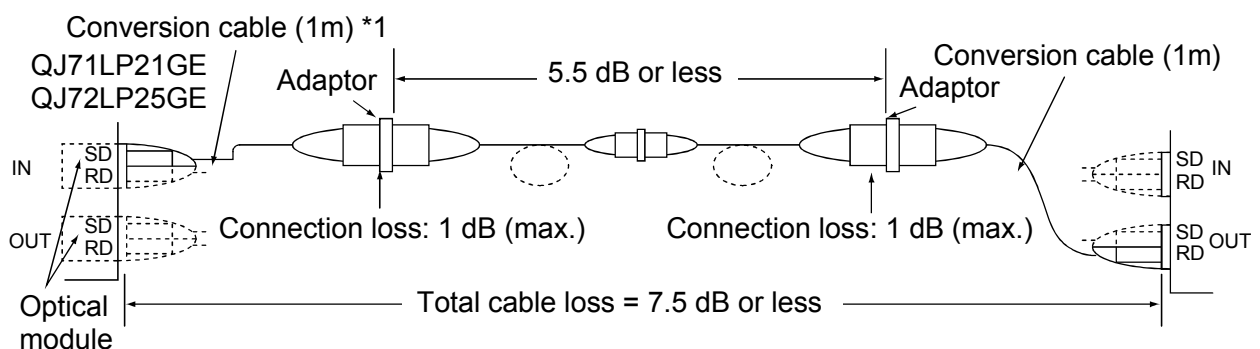

*1: Conversion cable

Conversion Type	Cable
CA type ↔ FC type	AGE-1P-CA/FC1.5M-A
CA type ↔ ST type	AGE-1P-CA/ST1.5M-A
CA type ↔ SMA type	AGE-1P-CA/SMA1.5M-A

Purchased from: Mitsubishi Electric Europe GmbH

3.1.4 Coaxial cable specifications

The following table lists the specifications of the coaxial cables used for the coaxial bus system.

Use the following high frequency coaxial cables:

- 3C-2V (JIS C 3501 compliant)
- 5C-2V (JIS C 3501 compliant)
- 5C-FB (JIS C 3502 compliant)

However, when configuring a multiplexed remote I/O network for redundant system, use a double shield coaxial cable. (Refer to section 4.8.2.)

(1) Coaxial cable specifications

The specifications of the coaxial cable are shown in Table 3.4.

Select coaxial cables that meet the operating ambient temperature (0 to 55°C) listed in the general specifications of the programmable controller.

Table 3.4 Coaxial cable specifications

Item	3C-2V	5C-2V	5C-FB
Structure			
Cable diameter	5.4 mm	7.4 mm	7.7mm
Minimum allowable bend radius	23 mm or more	30 mm or more	30 mm or more
Internal conductor diameter	0.5 mm (annealed copper wire)	0.8 mm (annealed copper wire)	1.05mm (annealed copper wire)
Insulating material diameter	3.1 mm (polyethylene)	4.9 mm (polyethylene)	5.0mm (polyethylene)
External conductor diameter	3.8 mm (single annealed copper wire mesh)	6.6 mm (single annealed copper wire mesh)	5.7mm (aluminum foil tape and annealed copper wire mesh)
Applicable connector plug	3C-2V connector plug The following connector plugs are recommended: • BNC-P-3-NiCAu ^{*1} (Manufactured by DDK Ltd.) • BCP-C3B ^{*2} (Manufactured by Canare Electric Co., Ltd.)	5C-2V connector plug The following connector plugs are recommended: • BNC-P-5-NiCAu ^{*1} (Manufactured by DDK Ltd.) • BCP-C5B ^{*2} (Manufactured by Canare Electric Co., Ltd.)	5C-FB connector plug BCP-C5FA ^{*2} (manufactured by Canare Electric Co., Ltd.) is recommended.

* 1: This connector plug is a soldering-type connector plug.

* 2: This connector plug is a crimping-type connector plug.

REMARKS

To order or for inquiries regarding connector plugs and coaxial cables, please consult your local Mitsubishi representative.

(2) Connecting the coaxial cable connectors

The following section explains how to connect the BNC connector (the connector plug for the coaxial cable) to the cable.

(a) Using a BNC connector manufactured by DDK Ltd.

The following explains how to connect the BNC-P-3-NiCAu or BNC-P-5-NiCAu to the cable.

	<p>CAUTION</p> <ul style="list-style-type: none"> Solder the coaxial cable connectors properly. Insufficient soldering may result in malfunctions.
---	--

• Structure of the BNC connector and coaxial cable

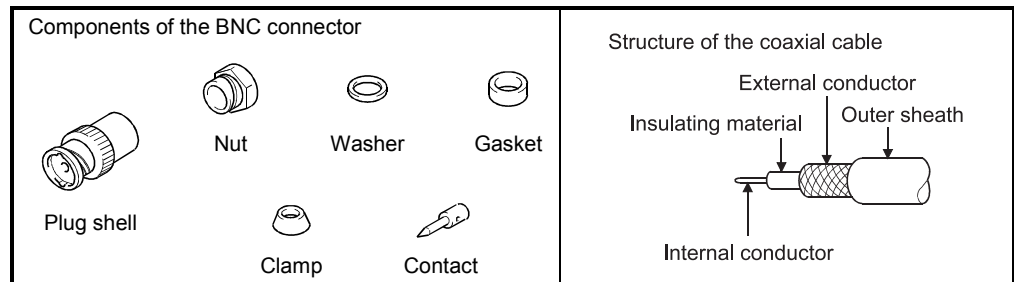

• How to connect the BNC connector and the coaxial cable

1) Cut the portion of the outer sheath of the coaxial cable as shown in the diagram below.

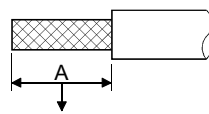

Cut this portion of the outer sheath

Applicable cable	A
3C-2V	15mm
5C-2V, 5C-2V-CCY	10mm

2) Fit the nut, washer, gasket and clamp onto the coaxial cable, as shown below, and then loosen the external conductor.

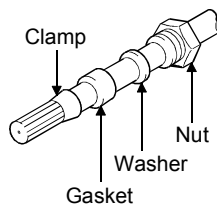

3) Cut the external conductor, insulating material and internal conductor to the dimensions shown below. Note that the external conductor should be cut to the same dimension as the tapered section of the clamp and smoothed down to the clamp.

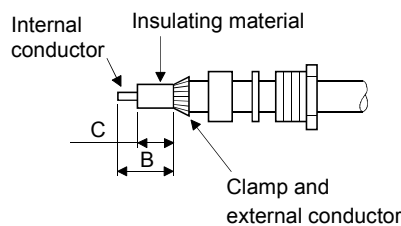

Applicable cable	B	C
3C-2V	6mm	3mm
5C-2V, 5C-2V-CCY	7mm	5mm

- 4) Solder the contact to the internal conductor.

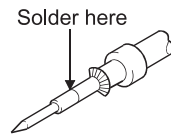

- 5) Insert the connector assembly shown in 4) into the plug shell and screw the nut into the plug shell.

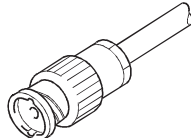

POINT
(1) The following precautions should be observed when soldering the internal conductor and contact: <ul style="list-style-type: none">• Make sure that the solder does not bead up at the soldered section.• Make sure that there are no gaps between the connector and cable insulating material and that they do not cut into each other.• Solder as quick as possible so the insulating material does not deform.
(2) Before connecting or disconnecting the coaxial connector, touch a grounded metal object to discharge the static electricity from the human body. Failure to do so may result in a module malfunction.

- (b) Using a BNC connector manufactured by Canare Electric Co., Ltd.
The following explains how to connect the BCP-C3B, BCP-C5B, or BCP-C5FA to the cable.

• Structure of the BNC connector and coaxial cable

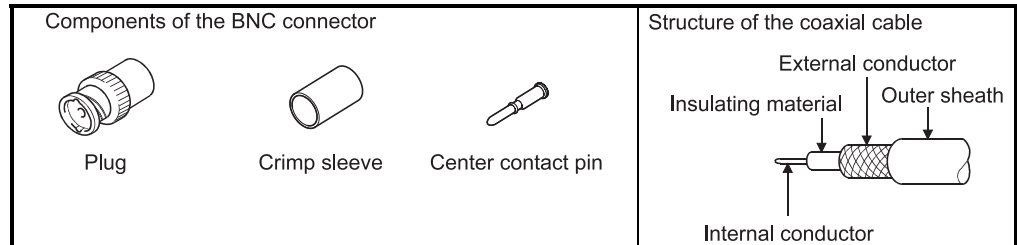

• How to connect the BNC connector and the coaxial cable

- 1) Thread a coaxial cable through a crimping sleeve as shown in the figure below.

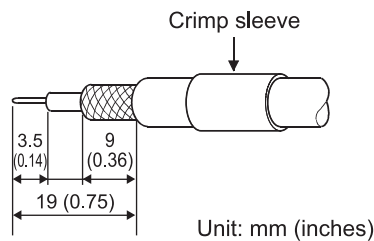

When using a cable with aluminum tape, cut the tape as shown in the figure below.

When cutting the tape, make a clean cut, without leaving any stray pieces or loose strands. Failure to do so may cause a short circuit or result in an improper crimp.

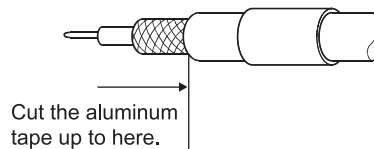

- 2) Insert a center contact pin into the internal conductor. Crimp the pin using a crimp tool to seal the gap between the center contact pin and the insulating material.

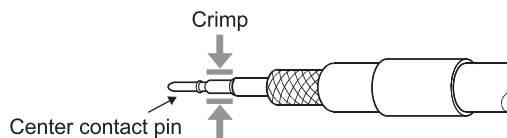

POINT	<ol style="list-style-type: none"> (1) Use a crimp tool specified for a BNC connector. (2) Do not crimp the junction of the insulating material and the center contact pin. (3) Horizontally insert the center contact pin into the insulating material and crimp the pin. If the pin is on the tilt, straight it.
--------------	---

- 3) After the crimp, check the crimp height of the crimp part. When the crimp height at the measurement position is between 1.4mm and 1.5mm, the pin is properly crimped.
If the crimp height is not between 1.4mm and 1.5mm, adjust the crimp tool and crimp the center contact pin again.

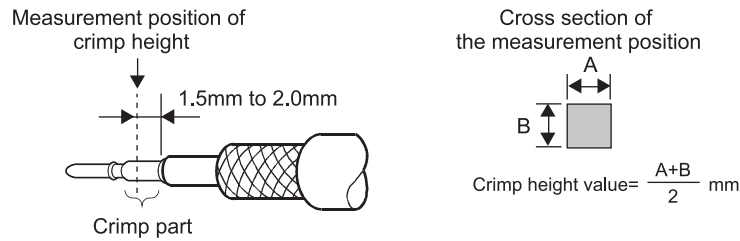

- 4) Hold the root of the coaxial cable and fully insert the cable into a plug. After inserting the cable, pull it lightly to check that the center contact pin is fixed. Move the crimp sleeve until it contacts with the plug.

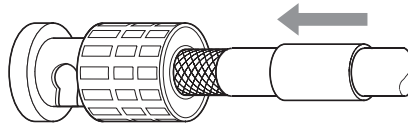

- 5) Crimp the crimp sleeve using the crimp tool with attention paid to the orientations of the crimp tool and connector. Do not pull the cable when crimping the sleeve.

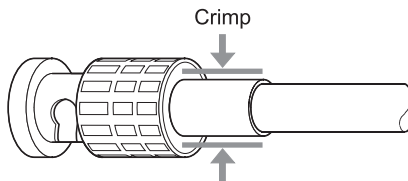

POINT
 Before connecting or disconnecting the coaxial connector, touch a grounded metal object to discharge the static electricity from the human body.
 Failure to do so may result in a module malfunction.

3.2 Function Specifications

The following introduces the MELSECNET/H remote I/O network functions.
The functions are listed below.

Basic functions	Cyclic transmission function (Periodic communication)	Communicating with input/output module	Section 3.2.1 (1)	
		Communicating with intelligent function module	Section 3.2.1 (2)	
	RAS functions	Output reset function for communication errors	Section 3.2.2 (1)	
		Hardware error time CPU operation mode setting	Section 3.2.2 (2)	
		Automatic return function	Section 3.2.2 (3)	
		Loopback function (Optical loop system)	Section 3.2.2 (4)	
		Station detach function (Coaxial bus systems)	Section 3.2.2 (5)	
		Transient transmission enabled even at CPU module error	Section 3.2.2 (6)	
		Checking the transient transmission abnormal direction time	Section 3.2.2 (7)	
		Dagnostic functions	Section 3.2.2 (8)	
Redundant power supply on a remote I/O station	Section 3.2.2 (9)			
Online module change in a remote I/O station	Section 3.2.2 (10)			
Application functions	Transient transmission function (Non-periodic communication)	Link dedicated instruction	Reading/writing remote I/O station intelligent function module buffer memory (REMFR/REMTO)	Section 7.1.1 (1)
			Remote I/O station system monitor	Section 7.2
	Device test for remote I/O station	Section 7.3		
	Multiplex transmission function (Optical loop system)	Section 7.4		
	Return sequence station number setting function	Section 7.5		
	Reserved station function	Section 7.6		
	Interrupt settings	Section 7.7		
	I/O assignment function	Section 7.8		
	Stopping/restarting the cyclic transmission and stopping link refreshing (Network test)	Section 7.9		
	Multiplex remote master function (Process CPU)	Section 7.10		
	Multiplexed remote master function for redundant system (Redundant CPU)	Section 7.11		
	Remote password	Section 7.12		
	Network diagnostics (Network monitor)	Section 8.1		

3.2.1 Cyclic transmission function (periodic communication)

The cyclic transmission function periodically exchanges data between the remote master station and remote I/O station using link device (LX/LY/LB/LW)

The following explains the differences between when the module connected to the remote I/O station is an I/O module and when it is an intelligent module connected to it.

(1) Communicating with I/O modules

The remote master station uses input/output X/Y(LX/LY) devices after the actual I/O for the host so that there can be communication with the I/O module on the remote I/O station.

To perform communications between the remote master station and the remote I/O station, write the network parameters to the remote master station.

The device range for communicating with each remote I/O station is set by the remote master station common parameters.

PLC parameters written to the remote I/O station will not cause problems with the I/O module communication, even with the default settings. Change the settings of the PLC parameters as needed.

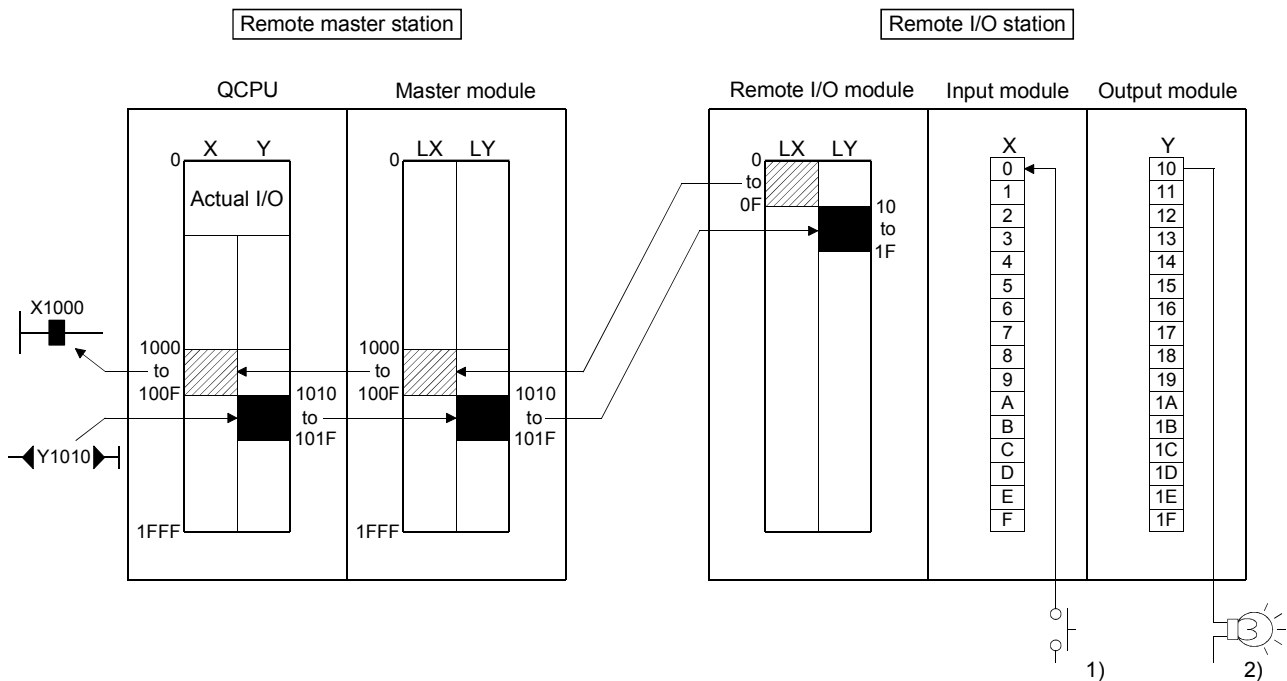

- 1) When X0 for the input module for the remote I/O station is set to on, the X1000 for the remote I/O station is set to on.
- 2) When Y1010 for the remote master station is set to on, the Y10 for the remote I/O station output module is set to on.

(2) Communicating with intelligent function modules

The remote master station can communicate with the intelligent function module mounted to the remote I/O station in the following four ways.

	Methods for communicating with the intelligent module	Features
(a)	By cyclic transmission (common parameters) + intelligent function module parameters (Automatic refresh target device W).	When the intelligent function module is mounted to a nearby slot of the CPU module, the same kind of sequence program can be created. Regular time data can be read without regard to timing
(b)	Dedicated instructions for the intelligent function module (REMFR,REMTO)	GX Configurator is not needed. Data can be communicated only when needed.
(c)	By cyclic transmission (common parameters) + intelligent function module parameters (Automatic refresh target device D). Remote I/O station parameters (parameters for transmitting between devices)	When the intelligent function module is mounted to a nearby slot of the CPU module, the same kind of sequence program can be created. In a way different from the method 1, it is also possible to set the intelligent function module parameters in the same way as the setting for the host.
(d)	Link dedicated instructions (READ,WRITE) Intelligent function module parameters (Automatic refresh target device D)	When the intelligent function module is mounted to a nearby slot of the CPU module, the same kind of sequence program can be created. Data can be communicated only when needed.

In communication methods (a), (c) and (d), when there is communicating between remote master station and remote I/O station, the network parameters are written to the remote master station and the PC parameters and intelligent function module parameters are written to the remote I/O station.

The device range for communicating with each remote I/O station is set by the remote master station common parameters.

PC parameters written to the remote I/O station will not cause problems with the intelligent function module communication, even with the default settings.

Change the settings of the PLC parameters as needed.

POINT							
(1)	Note that the number of intelligent function module parameters (initial setting, automatic refresh setting) that may be set is limited. If the number of parameters set exceeds the limited number, the remote I/O module detects the "SP. PARA ERROR (3301)" error. To auto refresh the excessive items, use the REMFR/REMTO instruction to read/write data from/to the intelligent function module.						
	<table border="1"> <thead> <tr> <th>Item</th> <th>No. of the parameters that can be set</th> </tr> </thead> <tbody> <tr> <td>Initial setting</td> <td>Up to 512</td> </tr> <tr> <td>Auto refresh setting</td> <td>Up to 256</td> </tr> </tbody> </table>	Item	No. of the parameters that can be set	Initial setting	Up to 512	Auto refresh setting	Up to 256
Item	No. of the parameters that can be set						
Initial setting	Up to 512						
Auto refresh setting	Up to 256						
	The number of parameters for initial setting is preset to each intelligent function module. To confirm the numbers of parameters for initial setting, refer to the user's manuals of the corresponding intelligent function modules. Refer to Section 5.2.1(4) for the way to count the number of parameters for automatic refresh setting.						
(2)	A remote master station cannot execute the dedicated instructions for intelligent function module to the intelligent function modules mounted in a remote I/O station.						

- (a) The CPU module reads and writes intelligent function module data at fixed intervals, using the following devices and setting.
 - X/Y (LX/LY) and B/W (LB/LW) devices that are set with common parameters
 - Intelligent function module parameters (auto refresh setting) written to the remote I/O module

The intelligent function module parameters are created by GX Configurator. (For more detailed information, refer to the manual for the intelligent function module you are using.)

... With this method, a sequence program can be created to allow communication in the same way as with an intelligent function module mounted to the same base units as the CPU module.

The analog input values for the analog-digital converter module, the current values of the high speed counter module and others are periodically read and suited for periodic writing of the analog output value for the digital-analog converter module.

POINT

With this method, since data is read and written periodically, there is no interlock with the intelligent function module.

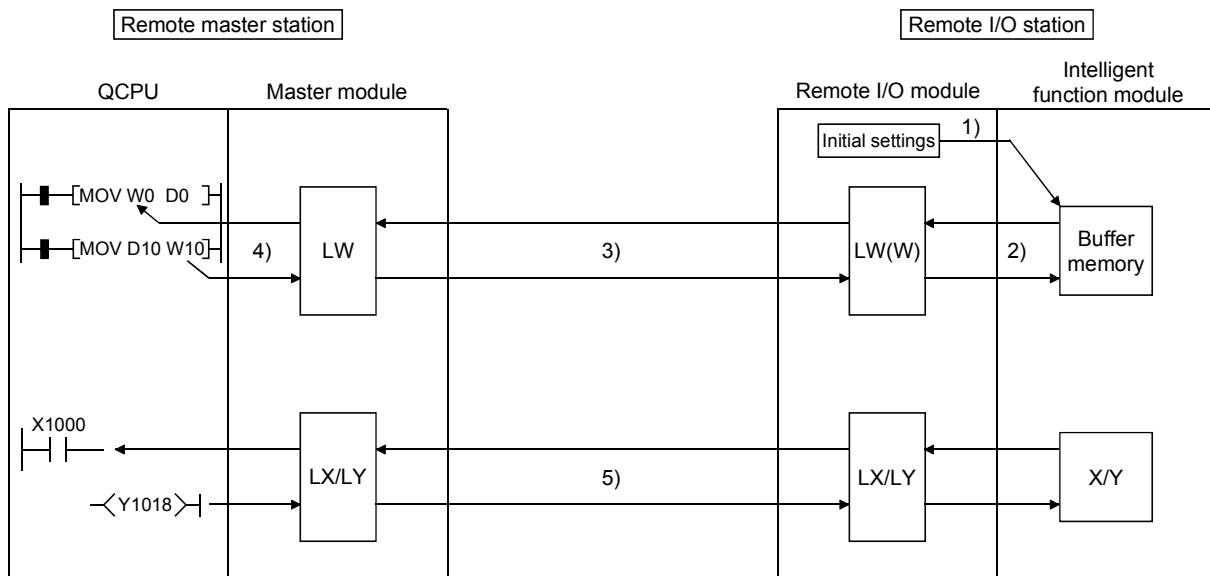

[Buffer memory]

- 1) GX Configurator is used to write the initial settings for the intelligent function module and the automatic refresh settings to the remote I/O station remote I/O module.
- 2) The remote I/O module follows the automatic refresh settings and refreshes the data in the buffer memory of the intelligent function module to link register W of the remote I/O module.
- 3) Link register W, follows the common parameters set in the remote master station for communication between the remote master station and the remote I/O station.

- 4) QCPU follows the refresh parameters and refreshes link register W between QCPU and the master module.

[Input/output]

- 5) X/Y(LX/LY) is the same as communication with I/O module.

- (b) The CPU module reads or writes data using a link dedicated instruction (REMFR/REMTO).

With a link dedicated instruction (REMFR/REMTO), data are directly read from or written to the buffer memory of the intelligent function module on the remote I/O station.

... This method can be used for the following applications.

- During intelligent function module control, when reading and writing data with the sequence program only when data is needed.
- When an interlock with the intelligent function module is desired.
- When link register W to remote I/O station is insufficient.

Moreover, this method can be used for reading and writing data when there is no GX Configurator available.

Refer to Section 7.1.1 for details on the REMFR/REMTO instructions.

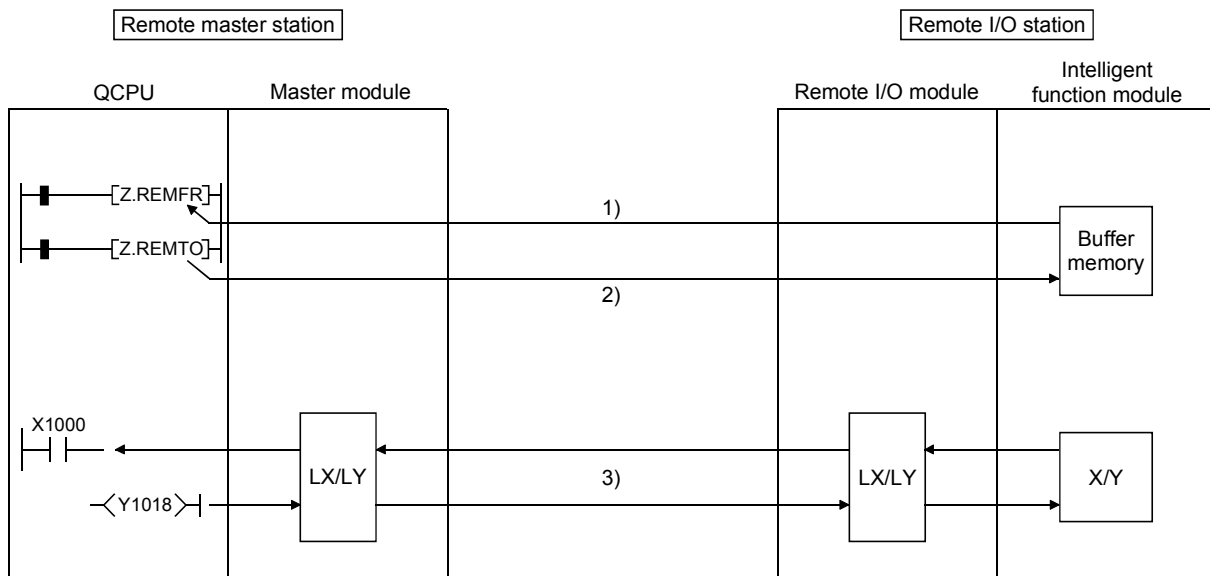

[Buffer memory]

- 1) QCPU uses the REMFR instruction to read the contents of the intelligent function module buffer memory.
- 2) QCPU uses the REMTO instruction to write the contents in the intelligent function module buffer memory to the intelligent function module.

[Input/output]

- 3) X/Y(LX/LY) is the same as communication with I/O module.

- (c) The CPU module reads and writes intelligent function module data at fixed intervals, using the following devices and setting.
 - X/Y (LX/LY) and B/W (LB/LW) devices that are set with common parameters
 - Intelligent function module parameters (auto refresh setting) written to the remote I/O module

The difference between this and (a) is that with the automatic refresh settings for the intelligent function module parameters, the automatic refresh destination of the intelligent function module is remote I/O module data register D. Data register D, uses the PLC parameters for the remote I/O module to transmit to link register W among devices.

· · · With this method, a sequence program can be created to allow communication in the same way as with an intelligent function module mounted to the same base units as the CPU module. The analog input value for the analog-digital converter module, current value for the high-speed count module and others are periodically read to suit the digital-analog converter module analog output value being periodically written. In addition, there is no need to revise the intelligent function module parameters even if the network parameters for the remote master station are changed.

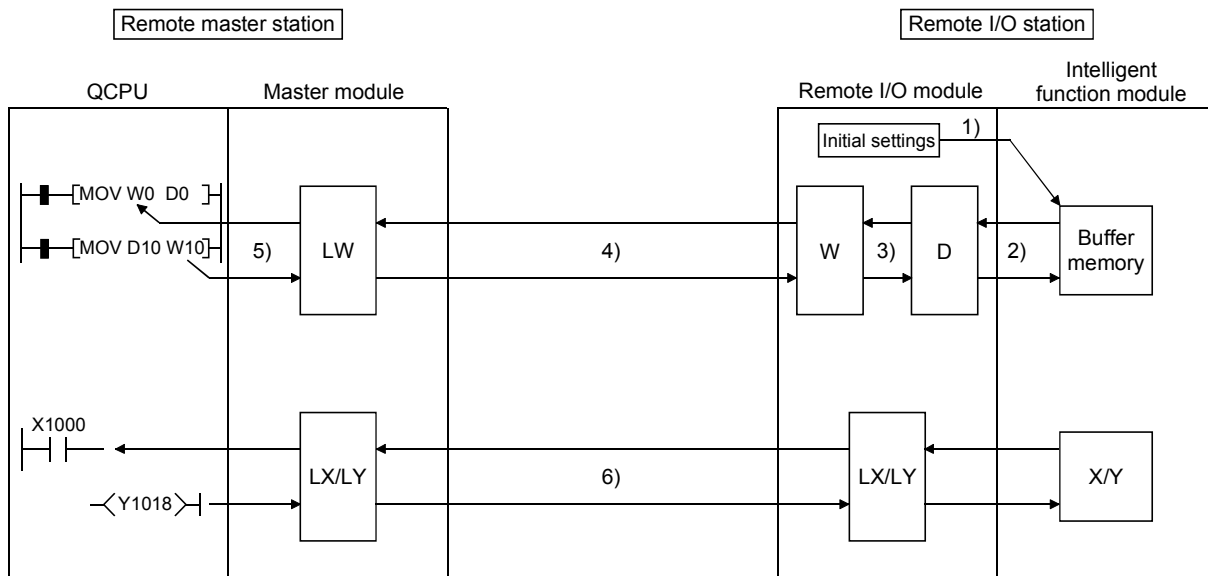

[Buffer memory]

- 1) GX Configurator is used to write the initial settings for the intelligent function module and the automatic refresh settings to the remote I/O station remote I/O module.
- 2) The remote I/O module follows the automatic refresh settings and refreshes the data in the buffer memory of the intelligent function module to the data register D of the remote I/O module.
- 3) The remote I/O module uses transfer among devices for the PLC parameters written to the host to send data register D to link register W.

- 4) Link register W, follows the common parameters set in the remote master station for communication between the remote master station and the remote I/O station.
- 5) Link register W between the master module and QCPU are refreshed.

[Input/output]

- 6) X/Y(LX/LY) is the same as communication with I/O module.

(d) The CPU module reads or writes data register D of the remote I/O module with a link dedicated instruction (READ/WRITE).

To data register D, intelligent function module data are refreshed, using intelligent function parameters (auto refresh setting).

... This method can be used for the following applications.

- During intelligent function module control, when reading and writing data with the sequence program only when data is needed.
- When link register W to remote I/O station is insufficient.

For details on the read/write instructions, refer to the Q corresponding MELSECNET/H network system reference manual (PLC to PLC network).

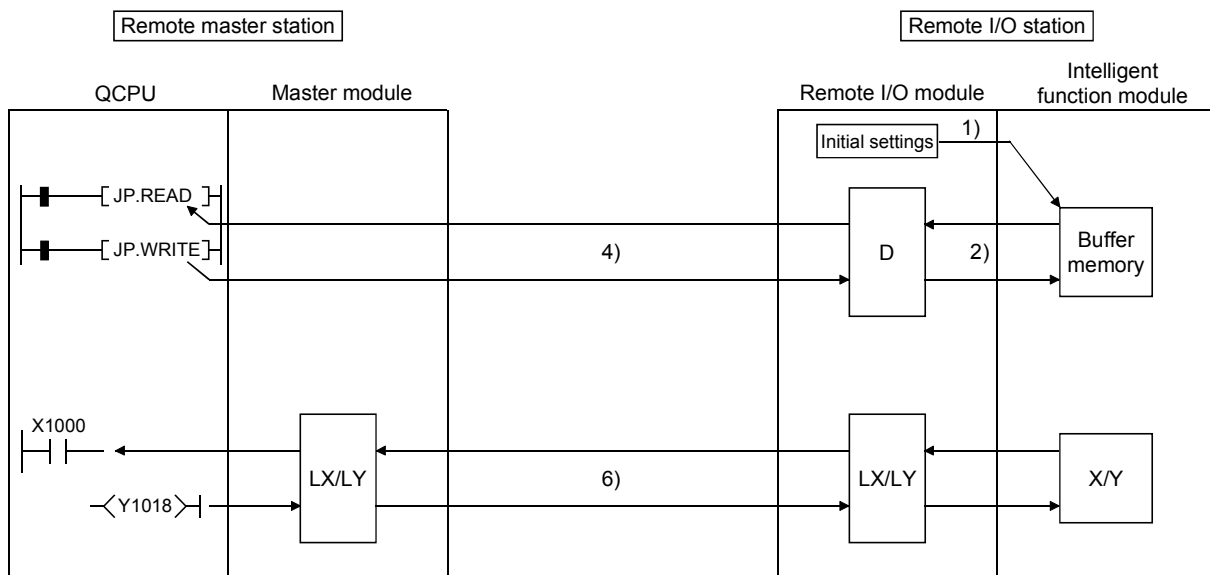

[Buffer memory]

- 1) GX Configurator is used to write the initial settings for the intelligent function module and the automatic refresh settings to the remote I/O station remote I/O module.
- 2) The remote I/O module follows the automatic refresh settings and refreshes the data in the buffer memory of the intelligent function module to the data register D of the remote I/O module.
- 3) QCPU uses the read/write instructions to read and write to remote I/O module data register D.

[Input/Output]

- 4) X/Y(LX/LY) is the same as communication with I/O module.

3.2.2 RAS functions

RAS stands for "Reliability", "Availability" and "Serviceability" and is an automated facility for overall ease of use.

(1) Output reset function for communication errors

Remote I/O net will set all output of remote I/O stations to off when there is a data link error.

It will also set all output of remote I/O stations to off when the data links are operating properly but the remote master station CPU module is down.

To hold the output of a remote I/O station even in the case of an error, set "Error time output mode" to "Hold" in the detailed I/O assignment setting in "PLC Parameter" for the remote I/O station.

Refer to the GX Developer Operating Manual for more information about setting the PLC parameters.

If a data link communication error or communication stop occurs on a remote I/O station, the master station holds the data (X, B, W) received from the remote I/O station immediately before the error.

POINT

To hold output analog values of a digital-analog converter module, set "Error time output mode" to "Hold" and retain the CH Output enable/disable flag status.

(2) Hardware error time CPU operation mode setting*1

This setting specifies whether to stop or continue the operation of a remote I/O station when a hardware error occurs in an intelligent function module on the remote I/O station.

The hardware error time CPU operation mode is set in I/O assignment in PLC parameter.

For the PLC parameter setting method, refer to GX Developer Operating Manual.

(a) When set to "Stop" (default)

Automatic refresh of all intelligent function modules on the remote I/O station is stopped.

(b) When set to "Continue"

Automatic refresh is continued for modules other than the intelligent function module in which a hardware error has occurred.

*1: The hardware error time CPU operation mode setting is available for the following remote I/O module and GX Developer:

- Remote I/O module: First five digits of serial No. is "10012" or later.
- GX Developer: GX Developer: Version 8.62Q or later

(3) Automatic return function

When a station disconnected from a network due to a data link error recovers from the error, the station is automatically reconnected to the network and restarts data link.

(a) When a remote I/O station restarts data link (the "D.LINK" LED is lit.)

The remote I/O station resets all of the modules mounted on the station. If data link is resumed by connecting/disconnecting the link cable, the modules are not reset.

(b) When parameter change or reset of a remote I/O station (including power cycle) was performed

After parameters of a remote I/O station are changed, if parameter change or reset is performed at the remote master station, or if the remote I/O station is reset (power off and then on, or the reset switch turned on), the modules will be reset when the remote I/O station returns to the system to resume the data link. Consequently, even if the output setting under a CPU error is set to HOLD (retention) in an output module, digital-analog converter module, or temperature control module, output cannot be retained when data link is resumed.

1) The remote I/O station No. 2 is disconnected due to a data link error.

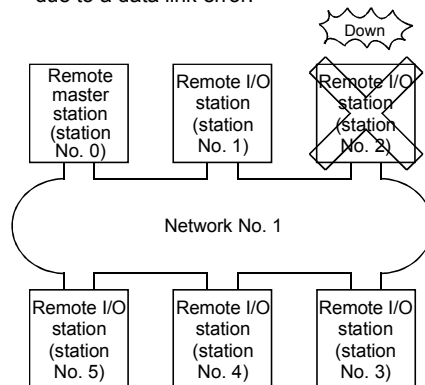

2) The station No. 2 recovers to the normal status and returns to the system.

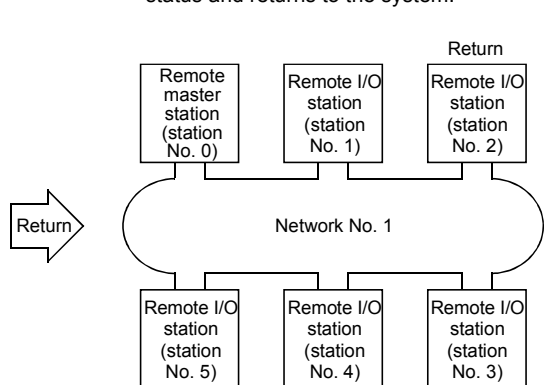
**POINT**

There is a limit to the number of faulty stations that can return to the system within one link scan. For details, refer to Section 5.1.4, "Supplementary Settings."

(4) Loopback function (optical loop system)

In the optical loop system, the transmission path is dual-structured. When an error occurs in a transmission path, the faulty area is disconnected by switching the transmission path from the forward loop to the reverse loop or from the reverse loop to the forward loop, or performing a loopback. The transmission is continued normally between the stations that are still able to perform data communication.

(a) When normal

The data link is performed using the forward loop (or the reverse loop).

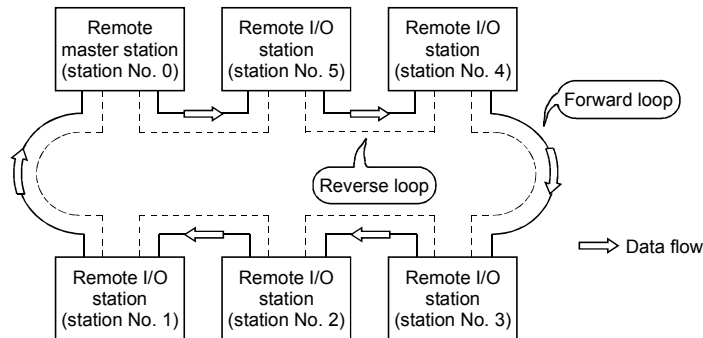

(b) When abnormal

1) Disconnection in the forward loop (reverse loop)

The data link continues using the reverse loop (forward loop).

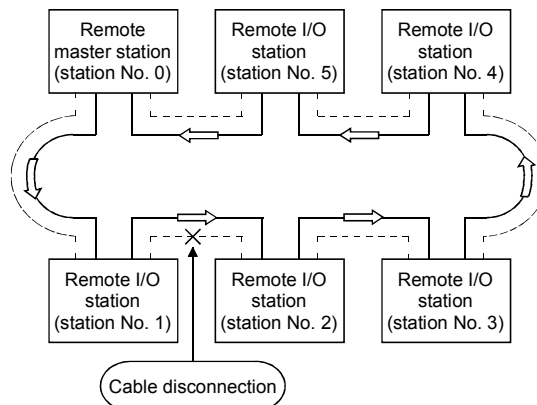

2) When some of the stations are down

The data link continues excluding the stations that are down.

When two or more stations are down, the data link cannot be performed with the station located between the stations that are down.

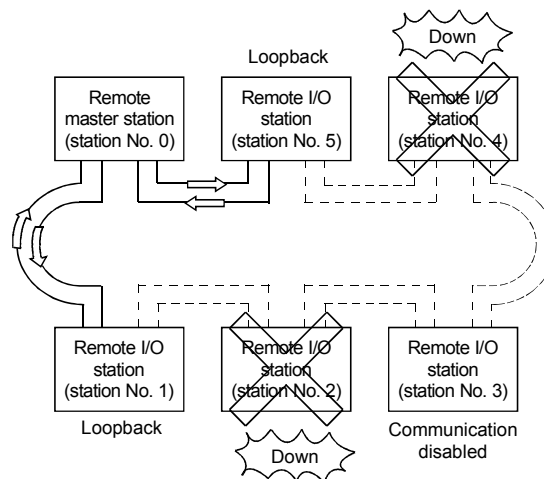

(c) Precautions in using the optical loop system

- 1) When the cable is inserted or removed, the line (forward loop/reverse loop) may be switched, but the data link will be performed normally.
- 2) When the loopback is being executed due to a cable disconnection, both the forward and reverse loops may be recognized as normal depending on the condition of the cable disconnection.
Whether the forward/reverse loop is normal/abnormal is determined by the status of "RD" (receive) of the loopback station.

(Example)

In the cases described below, the data link continue by dividing the network into two loops: "1M_R-1R5-1R6"

<Loop containing 1M _R 1-1R4-1R5>		} Forward loop normal Reverse loop normal
1M _R 1:	Forward loop normal/reverse loop normal	
1R4 :	Forward loop normal/reverse loop normal	
1R5 :	Forward loop normal/reverse loop normal	
<Loop containing 1R1-1R2-1R3>		} Forward loop abnormal Reverse loop abnormal
1R1 :	Forward loop " <u>RD</u> " abnormal/reverse loop normal	
1R2 :	Forward loop normal/reverse loop normal	
1R3 :	Forward loop normal/reverse loop " <u>RD</u> " abnormal	



Communication disabled

An RD abnormal detection in the forward loop → Loopback with the reverse loop

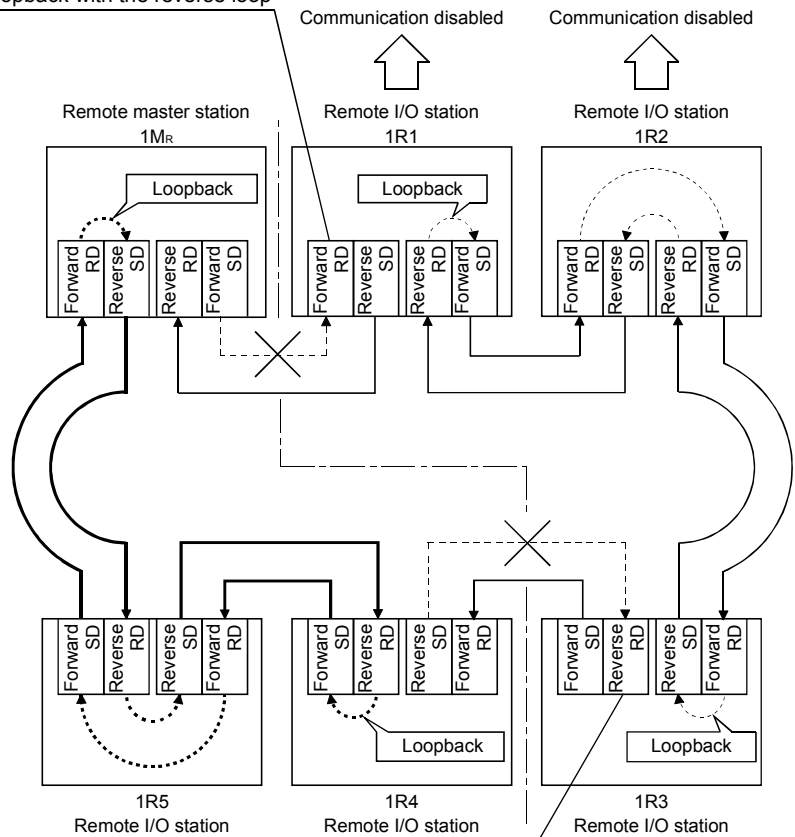

An RD abnormal detection in the reverse loop → Loopback with the forward loop

Communication disabled

REMARKS

If the network module has become faulty, a loopback may not be made depending on the fault.

In that case, the network may stop. Identify the faulty network module in the following method.

- (1) Check the indicator LEDs (RUN LED off, ERR. LED on) of all network modules for a faulty station.
- (2) Power off all stations and power them on in order, starting from the remote master station. At that time, check up to which station the network operates properly.

Change the network module where the fault has been detected, and confirm that the network is restored to normal.

(5) Station detach function (coaxial bus system)

In the coaxial bus system, even if the power to a connected station is turned off, the data link continues between other stations which are still able to perform data communication.

(a) When normal

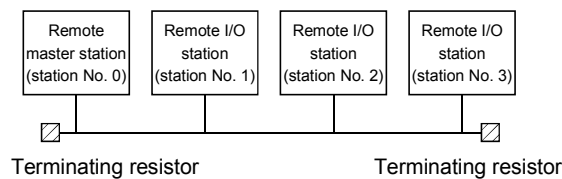

(b) When abnormal

The data link continues excluding the station that is down.

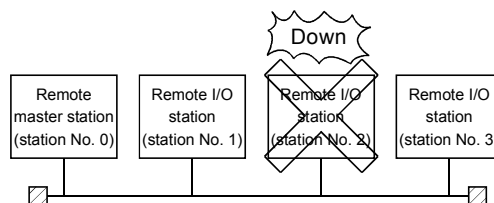

POINT

When a cable disconnection occurs, the data link cannot be performed because there will be no terminating resistors.

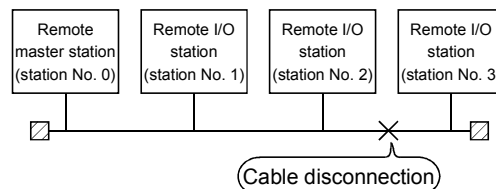

In addition, even if the cable is normal, the data link cannot be performed if a terminating resistor is detached from an F-type connector.

- (6) Transient transmission enabled even at CPU module error
 By using this function, the network module can continue the transient transmission even if an error that stops the CPU module occurs while the system is operating.
 The description of the error of the corresponding station can be checked from other stations using GX Developer.

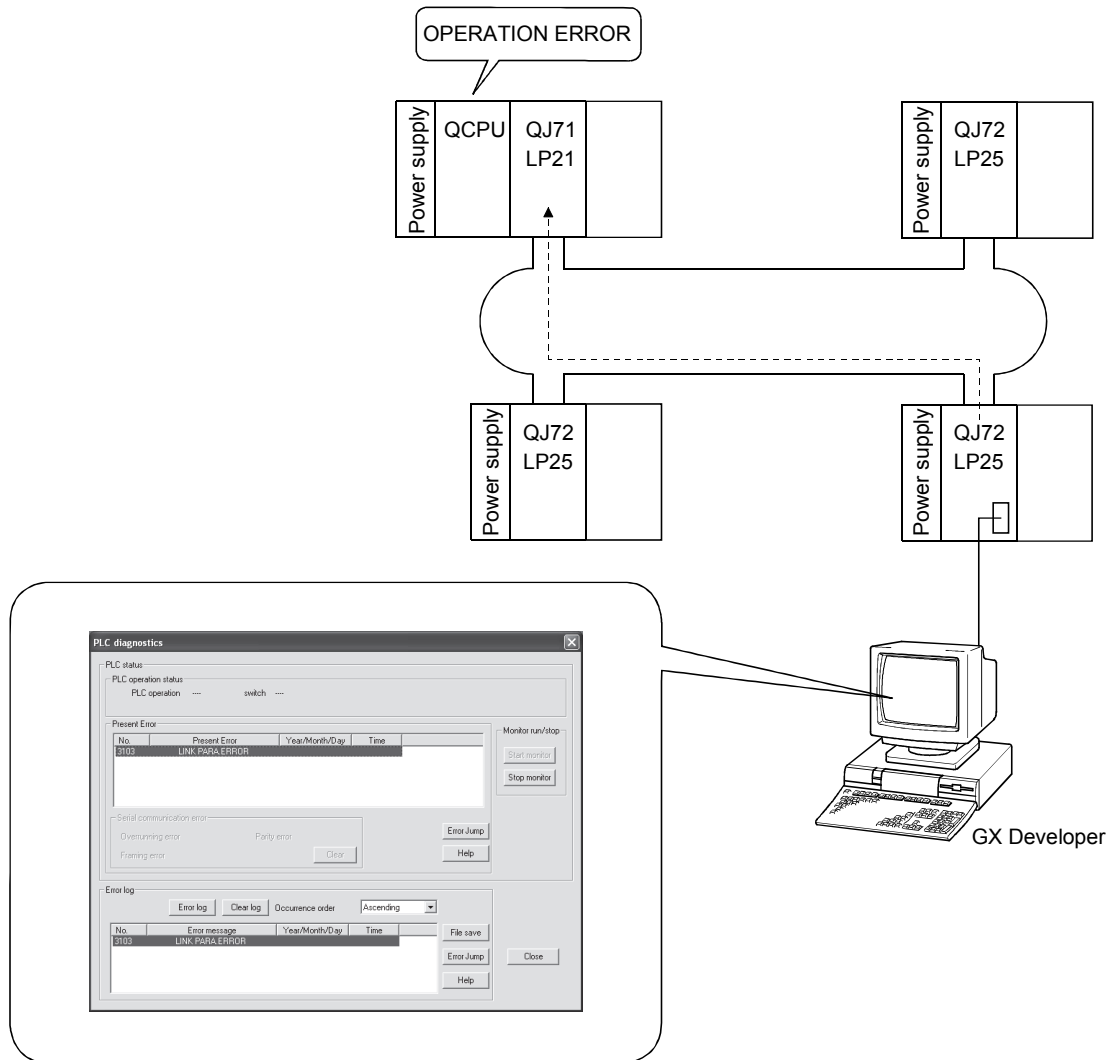

The following table lists the operations of the cyclic and transient transmissions for each CPU module status.

CPU module status	Rank	Cyclic transmission	Transient transmission
	Battery error Annunciator error ON, etc. (Continue error)		
Parameter error Instruction code error, etc. (Stop error)	Medium error	Stopped	Enabled
CPU reset, etc. (MAIN CPU down)	Major error	Stopped	Disabled*

*: Accessing the remote master station from GX Developer or like using the transient function will result in a communication error.

(7) Abnormal detection time

By using this function, the "Time," "Abnormal detection network number," and "Abnormal detection station number" can be checked when a transient transmission (READ, WRITE and other instructions) ends abnormally.

The time log can be used to identify the network problems and to determine how the network can be improved.

For details on the instructions, refer to the Q corresponding MELSECNET/H Network System Reference Manual (PLC to PLC network).

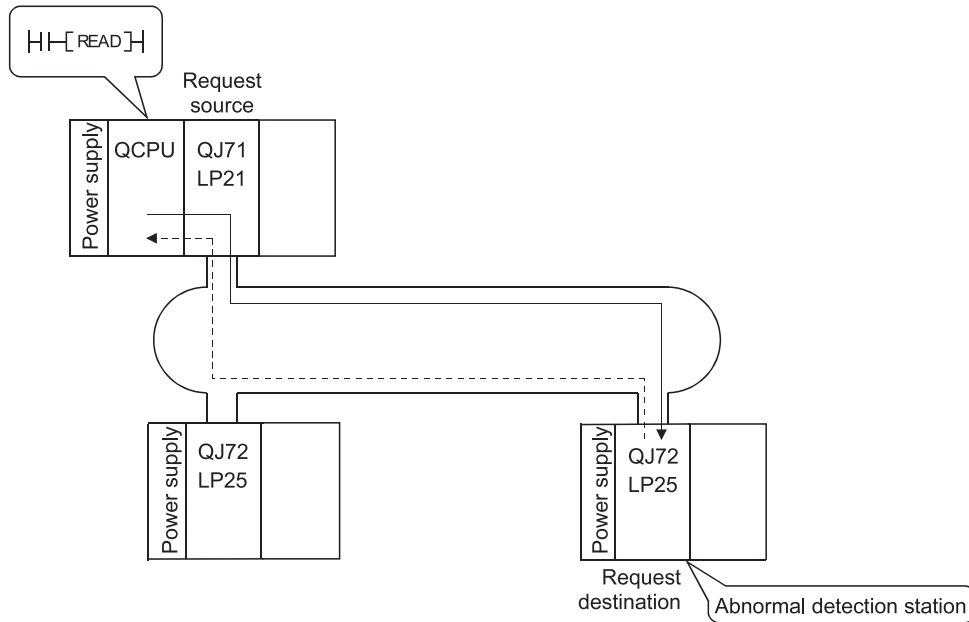

(8) Diagnostic function

The diagnostic function is used to check the network's line status and the module setting status.

The diagnostic function consists mainly of following two types of tests:

- Offline tests
- Online tests

POINT
Execute the online tests when the network module is communicating (T.PASS LED is on). An error occurs if any of the online tests is executed from a station that has been disconnected from the data link.

1) Offline tests

The network module's hardware and the data link cable wiring can be checked at the system startup by setting the network module or GX Developer to the test mode.

Item	Description	Optical loop system	Coaxial bus system	Reference section
Self-loopback test	Checks hardware including the send/receive circuits and the cables of the transmission system of an individual network module.	○	○	Section 4.7.1
Internal self-loopback test	Checks hardware including the send/receive circuits of the transmission system of an individual network module.	○	○	Section 4.7.2
Hardware test	Checks hardware inside the network module.	○	○	Section 4.7.3
Forward loop/reverse loop test	Checks the wiring status of the forward and reverse loops in the status in which all the stations are connected. (Remote master station only)	○	×	Section 4.9.2

2) Online tests

The status of a line and other items can be easily checked with GX Developer.

If an error occurs while the system is in operation, the diagnostics listed below can be executed while remaining in the online status.

Item	Description	Optical loop system	Coaxial bus system	Data link status (cyclic transmission or transient transmission)	Reference section
Loop test	Checks the line status.	○	×	Pause	Section 4.10.1
Setup confirmation test	Checks for duplicate control stations and station numbers.	○	○	Pause	Section 4.10.2
Station order check test	Checks the order of stations connected in the directions of the forward and reverse loop.	○	×	Pause	Section 4.10.3
Communication test	Checks whether or not the transient transmission can be performed normally. It also checks the routing parameter settings.	○	○	Continue	Section 4.10.4

(9) Redundant power supply on a remote I/O station

A redundant power supply can be configured on a remote I/O station by mounting a pair of power supply modules onto the dedicated base unit.

A redundant power supply offers the following advantages.

- 1) The remote I/O station can continue the operation after either power supply module stops power supply
 The remote I/O station with a redundant power supply can continue the operation even if either of the power supply modules stops power supply, as the remaining power supply module supplies power instead.
- 2) A faulty power supply module can be replaced online (hot-swapping)
 A faulty power supply module can be replaced online (hot-swapping), as the remote I/O station operates using the remaining power supply module.

To take advantages of the redundant power supply, connect separate power supplies to the power supply modules.

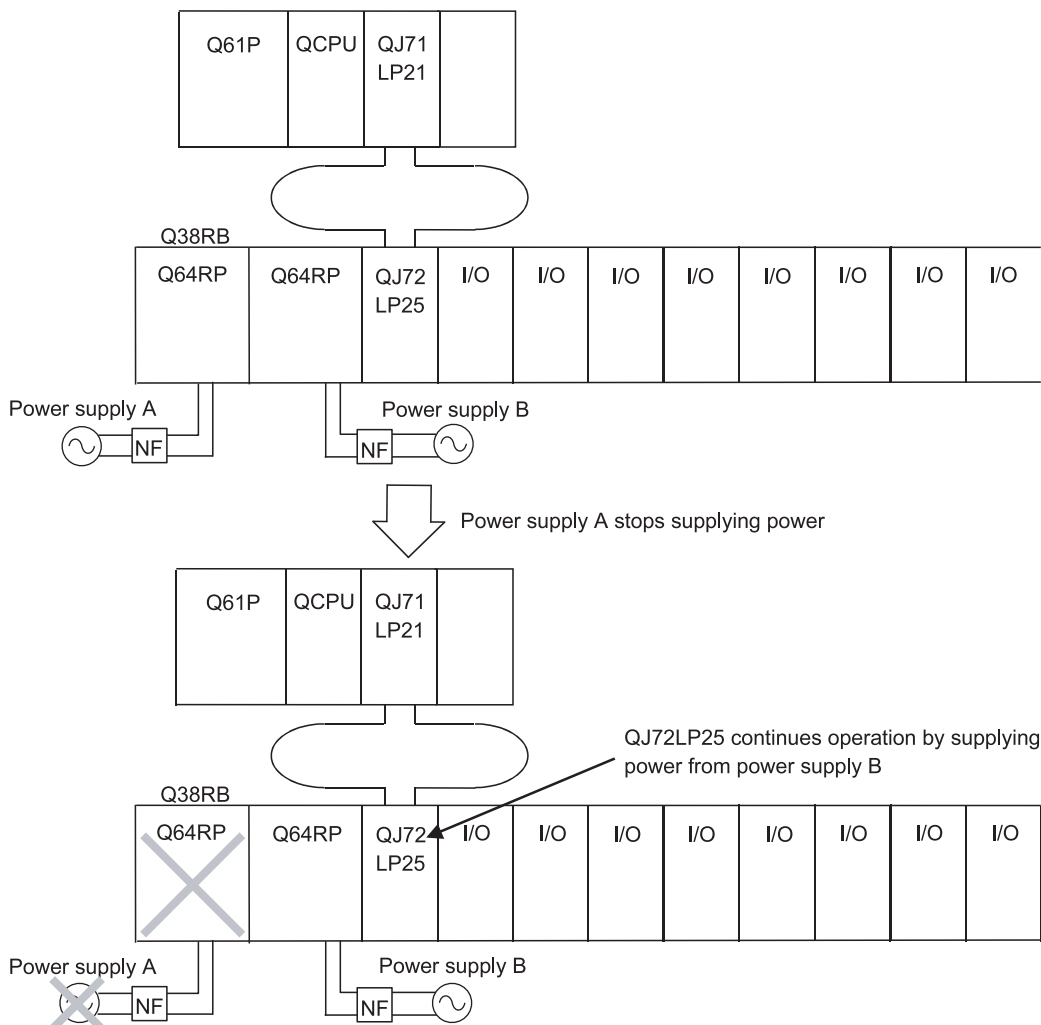

If either of the power supply modules stops supplying power, the remote I/O station detects error code 1510 "SINGLE PS DOWN" or 1520 "SINGLE PS ERROR" (moderate error). Errors in the remote I/O station can be confirmed through the PLC diagnostics/system monitor of GX Developer (version 8.17T or later), the ERR. LED of the remote I/O module, and the ERR contact of the power supply module.

POINT

For the specifications of Q3□RB/Q6□RB Redundant power supply base unit and Q6□RP redundant power supply module, refer to QCPU User's Manual (Hardware Design, Maintenance and Inspection).

- (a) Modules needed to configure a redundant power supply in a remote I/O station

To configure a redundant power supply in a remote I/O station, use the modules shown below.

- 1) Main base unit: Q3□RB
- 2) Extension base unit: Q6□RB
- 3) Power supply module: Q6□RP
- 4) Remote I/O module: QJ72LP25-25, QJ72LP25G, QJ72LP25GE, and QJ72BR15 (function version D)

- (b) Link special register used for configuring a redundant power supply

The remote master station can confirm the status of the power supplies of remote I/O stations using the link special registers listed below.

If either of the power supplies stops supplying power, the remote I/O station detects error code 1510 "SINGLE PS DOWN" or 1520 "SINGLE PS ERROR" (moderate error).

No.	Name	Description	Availability																																																														
			Control station		Normal station		Remote master station		Remote I/O station																																																								
			Optical	Coaxial	Optical	Coaxial	Optical	Coaxial	Optical	Coaxial																																																							
* 1 SW0088 • SW0089 • SW008A • SW008B	Operation status of each station CPU (2)	The CPU status of each station is stored (including the host). Only normal stations out of SW0070 to 0073 are effective. 0: normal (including the maximum station No. or later and reserved stations) 1: minor error <table border="1" style="margin-left: auto; margin-right: auto;"> <thead> <tr> <th></th> <th>b15</th> <th>b14</th> <th>b13</th> <th>b12</th> <th>to</th> <th>b4</th> <th>b3</th> <th>b2</th> <th>b1</th> <th>b0</th> </tr> </thead> <tbody> <tr> <td>SW0088</td> <td>16</td> <td>15</td> <td>14</td> <td>13</td> <td>to</td> <td>5</td> <td>4</td> <td>3</td> <td>2</td> <td>1</td> </tr> <tr> <td>SW0089</td> <td>32</td> <td>31</td> <td>30</td> <td>29</td> <td>to</td> <td>21</td> <td>20</td> <td>19</td> <td>18</td> <td>17</td> </tr> <tr> <td>SW008A</td> <td>48</td> <td>47</td> <td>46</td> <td>45</td> <td>to</td> <td>37</td> <td>36</td> <td>35</td> <td>34</td> <td>33</td> </tr> <tr> <td>SW008B</td> <td>64</td> <td>63</td> <td>62</td> <td>61</td> <td>to</td> <td>53</td> <td>52</td> <td>51</td> <td>50</td> <td>49</td> </tr> </tbody> </table> In the table, 1 to 64 indicate station No.		b15	b14	b13	b12	to	b4	b3	b2	b1	b0	SW0088	16	15	14	13	to	5	4	3	2	1	SW0089	32	31	30	29	to	21	20	19	18	17	SW008A	48	47	46	45	to	37	36	35	34	33	SW008B	64	63	62	61	to	53	52	51	50	49	○	○	○	○	○	○	○	○
	b15	b14	b13	b12	to	b4	b3	b2	b1	b0																																																							
SW0088	16	15	14	13	to	5	4	3	2	1																																																							
SW0089	32	31	30	29	to	21	20	19	18	17																																																							
SW008A	48	47	46	45	to	37	36	35	34	33																																																							
SW008B	64	63	62	61	to	53	52	51	50	49																																																							

* 1: Effective only when SB0047 is OFF. When this signal is turned ON (error), the data just before ON are held.

The link special register stores minor errors caused by the factors below in addition to power supply disconnection.

- When an error specified as "Continue" in the "operation mode under error condition" in the PC RAS settings of parameters (fuse blown or module verification error) occurs

- (c) Precautions on configuring a redundant power supply
- 1) If either of the power supply modules fails and it needs to be replaced in a remote I/O station including redundant power supply, replace the other power supply module as well, in order to prevent the potential accidents
Also, it is recommended to replace power supply modules five years after the remote I/O station starts to run.
For procedures for replacing a redundant power supply module in a normal operating state, refer to Section 8.5.
 - 2) For the Q64RP power supply modules for the redundant power supply system, it is recommended to supply AC power from one of them and to supply power from the other via UPS (Uninterruptible Power Supply).
Use the on-line UPS or line interactive UPS, of which voltage distortion is less than 5%. Or use the off-line UPS, Mitsubishi FREQUPS-F Series with serial No. P or later. (Example: FW-F10-0.3K/0.5K).
Do not use the off-line UPS other than above.
 - 3) When mounting modules onto the Q38RB or Q68RB redundant power supply base unit, make sure that the sum of 5VDC current consumption of them is within 8.5 A, the rated current value of a power supply module.
 - 4) Connect a NF (non-fuse breaker) to each power supply module so that power supply modules can be shut down separately when either of power supply modules has failed.
 - 5) The output of the ERR contact of the power supply module mounted on a main or extension base unit is turned off when AC/DC power supply is not input or a power supply module error is detected.
 - 6) The output of the ERR contact of the power supply module mounted on a main base unit is turned off when an error that stops the remote I/O module has occurred.

REMARKS

For a remote I/O station including redundant power supply configuration, remote I/O modules of function version C or later can also be used.

However, follow the precautions below.

- (1) Precautions on redundant power supply
 - When power supply fails, the remote I/O module does not detect an error code. In addition, errors (minor errors) are not noticed to the remote master station.
 - When power supply fails, the remote I/O module does not store the error in link special registers SW0088 to 8B.
- (2) Precautions on the ERR contact of power supply module
 - When an error that stops a remote I/O module operation occurs, the output of the ERR contact is not turned off.
 - When the remote I/O module is mounted on the main base unit, the output of the ERR contact is always OFF.

When it is mounted on the extension base unit, the output is turned off in the case where AC/DC power supply is not input or the ERR contact is turned off due to detection of a power supply module error.

(10) Online module change on a remote I/O station

Online module change is the function for replacing a Q series module mounted on the main base unit or extension base unit of a remote I/O station while the station is operating.

Using this function, a faulty module can be replaced with a module of the same model while the station is operating.

POINT	
(1)	A new module cannot be added and a module cannot be replaced with different model by using the online module change.
(2)	Perform online module change after confirming that the system outside the programmable controller system will not malfunction.
(3)	In order to prevent electric shocks or malfunction, provide a switch or other method to turn off the external power supply of the module to be replaced online.
(4)	In order to confirm the content shown below, it is recommended to perform online module change on an actual system in advance to verify that no error is found in the operations of the modules out of the scope of change. <ul style="list-style-type: none"> • There is no error in the method and configuration for disconnecting external devices. • There is no impact on the module by turning on/off the switches.
(5)	Do not install/remove the module to/from the base unit more than 50 times after the first use of the product. (IEC 61131-2 compliant) Failure to do so may cause malfunction.

(a) Conditions for online module change on a remote I/O station

Online module change can be performed in the following cases:

- 1) Modules that can be replaced online (hot-swappable) on remote I/O stations

Hot-swappable modules are listed in the following table.

Module type		Restriction
Input module		No restriction
Output module		
I/O combined module		
Intelligent function module	Analog-digital conversion module	Function version "C"
	Channel isolated high resolution analog-digital converter module	
	Channel isolated high resolution analog-digital converter module (With signal conditioning function)	
	Digital-analog converter module	
	Channel isolated digital-analog module	
	Temperature control module	
	Thermocouple input module	
	Channel isolated thermocouple/micro voltage input module	
	Channel isolated thermocouple input module	
	RTD Input Module	
	Channel isolated temperature input module	
Channel isolated pulse input module		

Modules other than above cannot be replaced online.

For whether the intelligent function module can be replaced online and replacement procedure, refer to the manual of the intelligent function module used.

- 2) GX Developer versions required for online module change on a remote I/O station
To perform online module change, GX Developer Version 8.18U or later is required.
In addition, online module change can also be performed from GX Developer via a network.
- 3) Remote I/O station configuration for online module change
Online module change can be performed for Q3□B or Q3□RB main base unit and the modules mounted on the Q6□B or Q6□RB extension base unit.
Online module change cannot be performed for the modules mounted on the following base units:
 - Q32SB, Q33SB, or Q35SB slim type main base unit
 - Q5□B extension base unit (the modules mounted on a main base unit cannot be replaced online. However, the modules mounted on a Q6□B extension base unit can be replaced.)
- 4) Control status of the remote I/O module
Online module change can be performed when a stop error has not occurred on the remote I/O module. In addition, online module change can be performed when an error that allows the system to continue operation occurs.
However, if either of the following occurs while online module change is being performed, the online module change is suspended.
 - The remote I/O module has been reset.
 - A stop error has occurred.
- 5) Number of modules that can be replaced online
Only one module can be replaced on a remote I/O station while online module change is performed once.
More than one module cannot be replaced simultaneously.

(b) Restrictions online module change operation

The following operations cannot be performed while online module change is performed.

- 1) Issue an online module change request from more than one GX Developer to a remote I/O module.
- 2) Write parameters in the remote I/O module being replaced online.

POINT

If an online module change request is issued from other GX Developer to a remote I/O module being replaced online, the message below is displayed. Confirm the message, and select "Yes" or "No."

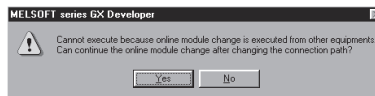

• When "Yes" is selected

The operation of online module change is switched to GX Developer (2), which issued the request latter. (Operation is continued from the status before switching.)

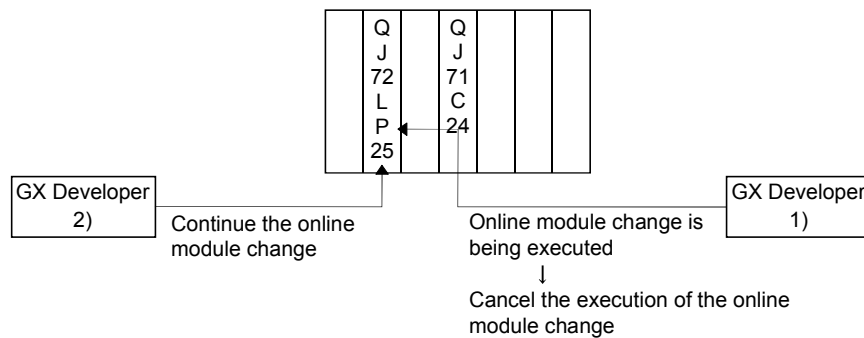

• When "No" is selected

The operation of online module change (GX Developer (2)), which was the latter request, is canceled. (The online module change being executed first (GX Developer (1)) is continued.)

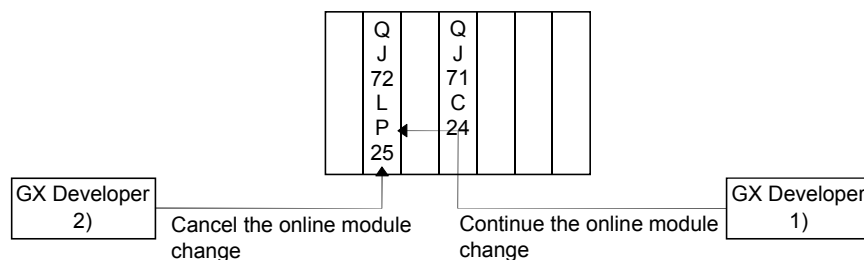

- 3) If an error has occurred on the target remote I/O module, the module holds the error even after online module change is completed. Therefore, it is necessary to clear the error by clearing the error using SM50 and SD50 on the programmable controller CPUs of the remote I/O station and master station.
Reset the error in the order below:
 - a) Remote I/O station
 - b) Programmable controller CPU of the master station
- 4) When the REMTO/REMFR instruction is executed for an intelligent function module under online module change, the system turns to the waiting for execution status without detecting an error. The instruction is resumed after the online module change has finished.
The completion flag of the instruction is not turned on in the waiting for execution status.

(c) Procedure of online module change

This section describes the procedure of the online module change of the I/O module.

For the procedure of the online module change of the intelligent function module, refer to the manual of the intelligent function module used.

POINT	It is recommended to turn off the output (Y) from the output module or I/O combined module in advance.
--------------	--

- 1) Select "Diagnostics" → "Online Module Change" on GX Developer to enter the "Online module change" mode.

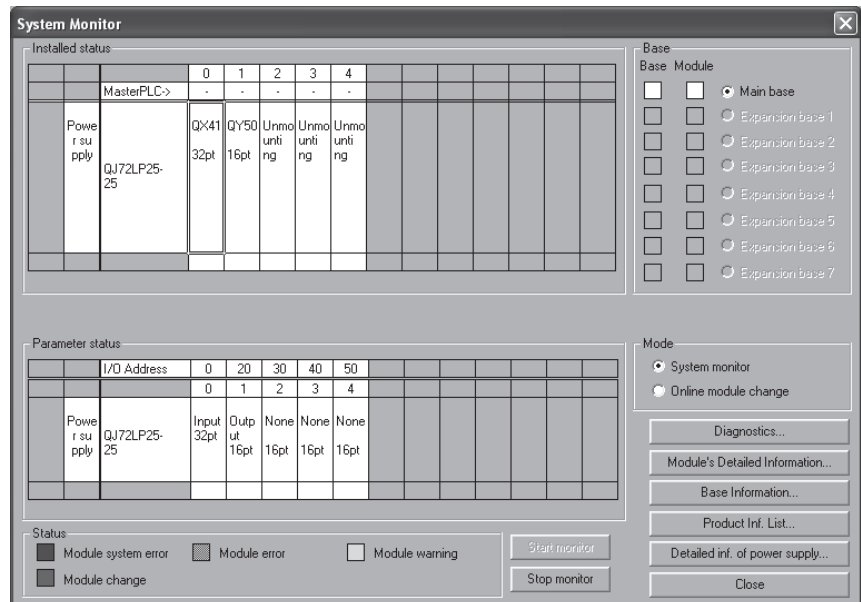

- 2) Double-click the module to be replaced online to display the Online module change screen.
(The table below indicates the communication status of the module to be replaced online when the screen below is displayed.)

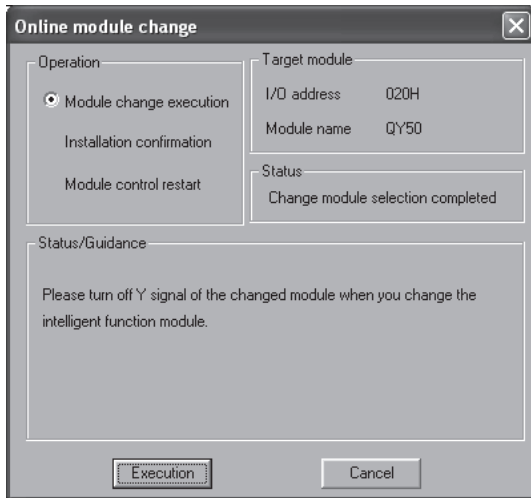

Target modules and items	Execute/not execute
Input module refreshing	Execute
Output module refreshing	Execute
I/O combined module	
Input refreshing	Execute
Output refreshing	Execute
Intelligent function module	
Input refreshing	Execute
Output refreshing	Execute
Intelligent module automatic refreshing	Execute
Buffer memory batch monitoring	Execute

- 3) Click the "Execution" button to enable the online module change.
(The table below indicates the communication status of the module to be replaced online when the screen below is displayed.)

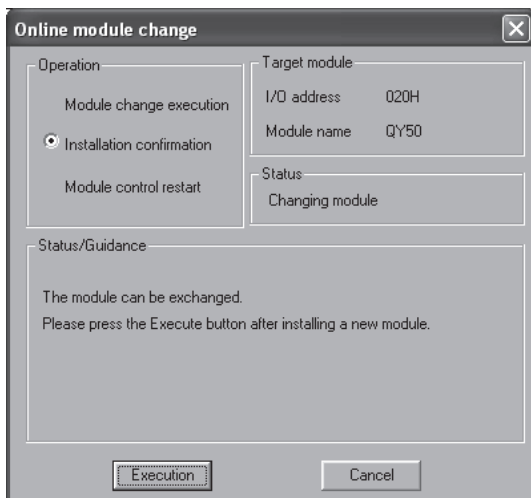

Target modules and items	Execute/not execute
Input module refreshing	Not execute (data are held)
Output module refreshing	Not execute
I/O combined module	
Input refreshing	Not execute (data are held)
Output refreshing	Not execute
Intelligent function module	
Input refreshing	Not execute
Output refreshing	Not execute
Intelligent module automatic refreshing	No processing
Buffer memory batch monitoring	Communication error

- 4) Disconnect the connection of the module (I/O signal) with the external device by the switch and so on.
- 5) Turn off the switch of the external power supply for modules to shut off power supply.
- 6) Remove the terminal block or connector from the module.
- 7) Remove the module.
- 8) Mount a new module in the same slot.
- 9) Mount the terminal block or connector to the module.
- 10) Turn on the switch of the external power supply for modules to resume power supply.

- 11) Connect between the external device and module (I/O signal) by the switch and so on.
- 12) Mount the module, and then click the "Execution" button.
(The table below lists the communication status of the new module when the screen below is displayed.)

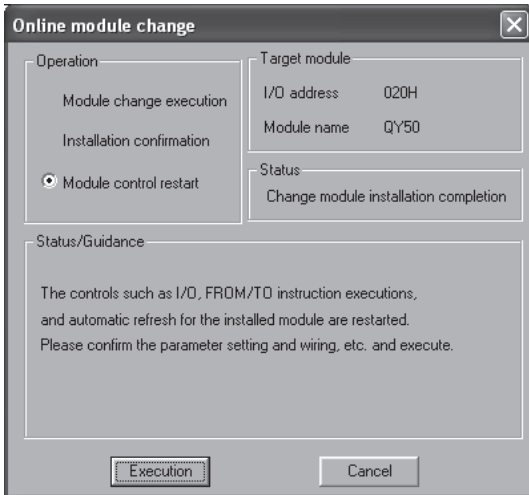

Target modules and items	Execute/not execute
Input module refreshing	Not execute (data are retained)
Output module refreshing	Not execute
I/O combined module	
Input refreshing	Not execute (data are retained)
Output refreshing	Not execute
Intelligent function module	
Input refreshing	Execute
Output refreshing	Execute
Intelligent module automatic refreshing	No processing
Buffer memory batch monitoring	Execute

*: If the initial settings of the intelligent function module have been made by GX Configurator, the setting data are written in to the intelligent function module.

- 13) Click the "Execution" button to start control.
- 14) The "Online module change completed." screen is displayed.
(The table below lists the communication status of the new module when the screen below is displayed.)



Applicable modules and items	Execute/not execute
Input module refreshing	Execute
Output module refreshing	Execute
I/O combined module	
Input refreshing	Execute
Output refreshing	Execute
Intelligent function module	
Input refreshing	Execute
Output refreshing	Execute
Intelligent module automatic refreshing	Execute
Buffer memory batch monitoring	Execute

3.3 Link Data Send/Receive Processing Time Specifications

The following introduces the method of calculating link data send/receive and transmission delay time in the remote I/O network.

3.3.1 Link data send/receive processing

(1) Summary of send/receive processing

Cyclic transmission of the remote I/O network communicates by network module LX/LY/LB/LW.

(a) For input module

The following is an example of CPU module side output (Y).

- 1) Remote master station Y1000 is on.
- 2) Y1000 data is stored in the master module refresh data storage area (LY) by link refresh.
- 3) The Y1000 data in the refresh data storage area (LY) is stored as Y0 in the link data storage area (LY) according to the common parameters.
- 4) The Y0 data in the link data storage area (LY) is stored in the link data storage area (LY) for the remote I/O module by link scan.
- 5) The Y0 data in link data storage area (Y) is stored in refresh data storage area (LY).
- 6) The Y0 data is output from the output module of the remote I/O station by the I/O refresh operation of the remote I/O module.

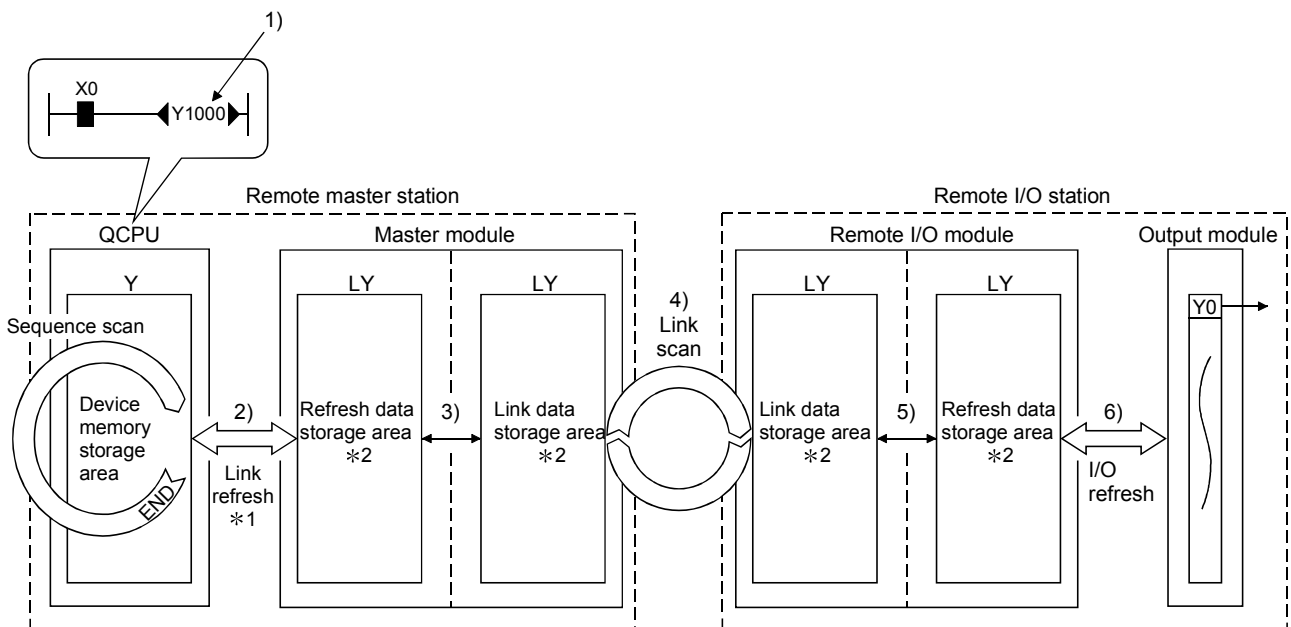

*1: Set by network refresh parameters.
 *2: Set by remote master station common parameters.

(b) For intelligent function module

The following provides an example of how the link device (W) on the CPU module side is sent to an intelligent function module.

- 1) Data is sent to the remote master station W0.
- 2) W0 data is stored in the master module refresh data storage area (LW) by link refresh.
- 3) The W0 data in the refresh data storage area (LW) is stored as W0 in the link data storage area (LW) according to the common parameters.
- 4) The W0 data in the link data storage area (LW) is stored in the link data storage area (LW) for the remote I/O module by link scan.
- 5) The W0 data in link data storage area (LW) is stored in refresh data storage area (LW).
- 6) The W0 data is written to the remote I/O station intelligent function module buffer memory address 0 by the automatic refresh settings of the intelligent function module parameters.

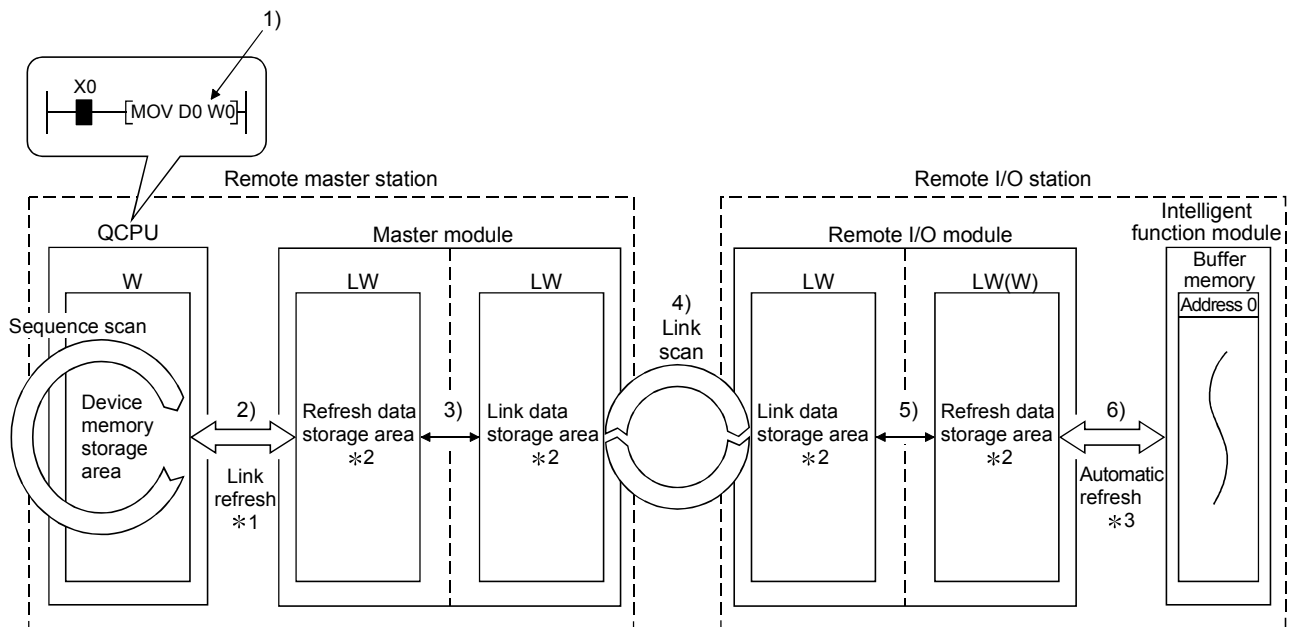

*1: Set by network refresh parameters.
 *2: Set by remote master station common parameters.
 *3: Set by intelligent function module parameter automatic refresh settings.

(2) Link refresh, link scan, I/O refresh and automatic refresh

(a) Link refresh of the remote master station

Link refresh of the remote master station is performed in the END processing of the CPU module.

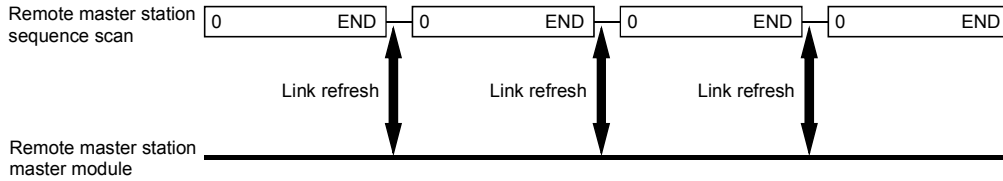

POINT

If latch device (listed in "Device set in PLC side" in the following table) data is cleared to "0" using a sequence program when the CPU module is powered off and on or is exited from the RESET status, the latch data may be output depending on the timing of link scan and link refresh.

To prevent this, perform the operation described in "How to disable the link refresh" in the following table.

Device set in PLC side	How to disable the link refresh
Latch relay (L)	Clear the value of the device to 0 by using device initial value ^(*1) .
File register (R, ZR)	
Extended data register (D) (Universal model QCPU only)	Clear all latch range settings.
Extended link register (W) (Universal model QCPU only)	
Devices within the latch range	

*1: For details on the setting of device initial value, refer to the user's manual (Function Explanation, Program Fundamentals) for the CPU module used.

(b) Link scan

Link scans can be performed synchronously with sequence scans of the CPU module (END synchronization) or asynchronously with them (END asynchronization).

Select END synchronization or END asynchronization, referring to the following.

POINT
To set the END asynchronization, use the following master module and GX Developer. • Master module: First five digits of serial No. are "09012" or later. • GX Developer: GX Developer Version 8.45X or later

1) END synchronization (Default)

The transmission delay time for output can be reduced.

When a sequence scan takes much longer than a link scan, however, the transmission delay time for input is increased. (Refer to Section 3.3.2.)

2) END asynchronization

When a sequence scan takes much longer than a link scan, the transmission delay time for input can be reduced.

However, the transmission delay time for output will be increased. (Refer to Section 3.3.2.)

(c) I/O refresh and automatic refresh

These refreshes are performed in synchronization with link scans.

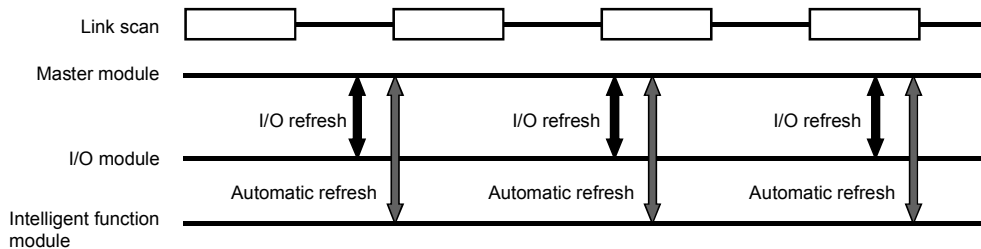

(3) Link data when communication error station/communication stop station has occurred

If a data link communication error or communication stop occurs on a remote I/O station, the master station holds the data (X, B, W) received from the remote I/O station immediately before the error.

The remote I/O station output (Y) is set to all points off.

(A communication stop station is a station that has had its cyclic transmission stopped by peripheral equipment.)

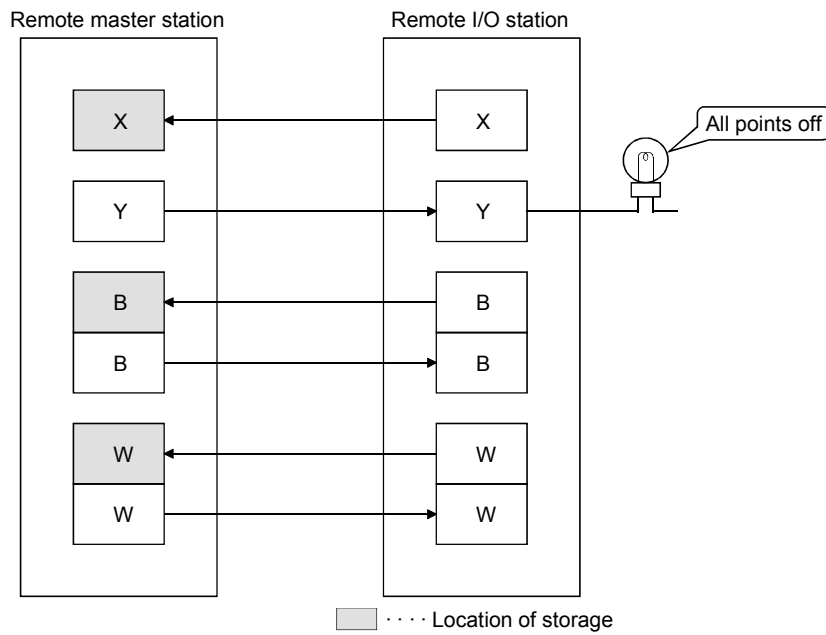

(4) SB/SW when a communication error station/communication stop station occurs on the network

The status of whether there are any communication error/communication stop stations on the network can be checked with the link special relay/register (SB/SW).

Use them as interlocks for programs.

Link special relays and registers

Link special relay/register	Description	Signal status	
		Off	On
SB0047	Shows the baton pass execution status of the host.	The baton pass is being executed	The baton pass is stopped
SB0049	Shows the data link status of the host.	Normal	Abnormal
SB0070	Shows the baton pass execution status of all stations (including the host). However, it only shows the status for the number of stations set with parameters.	The baton pass is being executed on all stations	Occurrence of communication stop station
SW0070 to 0073	Shows the baton pass execution status of each station. Each bit corresponds to the status of each station.	The baton pass is being executed	The baton pass is stopped
SB0074	Shows the cyclic transmission status of all stations (including the host). However, it only shows the status for the number of stations set with parameters.	All stations normal	Occurrence of abnormal station
SW0074 to 0077	Shows the cyclic transmission status of each station. Each bit corresponds to the status of each station.	Normal	Abnormal

3.3.2 Transmission delay time

The names of items (1), (2) on the following pages indicate those between the following stations.

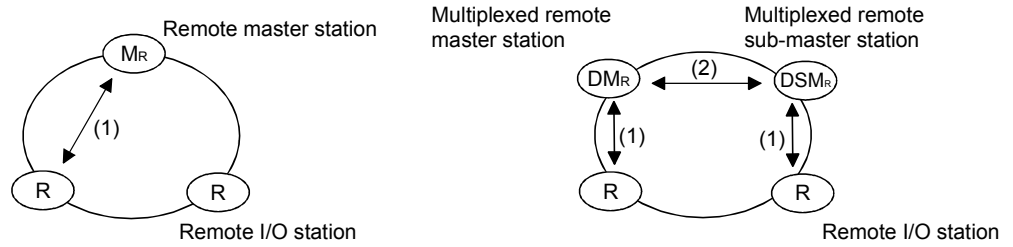

Item Name
(1) Remote master station ↔ remote I/O station
(2) Multiplexed remote master station ↔ multiplexed remote sub-master station

(1) Remote master station ↔ remote I/O station

(a) Cyclic transmission (X/Y/W periodic communication)

Transmission delay time of X/Y/W is the sum of the following.

- Remote master station scan time (Except for the link refreshing time)
- Remote master station link refresh time
- Link scan time
- Remote I/O station I/O refresh (X/Y) or automatic refresh (W)

Calculate the sum as shown below:

(Note that for X/Y communication time, it is necessary to add the I/O module response delay time to the calculation)

1) In the case of END synchronization

[X transmission delay time (T_{DX})] (END synchronization)

[Remote master station scan time (S_m) > link scan time (LS)]

$$T_{DX} = (S_m + \alpha m) \times 2 + S_m + T_{RIOR} \text{ [ms]}$$

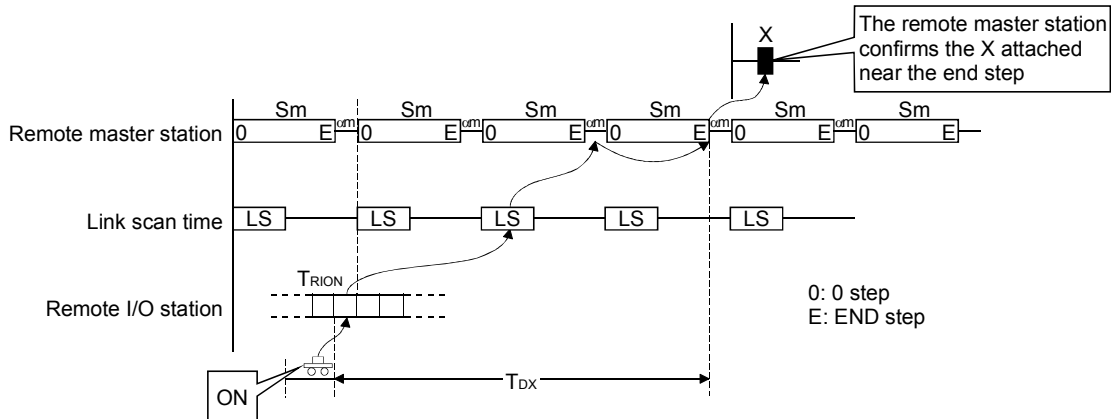

[Remote master station scan time (S_m) < link scan time (LS)]

$$T_{DX} = (S_m + \alpha m) \times \text{round up} [LS / (S_m + \alpha m)] \times 2 + S_m + T_{RIOR} \text{ [ms]}$$

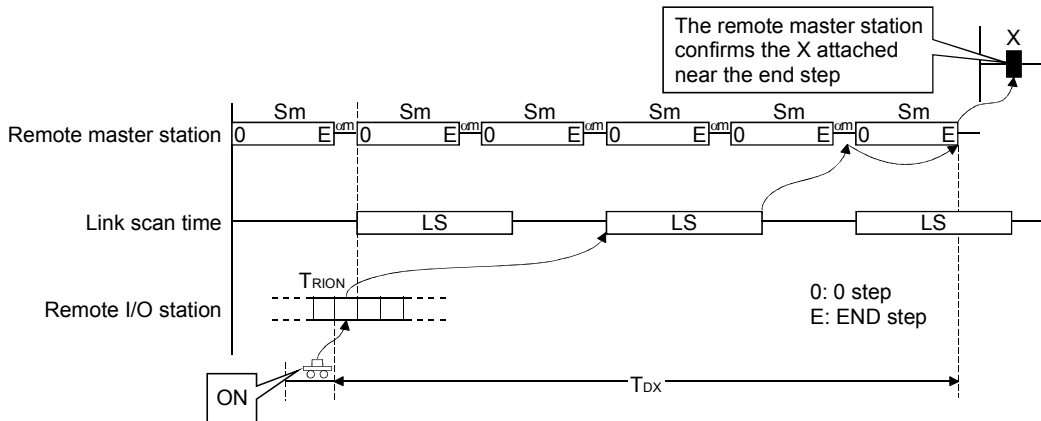

- S_m : Remote master station scan time
- αm : Remote master station link refresh time
- LS : Link scan time
- T_{RIOR} : I/O refresh time
- round up : Round up the decimal point of the result operation $[LS / (S_m + \alpha m)]$

POINT

The same formula is used to calculate the transmission delay time (T_{DX}) independently of the Block send/receive data assurance per station setting.

[Y transmission delay time (T_{DY})] (END synchronization)

[Remote master station scan time (S_m) > link scan time (LS)]

$$T_{DY} = (S_m + \alpha_m) + LS + T_{RIOR} \text{ [ms]}$$

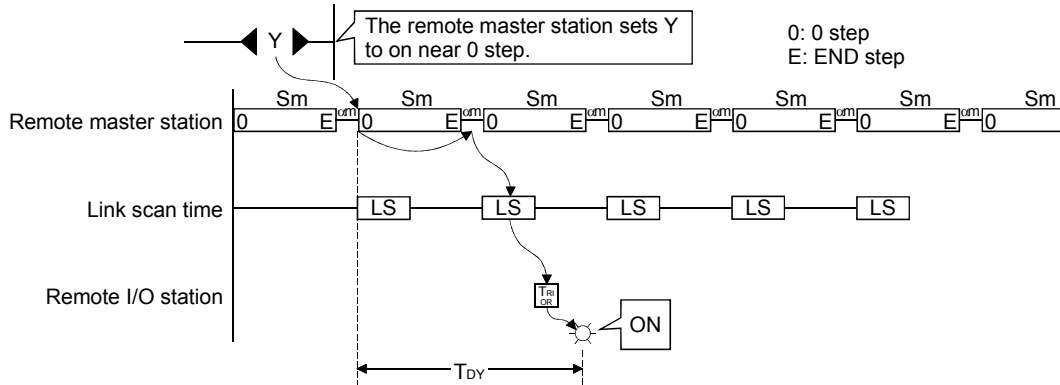

[Remote master station scan time (S_m) < link scan time (LS)]

$$T_{DY} = (S_m + \alpha_m) \times \text{round up} [LS / (S_m + \alpha_m)] + LS + T_{RIOR} \text{ [ms]}$$

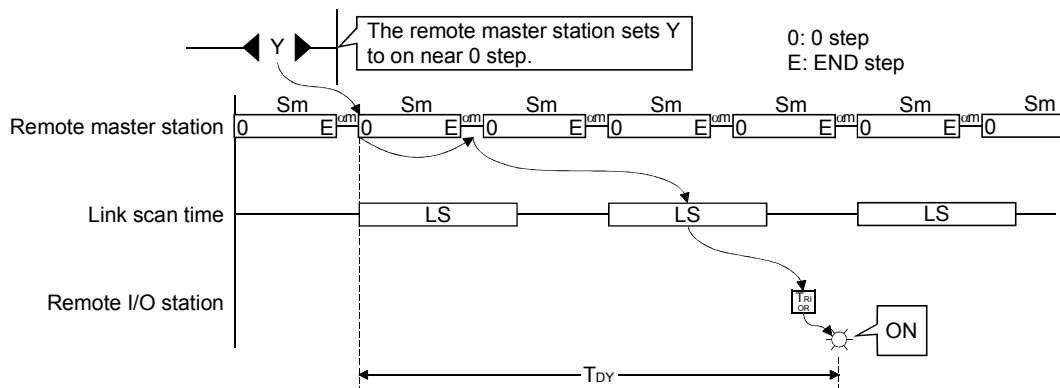

- S_m : Remote master station scan time
- α_m : Remote master station link refresh time
- LS : Link scan time
- T_{RIOR} : I/O refresh time
- round up : Round up the decimal point of the result operation $[LS / (S_m + \alpha_m)]$

POINT

When the "Block send/receive data assurance per station" box is checked, the transmission delay time (T_{DY}) is calculated as follows:

- [Remote master station scan time (S_m) > Link scan time (LS)]
 $T_{DY} = (S_m + \alpha_m) + LS + T_{RIOR} \text{ [ms]}$
- [Remote master station scan time (S_m) < Link scan time (LS)]
 $T_{DY} = (S_m + \alpha_m) \times \text{round up} [LS / (S_m + \alpha_m)] \times 2 + LS + T_{RIOR} \text{ [ms]}$

[W output transmission delay time (T_{DB2})] (END synchronization)

[Remote master station scan time (S_m) > link scan time (LS)]

$$T_{DB2} = (S_m + \alpha_m) + LS + T_{RBF} \text{ [ms]}$$

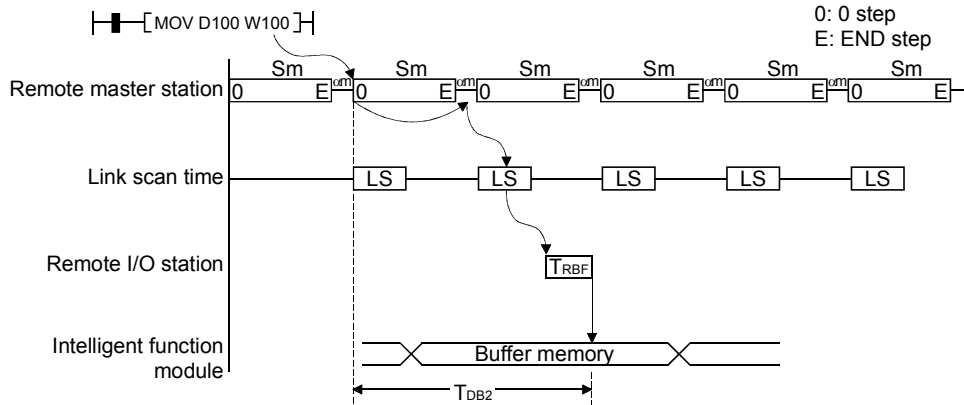

[Remote master station scan time (S_m) < link scan time (LS)]

$$T_{DB2} = (S_m + \alpha_m) \times \text{round up} [LS / (S_m + \alpha_m)] + LS + T_{RBF} \text{ [ms]}$$

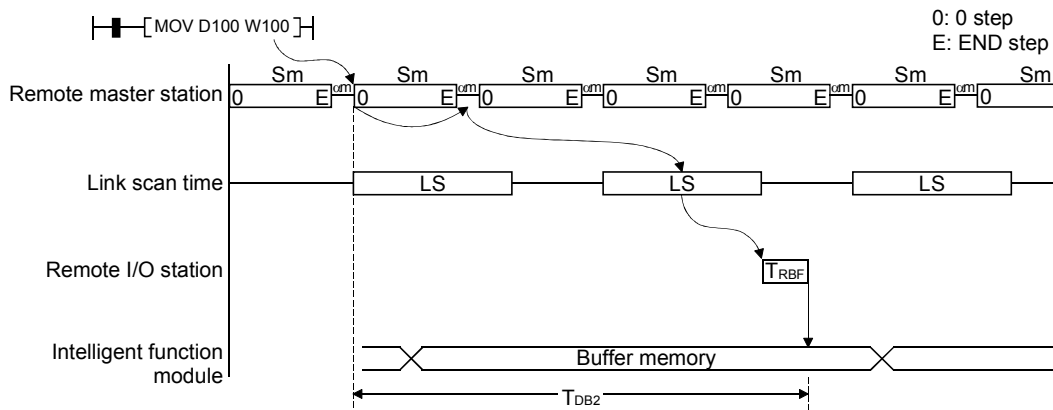

- S_m : Remote master station scan time
- α_m : Remote master station link refresh time
- LS : Link scan time
- T_{RBF} : Intelligent function module buffer memory refresh time
- round up : Round up the decimal point of the result operation [$LS / (S_m + \alpha_m)$]

POINT

When the "Block send/receive data assurance per station" box is checked, the transmission delay time (T_{DB2}) is calculated as follows:

- [Remote master station scan time (S_m) > Link scan time (LS)]
 $T_{DB2} = (S_m + \alpha_m) + LS + T_{RBF} \text{ [ms]}$
- [Remote master station scan time (S_m) < Link scan time (LS)]
 $T_{DB2} = (S_m + \alpha_m) \times \text{round up}[LS / (S_m + \alpha_m)] \times 2 + LS + T_{RBF} \text{ [ms]}$

2) In the case of END asynchronization

[X transmission delay time (T_{DX})] (END asynchronization)

[Remote master station scan time (S_m) > link scan time (LS)]

$$T_{DX} = S_m + \alpha_m + S_m + T_{RIOR} \text{ [ms]}$$

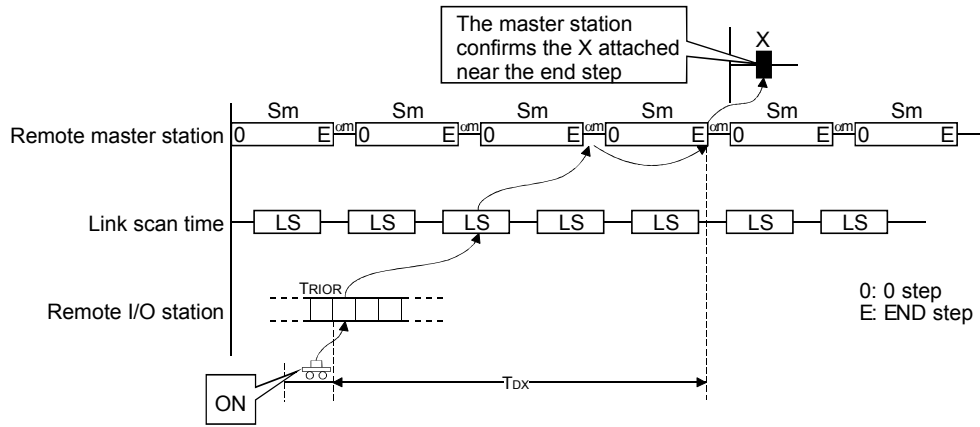

[Remote master station scan time (S_m) < link scan time (LS)]

$$T_{DX} = LS \times 2 + S_m + \alpha_m + S_m + T_{RIOR} \text{ [ms]}$$

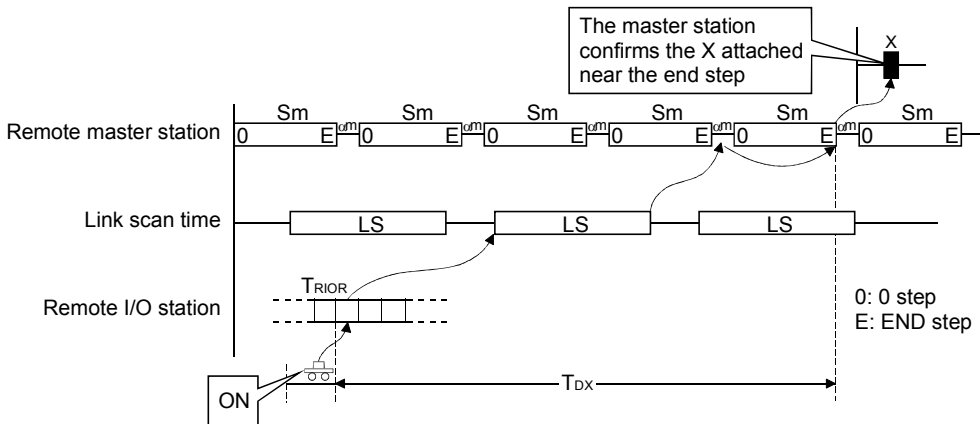

- S_m : Remote master station scan time
- α_m : Remote master station link refresh time
- LS : Link scan time
- T_{RIOR} : I/O refresh time

POINT

When the "Block send/receive data assurance per station" box is checked, the transmission delay time (T_{DX}) is calculated as follows:

- Remote master station scan time (S_m) > Link scan time (LS)

$$T_{DX} = (S_m + \alpha_m) \times 2 + S_m + T_{RIOR} + LS \text{ [ms]}$$

- Remote master station scan time (S_m) < Link scan time (LS)

$$T_{DX} = LS \times 3 + S_m + \alpha_m + S_m + T_{RIOR} \text{ [ms]}$$

[Y transmission delay time (T_{DY})] (END asynchronization)

[Remote master station scan time (S_m) > link scan time (LS)]

$$T_{DY} = (S_m + \alpha m) + LS \times 2 + T_{RIOR} \text{ [ms]}$$

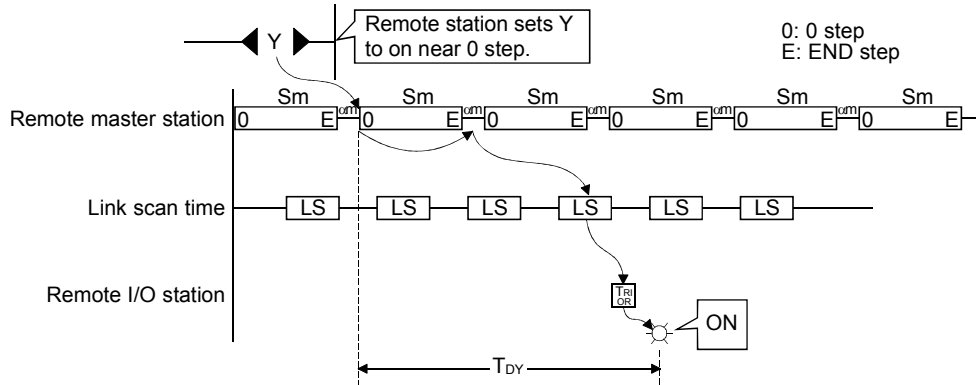

[Remote master station scan time (S_m) < link scan time (LS)]

$$T_{DY} = (S_m + \alpha m) + LS \times 2 + T_{RIOR} \text{ [ms]}$$

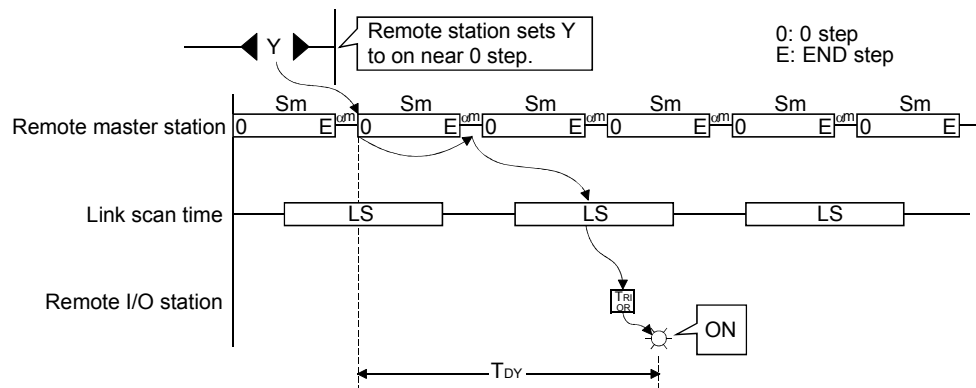

- S_m : Remote master station scan time
- αm : Remote master station link refresh time
- LS : Link scan time
- T_{RIOR} : I/O refresh time

POINT

When the "Block send/receive data assurance per station" box is checked, the transmission delay time (T_{DY}) is calculated as follows:

- Remote master station scan time (S_m) > Link scan time (LS)

$$T_{DY} = (S_m + \alpha m) \times 2 + LS \times 2 + T_{RIOR} \text{ [ms]}$$

- Remote master station scan time (S_m) < Link scan time (LS)

$$T_{DY} = (S_m + \alpha m) + LS \times 3 + T_{RIOR} \text{ [ms]}$$

[W input transmission delay time (T_{DB1})] (END asynchronization)

[Remote master station scan time (S_m) > link scan time (LS)]

$$T_{DB1} = S_m + \alpha m + S_m + T_{RBF} \text{ [ms]}$$

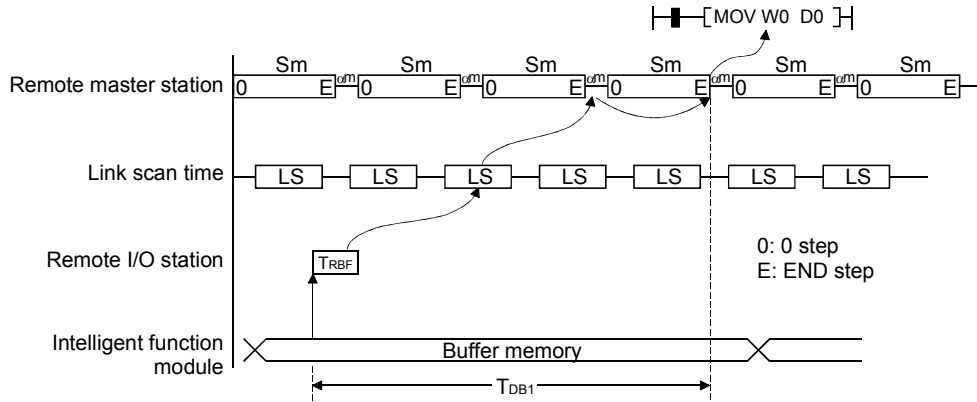

[Remote master station scan time (S_m) < link scan time (LS)]

$$T_{DB1} = LS \times 2 + S_m + \alpha m + S_m + T_{RBF} \text{ [ms]}$$

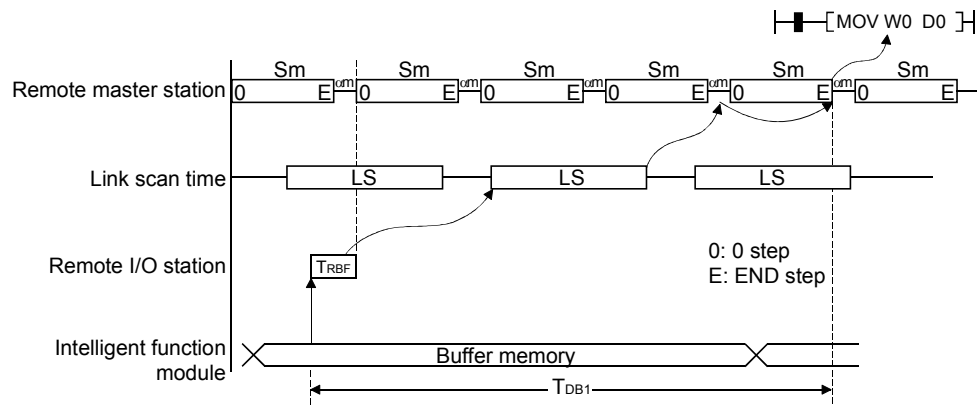

- S_m : Remote master station scan time
- αm : Remote master station link refresh time
- LS : Link scan time
- T_{RBF} : Intelligent function module buffer memory refresh time

POINT

When the "Block send/receive data assurance per station" box is checked, the transmission delay time (T_{DB1}) is calculated as follows:

- Remote master station scan time (S_m) > Link scan time

$$T_{DB1} = (S_m + \alpha m) \times 2 + S_m + T_{RBF} + LS \text{ [ms]}$$

- Remote master station scan time (S_m) < Link scan time

$$T_{DB1} = LS \times 3 + S_m + \alpha m + S_m + T_{RBF} \text{ [ms]}$$

[W output transmission delay time (T_{DB2})] (END asynchronization)

[Remote master station scan time (S_m) > link scan time (LS)]

$$T_{DB2} = (S_m + \alpha m) + LS \times 2 + T_{RBF} \text{ [ms]}$$

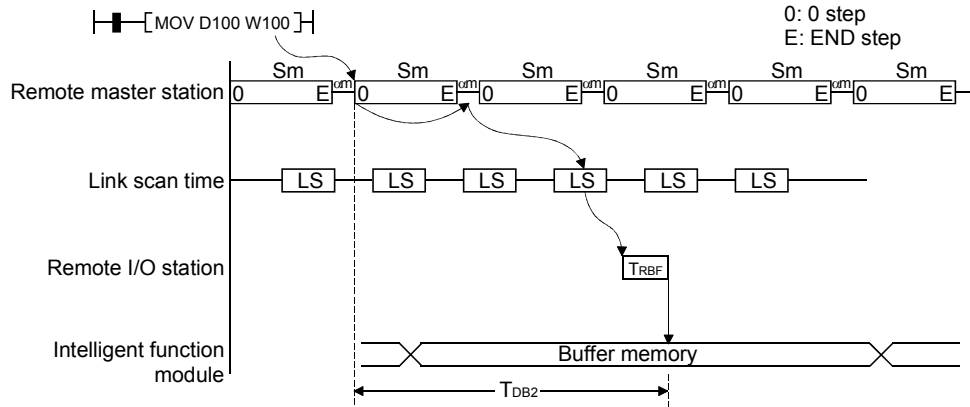

[Remote master station scan time (S_m) < link scan time (LS)]

$$T_{DB2} = (S_m + \alpha m) + LS \times 2 + T_{RBF} \text{ [ms]}$$

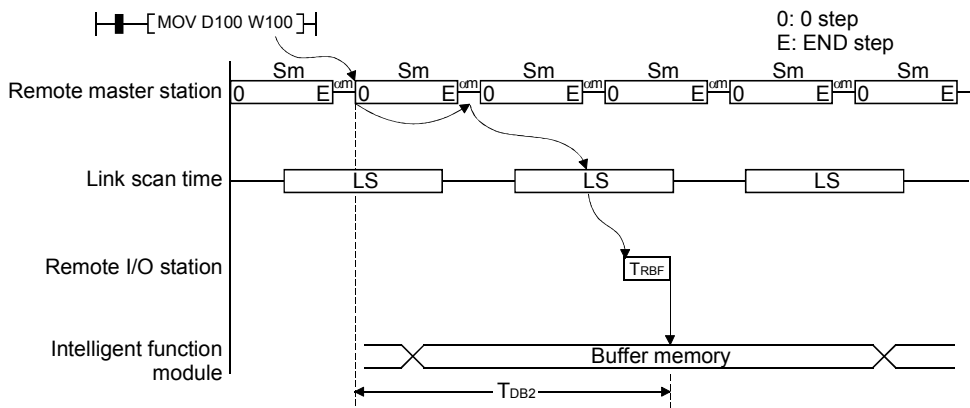

- S_m : Remote master station scan time
- αm : Remote master station link refresh time
- LS : Link scan time
- T_{RBF} : Intelligent function module buffer memory refresh time

POINT

When the "Block send/receive data assurance per station" box is checked, the transmission delay time (T_{DB1}) is calculated as follows:

- Remote master station scan time (S_m) > Link scan time (LS)

$$T_{DB2} = (S_m + \alpha m) \times 2 + LS \times 2 + T_{RBF} \text{ [ms]}$$

- Remote master station scan time (S_m) < Link scan time (LS)

$$T_{DB2} = (S_m + \alpha m) + LS \times 3 + T_{RBF} \text{ [ms]}$$

- (b) REMFR/REMTO/READ/WRITE instructions
 REMFR/REMTO/READ/WRITE instructions transmission delay time is the sum of the following.
- Remote master station scan time (Except for the link refreshing time)
 - Remote master station refresh time
 - Link scan time
- Calculate the sum as shown below:

[Instruction transmission delay time (M_D)]

[Remote master station scan time (S_m) > link scan time (LS)]
 $M_D = (S_m + \alpha m) \times 3$ [ms]

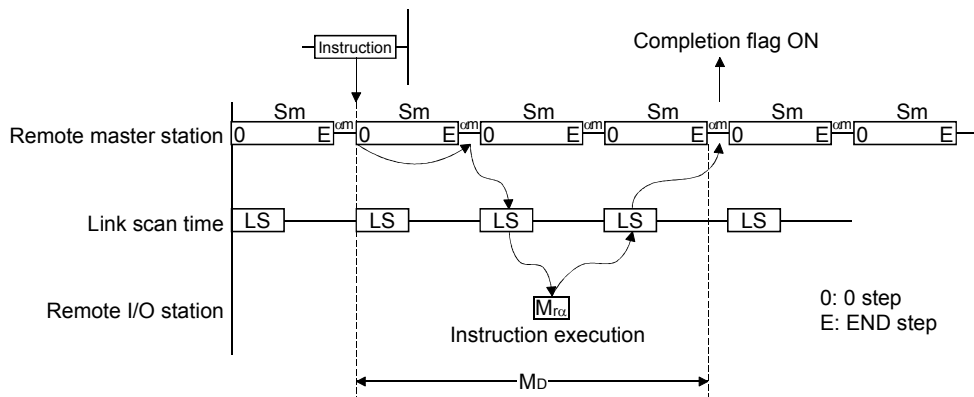

[Remote master station scan time (S_m) < link scan time (LS)]
 $M_D = (S_m + \alpha m) \times \text{round up} [LS / (S_m + \alpha m)] \times 3$ [ms]

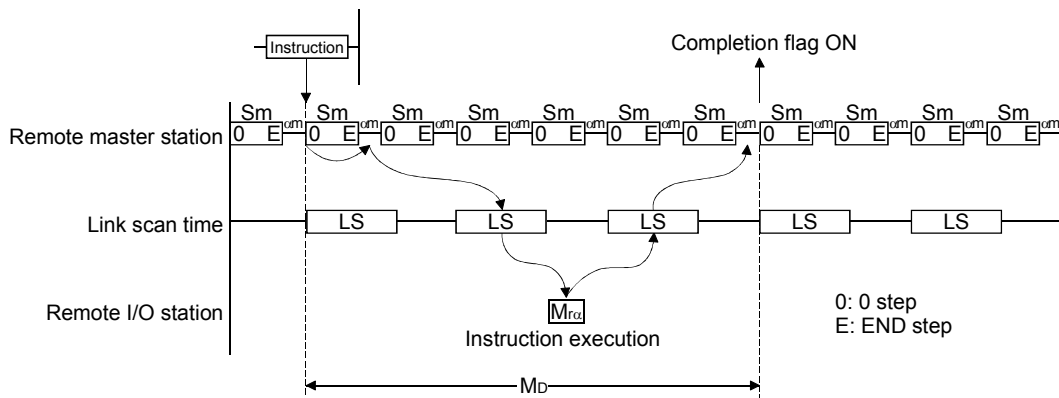

- S_m : Remote master station scan time
- αm : Remote master station link refresh time
- LS : Link scan time
- $M_{r\alpha}$: Instruction access data refresh time
- round up : Round up the decimal point of the result operation $[LS / (S_m + \alpha m)]$

(2) Multiplexed remote master station ↔ multiplexed remote sub-master station

(a) Cyclic transmission (LB/LW/LX/LY periodic communication)

The transmission delay time of B/W/Y communication is the sum of the following:

- Scan times of a multiplexed remote master station and a multiplexed remote sub-master station (Except for the link refreshing time)
- Link refresh times of a multiplexed remote master station and a multiplexed remote sub-master station
- Link scan time of a multiplexed remote master station

Calculate the sum as below:

1) In the case of END synchronization

[Transmission delay time of B/W/Y communication] (END synchronization)

1) Multiplexed remote master station → Multiplexed remote sub-master station:

Transmission delay time (T_{DM1})

[Multiplexed remote master station side scan time (S_m) > Link scan time (LS)]

$$T_{DM1} = (S_m + \alpha m) + LS + (S_s \times 2 + \alpha s) \text{ [ms]}$$

[Multiplexed remote master station side scan time (S_m) < Link scan time (LS)]

$$T_{DM1} = (S_m + \alpha m) \times \text{round up } [LS/(S_m + \alpha m)] + LS + (S_s \times 2 + \alpha s) \text{ [ms]}$$

2) Multiplexed remote sub-master station → Multiplexed remote master station:

Transmission delay time (T_{DS1})

[Multiplexed remote master station side scan time (S_m) > Link scan time (LS)]

$$T_{DS1} = (S_s + \alpha s) + (S_m + \alpha m) \times 2 + S_m \text{ [ms]}$$

[Multiplexed remote master station side scan time (S_m) < Link scan time (LS)]

$$T_{DS1} = (S_s + \alpha s) + (S_m + \alpha m) \times \text{round up } [LS/(S_m + \alpha m)] \times 2 + S_m \text{ [ms]}$$

S_m : Multiplexed remote master station side scan time

S_s : Multiplexed remote sub-master station side scan time

αm : Multiplexed remote master station side link refresh time

αs : Multiplexed remote sub-master station side link refresh time

LS : Link scan time

round up : Round up decimal fraction of the operation result
[$LS/(S_m + \alpha m)$]

The above calculations are effective under the following conditions:

- There are no faulty stations.
- Transient transmission is not executed.

POINT

When the Block send/receive data assurance per station setting is enabled, the following formulas are used.

1) Formula for Transmission delay time (T_{DM1})

[Multiplexed remote master station side scan time (S_m) > Link scan time (LS)]

$$T_{DM1} = (S_m + \alpha m) + LS + (S_s \times 2 + \alpha s) \text{ [ms]}$$

[Multiplexed remote master station side scan time (S_m) < Link scan time (LS)]

$$T_{DM1} = (S_m + \alpha m) \times \text{round up}[LS/(S_m + \alpha m)] \times 2 + LS + (S_s \times 2 + \alpha s) \text{ [ms]}$$

2) Formula for Transmission delay time (T_{DS1})

The same formula is used independently of the Block send/receive data assurance per station setting.

2) In the case of END asynchronization

[Transmission delay time of B/W/Y communication] (END asynchronization)

- 1) Multiplexed remote master station → Multiplexed remote sub-master station:
 Transmission delay time (T_{DM1})
 [Multiplexed remote master station side scan time (S_m) > Link scan time (LS)]
 $T_{DM1} = S_m + \alpha_m + LS + (S_s + \alpha_s) \times 2$ [ms]
- [Multiplexed remote master station side scan time (S_m) < Link scan time (LS)]
 $T_{DM1} = S_m + \alpha_m + LS + (S_s + \alpha_s) \times 2$ [ms]
- 2) Multiplexed remote sub-master station → Multiplexed remote master station:
 Transmission delay time (T_{DS1})
 [Multiplexed remote master station side scan time (S_m) > Link scan time (LS)]
 $T_{DS1} = S_s + \alpha_s + LS + (S_m + \alpha_m) \times 2$ [ms]
- [Multiplexed remote master station side scan time (S_m) < Link scan time (LS)]
 $T_{DS1} = S_s + \alpha_s + LS + (S_m + \alpha_m) \times 2$ [ms]

S_m : Multiplexed remote master station side scan time
 S_s : Multiplexed remote sub-master station side scan time
 α_m : Multiplexed remote master station side link refresh time
 α_s : Multiplexed remote sub-master station side link refresh time
 LS : Link scan time

The above calculations are effective under the following conditions:

- There are no faulty stations.
- Transient transmission is not executed.

POINT

When the block send/receive data assurance per station setting is enabled, the following formulas are used.

- 1) Formula for Transmission delay time (T_{DM1})
 [Multiplexed remote master station side scan time (S_m) > Link scan time (LS)]
 $T_{DM1} = (S_m + \alpha_m) \times 2 + LS + (S_s + \alpha_s) \times 2$ [ms]
- [Multiplexed remote master station side scan time (S_m) < Link scan time (LS)]
 $T_{DM1} = S_m + \alpha_m + LS \times 2 + (S_s + \alpha_s) \times 2$ [ms]
- 2) Formula for Transmission delay time (T_{DS1})
 [Multiplexed remote master station side scan time (S_m) > Link scan time (LS)]
 $T_{DS1} = S_s + \alpha_s + LS + (S_m + \alpha_m) \times 3$ [ms]
- [Multiplexed remote master station side scan time (S_m) < Link scan time (LS)]
 $T_{DS1} = S_s + \alpha_s + LS \times 2 + (S_m + \alpha_m) \times 2$ [ms]

- (b) SEND/RECV/RECVS/READ/WRITE/REQ/ZNRD/ZNWR instruction communication

The transmission delay time of instruction communication is the sum of the following:

- Scan times of a multiplexed remote master station and a multiplexed remote sub-master station (Except for the link refreshing time)
- Link refresh times of a multiplexed remote master station and a multiplexed remote sub-master station
- Link scan time of a multiplexed remote master station

Calculate the sum as below:

[Transmission delay times of instruction communication]

- 1) SEND (with arrival check)/READ/WRITE/REQ/ZNRD/ZNWR instruction

$$T_{D2} = (S_T + \alpha T + S_R + \alpha R) \times 2 + (LS \times 4) + LS_u \text{ [ms]}$$

$$\text{(MAX : } T_{D2} = (S_T + \alpha T + S_R + \alpha R) \times 2 + (LS \times 6) + LS_u)$$

- 2) SEND - RECV arrival time

$$T_{D3} = S_T + \alpha T + (LS \times 2) + (S_R \times 2) + \alpha R + LS_u \text{ [ms]}$$

$$\text{(MAX : } T_{D3} = S_T + \alpha T + (LS \times 3) + (S_R \times 2) + \alpha R + LS_u)$$

- 3) SEND - RECVS arrival time

$$T_{D4} = S_T + \alpha T + (LS \times 2) + S_R + \alpha R + LS_u \text{ [ms]}$$

$$\text{(MAX : } T_{D4} = S_T + \alpha T + (LS \times 3) + S_R + \alpha R + LS_u)$$

S_T : Send side scan time

S_R : Receive side scan time

αT : Send side link refresh time *2

αR : Receive side link refresh time *2

LS : Link scan time

$$LS_u = \left\{ \left(\frac{\text{Number of simultaneous transient requests}}{\text{Maximum transient count}} \right)^{*1} - 1 \right\} \times (LS \times 2)$$

Number of simultaneous transient requests : Total number of transient requests made from stations on the same network during one link scan

Maximum transient count : Max. transient count during one link scan set by supplementary settings of common parameters

*1: Round up the fractional portion

*2: Total number of mounted network modules

(3) Link refresh time

The link refresh time (CPU module end processing time extension) is calculated as shown below.

- Link device assignment points
- Type of CPU used

[Remote master station link refresh time (α_m)]

$$\alpha_m = KM1 + KM2 \times \left[\frac{LB + LX + LY + SB}{16} + LW + SW \right] + \alpha_E \text{ [ms]}$$

$$\alpha_E = KM3 \times \left[\frac{LB + LX + LY}{16} + LW \right]$$

- α_m : Remote master station link refresh time
- LB : Total points of link relays (LB) refreshed by the corresponding station *1
- LW : Total points of link registers (LW) refreshed by the corresponding station *1
- LX : Total points of link inputs (LX) refreshed by the corresponding station *1
- LY : Total points of link outputs (LY) refreshed by the corresponding station *1
- SB : Number of points of the link special relay (SB)
- SW : Number of points of the link special register (SW)
- α_E : Transfer time of the file registers (R, ZR), extended data register (D), and extended link register (W) on the memory card *2

KM1, KM2, KM3 : Constants

*1: Total points are the sum of link devices set in the link refresh parameter settings and in the network range settings. The points assigned for reserved station are not included.

*2: Add α_E when the data are refreshed to a file register in a memory card. Do not add α_E if the data are refreshed to a file register in a standard RAM or extended SRAM cassette.

(a) When a master module is connected to main base unit

Constant		KM1	KM2 ($\times 10^{-3}$)	KM3 ($\times 10^{-3}$)
High Performance model QCPU	Q02CPU	0.30	0.48	0.47
	Other than above	0.13	0.41	0.33
Process CPU				
Redundant CPU				
Universal model QCPU	Q00UJ/Q00U/Q01UCPU	0.16	0.41	—
	Q02UCPU	0.16	0.41	0.39
	Q03UD/Q03UDECPU	0.09	0.41	0.39
	Other than above	0.09	0.41	0.33

(b) When a master module is connected to extension base unit

CPU type		Constant	KM1	KM2 ($\times 10^{-3}$)	KM3 ($\times 10^{-3}$)
		High Performance model QCPU	Q02CPU	0.30	1.20
	Other than above	0.13	0.97	0.53	
Process CPU		0.13	0.97	0.53	
Redundant CPU					
Universal model QCPU	Q00UJ/Q00U/Q01UCPU	0.16	1.06	—	
	Q02UCPU	0.16	1.06	0.39	
	Q03UD/Q03UDECPU	0.09	0.97	0.39	
	Other than above	0.09	0.97	0.33	

POINT

The values in previous page are calculated on the basis that data are received from all stations during one sequence scan.
 When the link scan is long or when the sequence scan is short, data from all stations may not be received within one sequence scan.
 If this occurs, the actual link refresh time is less than the calculated value shown in this section.

Remote I/O station link refresh time (αr)

The remote I/O station link refresh time (αr) does not affect transmission delay time.

(4) Link scan time

Link scan time is based on a calculation of the following factors.

- Link device assignment points
- Number of stations connected

[Link scan time]

[Communication speed: 10 Mbps]

$$LS = KB + (0.45 \times \text{total number of stations}) + \{LX + LY + LB + (LW \times 16)\} / 8 \times 0.001 + KR$$

$$+ \{LY_{M \rightarrow R} + LB_{M \rightarrow R} + (LW_{M \rightarrow R} \times 16)\} / 16 \times 0.0003$$

$$+ \{LX_{M \leftarrow R} + LB_{M \leftarrow R} + (LW_{M \leftarrow R} \times 16)\} / 16 \times 0.0003$$

$$+ (T \times 0.001) + (F \times 4) \text{ [ms]}$$

[Communication speed: 25 Mbps]

$$LS = KB + (0.40 \times \text{total number of stations}) + \{LX + LY + LB + (LW \times 16)\} / 8 \times 0.0004 + KR$$

$$+ \{LY_{M \rightarrow R} + LB_{M \rightarrow R} + (LW_{M \rightarrow R} \times 16)\} / 16 \times 0.0003$$

$$+ \{LX_{M \leftarrow R} + LB_{M \leftarrow R} + (LW_{M \leftarrow R} \times 16)\} / 16 \times 0.0003$$

$$+ (T \times 0.0004) + (F \times 4) \text{ [ms]}$$

LS : Link scan time

KB, KR : constants

Total remote I/O stations	1 to 8	9 to 16	17 to 24	25 to 32	33 to 40	41 to 48	49 to 56	57 to 64
KB	4.0	4.5	4.9	5.3	5.7	6.2	6.6	7.0
KR	3.9	3.1	2.6	2.3	1.7	1.1	0.6	0.0

LX : Total number of link inputs (LX) being used by all stations. *1

LY : Total number of link outputs (LY) being used by all stations. *1

LB : Total number of link relay (LB) being used by all stations *1

LW : Total number of link register (LW) being used by all stations *1

LY_{M → R} : Total number of link outputs (LY) being used by stations in M → R direction *1

LB_{M → R} : Total number of link relay (LB) being used by stations in M → R direction *1

LW_{M → R} : Total number of link register (LW) being used by stations in M → R direction *1

LX_{M ← R} : Total number of link input (LX) being used by stations in M ← R direction *1

LB_{M ← R} : Total number of link relay (LB) being used by stations in M ← R direction *1

LW_{M ← R} : Total number of link register (LW) being used by stations in M ← R direction *1

T : Maximum number of bytes transmitting during one link scan *2

F : Number of stations that return to system (available only when an error has occurred. Maximum number of stations that return to system in a link scan (setting) *3)

*1: Total link device points set up in Network range assignment.

Note that the points assigned to reserved stations are excluded.

*2: When multiple stations execute transient transmission simultaneously, the value is a total of processing time at each station.

*3: Set the maximum number of stations that return to system in a link scan using the supplementary settings in the common parameters. (Refer to section 5.1.4.)

(5) Refresh time with the remote I/O module, I/O module and intelligent function module

Refresh time with the remote I/O module, I/O module and intelligent function module is according to the formula shown below.

[I/O module and refresh time]

$$T_{RIOR} = X_K/16 \times 0.0016 + X_Z/16 \times 0.0024 + Y_K/16 \times 0.0014 + Y_Z/16 \times 0.0022 \text{ [ms]}$$

T_{RIOR} : I/O refresh time

X_K : Number of input modules mounted to main base unit (Multiples of 16)

X_Z : Number of input modules mounted to extension base unit (Multiples of 16)

Y_K : Number of output modules mounted to main base unit (Multiples of 16)

Y_Z : Number of output modules mounted to extension base unit (Multiples of 16)

The number of I/O modules ranges as follows:

The input module is the X range set by the common parameters of the network parameters

The output module is the range of modules mounted to the remote I/O station (from the first output module mounted to the main base unit to the last output module mounted to the extension base unit.)

In the formula, the main base unit and extension base units from the range referenced above are assigned.

[Intelligent function module and refresh time]

$$T_{RBF} = N_{BF} + N_{CF} N_{DT} + N_{EX} \text{ [ms]}$$

T_{RBF} : Refresh time between intelligent function module and GX Configurator

N_{BF} : Refresh time generated by auto refresh settings of GX Configurator for intelligent function module

$$N_{BF} = (\text{number of set modules} \times 0.05\text{ms}) + (\text{number of set items} \times 0.22\text{ms}) \\ + (\text{number of set words} \times 0.005\text{ms}) \text{ [ms]}$$

N_{CF} : Refresh time generated by CC-Link auto refresh settings of remote I/O station

$$N_{CF} = (\text{number of set modules} \times 3\text{ms}) + (\text{number of set words} \times 0.003\text{ms}) + 1\text{ms} \text{ [ms]}$$

N_{DT} : Refresh time generated by device-to-device transfer parameter settings of remote I/O station

$$N_{DT} = (\text{number of set devices} \times 0.3\text{ms}) + (\text{number of set words} \times 0.006\text{ms}) \text{ [ms]}$$

N_{EX} : Delay time by external access or relay processing *1

$$N_{EX} = 0 \text{ ms or } 20 \text{ ms}$$

*1: In the case of the following access (reading and writing devices, monitoring, etc.) or relay processing, 20 ms is generated as delay time.

Without any access or relay processing, the delay time is 0 ms.

- When accessing a remote I/O station from GX Developer or GOT, or when accessing other station from GX Developer or GOT via a remote I/O station.
- When accessing a remote I/O station from an intelligent function module, or when accessing other station from an intelligent function module via a remote I/O station.
- When accessing a remote I/O station from a CPU module.

(6) Transmission delay time formula

The transmission delay time is calculated based on the following system design and conditions.

(System design, conditions)

- 1) CPU module: Q06HCPU
- 2) Total number of remote I/O stations: 8
- 3) Number of link devices: LX = LY = 1024 points, LB = LW = 0 point, SB = SW = 512 points
- 4) Remote master station CPU module scan time: 1 ms
- 5) Communication speed: 10 Mbps
- 6) File register not used.
- 7) Transient transmission not used.
- 8) Remote master station mounts the master module to the main base unit.
- 9) All remote I/O stations only use the I/O module.
- 10) The link device per each remote I/O station is LX = LY = 128 points.
- 11) Link scans are performed in synchronization with sequence scans.

(END synchronization)

<Constants when a master module is mounted to the main base unit.>

Constant	KM1	KM2 ($\times 10^{-3}$)	KM3 ($\times 10^{-3}$)
CPU type			
Q06HCPU	0.13	0.41	0.53

(a) Link refresh time (αm)

$$\begin{aligned}\alpha m &= KM1 + KM2 \times \{(LB + LX + LY + SB) / 16 + LW + SW\} + \alpha E \\ &= 0.13 + 0.41 \times 10^{-3} \times \{(0 + 1024 + 1024 + 512) / 16 + 0 + 512\} + 0 \\ &= 0.41 \text{ [ms]}\end{aligned}$$

(b) Link scan time (LS)

$$\begin{aligned}LS &= KB + (0.45 \times \text{total number of remote I/O stations}) + \{LX + LY + LB + \\ &\quad (LW \times 16)\} / 8 \times 0.001 + KR + \{LYM \rightarrow R + LBM \rightarrow R + (LWM \rightarrow R \times \\ &\quad 16)\} / 16 \times 0.0003 \\ &\quad + \{LXM \leftarrow R + LBM \leftarrow R + (LWM \leftarrow R \times 16)\} / 16 \times 0.0003 \\ &\quad + (T \times 0.001) + (F \times 4) \\ &= 4.0 + (0.45 \times 8) + \{1024 + 1024 + 0 + (0 \times 16)\} / 8 \times 0.001 + 3.9 \\ &\quad + \{1024 + 0 + (0 \times 16)\} / 16 \times 0.0003 \\ &\quad + \{1024 + 0 + (0 \times 16)\} / 16 \times 0.0003 \\ &\quad + (0 \times 0.001) + (0 \times 4) \\ &= 11.8 \text{ [ms]}\end{aligned}$$

(c) I/O refresh time

$$\begin{aligned}T_{RIOR} &= XK/16 \times 0.0016 + XZ/16 \times 0.0024 + YK/16 \times 0.0014 \\ &\quad + YZ/16 \times 0.0022 \\ &= 128/16 \times 0.0016 + 0 + 128/16 \times 0.0014 + 0 \\ &= 0.024 \text{ [ms]}\end{aligned}$$

(d) Cyclic transmission delay

Since $S_m = 1$ [ms], $LS = 11.8$ [ms], the $S_m < LS$ formula is used.

1) Input transmission delay time (T_{DX})

$$\begin{aligned} T_{DX} &= (S_m + \alpha m) \times \text{round up} [LS / (S_m + \alpha m)] \times 2 + S_m + T_{RIOR} \\ &= (1 + 0.41) \times [11.8 / (1 + 0.41)] \times 2 + 1 + 0.024 \\ &= 24.6 \text{ [ms]} \end{aligned}$$

2) Output transmission delay time (T_{DY})

$$\begin{aligned} T_{DY} &= (S_m + \alpha m) \times \text{round up} [LS / (S_m + \alpha m)] + LS + T_{RIOR} \\ &= (1 + 0.41) \times [11.8 / (1 + 0.41)] + 11.8 + 0.024 \\ &= 23.6 \text{ [ms]} \end{aligned}$$

3.3.3 Switching time from the multiplexed remote master station to the multiplexed remote sub-master station in a multiplexed remote I/O network

In the multiplexed remote I/O network system, the multiplexed remote sub-master station takes over the control of the remote I/O station from the multiplexed remote master station when it develops an error.

While control is switched from the multiplexed remote master station to the multiplexed remote sub-master station, the remote I/O station holds output (data).

The switching time from the multiplexed remote master station to the multiplexed remote sub-master station is expressed with the formula below:

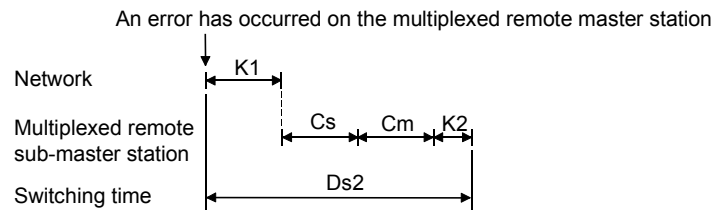

[Switching time from the multiplexed remote master station to the multiplexed remote sub-master station ($Ds2$)]

$$Ds2 = K1 + Cs + Cm \text{ [ms]}$$

K1: Internal processing time

- When a power failure or CPU module stop error occurs: 620ms
- When a system is switched by the following: execution of a system switching instruction, a system switching request by GX Developer, or link cable disconnection on other network modules: 160ms

Cs: Normal station baton passing/cyclic communication initializing time

$$= \text{Number of normal stations} \times 9 \text{ [ms]}$$

Cm: Error station baton passing/cyclic communication initializing time

$$= \text{Number of error stations} \times 16 \text{ [ms]}$$

(only if any error station is found)

3.3.4 Output holding time during system switching in the multiplexed remote I/O network for redundant system

In the multiplexed remote I/O network for redundant system, if an error occurs in the multiplexed remote master station of the control system, the multiplexed remote sub-master station of the standby system takes over the control of remote I/O stations. At the time of system switching, remote I/O stations hold the outputs (data).

The output holding time of remote I/O stations during system switching differs with the reason of system switching. In addition, it is affected by the CPU system switching time and the switching time between a multiplexed remote master station and a multiplexed remote sub-master station.

The following shows the calculation formula of output holding time for each reason for system switching.

(1) When a power failure or CPU module stop error occurs

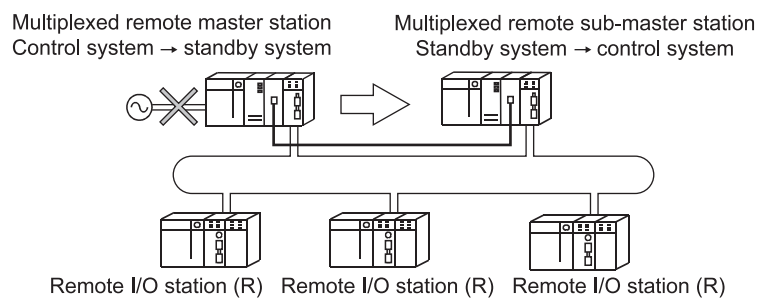

(a) CPU system switching time < System switching time from the multiplexed remote master station to the multiplexed remote sub-master station

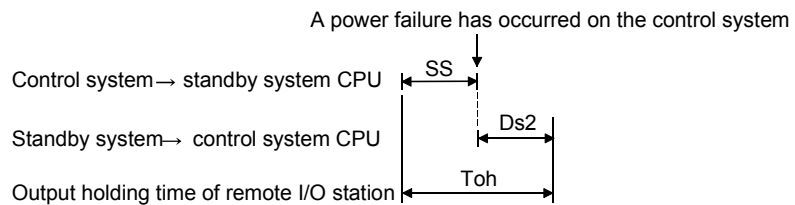

[Output holding time (Toh)]

$$Toh = Ds2 + SS \text{ [ms]}$$

Ds2: Switching time from the multiplexed remote master station to the multiplexed remote sub-master station [ms]

SS: Scanning time of the redundant CPU [ms]

- (b) CPU system switching time > Switching time from the multiplexed remote master station to the multiplexed remote sub-master station

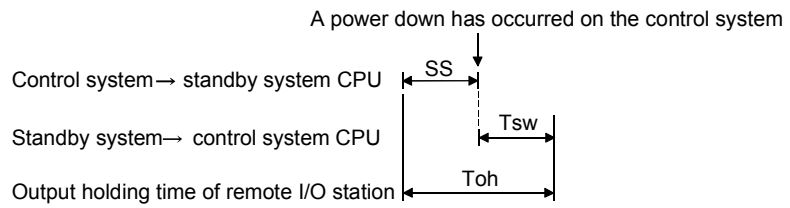

[Output holding time (Toh)]

$$Toh = Tsw + (SS \times 2) [ms]$$

Tsw: Redundant CPU system switching time [ms]
 SS: Scanning time of the redundant CPU [ms]

POINT	For the CPU system switching time, refer to QnPRHCPU User's Manual (Redundant System).
--------------	--

- (2) System switching when a system switching dedicated instruction is executed, a system switching request is issued by GX Developer, or the link cable is disconnected on other network module

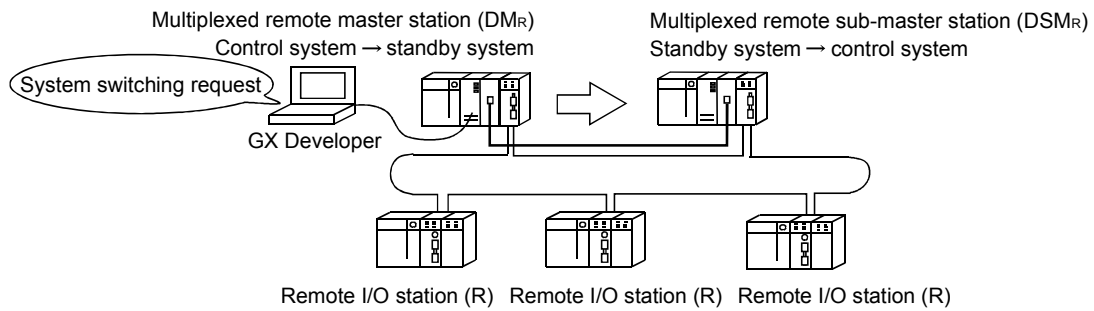

- (a) CPU system switching time < System switching time from the multiplexed remote master station to the multiplexed remote sub-master station

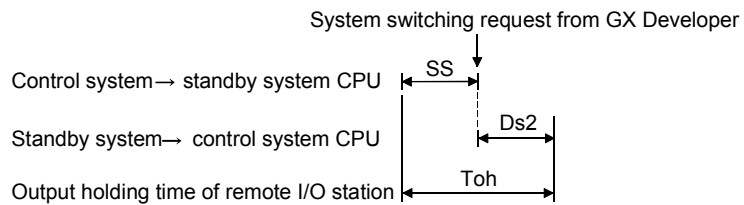

[Output holding time (Toh)]

$$Toh = Ds2 + SS \text{ [ms]}$$

Ds2: Switching time from the multiplexed remote master station to the multiplexed remote sub-master station [ms]

SS: Scanning time of the redundant CPU [ms]

- (b) CPU system switching time > Switching time from the multiplexed remote master station to the multiplexed remote sub-master station

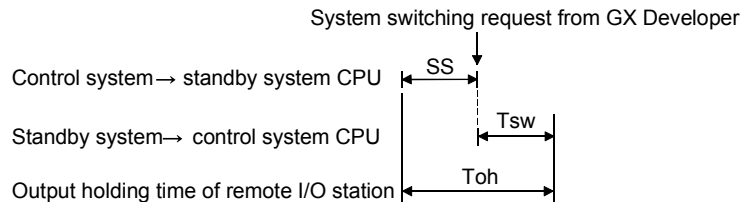

[Output holding time (Toh)]

$$Toh = Tsw + SS \text{ [ms]}$$

Tsw: Redundant CPU system switching time [ms]
 SS: Scanning time of the redundant CPU [ms]

POINT
 For the CPU system switching time, refer to QnPRHCPU User's Manual (Redundant System).

(3) System switching when the link cable disconnection occurs in the host network module

If a communication error occurs due to link cable disconnection on the host network module, it will considerably increase "data link monitoring time + switching monitoring time".

Therefore, the calculation formula is not affected by the CPU system switching time and the switching time from the multiplexed remote master station to the multiplexed remote sub-master station.

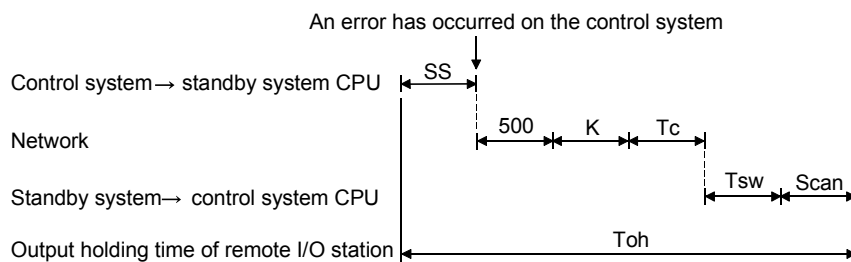
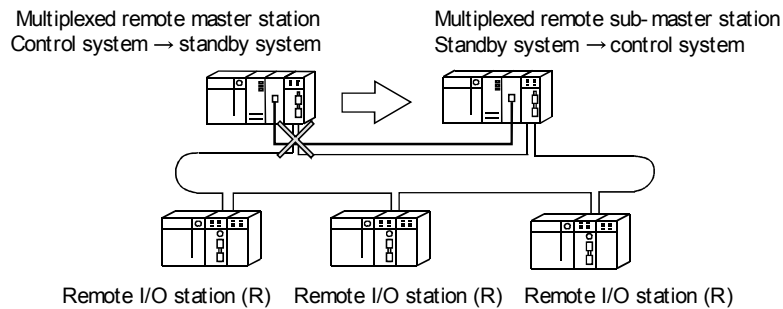

[Output holding time (Toh)]

$$Toh = 500 + K + Tc + Tsw + (SS \times 2) \text{ [ms]}$$

K: Data link monitoring time (set up by the common parameters in the network parameters) [ms]

Tc: Switching monitoring time (specify the setting range using SW0018) × 10ms [ms]

Tsw: Redundant CPU system switching time [ms]

SS: Scanning time of the redundant CPU [ms]

POINT

For the CPU system switching time, refer to QnPRHCPU User's Manual (Redundant System).

4 SETTING AND PROCEDURE BEFORE OPERATION

This chapter explains the procedures, settings, connections and testing that are required to start the data link operation.

4.1 Procedure Before Operation

The following is the procedure for performing the data link operation.

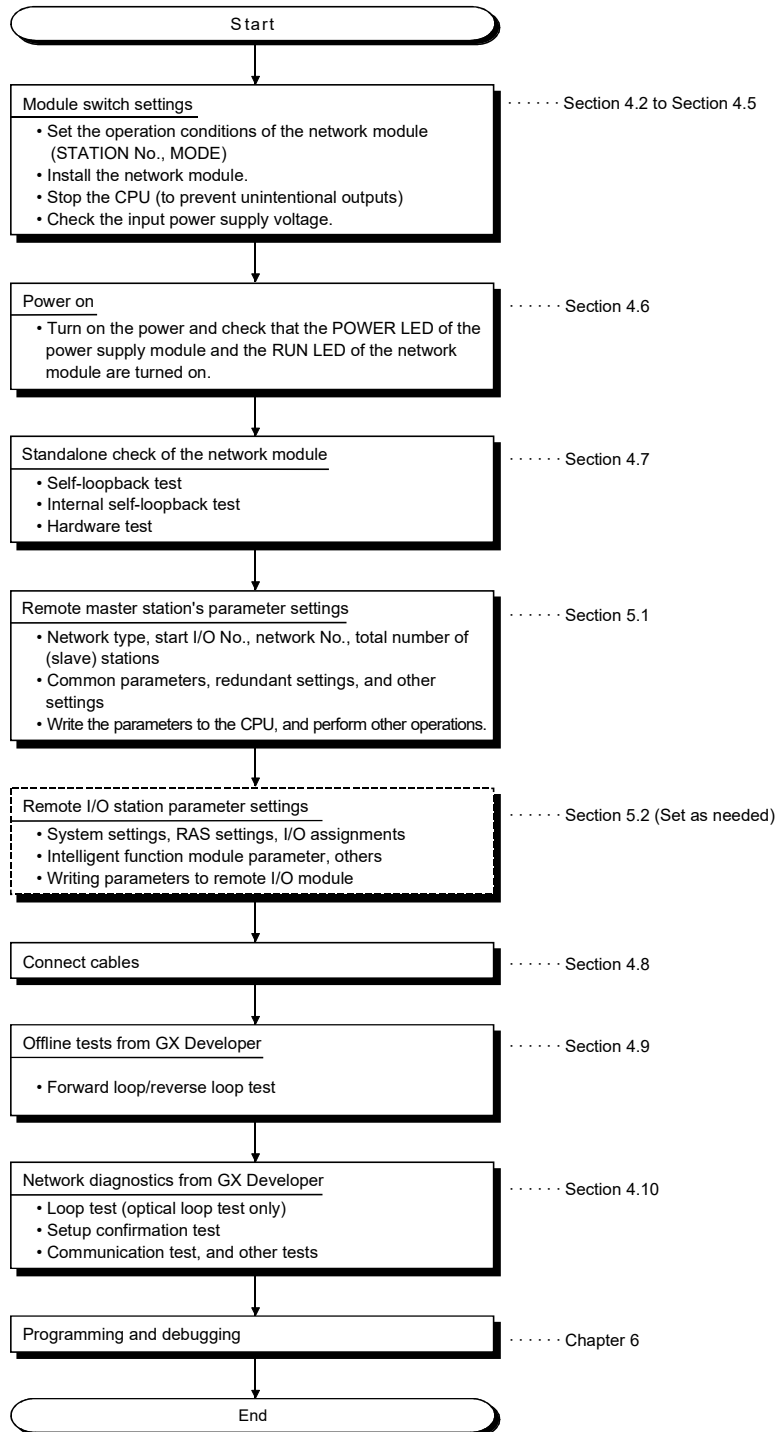

4.2 Part Names and Settings

4.2.1 QJ71LP21, QJ71LP21-25, QJ71LP21S-25, QJ71LP21G, QJ71LP21GE, QJ71BR11 (Remote master station)

- (1) QJ71LP21, QJ71LP21-25, QJ71LP21S-25, QJ71LP21G, QJ71LP21GE

QJ71LP21,
QJ71LP21-25

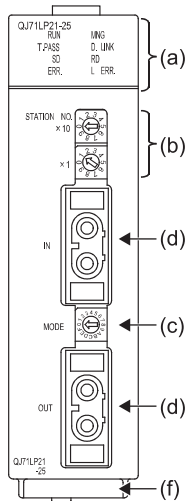

QJ71LP21S-25

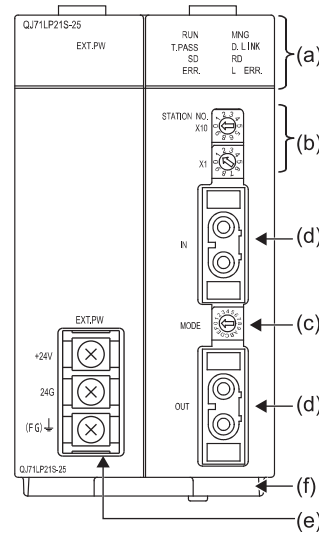

QJ71LP21G

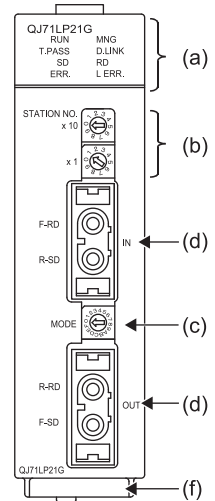

4

<Precautions>

The position of 0 of the rotary switches (b) and (c) and the display of the front of the module differ depending on the serial number of the module.

For applicable modules and the details, refer to Change of the Parts of Rotary Switch for the MELSEC-Q Series MELSECNET/H Network Modules (FA-A-0343).

(a) LED indications

No.	Name	LED status	Description
1	RUN	ON (green)	Normal operation
		OFF	Watchdog timer error (hardware failure)
2	MNG * 1	ON (green)	Operating as a remote master station
		OFF	Not operating as a remote master station
3	T.PASS	ON (green)	In the baton pass status (The module is connected to the network.)
		Flashing (green)	Being tested (When the LED flashes 20 times or more (approx. 10 seconds), it means the end of the test.)
		OFF	Not in the baton pass status (The host station has been disconnected from the network.)
4	D.LINK	ON (green)	Data link being performed (Cyclic transmission is being performed.)
		OFF	Data link not being performed (Parameters have not been received, an error has occurred in the CPU module of host station, a data link stop instruction has been issued, or others.)
5	SD	ON (green)	Data being sent
		OFF	Data not being sent
6	RD	ON (green)	Data being received
		OFF	Data not being received

* 1: The LED of the sub-master operating station in a multiplexed remote I/O network is off.

No.	Name	LED status	Description
7	ERR.	ON (red)	<ul style="list-style-type: none"> Station number setting error (other than 0 to 64.), mode setting error (set to disabled), operating condition setting error (in parameter), or mounted CPU type error (setting outside the range used, incorrect CPU type) A station with the same number already exists in the network. Invalid parameter setting Moderate or serious error of the CPU module
		Flashing	<ul style="list-style-type: none"> An error was detected while the network module was being tested. The setting of the mode setting switch or the station number setting switch was changed during operation. * 2
		OFF	Normal operation
8	L ERR.	ON (red)	Communication error (One of the following errors has been occurred.) CRC : This error occurs due to a fault in the cable or noise. OVER : This error occurs when the received data is erased before it is written to the internal memory because the next data is received. The possible error cause is a hardware failure at the receiver part of the network module. AB.IF : This error occurs when the number of the bits indicating "1" in the received data within a frame exceeds the limit or the received data length is shorter than that defined in the specifications. TIME : This error occurs when the baton pass is not handed to the host station within the monitoring time. DATA : This error occurs when the data with abnormal code is received. UNDER : This error occurs when the internal processing of the send data was not executed at a fixed interval. LOOP : This error occurs when the forward loop or reverse loop line is faulty. The power of the adjacent station in the direction to the host station is off or the hardware failure exists on the send station. <Corrective action> Check the connector for disconnection, looseness, and IN/OUT misconnection; and the cable for disconnection, crack, and routing. For details, refer to the network diagnostics (Section 8.1).
		OFF	No communication error
9	EXT. PW	ON (green)	External power being supplied (Power supply status of host (SB0042) is on.)
		OFF	External power not supplied (Power supply status of host (SB0042) is off.)

* 2: The ERR. LED of the following modules flashes if the module whose serial number (first five digits) is "02112" or later is used.

- QJ71LP21
- QJ71LP21-25
- QJ71BR11

(b) Station number setting switches

These switches set the station number of the network module in the network. (Factory default: 1)

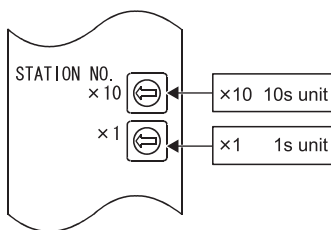

Setting	Description
0	Remote master station setting
1 to 64	Setting of a remote sub-master station
65 to 99	Setting error (The ERR. LED turns on (red).)

(c) Mode setting switch

This switch sets the operation mode. (Factory default: 0)

Set the mode setting switches in the same position on all network modules.

1) QJ71LP21, QJ71LP21G, QJ71LP21GE

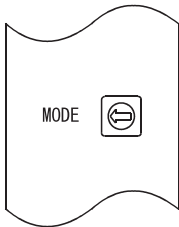

Setting	Description
0	Online (The mode selected by the parameter will be enabled.)
1	Self-loopback test
2	Internal self-loopback test
3	Hardware test
4 to F	Use prohibited

2) QJ71LP21-25, QJ71LP21S-25

Setting	Description	
0	Online (The mode selected by the parameter will be enabled.)	Communication speed: 10Mbps
1	Self-loopback test	
2	Internal self-loopback test	
3	Hardware test	
4	Online (The mode selected by the parameter will be enabled.)	Communication speed: 25Mbps
5	Self-loopback test	
6	Internal self-loopback test	
7	Hardware test	
8 to F	Use prohibited	

(d) IN/OUT connectors

An optical fiber cable connector is connected. (Refer to Section 4.8.1.)

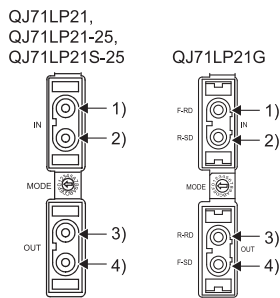

	Name
1)	IN: Forward loop receiving
2)	IN: Reverse loop sending
3)	OUT: Reverse loop receiving
4)	OUT: Forward loop sending

(e) External power supply terminal block

An external power supply is wired.

(f) Serial number display

This display indicates the serial number of the rating plate.

(2) QJ71BR11

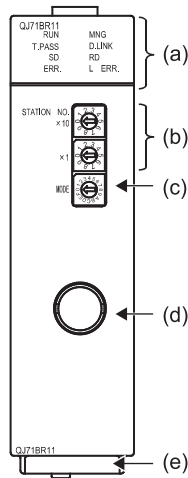

(a) LED indications
Same as the optical loop system. (Refer to Section 4.2.1 (1).)

(b) Station number setting switches
These switches set the station number of the network module in the network. (Factory default: 1)

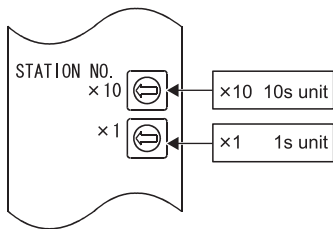

Setting	Description
0	Remote master station setting
1 to 32	Setting of a remote sub-master station
33 to 64	Setting error (The ERR. LED does not turn on (red).)
65 to 99	Setting error (The ERR. LED turns on (red).)

(c) Mode setting switch
This switch sets the operation mode. (Factory default: 0)
Set the mode setting switches in the same position on all network modules.

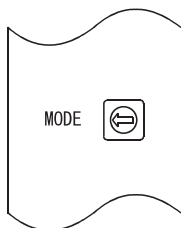

Setting	Description
0	Online (The mode selected by the network parameter will be enabled.)
1	Self-loopback test
2	Internal self-loopback test
3	Hardware test
4 to F	Use prohibited

(d) Coaxial connector
An F-type connector for a coaxial cable is connected. (Refer to Section 4.8.2.)

(e) Serial number display
This display indicates the serial number of the rating plate.

4.2.2 QJ72LP25-25, QJ72LP25G, QJ72LP25GE, QJ72BR15

(1) QJ72LP25-25, QJ72LP25G, QJ72LP25GE

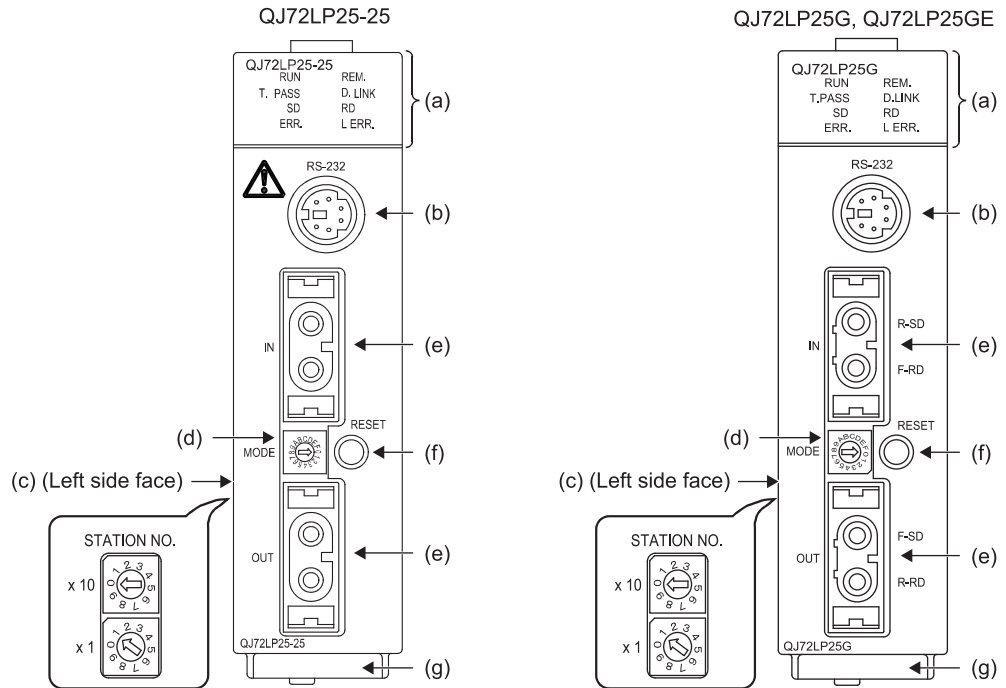

(a) LED indications

No.	Name	LED status	Description
1	RUN	ON (green)	Normal operation
		OFF	Watchdog timer error (hardware failure)
2	REM. *1	ON (green)	Normal operation
		Flashing (green)	Parameters being written to the flash ROM or in device test mode
		OFF	Being initialized remotely or error (watchdog timer error, fuse blown error, I/O module verify error, or other errors)
3	T.PASS	ON (green)	In the baton pass status (The module is connected to the network.)
		Flashing (green)	Being tested (When the LED flashes 20 times or more (approx. 10 seconds), it means the end of the test.)
		OFF	Not in the baton pass status (The host station has been disconnected from the network.)
4	D.LINK	ON (green)	Data link being performed (Cyclic transmission is being performed.)
		OFF	Data link not being performed (Parameters have not been received, an error has occurred in the CPU module of host station, a data link stop instruction has been issued, or others.)
5	SD	ON (green)	Data being sent
		OFF	Data not being sent
6	RD	ON (green)	Data being received
		OFF	Data not being received

No.	Name	LED status	Description
7	ERR. *1	ON (red)	<ul style="list-style-type: none"> Station number setting error (other than 1 to 64), mode setting error (set to disabled), or operating condition setting error (in parameter) A station with the same station number exists in the network. Parameter data received from the remote master station has an error. Watchdog timer error (The RUN LED is off.)
		Flashing	<ul style="list-style-type: none"> An error was detected while the network module was being tested. The setting of the mode setting switch or the station number setting switch was changed during operation. *2
		OFF	Normal operation
8	L ERR.	ON (red)	<ul style="list-style-type: none"> Watchdog timer error (The RUN LED is off.) Communication error (One of the following errors has been occurred.) <ul style="list-style-type: none"> CRC : This error occurs due to a fault in the cable or noise. OVER : This error occurs when the received data is erased before it is written to the internal memory because the next data is received. The possible error cause is a hardware failure at the receiver part of the network module. AB.IF : This error occurs when the number of the bits indicating "1" in the received data within a frame exceeds the limit or the received data length is shorter than that defined in the specifications. TIME : This error occurs when the baton pass is not handed to the host station within the monitoring time. DATA : This error occurs when the data with abnormal code is received. UNDER : This error occurs when the internal processing of the send data was not executed at a fixed interval. LOOP : This error occurs when the forward loop or reverse loop line is faulty. The power of the adjacent station in the direction to the host station is off or the hardware failure exists on the send station. <p><Corrective action> Check the connector for disconnection, looseness, and IN/OUT misconnection; and the cable for disconnection, crack, and routing. For details, refer to the network diagnostics (Section 8.1).</p>
		OFF	No communication error

*1: When the remote I/O module is used in a redundant power supply system, the cause of failure in the power supply module can be diagnosed with the status of the REM. LED and ERR. LED.

Power supply module	Cause of failure	REM. LED	ERR. LED
Failure of one module	Input power supply off, fuse blown	OFF	ON
	Internal failure	OFF	ON
		ON	OFF
Failure of both modules	Input power supply off, fuse blown	OFF	OFF
	Internal failure	OFF	OFF
		OFF	ON
	ON	OFF	

The faulty power supply module can be identified in the corresponding error code. (Refer to Section 8.3.3.)

When a remote I/O module of function version C or earlier is used, the ERR. LED remains off even if one or two power supply modules fail.

Check the failure status of the power supply module with the LEDs of the module. When the power supply module is mounted on an extension base unit, the failure status can also be checked with the ERR. contact of the module. (For the specifications of the LEDs of the power supply module, refer to the QCPU User's Manual (Hardware Design, Maintenance and Inspection).)

*2: The ERR. LED of the following modules flashes if the module whose serial number (first five digits) is "02112" or later is used.

- QJ72LP25-25
- QJ72BR15

- (b) RS-232 connector
A RS-232 cable for a peripheral is connected.

- (c) Station number setting switches
These switches set the station number of the network module in the network. (Factory default: 1)

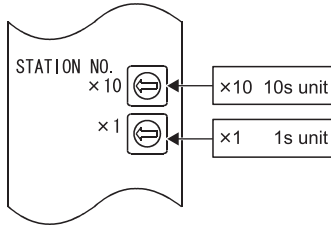

Setting	Description
0	Setting error (The ERR. LED turns on (red).)
1 to 64	Available setting range (When the QJ72BR15 is used, setting any of 33 to 64 will result in a setting error. However, the ERR. LED does not turn on (red).)
65 to 99	Setting error (The ERR. LED turns on (red).)

POINT
(1) Station numbers within a network must be unique. (2) Station numbers do not need to be in order. When not setting a station number, set the station as a reserved station.

- (d) Mode setting switch
This switch sets the operation mode. (Factory default: 0)
Set the mode setting switches in the same position (except the online (MELSECNET/10 mode)) on all network modules.

1) QJ72LP25-25

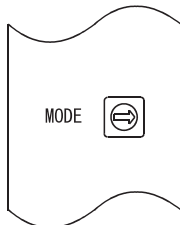

Setting	Description	
0	Online	Communication speed: 10Mbps
1	Self-loopback test	
2	Internal self-loopback test	
3	Hardware test	
4	Online (The mode selected by the parameter will be enabled.)	Communication speed: 25Mbps
5	Self-loopback test	
6	Internal self-loopback test	
7	Hardware test	
8	Online (MELSECNET/10 mode)	
9 to F	Use prohibited	

2) QJ72LP25G, QJ72LP25GE

Setting	Description
0	Online
1	Self-loopback test
2	Internal self-loopback test
3	Hardware test
4 to 7	Use prohibited
8	Online (MELSECNET/10 mode)
9 to F	Use prohibited

(e) IN/OUT connectors

An optical fiber cable connector is connected. (Refer to Section 4.8.1.)

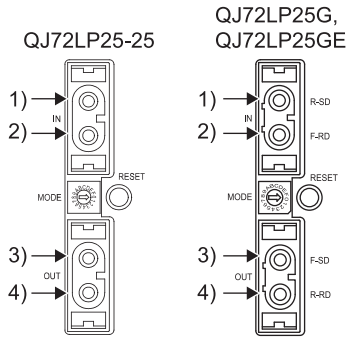

(f) RESET switch

This switch resets the modules on the remote I/O station. Press the switch for one second or longer to reset. If not, the modules on the station cannot be reset normally. If the modules have not been reset normally, perform the reset operation again.

(g) Serial number display

The serial number on the rating plate is displayed.

(2) QJ72BR15

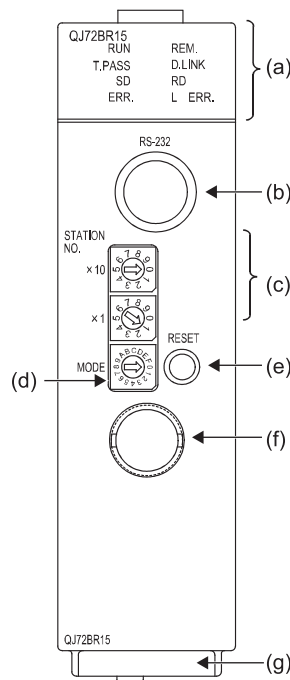

- (a) Indicator LEDs
Same as the optical loop system. (Refer to Section 4.2.2 (1).)
- (b) RS-232 connector
Same as the optical loop system. (Refer to Section 4.2.2 (1).)
- (c) Station number setting switch
Same as the optical loop system. (Refer to Section 4.2.2 (1).)
- (d) Mode setting switch
This switch sets the operation mode. (Factory default: 0)
Set the mode setting switches in the same position (except the online (MELSECNET/10 mode)) on all network modules.

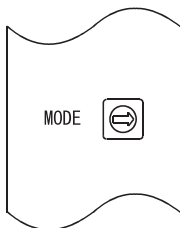

Setting	Description
0	Online
1	Self-loopback test
2	Internal self-loopback test
3	Hardware test
4 to 7	Use prohibited
8	Online (MELSECNET/10 mode)
9 to F	Use prohibited

- (e) RESET switch
Same as the optical loop system. (Refer to Section 4.2.2 (1).)
- (f) Coaxial connector
An F-type connector for a coaxial cable is connected. (Refer to Section 4.8.2.)
- (g) Serial number display
The serial number on the rating plate is displayed.

4.3 Installing and Uninstalling the Module

(1) Installing the module

Fully insert the module fixing latch into the module fixing hole in the base unit (exercise care not to allow the module fixing latch to separate from the module fixing hole).

Using the module fixing hole as a fulcrum, push the module in the direction of arrow to mount it into the base unit.

Check that the module is securely fixed to the base unit

Complete

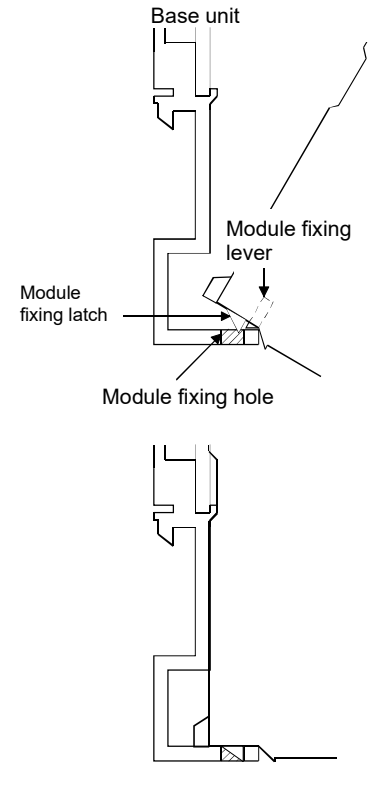
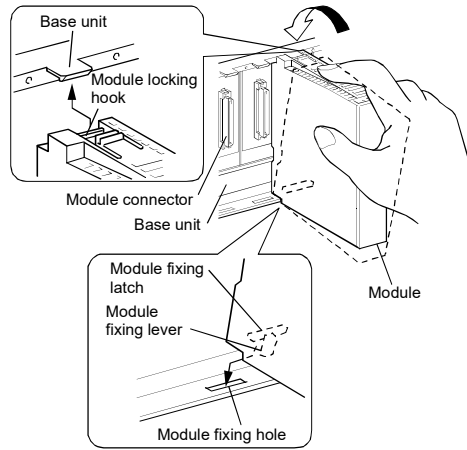

(2) Uninstalling the module

Hold the module by both hands, and push the module locking hook on the top of the module until it stops.

Pushing the module locking hook, pull the module downward.

Lift the module to disengage the module fixing latch from the module fixing hole.

Complete

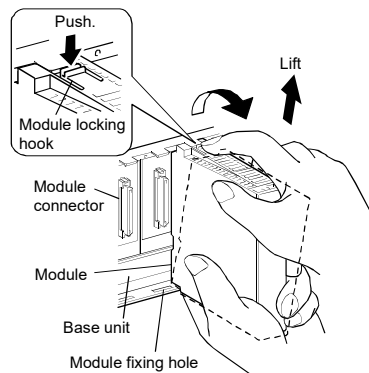

[Module handling precautions]

- Since the module case is made of resin, do not drop it or subject it to strong impacts.
- The module can be easily fixed onto the base unit using the hook at the top of the module. However, it is recommended to secure the module with the module fixing screw if the module is subject to significant vibration or shock. In this case, tighten the module fixing screws within the following clamping torque range.
Module fixing screws (M3): clamping torque ranging from 0.36 to 0.48 N•m
- Tighten the external power supply terminal screw of QJ71LP21S-25 within the following torque range:
For the specification of the external power supply terminal, refer to section 3.1.1.
External power supply terminal screw (M3): torque ranging from 0.42 to 0.58 N•m
- Use drivers, which match the following recommended driver dimensions, for the operation of the station number setting switch and the mode setting switch. Using drivers with unsuitable edge width or thickness may damage the switches.

Recommended driver dimensions	
Edge width (L)	2.0 to 2.4mm
Edge thickness (W)	0.5 to 0.6mm

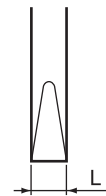

Front view of blade edge



Side view of blade edge

	<p>WARNING</p> <ul style="list-style-type: none"> • Do not touch any terminal or connector while power is on. Doing so will cause electric shock or malfunction. • Incorrect mounting or screwing may cause malfunction, failure, or drop of the module. Overtightening can damage the screw and/or module, resulting in drop, short circuit, or malfunction.
--	--

	<p>CAUTION</p> <ul style="list-style-type: none"> • Prevent foreign matter such as dust or wire chips from entering the module. Such foreign matter can cause a fire, failure, or malfunction. • Do not disassemble or modify the module. Doing so may cause failure, malfunction, injury, or a fire.
--	--

4.4 Stopping the CPU (Unintentional Output Prevention)

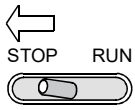

Set the CPU module's RUN/STOP switch to the STOP side.

4.5 Checking the Input Power Supply Voltage

Check that the supply power voltage to the power supply module is within the specifications.

4.6 Powering On

Check the power supply to the network module.

4.6.1 Checking the on status of the POWER LED of the power supply module

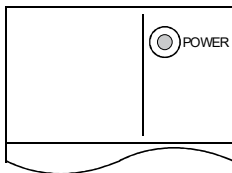

The POWER LED lights up at the same time when the programmable controller system is powered on.

4.6.2 Checking the on status of the RUN LED of the network module

Remote master station

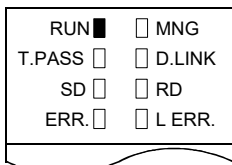

The RUN LED lights up in green when the network module of remote master station and remote I/O station is operating normally.

If this LED does not light up, refer to Chapter 8, "Troubleshooting."

Remote I/O station

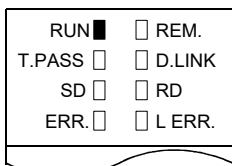

4.7 Unit Tests of the Network Module (Offline Test)

The network module and the connected cable shall be tested before executing the data link operation. Select the test item with the mode setting switch on the front of the network module. The following three items are provided as the offline test.

- (1) Self-loopback test (mode setting switch: 1 or 5)
This test checks the internal circuits including the send/receive circuits of the network module together with the connected cable.
- (2) Internal self-loopback test (mode setting switch: 2 or 6)
This test checks the internal circuits including the send/receive circuits of the network module.
- (3) Hardware test (mode setting switch: 3 or 7)
This test checks the internal components of the network module.

Flow of offline tests

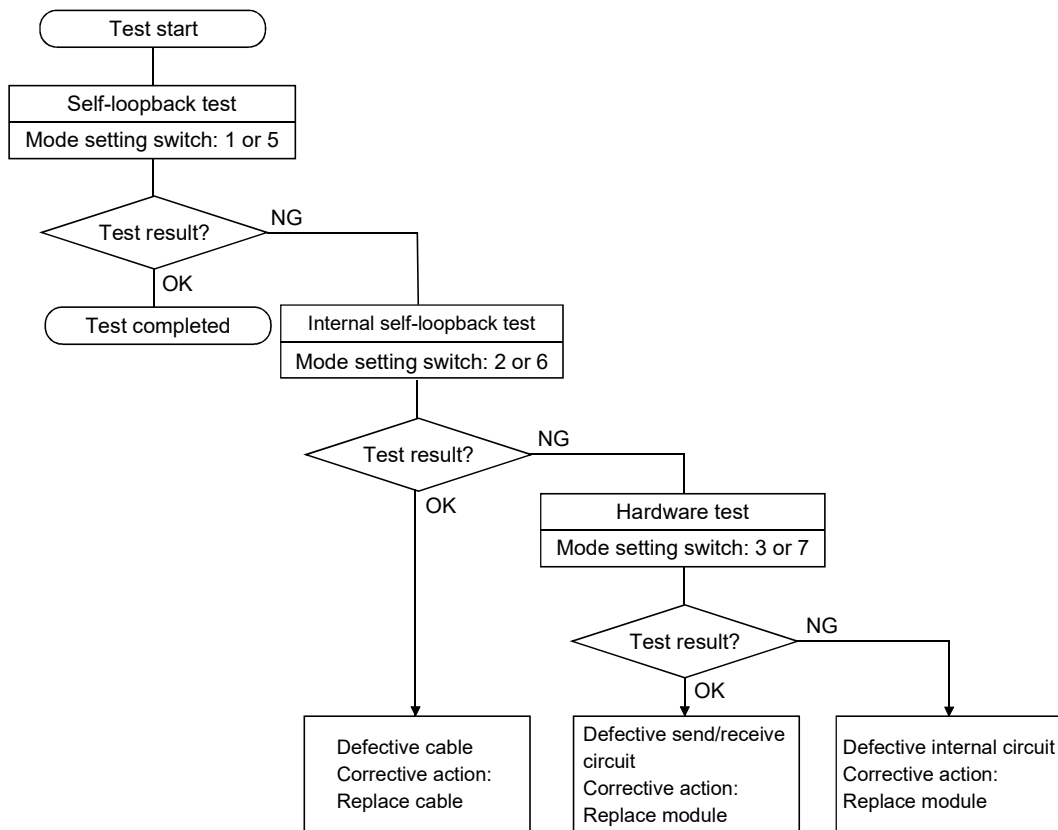

POINT
If the test completes with an error, the possible cause is a hardware failure of the network module. Please consult your local Mitsubishi representative.

REMARKS

If even one station is set to the test mode (offline, mode setting switch 1 to 3 or 5 to 7) during the data link (online), the normal data link cannot be maintained.

4.7.1 Self-loopback test

This test checks the internal circuits including the send/receive circuits of the network module together with the connected cable.

POINT

Always connect a cable or terminating resistors when performing the self-loopback test.

In addition, do not connect or disconnect the cable or terminating resistors during the test. (The test completes with an error.)

- (1) For the QJ71LP21/QJ72LP25 network module (for the optical loop system), connect the IN connector and OUT connector with an optical fiber cable.
 For the QJ71BR11/QJ72BR15 network module (for the coaxial bus system), connect terminating resistors to both connectors of the F-type connectors.
- | | |
|--|---|
| For QJ71LP21/QJ72LP25
(optical loop system) | For QJ71BR11/QJ72BR15
(coaxial bus system) |
|--|---|

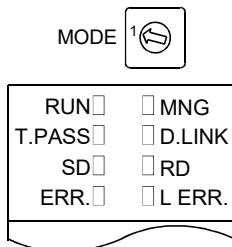
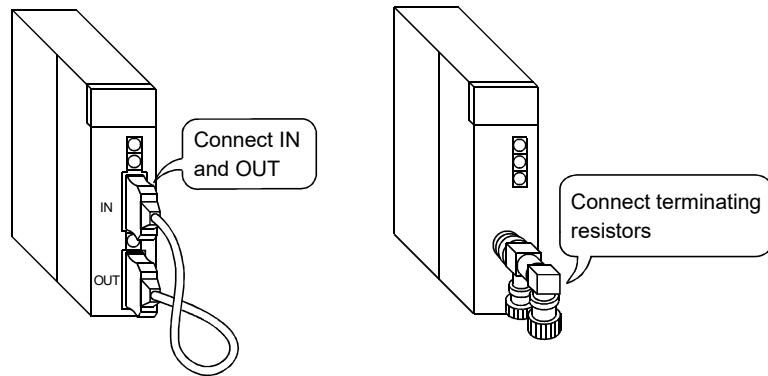

- (2) Set the mode setting switch of the network module to "1". Set it to "5" when using the QJ71LP21/QJ72LP25 at 25Mbps.
- (3) Power on the target station.
 The self-loopback test starts and the T.PASS LED flashes.
- (4) The test is completed normally when the T.PASS LED flashes 20 or more times (approx. 10 seconds) and the ERR. LED does not flash. When the test completes with an error, the ERR. LED flashes.

If an error occurs, perform the following.

- For the QJ71LP21/QJ72LP25 (for the optical loop system), replace the cable and perform the test again.
- For the QJ71BR11/QJ72BR15 (for the coaxial bus system), replace the terminating resistors and perform the test again.

When the test completes with an error again, the possible cause is a hardware failure of the network module. Please consult your local Mitsubishi representative.

REMARKS

Check the test condition and error details with the following link special register areas.

- Baton pass status (host) (SW0047) → 1FH: Offline test
- Cause of baton pass interruption (SW0048) → 2H: Offline test
- Offline test execution item/faulty station (requesting side) (SW00AC) → 7H: Self-loopback test
- Offline test result (requesting side) (SW00AD) → 0: Normal, 1 and later: Error code

4.7.2 Internal self-loopback test

This test checks the internal circuits including the send/receive circuits of the network module.

- (1) Do not connect an optical fiber cable for the QJ71LP21/QJ72LP25 network module (for the optical loop system). Prevent ambient light from entering the connector.

Do not connect a cable or terminating resistor to the QJ71BR11/QJ72BR15 network module (for the coaxial bus system).

For QJ71LP21/QJ72LP25
(optical loop system)

For QJ71LP21/QJ72BR15
(coaxial bus system)

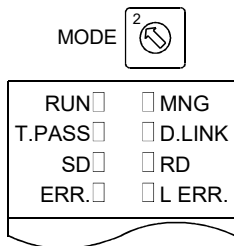
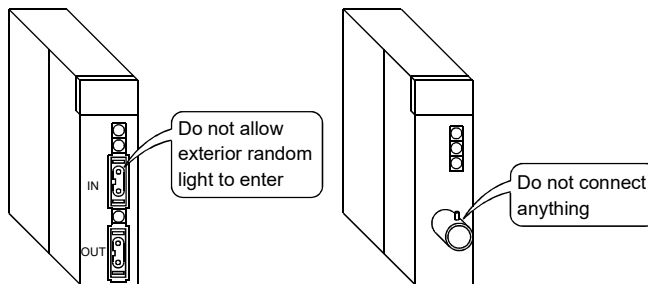

- (2) Set the mode setting switch of the network module to "2". Set it to "6" when using the QJ71LP21/QJ72LP25 at 25Mbps.
- (3) Power on the target station.
The internal self-loopback test starts and the T.PASS LED flashes.
- (4) The test is completed normally when the T.PASS LED flashes 20 or more times (approx. 10 seconds) and the ERR. LED does not flash. When the test completes with an error, the ERR. LED flashes.

When the test completes with an error, the possible cause is a hardware failure of the network module. Please consult your local Mitsubishi representative.

REMARKS

Check the test condition and error details with the following link special register areas.

- Baton pass status (host) (SW0047) → 1FH: Offline test
- Cause of baton pass interruption (SW0048) → 2H: Offline test
- Offline test execution item/faulty station (requesting side) (SW00AC) → 8H: Internal self-loopback test
- Offline test result (requesting side) (SW00AD) → 0: Normal, 1 and later: Error code

4.7.3 Hardware test

This test checks the internal components of the network module.

- (1) For the QJ71LP21/QJ72LP25 network module (for the optical loop system), connect the IN connector and OUT connector with an optical fiber cable. Do not connect cables or terminating resistors if the QJ71BR11/ QJ72BR15 network module (for the coaxial bus system) is used.

For QJ71LP21/QJ72LP25
(optical loop system)

For QJ71LP21/QJ72BR15
(coaxial bus system)

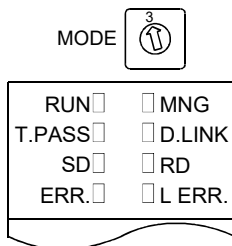
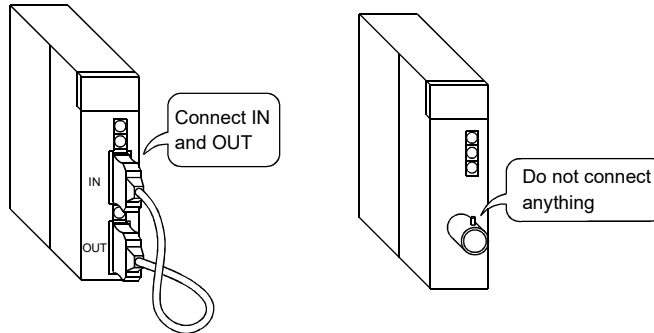

- (2) Set the mode setting switch of the network module to "3". Set it to "7" when using the QJ71LP21/QJ72LP25 at 25Mbps.
- (3) Power on the target station. The hardware test starts and the T.PASS LED flashes.
- (4) The test is completed normally when the T.PASS LED flashes 20 or more times (approx. 10 seconds) and the ERR. LED does not flash. When the test completes with an error, the ERR. LED flashes.

When the test completes with an error, the possible cause is a hardware failure of the network module. Please consult your local Mitsubishi representative.

REMARKS

Check the test condition and error details with the following link special register areas.

- Baton pass status (host) (SW0047) → 1FH: Offline test
- Cause of baton pass interruption (SW0048) → 2H: Offline test
- Offline test execution item/faulty station (requesting side) (SW00AC) → 9H:
Hardware test
- Offline test result (requesting side) (SW00AD) → 0: Normal, 1 and later: Error code

4.8 Cable Connections

4.8.1 Optical loop system

(1) Precautions when connecting

- (a) The type of cables that can be used will vary according to the distance between stations.

Type		Interstation distance			
		QJ71LP21, QJ71LP21-25, QJ71LP21S-25, QJ72LP25-25 : 10 Mbps	QJ71LP21-25, QJ71LP21S-25, QJ72LP25-25 : 25 Mbps	QJ71LP21G QJ72LP25G	QJ71LP21GE QJ72LP25GE
SI optical fiber cable (Old type: A-2P- □)	L type	500m	200m	Must not be used	Must not be used
	H type	300m	100m		
SI optical fiber cable		500m	200m		
H-PCF optical fiber cable		1000m	400m		
Broad-band H-PCF optical fiber cable		1000m	1000m		
QSI optical fiber cable		1000m	1000m		
GI-50/125 optical fiber cable		Must not be used	Must not be used	2000m	Must not be used
GI-62.5/125 optical fiber cable		Must not be used	Must not be used	Must not be used	2000m

- (b) When an optical fiber cable is connected, the following restrictions on the bending radius should be observed.
For details, check the specifications of the cable to be used.
- (c) Maintain the bending radius of the optical fiber cable within the allowable range using a tool for securing the optical fiber cable bending radius.
This tool may be purchased from Mitsubishi Electric System Service, Inc, or your nearest dealer. Please inquire for more information.
- (d) When laying the optical fiber cables, do not touch the fiber cores of the cable and module connectors, and do not let dust or particles collect on them.
If oil from hands, dust or particles adhere to the cores, the accumulated transmission loss may cause malfunctions in the data link.
Also, do not remove the cover from the module-side connector until the optical fiber cable is ready to be installed.
- (e) When connecting or disconnecting an optical fiber cable, hold the connector part of the cable.
- (f) Connect the cable and module connectors securely until you hear a "click" sound.
- (g) Be sure to shut off all phases of the external power supply used in the system before connecting or disconnecting optical fiber cables.

(2) Cable connection

(a) How to connect the cable

Note that there is no need to connect the cables in the order of station numbers.

Set the station number of the remote master station to 0.

a - 1) QJ71LP21-25 - QJ72LP25-25, QJ71LP21G - QJ72LP25G

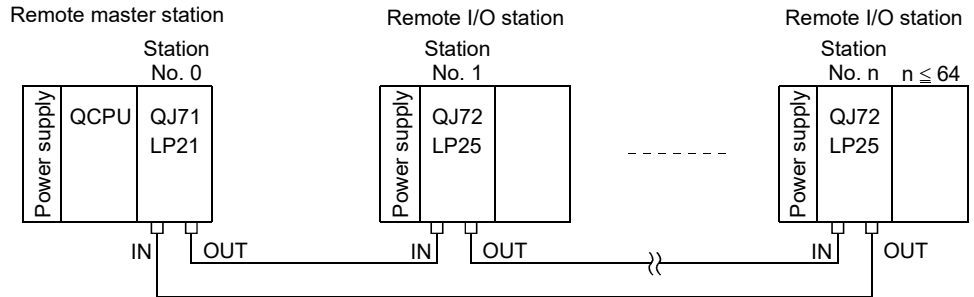

a - 2) QJ71LP21GE - QJ72LP25GE

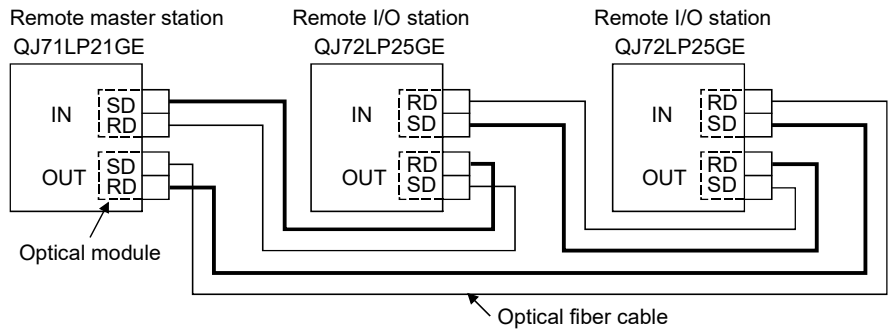

(b) Installing the optical fiber cable

The following are how to install the optical fiber cable:

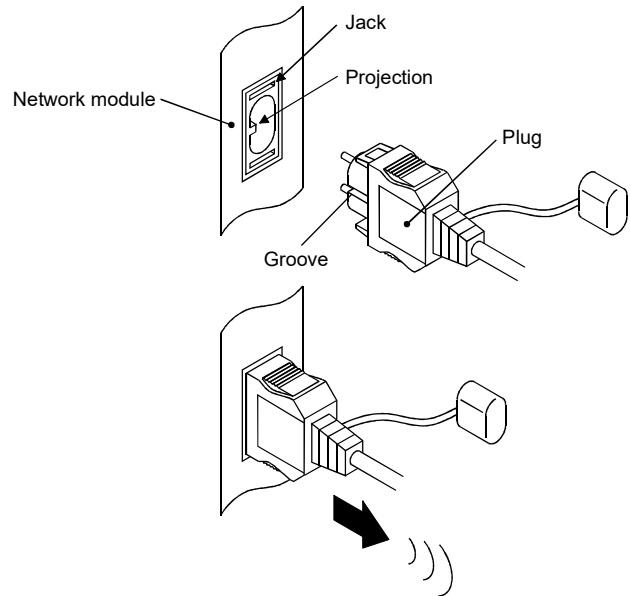
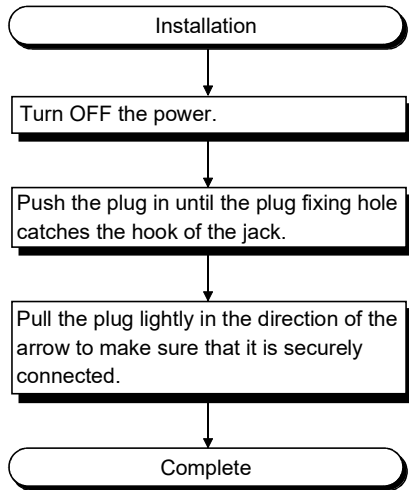

(c) Removing the optical fiber cable

The following are how to remove the optical fiber cable:

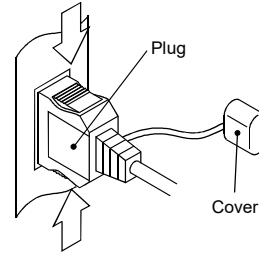
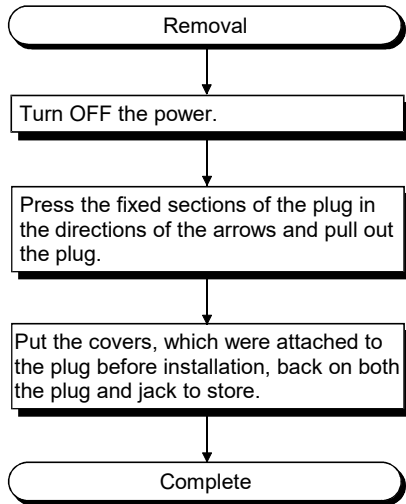

POINT

Data link operation may be executed even if IN and IN or OUT and OUT are connected with an optical fiber cable. However, the loopback function, the network diagnostic function and some of other functions do not operate normally. So, make sure to connect OUT and IN.

The wiring status can be checked by either of the following methods.

- (1) When checking by stopping data link
Conduct a loop test in the network diagnostics of GX Developer. (Refer to Section 4.10.1.)
- (2) When checking without stopping data link
Check the status of SW009C to 9F. (Refer to Section 8.2.10.)

4.8.2 Coaxial bus system

(1) Precautions in connecting

(a) Restrictions on the cable length between the stations

- 1) When connecting between the network modules, the cable lengths indicated in the table below should be used according to the number of stations connected.

A communication error may occur if a cable length other than the lengths indicated in the table is used.

Number of stations connected \ Station-to-station cable length	2 to 9 stations			10 to 33 stations		
	Cable type	3C-2V	5C-2V	5C-FB	3C-2V	5C-2V
0 to 1 m	× (cable less than 1m in length cannot be used.)					
1 to 5 m	○	○	○	○	○	○
5 to 13 m	○	○	○	×	×	×
13 to 17 m	○	○	○	○	○	○
17 to 25 m	○	○	○	×	×	×
25 to 300 m	○	○	○	○	○	○
300 to 500 m	×	○	○	×	○	○

○: Allowed ×: Not allowed

- 2) If there is a possibility of adding more stations to expand the existing system, the cables should be installed by considering restriction 1) mentioned above in advance.
- 3) When using a repeater module (models A6BR10 or A6BR10-DC), use the station-to-station cable length for "10 to 33" stations, regardless of the number of stations connected or the number of repeater modules.

(b) Cable installation precautions

- 1) Install the coaxial cables at least 100 mm away from other power cables and control cables.
- 2) Consider to use double shield coaxial cables in locations where there is excessive noise.
- 3) To configure a multiplexed remote I/O network for redundant system, use a double shield coaxial cable.

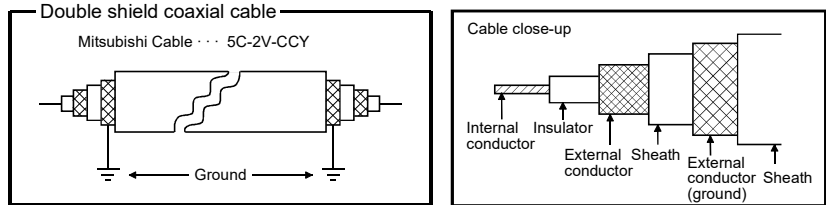

A 5C-2V connector plug can be applied to double-shielded coaxial cable.

Ground the shielded section, external part of the double shield coaxial cable, as shown above.

Connect the external conductor (grounding surface) of the double-shielded coaxial cable 10mm away from the 5C-2V connector plug. (Avoid connection between them.)

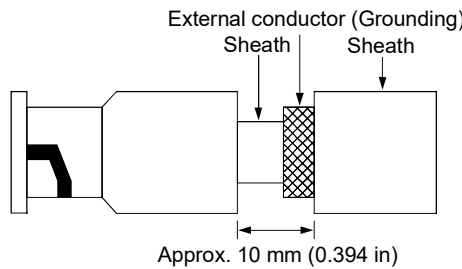

(c) When a coaxial cable is connected, the following restrictions on the bending radius must be observed.

Cable type	Allowable bending radius r	Connector A
3C - 2V	23mm	55mm
5C - 2V	30mm	
5C - FB	30mm	

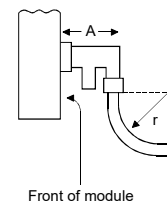

- (d) Do not pull any of the connected coaxial cables. This may cause a faulty contact and cable disconnection, or damage the module.
- (e) For coaxial bus type network systems, be sure to connect both end stations to the terminal register.
- (f) Depending on the usage environment, some white oxidation deposits may be seen on the F type connector. However, oxidation will not occur on the connection area, so there will be no problems with the function of the unit.
- (g) Be sure to shut off all phases of the external power supply used in the system before connecting or disconnecting coaxial cables.

(2) Cable connection

(a) Connection method

Connect the coaxial cable as shown below.

Always install a terminating resistor (sold separately: A6RCON-R75) to the stations connected at both ends.

The F-type connector (A6RCON-F) comes with the module.

1) Without a repeater module

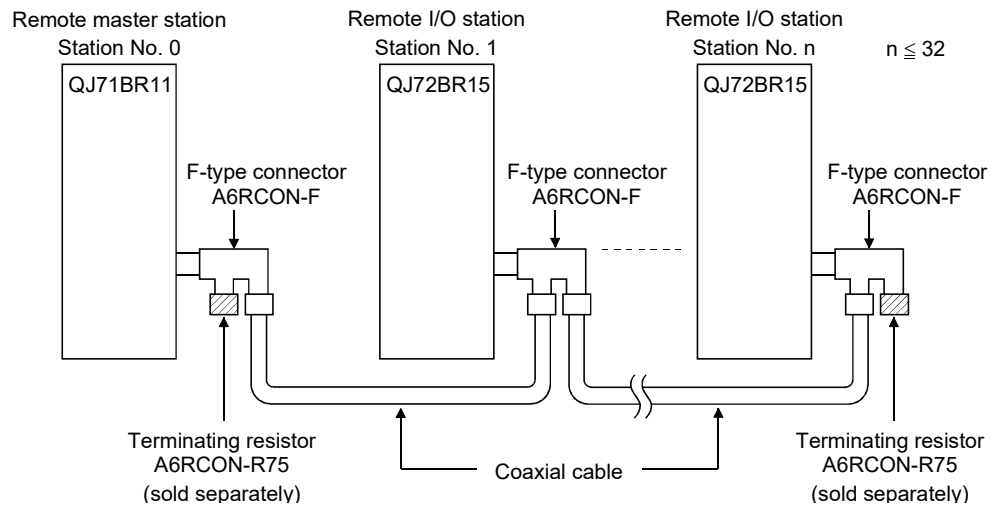

2) With a repeater module (series connection)

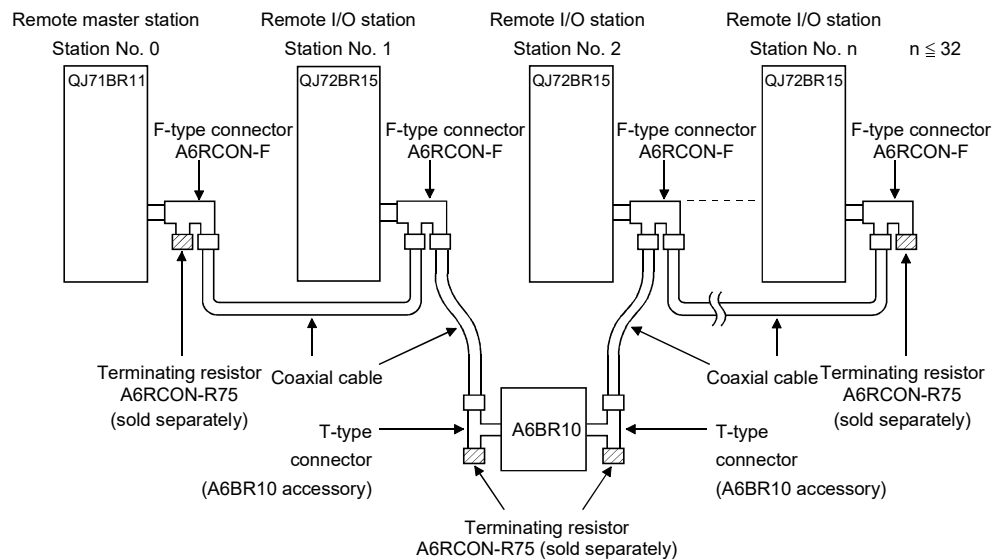

REMARKS

For details about the repeater module (A6BR10), refer to the following user's manual attached to the product:

Model A6BR10/A6BR10-DC MELSECNET/10 Coaxial Bus System
Repeater Module User's Manual (IB-66499)

3) With a repeater module (branch connection)

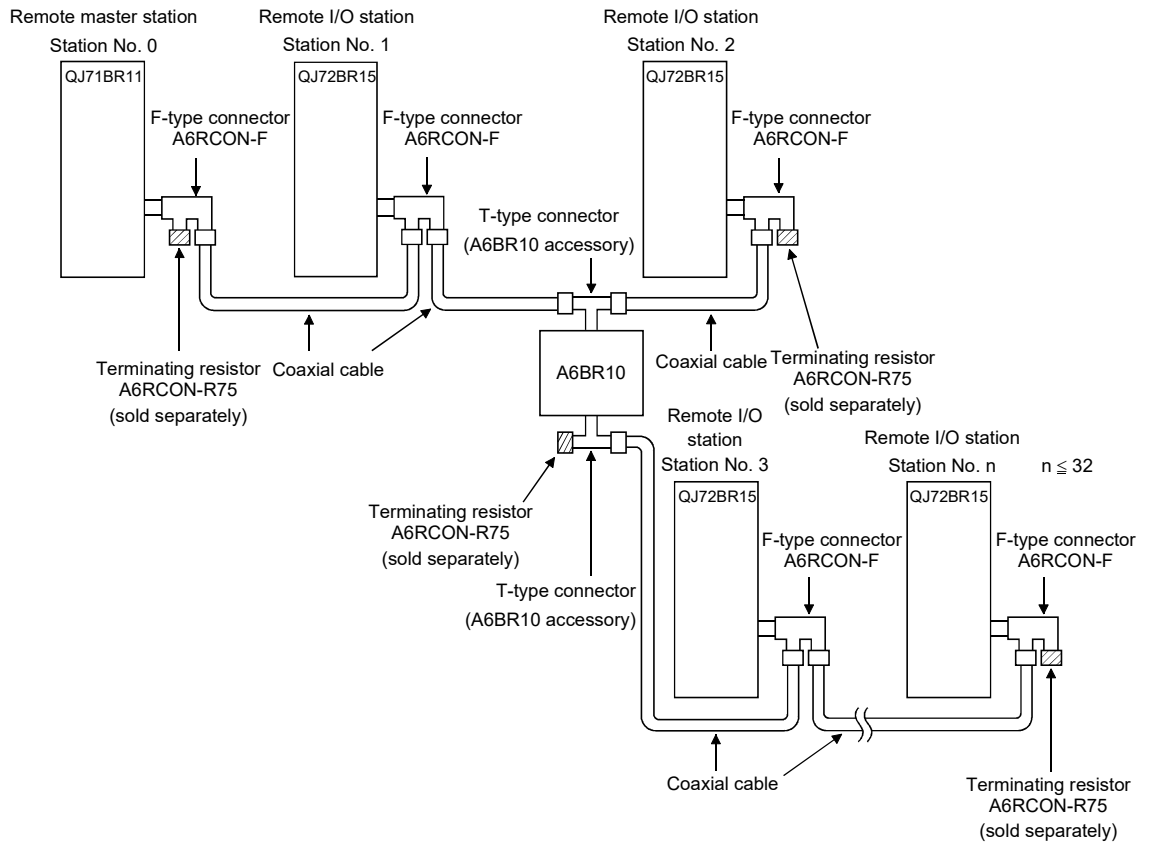

POINT

- (1) By setting stations that will be connected in future (stations that are included in the number of stations but not actually connected) as reserved stations, a communication error can be prevented and the link scan time will not be affected.
- (2) The two connectors of the F-type connector are not dedicated to IN and OUT. A coaxial cable can be connected to either of them.
- (3) A terminating resistor can be placed on either side of the F-type connector.

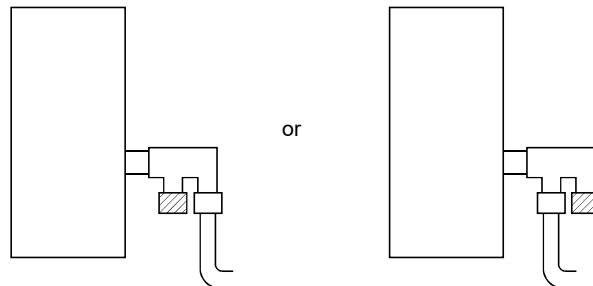

(b) Installing the coaxial cable

The following are how to install the coaxial cable:

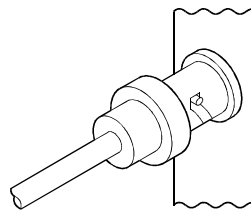
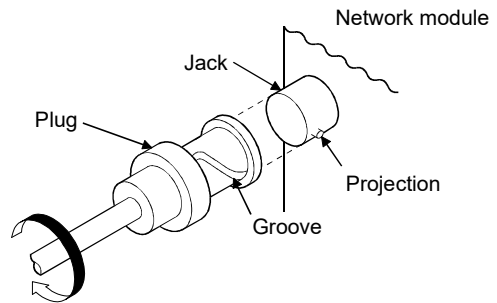
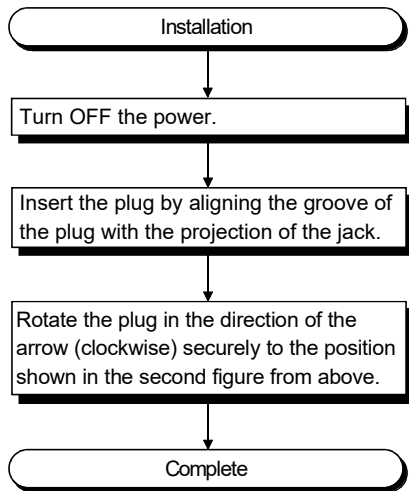

(c) Removing the coaxial cable

The following are how to remove the coaxial cable:

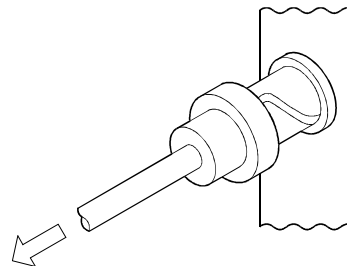
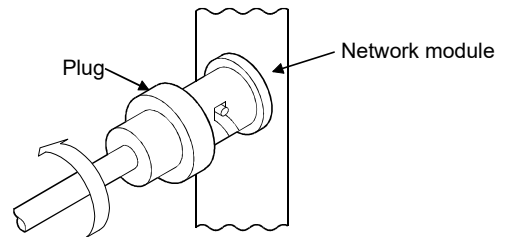
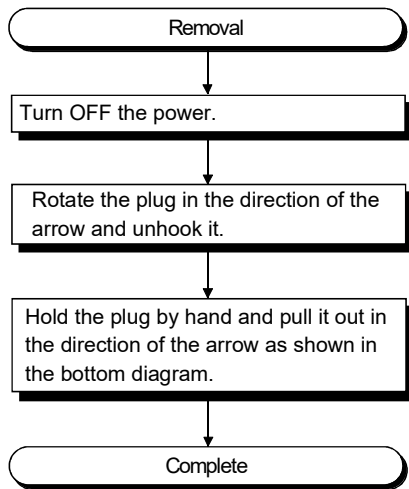

4.9 Offline Tests from GX Developer

The offline tests check the cable connection status using the network parameters of GX Developer.

4.9.1 Forward loop/reverse loop test (Remote master station only)

The forward loop/reverse loop test checks the hardware of the network modules and cables after all stations are connected with optical fiber cables. It also checks whether the cables are connected between IN and OUT connections properly.

The following explains how to conduct the forward loop/reverse loop test:

(1) Setting the test mode



- (a) Mode for performing the forward loop/reverse loop test on a system other than the redundant system

When conducting the forward loop test, set the mode network parameter of the station that will be executing the forward loop test to "Forward loop test" with GX Developer and write the parameter setting to the CPU module.

Set the mode for all other stations than the testing station to "Online."

When conducting the reverse loop test, set the mode network parameter of the station that will be executing the reverse loop test to "Reverse loop test" with GX Developer and write the parameter setting to the CPU module.

Remote master station

Module 1	
Network type	MNET/H(Remote master) 
Starting I/O No.	0000
Network No.	1
Total stations	5
Group No.	
Station No.	
Mode	Forward loop test 
Network range assignment	

Set

- (b) Setting the mode when performing the forward loop/reverse loop test on the redundant system

When conducting the forward loop/reverse loop test on the redundant system, set the operation mode of the redundant CPU to the backup mode in advance.

When it the power supplies of both the systems cannot be powered on/off, perform the forward loop/reverse loop test in the separate mode.

The table below lists the mode settings when conducting the forward loop/reverse loop test on the redundant system.

Target station			Set-up
Test target station	Redundant system	In the backup mode	Set the mode to "Forward loop test" or "Reverse loop test".
		In the separate mode	
Non-test target station	Redundant system	In the backup mode	Set the mode to "Offline".
		In the separate mode	Set the mode to "Online".
	Remote I/O station	Set the mode to "Online".	

The figure below shows the settings when the forward loop test is executed on the system A (station No. 1) of the redundant system (in the backup mode).

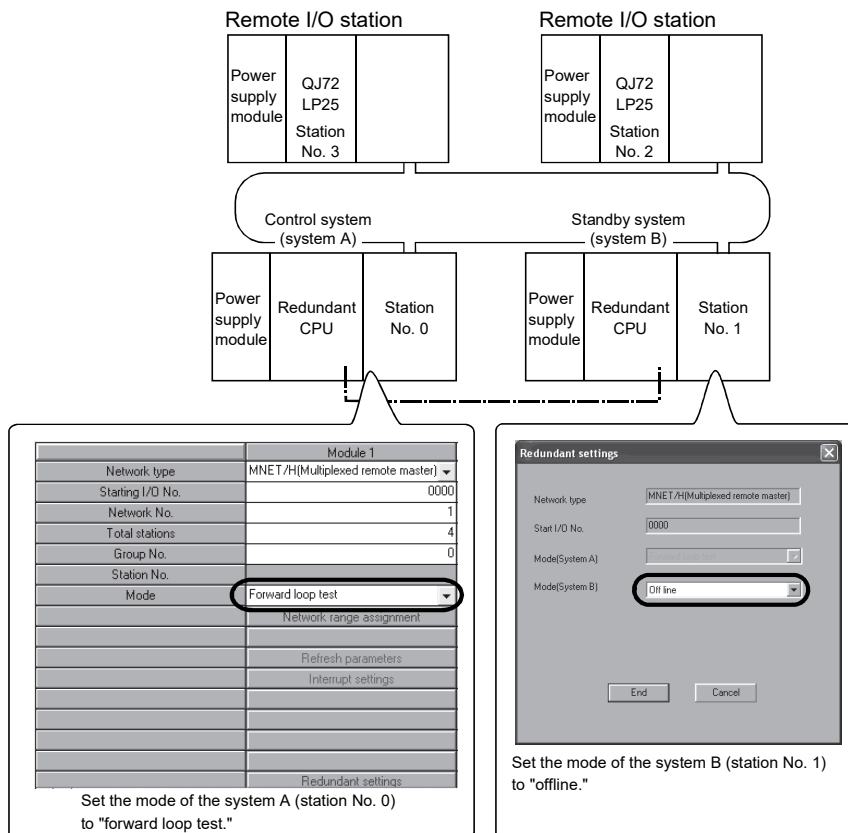

(2) Starting the test

(a) High Performance model QCPU, Process CPU, and Redundant CPU

Set the RUN/STOP switch of the CPU module to the STOP position. When resetting the CPU module, use the RESET/L.CLR switch.

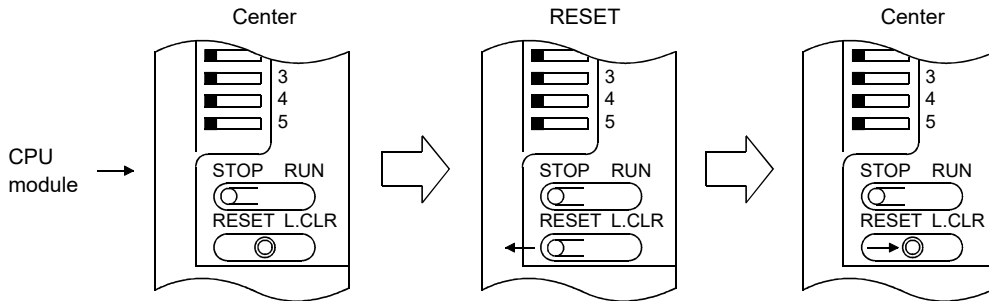

(b) Universal model QCPU

Reset with the RESET/STOP/RUN switch.

Hold the switch in the RESET position until the ERR. LED starts flashing, and release it after the LED turns off.

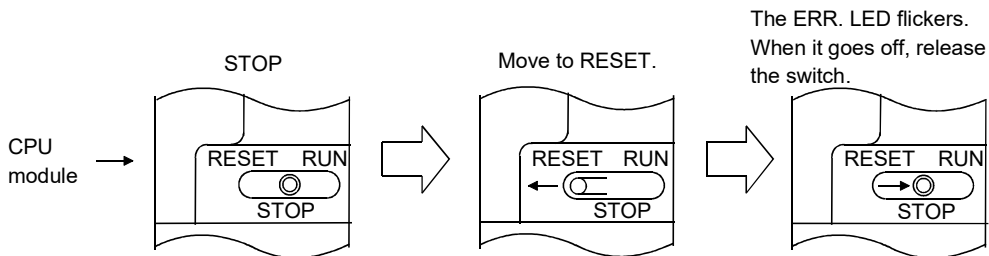

POINT

To execute the forward loop/reverse loop test, connect the cable correctly to OUT and IN.
 Also, do not connect or disconnect the cable during execution of the test. (Doing so will result in test failure.)

(3) Checking the test result

The T.PASS LED of the network module flashes at approximately 0.5 s intervals. When the T.PASS LED flashes 20 times (approx. 10s) or more and if the ERR.LED does not flash, this condition indicates normal completion. When the test has failed, the ERR. LED flashes. Check the test result with the LEDs of the testing station.

[Normal test result]

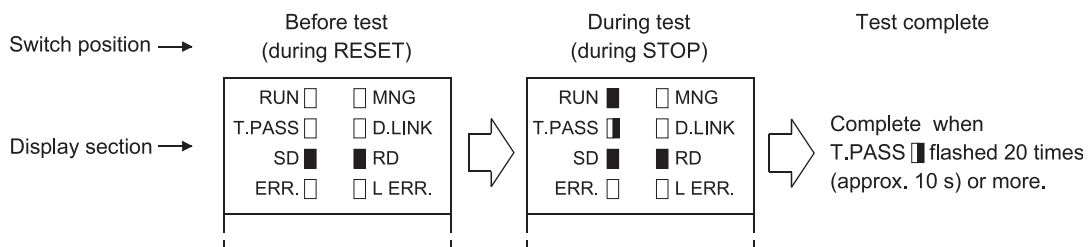

[Abnormal test result]

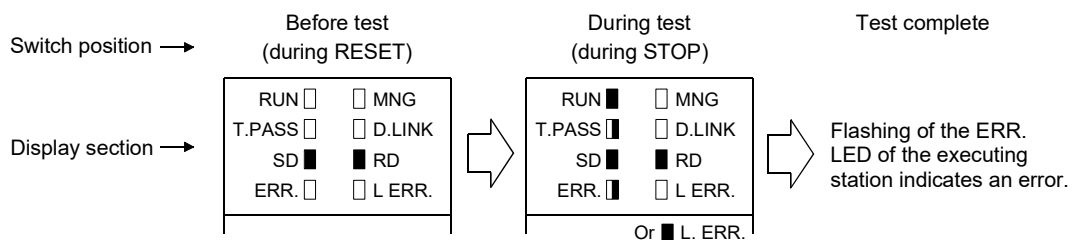

Upon detection of an error, the test will be terminated (abnormal termination).

<Possible causes of errors>

A loopback was executed because of a wiring error, a faulty optical fiber cable or abnormality was detected in other station.

- 1) If wiring is incorrect
Check the connections of IN and OUT connectors and other connectors. If an incorrect connection is found, connect properly.
- 2) If an optical fiber cable is faulty or another station is abnormal
Replace the defective cable or module.

REMARKS

The status during the test and the test result can be checked using link special registers or GX Developer.

Baton pass status (host)	SW0047	→ 1FH	: Offline test
Cause of baton pass interruption	SW0048	→ 2H	: Offline test
Offline test execution item/ faulty station (requesting side)	SW00AC	→ □□03H or □□04H	: Loop test
Offline test result (requesting side)	SW00AD	→ 0	: Normal

1 or larger : Error code

For details on how to check the error contents, refer to Chapter 8.

If two or more modules are installed, the testing status and the result of each module can be checked by adding 200H to the corresponding device number.

4.10 Network Diagnostics from GX Developer (Online Tests)

With the network diagnostic function of GX Developer, the line status can easily be checked and diagnosed.

Conduct network diagnostics by connecting GX Developer with a remote master station.

For a remote sub-master station and remote I/O station, the line status can be confirmed through the network diagnostics of the remote master station.

To conduct the network diagnostics, the network parameters (station number setting switches, mode setting switch, number of modules, network settings, and common parameters) must be set.

However, even if not all the parameters were set, the loop test can be performed while the T.PASS LED is on.

The network diagnostics function allows the diagnostics of the network module while maintaining it in the online status when a problem occurs during system operation.

The following table lists the tests that can be conducted for each network system:

Test item	Optical loop system	Coaxial loop system	Data link status of cyclic and transient transmissions	Reference section
Network test	○	○	Continue	Section 7.9
Loop test	○	×	Pause	Section 4.10.1
Setup confirmation test	○	○	Pause	Section 4.10.2
Station order check test	○	×	Pause	Section 4.10.3
Communication test	○	○	Continue	Section 4.10.4

○: Execution allowed ×: Execution not allowed

For details on the operations of each function, refer to the GX Developer Operating Manual.

The following screen is displayed when the network diagnostics is selected with GX Developer. Select the button for the network diagnostic item that will be conducted.

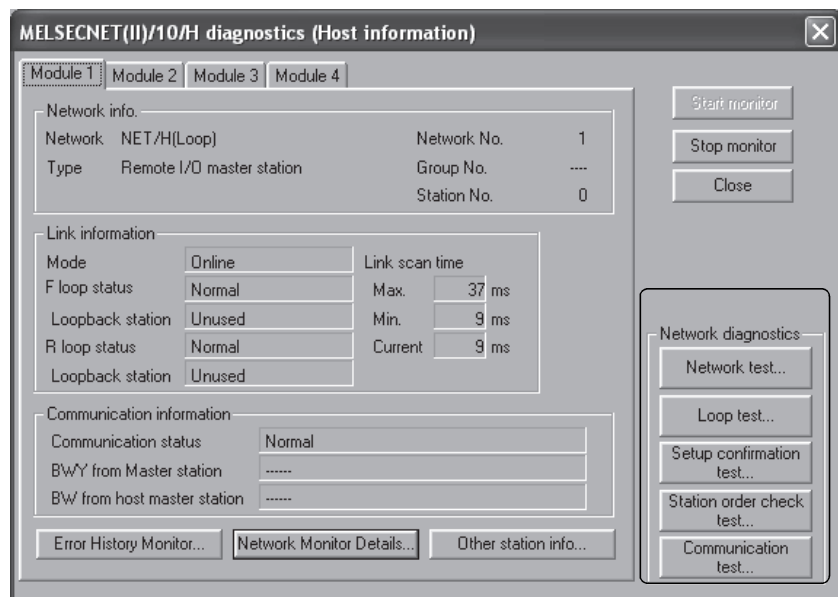

4.10.1 Loop test (optical loop system only)

This test checks the line status (forward loop or reverse loop) after all stations are connected to the optical loop system.

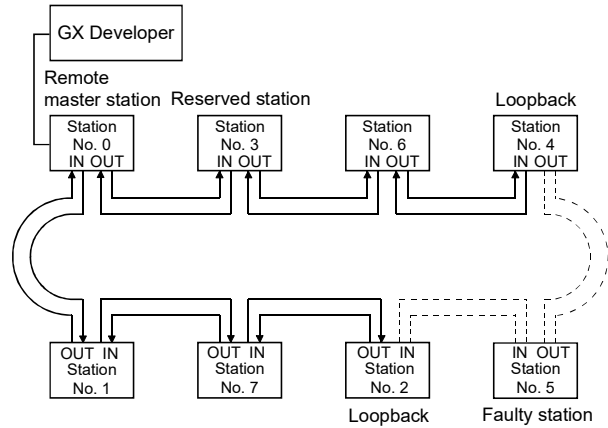

When the loop test is performed using GX Developer connected to the remote master station in the system above, where IN connector and OUT connector of the station number 5 are connected inversely, the following screen appears. The station number 5 is detected as a receive direction faulty station.

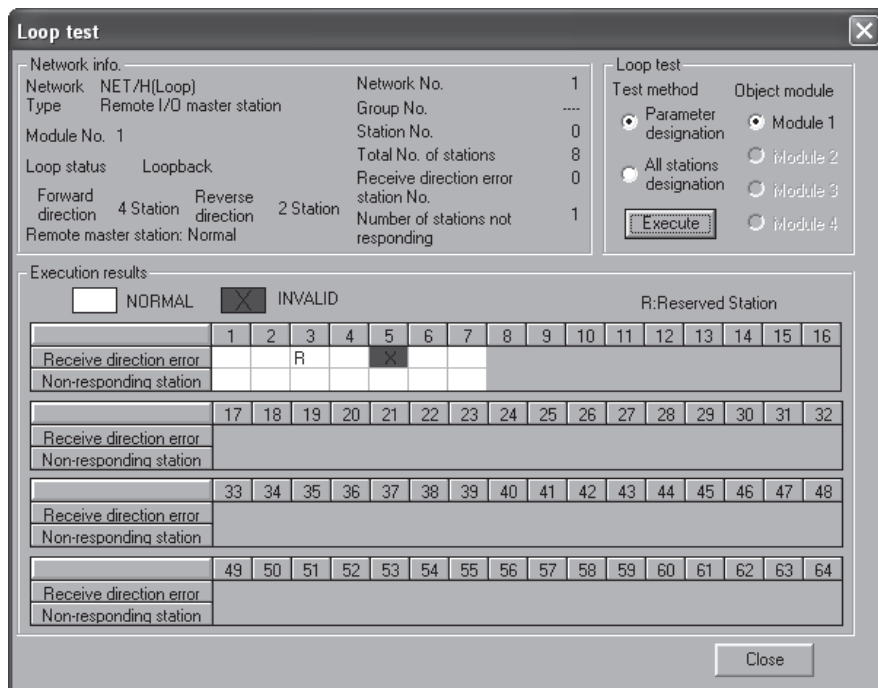

POINT

In the loop test, the wiring status is checked after the data link has been stopped. To check the wiring status without stopping the data link, use SW009C to SW009F. For details, refer to Section 8.2.10.

4.10.2 Setup confirmation test

This test checks the switch setting of a network module.

The following items can be checked.

- 1) Control station overlap status (This check is not performed on remote I/O network.)
- 2) Station number duplication status
- 3) Network No. consistency check (Whether the network number set for the station where GX Developer is connected matches the network number set in network parameter of the host station.)

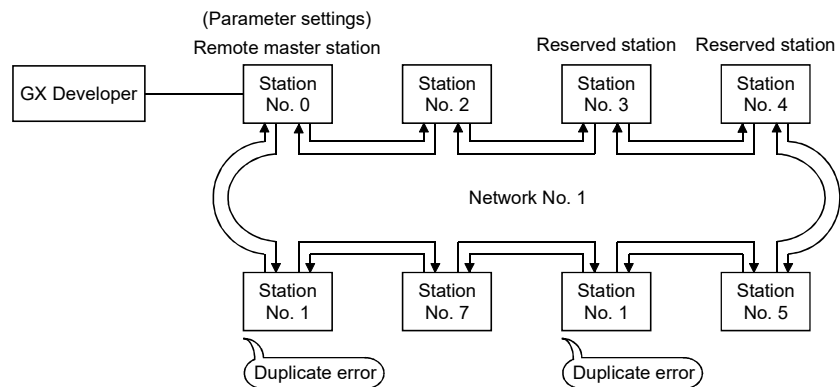

When the setup confirmation test is performed using GX Developer connected to the remote master station in the system above, the following screen appears.

The result shows that the station number 1 has a station No. duplication error.

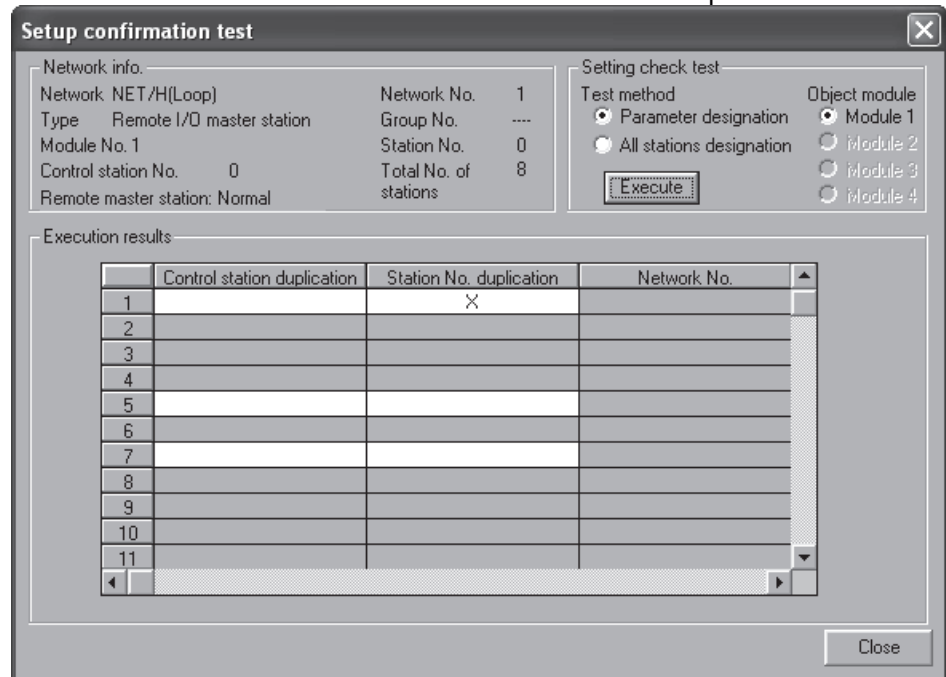

4.10.3 Station order check test (optical loop system only)

This test checks the order of connected stations in the optical loop system. The following table lists the correspondence between the loop status and the order of stations that can be checked in the test.

Loop status	Display
Forward and reverse loops	The station numbers connected in the direction of the forward loop from the host as well as the station numbers connected to the direction of the reverse loop from the host
Forward loop	Only the station numbers connected in the direction of the forward loop from the host
Reverse loop	Only the station numbers connected in the direction of the reverse loop from the host
Loop back	Only the station numbers connected in the direction of the forward loop from the host

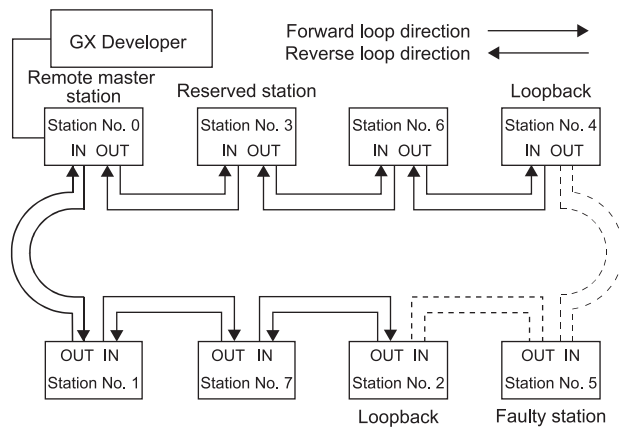

When the station order check test is performed using GX Developer connected to the remote master station in the system above, the following screen appears. The result shows that the loopback is performed in the stations, the station number 4 and 2, connected in the forward loop direction.

Station order check test

Network info.
 Network NET/H(Loop) Network No. 1
 Type Remote I/O master station Group No.
 Module No. 1 Station No. 0
 Loop status Loopback No. of stations 8
 Forward direction 4 Station Reverse direction 2 Station

Station order check test
 Test method: Parameter designation Object module: Module 1
 All stations designation Module 2
 Module 3
 Module 4

Execution results:

Own station	1	2	3	4	5	6	7	8	9	10	11	12	13	14	15	16	
Forward loop direction from own station	0	6	4	2	7	1											
		17	18	19	20	21	22	23	24	25	26	27	28	29	30	31	32
		33	34	35	36	37	38	39	40	41	42	43	44	45	46	47	48
		49	50	51	52	53	54	55	56	57	58	59	60	61	62	63	64

Own station	1	2	3	4	5	6	7	8	9	10	11	12	13	14	15	16	
Reverse loop direction from own station																	
		17	18	19	20	21	22	23	24	25	26	27	28	29	30	31	32
		33	34	35	36	37	38	39	40	41	42	43	44	45	46	47	48
		49	50	51	52	53	54	55	56	57	58	59	60	61	62	63	64

Station No. 3 is not displayed because it is a reserved station.

4.10.4 Communication test

This test checks whether communications is normally performed between the host station and a communication-target station (specified with the network number and station number).

If the communication-target station is in another network, the relay network number and station number are displayed and the routing parameter settings can be checked.

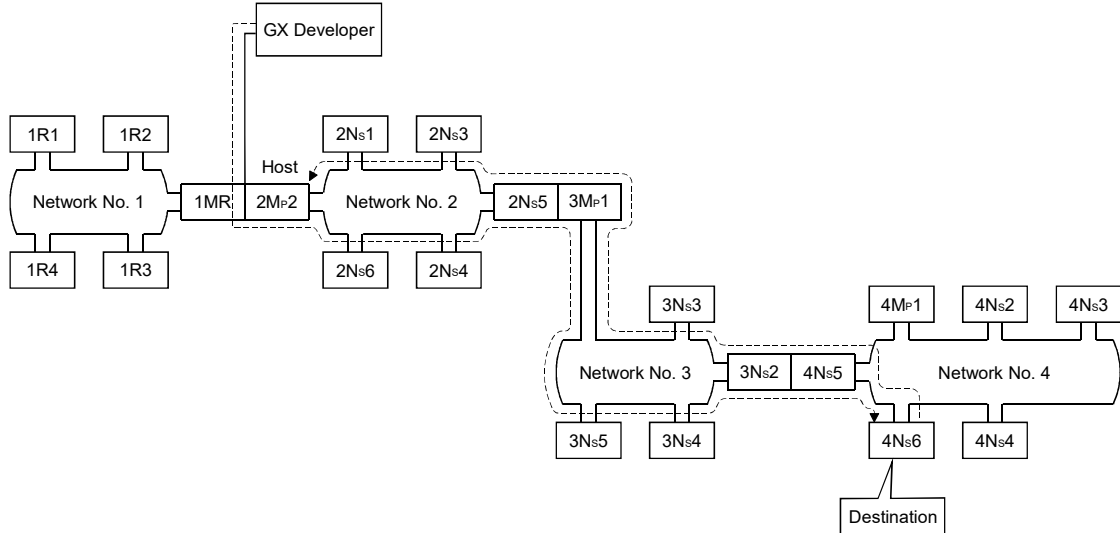

When the communication test is performed from GX Developer connected to the 2Mp2 in network number 2 to the 4Ns6 in network number 4 in the system above, the following screen appears. The result shows that communications between two stations is normal.

5 PARAMETER SETTINGS

To operate a remote I/O network, parameters must be set up for the CPU module on the remote master station and remote I/O modules on remote I/O stations accordingly. Settings ranging from MELSECNET/H type selection to application function details can be configured with parameters.

The following is a flow chart of the settings.

(1) Parameter settings for the remote master station

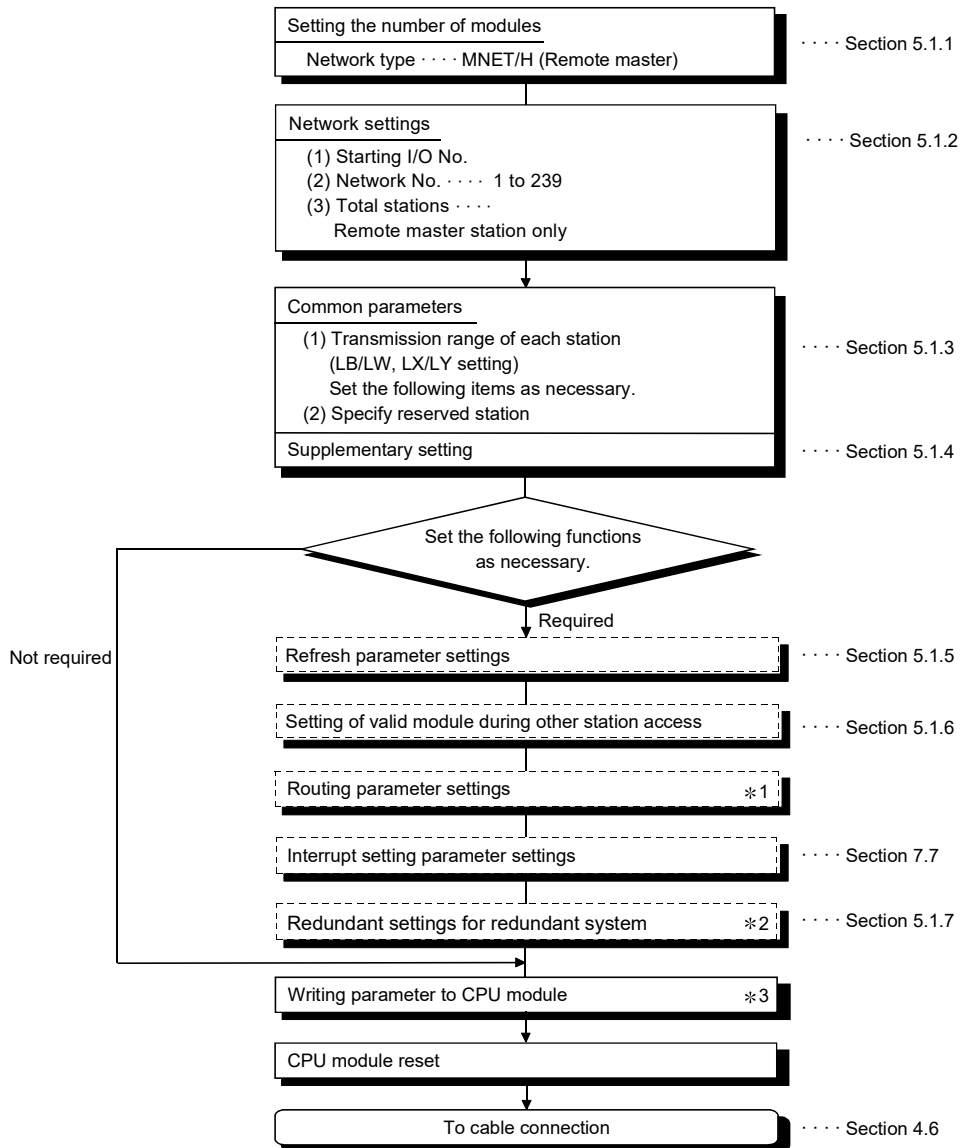

*1: Refer to the Q corresponding MELSECNET/H Network System Reference Manual (PLC to PLC network) for details.

*2: Make the settings only when using the redundant system.

*3: For the redundant system, write the parameter to the CPU module of the control system.

5

(2) Parameter settings for a remote I/O station

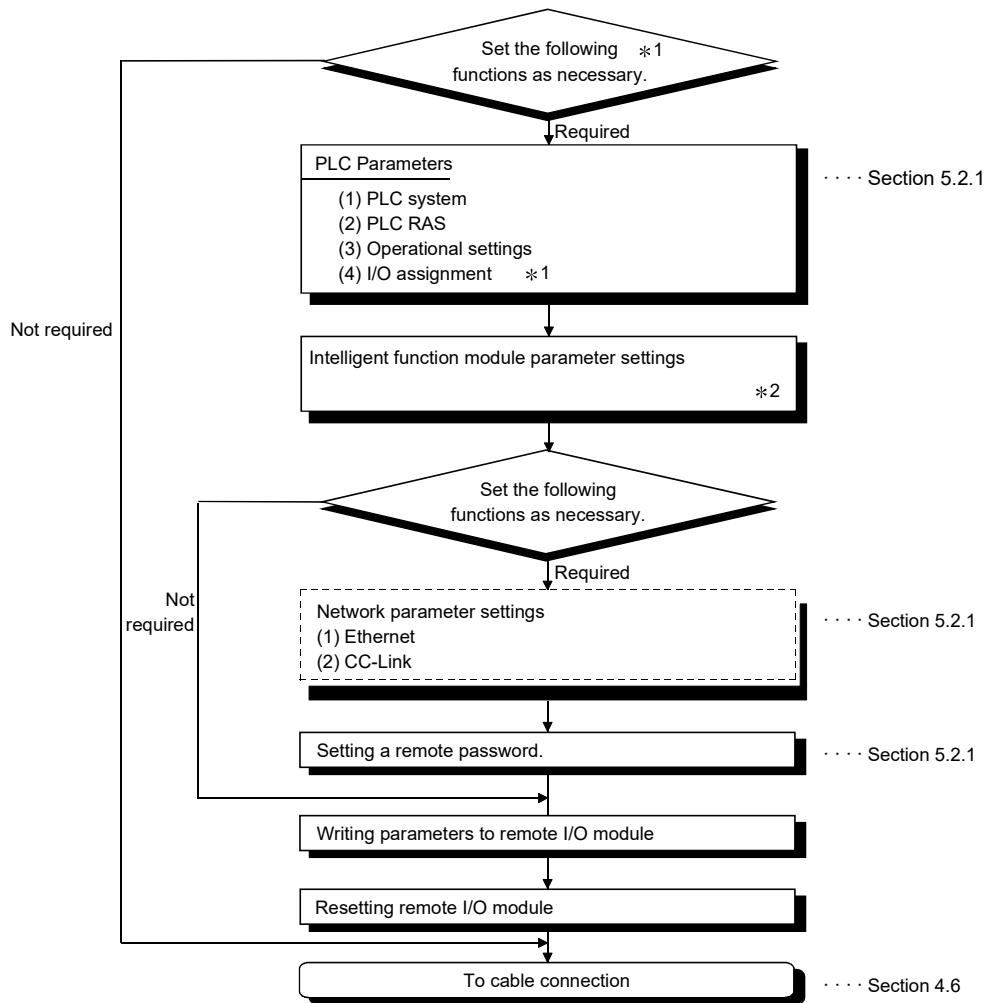

POINT
1) If no parameters are written to the remote I/O station, operation is performed using the default settings. (Refer to Section 5.2.1)
2) Resetting the CPU module of the remote master station or changing the status from STOP to RUN resets remote I/O stations which satisfy the following conditions: <ul style="list-style-type: none"> • The PLC parameter/network parameter or remote password of a remote I/O station was corrected but not yet effective due to a reason such as reset of the remote I/O station. • A stop error has occurred. (Refer to section 8.3.3.)
3) Even if only one of the following settings is corrected, all the parameters are written to the remote I/O module: PLC parameters, intelligent function module parameters, network parameters, and remote password

*1: The following settings can be performed for the I/O assignment.

- 1) Input module for I/O response time.
- 2) Output module error time output mode.
- 3) I/O assignment
- 4) Setting switches for intelligent function modules.

*2: Refer to the intelligent function module user's manual for details about intelligent function module parameters.

Table 5.1 Remote master station network parameter setting items

Parameter setting item	Network station type	Remote master station	Reference section
Settings with the network module		—	Section 4.3
Station number (STATION No.)		●	Section 4.3.1
Mode (MODE)		●	Section 4.3.2
Settings with GX Developer		—	
Setting the number of modules (network type)		●	Section 5.1.1
Network settings		—	Section 5.1.2
Starting I/O No.		●	Section 5.1.2 (1)
Network No.		●	Section 5.1.2 (2)
Total stations		●	Section 5.1.2 (3)
Group No.		△	Section 5.1.2 (4)
Mode		●	Section 5.1.2 (5)
Common parameters		—	Section 5.1.3
Send range of each station (LX/LY settings)		●	Section 5.1.3 (1)
Send range of each station (LB/LW settings)		△	Section 5.1.3 (2)
Specify reserved station		△	Section 5.1.3 (3)
Supplementary settings		—	Section 5.1.4
Constant link scan		△	Section 5.1.4
Maximum No. of returns to system stations in 1 scan.		▲	
Multiplex transmission designation		△	
Block send data assurance per station		△	
Block receive data assurance per station		△	
END asynchronous settings		△	
Transient settings		▲	
Refresh parameters		▲ *3 *4	Section 5.1.5
Valid module during other station access		△	Section 5.1.6
Interrupt settings		△	Section 7.7
Redundant settings		●	Section 5.1.7
Routing parameters		△	*5

●: Always set ▲: Default setting exists △: Set as needed ×: Setting not required

*3: Default values are not set for LX/LY. Set the refresh parameters.

*4: Default values are preset for LB/LW.

The CPUs other than the Universal model QCPU may operate even if refresh parameters have not been set.

For the operation and precautions, refer to Section 5.1.5 (3).

*5: For details, refer to the Q Series MELSECNET/H Network System Reference Manual (PLC to PLC Network).

REMARKS

Always write network parameters to the remote master station.

Table 5.2 Remote I/O station PLC parameter setting items

Parameter setting item	Network station type	Remote I/O station	Reference section
PLC system		—	Section 5.2.1
Points occupied by empty slot		▲	
Module synchronization		▲	
PLC RAS		—	Section 5.2.1
Operating mode when there is an error		▲	
Error check		▲	
Operational settings		—	Section 5.2.1
Remote I/O switch setting		△	
Assignment method		△	
Forwarding parameter between devices		△	
I/O assignment		—	Section 5.2.1
I/O Assignment		△	
Standard setting		△	

●: Always set ▲: Default setting exists △: Set as needed ×: Setting not required

Table 5.3 Remote I/O station network parameter setting items

Parameter setting item	Network station type	Remote I/O station	Reference section
Ethernet		△	Section 5.2.1
CC-Link		△	Section 5.2.1

●: Always set ▲: Default setting exists △: Set as needed ×: Setting not required

Table 5.4 Remote I/O station remote password setting items

Parameter setting item	Network station type	Remote I/O station	Reference section
Password setting		△	Section 5.2.1
Password active module settings		△	Section 5.2.1

●: Always set ▲: Default setting exists △: Set as needed ×: Setting not required

Refer to the intelligent function module user's manual for details about intelligent function module parameters.

5.1 Remote Master Station Parameter Setting

The remote master station sets the network parameters to the CPU module.

5.1.1 Setting the number of modules (Network type)

Set the network type and the station type for each module.

No. of mountable modules is the maximum number of mountable network modules with CC-Link IE Controller Network.

Note, however, that there are restrictions on the number of network modules that can be mounted, depending on the CPU module used. (Refer to Section 2.5.)

Select the remote master station for the MELSECNET/H network system.

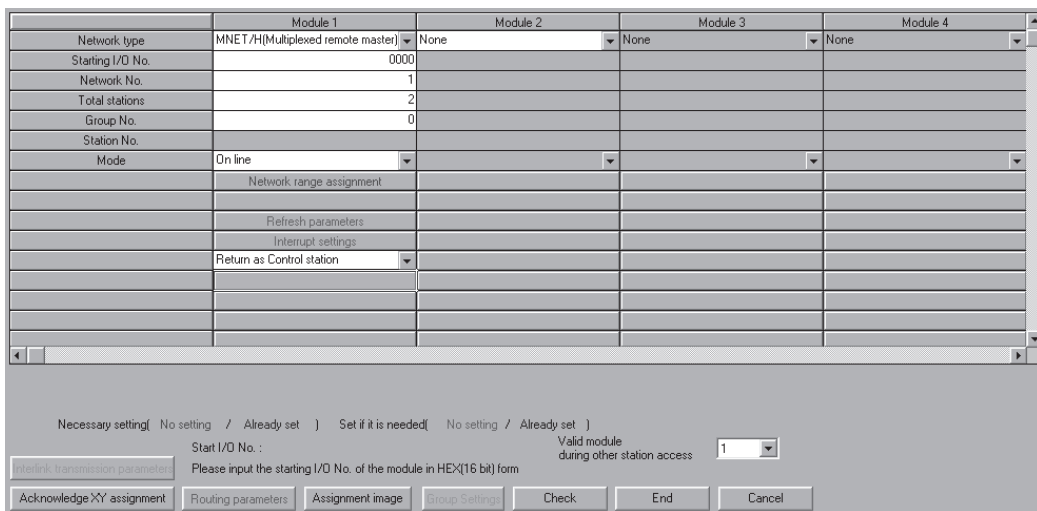

(1) Selection type

Select the following item.

- MNET/H (Remote master): When the remote master station is specified
- MNET/H (Multiplexed remote master): When the multiplexed remote master station is specified
- MNET/H (Multiplexed remote sub-master): When the multiplexed remote sub-master station is specified

(2) Precautions

- If a QnA/A series MELSECNET/10 network module is erroneously connected to a MELSECNET/H remote I/O network, the network system will operate as follows.
 - If the remote master station is a MELSECNET/H network module, MELSECNET/10 network modules on remote I/O stations will be disconnected from the network.
 - If the remote master station is a MELSECNET/10 network module, MELSECNET/H network modules on remote I/O stations will be disconnected from the network.

5.1.2 Network settings

These parameters are used to configure the MELSECNET/H network.

Set the starting I/O No., network No., total number of (slave) stations, group No. and mode for each of the module model names set in the number of modules settings.

(1) Starting I/O No.

Set the start I/O No. to which the module is loaded in 16-point units in hexadecimal for each applicable network module.

For example, set 130 when the network module is loaded onto X/Y130 to 14F.

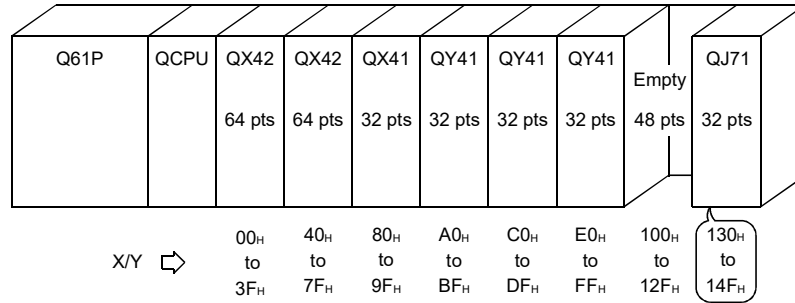

(a) Valid setting range

0_H to 0FE0_H

(b) Precaution

Unlike the setting method for the AnUCPU (where the higher two digits of the 3-digit value should be set), here all three digits should be set as is.

(2) Network No.

Set the network number to which the applicable network module is connected.

(a) Valid setting range

1 to 239

(3) Total stations

Set up the total number of multiplexed remote sub-master stations, remote I/O stations, and reserved stations in a single network.

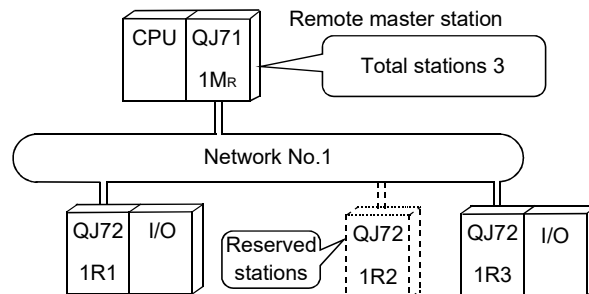

(a) Valid setting range

1 to 64

(4) Group No. (available for multiplexed remote master/sub-master station only)

Set the group No. to send data simultaneously to other stations in transient transmission.

(a) Valid setting range

0 : No group specification (default)

1 to 32 : Group No.

(5) Mode

Set the operation mode of the network module.

The mode selection with this parameter becomes valid when the mode setting switch of the network module is set to 0 or 4.

Selection item	Description
Online (Default)	This mode performs normal operations (the station returns to the network). Starts data communication at startup and executes automatic return operation. etc.
Offline	This mode stops operations (disconnecting the station). Baton pass and data communication with other stations are not executed.
Forward loop test	This mode is to select the hardware test operation that checks the connection status and the optical fiber cables on the forward loop side. (Remote master station only) For details on how to conduct the hardware test, refer to Section 4.9.1.
Reverse loop test	This mode is to select the hardware test operation that checks the connection status and the optical fiber cable on the reverse loop side. (Remote master station only) For details on how to conduct the hardware test, refer to Section 4.9.1.

(6) Parameter setting example

The following is an example for system parameter settings including remote master station (remote I/O network) and controlling station (PLC to PLC network).

(System configuration)

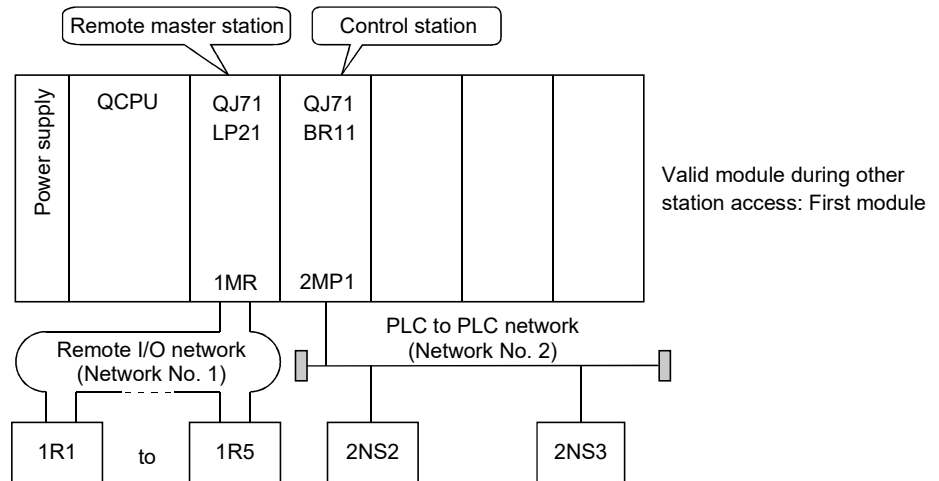

(Screen settings)

	Module 1	Module 2
Network type	MNET/H(Remote master)	MNET/H mode (Control station)
Starting I/O No.	0000	0020
Network No.	1	2
Total stations	5	3
Group No.		0
Station No.		
Mode	On line	On line
	Network range assignment	Network range assignment
	Refresh parameters	Refresh parameters
	Interrupt settings	Interrupt settings
		Return as control station

5.1.3 Common parameter

The common parameters set the LB, LW, LX and LY cyclic transmission ranges that allows sending and receiving between a remote master station and remote I/O stations in a network. Common parameters only need to be set for the remote master station.

(1) LX/LY setting

I/O signals (X, Y) of each remote I/O station are transferred to the CPU module via link devices (LX, LY) of the remote master station for control in the CPU module.

The I/O signals (X, Y) are assigned to the remote master station's link devices (LX, LY) in the LX/LY setting.

The LX setting is made for transferring the input signal (X) information of remote I/O stations to the link devices of the remote master station.

The LY setting is made for transferring the link device (LY) information of the remote master station to the output signal (Y) area of the remote I/O stations.

Set the same device points for the remote master and each remote I/O station in the LX/LY setting.

(Screen setting)

StationNo.	M station -> R station						M station <- R station					
	Y			Y			X			X		
	Points	Start	End	Points	Start	End	Points	Start	End	Points	Start	End
1	256	1000	10FF	256	0000	00FF	256	1000	10FF	256	0000	00FF
2	256	1100	11FF	256	0000	00FF	256	1100	11FF	256	0000	00FF
3	256	1200	12FF	256	0000	00FF	256	1200	12FF	256	0000	00FF

(Assignment)

An LX assignment is illustrated below.

The following is an example where LX of the master module is automatically refreshed to the area starting from X1000 in the CPU module.

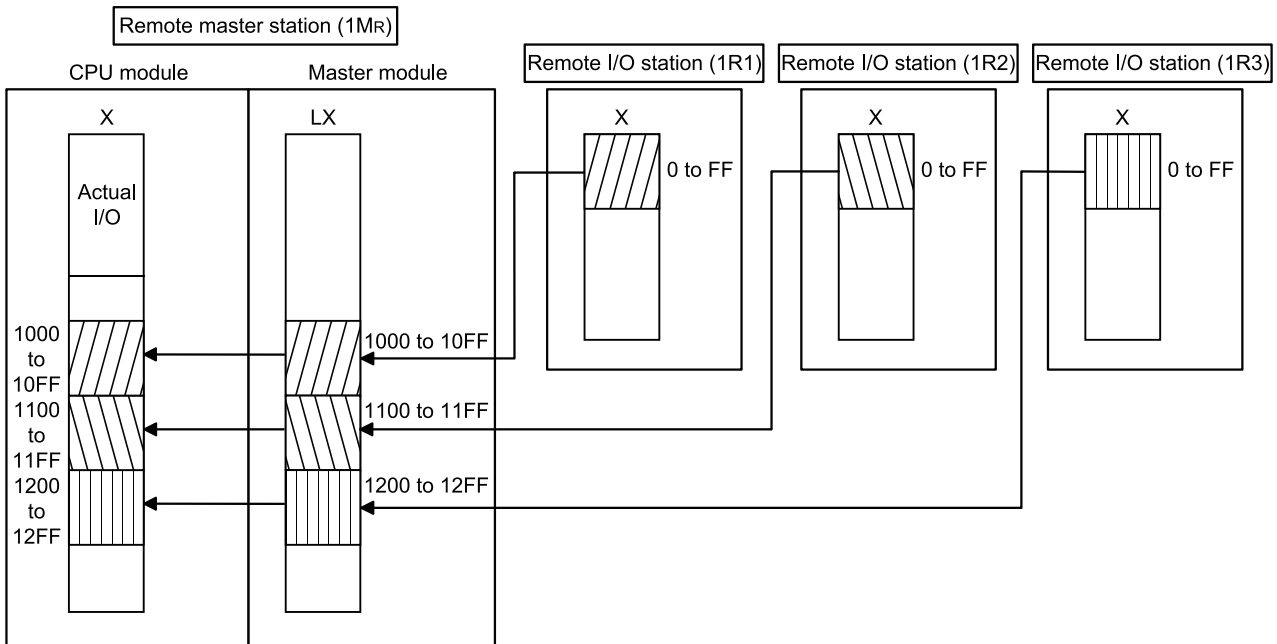

REMARKS

The link device (LX, LY) data of the remote master station are refreshed to the internal user devices (e.g. X, Y) of the CPU module to be used in sequence programs.

To refresh these data to the CPU module's input (X) or output (Y) area, assign them to the area after the actual I/O.

For details on the link refresh, refer to Section 5.1.5.

POINT

- (1) Set the setting for the remote master station side to the input/output number of the remote I/O station module that is mounted.

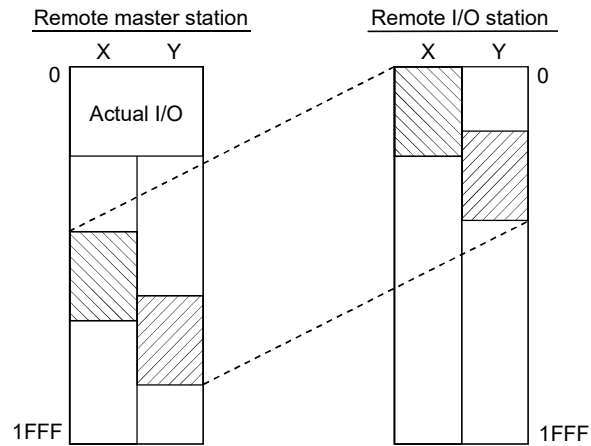

If there is an error in the mounting condition, malfunctioning will occur.

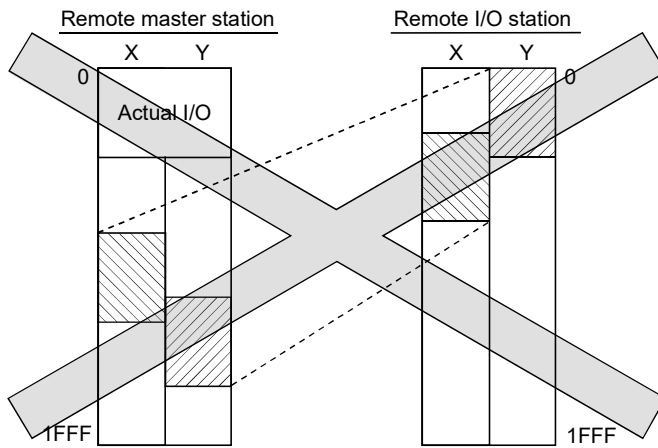

- (2) It is possible to reduce the number of links if the mounting of is consolidated into groups of input modules, intelligent function modules and I/O modules.

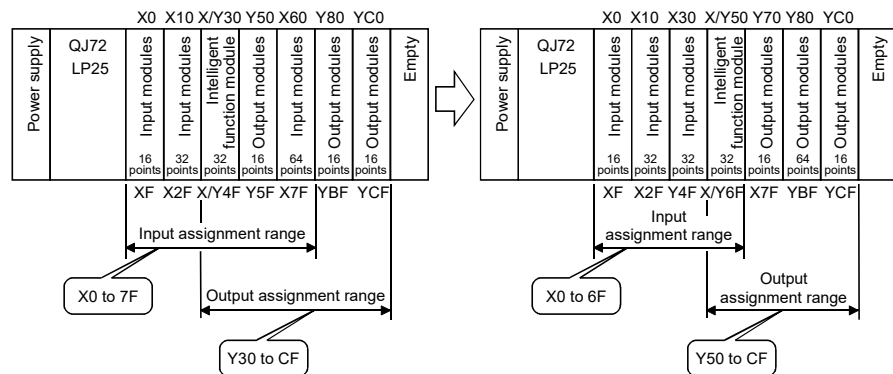

(2) LB/LW setting

The LB/LW data on each remote I/O station are transferred to the CPU module via LB/LW of the remote master station for control in the CPU module.

In the LB/LW setting, set the area ranges for sending data from the remote master station to each remote I/O station and for receiving data from each remote I/O station to the remote master station.

In addition, if intelligent function parameters (automatic refresh setting) are set to an intelligent function module on a remote I/O station from GX Configurator, the buffer memory of the intelligent function module can be read/written from the remote master station using LW.

For details, refer to Section 3.2.1.

(Screen setting)

StationNo.	M station > R station			M station < R station			M station > R station			M station < R station		
	B			B			W			W		
	Points	Start	End	Points	Start	End	Points	Start	End	Points	Start	End
1							128	0000	007F	128	1000	107F
2							128	0080	00FF	128	1080	10FF
3							128	0100	017F	128	1100	117F

(Allocation)

An LW assignment is illustrated below.

The following is an example where LW of the master module is link refreshed to the area starting from W0 in the CPU module.

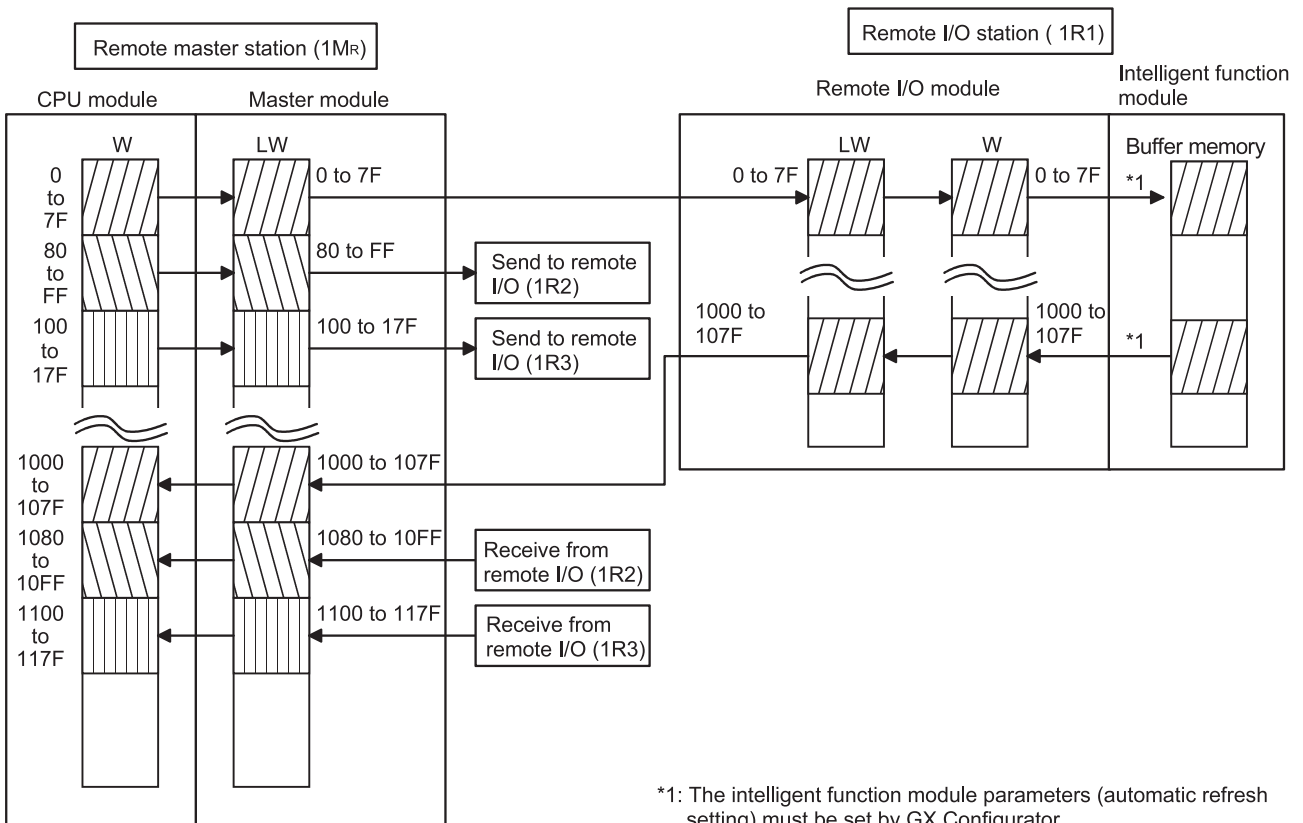

REMARKS

The link device (LB, LW) data of the remote master station are refreshed to the internal user devices (e.g. B, W) of the CPU module to be used in sequence programs.

For details of the link refresh, refer to Section 5.1.5.

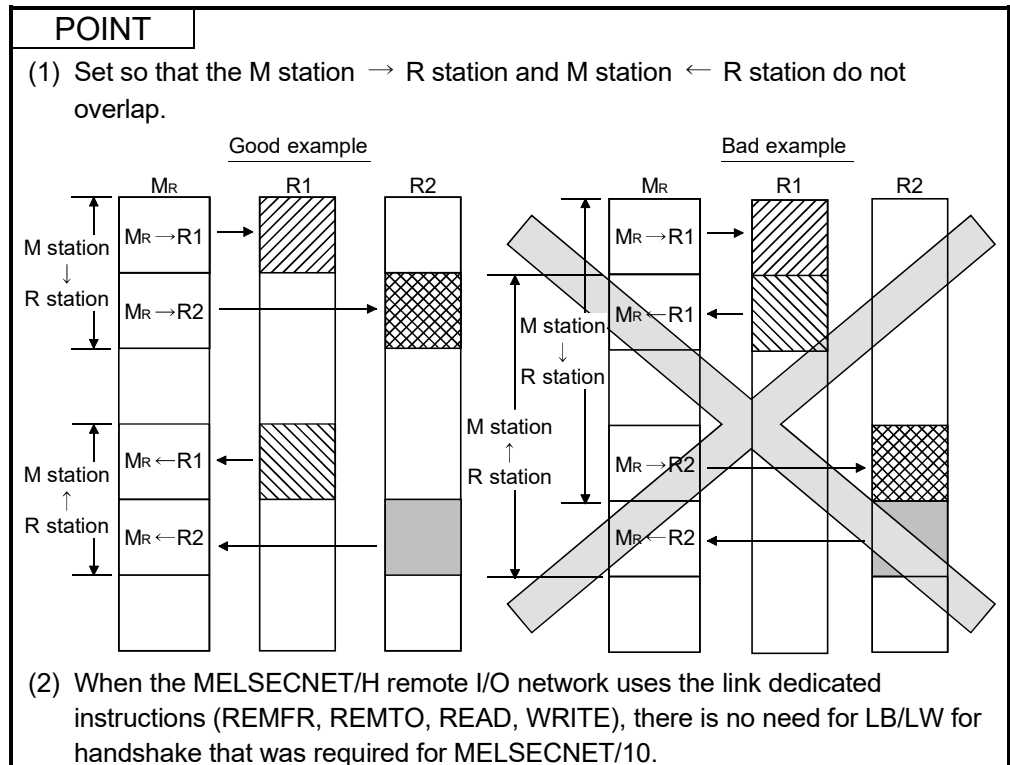

(3) Reserved station specification

This function enables the stations that will be connected in the future not to be handled as stations with communication errors. (These stations are not actually connected, but they are included in the total number of stations (slave) in the network.)

Since reserved stations do not affect scan time, full performance can be realized even when they remain reserved.

(4) Remote sub-master station

Since the multiplexed remote master station must recognize the station No. of the multiplexed remote sub-master station, set the station No. of the multiplexed remote sub-master station in the network range assignment screen of the multiplexed remote master station.

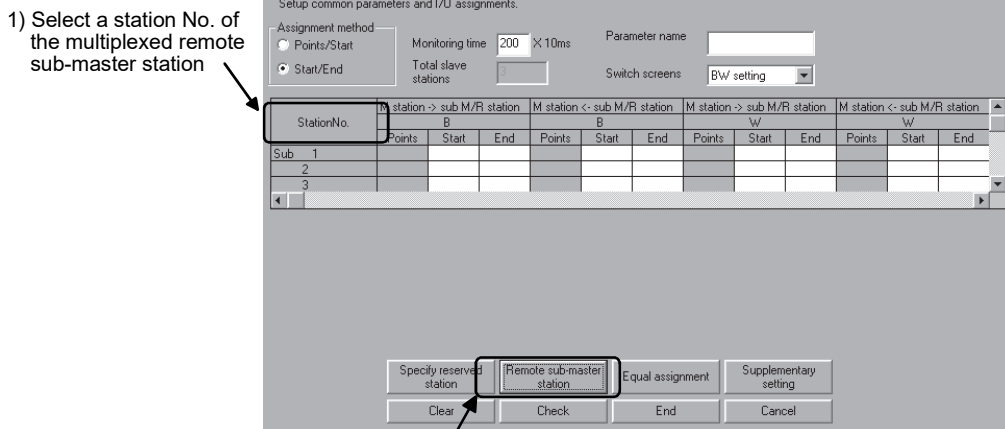

2) After selecting a station No. of the multiplexed remote sub-master station, click the button to finish the settings. When the settings are completed, "Sub" is displayed on the station No. box.

POINT

In the case of the multiplexed remote I/O network for redundant system, set the link devices in the tracking settings in the redundant parameters to update the link devices between the multiplexed remote master station and multiplexed remote sub-master station. (The set link devices are tracked from the control system to the standby system via the tracking cable.)

On the network range assignment screen, do not set the devices between the multiplexed remote master station and multiplexed remote sub-master station.

5.1.4 Supplementary settings

The supplemental settings are included in common parameter settings to provide more precise usage. Keep the default settings for normal use.

Common parameters supplemental are only for remote master stations.

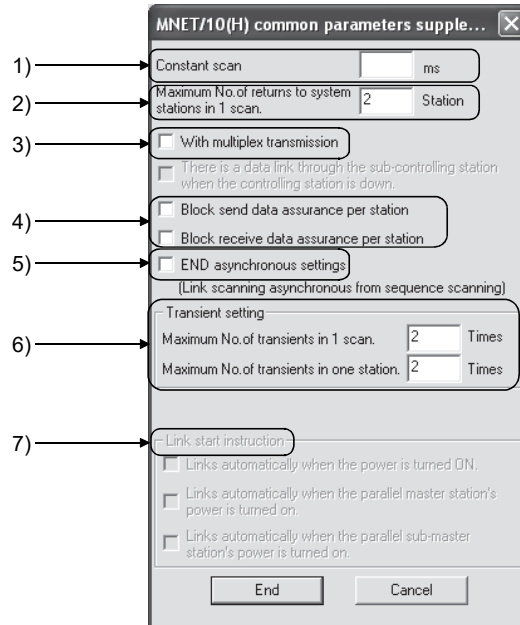

[Setting items]

1) Constant scan

The constant link scan function is used to maintain the link scan time constant.

If the response time is long for the transient transmission function, setting the constant link scan function may reduce the response time. Set a value in the following range to use a link scan time:

Setting time	Constant link scan
Blank	Not executed (default)
1 to 500 ms	Executed using the set time

- 2) Maximum No. of returns to system stations in 1 scan (refer to Section 3.2.2)
Set the number of faulty stations that can return to the network in one link scan.
 - Valid number of stations : 1 to 64 stations
 - Default : 2 stationsSince link scan time may be extended when a station error occurs if the number of stations has been increased in the settings, carefully change the settings.

- 3) With multiplex transmission (refer to Section 7.4)
Set this item when executing the multiplex transmission function.
The multiplex transmission function is used when both the forward and reverse loops are in the normal status to speed up the transmission rate using both loops at the same time.
This setting can be made when there are four or more remote I/O stations.
 - Default: No multiplex transmission

- 4) Block send/receive data assurance per station
Set these items when executing the link data separation prevention per station in the cyclic transmission.
This allows multiple word data manipulation without interlocks.
However, the separation prevention *1 is valid only for the refresh processing between the CPU module and the master module.
 - Default: No setting for both send and receive*1: The separation prevention refers to a prevention of link data with double word precision (32 bits), such as the current value of the positioning module, from being separated into new data and old data in one word (16 bits) units due to the cyclic transmission timing.

- 5) END asynchronous settings (refer to Section 3.3.1 (2) (b).)
Enable this setting when link scans should be performed asynchronously with sequence scans.
 - Default: No END asynchronous settings

6) Transient setting *2

Set the execution conditions for the transient transmission.

"Maximum No. of transients in 1 scan"

Set the number of transients (total for one entire network) that a single network can execute in one link scan.

- Valid setting count : 1 to 255 times
- Default : 2 times

"Maximum No. of transients in one station"

Set the number of transients that a single station can execute in one link scan.

- Valid setting count : 1 to 10 times
- Default : 2 times

*2: When making the transient setting, use the following network module and GX Developer:

- Remote master and remote I/O stations: First 5 digits of serial No. is "07102" or later.
- GX Developer: GX Developer Version 8.29F or later

POINT
<p>(1) Transient request processing may be prolonged in a system where transient requests are made frequently (e.g. a system including a remote I/O station to which a GOT is mounted). In such a case, make the following setting.</p> <p>(a) Parameter setting for the remote master station Increase the value set in No. of transients. Doing this enables concurrent execution of many transient requests (during one scan).</p> <p>(b) Setting on the remote master station (CPU module)</p> <p>1) Execute the COM instruction. Transient requests are processed when the remote master station executes the COM instruction. (This is effective when the scan time of the remote master station is long.)</p> <p>2) Secure communication processing time. In the END processing of the remote master station, the processing time for transient requests is secured. (This is effective when the scan time is short.)</p> <ul style="list-style-type: none">• For the High Performance model QCPU, Process CPU, and Redundant CPU, set it by the special register SD315.• For the Universal model QCPU, set it by the service processing setting of the PLC parameter (PLC system) of GX Developer. <p>Either of the above 1) or 2) can reduce the wait time for transient request processing on the remote master station even if multiple remote I/O stations issue transient requests.</p> <p>(2) Although the above (1) can reduce the transient request processing time, it may affect the process as described below. Adjust each set value shown in (1) to a value suitable for the system being used.</p> <p>(a) Link scan time of MELSECNET/H When transient requests are issued from multiple stations at the same time, the link scan time may be temporarily prolonged.</p> <p>(b) Scan time of the remote master station (CPU module) The scan time may be prolonged by execution of the COM instruction or by securing the communication processing time.</p>

- 7) Link start instruction
For future expansion. Cannot be set at present time.

5.1.5 Refresh parameters

The refresh parameters are used to transfer the link device data (LB, LW, LX, LY) of the network module to the devices (X, Y, M, L, T, B, C, ST, D, W, R, ZR) of the CPU module for operation of the sequence programs.

By eliminating the link refresh of those link devices that are not used by the sequence programs, the scan time can also be reduced.

Because it is not necessary to transfer the link devices to different devices with the sequence programs, the number of program steps is reduced and easy-to-understand programs can be created.

POINT

Note that there are no default settings for LX/LY points in the refresh parameters. A CPU that does not have the number of points set cannot input and output network link device LX/LY.

Refresh parameters

(Refresh parameter setting screen)

The assignment status of the above refresh parameters can be checked with the assignment image diagram.

The assignment image diagram shows the device assignments made between the CPU module and the modules set for the No. of module setting.

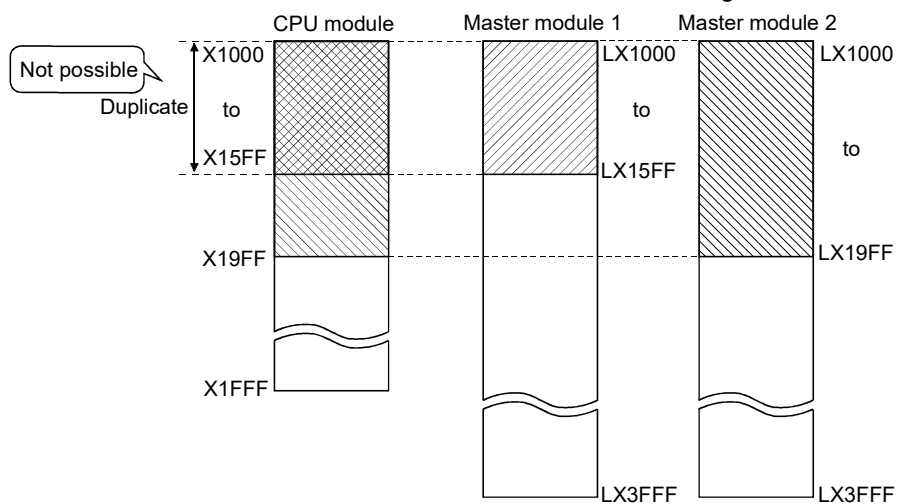

Using the assignment image diagram, assignment errors and duplicate settings between the modules can also be checked.

It is a convenient tool to view the assignment status when setting or changing the network refresh parameters.

Assignment image

(Refresh parameter setting screen)

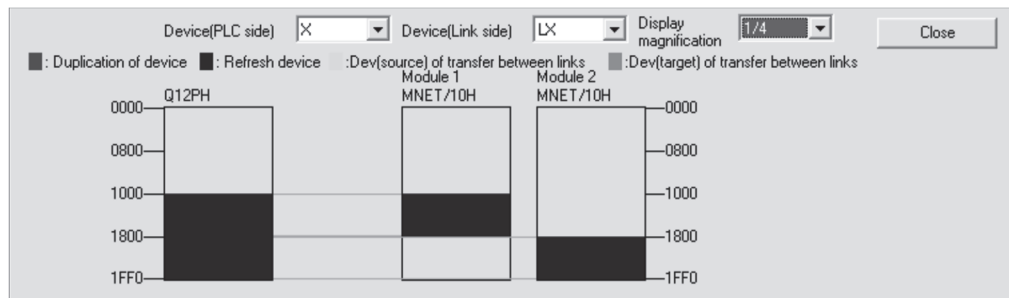
**POINT**

The assignment image diagram can display schematic images of CC-Link IE Controller Network, CC-Link IE Field Network and MELSECNET/H (network modules on controller networks, PLC to PLC networks, and remote I/O networks). Avoid any duplicate settings of the programmable-controller-side devices that are used for the following.

- Auto refresh parameters of CC-Link modules
- Refresh parameters of CC-Link IE Controller Network modules, CC-Link IE Field Network modules, and MELSECNET/H network modules
- Auto refresh parameters of intelligent function modules
- Auto refresh using the CPU shared memory in the multiple CPU system
- I/O numbers used for I/O modules and intelligent function modules

1) Assignment method

Select the device range input method from either Points/Start or Start/End.

- Default: Start/End

2) Transient transmission error history status

Select whether to overwrite or hold the error history.

- Default: Overwrite

3) Transfer settings on the Link side and the PLC side

Select the device names from the following:

Link side : LX, LY, LB, LW

PLC side : X, Y, M, L, T, B, C, ST, D, W, R, ZR

However, if the link side is LX, any of C, T and ST cannot be selected on the CPU side.

Set the values for Points/Start/End in 16-point units.

4) **Default** button

Select this button to automatically assign the default link devices according to the number of installed modules.

5) **Check** button

Select this button to check if there are any duplicate parameter data settings.

- 6) button

Click this button to return to the network setting screen after completing the data settings.

REMARKS

[Random cyclic] is for future use. An error will not occur even if it is selected, but no processing will be performed.

POINT		
<p>Either of the following settings must be made to use the entire device range (16K points) of LB/LW.</p> <ol style="list-style-type: none"> 1) Change the number of B/W device points. (Refer to the following example.) 2) Make the refresh parameter settings so that B/W and other devices will be assigned as the refresh destination devices of LB/LW. (Refer to Section 5.1.5.) 		
<p>[Example]</p> <p>To change [Device] of [PLC parameter] in order to use all 16K points of the LB and LW device range</p> <p>Note the following points when assigning device points:</p> <ol style="list-style-type: none"> 1) The total number of device points is 29K words for the High Performance model QCPU, Process CPU, Redundant CPU, and Universal model CPU. 2) The total number of bit devices must be 64K bits. <p>[In the case of Q25HCPU]</p>		
	[Default]	[After change]
Input relay	X 8K	8K
Output relay	Y 8K	8K
Internal relay	M 8K	8K
Latch relay	L 8K	4K
Link relay	B 8K	16K
Annunciator	F 2K	2K
Link special relay	SB 2K	2K
Edge relay	V 2K	2K
Step relay	S 8K	8K
Timer	T 2K	2K
Retentive timer	ST 0K	0K
Counter	C 1K	1K
Data register	D 12K	4K
Link register	W 8K	16K
Link special register	SW 2K	2K
Word device total	26.0K	26.0K
Bit device total	44.0K	48.0K
Device total	28.8K	29.0K

[Default]

[After change]

(1) Concept of the link refreshing

(a) Link refresh ranges

The ranges that are set in Refresh parameters and that are set with common parameters are refreshed.

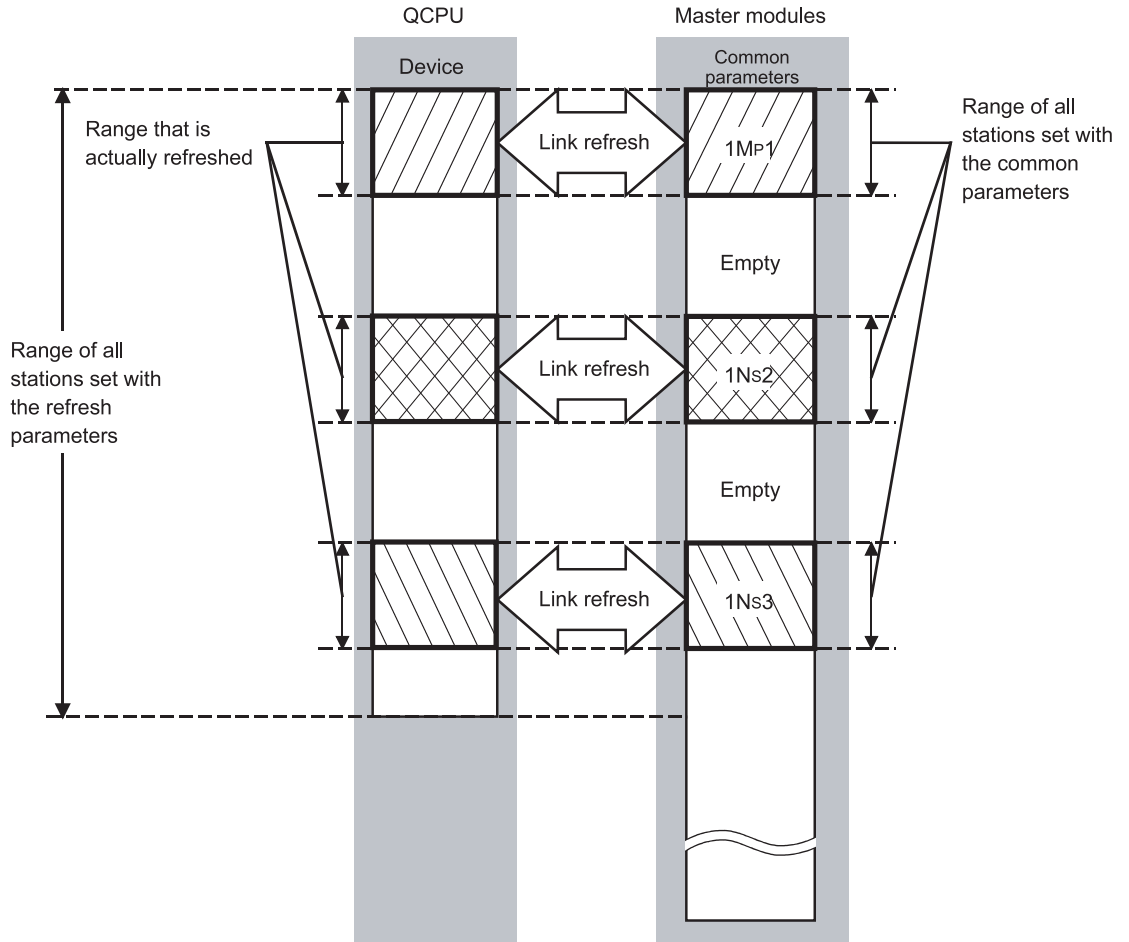

(b) Devices for which link refreshing can be executed

64 transfer settings (LX, LY, LB, LW), one SB transfer setting and one SW transfer setting can be performed for each master module.

It is possible to transfer to different devices.

SB, LB, B, LX, LY, X, Y, M, L, T, C and ST can be set in 16-point units, and SW, LW, W, D, R and ZR can be set in one-point units.

[List of devices for which the refresh combination transfer can be executed]

Setting item	Devices for which transfer is allowed	
	Link side device	PLC side device
SB transfer	SB	SB
SW transfer	SW	SW
Transfer 1	LX, LY, LB, LW	X, Y, M, L, T, B, C, ST, D, W, R, ZR*1
:	:	:
Transfer 64	LX, LY, LB, LW	X, Y, M, L, T, B, C, ST, D, W, R, ZR*1

*1: C, T or ST cannot be selected as the refresh destination of LX.

(2) How to set the refresh parameters

(a) Automatic setting with the **Default** button

- 1) When B/W points set in [Device] under [PLC parameter] are 8K points or more (6K points or more when three modules are mounted) Link devices are assigned as shown below.

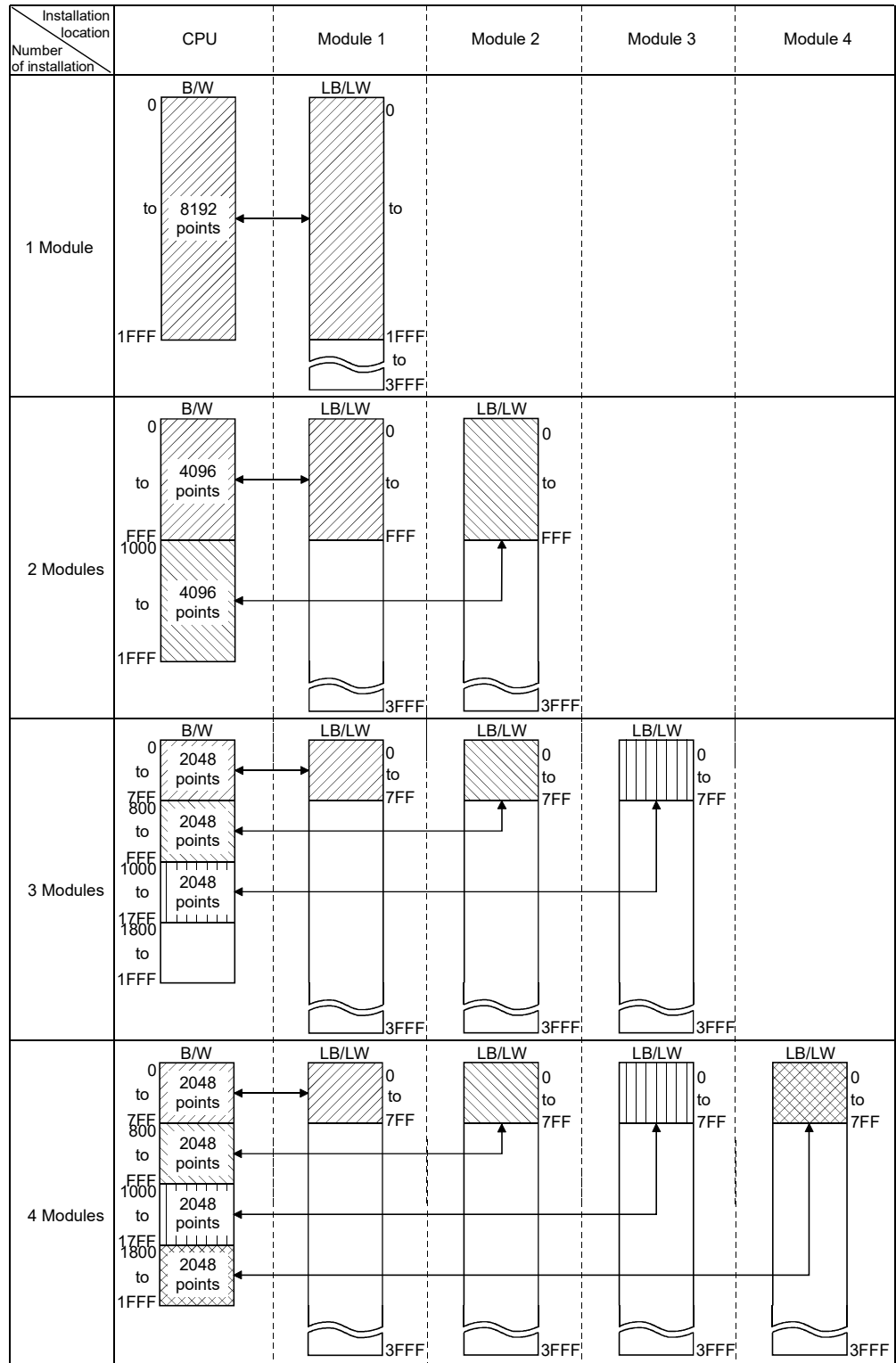

- 2) When B/W points set in [Device] under [PLC parameter] are less than 8K points (less than 6K points when three modules are mounted) Link devices equivalent to the B/W points set in [Device] are assigned, up to the following points for each module.

No. of modules	Maximum points assignable per module
1	B/W points set in [Device]
2	4K points
3	2K points
4	

Example: When B/W points set in [Device] are 5K points

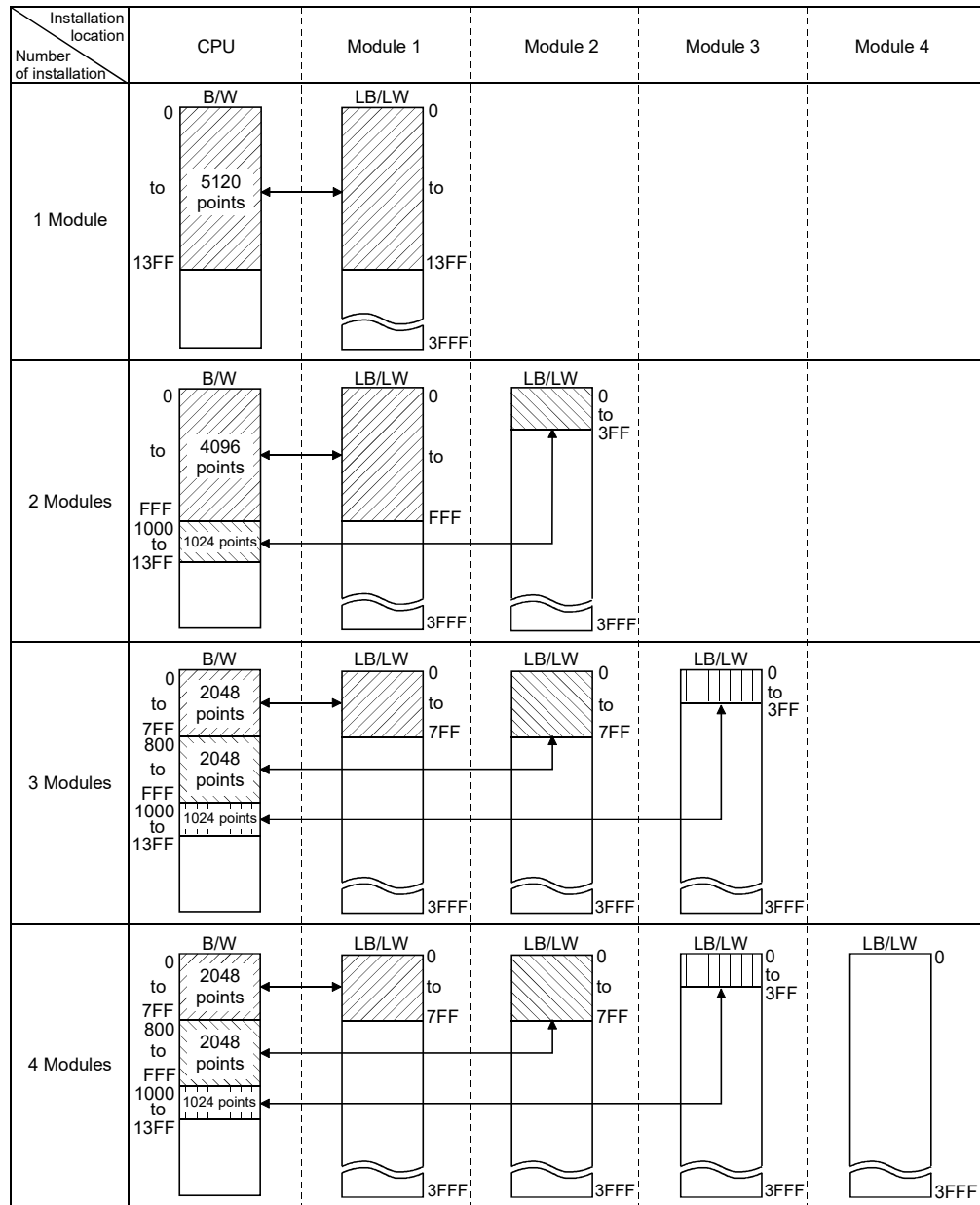

POINT
 LX/LY cannot be automatically set with the **Default** button.

(b) Manual setting by direct input

- 1) Select "Assignment method".
 Select "Points/Start" when entering link device points and start addresses.
 Select "Start/End" when entering start and end addresses of link devices.
- 2) Configure the settings for the link side and CPU side devices.

Example: When "Start/End" is selected

Assignment method		Transient transmission error history status							
<input type="radio"/> Points/Start <input checked="" type="radio"/> Start/End		<input checked="" type="radio"/> Overwrite <input type="radio"/> Hold							
	Link side					PLC side			
	Dev. name	Points	Start	End		Dev. name	Points	Start	End
Transfer SB	SB	512	0000	01FF	↔	SB	512	0000	01FF
Transfer SW	SW	512	0000	01FF	↔	SW	512	0000	01FF
Random cyclic	LB				↔				
Random cyclic	LW				↔				
Transfer1	LB	4096	0000	0FFF	↔	B	4096	0000	0FFF
Transfer2	LW	4096	0000	0FFF	↔	W	4096	0000	0FFF
Transfer3	LX	2048	1000	17FF	↔	X	2048	1000	17FF
Transfer4	LY	2048	1000	17FF	↔	Y	2048	1000	17FF

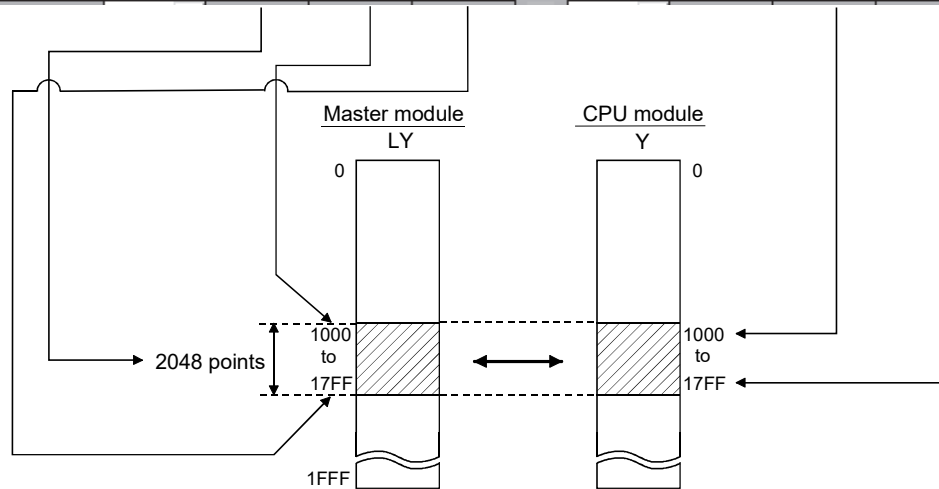

POINT
When setting the CPU side device range, check if: <ul style="list-style-type: none"> • The refresh range does not overlap with any other range (e.g. actual I/O). • The CPU side device range is within the range set in [Device] of [PLC parameter]. Device ranges can be checked by selecting [Tools] – [Check parameters] in GX Developer.

- (3) When no refresh parameters are set
 (High Performance model QCPU, Process CPU, and Redundant CPU)

Link devices are assigned as shown below.

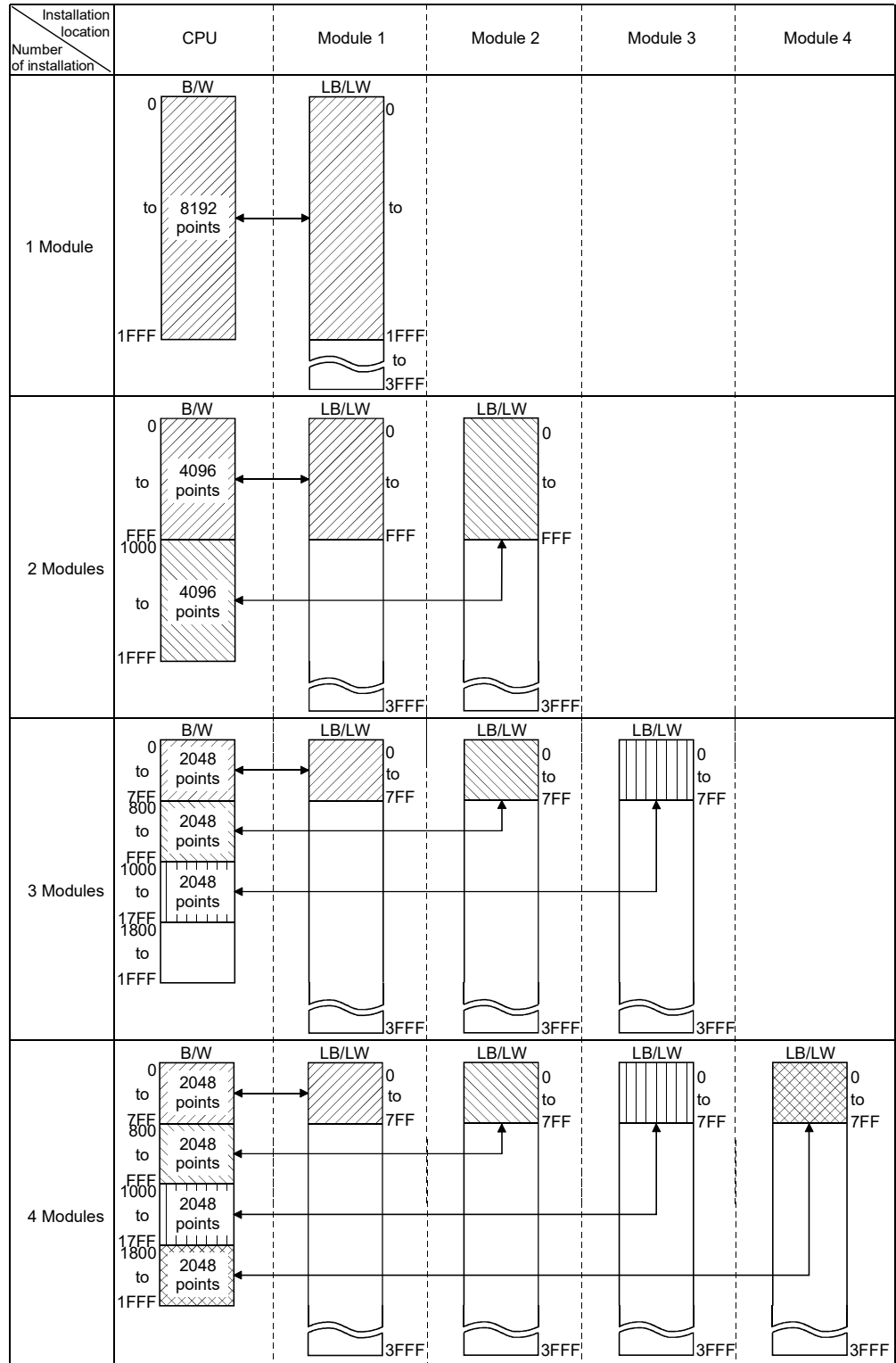

POINT

When B/W points less than the following are set in [Device] under [PLC parameter], set refresh parameters accordingly.

Or, increase the B/W points to the following value or more in [Device].

No. of modules	Device points in [Device]	
	B	W
1	8K points	8K points
2	8K points	8K points
3	6K points	6K points
4	8K points	8K points

(4) Setting example

The following shows an example of the refresh parameters settings:

[System configuration]

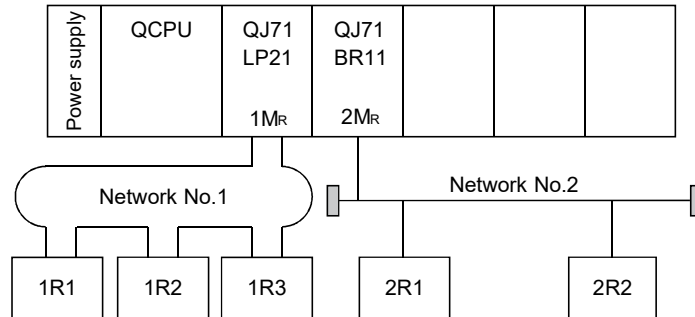

[Parameter assignments]

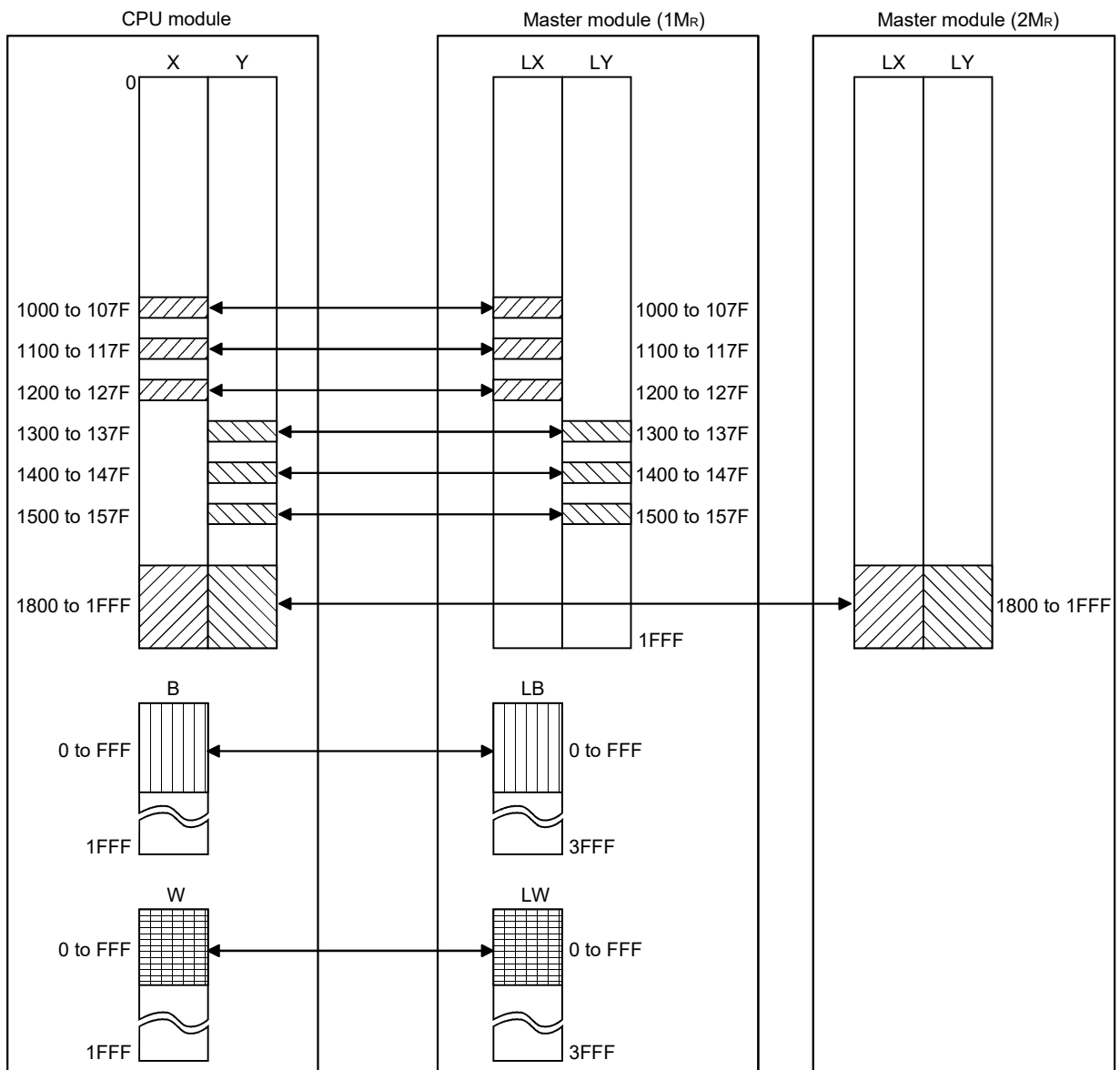

[Setting screen]

The following shows the settings of the refresh parameters for each module that are displayed on the screen.

Settings of module 1 (1MR)

	Link side					PLC side			
	Dev. name	Points	Start	End		Dev. name	Points	Start	End
Transfer SB	SB	512	0000	01FF	↔	SB	512	0000	01FF
Transfer SW	SW	512	0000	01FF	↔	SW	512	0000	01FF
Random cyclic	LB				↔				
Random cyclic	LW				↔				
Transfer1	LB	4096	0000	0FFF	↔	B	4096	0000	0FFF
Transfer2	LW	4096	0000	0FFF	↔	W	4096	0000	0FFF
Transfer3	LX	128	1000	107F	↔	X	128	1000	107F
Transfer4	LX	128	1100	117F	↔	X	128	1100	117F
Transfer5	LX	128	1200	127F	↔	X	128	1200	127F
Transfer6	LY	128	1300	137F	↔	Y	128	1300	137F
Transfer7	LY	128	1400	147F	↔	Y	128	1400	147F
Transfer8	LY	128	1500	157F	↔	Y	128	1500	157F

Settings of module 2 (2Mr) (transfer SB, transfer SW, transfers 1 and 2)

	Link side					PLC side			
	Dev. name	Points	Start	End		Dev. name	Points	Start	End
Transfer SB	SB	512	0000	01FF	↔	SB	512	0200	03FF
Transfer SW	SW	512	0000	01FF	↔	SW	512	0200	03FF
Random cyclic	LB				↔				
Random cyclic	LW				↔				
Transfer1	LX	2048	1800	1FFF	↔	X	2048	1800	1FFF
Transfer2	LY	2048	1800	1FFF	↔	Y	2048	1800	1FFF
Transfer3					↔				
Transfer4					↔				
Transfer5					↔				
Transfer6					↔				

5.1.6 Valid module during other station access

This parameter is used to specify any of the following modules to be relayed when a data communication request for which the network No. of the access target programmable controller station cannot be specified from the host (access from the serial communication module (A compatible 1C frame), Ethernet module (A compatible 1E frame), etc. to other stations) is issued.

- CC-Link IE Controller Network, CC-Link IE Field Network, MELSECNET/H, MELSECNET/10 module
- Ethernet module

This setting is not required when a data communication request for which the network No. can be specified, such as the serial communication module (QnA compatible 3C frame, QnA compatible 4C frame) or Ethernet module (QnA compatible 3E frame), is used. Leave it as the default (1) setting.

For details of the serial communication module or Ethernet module protocol, refer to the MELSEC-Q/L MELSEC Communication Protocol Reference Manual.

[Screen settings]

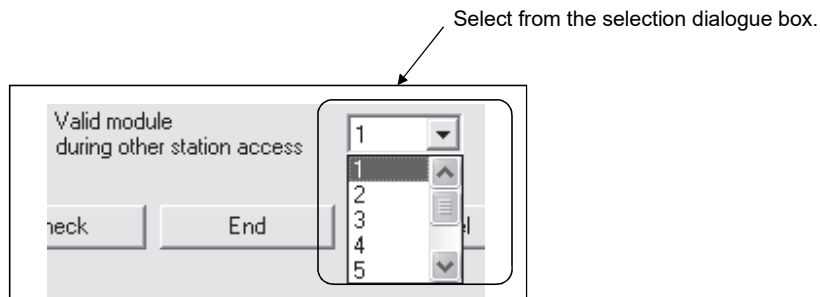

(Example)

In the example below, the personal computer connected to the serial communication module can communicate with the station on network No. 2 where the network module 3 is connected.

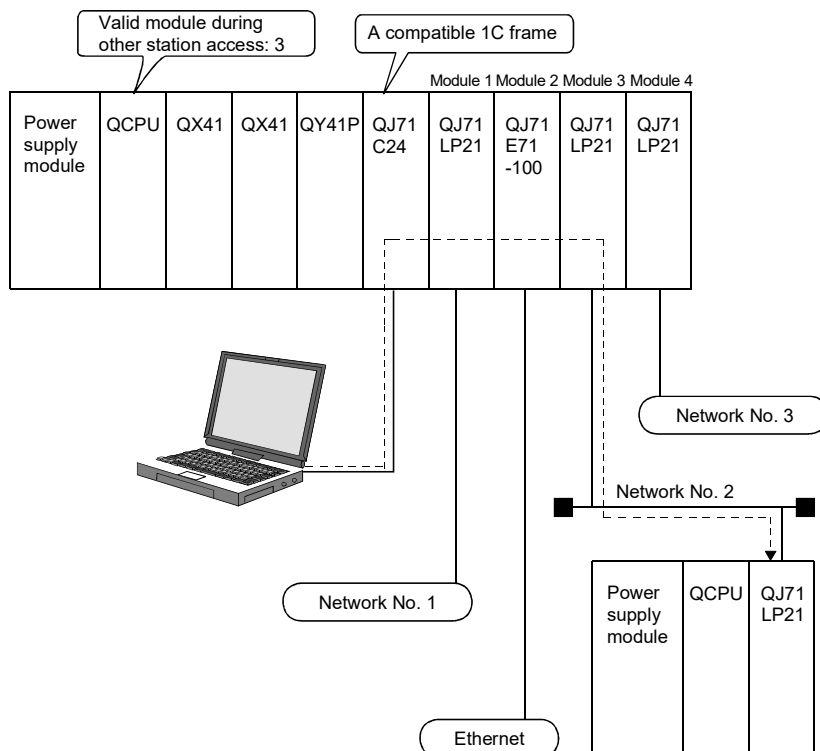

5.1.7 Redundant settings

For the multiplexed remote master station for redundant system, it is necessary to set the same mode as the mode applied to the multiplexed remote master station (system A) to the multiplexed remote sub-master station (system B).

Set the mode of system B in the redundant settings.

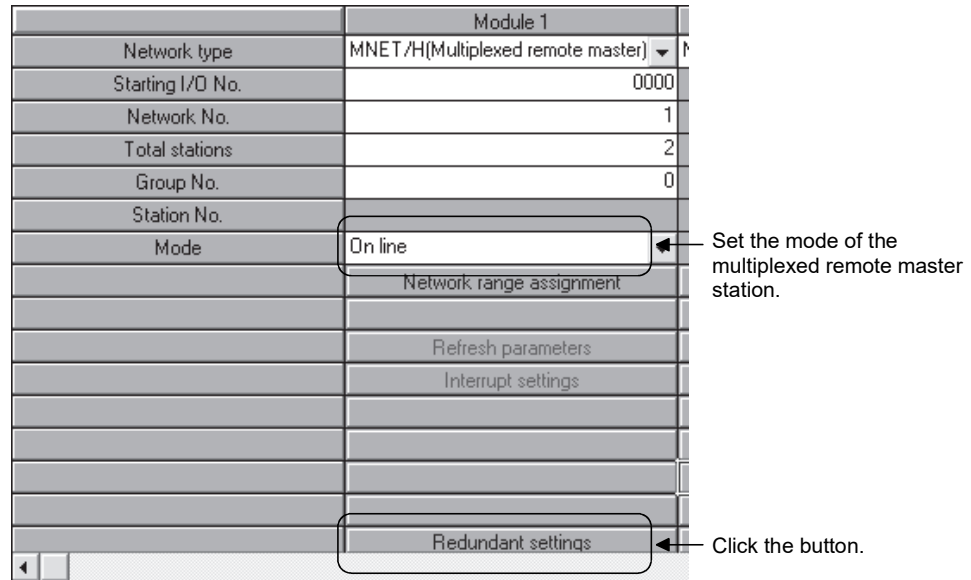

Set the mode of system B on the redundant setting screen.

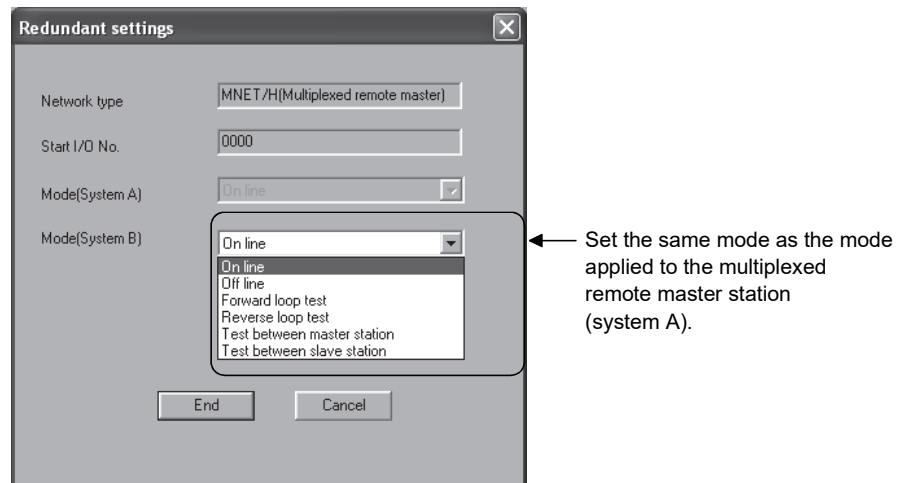

5.2 Remote I/O Station Parameter Settings

For remote I/O stations, set up the PLC parameters, network parameters, and remote password on the remote I/O module as needed.

POINT
After writing the parameters to the remote I/O module, reset it to enable the parameters that have been set. To reset the remote I/O module, use the reset switch on the module or power OFF and then ON the remote I/O station.

5.2.1 Remote I/O station possible parameter settings

The following parameters are set as needed on the remote I/O station and written to the remote I/O module.

If settings are not needed, the remote I/O station operates using the remote I/O module default settings so there is no need to write the parameters to the remote I/O module.

(1) PLC parameters

The remote I/O module can set the PLC parameters in the same manner as the CPU module. However, only the required items can be set as a remote I/O station.

Category	Item		Default	
PLC system	Module synchronization	Synchronizes intelligent module's pulse up	Selected	
	Points occupied by empty slot	Points occupied by empty slot	16 points	
PLC RAS	Error check	Carry out fuse blown check	Selected	
		Verify module	Selected	
	Operating mode when there is an error *1	Fuse blown	Stop	
		Module verify error	Stop	
Operational settings	Remote I/O switch setting	Remote I/O switch setting (For future expansion)	—	
	Assignment method	Points/Start	Start/End	
		Start/End		
	Forwarding parameter between devices	Device name	Blank	
		Points/Start		
		Start/End		
I/O assignment	I/O assignment	Type	Blank	
		Model name		
		Points		
		StartXY		
		Switch setting		Switches 1 to 5
	Detailed setting	Error time output mode		Clear
			H/W error time PLC operation mode *2	Stop
		I/O response time		10ms or 0.2ms
		Standard setting	Base model name	Blank
			Power model name	
Extension cable				
Slots				
Base mode	Auto			

*1: The operation mode of a remote I/O station under the error status can be set differently from the parameters of the remote master station (CPU module). When an error (fuse blowout or I/O verification error) occurs on the remote master station (CPU module) and remote I/O station, the data link and output of the remote I/O station are determined based on the combination of the parameter settings of remote I/O stations and remote master station (CPU module).

The table below lists the status of the data link and output of the remote I/O station based on the combination of parameter settings.

i) When an error occurs on the remote master station (CPU module)

		Setting of operation mode when an error has occurred on the remote master station (CPU module)	
		Stop	Continue
Setting of Operating mode when there is an error of remote I/O station	Stop	Data link: Stopped on all stations. Output: Conforms to the setting of output holding/clearing.	Data link: All stations are normal. Output: All stations output normally.
	Continue	Data link: Stopped on all stations. Output: Conforms to the setting of output holding/clearing.	Data link: All stations are normal. Output: All stations output normally.

ii) When an error occurs on a remote I/O station

		Setting of operation mode when an error has occurred on the remote master station (CPU module)	
		Stop	Continue
Setting of Operating mode when there is an error of remote I/O station	Stop	Data link: Stopped on all stations. Output: Conforms to the setting of output holding/clearing.	Data link: All stations are normal. Output: The error station conforms to the setting of output holding/clearing. The other stations output normally.
	Continue	Data link: Stopped on all stations. Output: Conforms to the setting of output holding/clearing	Data link: All stations are normal. Output: All stations output normally.

*2: When setting the H/W error time PLC operation mode, use the following remote I/O module and GX Developer:

- Remote I/O module: First five digits of serial No. is "10012" or later.
- GX Developer: GX Developer: Version 8.62Q or later.

For details about "PLC system", "PLC RAS" and "I/O assignment, refer to the user's manual (Function Explanation, Program Fundamentals) of the CPU module used.

(a) Operational settings

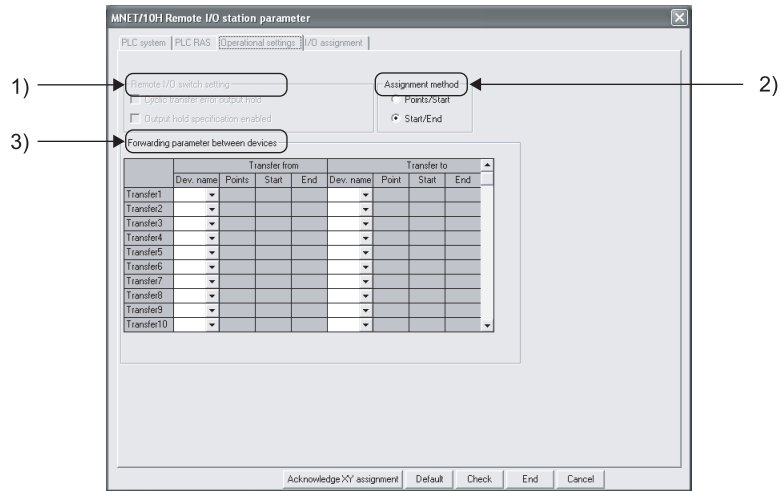

- 1) Remote I/O switch setting
For future expansion. Cannot be set at present time.
- 2) Assignment method
Select the assignment method for sending parameters between devices: "Points/Start" or "Start/End".
 - Assign the bit device (B, M) points in increments of 16 and the start/end addresses with the number in multiples of 16.
- 3) Forwarding parameter between devices
This sets the type of device and transfer range when data transfer is performed between internal remote I/O module devices. Up to 64 units can be set.
With the basic setting, when the intelligent function module buffer memory data is automatically refreshed to the remote I/O module data register D, that data is used if there data transfer to link register W. It is also used when link register data W data is transferred to data register D.

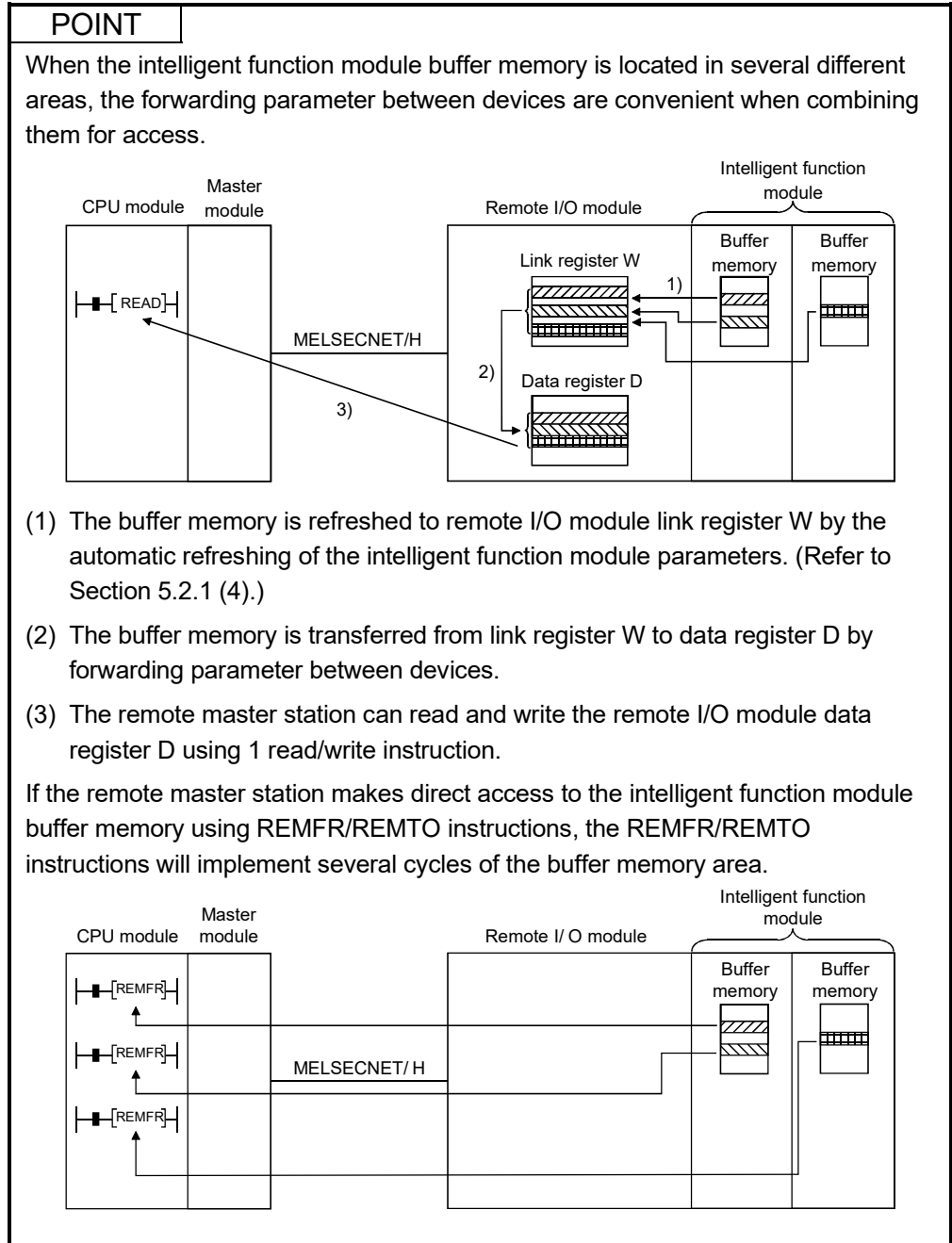

(2) Network parameters

The remote I/O module can set network parameters in the same way as the CPU module.

Major Items	Description
Ethernet settings	Sets the Ethernet network parameters.
CC-Link settings	Sets the CC-Link settings network parameters.

- (a) For details on Ethernet settings, refer to "Q Corresponding Ethernet Interface Module User's Manual (Basic) (SH-080009).
- (b) For details on CC-Link, refer to : "MELSEC-Q CC-Link System Master/Local Module User's Manual" (SH-080394E).

(3) Remote password

For remote I/O modules, a remote password similar to that applied to QCPU can be set.

Major Items	Description
Password settings	Set a remote password.
Password active module settings	Set the Ethernet module and serial communication module for making the password setting effective.

For the details of remote password, refer to Section 7.12.

(4) Intelligent function module parameters

The parameters of a connected intelligent function module and the auto refresh setting can be set in remote I/O modules.

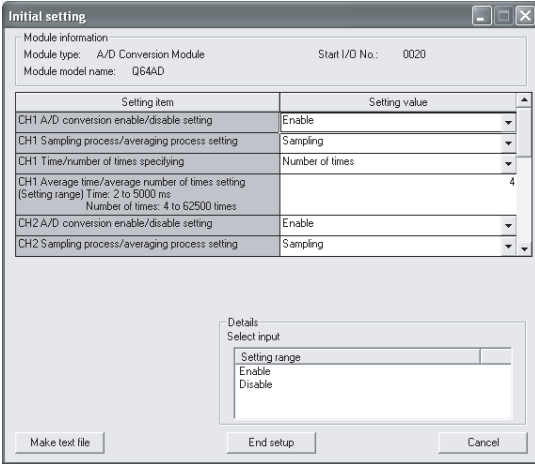
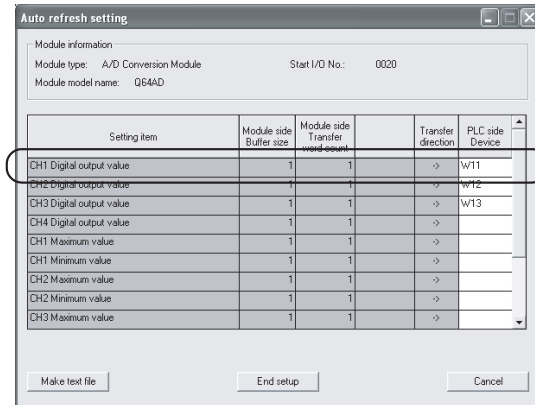
Major Items	Description
<p>Initial setting</p>	<p>Set the parameters of an intelligent function module. Up to 512 items can be set for the initial setting. The number of items to set varies depending on the intelligent function module used.</p> <p>[Example] Q64AD</p>  <p>The number of the initial setting items for a Q64AD is two. Add this number to the number of the setting items for other intelligent function modules.</p>
<p>Auto refresh setting</p>	<p>Set the devices for auto refresh between a remote I/O module and an intelligent function module. The devices M, B, D, and W can be used. Up to 256 items can be set for the auto refresh setting. Count the setting items as below.</p>  <p>One line is counted as one setting item. A blank column is not counted. Add all the setting items in this window to the number of the initial setting items for other intelligent function modules.</p>

- (a) When the number of setting items has exceeded the maximum number Remote I/O modules detect the "SP.PARA ERROR (3301)" error. To auto refresh the excessive items, use the REMFR/REMTO instruction to read/write data from/to the intelligent function module.

REMARKS

- Whether to set the initial setting and auto refresh setting varies depending on the intelligent function module used. Refer to the user's manual for the intelligent function module used.
- For the number of the initial setting items that can be set, refer to the user's manual for the intelligent function module used.

6 PROGRAMMING

When diverting the program example introduced in this chapter to the actual system, fully check that there are no problems in the controllability of the system.

6.1 Programming Precautions

This section explains the precautions in creating programs using data on the network.

6.1.1 Interlock related signals

A list of the interlock signal devices used in the sequence programs is provided below. Refer to Appendix 2, "List of the Link Special Relays (SB)" and Appendix 3, "List of the Link Special Registers (SW)" for other explanations, such as the operation status and setting status of the host and other stations.

When multiple network modules are installed, the interlock signal devices are refreshed to the devices on the PLC side at 512 points (0H to 1FFH) intervals according to the default settings as listed below.

POINT

The Q series uses the link special relays (SB) and the link special registers (SW) in the entire intelligent function module. Therefore, do not use the same SB and SW more than once in a program.

Assignment of the link special relay (SB) and the link special register (SW) when multiple modules are installed

Device \ Mounting position	1st module	2nd module	3rd module	4th module
SB	0H to 1FFH	200H to 3FFH	400H to 5FFH	600H to 7FFH
SW	0H to 1FFH	200H to 3FFH	400H to 5FFH	600H to 7FFH

List of Interlock Devices

No.	Name	Description	Use permitted/prohibited								
			Control station		Normal station		Remote master station		Remote I/O station		
			Optical	Coaxial	Optical	Coaxial	Optical	Coaxial	Optical	Coaxial	
SB0020 (32)	Module status	Indicates the communication status between the network module and the CPU module. Off: Normal On: Abnormal	○	○	○	○	○	○	○	×	×
SB0044 (68)	Station setting (host)	When PLC to PLC network Indicates the station type set with the parameter of the host's network module. Off: Normal station On: Control station	○	○	○	○	×	×	×	×	×
		When remote I/O network Indicates the station type set with the parameter of the host's network module. Off: Remote I/O station or multiplexed remote sub-master station On: Remote master station or multiplexed remote master station	×	×	×	×	○	○	○	○	○
SB0047 (71)	Baton pass status (host)	Indicates the host's baton pass status (transient transmission enabled). Off: Normal On: Abnormal When an error is identified, the cause of the error can be checked in Baton pass status (host) (SW0047) and Cause of baton pass interruption (SW0048).	○	○	○	○	○	○	○	○	○
* 1 SB0048 (72)	Control station status (host)	When PLC to PLC network Indicates the host's status. Off: Normal station On: Control station (SB0044 is on) Sub-control station (SB0044 is off)	○	○	○	○	×	×	×	×	×
	Remote master station status (host)	When remote I/O network Indicate the host status Off: Remote I/O station On: SB0044=On Remote master station or multiplexed remote master station SB0044=Off Remote I/O station or multiplexed remote sub-master station	×	×	×	×	○	○	○	○	○
SB0049 (73)	Host data link status	Indicates the host's data link operation status. Off: Normal On: Abnormal When an error is identified, the cause of the error can be checked in Cause of data link stop (SW0049).	○	○	○	○	○	○	○	○	○
* 1 SB0070 (112)	Baton pass status of each station	Indicates the baton pass status of each station. (Not applicable to reserved stations and the station with the maximum station number or higher) Off: All stations normal On: Faulty station exists When any faulty station exists, each station status can be checked in Baton pass status of each station (SW0070 to SW0073). Depending on the timing of the link refresh, Baton pass status of each station (SW0070 to SW0073) and the update may be offset by one sequence scan.	○	○	○	○	○	○	○	○	○
* 1 SB0074 (116)	Cyclic transmission status of each station	Indicates the cyclic transmission status of each station. (Not applicable to reserved stations and the station with the maximum station number or higher) Off: All stations are executing data linking On: Stations that are not executing data linking exist When any non-executing station exists, each station status can be checked in Cyclic transmission status of each station (SW0074 to SW0077). Depending on the timing of the link refresh, Cyclic transmission status of each station (SW0074 to SW0077) and the update may be offset by one sequence scan.	○	○	○	○	○	○	○	○	○

[Availability column] Optical: optical loop, Coaxial: coaxial bus
○: Available, ×: Not available

* 1: Valid only when SB0047 is off. When it turns on (error), the last data are retained.



No.	Name	Description	Use permitted/prohibited																																																														
			Control station		Normal station		Remote master station		Remote I/O station																																																								
			Optical	Coaxial	Optical	Coaxial	Optical	Coaxial	Optical	Coaxial																																																							
* 1 SW0070 (112)/ SW0071 (113)/ SW0072 (114)/ SW0073 (115)	Baton pass status of each station	<p>Stores the baton pass status of each station (including the host).</p> <p><Online> 0: Normal (including the stations with the maximum station number and smaller numbers as well as reserved stations) 1: Abnormal</p> <p><Offline test> 0: Normal 1: Abnormal (including the stations with the maximum station number and smaller numbers as well as reserved stations)</p> <table border="1"> <thead> <tr> <th></th> <th>b15</th> <th>b14</th> <th>b13</th> <th>b12</th> <th>to</th> <th>b4</th> <th>b3</th> <th>b2</th> <th>b1</th> <th>b0</th> </tr> </thead> <tbody> <tr> <td>SW0070</td> <td>16</td> <td>15</td> <td>14</td> <td>13</td> <td>to</td> <td>5</td> <td>4</td> <td>3</td> <td>2</td> <td>1</td> </tr> <tr> <td>SW0071</td> <td>32</td> <td>31</td> <td>30</td> <td>29</td> <td>to</td> <td>21</td> <td>20</td> <td>19</td> <td>18</td> <td>17</td> </tr> <tr> <td>SW0072</td> <td>48</td> <td>47</td> <td>46</td> <td>45</td> <td>to</td> <td>37</td> <td>36</td> <td>35</td> <td>34</td> <td>33</td> </tr> <tr> <td>SW0073</td> <td>64</td> <td>63</td> <td>62</td> <td>61</td> <td>to</td> <td>53</td> <td>52</td> <td>51</td> <td>50</td> <td>49</td> </tr> </tbody> </table> <p>Numbers 1 to 64 in the above table indicate the station numbers.</p>		b15	b14	b13	b12	to	b4	b3	b2	b1	b0	SW0070	16	15	14	13	to	5	4	3	2	1	SW0071	32	31	30	29	to	21	20	19	18	17	SW0072	48	47	46	45	to	37	36	35	34	33	SW0073	64	63	62	61	to	53	52	51	50	49	○	○	○	○	○	○	○	○
	b15	b14	b13	b12	to	b4	b3	b2	b1	b0																																																							
SW0070	16	15	14	13	to	5	4	3	2	1																																																							
SW0071	32	31	30	29	to	21	20	19	18	17																																																							
SW0072	48	47	46	45	to	37	36	35	34	33																																																							
SW0073	64	63	62	61	to	53	52	51	50	49																																																							
* 1 SW0074 (116)/ SW0075 (117)/ W0076 (118)/ SW0077 (119)	Cyclic transmission status of each station	<p>Stores the cyclic transmission status of each station (including the host).</p> <p>0: Executing cyclic transmission (including the station with the maximum station number and smaller number as well as reserved stations) 1: Cyclic transmission not executed</p> <table border="1"> <thead> <tr> <th></th> <th>b15</th> <th>b14</th> <th>b13</th> <th>b12</th> <th>to</th> <th>b4</th> <th>b3</th> <th>b2</th> <th>b1</th> <th>b0</th> </tr> </thead> <tbody> <tr> <td>SW0074</td> <td>16</td> <td>15</td> <td>14</td> <td>13</td> <td>to</td> <td>5</td> <td>4</td> <td>3</td> <td>2</td> <td>1</td> </tr> <tr> <td>SW0075</td> <td>32</td> <td>31</td> <td>30</td> <td>29</td> <td>to</td> <td>21</td> <td>20</td> <td>19</td> <td>18</td> <td>17</td> </tr> <tr> <td>SW0076</td> <td>48</td> <td>47</td> <td>46</td> <td>45</td> <td>to</td> <td>37</td> <td>36</td> <td>35</td> <td>34</td> <td>33</td> </tr> <tr> <td>SW0077</td> <td>64</td> <td>63</td> <td>62</td> <td>61</td> <td>to</td> <td>53</td> <td>52</td> <td>51</td> <td>50</td> <td>49</td> </tr> </tbody> </table> <p>Numbers 1 to 64 in the above table indicate the station numbers.</p> <p>If a CPU module installed together with QJ71LP21S-25 is turned OFF, detection of a data link error may take more time than usual. For immediate detection of a data link error, program an interlock using the link relay (LB) in each station's send range. For details, refer to the Q corresponding MELSECNET/H Network System Reference Manual (PLC to PLC network).</p>		b15	b14	b13	b12	to	b4	b3	b2	b1	b0	SW0074	16	15	14	13	to	5	4	3	2	1	SW0075	32	31	30	29	to	21	20	19	18	17	SW0076	48	47	46	45	to	37	36	35	34	33	SW0077	64	63	62	61	to	53	52	51	50	49	○	○	○	○	○	○	○	○
	b15	b14	b13	b12	to	b4	b3	b2	b1	b0																																																							
SW0074	16	15	14	13	to	5	4	3	2	1																																																							
SW0075	32	31	30	29	to	21	20	19	18	17																																																							
SW0076	48	47	46	45	to	37	36	35	34	33																																																							
SW0077	64	63	62	61	to	53	52	51	50	49																																																							

[Availability column] Optical: optical loop, Coaxial: coaxial bus
○: Available, ×: Not available

* 1: Valid only when SB0047 is off. When it turns on (error), the last data are retained.

6.1.2 Program example

Interlocks should be applied to the programs according to the link status of the host and other stations.

The following example shows an interlock in the communication program that uses the link status of the host (SB0047, SB0049) and the link status of station number 2 (bit 1 of SW0070 and bit 1 of SW0074).

(Example)

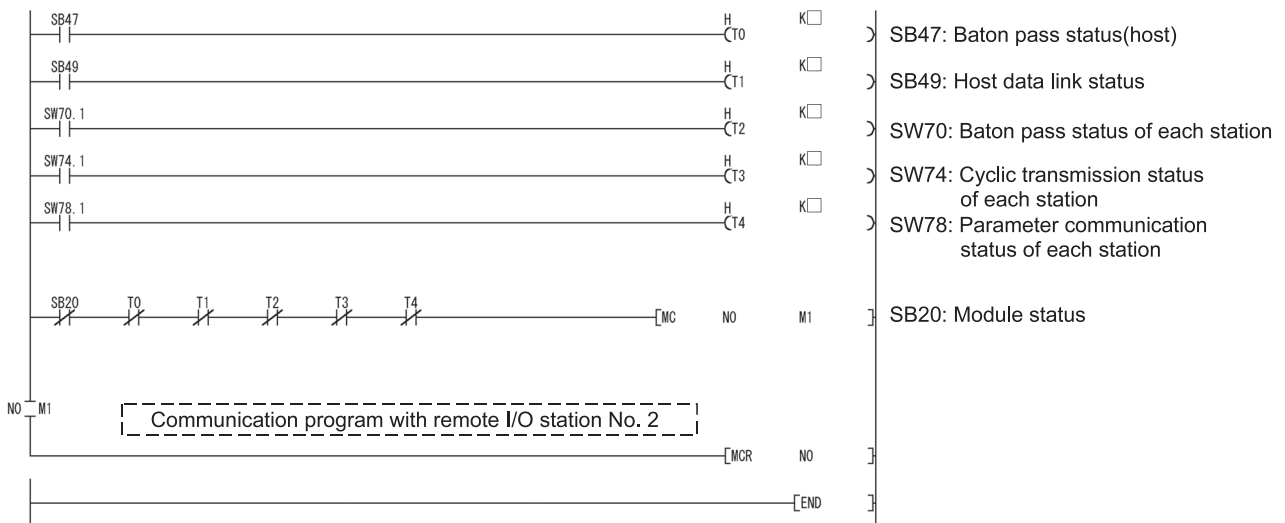

Set the values listed below for timer constant K □.

Baton pass status (T0, T2)	(Sequence scan time × 4) or more
Cyclic transmission status Parameter communication status (T1, T3, T4)	(Sequence scan time × 3) or more

Reason: This is to prevent occasional errors due to cable conditions or electrical noise from stopping control.

Also, the multipliers of 4 and 3 should only be considered as a guideline.

If the initial settings for the buffer memory of the intelligent function module on a remote I/O station are set by a link dedicated instruction (REMTO instruction), write the program so that when only that remote I/O module is reset (by turning the remote I/O module power supply off or by using the remote I/O module reset switch), the remote master station will detect that condition and will once again execute the initial settings in the intelligent function module.

This program is for resetting the intelligent function module on the remote I/O station whenever the remote I/O station is reset.

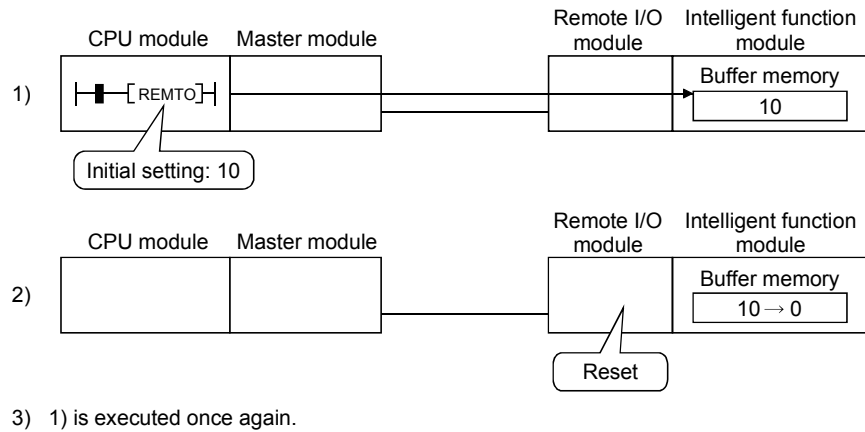

POINT

When the intelligent function module parameters (initial settings) are written to the remote I/O station, the intelligent function module initial settings are automatically set, even if the remote I/O station is reset.

The following cases may occur when performing the initial settings to the intelligent function module.

- (a) Analog-digital conversion module Q64AD A/D conversion permit/prohibit setting.
- (b) Digital-analog conversion module Q62DA D/A conversion permit/prohibit.

The operating status of the remote I/O station can be confirmed by the special register for the links for each station baton pass status (SW0070 to SW0073).

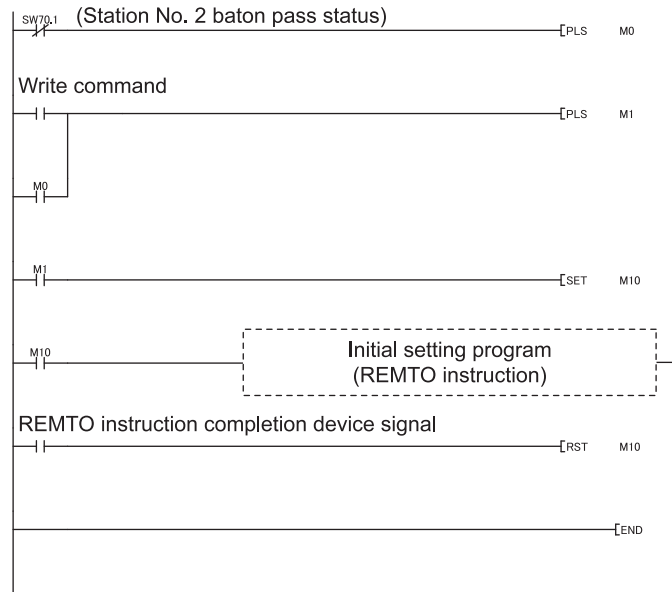

6.2 Cyclic Transmission

Depending on the timing of the link refresh, 32-bit (2-word) type link data may be broken up into new and old data in units of 16 bits (one word).

- Current values of analog-digital converter module
- Current values of positioning module, command speed.

The remote I/O network provides the following functions for making handling of the link data easy.

- 32-bit data assurance : Section 6.2.1
- Block data assurance per station of cyclic: Section 6.2.2 data

6.2.1 32-bit data assurance

32-bit data precision is guaranteed automatically by setting parameters so that the following conditions 1) to 4) are satisfied.

If conditions 1) to 4) are not satisfied, a warning for 32-bit data separation is displayed during setting with GX Developer.

- 1) The start device number of LB is a multiple of 20H.
- 2) The number of assigned LB points per station is a multiple of 20H.
- 3) The start device number of LW is a multiple of 2.
- 4) The number of assigned LW points per station is a multiple of 2.

Parameter settings for network range assignments

StationNo.	M station -> R station			M station <- R station			M station -> R station			M station <- R station		
	B			B			W			W		
	Points	Start	End	Points	Start	End	Points	Start	End	Points	Start	End
1	32	0000	001F	32	0100	011F	16	0000	000F	16	0400	040F
2	32	0020	003F	32	0120	013F	16	0100	010F	16	0500	050F
3	32	0040	005F	32	0140	015F	16	0200	020F	16	0600	060F
4	32	0060	007F	32	0160	017F	16	0300	030F	16	0700	070F

Refreshing link devices that satisfy the above conditions 1) to 4) guarantees consistency of 32-bit data.

POINT	To guarantee data larger than 32 bits (2 words), use the station unit block assurance in Section 6.2.2.
--------------	---

6.2.2 Block data assurance per station of cyclic data

Since link refresh is performed by handshaking between the CPU and network modules, cyclic data integrity is assured in units of stations.

The Block data assurance per station of cyclic data is a function that prevents link data consisting of two words (32 bits), such as a current value of a positioning module, from being divided into new and old data in units of one word (16 bits).

As shown below, set the send and receive parameters as needed.

These settings can be made using the common parameters (supplementary settings) only for the remote master station.

- Default: Disabled

Network range assignments Supplementary settings

<input type="checkbox"/>	Block send data assurance per station
<input type="checkbox"/>	Block receive data assurance per station

By selecting both [Block send data assurance per station] and [Block receive data assurance per station], an interlock for the link data between the stations to be set becomes unnecessary.

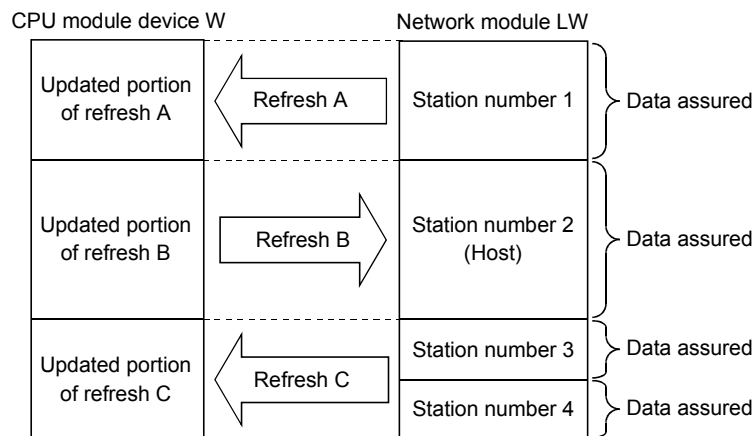

<Precautions>

- (1) In order to enable the block data assurance per station, it is necessary to set the refresh parameters. (Refer to Section 5.1.5.)
- (2) It is not necessary to set the block data assurance per station of cyclic data for remote I/O stations.

POINT

For the transmission delay time calculation for the case where the Block send/receive data assurance per station is set enabled, refer to Section 3.3.2 (1) (a) and (2) (a) POINT.

6.3 Communications with I/O Modules

This section describes the setting and programming that are required for a CPU to communicate with I/O modules on a remote I/O station by cyclic transmission.

(1) System configuration example

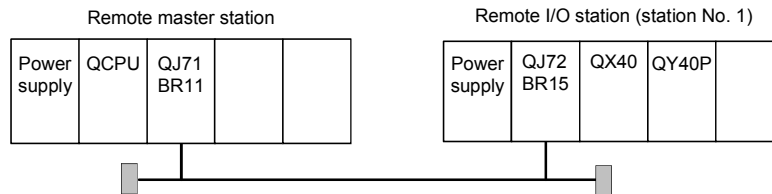

(2) Program conditions

The following processing is performed in the program.

- An input from X0 of the remote I/O station turns ON M1000.
- When M2000 is turned ON, a signal is output to Y0 of the remote I/O station.

(a) Devices used by the user

- Input flag from X0 of remote I/O station.....M1000
- Output flag to Y10 of remote I/O stationM2000

(3) Parameter setting example

(a) Setting for the CPU module of the remote master station

Set network parameters in GX Developer.

- Network type : MNET/H (Remote master)
- Starting I/O No. : 0000H
- Network No. : 1
- Total stations : 1
- Mode : Online
- Network range assignment:

StationNo.	M station → R station						M station ← R station					
	Y			Y			X			X		
	Points	Start	End	Points	Start	End	Points	Start	End	Points	Start	End
1	256	1000	10FF	256	0000	00FF	256	1000	10FF	256	0000	00FF

- Refresh parameters:

	Link side						PLC side				
	Dev. name	Points	Start	End	Dev. name		Points	Start	End		
Transfer SB	SB	512	0000	01FF	↔	SB	512	0000	01FF		
Transfer S'w	S'w	512	0000	01FF	↔	S'w	512	0000	01FF		
Random cyclic	LB				↔						
Random cyclic	LW				↔						
Transfer1	LX	512	1000	11FF	↔	X	512	1000	11FF		
Transfer2	LY	512	1000	11FF	↔	Y	512	1000	11FF		

(b) Setting for the remote I/O module

Use the default settings. (Refer to Section 5.2.1.)

(4) Program example

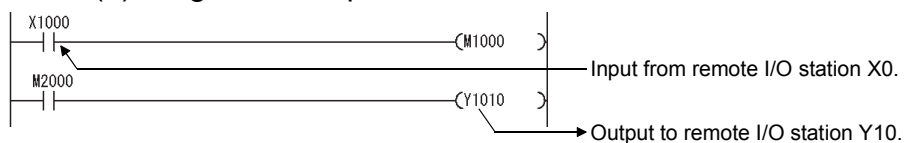

6.4 Communications with Intelligent Function Modules

This section describes the setting and programming that are required for a CPU module to communicate with intelligent function modules on a remote I/O station by cyclic transmission.

(1) System configuration example

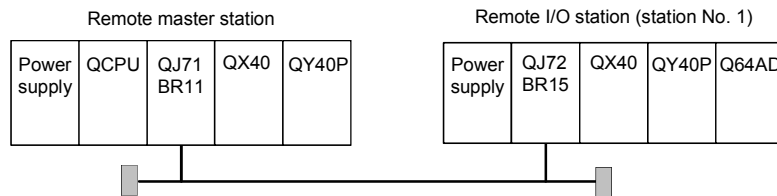

Complete the following intelligent function module switch settings on the remote I/O module in advance.

- Switch 1 0430_H (CH1: 4 to 20mA, CH2: 0 to 5V, CH3: -10 to 10V)
- Switch 2 Empty
- Switch 3 Empty
- Switch 4 0000_H (Normal mode (A/D conversion processing))
- Switch 5 0000_H (0: Fixed)

(2) Program conditions

In this program, the digital output values that have been A/D converted using CH1 to CH3 of the Q64AD are read by the CPU of the remote master station. CH1 performs sampling processing, CH2 performs averaging processing every 50 times, and CH3 performs averaging processing every 1000ms. An error code appears in BCD format if a write error occurs.

(a) Initial settings

- A/D conversion enable channel CH1 to CH3
- Count-based averaging processing channel Average count setting of CH2: 50 times
- Channel performing averaging processing using time ... Average time setting of CH3: 1000ms

(b) Devices used by the user

- Initial setting request signalX20
- Digital output value read command input signalX21
- Error reset signalX23
- Error code display (BCD 3 digits)Y30 to Y3B
- A/D conversion completed flagD10
- CH1 digital output valueD11 (W11)
- CH2 digital output valueD12 (W12)
- CH3 digital output valueD13 (W13)
- Error codeD14 (W14)

6.4.1 Program example when using GX Configurator

(1) Setting for the CPU module on the remote master station

Set network parameters in GX Developer.

(a) Setting network parameters

- Network type : MNET/H (Remote master)
- Starting I/O No. : 0000H
- Network No. : 1
- Total stations : 1
- Mode : Online
- Network range assignment:

StationNo.	M station -> R station						M station <- R station					
	Y			Y			X			X		
	Points	Start	End	Points	Start	End	Points	Start	End	Points	Start	End
1	256	1000	10FF	256	0000	00FF	256	1000	10FF	256	0000	00FF

StationNo.	M station > R station			M station <- R station			M station > R station			M station <- R station		
	B			B			W			W		
	Points	Start	End	Points	Start	End	Points	Start	End	Points	Start	End
1							160	0100	019F	160	0000	009F

• Refresh parameters:

	Link side						PLC side				
	Dev. name	Points	Start	End	Dev. name		Points	Start	End		
Transfer SB	SB	512	0000	01FF	↔	SB	512	0000	01FF		
Transfer SW	SW	512	0000	01FF	↔	SW	512	0000	01FF		
Random cyclic	LB				↔						
Random cyclic	LW				↔						
Transfer1	LB	8192	0000	1FFF	↔	B	8192	0000	1FFF		
Transfer2	LW	8192	0000	1FFF	↔	W	8192	0000	1FFF		
Transfer3	LX	512	1000	11FF	↔	X	512	1000	11FF		
Transfer4	LY	512	1000	11FF	↔	Y	512	1000	11FF		
Transfer5					↔						

(2) Setting for the remote I/O module

In GX Developer, set the intelligent function module switches. (Refer to Section 6.4 (1).)

Also, set intelligent function module parameters in GX Configurator. Configure the following settings.

- Start I/O No. : 20
- Module type : A/D Conversion Module
- Module model name : Q64AD

(a) Initial setting *1

- CH1, CH2, CH3 A/D conversion enable/disable setting..... "Enable"
- CH1 Sampling process/averaging process setting "Sampling"
- CH2 Sampling process/averaging process setting "Averaging"
- CH2 Time/number of times specifying "50"
- CH3 Sampling process/averaging process setting "Averaging"
- CH3 Average time/average number of times setting "1000"

*1: Note that the number of intelligent function module parameters that may be set for initial setting is limited.

The number of parameters that may be set for initial setting is as follows.

Sum total of the numbers of parameters within the setting ranges of all intelligent function modules ≤ 512

If the number of parameters set exceeds the limited number, the remote I/O module detects the "SP. PARA ERROR (3301)" error.

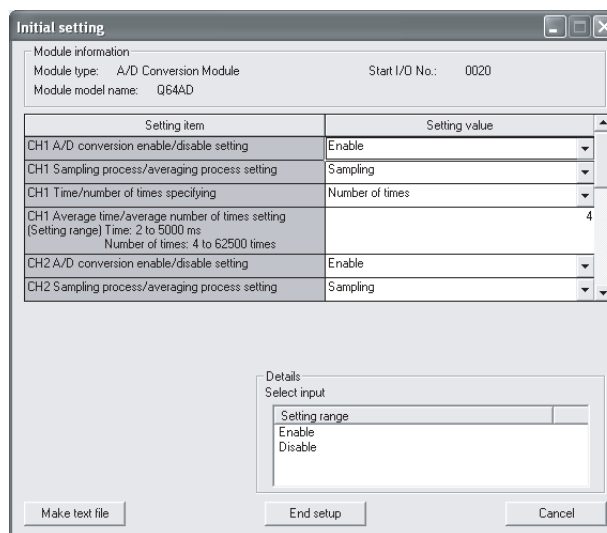

The number of the initial setting items for a Q64AD is two. Add this number to the number of the setting items for other intelligent function modules.

POINT
<p>If the remote I/O module has detected the error, read/write the data of the intelligent function modules using the REMFR/REMTO instruction.</p> <p>The number of parameters for initial setting is fixed for each intelligent function module.</p> <p>To confirm the numbers of parameters for initial setting, refer to the user's manuals of the corresponding intelligent function modules.</p>

(b) Auto refresh setting*1

CH1 Digital output value "W11"
 CH2 Digital output value "W12"
 CH3 Digital output value "W13"
 Error code "W14"

*1: Note that the number of intelligent function module parameters that may be set for automatic refresh setting is limited.
 The number of parameters that may be set for automatic refresh setting is as follows.

Sum total of the numbers of parameters within the setting ranges of all intelligent function modules ≤ 256

If the number of parameters set exceeds the limited number, the remote I/O module detects the "SP. PARA ERROR (3301)" error.

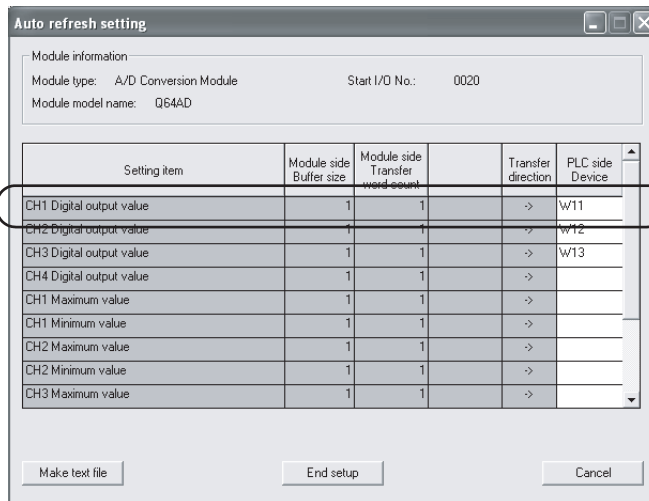

One line is counted as one setting item. A blank column is not counted. Add all the setting items in this window to the number of the initial setting items for other intelligent function modules.

POINT
<p>(1) If automatic refresh settings are performed by the intelligent function module parameters in the remote I/O module, do not use device X,Y in the PLC-side device. If these are incorrectly used, the network will not operated properly. In the same manner, do not use device X,Y in the CC-Link refresh settings with the remote I/O module network parameters.</p> <p>(2) If the error has been detected, read/write the data of the intelligent function modules using the REMFR/REMTO instruction. The number of parameters for automatic refresh setting is preset to each intelligent function module. To confirm the numbers of parameters for automatic refresh setting, refer to the user's manuals of the corresponding intelligent function modules.</p>

REMARKS

Refer to the manual for the intelligent function module for details about the method for setting the intelligent parameters.

(3) Program example

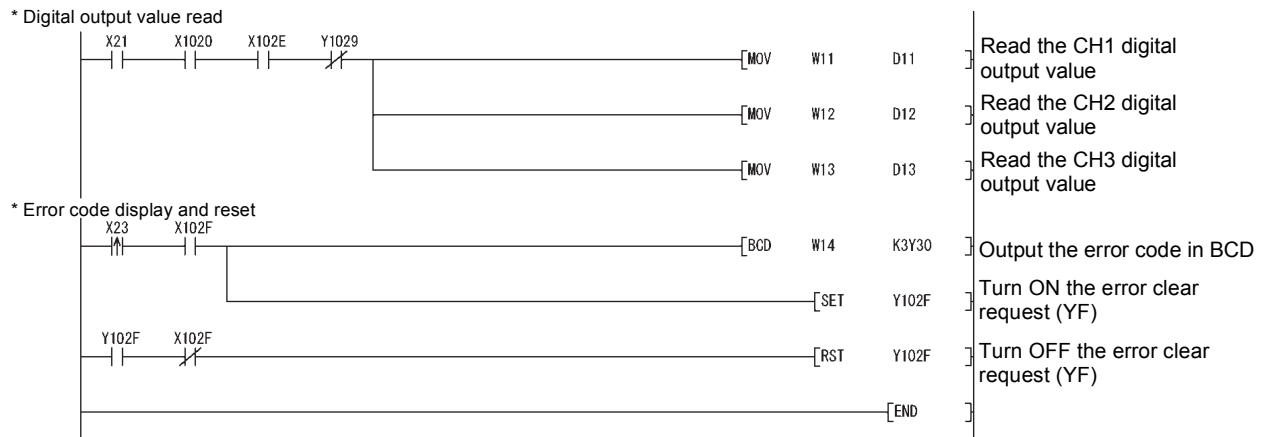

6.4.2 Program example when not using GX Configurator

POINT

Execution of the REMFR/REMTO instruction needs several scans. Therefore, the execution result of the REMFR/REMTO instruction cannot be synchronized with operations of the I/O signals. When reading a digital output value on a Q64AD after changing the operating condition during operation, be sure to read the A/D conversion completed flag (buffer memory address 10) at the same time. Also, for the case of changing the operating condition, insert an interlock to prevent the execution of the REMFR instruction.

(1) Setting for the CPU module on the remote master station

- Network type : MNET/H (Remote master)
- Starting I/O No. : 0000H
- Network No. : 1
- Total stations : 1
- Mode : Online
- Network range assignment:

StationNo.	M station -> R station						M station <- R station					
	Y			Y			X			X		
	Points	Start	End	Points	Start	End	Points	Start	End	Points	Start	End
1	256	1000	10FF	256	0000	00FF	256	1000	10FF	256	0000	00FF

- Refresh parameters:

	Link side						PLC side				
	Dev. name	Points	Start	End	Dev. name		Points	Start	End		
Transfer SB	SB	512	0000	01FF	↔	SB	512	0000	01FF		
Transfer S'w	S'w	512	0000	01FF	↔	S'w	512	0000	01FF		
Random cyclic	LB				↔						
Random cyclic	LW				↔						
Transfer1	LB	8192	0000	1FFF	↔	B	8192	0000	1FFF		
Transfer2	LW	8192	0000	1FFF	↔	w	8192	0000	1FFF		
Transfer3	LX	512	1000	11FF	↔	X	512	1000	11FF		
Transfer4	LY	512	1000	11FF	↔	Y	512	1000	11FF		
Transfer5					↔						

(2) Setting for the remote I/O module

In GX Developer, set the intelligent function module switches. (Refer to Section 6.4 (1).)

(3) Program example

* Remote I/O station operating status checking

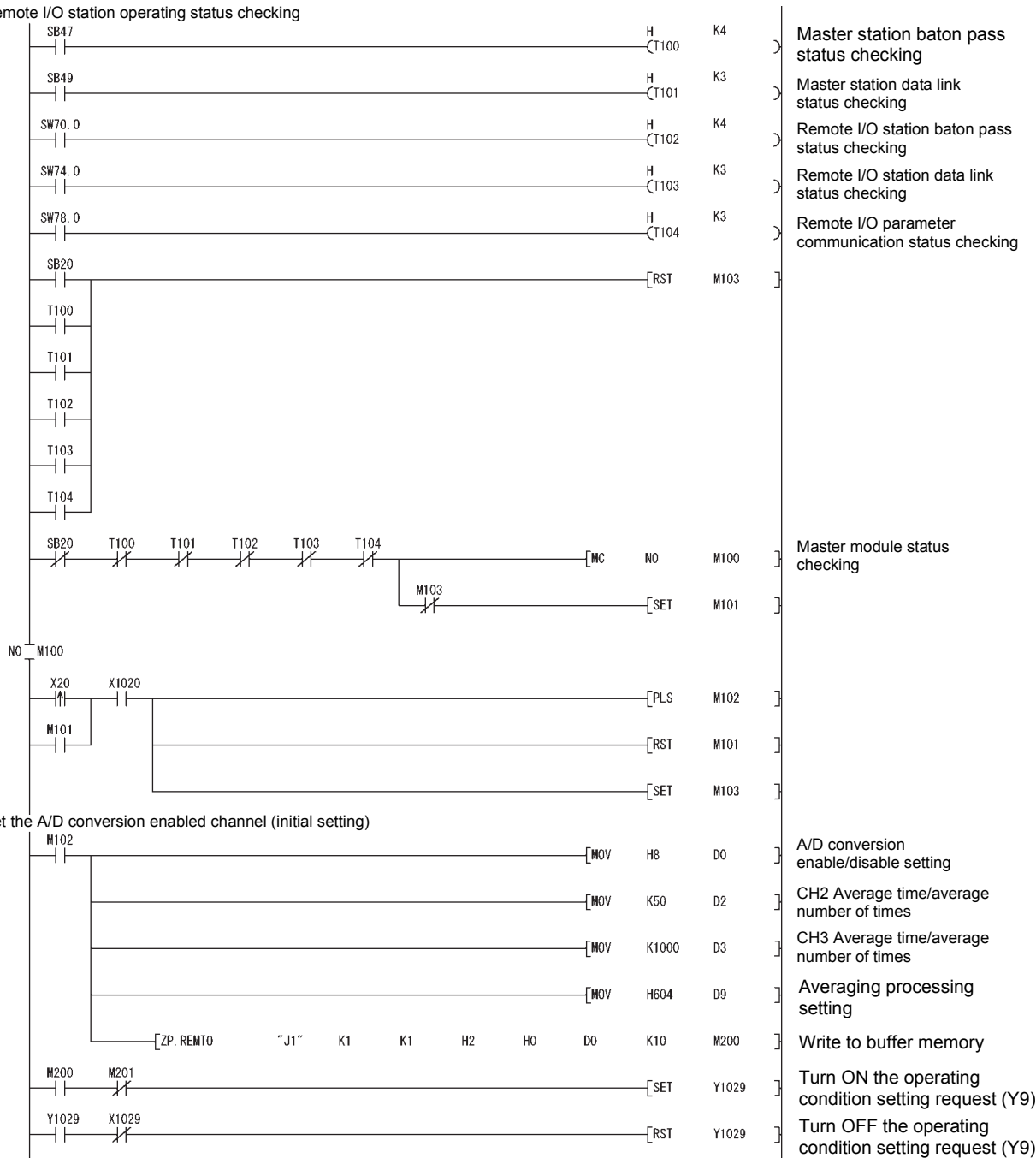

* Digital output value read processing

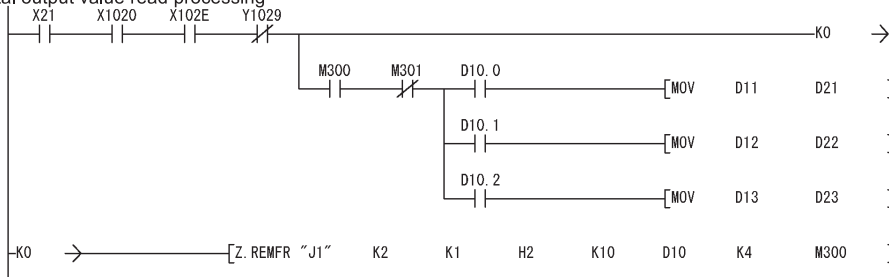

→ Concurrently reads the A/D conversion completed flag and CH1-to-CH3 digital output values.

] Read the CH1 digital output value

] Read the CH2 digital output value

] Read the CH3 digital output value

] [Z. REMFR "J1" K2 K1 H2 K10 D10 K4 M300

* Error code display and reset processing

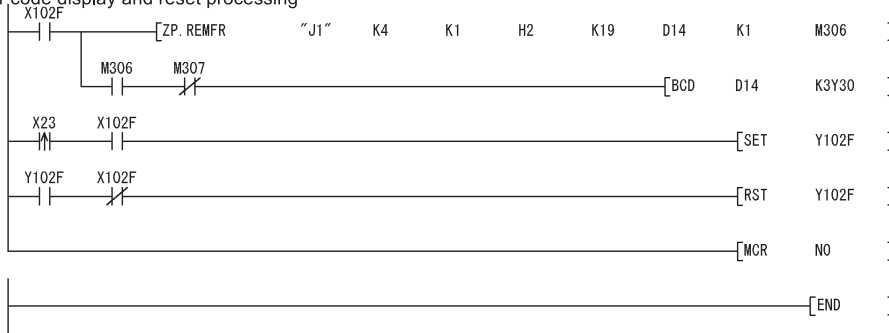

] Read the error code

] Output the error code in BCD

] Turn ON the error clear request (YF)

] Turn OFF the error clear request (YF)

] [MCR NO

] [END

6.5 Link Dedicated Instruction List

The following table outlines the instructions that can be used for the MELSECNET/H. For details on the format and program examples of each instruction, refer to the applicable section listed in the Reference section column.

List of link dedicated instructions

○: Can be used ×: Cannot be used

Instruction	Name	Executing station	Description	Target station	Reference section
		QCPU		Remote I/O station	
REMFR	Read remote I/O station intelligent function module buffer memory	○	<p>Reads data from the target remote I/O station intelligent function module buffer memory.</p>	○	Section 7.1.1 (1)
REMT0	Write remote I/O station intelligent function module buffer memory	○	<p>Writes data to the target remote I/O station intelligent function module buffer memory.</p>	○	Section 7.1.1 (1)
READ	Read other station word device	○	<p>Reads device data (16-bit unit) from a remote I/O station of the target network No.</p>	○	* 1
WRITE	Write other station word device	○	<p>Writes device data (16-bit unit) to a remote I/O station of the target network No.</p>	○	* 1

Instruction	Name	Execution station		Description	Target station		Reference section
		Process CPU	Redundant CPU * 2		Multiplexed remote master station	Multiplexed remote sub-master station	
SEND	Data send	○	×	<p>SEND: Writes data to the target station (network module) of the target network No.</p> <p>RECV: Reads the data sent by SEND to the CPU device.</p>	○	○	* 1
RECV	Data receive	○	×	<p>RECV: Reads the data sent by SEND to the CPU device.</p>	○	○	* 1
READ SREAD	Other station word device read	○	○	<p>Reads the CPU device data of the target station of the target network No. (in 16 bit units).</p>	○	○	* 1
WRITE SWRITE	Other station word device write	○	○	<p>Writes data to the CPU device of the target station of the target network No. (in 16 bit units). (SWRITE can turn ON the device of the target station.)</p>	○	○	* 1
REQ	Other station transient request	○	○	<p>Performs "remote RUN/STOP" or "clock data read/write" to the other station.</p>	○	○	* 1
RECVS	Message receive (1 scan completion)	○	×	<p>Receives the channel data, which was sent by SEND, within an interrupt program and reads that data to the CPU device immediately. Processing is completed when the instruction is executed.</p>	○	○	* 1

Instruction	Name	Execution station		Description	Target station		Reference section
		Process CPU	Redundant CPU * 2		Multiplexed remote master station	Multiplexed remote sub-master station	
ZNRD	Other station word device read	○	○	<p>[A-compatible instruction] Reads the CPU device data of the target station of the target network No.</p>	○	○	* 1
ZNWR	Other station word device write	○	○	<p>[A-compatible instruction] Writes data to the CPU device of the target station of the target network No.</p>	○	○	* 1
RRUN	Remote RUN	○	○	<p>Performs "remote RUN" to the CPU module of the other station.</p>	○	○	* 1
RSTOP	Remote STOP	○	○	<p>Performs "remote STOP" to the CPU module of the other station.</p>	○	○	* 1
RTMRD	Other station clock data read	○	○	<p>Performs "clock data read" to the CPU module of the other station.</p>	○	○	* 1

Instruction	Name	Execution station		Description	Target station		Reference section
		Process CPU	Redundant CPU * 2		Multiplexed remote master station	Multiplexed remote sub-master station	
RTMWR	Write clock data into other station	○	○	Performs "Write clock data" to the CPU module of the other station. 	○	○	*1

- *1: For details of the SEND, RECV, READ, SREAD, WRITE, SWRITE, REQ, RECVS, ZNRD, ZNWR, RRUN, RSTOP, RTMRD, and RTMWR instructions, refer to the Q Corresponding MELSECNET/H Network System Reference Manual (PLC to PLC network).
 The multiplexed remote master station or the current master station is accessible with each instruction by specifying the target station No. to "7DH" or "7EH" respectively.
- *2: If the Redundant CPU of the execution station executes the unusable instructions such as SEND, RECV, RECVS, to the target station once, it will not result in an error. However, if it executes the unusable instruction again, it will result in an error.
 Also, RRUN instruction and RSTOP instruction may result in an error on the Redundant CPU of the target station.
- *3: It is recommended to use SB0048 (ON: multiplexed remote master station) as an interlock signal when executing REMTO instruction, to refer to if the host station operates as a master.

POINT
<p>(1) Eight channels may be used with each link dedicated instruction. Hence, up to eight instructions can make simultaneous access to the intelligent function modules of the remote I/O station. It is recommend to combine GX Configurator's automatic refresh setting and cyclic transmission to access the data of the intelligent function module that is continuously accessed (e.g. the analog input value of the analog-digital converter module). (Refer to Section 6.3.)</p> <p>(2) Link dedicated instructions must be executed in online mode. Execution of the link dedicated instructions is not allowed in offline mode.</p> <p>(3) When the link dedicated instruction is used to access the other station programmable controller during network diagnosis, the execution of the link dedicated instruction may be delayed. After taking the following measures, perform network diagnosis processing and execute the link dedicated instruction.</p> <ul style="list-style-type: none"> • Execute the COM instruction. • Secure the communication processing security time for 2 to 3ms. For the High Performance model QCPU, Process CPU, and Redundant CPU, set it by the special register SD315. For the Universal model QCPU, set it by the service processing setting of the PLC parameter (PLC system) of GX Developer.

REMARKS

If the SREAD or SWRITE instruction is erroneously executed to a remote I/O station, the notification device to the target station is ignored and it is processed in the same manner as the READ or WRITE instruction.

6.6 Using the Link Special Relays (SB)/ Link Special Registers (SW)

The data linking information is stored in the link special relays (SB)/link special registers (SW).

They can be used by the sequence programs, or used for investigating faulty areas and the causes of errors by monitoring them.

The range that can be set by the user is SB/SW 0000H to 001FH.

The range that can be set by the system is SB/SW 0020H to 01FFH.

For more details, refer to Appendixes 2 and 3.

(1) Cyclic transmission stop/restart

Cyclic transmission stop/restart is executed through the GX Developer network tests, but it also can be executed with link special relay (SB) and link special register (SW). (Refer to Section 7.9.)

(a) Cyclic transmission stop/restart

(Cyclic transmission stop)

- 1) In the following link special register (SW), specify a station for stopping cyclic transmission.
 - Specification of target station
Link stop/startup direction content (SW0000)
 - Specification of station No.
Link stop/startup direction content (SW0001 to SW0004)
- 2) Turn System link stop (SB0003) ON.
- 3) When the network module accepts a request, Cyclic transmission stop acknowledgment status (system) (SB0052) is turned ON.
- 4) When the cyclic transmission stop is completed, Cyclic transmission stop completion status (system) (SB0053) is turned ON.
- 5) The station No. of the station that performed the cyclic transmission stop request is stored in Data linking stop request station (SW004A). (Saved in the station which received the stop request.)
- 6) If the cyclic transmission stop is completed abnormally, an error code will be stored in Data linking stop status (entire system) (SW0053).
- 7) Turn System link stop (SB0003) OFF.

(Cyclic transmission restart)

- 8) In the following link special register (SW), specify a station for restarting cyclic transmission
 - Specification of target station
Link stop/startup direction content (SW0000)
 - Specification of station No.
Link stop/startup direction content (SW0001 to SW0004)
- 9) Turn System link startup (SB0002) ON.
- 10) When the network module accepts a request, Cyclic transmission start acknowledgment status (system) (SB0050) is turned ON.
- 11) When the cyclic transmission restart is completed, Cyclic transmission start completion status (system) (SB0051) is turned ON.
- 12) If the cyclic transmission restart is completed abnormally, an error code will be stored in Data linking start status (entire system) (SW0051).
- 13) Turn System link startup (SB0002) OFF.

No.	Description	No.	Description
SB0002	System link startup	SW0000	Link stop/startup direction content
SB0003	System link stop	SW0001 to SW0004	
	—	SW004A	Data linking stop request station
SB0050	Cyclic transmission start acknowledgment status (system)		—
SB0051	Cyclic transmission start completion status (system)	SW0051	Data linking stop status (entire system)
SB0052	Cyclic transmission stop acknowledgment status (system)		—
SB0053	Cyclic transmission stop completion status (system)	SW0053	Data linking stop status (entire system)

(b) Cyclic transmission stop/restart of the host

(Cyclic transmission stop)

- 1) Turn Link stop (host) (SB0001) ON.
- 2) When the network module accepts a request, Cyclic transmission stop acknowledgment status (host) (SB004E) is turned ON.
- 3) When the cyclic transmission stop is completed, Cyclic transmission stop completion status (host) (SB004F) is turned ON.
- 4) If the cyclic transmission stop is completed abnormally, an error code will be stored in Data linking stop status (host) (SW004F).
- 5) Turn Link stop (host) (SB0001) OFF.

(Cyclic transmission restart)

- 6) Turn Link startup (host) (SB0000) ON.
- 7) When the network module accepts the request, Cyclic transmission start acknowledgment status (host) (SB004C) is turned ON.
- 8) When the cyclic transmission restart is completed, Cyclic transmission start completion status (host) (SB004D) is turned ON.
- 9) If the cyclic transmission restart is completed abnormally, an error code will be stored in Data linking start status (host) (SW004D).
- 10) Turn Link startup (host) (SB0000) OFF.

No.	Description	No.	Description
SB0000	Link startup (host)	—	—
SB0001	Link stop (host)		
SB004C	Cyclic transmission start acknowledgment status (host)		
SB004D	Cyclic transmission start completion status (host)	SW004D	Data linking start status (host)
SB004E	Cyclic transmission stop acknowledgment status (host)	—	
SB004F	Cyclic transmission stop completion status (host)	SW004F	Data linking stop status (host)

(2) Checking data link

The data link status is checked through the GX Developer network diagnostics, but it also can be checked with link special relay (SB) and link special register (SW). (Refer to Sections 8.1.1 and 8.1.2.)

(a) Check the data link status of other stations

- 1) Link scan time etc., can be checked in SW005A to SW005B and SW006B to SW006D.
- 2) If an error occurs to data link, either of the following link special relays (SB) will be turned ON.
 - Baton pass status of each station (SB0070)
 - Cyclic transmission status of each station (SB0074)
- 3) When Baton pass status of each station (SB0070) is turned ON, the station No. of a station where an error has occurred is stored in Baton pass status of each station (SW0070 to SW0073).
When Cyclic transmission status of each station (SB0074) is turned ON, the station No. of a station where an error has occurred is stored in Cyclic transmission status of each station (SW0074 to SW0077).
- 4) The details of the cause of an error can be checked with the link special relay (SB) and link special register (SW) of the station No. for a station where the error has occurred. (Refer to (2)(b) in this Section.)

No.	Description	No.	Description
—		SW005A	Maximum baton pass station
		SW005B	Maximum cyclic transmission station
		SW006B	Maximum link scan time
		SW006C	Minimum link scan time
		SW006D	Current link scan time
SB0070	Baton pass status of each station	SW0070 to SW0073	Baton pass status of each station
SB0074	Cyclic transmission status of each station	SW0074 to SW0077	Cyclic transmission status of each station

(b) Checking data link status of the host

- 1) Link scan time etc., can be checked in SW005A to SW005B and SW006B to SW006D.
- 2) If an error occurs to data link, either of the following link special relays (SB) will be turned ON.
 - Baton pass status (host) (SB0047)
 - Host data link status (SB0049)
- 3) The cause of an error is stored in the following link special registers (SW).
 - Baton pass status (host) (SW0047)
 - Cause of baton pass interruption (SW0048)
 - Cause of data link stop (SW0049)

No.	Description	No.	Description
SB0047	Baton pass status (host)	SW0047	Baton pass status (host)
	—	SW0048	Cause of baton pass interruption
SB0049	Host data link status	SW0049	Cause of data link stop
		SW005A	Maximum baton pass station
		SW005B	Maximum cyclic transmission station
		SW006B	Maximum link scan time
		SW006C	Minimum link scan time
		SW006D	Current link scan time

(3) Checking transient transmission errors

Transient transmission errors are checked through the GX Developer network diagnostics, but they also can be checked with link special relays (SB) and link special registers (SW). (Refer to Section 8.1.4)

- 1) When a transient transmission error occurs, Transient error (SB00EE) is turned ON.
- 2) An error code is stored in Transient transmission error history (SW00F0 to SW00FF).
- 3) The number of transient transmission errors is stored in Transient transmission error (SW00EE).
- 4) An exact error code storage area in Transient transmission error history (SW00F0 to SW00FF) is stored in Transient transmission error pointer (SW00EF).
- 5) If Transient transmission error area setting (SB000B) is turned ON, the error code stored in Transient transmission error history (SW00F0 to SW00FF) is retained. (Not overwritten even if another error occurs.)
- 6) Turning ON Clear transient transmission errors (SB000A) will clear the following areas:
 - Transient transmission error (SW00EE)
 - Transient transmission error pointer (SW00EF)

No.	Description	No.	Description
SB000A	Clear transient transmission errors	—	
SB000B	Transient transmission error area setting		
SB00EE	Transient error	SW00EE	Transient transmission error
—		SW00EF	Transient transmission error pointer
		SW00F0 to SW00FF	Transient transmission error history

(4) Checking cables for faults

The cable condition can be checked not only in the network diagnostics of GX Developer but also with link special relays (SB) and link special registers (SW). (Refer to Section 8.1.4.)

- 1) When a communication error occurs due to a cable fault, the error count is stored in any of the link special registers (SW) in the table below.
- 2) Turning ON Clear retry count (SB0005) will clear Number of retries (SW00C8 and SW00C9).
Turning ON Clear communication error count (SB0006) will clear Communication errors (SW00B8 to SW00C7).
Turning ON Clear forward loop transmission errors (SB0007) will clear Line error on the forward loop side (SW00CC).
Turning ON Clear reverse loop transmission errors (SB0008) will clear Line error on the reverse loop side (SW00CD).

No.	Description	No.	Description
SB0005	Clear retry count	—	—
SB0006	Clear communication error count		
SB0007	Clear forward loop transmission errors		
SB0008	Clear reverse loop transmission errors		
—	—	SW00B8	UNDER on the forward loop side/coaxial bus UNDER
		SW00B9	CRC on the forward loop side/coaxial bus CRC
		SW00BA	OVER on the forward loop side/coaxial bus OVER
		SW00BB	Short frame on the forward loop side/coaxial bus short frame
		SW00BC	Abort on the forward loop side (AB, IF)/coaxial bus abort (AB, IF)
		SW00BD	Timeout on the forward loop side (TIME)/ coaxial bus timeout (TIME)
		SW00BE	Receiving 2k bytes or more on forward loop side (DATA)/coaxial bus receiving 2k bytes or more (DATA)
		SW00BF	DPLL error on the forward loop side/coaxial bus DPLL error
		SW00C0	UNDER on the reverse loop side
		SW00C1	CRC on the reverse loop side
		SW00C2	OVER on the reverse loop side
		SW00C3	Short frame on the reverse loop side
		SW00C4	Abort on the reverse side (AB, IF)
		SW00C5	Timeout on the reverse loop side (TIME)
		SW00C6	Receiving 2k bytes or more on reverse loop side (DATA)
		SW00C7	DPLL error on reverse loop side
SW00C8	Number of retries on the forward loop side/ coaxial bus retries error		
SW00C9	Number of retries on the reverse loop side		
SW00CC	Line error on the forward loop side		
SW00CD	Line error on the reverse loop side		

(5) Checking the forward/reverse loop in the optical loop system

The forward/reverse loop in the optical loop system can be checked not only in the network diagnostics of GX Developer but also with link special relays (SB) and link special registers (SW). (Refer to Sections 8.1.1 and 8.1.2.)

(a) Checking the forward/reverse loop of another station

- 1) When an error occurs on the forward or reverse loop, the following link special relay (SB) is turned ON.
 - Forward loop status (SB0091)
 - Forward loop status of remote master station (SB0092) (Except the remote master station)
 - Reverse loop status (SB0095)
 - Reverse loop status of remote master station (SB0096) (Except the remote master station)
- 2) The station where an error occurred can be identified with the following link special registers (SW).
 - Forward loop status of each station (SW0091 to SW0094)
 - Reverse loop status of each station (SW0095 to SW0098)
- 3) If loop switching occurs, the cause of the loop switching is stored in Loop switch data (SW00D0 to SW00DF).
The position of the loop switch data storage can be checked with Loop switch data pointer (SW00CF).
- 4) Cable disconnection or station failure causes loopback.
When loopback occurs, any of the following link special relays (SB) is turned ON.
 - Forward loop loopback (SB0099)
 - Reverse loop loopback (SB009A)
- 5) The station where loopback occurred can be identified with the following link special registers (SW).
 - Loopback station (forward loop side) (SW0099)
 - Loopback station (reverse loop side) (SW009A)
- 6) An incorrect optical fiber cable connection (IN-IN, OUT-OUT) can be checked with Loop usage status of each station (SW009C to SW009F).
- 7) The count of loop switching can be checked with Number of loop switches (SW00CE).
- 8) Turning ON Clear loop switch count (SB0009) can clear SW00CE to SW00DF.

No.	Description	No.	Description
SB0009	Clear loop switch count		—
SB0091	Forward loop status	SW0091 to SW0094	Forward loop status of each station
SB0092	Forward loop status of remote master station		
SB0095	Reverse loop status	SW0095 to SW0098	Reverse loop status of each station
SB0096	Reverse loop status of remote master station		
SB0099	Forward loop loopback	SW0099	Loopback station forward loop side)
SB009A	Reverse loop loopback	SW009A	Loopback station (reverse loop side)
		SW009C to SW009F	Loop usage status of each station
		SW00CE	Number of loop switches
		SW00CF	Loop switch data pointer
		SW00D0 to SW00DF	Loop switch data

(b) Checking the forward/reverse loop of the host

- 1) When an error occurs on the forward or reverse loop, Host loop status (SB0090) turns ON.
- 2) If loopback occurs, the cause of the loopback is stored in Loop switch data (SW00D0 to SW00DF).
The position of the loop switch data storage can be checked with Loop switch data pointer (SW00CF).
- 3) The loop status of the host can be checked with Loopback information (SW0090).
- 4) The count of loop switching can be checked with Number of loop switches (SW00CE).
- 5) Turning ON Clear loop switch count (SB0009) can clear SW00CE to SW00DF.

No.	Description	No.	Description
SB0009	Clear loop switch count	—	
SB0090	Host loop status	SW0090	Loopback information
—		SW00CE	Number of loop switches
		SW00CF	Loop switch data pointer
		SW00D0 to SW00DF	Loop switch data

(6) Checking the offline test status

The test status is checked through the LEDs on the network module, but it also can be checked with link special relays (SB) and link special registers (SW).

(Refer to Section 4.7.)

(a) Requesting side

- 1) When the offline test is instructed, Offline test instruction (SB00AC) is turned ON.
An offline test item and a faulty station number are stored in Offline test execution item/faulty station (requesting side) (SW00AC).
- 2) Upon completion of the offline test, Offline test completion (SB00AD) is turned ON.
The offline test result is stored in Offline test result (requesting side) (SW00AD).

No.	Description	No.	Description
SB00AC	Offline test instruction	SW00AC	Offline test execution item/faulty station (requesting side)
SB00AD	Offline test completion	SW00AD	Offline test result (requesting side)

(b) Responding side (the forward/reverse loop test only)

- 1) When a response is made to an offline test request from the requesting side, Offline test response (SB00AE) is turned ON.
An offline test item is stored in Offline test execution item (responding side) (SW00AE).
- 2) Upon completion of the offline test, Offline test response completion (SB00AF) is turned ON.
The offline test result is stored in Offline test result (responding side) (SW00AF).

No.	Description	No.	Description
SB00AE	Offline test response	SW00AE	Offline testing Execution item (Response side)
SB00AF	Offline test response completion	SW00AF	Offline testing results (Response side)

(7) Checking the online test status

The test status is checked through LED of the network module main frame, but it also can be checked with link special relay (SB) and link special register (SW).
(Refer to Section 4.10.)

(a) Requesting side

- 1) When the online test is instructed, Online test instruction (SB00A8) is turned ON.
An online test item and a faulty station number are stored in Online test execution item/faulty station (requesting side) (SW00A8).
- 2) Upon completion of the online test, Online test completion (SB00A9) is turned ON.
The online test result is stored in Online test result (requesting side) (SW00A9).

No.	Description	No.	Description
SB00A8	Online test instruction	SW00A8	Online test execution item/faulty station (requesting side)
SB00A9	Online test completion	SW00A9	Online test result (requesting side)

(b) Responding side

- 1) When a response is made to an online test request from the requesting side, Online test response (SB00AA) is turned ON.
An online test item is stored in Online test execution item (responding side) (SW00AA).
- 2) Upon completion of the online test, Online test response completion (SB00AB) is turned ON.
The online test result is stored in Online test result (responding side) (SW00AB).

No.	Description	No.	Description
SB00AA	Online test response instruction	SW00AA	Online test execution item (responding side)
SB00AB	Online test response completion	SW00AB	Online test result responding side)

(8) Checking parameter status

The reflection status and setting contents of parameters can be checked with link special relay (SB) and link special register (SW).

(a) Checking parameter status of other stations

- 1) Check the following link special relay (SB) and link special register (SW) with the remote master station.
 - When receiving parameters is completed, Parameter communication status of each station (SB0078) is turned OFF.
 - Stations that are still communicating parameters can be checked with Parameter communication status of each station (SW0078 to SW007B).
- 2) Check the following link special relay (SB) and link special register (SW) with the remote master station.
 - When parameters have an error, Parameter status of each station (SB007C) is turned ON.
 - The station No. of the faulty station is stored in Parameter error status of each station (SW007C to SW007F).
- 3) Details of the parameters for each station can be checked with the link special relay (SB) and link special register (SW) of each station. (Refer to (8)(b) in this Section.)

No.	Description	No.	Description
SB0078	Parameter communication status of each station	SW0078 to SW007B	Parameter communication status of each station
SB007C	Parameter status of each station	SW007C to SW007F	Parameter error status of each station

(b) Checking the parameter status of the host (including the switch setting on the network module)

- 1) Upon completion of receiving parameters, Parameter receive status (SB0054) is turned OFF.
- 2) If any error is found in the parameters, the following link special relays (SB) are turned ON.
 - Setting information (host) (SB0045)
 - Received parameter error (SB0055)
- 3) An error code is stored in Parameter setting status (SW0055).
- 4) If the host is a remote I/O station, the presence of intelligent function parameters can be checked by Parameter information (SW0054).

No.	Description	No.	Description
SB0045	Setting information (host)		—
SB0054	Parameter receive status	SW0054	Parameter information
SB0055	Received parameter error	SW0055	Parameter setting status

- 5) When the parameters are reflected in the network module, contents of parameters are stored in the following link special relay (SB) and link special register (SW).

No.	Description	No.	Description
SB0040	Network type (host)	SW0040	Network No.
	—	SW0042	Station No.
SB0043	Online switch (host)	SW0043	Mode status
SB0044	Station setting (host)	SW0044	Station setting
SB0046	Data link operation designation result (host)	SW0046	Module type
SB0048	Remote master station status (host)		—
SB0056	Communication status	SW0056	Current remote master station
	—	SW0057	Designated remote master station
SB0058	Operation designation at fault of (multiplexed remote master station)		—
	—	SW0059	Total number of link stations
SB005B	END asynchronous settings		—
SB0064	Reserved station designation	SW0064 to SW0067	Reserved station designation
SB0068	Communication mode	SW0068	Communication mode
SB0069	Multiplex transmission designation		—
SB006B	Multiplex remote function designation		—

(9) Checking the remote master station's CPU module and remote I/O station statuses (Error detection of remote I/O stations)

The status check can be performed not only with the network diagnostics in GX Developer but also with link special relays (SB) and link special registers (SW). (Refer to Sections 8.1.2 and 8.1.3.)

(a) Checking the remote I/O station status (Error detection of remote I/O stations)

- 1) Baton pass status of each station (SB0070) turns ON when the power is turned OFF or watchdog timer error is occurred on a remote I/O station.
The station No. of the station where the power is turned OFF or watchdog timer error is occurring is stored in baton pass status of each station (SB0070 to SW0073).
- 2) When a stop error occurs on a remote I/O station, CPU operation status of each station (1) (SB0080) is turned ON.
The station No. of the station where a stop error is occurring is stored in CPU operation status of each station (1) (SW0080 to SW0083).
- 3) When a continuation error occurs on a I/O station, CPU operation status of each station (2) (SB0088) is turned ON.
The station No. of the station where a continuation error is occurring is stored in CPU operation status of each station (2) (SW0088 to SW008B).
- 4) Turning ON Clear minor errors (SB000F) clears continuation errors occurred on remote I/O stations.

No.	Description	No.	Description	Description of the errors detectable on remote I/O stations
SB000F	Clear minor errors		—	—
SB0070	Baton pass status of each station	SW0070 to SW0073	Baton pass status of each station	Powering OFF (disconnection) Watchdog timer error
SB0080	CPU operation status of each station (1)	SW0080 to SW0083	CPU operation status of each station (1)	Stop error
SB0088	CPU operation status of each station (2)	SW0088 to SW008B	CPU operation status of each station (2)	Continuation error

POINT

Use link special relays (SB) for detection of errors of overall network, and link special registers (SW) for detection of errors of a specific station.

(b) Checking the remote master station's CPU module status

- 1) Whether the CPU module is in the RUN or STOP status can be checked in CPU RUN status of the remote master station (SB0085). (SB0086 for the multiplexed remote sub-master station)
- 2) When a continuation error occurs with the CPU module, Host CPU status (1) (SB004A) is turned ON.
- 3) When a stop error occurs with the CPU module, Host CPU status (2) (SB004B) is turned ON.
- 4) The CPU module status can be checked with Host CPU status (SW004B).

No.	Description	No.	Description
SB004A	Host CPU status (1)	—	
SB004B	Host CPU status (2)	SW004B	Host CPU status
SB0085	CPU RUN status of the remote master station	—	
SB0086	Remote sub-master station CPU RUN status		

(10) Checking the multiplex transmission status

The multiplex transmission status is checked through the GX Developer network diagnostics, but it also can be checked with link special relay (SB) and link special register (SW). (Refer to Section 8.1.3.)

- 1) If the "With multiplex transmission" box is checked in the supplementary settings of common parameters, Multiplex transmission designation (SB0069) is turned ON.
- 2) An execution of the multiplex transmission function turns ON Multiplex transmission status (SB006A).
- 3) Data showing the forward and reverse loop states during multiplex transmission are stored in the following link special registers (SW).
 - Multiplex transmission status (1) (SW00B0 to SW00B3)
 - Multiplex transmission status (2) (SW00B4 to SW00B7)

No.	Description	No.	Description
SB0069	Multiplex transmission designation	—	
SB006A	Multiplex transmission status	SW00B0 to SW00B3	Multiplex transmission status (1)
		SW00B4 to SW00B7	Multiplex transmission status (2)

(11) Operation status check and operation switching of the multiplexed remote master function

The operation of the multiplexed remote master function can be checked or switched with link special relays (SB) and link special registers (SW).

(a) Checking the operation status of the multiplexed remote master station

- 1) If an error occurs in data link, any of the following link special relays (SB) is turned ON.
 - Baton pass status of the remote master station (SB0071)
 - Remote sub-master station transient transmission status (SB0072)
 - Cyclic transmission status of the remote master station (SB0075)
 - Remote sub-master station cyclic transmission status (SB0076)
- 2) The type of the station that is controlling the cyclic transmission (remote master or remote sub-master station) can be checked in Remote master station cyclic transmission control status (SB0077).

No.	Description	No.	Description
SB0071	Baton pass status of the remote master station	—	
SB0072	Remote sub-master station transient transmission status		
SB0075	Cyclic transmission status of the remote master station		
SB0076	Remote sub-master station cyclic transmission status		
SB0077	Remote master station cyclic transmission control status		

(b) Operation switching of the multiplexed remote master station

- 1) When Remote sub-master station switching command (SB0014) is turned ON, the remote sub-master station running as a master is forced to operate as a sub-master station.
- 2) When the remote sub-master station running as a master accepts the switching, Remote sub-master station switching acceptance status (SB01C4) is turned ON.
- 3) Upon completion of switching from master operation to sub-master operation, Remote sub-master station switching status (SB01C5) is turned ON.
- 4) If the switching fails, an error code is stored in Remote sub-master station switching result (SW01C4).

No.	Description	No.	Description
SB0014	Remote sub-master station switching command	SW01C4	Remote sub-master station switching result
SB01C4	Remote sub-master station switching acceptance status		
SB01C5	Remote sub-master station switching status		

(c) Checking device ranges of the multiplexed remote master and sub-master stations

- 1) When Send LY/Receive LX device numbers of the multiplexed remote master and sub-master stations (SW01C8 to SW01CF) become valid, Send/receive device number valid/invalid status (SB01C8) is turned ON.
- 2) The send/receive device numbers of the multiplexed remote master and sub-master stations can be checked in SW01C8 to SW01CF.

No.	Description	No.	Description
SB01C8	Send/receive device number valid/invalid status	SW01C8	Send LY device number
		SW01C9	Receive LX device number
		SW01CC	Send LB device number
		SW01CD	Receive LB device number
		SW01CE	Send LW device number
		SW01CF	Receive LW device number

(12) Checking the redundant multiplexed remote master function support and setting

With link special relays (SB) and link special registers (SW), whether the multiplexed remote master function is supported can be checked and relevant settings can be configured.

- 1) When the network module supports the redundant multiplexed remote I/O networks, Host station's redundant function support information (SB0041) is turned ON.
- 2) To set the time taken from detection of a data link stop until system switching is requested in the redundant system, set a time value in System switching monitoring time setting (SW0018).
- 3) If System switching monitoring time setting valid flag (SB0018) is turned ON, System switching monitoring time setting (SW0018) is enabled.

No.	Description	No.	Description
SB0018	System switching monitoring time setting valid flag	SW0018	System switching monitoring time setting
SB0041	Host station's redundant function support information		—

(13) Setting a link dedicated instruction and checking the processing result

With link special relays (SB) and link special registers (SW), link dedicated instructions can be set and the processing results can be checked.

- 1) Link dedicated instructions can be set with the following link special registers (SW).
 - Number of retries (SW001C)
 - Retry interval (SW001D)
 - Number of gates (SW001E)
- 2) Processing results of the send/receive instructions are stored in the following link special registers (SW).
 - Send/receive instruction (1) processing result (SW0031)
 - Send/receive instruction (2) processing result (SW0033)
 - Send/receive instruction (3) processing result (SW0035)
 - Send/receive instruction (4) processing result (SW0037)
 - Send/receive instruction (5) processing result (SW0039)
 - Send/receive instruction (6) processing result (SW003B)
 - Send/receive instruction (7) processing result (SW003D)
 - Send/receive instruction (8) processing result (SW003F)

No.	Description	No.	Description
		SW001C	Number of retries
		SW001D	Retry interval
		SW001E	Number of gates
		SW0031	Send/receive instruction (1) processing result
		SW0033	Send/receive instruction (2) processing result
		SW0035	Send/receive instruction (3) processing result
		SW0037	Send/receive instruction (4) processing result
		SW0039	Send/receive instruction (5) processing result
		SW003B	Send/receive instruction (6) processing result
		SW003D	Send/receive instruction (7) processing result
		SW003F	Send/receive instruction (8) processing result

(14) Checking the communication status between the network module and the CPU module

The communication status between the network module and the CPU module can be checked with the link special relay (SB) and the link special register (SW).

(a) Checking the error details

- 1) When an error occurs in the communication between the network module and the CPU module, Module status (SB0020) turns ON.
- 2) An error code is stored in Module status (SW0020).

No.	Description	No.	Description
SB0020	Module status	SW0020	Module status

(b) Checking the external power supply status

Whether external power is supplied to the host station or not can be checked with Power supply status of host (SB0042).

External power supply to other stations can be checked with Power supply status of each station (SW008C to SW008F).

No.	Description	No.	Description
SB0042	Power supply status of host	SW008C to SW008F	Power supply status of each station

7 APPLICATION FUNCTIONS

When applying the program examples introduced in this chapter to the actual system, make sure to examine the applicability and confirm that it will not cause system control problems.

Chapter 3

Basic functions

Cyclic transmission function (Periodic communication)	Communicating with I/O module	Section 3.2.1 (1)
	Communicating with intelligent function module	Section 3.2.1 (2)
RAS functions	Output reset function for communication errors	Section 3.2.2 (1)
	Hardware error time CPU operation mode setting	Section 3.2.2 (2)
	Automatic return function	Section 3.2.2 (3)
	Loop back function (Optical loop system)	Section 3.2.2 (4)
	Station detach function (Coaxial bus systems)	Section 3.2.2 (5)
	Transient transmission enabled even at CPU module error	Section 3.2.2 (6)
	Checking the transient transmission abnormal direction time	Section 3.2.2 (7)
	Diagnostic functions	Section 3.2.2 (8)
	Redundant power supply on a remote I/O station	Section 3.2.2 (9)
	Online module change on a remote I/O station	Section 3.2.2 (10)

Chapter 7

Application functions

Application functions	Transient transmission function (Non-periodic communication)	Link dedicated instruction	Reading/writing remote I/O station intelligent function module buffer memory (REMFR/REMTO)	Section 7.1.1 (1)
	Remote I/O station system monitor			Section 7.2
	Device test for remote I/O station			Section 7.3
	Multiplex transmission function (Optical loop system)			Section 7.4
	Return sequence station number setting function			Section 7.5
	Reserved station function			Section 7.6
	Interrupt settings			Section 7.7
	I/O assignment function			Section 7.8
	Stopping/restarting the cyclic transmission and stopping link refreshing (Network test)			Section 7.9
	Multiplexed remote master function (Process PU)			Section 7.10
	Multiplexed remote master function for redundant system (Redundant CPU)			Section 7.11
	Remote password			Section 7.12
	Network diagnostics (Network monitor)			Section 8.1

※: In the application functions, there are executable functions that can be used by setting the parameters to either the remote master station or remote I/O station. It is possible to confirm whether the parameters are set to either the remote master station or remote I/O station by using the table on the heading for each function.

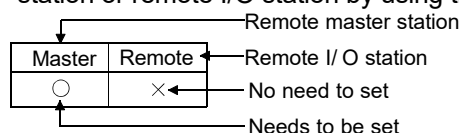

7.1 Transient Transmission Function (Non-Periodical Communication)

The transient transmission function performs data communication only when it is requested between stations.

The transient transmission function can be requested with the link dedicated instructions (REMFR, REMTO, READ and WRITE) GX Developer, the intelligent function module, etc.

In the MELSECNET/H, data communication can be performed with other stations having the same network number (the same network as where the host is connected), as well as with stations having other network numbers.

- 1) Transient transmission function to a station on the same network

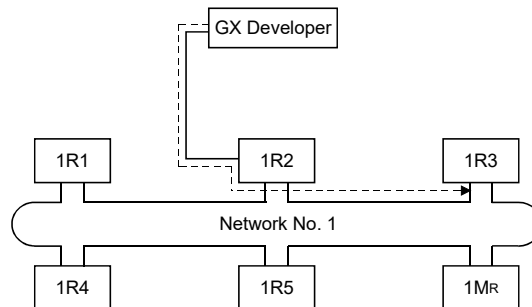

- 2) Transient transmission to stations on other networks (routing function)
In this case, the routing parameters must be set for the request source and relay stations.

When the source of the request is a remote I/O station, there is no need to set the "routing parameters" in the remote I/O station of the request source.

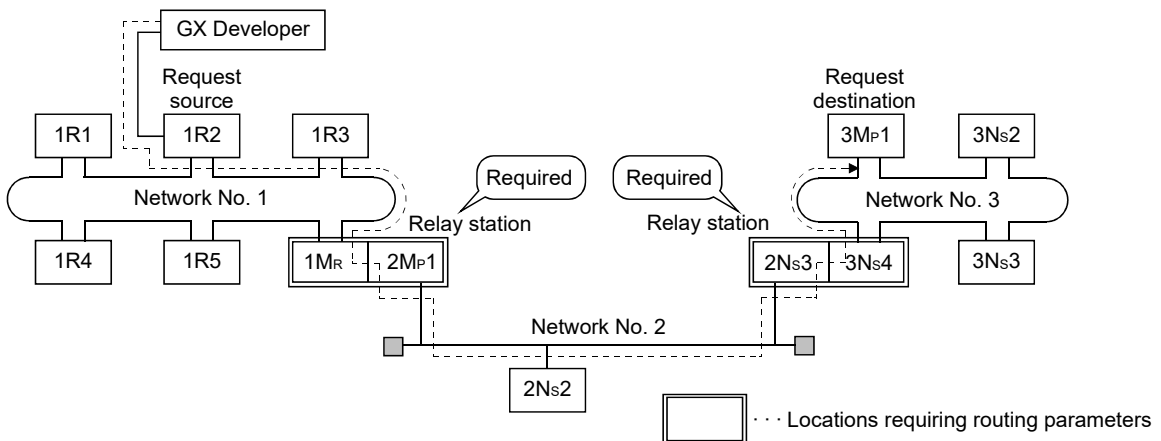

POINT
A remote I/O station can only become a request source and request destination.
Do not set the relay station.

For details about routing, refer to the Q corresponding MELSECNET/H Network System Reference Manual (PLC to PLC network).

7.1.1 Link dedicated instruction

(1) Reading/writing remote I/O station intelligent function module buffer memory (Z(P).REMFR/ Z(P).REMTO)

This section describes the REMFR/REMTO instruction format.

For a program example using the REMFR/REMTO instruction, refer to Section 6.4.2.

The REMFR instruction reads the data from the buffer memory of the intelligent function module mounted to the remote I/O station.

The REMTO instruction writes the data to the intelligent function module buffer memory mounted to the remote I/O station.

POINT
(1) The B/W for the handshake that is required when writing the remote I/O station intelligent function module buffer memory in a MELSECNET/10 network is not needed with REMFR/REMTO instructions. However, they have to be set if input/output X/Y is to operate as a system.
(2) Link dedicated instructions including REMFR/REMTO cannot use the CPU module local device and "use same file as program" as selected file register.
(3) Turn off the executing link instruction after the completion device turns on.

(a) Instruction format

1) Z(P).REMFR (Network No. designation)

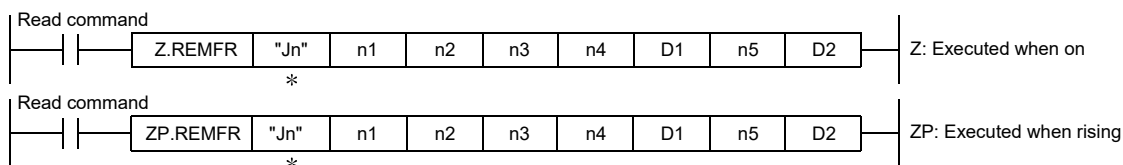

*: If the originating station is a Universal model QCPU, ""(double quotation) for the first argument can be omitted.

	Description of setting	Setting range
Jn	Target network No.	1 to 239
(n1)	Channel number	1 to 8 Word device *2
(n2)	Target number	1 to 64 Word device *2
(n3)	Start address input/output number for target intelligent function module The upper 3 digits of the 4-digit expression designates the first address input/output number for the intelligent function module mounted to the remote I/O station that is to be the target.	0 to FE _H Word device *2
(n4)	Read buffer memory start address Designates the start address of the buffer memory for the read destination intelligent function module.	Constant (K, H) Word device *2
(D1)	Read data storage start address device (Host) Designates the host start address device for storing the read data.	Word device *2
(n5)	Number of read data points (word units)	1 to 960 Word device *2
(D2)	Read completion device (Host) Designates the host device to be set to 1 scan on by the read completion. (D2) OFF: Not completed ON: Completed (D2) + 1 OFF: Normal ON: Abnormal	Bit device *1 Word device bit designation *3

*1: Bit device X, Y, M, L, F, V, B

*2: Word device T, C, D, W, ST, R, ZR

*3: Word device bit designation Word device.bit number

2) Z(P).REMT0
(Network No. designation)

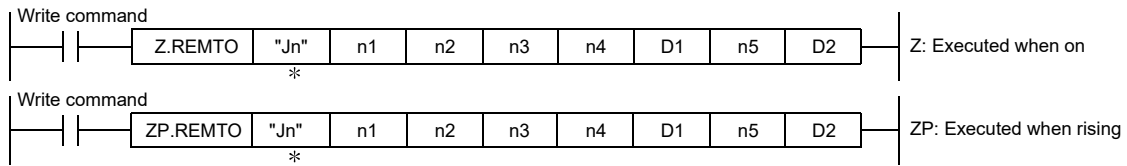

*: If the originating station is a Universal model QCPU, ""(double quotation) for the first argument can be omitted.

	Description of setting	Setting range
Jn	Target network No.	1 to 239
(n1)	Channel number	1 to 8 Word device *2
(n2)	Target number	1 to 64 Word device *2
(n3)	Start address input/output number for target intelligent function module The upper 3 digits of the 4-digit expression designates the start address input/output number for the intelligent function module mounted to the remote I/O station that is to be the target.	0 to FE _H Word device *2
(n4)	Write buffer memory start address Designates the start address of the buffer memory for the write destination intelligent function module.	Constant (K, H) Word device *2
(D1)	Write data storage start address device (Host) Designates the host start address device for storing the written data.	Word device *2
(n5)	Number of write data points (word modules)	1 to 960 Word device *2
(D2)	Write completion device (Host) Designates the host device to be set to 1 scan on by the write completion. (D2) OFF: Not completed ON: Completed (D2) + 1 OFF: Normal ON: Abnormal	Bit device *1 Word device bit designation *3

*1: Bit device X, Y, M, L, F, V, B

*2: Word device T, C, D, W, ST, R, ZR

*3: Word device bit designation Word device.bit number

(b) Instruction execution timing

1) Normal completion
(REMFR instruction)

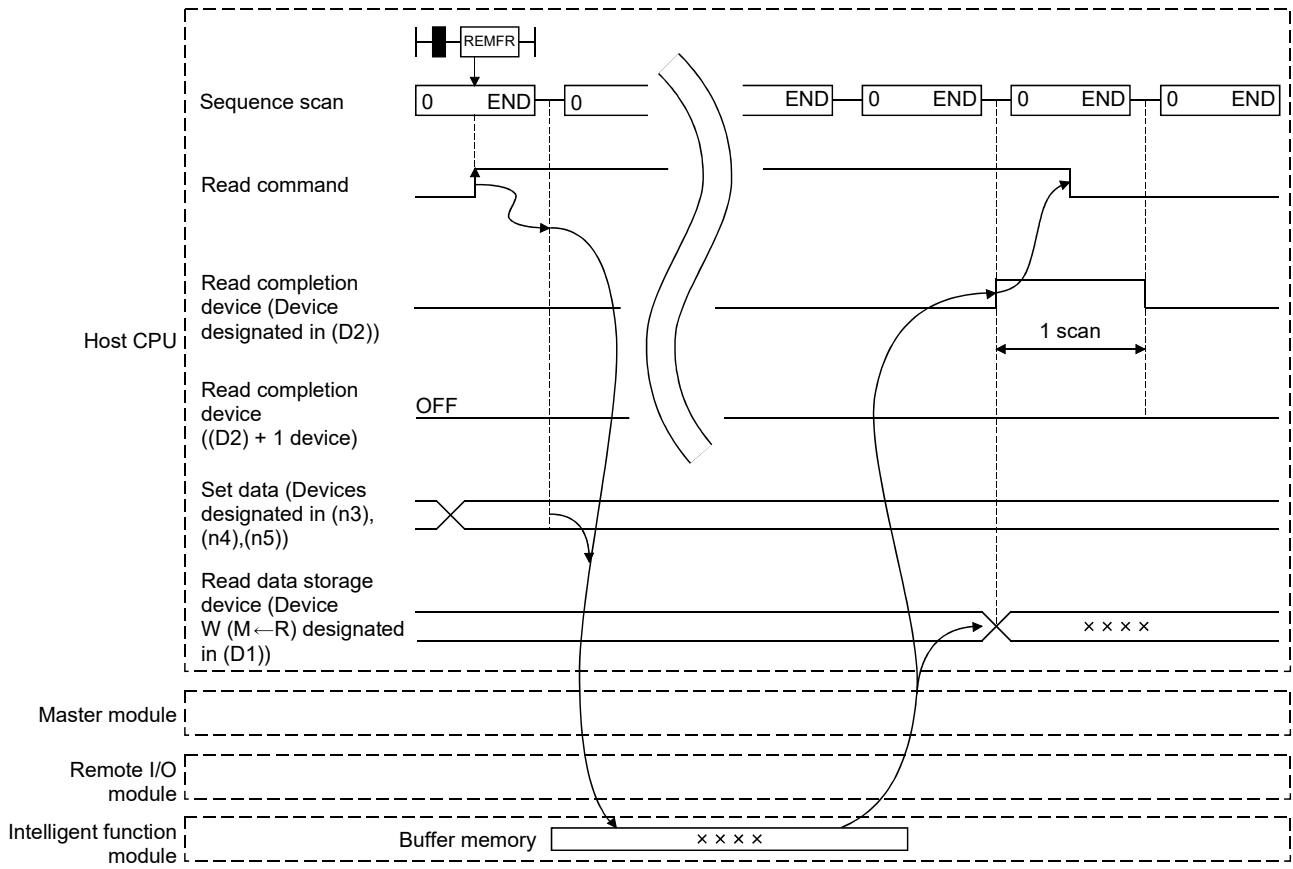

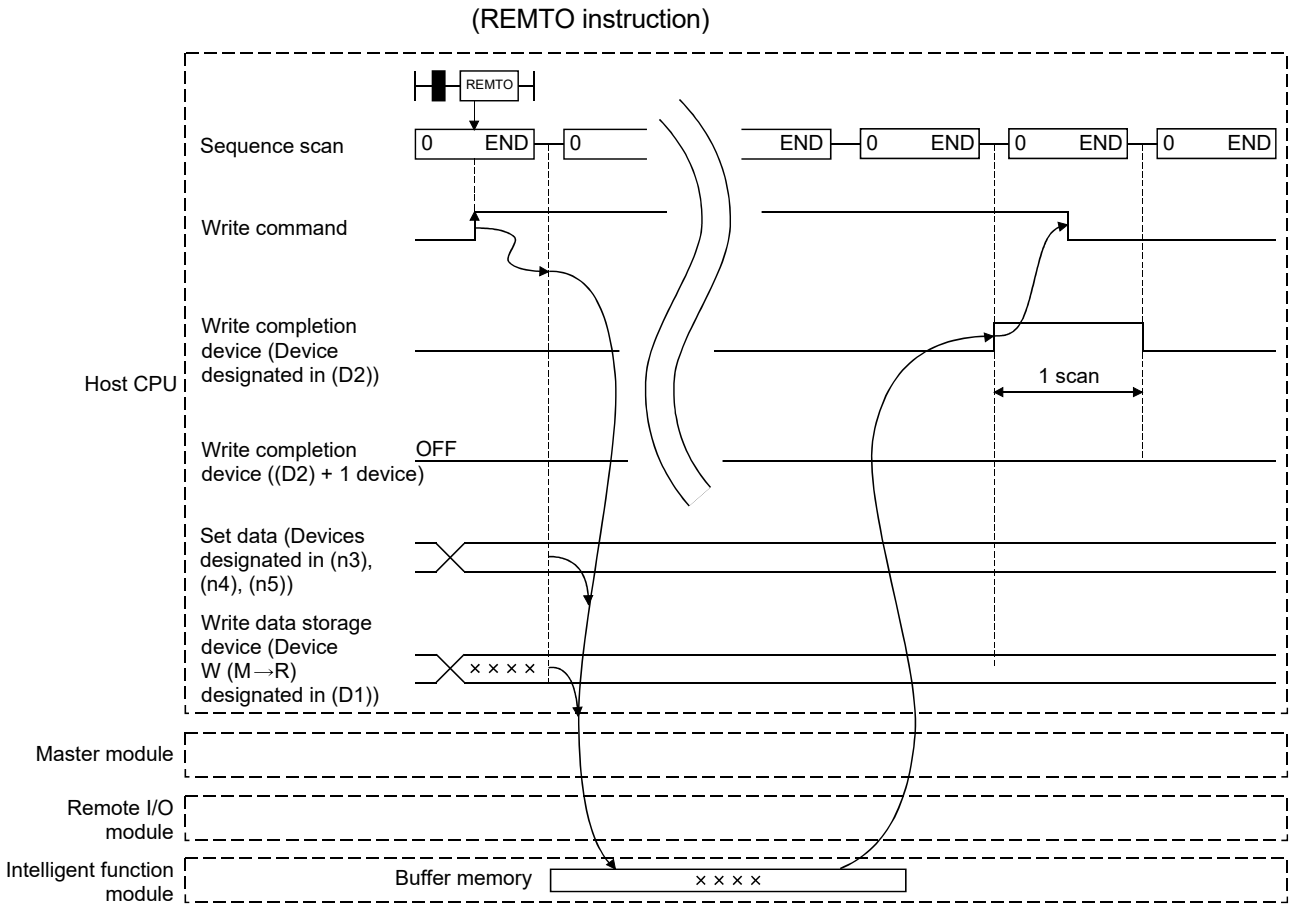

2) Abnormal completion
(REMFR instruction)

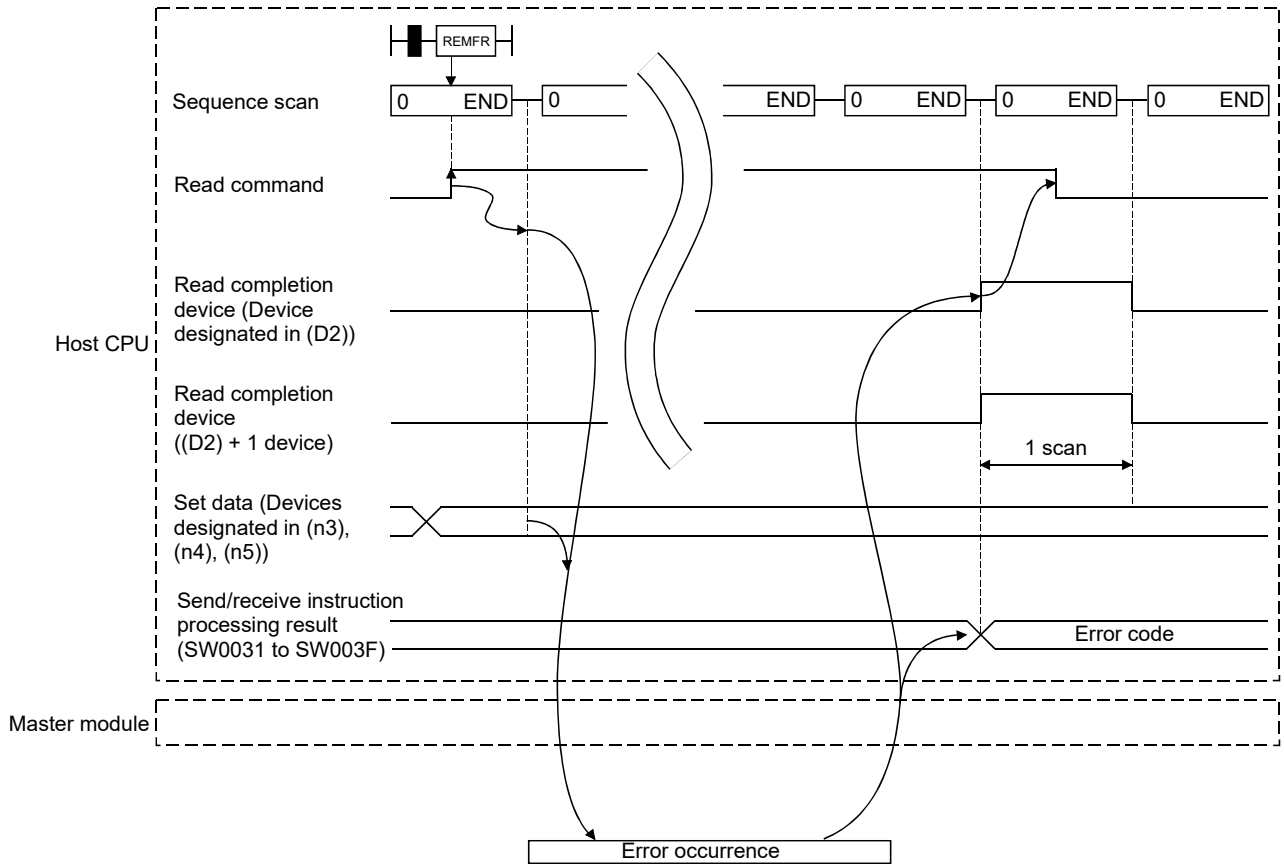

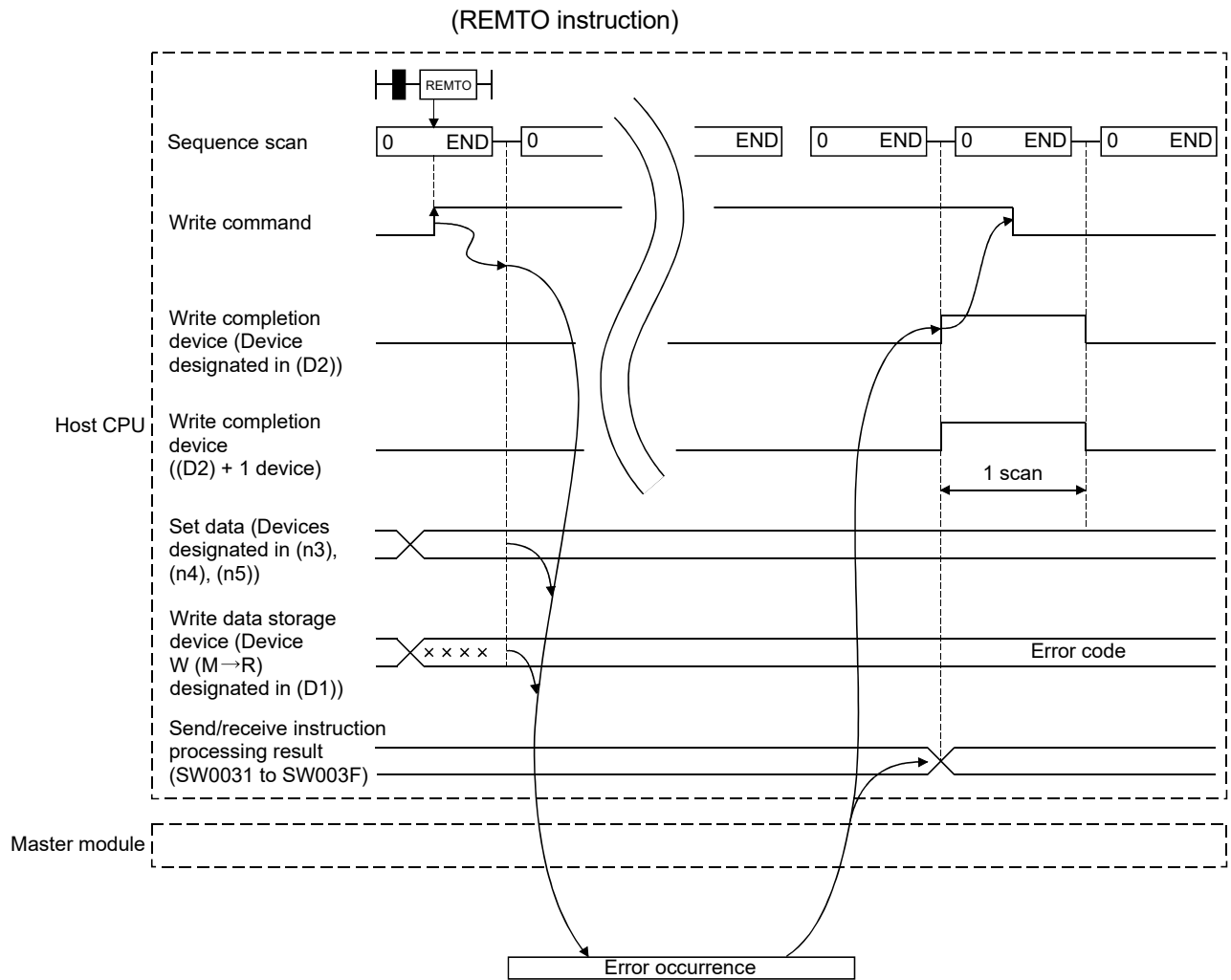

7.2 Remote I/O Station System Monitor

With the remote I/O network, the intelligent function module mounted to a remote I/O station can be monitored on the system monitor of GX Developer.

By using this, it is possible to easily diagnose the intelligent function module on the remote I/O station. For details on operating the system monitor, please refer to the operating manual for GX Developer.

There are 3 methods for performing system monitoring.

- (1) Connecting GX Developer directly to the remote I/O module
Select "Remote I/O" in connection destination PLC type for GX Developer.

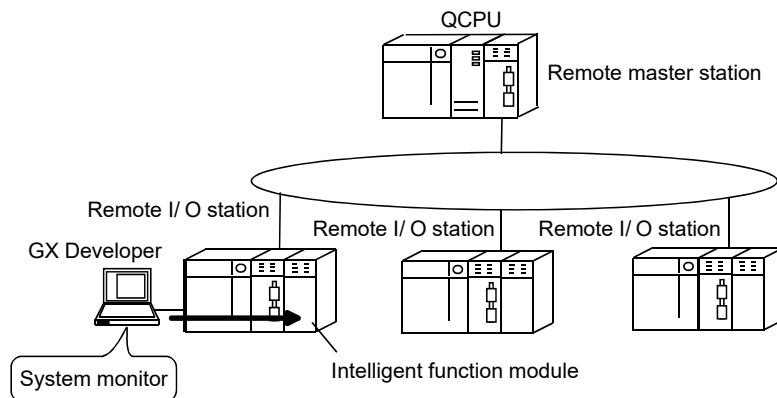

- (2) Connecting GX Developer to the CPU module and perform monitoring via remote master station
Select "Remote I/O" in connection destination PLC type for GX Developer and specify the remote I/O station to be the target in the "Transfer setup" of the "online" menu.

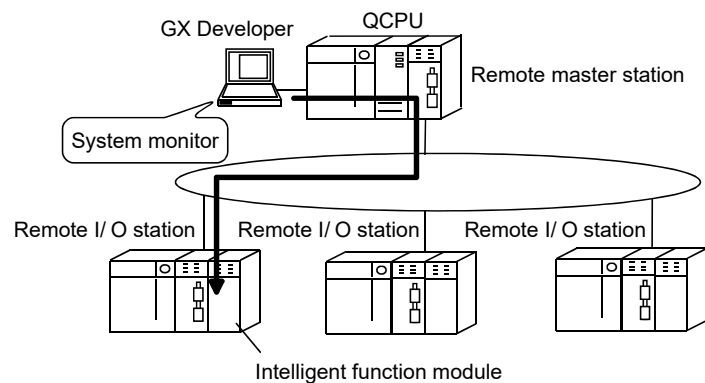

- (3) Connecting GX Developer to another remote I/O module and monitor via the remote I/O network
Select "Remote I/O" in connection destination PLC type for GX Developer and specify the remote I/O station to be the target in the transfer setup of the online menu.

7.3 Device Test for Remote I/O Station

The remote I/O network can use operations of GX Developer connected to the remote I/O station to test the input/output devices of the sequence program without affecting the online system.

To conduct a test without affecting the system, register the device to be tested in "Forced input output registration/cancellation" in "debug" in the online menu. For details about operating the GX Developer, refer to the operating manual for GX Developer.

The test is performed on the following items.

- (1) Stops the Y output from the remote master station to the remote I/O station.

Even when the Y output is set to ON on the sequence program, it is not output from the remote I/O station, allowing output testing of the sequence program to be tested safely. Moreover, if GX Developer is connected directly to the remote I/O module, forced output from GX Developer to the remote I/O module can be performed.

At this time, the X input from the remote I/O station is input to the remote master station.

Common parameters

StationNo.	M station -> R station						M station <- R station					
	Y			Y			X			X		
	Points	Start	End	Points	Start	End	Points	Start	End	Points	Start	End
1	16	1020	102F	16	0020	002F	32	1000	101F	32	0000	001F
2	16	1120	112F	16	0020	002F	32	1100	111F	32	0000	001F

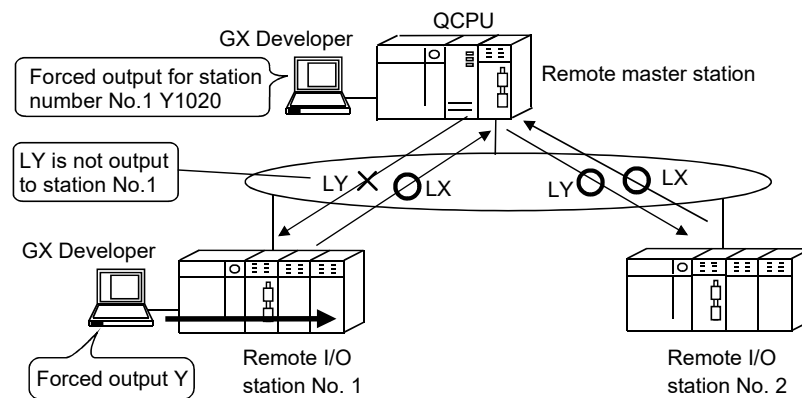

- (2) The remote I/O module stops the X input from the input module
 At this time, the remote I/O station is performing X/Y communication with the remote master station. The remote master station uses GX Developer which is connected directly to the remote I/O module to perform make an X input from GX Developer to the remote I/O station and perform an X input test.

Common parameters

StationNo.	M station -> R station						M station <- R station					
	Y			Y			X			X		
	Points	Start	End	Points	Start	End	Points	Start	End	Points	Start	End
1	16	1020	102F	16	0020	002F	32	1000	101F	32	0000	001F
2	16	1120	112F	16	0020	002F	32	1100	111F	32	0000	001F

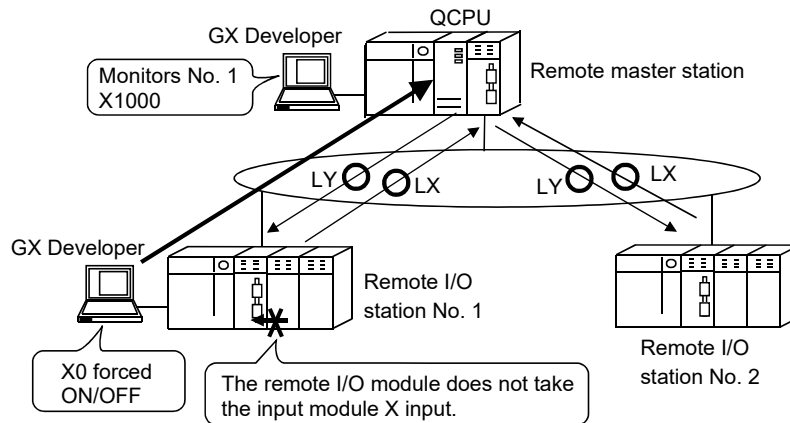

POINT
<p>(1) Always cancel the registration of the forced input/output after the device test has been completed. The REM.LEDs on the remote I/O module for "in device testing" will flash. Once the device testing has been completed, it is possible to check that the REM.LEDs have stopped flashing. If the device test is not cancelled, the remote I/O network could malfunction.</p> <p>(2) After the device has been cancelled, the module operates with data remaining from the device test.</p> <ul style="list-style-type: none"> • When the Y output is on with GX Developer and the device test is cancelled, operation is performed in the Y output on status. • When the X input is on with GX Developer and the device test is cancelled, operation is performed in the X input on status.

7.4 Multiplex Transmission Function (Optical Loop System)

Master	Remote
○	×

The multiplex transmission function allows high-speed communications using duplex transmission paths (both the forward and reverse loops) in the optical loop system. In order to execute the multiplex transmission function, setting for the "Supplementary settings" of the common parameters is required. Note that this setting is not allowed unless the total number of link stations is four stations or more.

- (1) Using the multiplex transmission function, the high-speed communication is performed using both the forward and reverse loops effectively.

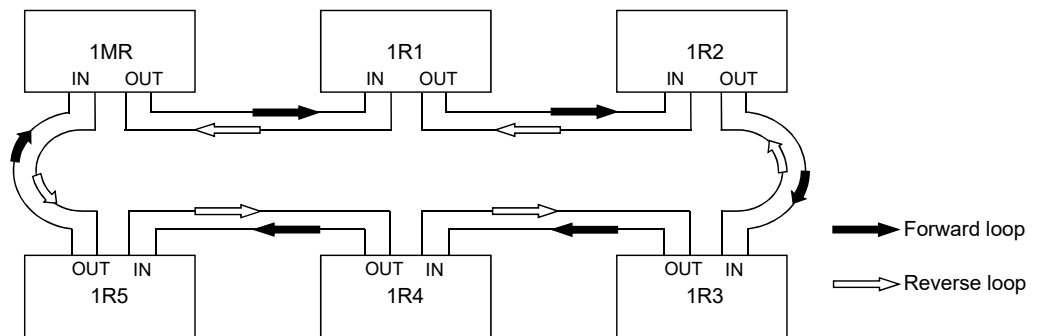

- (2) If an error occurs in the transmission path while the multiplex transmission function is used, data linking continues by communicating only using the transmission path on one side of either the forward or reverse loop, or by switching to the communication using loopback. The transmission speed in this case is 10 Mbps/25Mbps.

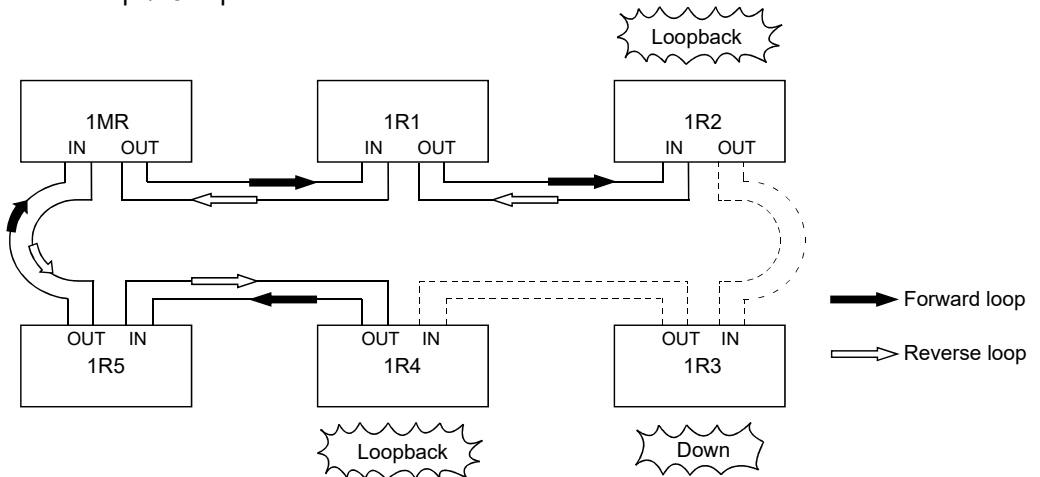

REMARKS

The multiplex transmission function is effective only in reducing the link scan time when the number of connected stations is 16 or more and the link devices assigned with common parameters is 2,048 bytes or more. The link scan time will be 1.1 to 1.3 times faster compared to when the multiplex transmission function is not used. If the multiplex transmission function is used in the configuration where the number of connected stations or the assigned link devices is less than the above, the link scan time may be increased compared to the case where the function is not used.

7.5 Return Sequence Station Number Setting Function

Master	Remote
○	×

The remote I/O net can set the number of stations for which stations with communication errors during one link scan can perform return sequence. If the number of stations set is large, a large number of communication stations with errors can perform return sequence. However, link scan during return sequence will take longer than a normal link scan so care must be taken to lengthen the link scan to match if the setting for return sequence is increased.

(Normally there is no problem using the default settings.)

The maximum number of return sequence stations is set in the supplementary settings for the common parameters.

The setting range is 1 to 64 stations.

The default is set to 2 stations.

7.6 Reserved Station Function

Master	Remote
○	×

The reserved station designation is a function that handles stations to be connected in the future as stations with communication errors. (These stations are not actually connected, but they are included in the total number of stations (remote) in the network.)

Since reserved stations do not affect scan time, full performance can be realized even when they remain reserved.

Reserved stations are set in the common parameters.

7.7 Interrupt Settings

Master	Remote
○	×

The remote master station uses the host interrupt setting parameters to check interrupt conditions at the time data is being received from the remote I/O station. When the interrupt conditions are matched, it issues an interrupt request to CPU module from the master module and starts the interrupt sequence program of the CPU module. Up to 16 interrupt conditions can be set per master module.

[Advantages]

- 1) The startup of the interrupt sequence program of the applicable station can be instructed from remote I/O stations.
- 2) The number of programming steps is reduced and the scan time is shortened because the programming for the startup conditions is not required in the sequence program.

[Visual representation of the function]

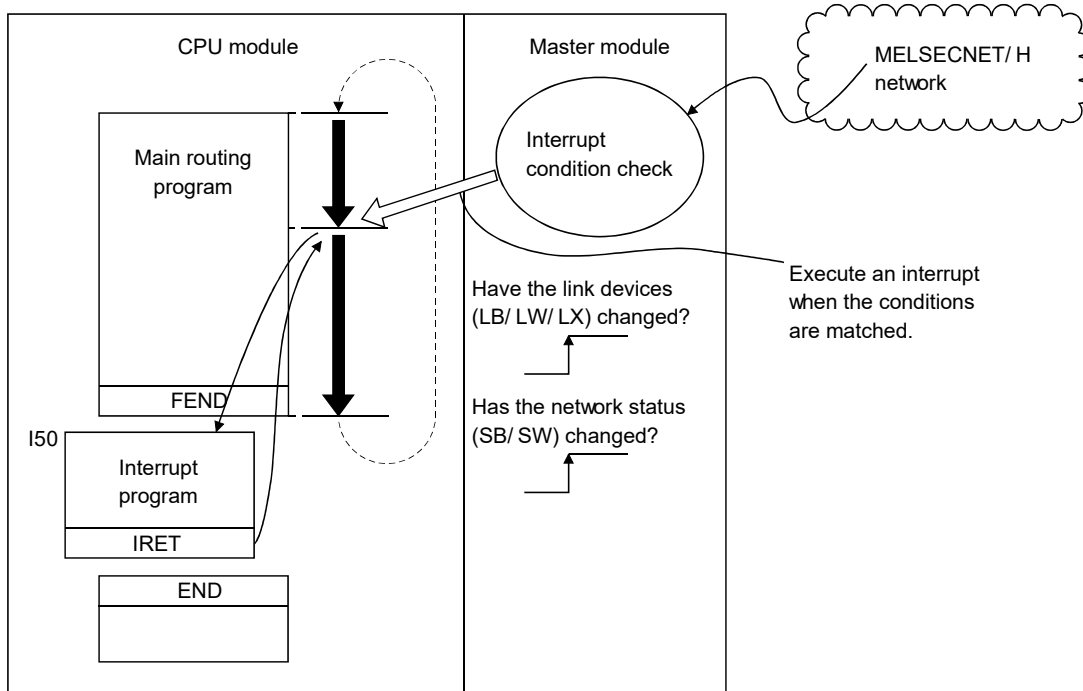

POINT

- When multiple interrupt conditions are set, the operation may be delayed if an interrupt request is issued from other stations at the same time because other interrupts have to wait to be processed.
- When executing the interrupt sequence program, it is necessary to execute "EI" (Enable Interrupt) with the main routine program.

REMARKS

Since the MELSECNET/H does not support the SEND instruction, the device code RECVS instruction cannot be used. For details about interrupt settings, refer to the Q corresponding MELSECNET/H Network System Reference Manual (PLC to PLC network).

7.8 I/O Assignment Function

Master	Remote
×	○

The I/O assignment function is used for the following:

- 1) Reserving points when changing to a module other than 16-point modules
- 2) Preventing I/O number change after module replacement
- 3) Changing I/O numbers to those used in the program
- 4) Setting input response time (I/O response time)
- 5) Setting an output mode for a data link error (Error time output mode setting)
- 6) Setting a remote I/O station operation mode for a hardware error in an intelligent function module (Hardware error time CPU operation mode setting)
- 7) Setting intelligent function module switches

To enable the I/O assignment functions, use GX Developer to set the I/O assignment settings in the PLC parameters for the remote I/O station. The I/O assignments are set within common parameter setting range that has been set in remote master station. As for the I/O assignment settings in the PLC parameters of the remote master station, the I/O assignment within the remote master station are enabled but they are not enabled in the remote I/O station.

Moreover, the I/O assignment of the remote I/O station is only set for remote I/O stations requiring I/O assignment. There is no need to set for all remote I/O stations.

(GX Developer I/O assignment setting screen)

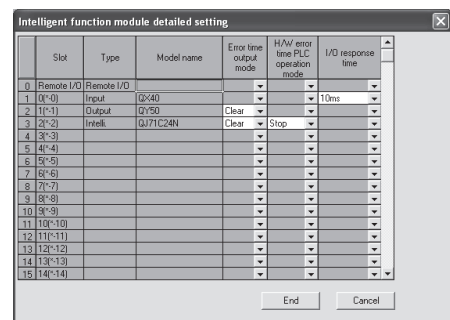
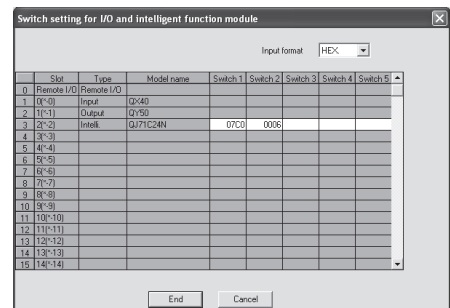
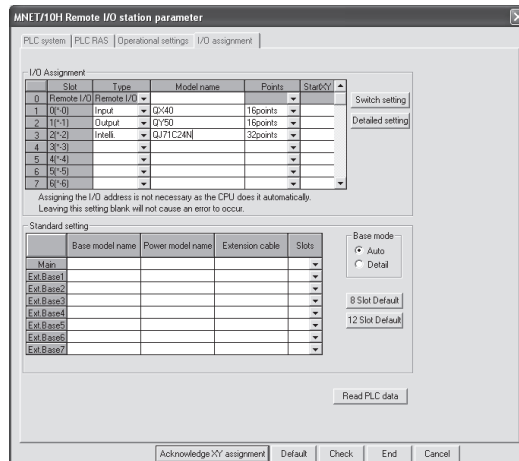

For details about the concepts relating to input/output number assignment and for details about using GX Developer for I/O assignment, refer to the user's manual (Function Explanation, Program Fundamentals) of the CPU module used.

7.9 Stopping/Restarting the Cyclic Transmission and Stopping Link Refreshing (Network Test)

The remote I/O network can use the "network test" of GX Developer to stop and restart cyclic data.

This function is useful when other station's data should not be received or when the host's data should not be sent at system startup (when debugging), etc.

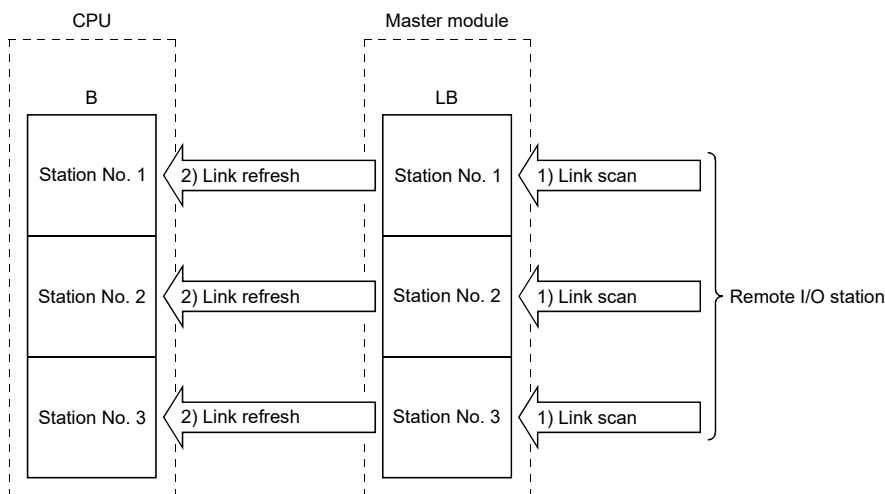

For details about routing, refer to the Q corresponding MELSECNET/H Network System Reference Manual (PLC to PLC network).

- 1) Stopping/restarting the cyclic transmission stops or restarts the data receiving (link scan) between the network modules of the applicable station. However, the data receiving (link refresh) between the programmable controller CPU and master modules cannot be stopped or restarted by this processing.
- 2) Execution using GX Developer
Through the network test, link startup, link stop and forced link startup can be performed using GX Developer. For details on the network testing methods, refer to the GX Developer Operating Manual.

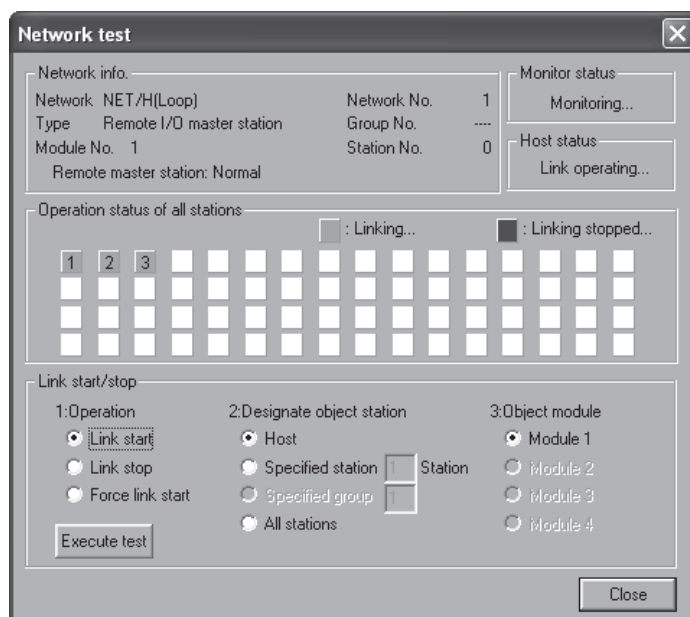

7.10 Multiplexed Remote Master Function (Process CPU)

The multiplex remote master function allows the multiplexed remote sub-master station to take control of the remote I/O stations when the multiplexed remote master station fails.

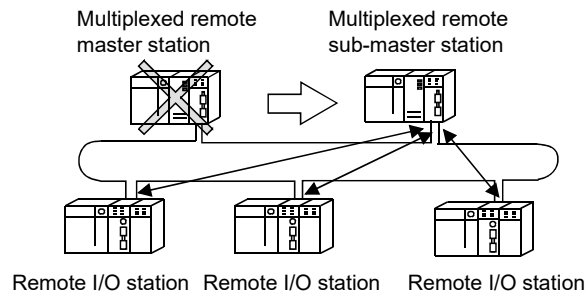

The multiplexed remote master function has the following merits.

Item	Description
(1) Continuation of controlling remote I/O stations when multiplexed remote master station becomes faulty	The multiplexed remote sub-master station (DSM _R) takes control of the remote I/O stations (R), when the multiplexed remote master station (DM _R) becomes faulty.
(2) Selection of operating station status when multiplexed remote master station returns to system	<p>It is possible to set parameter to select the operating station status when the multiplexed remote master station returns to the system.</p> <p>Return to system as control station</p> <p>The master operating station (control station) is switched from the multiplexed remote sub-master station (DSM_R) to the multiplexed remote master station (DM_R).</p> <p>At the time of switching, the remote I/O stations are reset once.</p> <p>Return to system as standby station</p> <p>The multiplexed remote sub-master station (DSM_R) operates continuously as the master operating station (control station).</p> <p>Furthermore, when the multiplexed remote master station has returned to the system as the sub-master operating station (standby station), it is switched to the master operating station (control station) manually.</p>
(3) Startup of a multiplexed remote sub-master station only	By setting the same parameters as the multiplexed remote master station (DM _R), the multiplexed remote sub-master station (DSM _R) can resume control of remote I/O stations if it is powered on and off while controlling the remote I/O stations (in case that the multiplexed remote master station has been faulty).

The following describes each item.

(1) Continuation of controlling remote I/O stations when multiplexed remote master station fails

- (a) By mounting the master modules of the multiplexed remote master station and multiplexed remote sub-master station to different programmable controller CPUs, the multiplexed remote sub-master station automatically controls the remote I/O stations if the multiplexed remote master station fails (switching of master operation).

POINT
The transient transmission executed when the master operation station is switched or returns to the system may be unsuccessfully completed. Execute the transient transmission again if it is unsuccessfully completed.

- (b) Since the sub-master operating station smoothly continues the control of the remote I/O stations when the master operation is switched, it always receives cyclic transmission data (M station ← R station: X, B, W) sent from the remote I/O stations if the master operating station is operating normally.

Also, the sub-master operating station can execute the link dedicated instructions that perform read to the remote I/O stations (REMFR, READ). The link dedicated instructions for performing write (REMTO, WRITE) cannot be executed from the sub-master operating station as the execution from the master operating station has priority. If executed by the sub-master operating station, such instructions result in normal completion without processing (data not written). (An error will not occur.)

REMARKS

When a link dedicated instruction (REMTO or REMFR) for remote I/O stations is executed by mistake between the master station and sub-master station, the execution station shows the following operation status.

Instruction	Execution station	Target station	Operation status of the execution station
REMFR	Master operation station	Sub-master operation station	An error has occurred
	Sub-master operation station	Master operation station	An error has occurred
REMTO	Master operation station	Sub-master operation station	An error has occurred
	Sub-master operation station	Master operation station	Normal end without processing

- (c) To smoothly continue the control of the remote I/O stations when master operation is switched, the data must be always transferred between the multiplexed remote master station and multiplexed remote sub-master station.

Data transfer reflects the condition statuses of outputs from the multiplexed remote master station to remote I/O stations such as the output Y and data output on the remote sub-master station.

Also, data must be transferred from the multiplexed remote sub-master station before the faulty multiplexed remote master station returns to system and switches to master operation.

(Information is transferred by cyclic transmission as performed on a PLC to PLC network.)

- (d) The intelligent function modules such as serial communication module, Ethernet module which are mounted to the remote I/O stations can access the station that is currently performing master operation in the MELSEC communication protocol.

Access Destination	Target Station Number to Be Set
Multiplexed remote master station (Station No. 0)	7DH
Multiplexed remote sub-master station	Multiplexed remote sub-master station No.
Master operating station	7EH

- (e) The outputs of the remote I/O stations are held while master operation is being switched from the multiplexed remote master station to the multiplexed remote sub-master station.

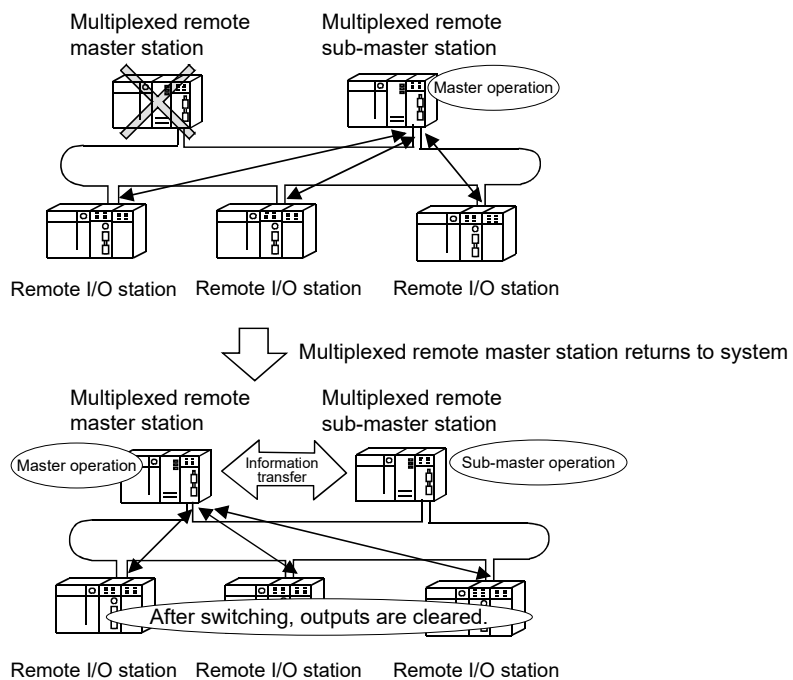

POINT

Start up the multiplexed remote sub-master station last (after the data link of the multiplexed remote master station and remote I/O stations is established).
 To start from a data link using the multiplexed remote master station independently of the startup order, do not set Total stations and Setup common in the parameters of the multiplexed remote sub-master station.

REMARKS

The multiplexed remote master station and multiplexed remote sub-master station cannot be mounted together on a single programmable controller CPU.

- (f) Select the multiplexed remote master station or multiplexed remote sub-master station from "Network type" on the "Module count setting screen" of the GX Developer parameters.

- Multiplexed remote master station:

Module 1	
Network type	MNET /H[Multiplexed remote master]

- Multiplexed remote sub-master station:

Module 1	
Network type	MNET /H[Multiplexed remote sub]

Since the multiplexed remote master station needs to recognize the station number of the multiplexed remote sub-master station, set the station number of the multiplexed remote sub-master station on the network range assignment screen of the multiplexed remote master station.

1) Choose station No. of multiplexed remote sub-master station.

The screenshot shows the 'Setup common parameters and I/O assignments' dialog box. At the top, there are settings for 'Assignment method' (Points/Start selected), 'Monitoring time' (200 x 10ms), 'Parameter name', 'Total slave stations', and 'Switch screens' (BW setting). Below this is a table with columns for 'StationNo.' and four 'M station' configurations (B, W, B, W). The 'StationNo.' column has a dropdown menu currently showing 'Sub 1'. An arrow points to this dropdown with the text '1) Choose station No. of multiplexed remote sub-master station.' At the bottom of the dialog, there are several buttons: 'Specify reserved station', 'Remote sub-master station', 'Equal assignment', 'Supplementary setting', 'Clear', 'Check', 'End', and 'Cancel'. The 'Remote sub-master station' button is highlighted with a box and an arrow pointing to it with the text '2) After choosing station No. of multiplexed remote sub-master station, click this button to complete setting. After the setting is completed, "Sub" appears in Station No. field.'

- 2) After choosing station No. of multiplexed remote sub-master station, click this button to complete setting. After the setting is completed, "Sub" appears in Station No. field.

- (g) On the network range assignment screen, assign the ranges for information transfer to/from the multiplexed remote sub-master station and also the ranges for control of the remote I/O stations.

(2) Selection of operating station status when multiplexed remote master station returns to system

It is possible to set the parameter of the multiplexed remote master station to select whether the remote I/O stations will be controlled by the multiplexed remote master station or by the multiplexed remote sub-master station when the multiplexed remote master station returns to system while the remote I/O stations are being controlled by the multiplexed remote sub-master station.

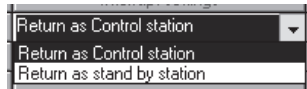

POINT
 The transient transmission executed when the master operation station is switched or returns to the system may be unsuccessfully completed. Execute the transient transmission again if it is unsuccessfully completed.

(a) Return to system as control station:

The multiplexed remote master station returns to the system as the master operating station (control station).
 The multiplexed remote master station controls the remote I/O stations. The multiplexed remote sub-master station shifts to sub-master operation.
 After switching, the outputs of the remote I/O stations are cleared.

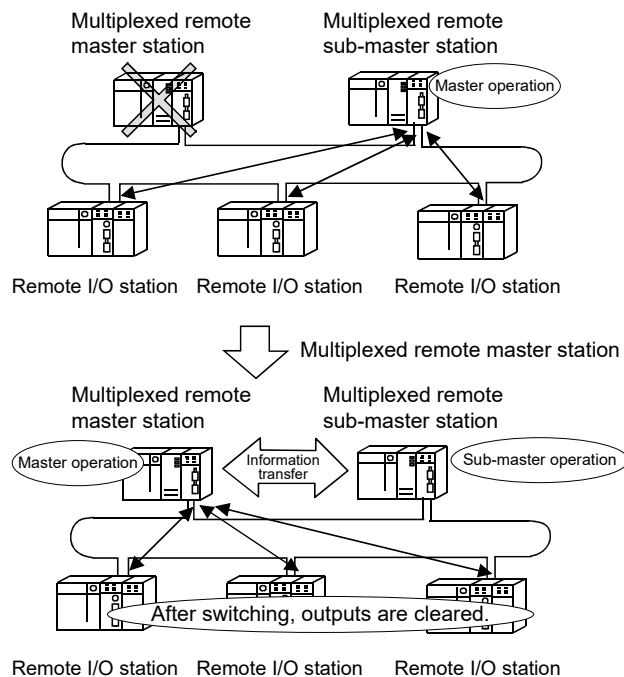

- (b) Return to system as standby station:
 The multiplexed remote master station returns to the system as the sub-master operating station (standby station).
 The multiplexed remote sub-master station continues the control of the remote I/O stations.

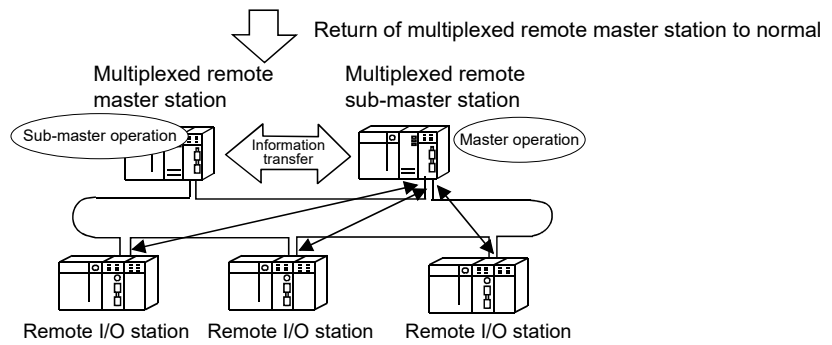
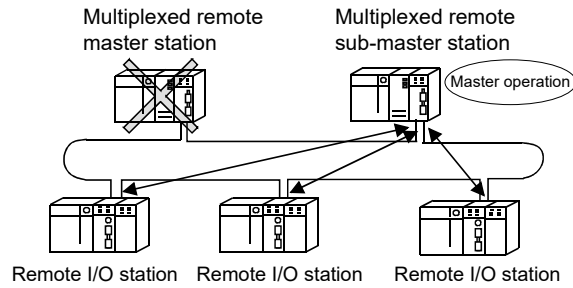

- (c) Switching of multiplexed remote master station operation
- When the multiplexed remote master station has returned to system, it can be switched to master operation in the following procedure.
- 1) The multiplexed remote sub-master confirms that the multiplexed remote master station has returned to the system by checking the link special relay (SB) status.
 - 2) The multiplexed remote sub-master station switches from master operation to sub-master operation by operating the link special relay (SB).
 - 3) The multiplexed remote master station switches to master operation when the multiplexed remote sub-master station switches to sub-master operation.

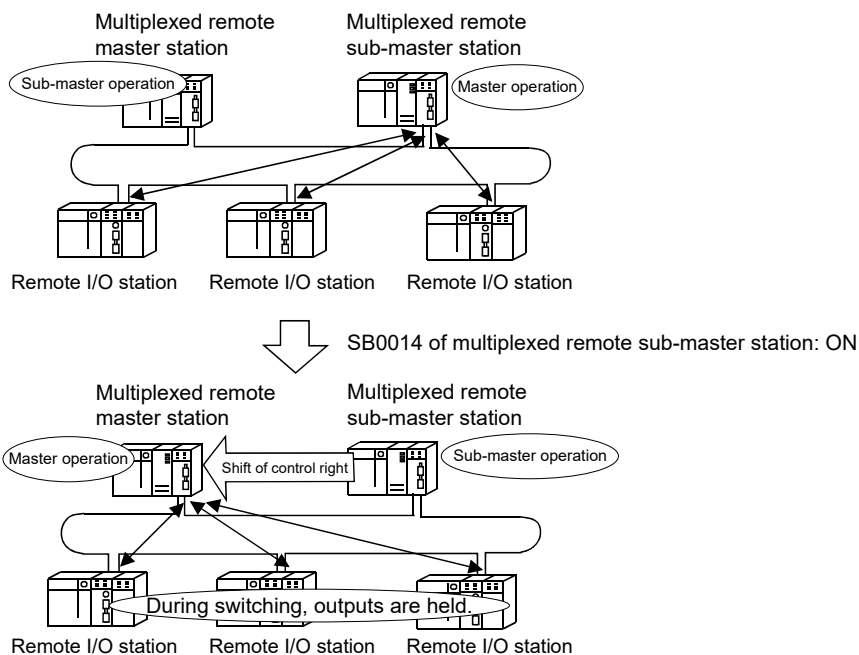

The link special relays used to confirm operating status of multiplexed remote master station

Number	Name	Description
SB0071	Remote master station baton pass status	Indicates the baton pass status of the master station. OFF : Master station baton pass normal ON : Master station baton pass abnormal
SB0075	Remote master station cyclic transmission status	Indicates the cyclic transmission status of the master station. OFF : Master station cyclic transmission normal ON : Master station cyclic transmission abnormal

The link special relays used to switch multiplexed remote sub-master station operation

Number	Name	Description
SB0014	Remote sub-master station switching command	Forcibly directs the remote sub-master station that is performing master operation to shift to sub-master operation (invalid for redundant systems). OFF : Without directive ON : With directive
SB01C4	Remote sub-master station switching acceptance status	Indicates the status of accepting the directive to shift from master operation to sub-master operation. OFF : Without acceptance ON : With acceptance
SB01C5	Remote sub-master station switching status	Indicates the operation status of a shift from master operation to sub-master operation. OFF : Without shift ON : Shift completion

Program example

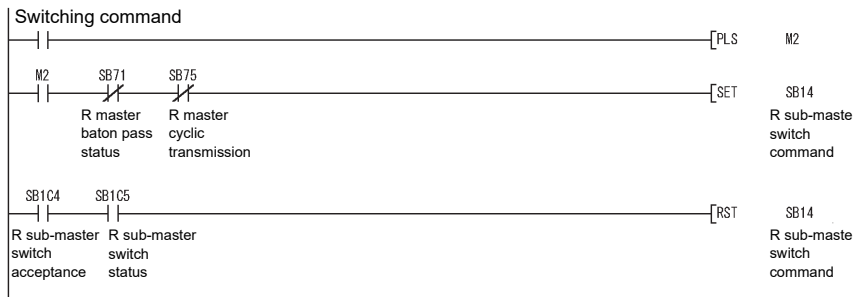

(3) Startup of a multiplexed remote sub-master station only

- (a) By setting the same parameters as the multiplexed remote master station, the multiplexed remote sub-master station continues the control of the remote I/O stations if it is powered on and off while controlling the remote I/O stations.

However, the outputs of the remote I/O stations are cleared when the multiplexed remote sub-master stations resumes the controls.

POINT
 Except items "Network type" and "Starting I/O No.", set the parameter of the multiplexed remote sub-master station same as the multiplexed remote master station.

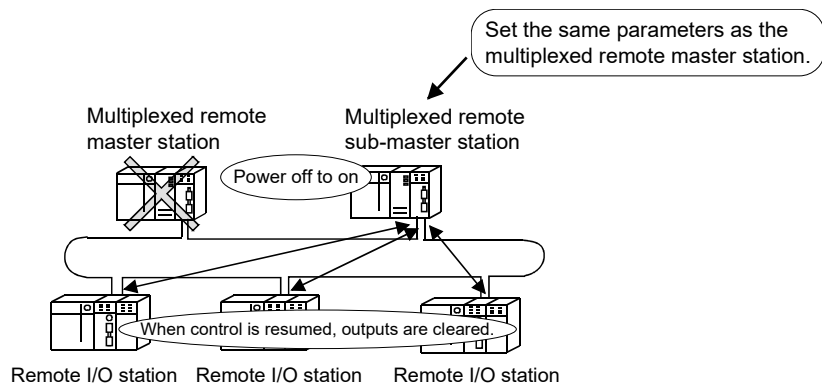

REMARKS

If the multiplexed remote master station has returned to the system and performs sub-master operation, the multiplexed remote master station controls the remote I/O stations.

- (b) This function enables the remote I/O stations to be controlled by the multiplexed remote sub-master station alone if the multiplexed remote master station is not made ready at a system startup.

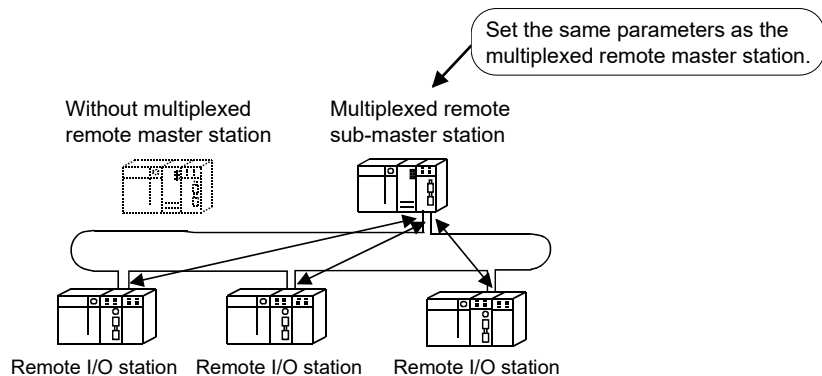

- (4) Communication among multiplexed remote master station, multiplexed remote sub-master station and remote I/O stations
- (a) The input (X) data of the remote I/O station and the link relay (B) and link register (W) data sent by the remote I/O station are transferred to both the multiplexed remote master station and multiplexed remote sub-master station.
 - (b) The output (Y) data of the remote I/O station and the link relay (B) and link register (W) data received by the remote I/O station are normally controlled by the multiplexed remote master station. When the multiplexed remote master station fails, the multiplexed remote sub-master station controls the data.
 - (c) Between the multiplexed remote master station and multiplexed remote sub-master station, data are transferred using X/Y/B/W to ensure that the multiplexed remote sub-master station can control the remote I/O station continuously when the multiplexed remote master station fails.

• LX/LY data flow between stations

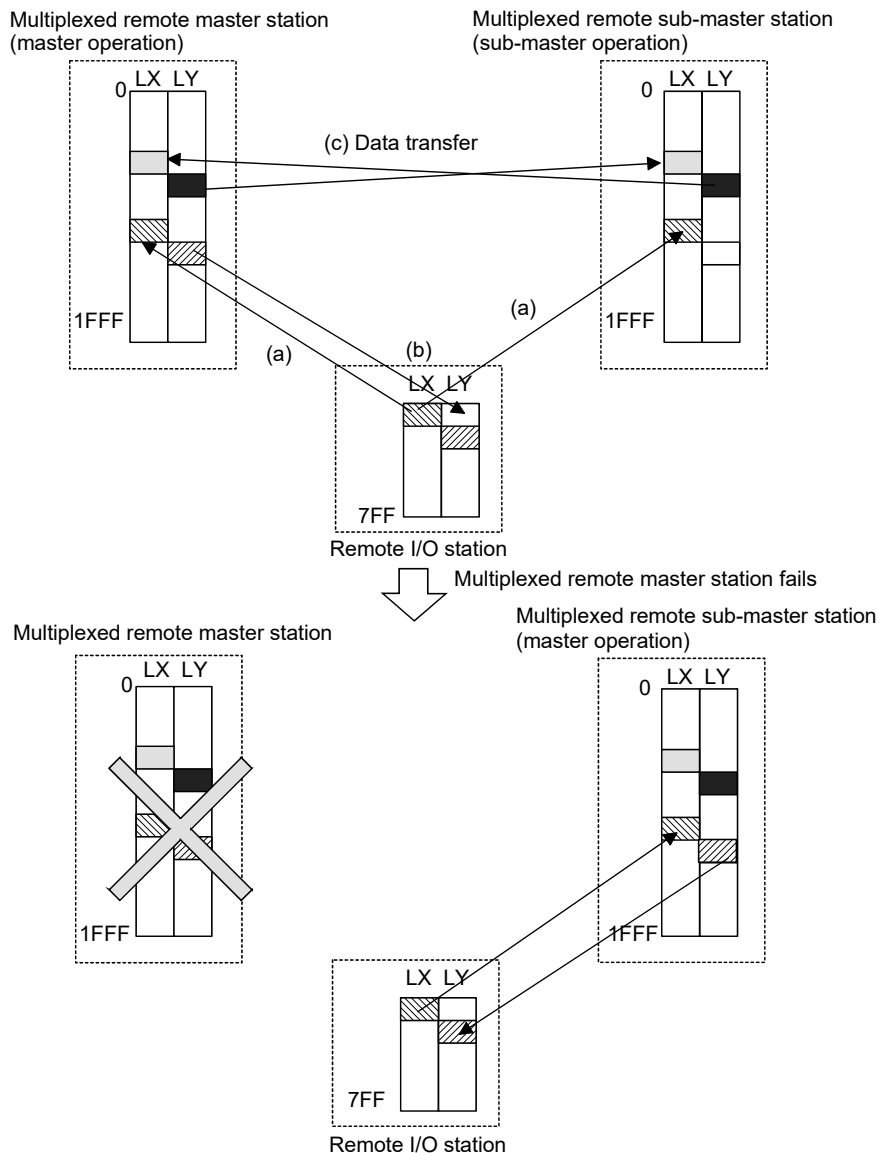

• LB/LW data flow between stations

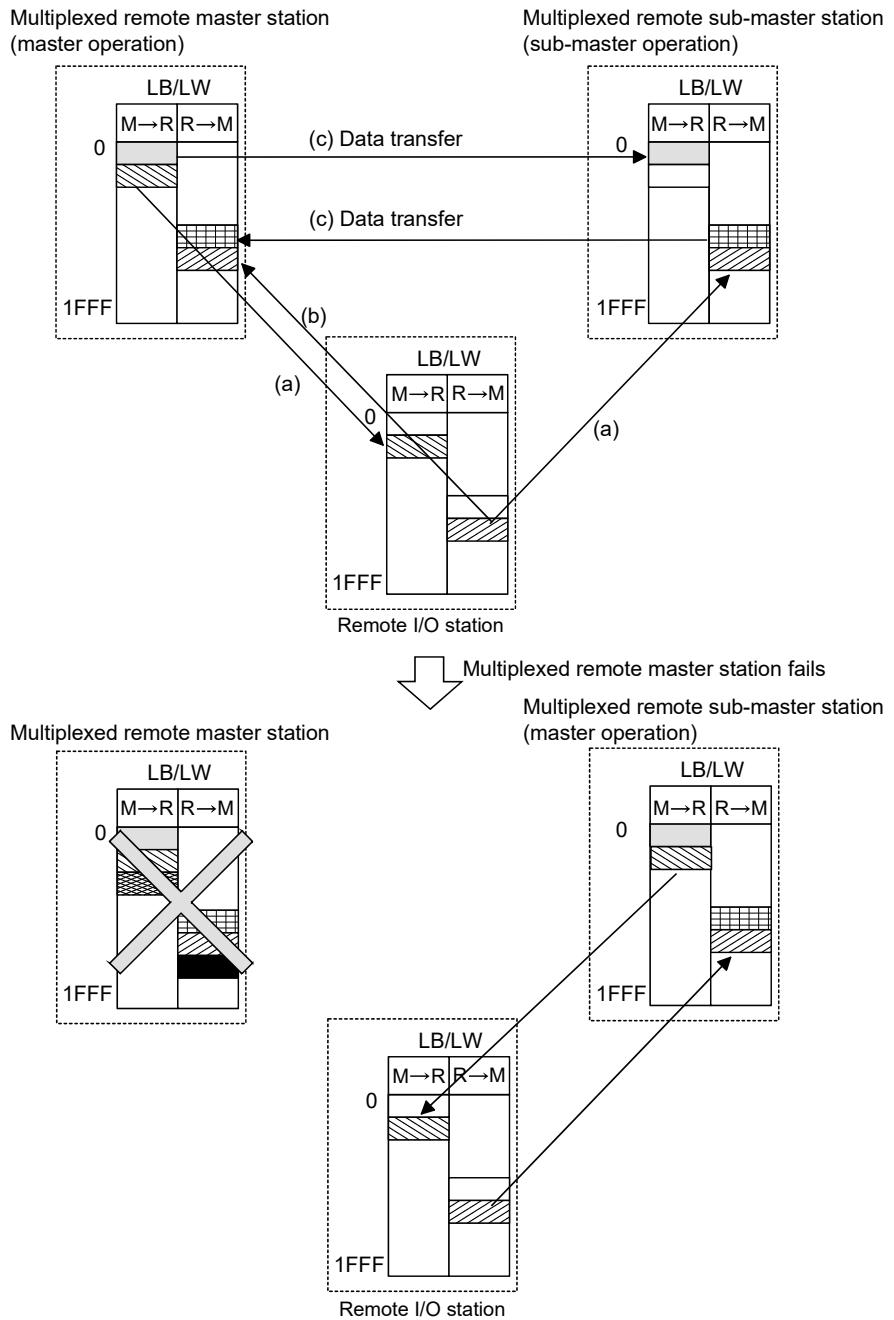

- (5) Discrimination using the indicator LEDs of a multiplexed remote master station and a multiplexed remote sub-master station
 It is possible to confirm either of the multiplexed remote master station or multiplexed remote sub-master station is controlling the remote I/O stations by ON/OFF status of the MNG LED on the corresponding station.

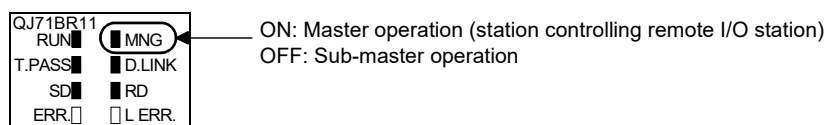

(6) Program example to transfer data between a multiplexed remote master station and a multiplexed remote sub-master station

The following program example assumes that the same program is used on the multiplexed remote master station and multiplexed remote sub-master station to transfer data between the multiplexed remote master station and multiplexed remote sub-master station.

(a) System configuration

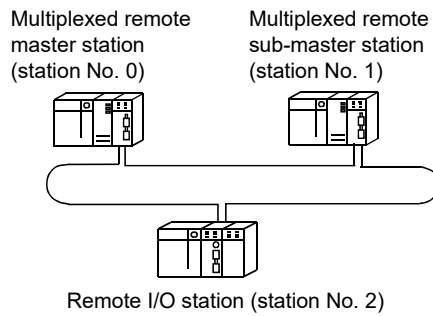

(b) LB and LW range assignment

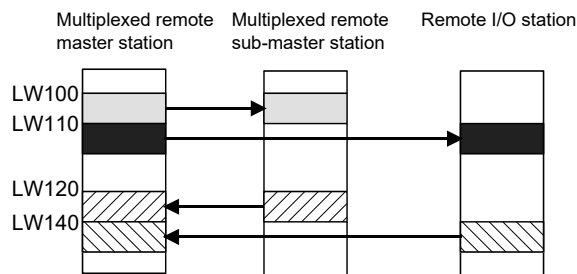
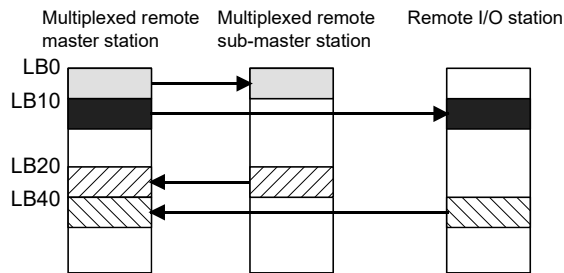

(c) Purpose of using the LB/LW for data transfer between a multiplexed remote master station and a multiplexed remote sub-master station

The LB/LW for data transfer transfers from the multiplexed remote master station to the multiplexed remote sub-master station the data that are needed to switch remote I/O station control from the multiplexed remote master station to the multiplexed remote sub-master station.

- (d) Link special relay and link special registers used to make the programs identical

The following link special relay and link special registers can be used to check the send/receive device ranges of the multiplexed remote master station and multiplexed remote sub-master station.

Number	Name	Description
SB01CB	Send/receive device number valid/invalid status	Indicates whether the send/receive device numbers (SW01C8 to SW01CF) of the remote sub-master station are valid or invalid. OFF : Invalid ON : Valid
SW01CC	Send LB device number	For the remote master station: The send LB device number to the remote sub-master station is stored. For the remote sub-master station: The send LB device number to the remote master station is stored.
SW01CD	Receive LB device number	For the remote master station: The receive LB device number from the remote sub-master station is stored. For the remote sub-master station: The receive LB device number from the remote master station is stored.
SW01CE	Send LW device number	For the remote master station: The send LW device number to the remote sub-master station is stored. For the remote sub-master station: The send LW device number to the remote master station is stored.
SW01CF	Receive LW device number	For the remote master station: The receive LW device number from the remote sub-master station is stored. For the remote sub-master station: The receive LW device number from the remote master station is stored.

The SW01CC to SW01CF values are valid only when SB01C8 is ON.

In this example, the following values are stored into the corresponding link special registers.

Target Station	SW01CC	SW01CD	SW01CE	SW01CF
Multiplexed remote master station	0	20	100	120
Multiplexed remote sub-master station	20	0	120	100

Using the above values, the multiplexed remote master station and multiplexed remote sub-master station can confirm the starting addresses of the LB/LW devices sent/received by themselves.

(e) Program example: For multiplexed remote master station

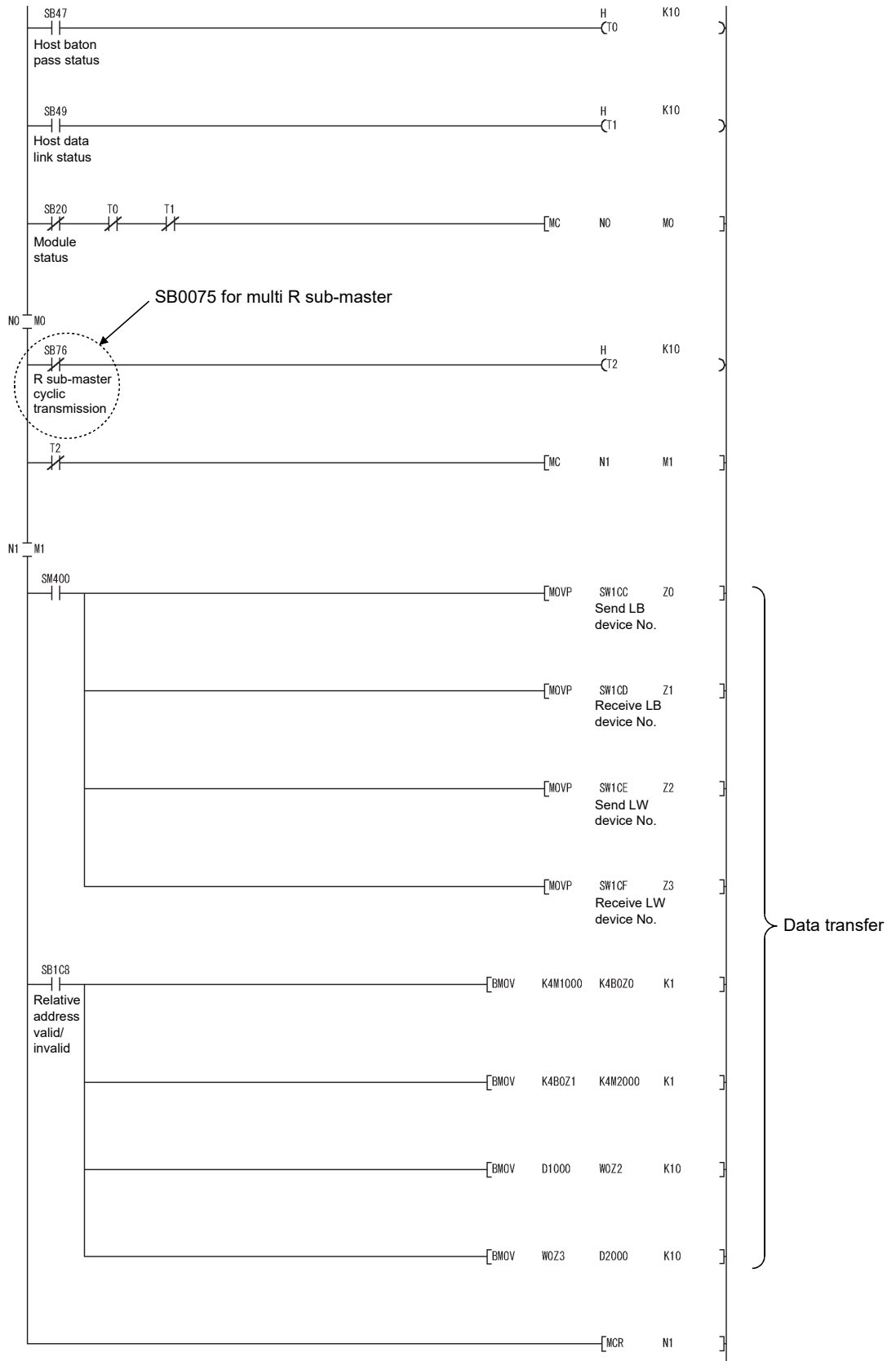

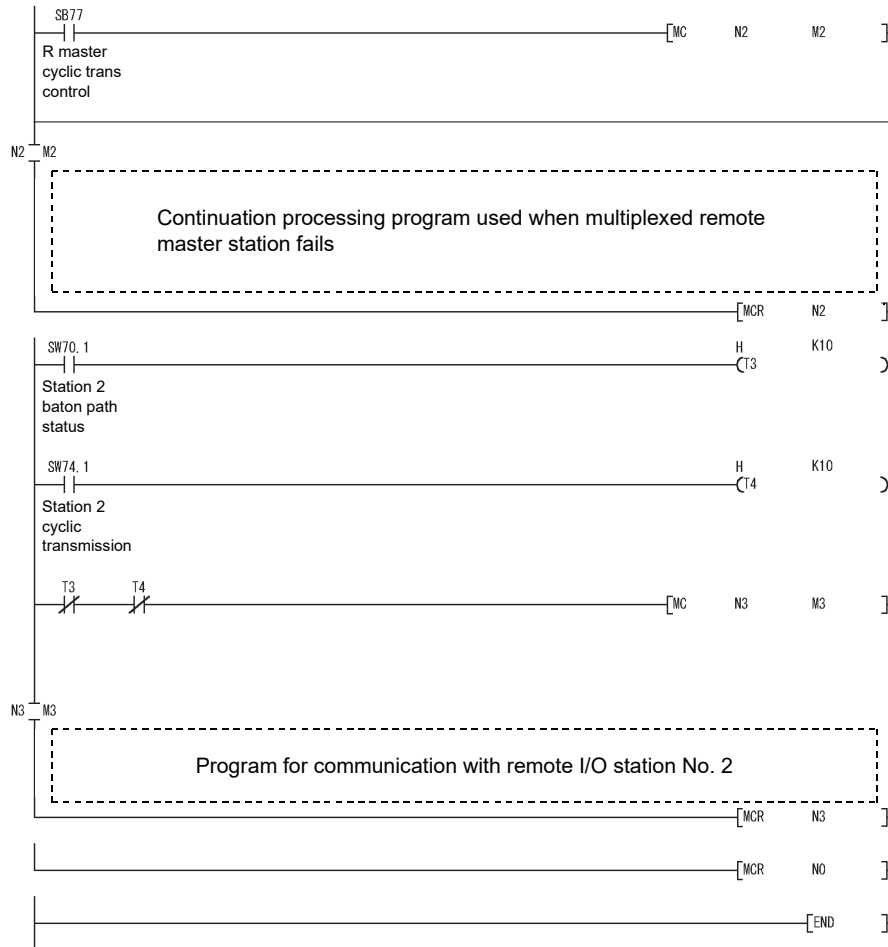

In the timer constant K , set the following value.

Baton path status (T0, T3)	(Sequence scan time × 4) or more
Cyclic transmission status Parameter communication status (T1, T2, T4)	(Sequence scan time × 3) or more

Reason: The above value should be set to prevent control from being stopped if the network has detected an instantaneous fault due to the cable, noise and so forth.

4 times and 3 times are given as guidelines.

7.11 Multiplexed Remote Master Function for the Redundant System (Redundant CPU)

The redundant system uses the multiplexed remote master function to control I/O modules and intelligent function modules.

The multiplexed remote master function for the redundant system continues the control of remote I/O stations when the multiplexed remote master station (control system) fails by switching the multiplexed remote master station from the control system to the standby system and switching the multiplexed remote sub-master station (standby system) from the standby system to the control system.

The multiplexed remote sub-master station (control system) which is controlling a remote I/O station continues the control of the remote I/O station even after the multiplexed remote master station (standby system) returns to the normal status.

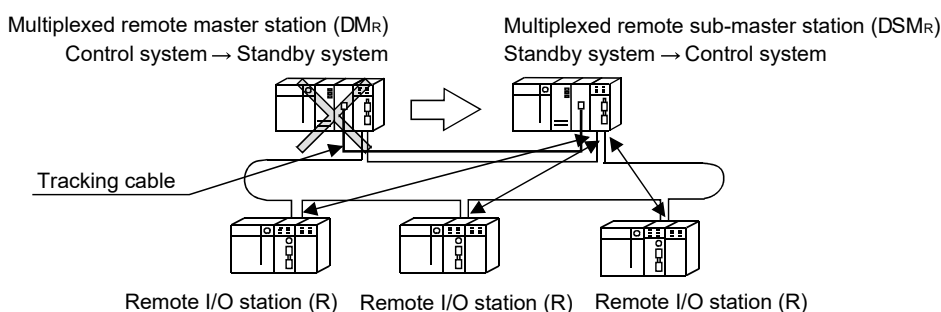

The multiplexed remote master function for the redundant system includes the following features.

Item	Description	Reference section
(1) Backup function of master operation on system switching between control system and standby system	When a power supply error or CPU error occurs in the control system, the Redundant CPU in the standby system continues the operation of the redundant system by switching to the control system. With the system switching, the multiplexed remote sub-master station switched from the standby system to the control system takes over master operation to continue the control of remote I/O stations.	Section 7.11.1
(2) Master operation by the station that has started up as the control system	The master module mounted with the Redundant CPU that has started up as the control system operates as the master station. The master module mounted with the CPU that has started up as the standby system operates as the sub-master station.	Section 7.11.2
(3) System switching request function of control system	The master module mounted in the control system CPU issues the system switching request to the control system CPU when a data link error such as link cable disconnection or transmission error are detected.	Section 7.11.3
(4) Access function by specifying control system or standby system	Access from GX Developer or others to Redundant CPU can be performed by specifying the control system/standby system instead of station No. Therefore, the control system can be accessed any time even if system is switched.	Section 7.11.4

(1) Network parameter settings

It is not required to create each project for control system/standby system. In a redundant system, parameters and sequence programs common to both systems can be created in one project.

(2) Station No. settings

For the master module mounted on the station (multiplexed remote master station) to which the system A connector of tracking cable is connected, set the station No.0.

If the station No. other than 0 is set, the programmable controller CPU will detect the LINK PARA. ERROR (error code 3101).

For the master module mounted on the station (multiplexed remote sub-master station) to which system B connector of tracking cable is connected, set the station No. in the range of 1 to 64. If the station No. 0 is set, the programmable controller CPU will detect the LINK PARA. ERROR (error code 3101).

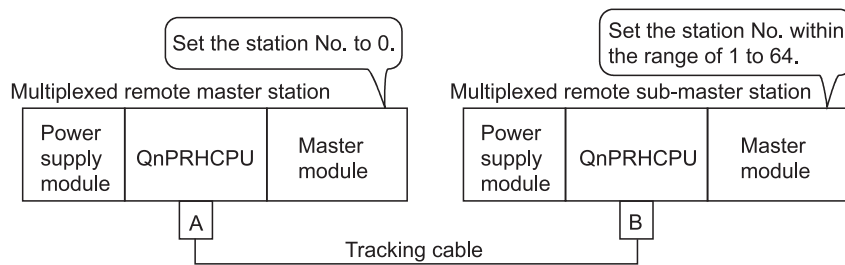

7.11.1 Backup function of master operation on system switching between control system and standby system

- (a) The redundant system consists of a control system (multiplexed remote master station) and standby system (multiplexed remote sub-master station) of the same system configuration. If a power supply error or CPU error occurs in the control system, the Redundant system switches the standby system to the control system to continue the operation of the redundant system.

With the system switching, the master module mounted in the multiplexed remote master station of the new standby system stops master operation and the multiplexed remote sub-master station of the new control system takes over the master operation to continue the control of remote I/O stations.

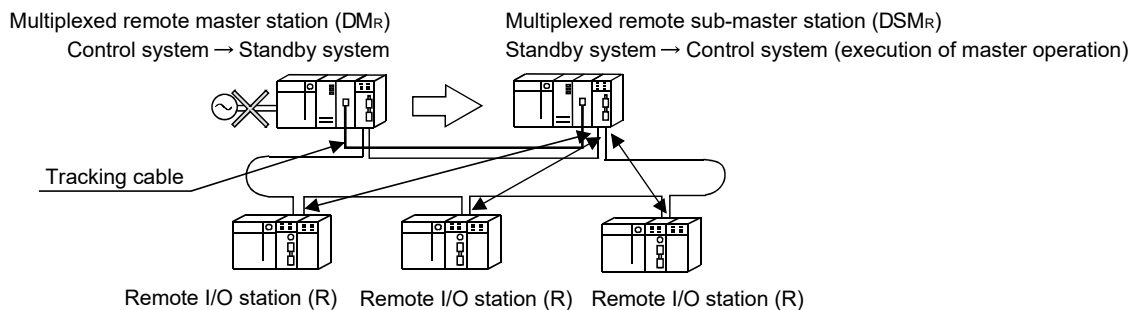

POINT

The transient transmission executed when the master operation station is switched or returns to the system may be unsuccessfully completed. Execute the transient transmission again if it is unsuccessfully completed.

- (b) The sub-master station always receives the cyclic transmission data (remote I/O station to master station: X, B, and W) sent by remote I/O stations even while the master station operates normally in order to continue the control of the remote I/O stations smoothly when master operation is switched.
- (c) The multiplexed remote master station and multiplexed remote sub-master station always transfer data to each other through a tracking cable (tracking) in order to continue the control of remote I/O stations smoothly when master operation is switched.

POINT

When tracking the link special relay and link special register, do not transfer the link special relays (SB0020 to SB01FF) and link special registers (SW0020 to SW01FF) used by the system.

- (d) The output of the remote I/O station is held while master operation is switched from the multiplexed remote master station to the multiplexed remote sub-master station.

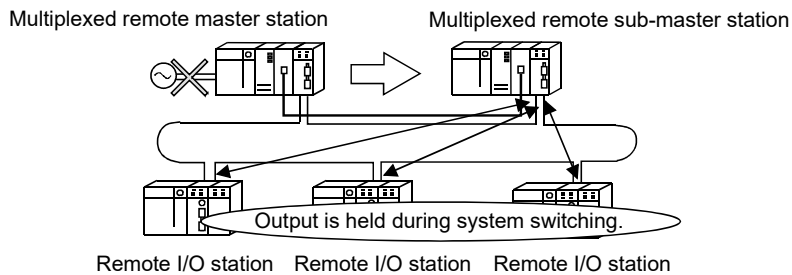

- (e) If the multiplexed remote master station returns to the normal status while the multiplexed remote sub-master station controls remote I/O stations, the multiplexed remote master station will perform sub-master operation as the standby system.

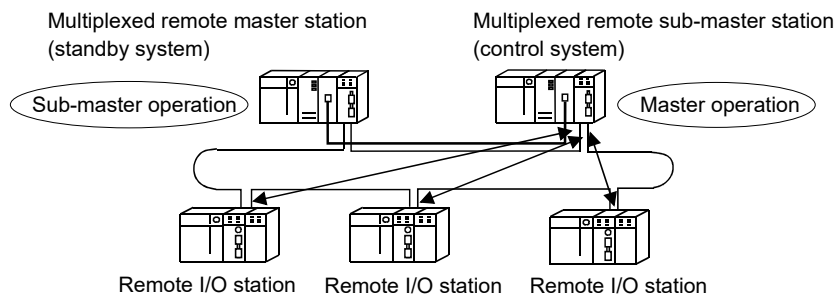

7.11.2 Master operation by the station that has started up as the control system

The master module mounted in the station that has started up as the control system performs master operation. The master module mounted in the standby system station performs sub-master operation.

REMARKS

For the determination of the control system or standby system, refer to the QnPRHCPU User's Manual (Redundant System).

Which of the multiplexed remote master station or multiplexed remote sub-master station are controlling remote I/O stations can be checked from the MNG LED of each station.

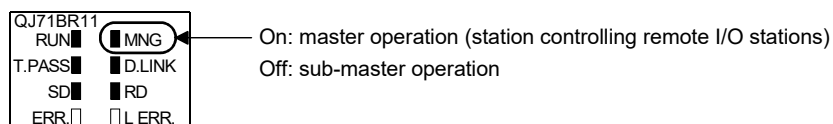

7.11.3 System switching request function of control system

The control system includes the system switching request function, i.e., the master module mounted in the control system CPU issues the system switching request to the control system CPU when it detects the data link error such as link cable disconnection or communication error. This function enables the standby system to continue the control even when the master module of the control system goes down.

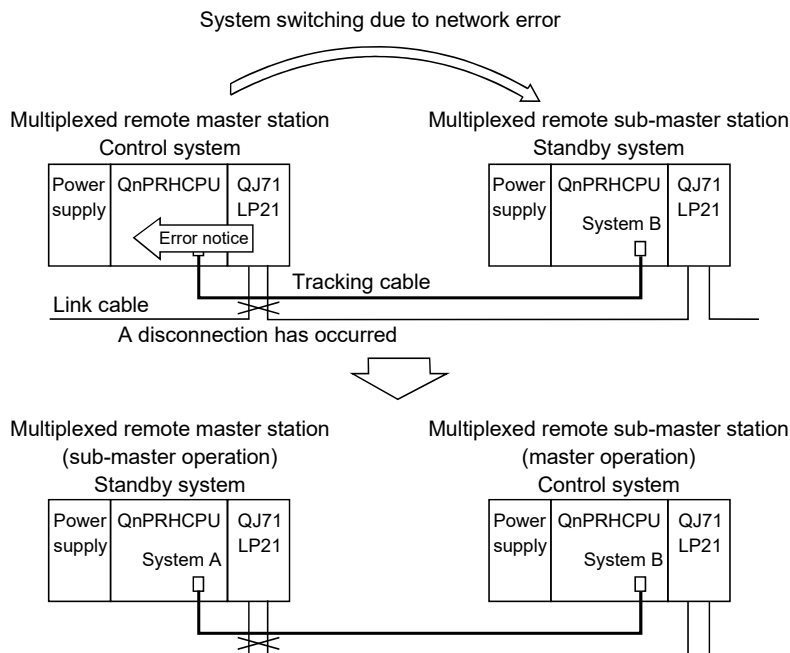

However, if the CPU of the control system cannot perform system switching due to the standby system error, only the master operation of the master module shifts to the master module of the standby system (multiplexed remote sub-master station). In this case, since the CPU of the standby system cannot process the sequence program, the CPU controls the network only. (Various modules mounted in remote I/O stations cannot be controlled.)

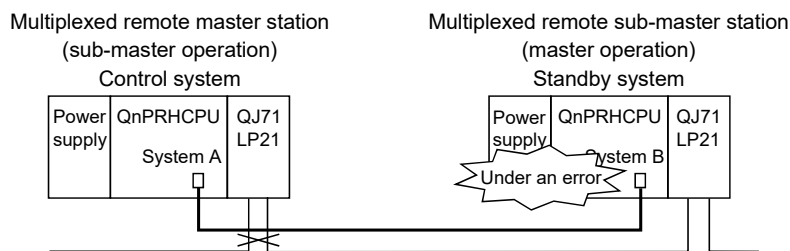

POINT

The following must be performed before operating the system

- Powering ON/OFF of other stations (including those on the standby system)

If the above operation is performed during system operation, a MELSECNET/H module on the control system may detect a communication error and a system-switching request may be issued.

When the system-switching request is issued before startup of the standby system, a continue error, "CAN'T SWITCH" may be detected in the control system CPU.

Generally, normal system control is continued even if "CAN'T SWITCH" is detected.

However, in the case of the system where error detection will stop the control, program the system to prevent such a control stop.

For the method for automatically clearing the "CAN'T SWITCH" error, refer to the QnPRHCPU User's Manual (Redundant System).

REMARKS

For the details of system switching, refer to QnPRHCPU User's Manual (Redundant System).

The master module issues a system switching request when the status of data link is changed from "under data link" to "data link halted" (when the D.LINK LED of the master module turns off).

Although the time interval from when the data link is stopped to when the system switching request is issued to the control system CPU is set to two seconds, the interval can be changed using the link special relay (SB) and link special register (SW).

Link special relay and link special register used for setting a system switching monitoring time

Number	Name	Description
SB0018	Switching monitoring time setting enable flag	Indicates whether the switching monitoring time setting is enabled or disabled. OFF : The switching monitoring time setting (SW0018) is disabled. ON : The switching monitoring time setting (SW0018) is enabled.
SW0018	Switching monitoring time setting	Set a time from the detection of a data link halt to issue of system switching request in the redundant system. 0: 2s (default) 1 to 500: in 10ms (set up in 10ms units within the range of 10ms to 5s.)

To reduce the system switching time from 2s to 0.5s, set SB0018/SW0018 in the sequence program as follows.

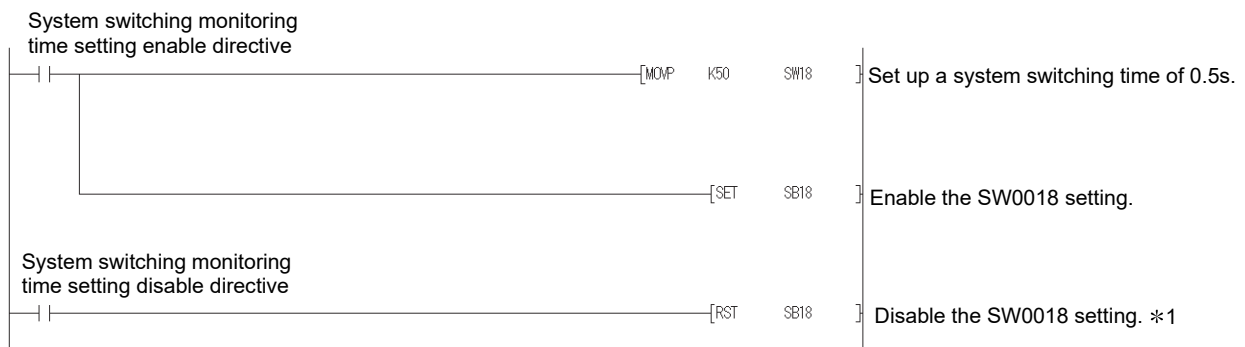

*1: If SB0018 is disabled (OFF), the system switching monitoring time is 2s (default).

POINT

The master module issues the system switching request to the control system CPU even when the data link error is caused by the following accident: the master module mounted in the control system is not connected with a cable or disconnected at the time of power ON.
The master module issues the system switching request within 4s after power ON.

7.11.4 Access function by specifying the control system or standby system

This function is for making access to the Redundant system by specifying the control system or standby system using GX Developer or other methods. By using this function, access to the control system is enabled even after system switching occurs due to error.

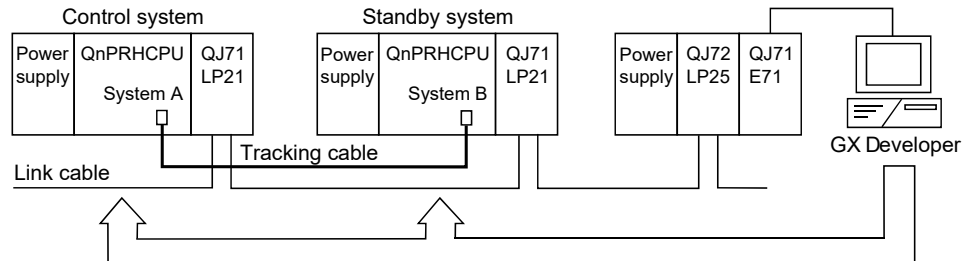

QnPRHCPU can be accessed by specifying either the control system or standby system

The settings on the request source (GX Developer) are as follows.

Specify the control system, standby system, system A, or system B on the connection setup screen in the online menu.

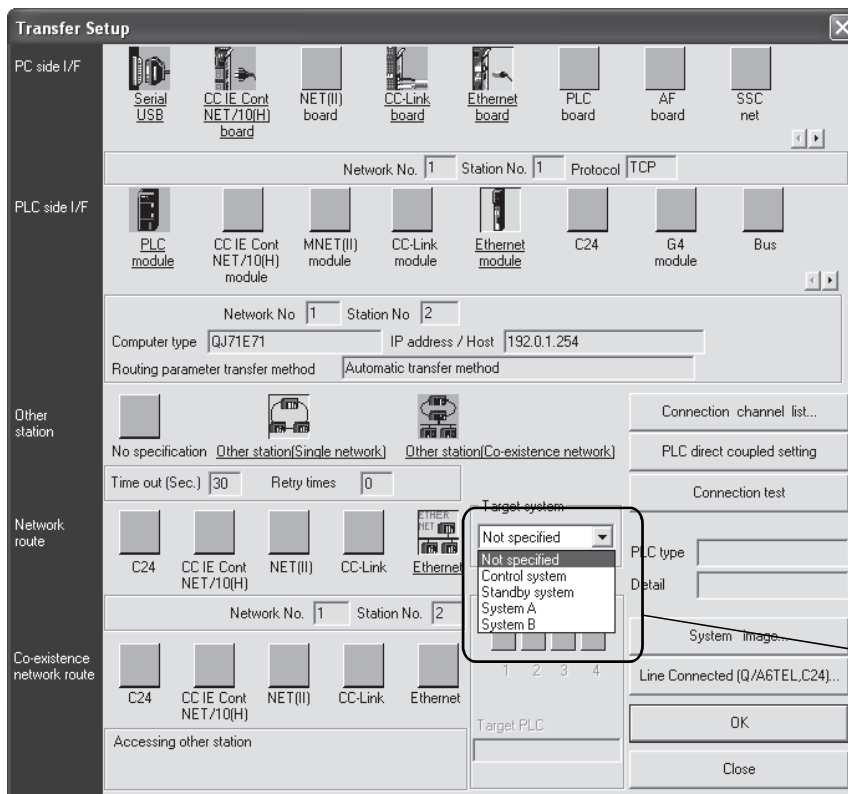

REMARKS

For the details of the GX Developer operation, refer to the operation manual of GX Developer.

7.12 Remote password

The remote password function is the function for preventing a remote user from illegally connecting to a remote I/O module and programmable controller CPU. The remote password function can be used by setting a remote password for a remote I/O module.

If a remote password has been set up, the serial communication module and Ethernet module check the remote password when a connection request is issued from a remote user to a remote I/O module and programmable controller CPU.

REMARKS

The remote password set for the programmable controller CPU of the remote master station does not affect the remote passwords of the remote I/O stations.

(1) Setting, changing and cancelling a remote password

(a) Setting a remote password

Set a remote password on the remote password setting screen of GX Developer. Write the remote password to be set by connecting GX Developer with the target remote I/O module directly.

The remote I/O module transfers the remote password to the specified serial communication module and Ethernet module when the system is powered on or the remote I/O module is reset.

(b) Changing and Cancelling the remote password

By connecting GX Developer with a remote I/O module, the remote password of the connected remote I/O module can be changed and cancelled.

The remote password can be changed by setting a new remote password by GX Developer and writing it into the remote I/O module.

The remote password can be canceled by deleting it by GX Developer and writing it into the remote I/O module.

The figure below shows the outline of setting, changing, and canceling a remote password with the Ethernet module.

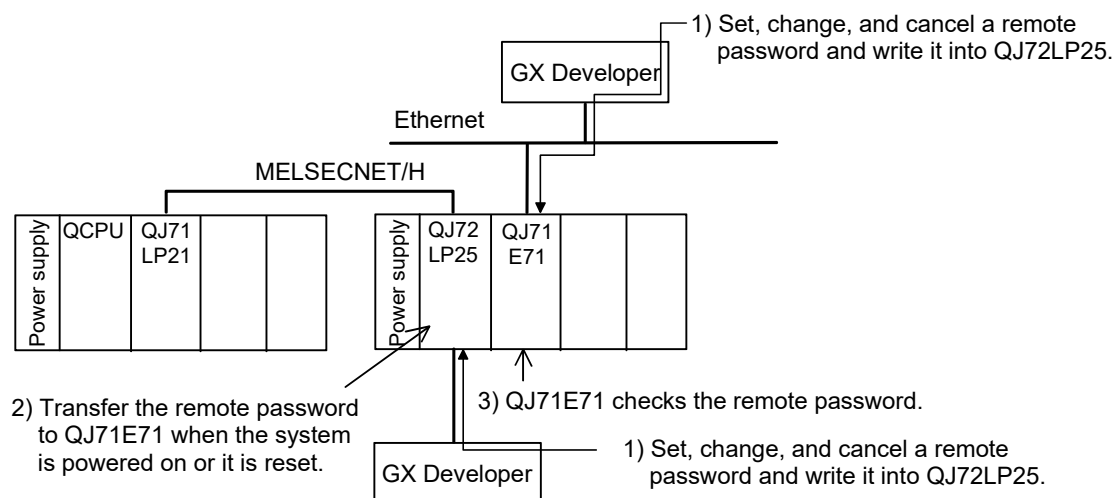

(2) Unlocking and locking the remote password

The remote password is unlocked (connection is allowed) via the modem by the serial communication module or via Ethernet by the Ethernet module. When the remote password is matched, connection to the remote I/O module is allowed.

The figure below shows the outline of unlocking and locking (connection is allowed) a remote password with the Ethernet module.

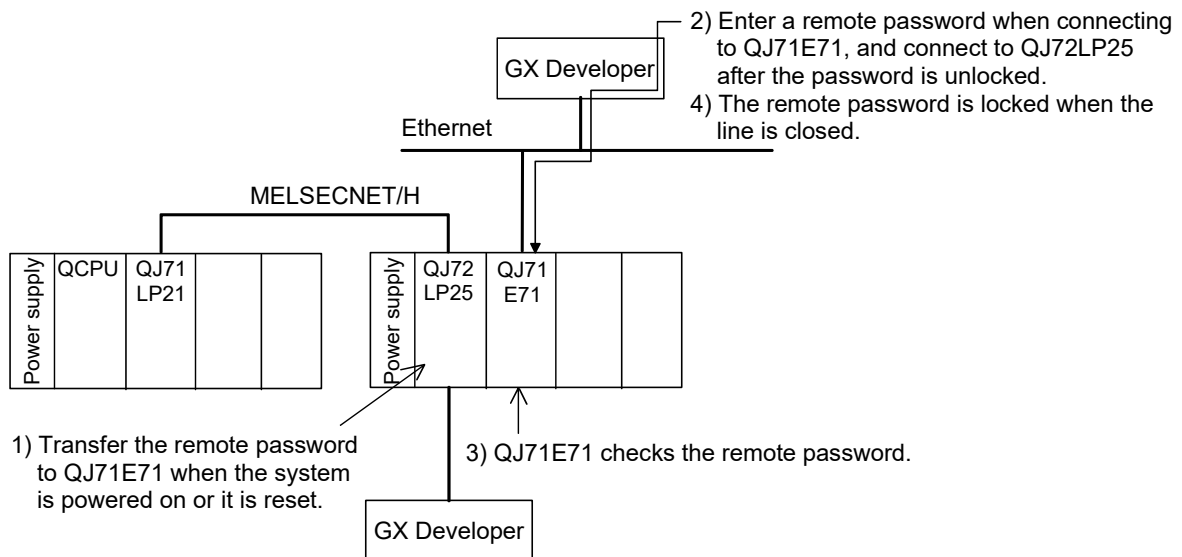

(3) Number of modules for that can be set to check remote passwords

The table below lists the number of modules that can be set to check remote passwords.

Module name	Max. number of modules	Max. number of modules in the system
Ethernet module	4	8
Serial communication module	8	

(4) Setting procedure of remote password

"GX Developer" → "Remote pass" → "Remote password settings" screen → "Remote password detail settings" screen

(a) Setting screen

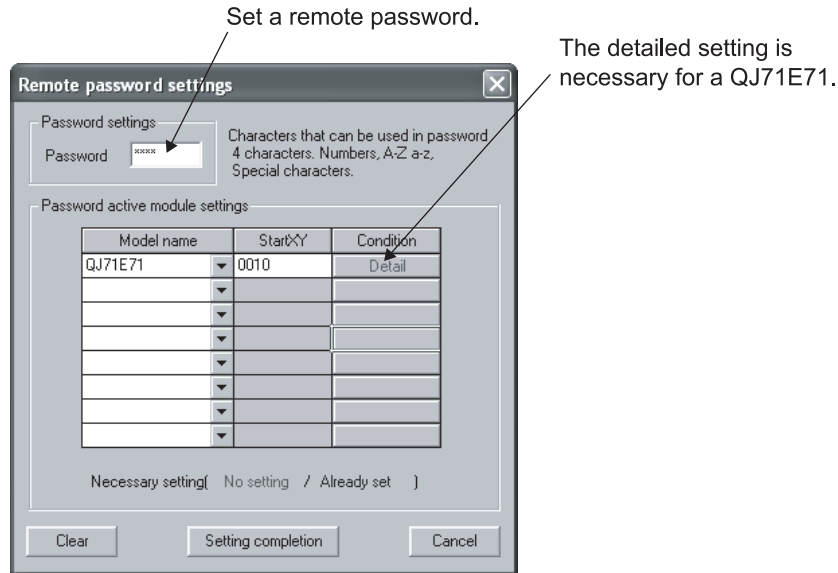

(b) Setting items

Item		Setting	Setting range/option
Password settings		Enter a remote password	4 characters, ASCII code *1
Password active module settings	Model name	Select a model	QJ71E71/QJ71C24/QJ71CMO
	Start XY	Set the module's top address.	0000H to 0FE0H
Detail		—	Available or N/A
User connection No.		Set a connection No. for users	Connection No.1 to 16
System connection	Auto open UDP port	Check the remote password valid port	—
	FTP transmission port (TCP/IP)		
	GX Developer transmission port (TCP/IP)		
	GX Developer transmission port (UDP/IP)		
	HTTP port		

*1: Indicates the upper/lower-case characters (other than " ", i.e., space) that can be input using the keyboard

POINT
<p>For the details of the remote password function, refer to the manuals below.</p> <ul style="list-style-type: none"> • When the serial communication module is used: Q Corresponding Serial Communication Module User's Manual (Application) • When the Ethernet module is used: Q Corresponding Ethernet Interface Module User's Manual (Basic)

(5) Error codes detected by remote I/O module

Error code	Error message	LED status	Description	Measures
3400	REMOTE PASS. ERR.	ERR. LED: on	The head I/O number of the target module in the remote password file is set to other than 0H to 0FF0H.	Change the head I/O number of the target module to within the 0H to 0FF0H range.
3401	REMOTE PASS. ERR.	ERR. LED: on	Any of the following modules is not mounted on the slot specified for the head I/O number of the remote password. <ul style="list-style-type: none"> • Serial communication module of function version B or later • Ethernet module of function version B or later 	Mount any of the following modules in the position specified for the head I/O number of the remote password. <ul style="list-style-type: none"> • Serial communication module of function version B or later • Ethernet module of function version B or later

(6) Cautions when setting a remote password

- (a) If the starting I/O No. is changed after the remote password is set, the previous remote password set with the Ethernet module/serial communication module becomes invalid.
- (b) Only the remote password set for the directly connected module can be canceled (unlocked) by remote operation of GX Developer. (The remote password for the indirectly connected module cannot be canceled by remote operation.)

8 TROUBLESHOOTING

In order to ensure high system reliability, it is important to take precautions before the system is operated and to quickly and effectively correct problems if they do occur. This is why it is important to perform off-line testing of the network and checking of the cables when first starting the system.

Make sure to perform the following checks, which are explained in Chapter 4, "Setup and Procedures Before Starting the Operation."

- 1) Standalone operation check and operational setting of the network module
- 2) Offline tests:
Hardware test, Internal self-loopback test, self-loopback test and forward loop/reverse loop test.
- 3) Check the connection of the data link cable.
Network diagnostic loop test (requires optical system)

Even with this, if an error does occur, it is important to quickly and accurately understand the nature of the problem. The following are three methods for confirming the contents of an error.

(1) Network diagnostics to remote master station with GX Developer

(a) Network monitor (refer to Section 8.1)

The status of the following four types of networks can be checked by monitoring the line:

- 1) Status of the entire network: Host information
- 2) Data link status and parameter status, etc. of each station:
Other station information
- 3) Control station information, detailed data link information, etc.:
Network monitor details
- 4) Loop switch count, line error, communication error, etc.:
Error history monitor

(b) Diagnostic tests (refer to Sections 4.10)

The following four items can be checked or executed through the diagnostic tests:

- 1) Wiring status (IN/OUT, etc.) of the data link cable:
Loop test (required for optical loop system)
- 2) Setting status of numbers: whether the same station number has been set for two or more stations, whether two or more control stations/remote master stations exist, network numbers, and group numbers: Setup confirmation test
- 3) The order of stations connected in the direction of the forward loop and the reverse loop: Station order check test
- 4) Setting status of the routing parameters: Communication test

(2) Confirmation by error code: Refer to Section 8.3

When either cyclic transmission or transient transmission using link dedicated instructions or GX Developer (communication with other stations) was not normally performed, an error code is stored in the link special register and the system monitor.

The contents of the error can be checked using this error code.

(3) Confirmation by the LEDs on the front of the network module (Refer to Section 4.2)

With the LED displays, the following errors can be checked: whether the host is operating or stopped, whether the station acts as a control station or a normal station, whether the baton pass is being executed, whether data linking is being executed, whether data are being transmitted/received, and whether any error has occurred.

(4) Confirmation of the error history of the entire system (Refer to Section 8.3)

By using GX Works2, the error history of the entire system can be checked even after errors were cleared by turning on and off the programmable controller or by resetting the programmable controller CPU.

8.1 Network Diagnostics (Network Monitor)

The status of the remote I/O network can be checked using the network diagnostic function of GX Developer.

When an error occurs, the faulty station can be identified using the host station information, another station information, and error history monitor functions of the network.

GX Developer network diagnosis can be implemented for the remote master station and remote I/O station *1.

*1: Use GX Developer Version 6.01B or later when executing network diagnosis from the remote I/O station.

The following lists the items that can be checked with the network diagnostic function.

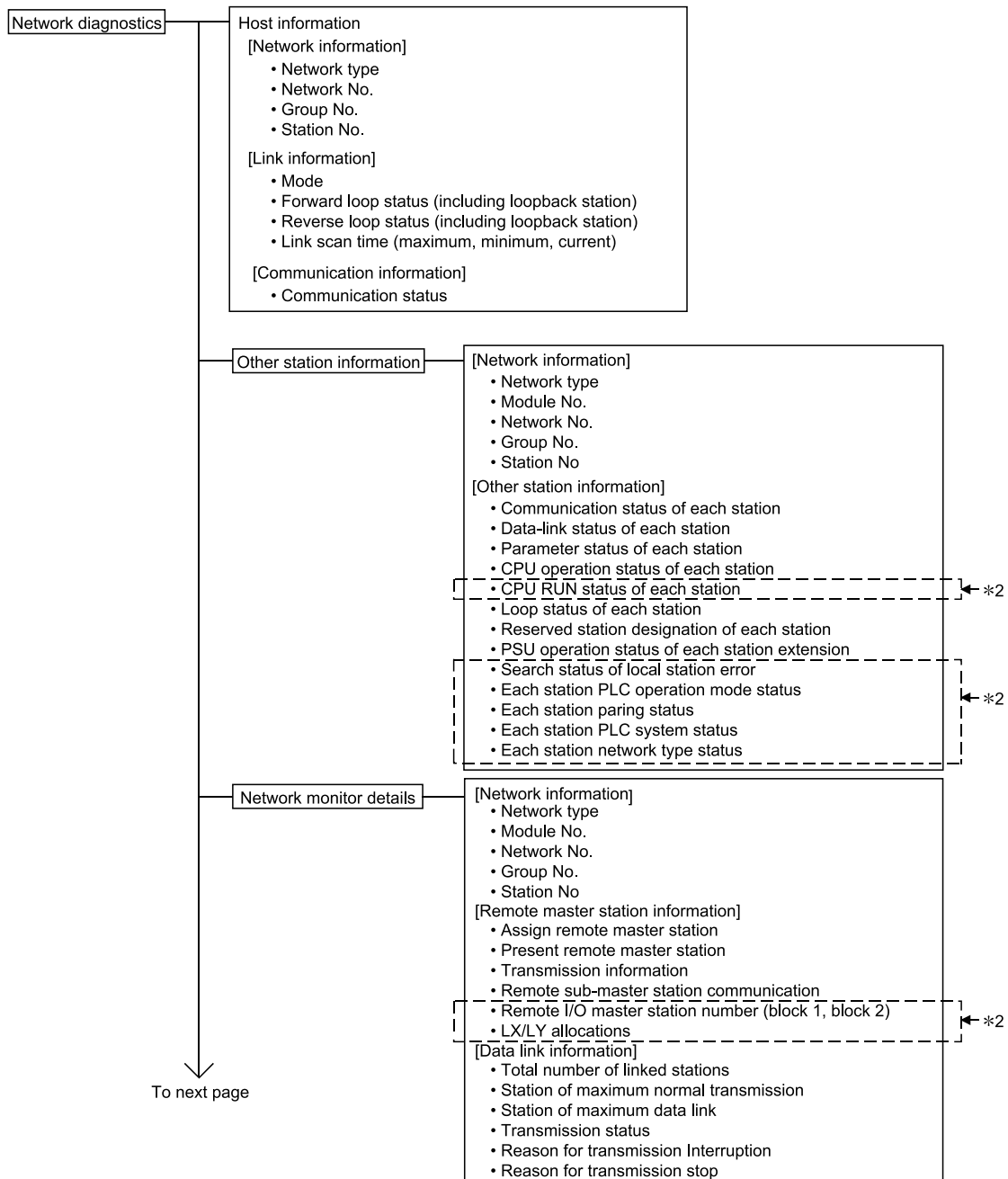

To next page

* 2: When PLC to PLC network is diagnosed, this information is effective.

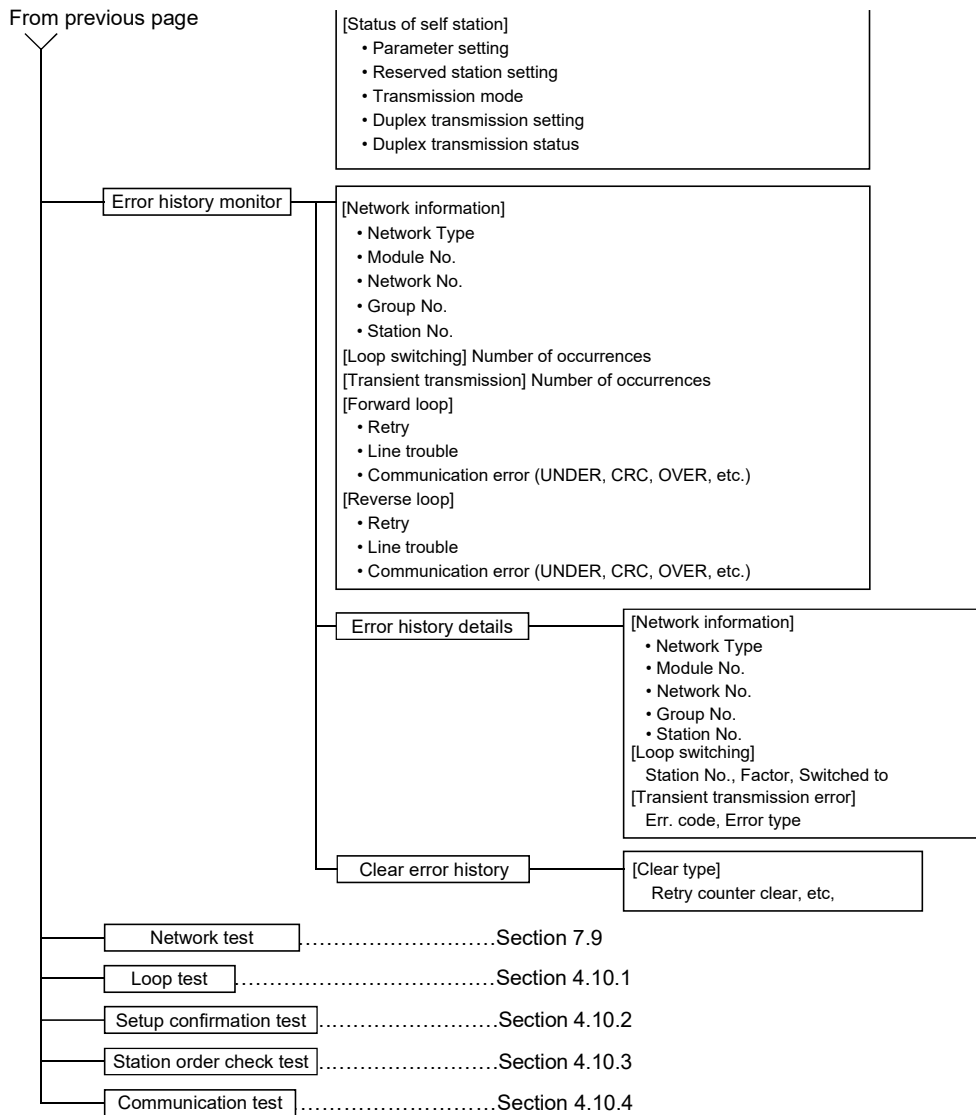

POINT
<p>(1) The target of the network diagnostics is the host's network designated as the connection destination.</p> <p>(2) If the connection target is specified as another station or the redundant CPU is specified as a control system, standby system, system A, or system B, the network monitor can check only the information of the host and other stations.</p> <p>(3) The network diagnostics cannot be displayed correctly while the network module is executing the offline test.</p> <p>(4) When the link dedicated instruction is used to access the other station programmable controller during network diagnosis, the execution of the link dedicated instruction may be delayed.</p> <p>After taking the following measures, perform network diagnosis processing and execute the link dedicated instruction.</p> <ul style="list-style-type: none"> • Execute the COM instruction. • Secure the communication processing security time for 2 to 3ms. For the High Performance model QCPU, Process CPU, and Redundant CPU, set it by the special register SD315. For the Universal model QCPU, set it by the service processing setting of the PLC parameter (PLC system) of GX Developer.

REMARKS

SB□□□□ and SW□□□□ found in the explanations of each item indicate the link special relay (SB) or the link special register (SW) used for monitoring.

8.1.1 Host information

The information of the entire network and the status of the host station can be checked.

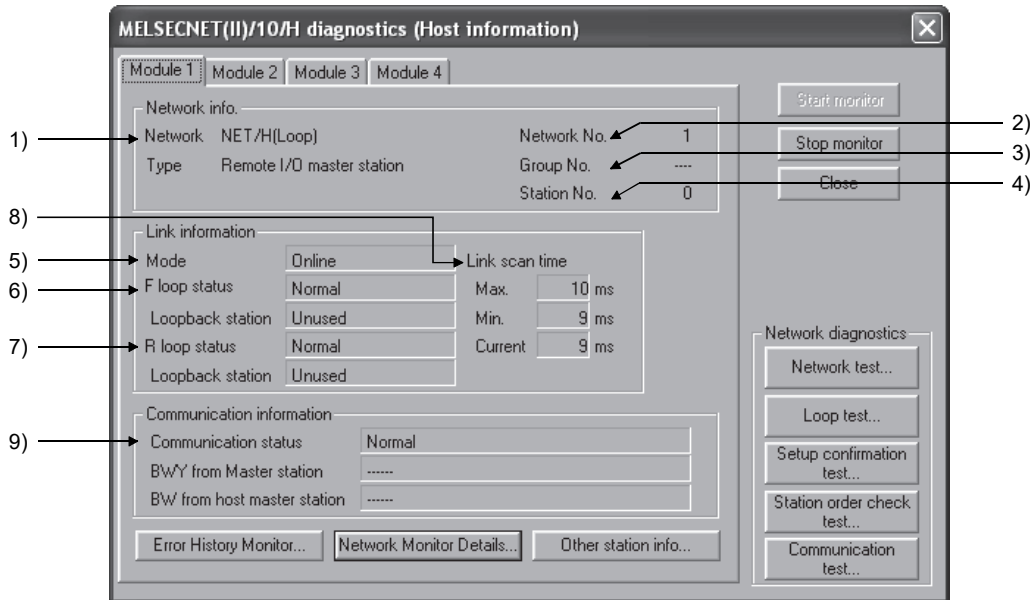

[Network info.]

- 1) Network type (SB0040, SB0044, SB0057, SW0046)
The network used and the type of the host station are displayed.
 - NET/H[Loop], Remote I/O master station
 - NET/H[Bus], Remote I/O master station
- 2) Network No. (SW0040)
The network No. of the host station is displayed.
- 3) Group No. (SW0041)
"---" is displayed.
- 4) Station No. (SW0042)
The station No. of the host station is displayed.

[Link information]

5) Mode (SW0043)

The operation mode of the host station is displayed.

- Online
- Offline
- Forward loop test
- Reverse loop test
- Station-to-station test (Station that executes tests)
- Station-to-station test (Station to be tested)

6) F loop status (SB0091), Loopback station (SB0099)

The status on the forward loop side is displayed.

- F loop status : Normal/Abnormal
- Loopback station : Unused/"Station number where loopback is executed"

"---" is displayed for the bus type.

7) R loop status (SB0095), Loopback station (SB009A)

The status on the reverse loop side is displayed.

- R loop status : Normal/Abnormal
- Loopback station : Unused/"Station number where loopback is executed"

"---" is displayed for the bus type.

8) Link scan time (SW006B/SW006C/SW006D)

The maximum/minimum/current values of the link scan time of the host station are displayed.

(Unit [ms])

Station type	Remote master station	Remote I/O station
Constant link scan		
Not set	Actual measurement value (The actual maximum/minimum/current values are displayed.)	
Set	Actual measurement value (The actual maximum/minimum/current values are displayed.)	Constant link scan ±2 ms

[Communication information]

9) Communication status (SB0047)

The communication status of the host station is displayed.

- Data link being executed (SB0047: Off)
- Data link stopped (SB0047: On)

POINT
The link information and communication information of the multiplexed remote sub-master station are not displayed.

8.1.2 Other station information

The status of communications, data link, parameters, CPU modules, and loops of other stations (including reserved stations) can be checked.

The buttons 3) and 7) can be clicked only when the diagnostics is executed from the remote master station.

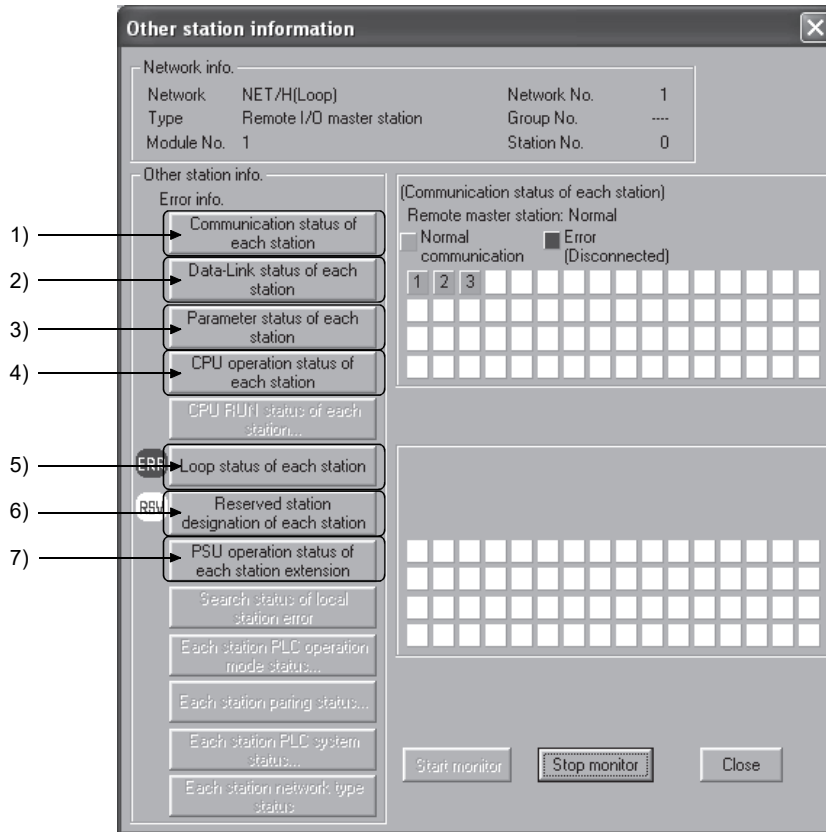

[Network info.]

The information same as "Host information" in Section 8.1.1 is displayed.

[Other station info.]

When the following situations are detected, the three-letter marks are displayed on the left of each item button.

Status	Display
When a faulty or STOP-status station is detected	ERR
When a reserved station exists	RSV
When power is supplied to a module with external power supply	PWR

Clicking each item button displays each station status corresponding to the item. The number of stations displayed on the right side of the window is the total number of link stations set in network parameter for the remote master station.

1) Communication status of each station (SW0070 to SW0073)

The baton pass status (transient transmission status) is displayed.

- Light blue : Communication normal station or reserved station
- Red : Communication error station (disconnected)

- 2) Data-Link status of each station (SW0074 to SW0077)
The cyclic transmission status is displayed.
 - Light blue : Normal station or reserved station
 - Red : Error station (data link not being performed)
- 3) Parameter status of each station
The parameter communication status of each station is displayed (SW0078 to SW007B).
 - Light blue : Parameters not being transferred, reserved station, or unconnected station
 - Red : Parameters being transferredThe parameter error status of each station is displayed (SW007C to SW007F).
 - Light blue : Parameters correctly set, reserved station, or unconnected station
 - Red : Parameter error
- 4) CPU operation status of each station (SW0080 to SW0083, SW0088 to SW008B)
The operation status of the remote I/O module is displayed.
The status is displayed for stations whose communication status is normal.
 - Light blue : Normal operation, reserved station, or unconnected station
 - Yellow : Minor error
 - Red : Moderate error (such as watchdog timer error), Major error (such as hardware error)
- 5) Loop status of each station (SW0091 to SW0094, SW0095 to SW0098)
For the optical loop system, the forward/reverse loop status is displayed.
 - Light blue : Normal loop operation, reserved station, or unconnected station
 - Red : Error
- 6) Reserved station designation each station (SW0064 to SW0067)
The reserved station setting status is displayed.
 - Light blue : Connected station
 - Red : Reserved station
- 7) PSU operation status of each station extension (SW008C to SW008F)
The status of the 24VDC external power supply built in the network module is displayed.
The status is displayed for stations whose communication status is normal.
 - Green : Power (24 V DC) not being supplied or network module without supply terminal
 - White : Power (24 V DC) being supplied

8.1.3 Network monitor details

The remote master station information, data link information, and parameter status of the host station can be checked.

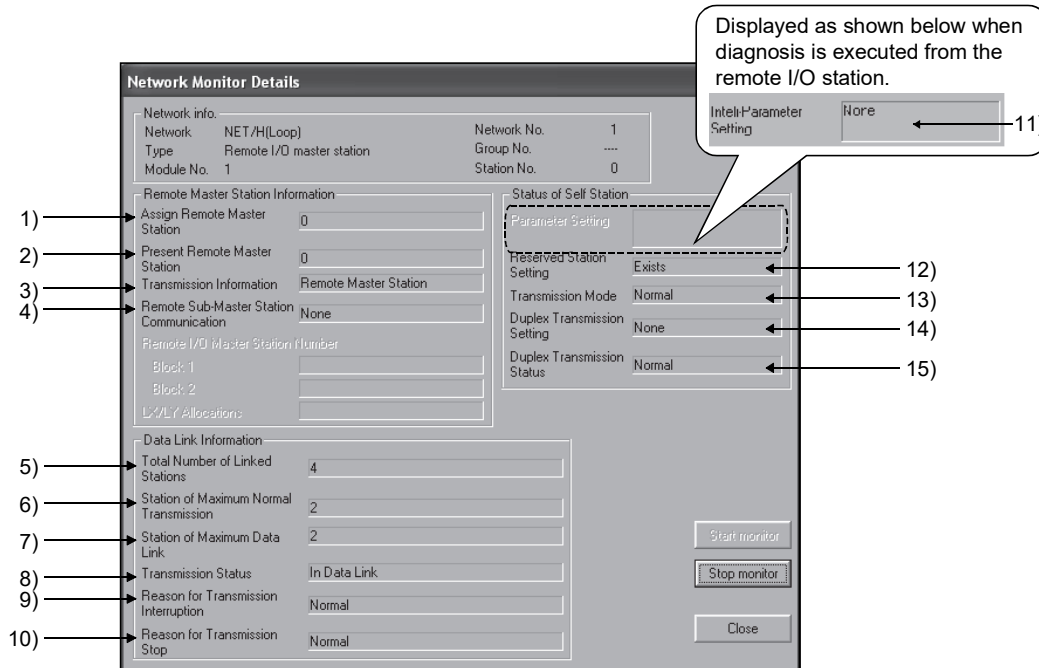

[Network info.]

The information same as "Host information" in Section 8.1.1 is displayed.

[Remote Master Station Information]

- 1) Assign Remote Master Station (SW0057)
The station number (0) of the remote master station is displayed.
- 2) Present Remote Master Station (SW0056)
The station number of the station which actually controls the remote I/O station is displayed.
- 3) Transmission Information (SB0056)
The type of the station which controls the remote I/O station is displayed. The displayed type is changed to the remote sub-master station automatically when the remote master station is down.
 - Remote Master Station
 - Remote Sub-Master Station Communication
- 4) Remote Sub-Master Station Communication (SB0058)
The cyclic transmission status (communication by the remote sub-master station) when the remote master station is down is displayed.
 - Yes
 - None

[Data Link Information]

- 5) Total Number of Linked Stations
The number of stations (the total number of link stations set in network parameter for the remote master station + 1 (remote master station)) is displayed.
- 6) Station of Maximum Normal Transmission (SW005A)
The greatest station number of the station where the baton pass (transient transmission) is normally performed is displayed.
On the station where the baton pass is normally performed, the T.PASS LED of the network module is on.
- 7) Station of Maximum Data Link (SW005B)
The greatest station number of the station where the data link (cyclic transmission and transient transmission) is normally performed is displayed.
On the station where the data link is normally performed, the D.LINK LED of the network module is on.
- 8) Transmission Status (SW0047)
The transmission status of the host station is displayed.

Status	Description
In Data Link	Data link is being executed.
Suspend Data link (Other)	Other station stopped the cyclic transmission.
Suspend Data link (Host)	The host station stopped the cyclic transmission.
Baton Pass (No area)	No area is assigned for the host's B/W transmission.
Baton Pass (Parameter Halt)	An error is identified in the host's parameters.
Baton Pass (No Receive)	The common parameters have not been received.
Disconnecting (No Baton)	The same station number has been set for two or more stations or the cable is not connected.
Disconnecting (Link Error)	The cable is not connected.
In Test	The online/offline test is being executed.
Resetting	Hardware fault

- 9) Reason for Transmission Interruption (SW0048)
The cause of the communication (transient transmission) failure of the host station is displayed.
For the corrective actions, refer to Section 8.3 "Error Codes".

Item	Description/Action
Normal	Communications being executed normally
Offline	In offline status
Offline Test	The offline test being executed
Initial state	In initial state (Error code: F101, F102, F105)
Shift Control Station	Error occurred (Error code: F104, F106)
Online testing	Error occurred (Error code: F103, F109, F10A)
Baton disappearance	Error occurred (Error code: F107)
Baton repetition	Error occurred (Error code: F108)
Same Station Present	Error occurred (Error code: F10B)
Control Station repetition	Error occurred (Error code: F10C)
Reception retry error	Error occurred (Error code: F10E)
Transmission retry error	Error occurred (Error code: F10F)
Timeout error	Error occurred (Error code: F110)
Network Disorder	Error occurred (Error code: F112)
Disconnecting...	Error occurred (Error code: F11B)
No baton to local station	Error occurred (Error code: F11F)
Error code: ****	Error occurred (Refer to the displayed error code.)

10) Reason for Transmission Stop (SW0049)

The cause of the data link (cyclic transmission) failure of the host station is displayed.

Item	Description
Normal	Communications being executed normally
There is a stop instruction (All)	Cyclic transmission to all stations is stopped from the host or other stations.
There is a stop instruction (Host)	Cyclic transmission of the host station is stopped.
Stop instruction present (□)	Cyclic transmission of the host station is stopped from another station (station No. □).
No Parameter	No parameter can be received.
Illegal Parameter	Set parameters are not correct.
Host PLC Error	A moderate or major error has occurred in the CPU module on the host station.
Suspend Communication	Data link error has occurred on the host station.

[Status of Self Station]

11) Intelli-Parameter Setting (SW0054)

The status of the intelligent function module parameters written to the remote I/O station is displayed.

- Available
- None

12) Reserved Station Setting (SB0064)

The specification status of the reserved station is displayed.

- Exists
- Does not exist

13) Transmission Mode (SB0068)

The status of the link scan is displayed.

- Normal
- Constant link scan

14) Duplex Transmission Setting (SB0069)

The specification status of the multiplex transmission is displayed.

- None
 - Multiplex transmission
- "----" is displayed for the bus type system.

15) Duplex Transmission Status (SB006A)

The status of the multiplex transmission is displayed.

- Normal
 - Multiplex transmission
- "----" is displayed for the bus type system.

8.1.4 Error history monitor

The history of forward/reverse loop errors, communication errors, and transient transmission errors can be checked. The details of the error history can be displayed and the error history can be cleared.

(1) Error history monitor

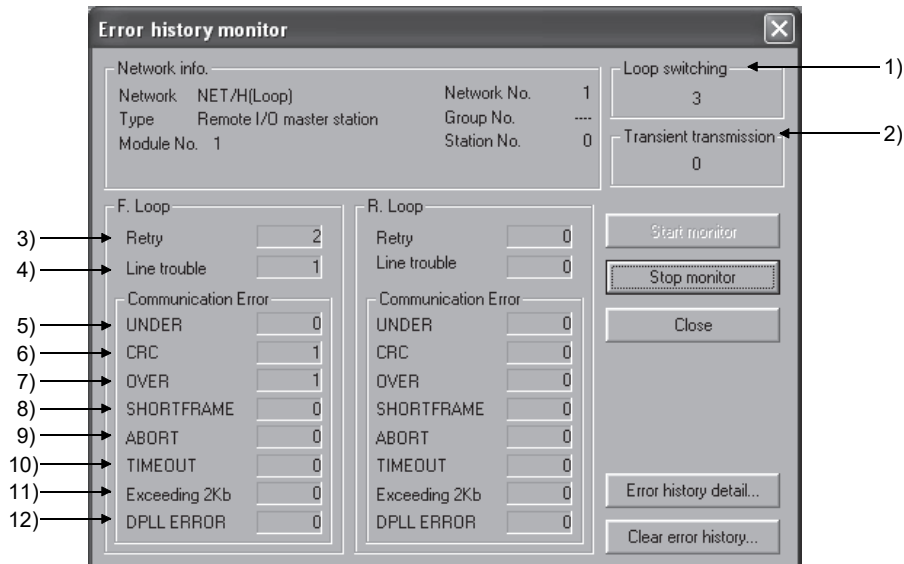

[Network info.]

The information same as "Host information" in Section 8.1.1 is displayed.

1) Loop switching (SW00CE)

The number of loop switchings is displayed.

<Error Cause> Such as power-ON/OFF of a station, a cable error, and noise

<Corrective Action> Refer to POINT on the next page.

2) Transient transmission (SW00EE)

The number of the transient transmission errors is displayed.

<Error Cause> Such as power-OFF of the target station, down of the CPU module of the target station, a cable error, and noise

<Corrective Action > Check the error code for the transient transmission error on the Error history detail monitoring window, and take the corrective action referring to Section 8.3.

[F. Loop, R. loop]

3) Retry (SW00C8, SW00C9)

The number of retries (communication retries in communication error) is displayed.

<Error Cause> Such as power-ON/OFF of a station, a cable error, and noise

<Corrective Action> Refer to POINT on the next page.

4) Line trouble (SW00CC, SW00CD)

The number of line errors is displayed.

<Error Cause> Such as power-OFF of the adjacent station, a cable error, and noise

<Corrective Action> Refer to POINT on the next page.

- 5) UNDER (SW00B8, SW00C0)
The number of UNDER errors is displayed.
<Error Cause> Such as power-ON/OFF of the adjacent station and a cable error
<Corrective Action> Refer to the following POINT.
- 6) CRC (SW00B9, SW00C1)
The number of CRC errors is displayed.
<Error Cause> Such as disconnection of the station which sends data to the corresponding station, a cable error, hardware failure, and noise
<Corrective Action> Refer to the following POINT.
- 7) OVER (SW00BA, SW00C2)
The number of OVER errors is displayed.
<Error Cause> Such as an cable error, hardware failure, and noise
<Corrective Action> Refer to the following POINT.
- 8) SHORTFRAME (SW00BB, SW00C3)
The number of short frame errors (the message is too short) is displayed.
<Error Cause> Such as an cable error, hardware failure, and noise
<Corrective Action> Refer to the following POINT.
- 9) ABORT (SW00BC, SW00C4)
The number of AB.IF errors is displayed.
<Error Cause> Such as disconnection of the station which sends data to the corresponding station, a cable error, hardware failure, and noise
<Corrective Action> Refer to the following POINT.
- 10) TIMEOUT (SW00BD, SW00C5)
The number of timeout errors is displayed.
<Error Cause> Such as monitoring time shortage, a cable error, and noise
<Corrective Action> Refer to the following POINT.
- 11) Exceeding 2Kb (SW00BE, SW00C6)
The number of receive errors (the data received is more than 2000 bytes) is displayed.
<Error Cause> Such as an cable error, hardware failure, and noise
<Corrective Action> Refer to the following POINT.
- 12) DPLL ERROR (SW00BF, SW00C7)
The number of DPLL errors is displayed.
<Error Cause> Such as an cable error, hardware failure, and noise
<Corrective Action> Refer to the following POINT.

POINT

<p>The number of errors is not actually a problem as long as the number does not increase frequently during the operation. If the number of errors, however, increases frequently, take the following corrective action.</p>
--

- | |
|---|
| <ol style="list-style-type: none"> 1) Check the power-ON/OFF status of the host station and other stations. 2) Check the connector for disconnection and looseness; and the cable for disconnection and length, referring to the following. <ul style="list-style-type: none"> · Reference manual for the network module used · User's manual for the CPU module used 3) Perform the self-loopback test, internal self-loopback test and hardware test. 4) Perform the station-to-station test, forward/reverse loop test. |
|---|

(2) Error history detail monitoring

The cause of loop switching and history of the transient transmission error are displayed.

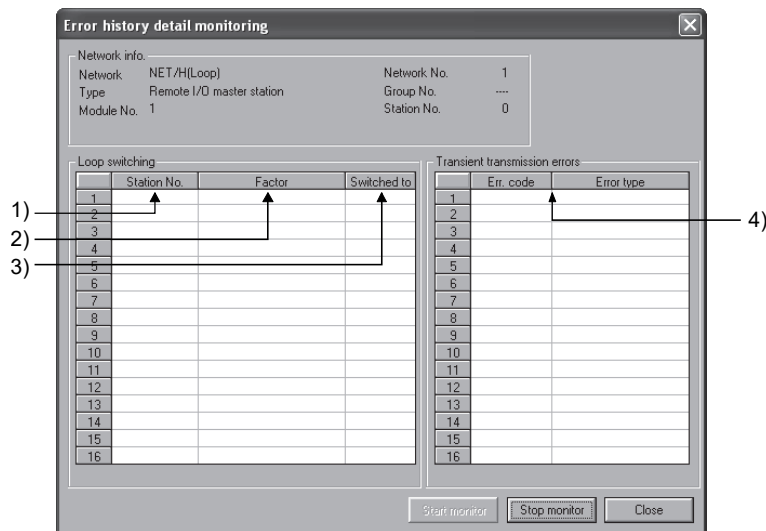

[Loop switching]

- 1) Station No. (SW00E0 to 00E7)
The station number which requested loop switching or loopback is displayed. (The station is not always the adjacent one.)
- 2) Factor (SW00D0 to 00DF)
The factor for the loop switching or loopback is displayed.
- 3) Switched to (SW00D0 to 00DF)
The data link status after loop switching is displayed.

[Transient transmission errors]

- 4) Err. code, Error type (SW00F0 to 00FF)
The error code is displayed.
Refer to Section 8.3

(3) Clear of error history

To clear error history, check the checkbox of the clear-target error history on the Clear of error history window. (Multiple items can be selected.)

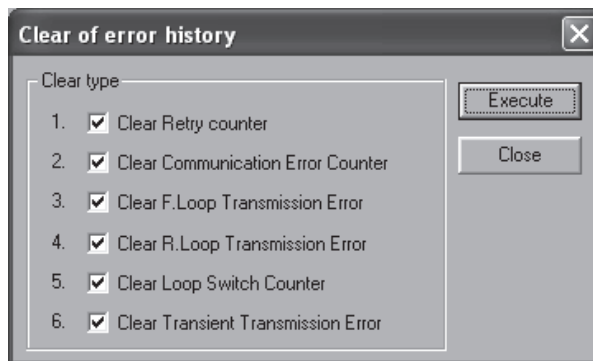

8.2 Troubleshooting

Check the programmable controller CPU for an error before starting the troubleshooting of the network module and network.

If the RUN LED of the programmable controller CPU is off/flickering or the ERR. LED is on, identify the error that has occurred in the programmable controller CPU, and take corrective action.

(1) Check that the host has joined the network.

Start the troubleshooting of the host by monitoring the status of the host.

First, check whether or not the host has joined the network.

This is important because it is not possible to monitor the status of other stations and to perform troubleshooting on other stations unless the host has joined the network.

The troubleshooting flowchart shown below explains the sequence from checking an error to enabling a baton pass (in order to join the network).

(a) For the master module

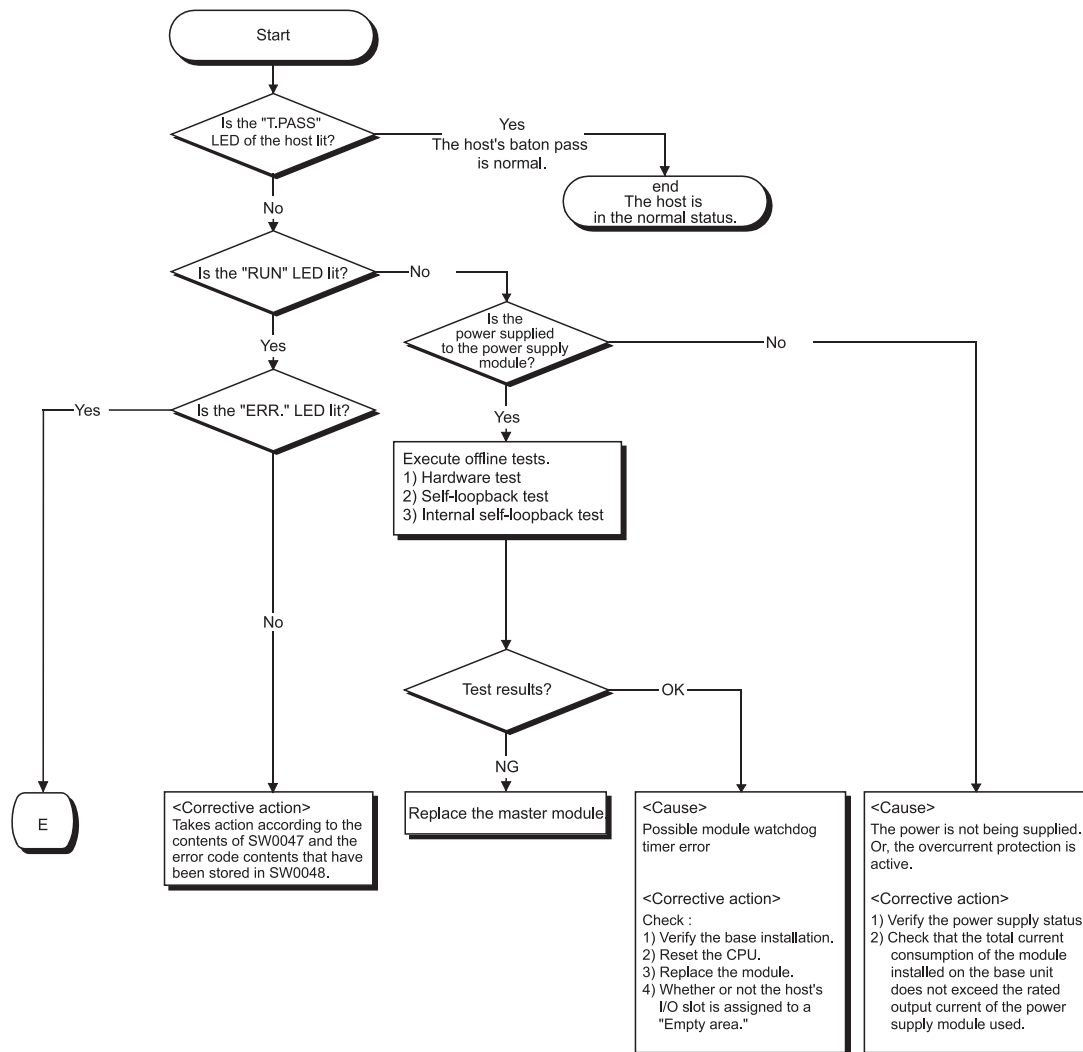

(b) For the remote I/O module

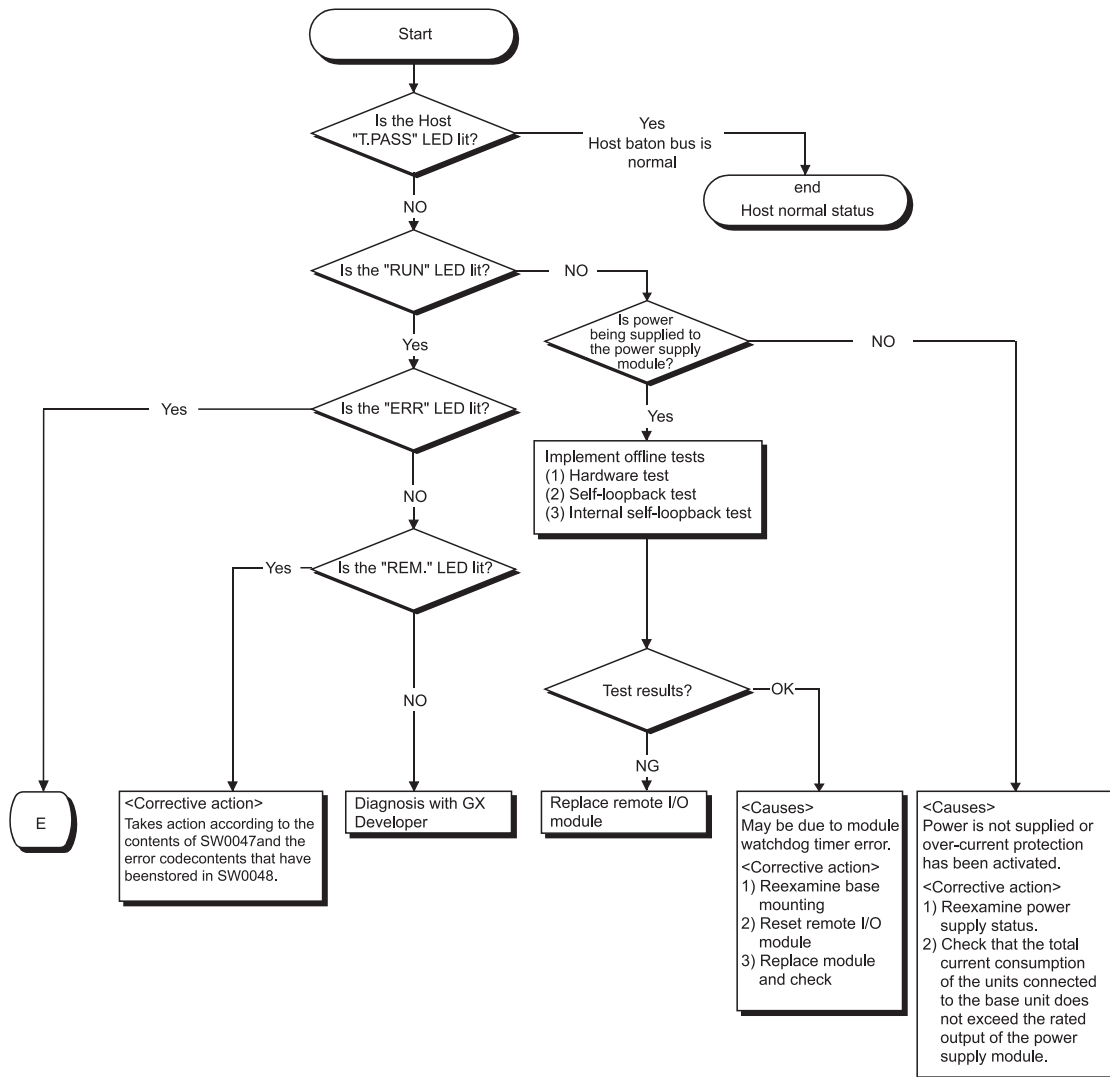

POINT
<p>If the status of the "T. PASS" LED is unstable, refer to the following.</p> <p><Cause> The line status may be unstable.</p> <p><Troubleshooting></p> <ol style="list-style-type: none"> 1) Check the connector for loose connection and the cable for a break. 2) Check that the cable used conforms to the specifications. 3) Check that the overall length and interstation distance conform to the specifications. (Refer to Section 4.8 Cable Connection.)

(2) From monitoring the network status to troubleshooting of a faulty station

The following flowchart illustrates the procedure for monitoring the status of the entire network, detecting a faulty station, and then performing troubleshooting for the applicable station.

The status of the entire network is monitored with GX Developer.

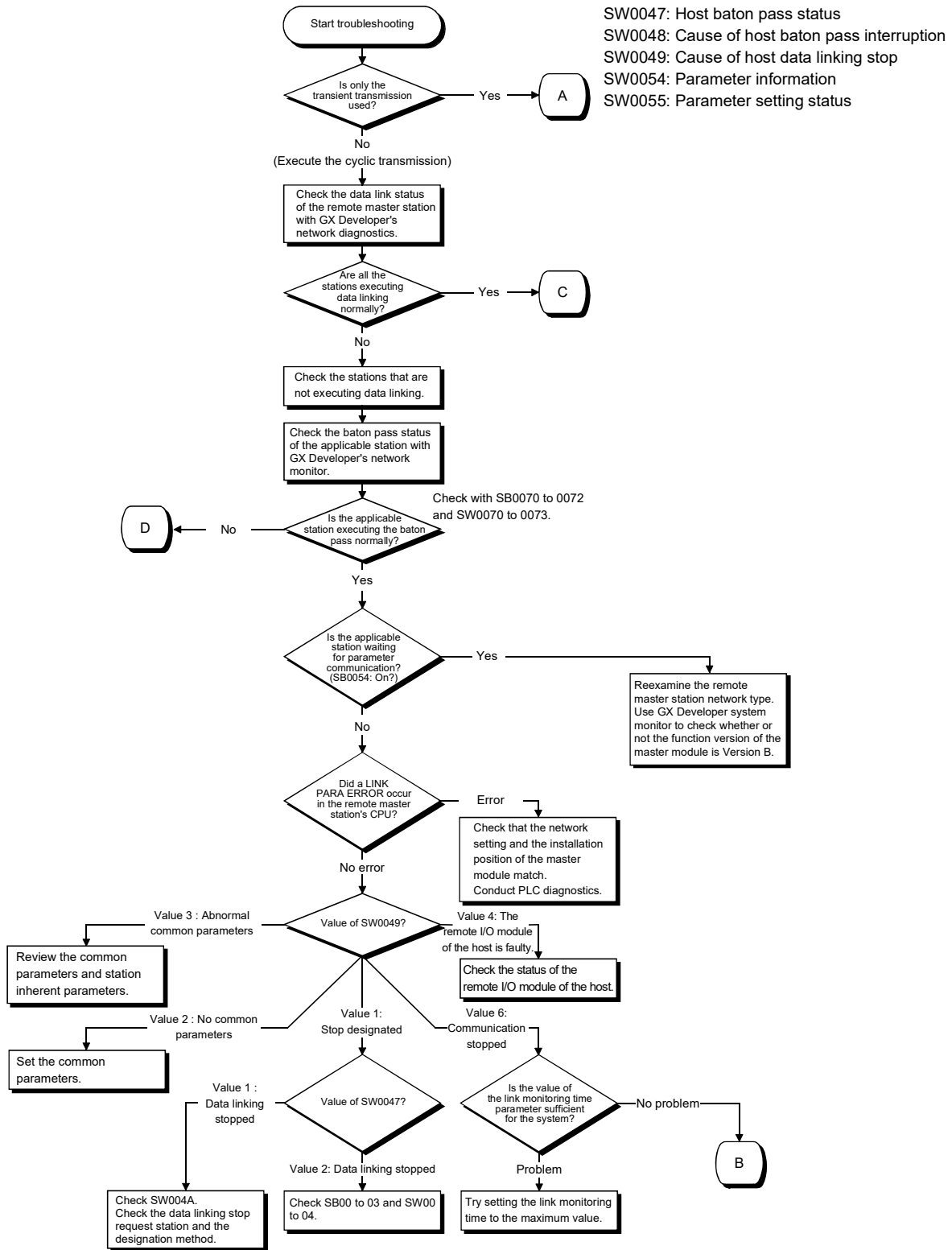

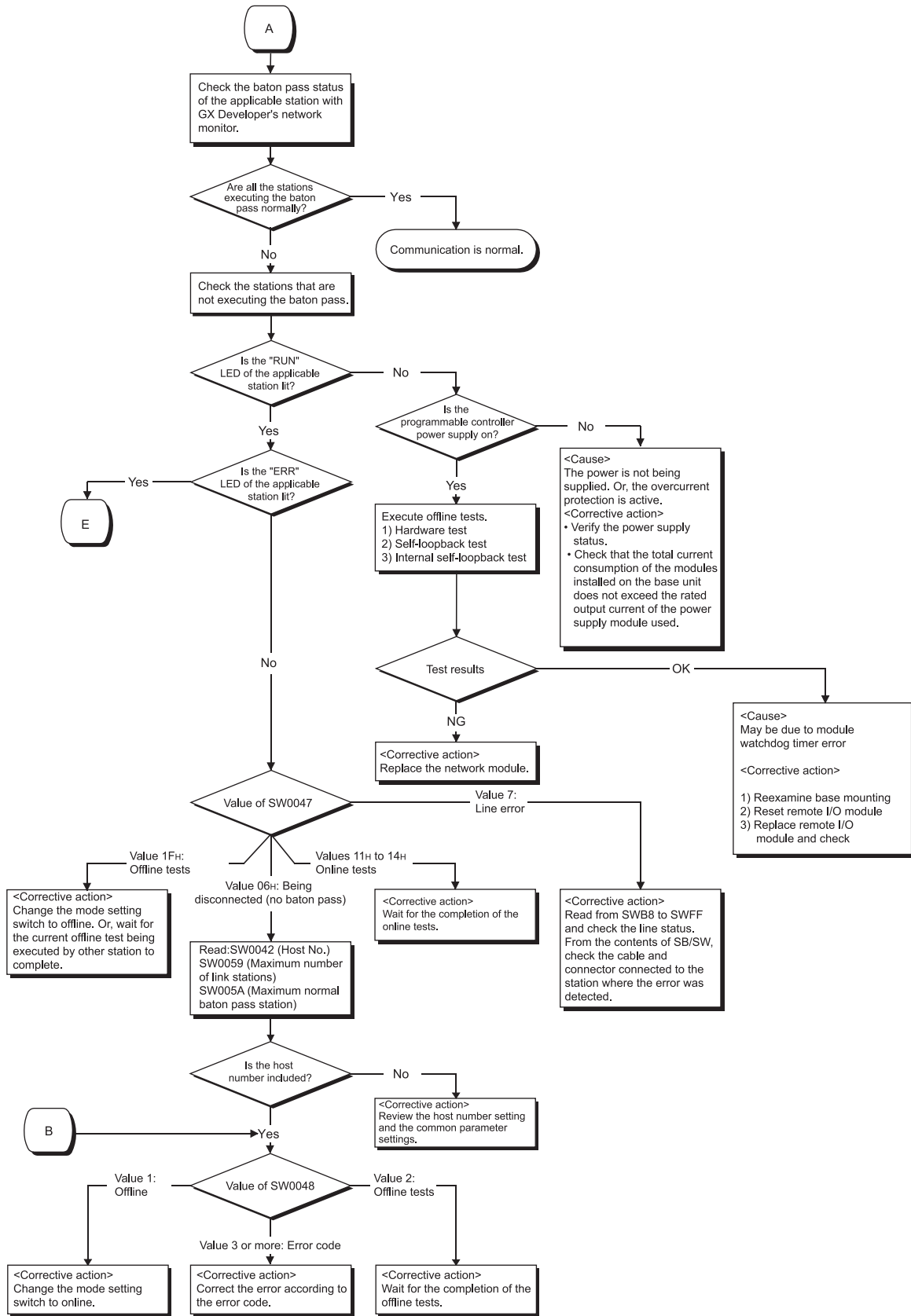

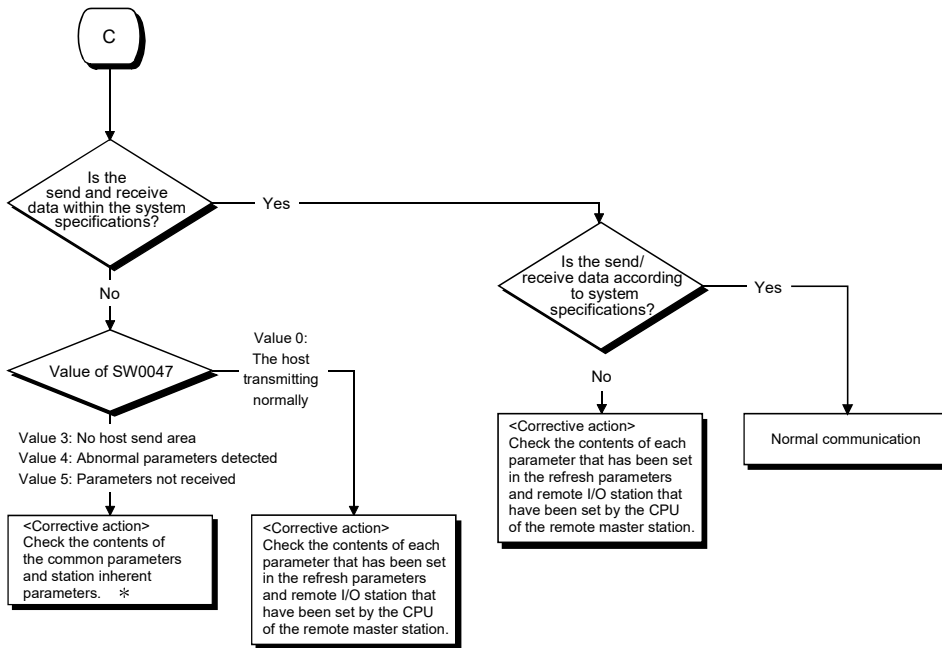

* : If SW0047=3, consider the following as a possible cause.
 Only the station number has been set in the common parameters and there is no link device assignment.

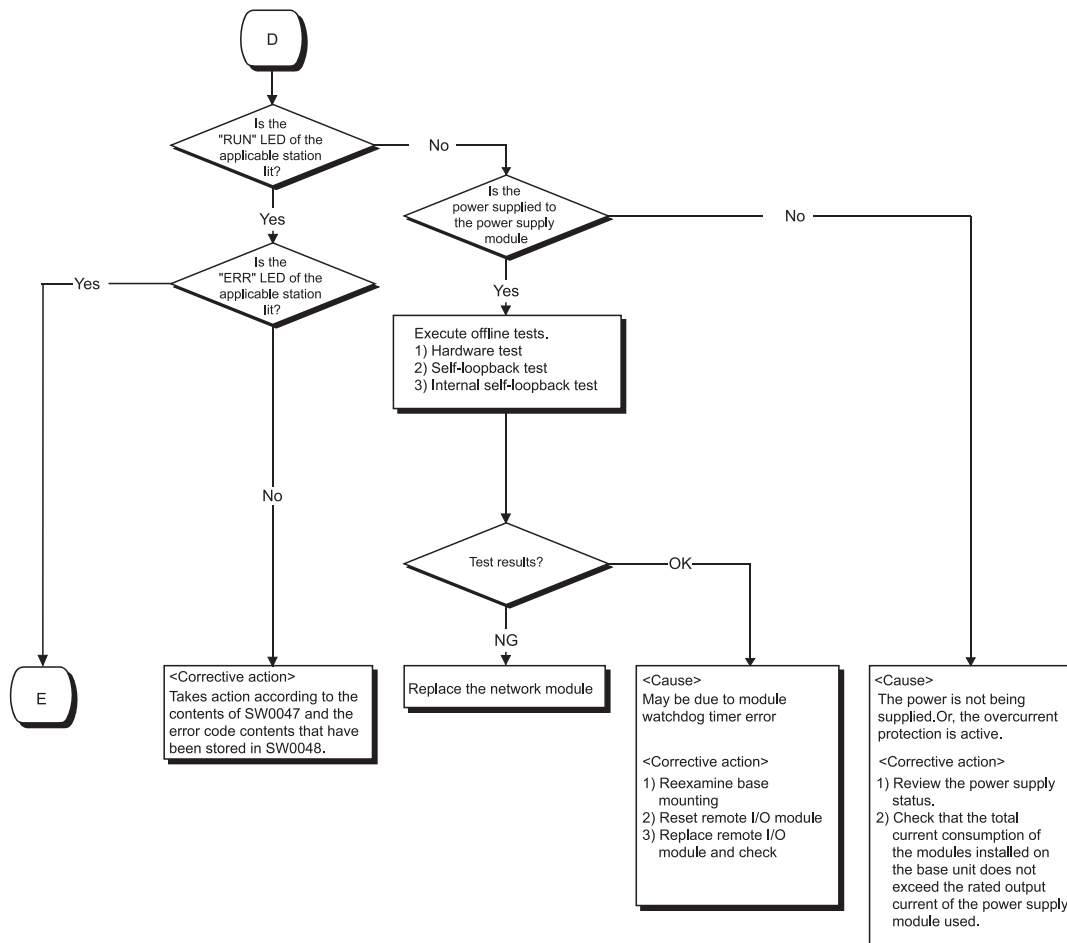



<Cause 1>
M/S error or SW error is assumed.

<Corrective action 1>

- 1) Check for duplicate station number, remote master station duplication or switch setting error.
- 2) Take corrective action according to the contents of SW0047 and the error code stored in SW0048.

<Cause 2>

Programmable controller CPU or remote I/O station error is assumed.

<Corrective action 2>

Check the programmable controller CPU or remote I/O station error in the PLC diagnostics and restore the CPU to normal. (Refer to Section 8.2.1.)

8.2.1 Items checked first

Check item	Checking procedure
Monitor the transmission status of each station with GX Developer's network diagnostics.	Check the CPU module status of the faulty station, the status of the network modules, the loop status of each station to search for the location where the error has occurred.
Is the "ERR." LED of the CPU module still lit or flickering?	Read the error code using GX Developer, and take proper measures against the error. (For details, refer to the QCPU User's Manual (Hardware Design, Maintenance and Inspection). Check the following when LINK PARA. ERROR occurs. 1) Check whether the starting I/O No. in the network setting matches the slot where the network module is installed. (Refer to Section 5.1.2.) 2) Check for consistency in the network type and the station number of the network module. (Refer to Section 5.1.1.) 3) Check if the PLC side device ranges in Refresh parameters are within the ranges set in [PLC parameter] - [Device]. (Refer to Section 5.1.5 (2).) If refresh parameters have not been set, set them according to the changes made in [Device] under [PLC parameter]. (Refer to Section 5.1.5 (3).)
Are the LEDs of the remote I/O station operating normally?	Check the "RUN", "ERR", and "L ERR" LEDs and take the corrective action if any error is found. (Refer to Section 4.2.)
Are the "RUN," "REM.," "T.PASS," and "D.LINK" LEDs of the remote I/O module on? Are the "ERR.," and "L ERR" LEDs off?	If the "RUN," "REM.," "T.PASS," and "D.LINK" LEDs are OFF or the "ERR." and "L ERR." LEDs are ON, diagnose the remote I/O module by GX Developer. (Refer to Section 4.2.) If the status of the "T. PASS" or "L ERR." LED is unstable, refer to the following. <Cause> The line status may be unstable. <Troubleshooting> 1) Check the connector for loose connection and the cable for a break. 2) Check that the cable used conforms to the specifications. 3) Check that the overall length and interstation distance conform to the specifications. (Refer to Section 4.8 Cable Connection.)
Are the "RUN" and "REM." LEDs on the remote I/O module on?	If the LEDs are out, use GX Developer to diagnose the remote I/O module.
Has the error reset process using SM50/SD50 been performed after the online module change function was executed on a remote I/O station?	Perform the error reset process by the procedure below after executing the online module change function. 1) Perform the error reset process on the remote I/O station. 2) Perform the error reset process on the programmable controller CPU of the master station.
Are the ERR contacts of the power supply modules of the remote master station and remote I/O station on?	1) If the ERR contact of the power supply module of the remote master station is OFF, check the status of the power supply connected to the power supply module of the remote master station, or diagnose by GX Developer if a stop error has not occurred on the CPU module of the remote master station. 2) If the ERR contact of the power supply module of a remote I/O station is OFF, check the status of the power supply connected to the power supply module of the remote I/O station, or diagnose by GX Developer if a stop error has not occurred on the remote I/O module of the remote I/O station. However, the ERR contact of the power supply module of the remote I/O station is turned off instantaneously when parameters are received from the remote master station after the parameters of the remote I/O station are changed. (The ERR contact is turned on when communication becomes ready due to the reception of parameters.)

8.2.2 Items checked when data link cannot be performed throughout the system

Check item	Checking procedure
Monitor the communication status of each station with GX Developer's network diagnostics.	Check the line condition with GX Developer's network diagnostic loop test (only in case of optical loop test). Check the faulty station's CPU module and network module. Check the network module and data link cable with the self-loopback test and station-to-station test of the offline tests. Check whether data linking is stopped for all stations.
Are the network parameters set for the remote master station?	Check whether the network parameters from the remote master station's CPU module are set.
Are the switch settings of the remote master station's master module correct?	Check the station number setting switches and mode setting switch.
Are the switches of the network modules on all stations set in the correct position?	Make sure that the mode setting switches of the network modules on all stations are in the same position.
Is the link monitoring time set to a sufficient value?	Set the link monitoring time to the maximum value and check whether or not data linking can be performed.
Did the remote master station go down?	Check the on/off status of the LEDs of the master modules of the remote master station.

8.2.3 Items checked when data link is disabled by resetting or powering off a station

Check item	Checking procedure
Is the cable wired properly?	Check the wiring status with GX Developer's network diagnostic loop test. (Refer to Section 4.10.1.) In the case of the coaxial bus system, check the coaxial connector connection on each station and connections between the coaxial cables and coaxial connectors.
Are the cables disconnected?	Check the status of each station to see whether the entire system is faulty or a specific station is faulty, and locate the faulty area.
Are the switches of the network modules on all stations set in the correct position?	Make sure that the mode setting switches of the network modules on all stations are in the same position.
Is the setting of the link monitoring time sufficient?	Set the link monitoring time to the maximum value and check whether or not data linking is possible. If the "L ERR" LED of a normal station is lit, check the TIME error with the GX Developer's network diagnostics.

POINT

Do not reset stations which are adjacent each other an optical loop system (adjacent stations on the wire) simultaneously (resetting by the reset switch of the remote I/O station or resetting by the key switches of the programmable controller CPUs of the remote master station and remote sub-master station). Otherwise, data link may not be able to be established.

If initialization and so on is necessary on adjacent stations simultaneously, turn off and on the power supply.

8.2.4 Items checked when cyclic data is 0 by resetting or powering on a station

Check item	Checking procedure
Is the send range latched?	Check whether B/W device in the send range is latched by latch setting of the CPU parameter.
Is the block data assurance per station of cyclic data set?	Check whether the block send data assurance per station is set.

POINT

A network module may send the initial value 0 in LB/LW data even B/W device in the send range of the CPU parameter is latched.

By setting the block send data assurance per station prevents cyclic data from being 0 since LB/LW data is sent after link refresh.

8.2.5 Items checked when data link cannot be performed on a certain station

Check item	Checking procedure
Monitor the transmission status of each station.	Perform network monitoring of the network diagnostics of GX Developer, check for any abnormally communicating station and check the loop status. Also, check whether or not data linking is stopped. In case of an optical loop system, check the line condition and transmission status of each station as well, using the loop test of GX Developer's network diagnostics.
Is the network module of the faulty station normal?	Check whether an error or problem has occurred in the CPU module and network module of the faulty station.
Was the loop error caused by the network module or the data link cable?	Check whether or not the network module works normally with the self-loopback test of the offline tests. Check whether or not the data link cable is normal with the loop test of the offline tests.
Are the remote master station's parameters correct?	Check that the total number of link stations is set to the largest number of the connected stations or more, and check that the stations that cannot communicate are designated as reserved stations.
Are the control station's parameters normal?	Read the network parameters from the faulty station's CPU module and check that the network settings such as the network type, start I/O number and network number are correct.
Are the switch settings of the network module correct?	Check the station number setting switch and the mode setting switch.
Has any data link cable been disconnected?	Perform the network monitoring or loop test in Network diagnostics of GX Developer to check the wiring status.

8.2.6 Items checked when an communication data error is detected

(1) Cyclic transmission

Check item	Checking procedure
Is the sequence program correct?	Stop the CPU modules of both the remote master station and turn the link device of the sending station on and off by GX Developer's test operation to check whether or not data is sent to the receiving station. If it is normal, review the sequence program. If it is abnormal, review the remote master station's common parameters and refresh parameters.
Are the parameter settings of the remote master station correct?	Review the range of the link devices assigned to the sending station. Check the setting of the refresh parameters to see in what range of LB/LW/LX/LY of the network module the device range used by the sequence program is stored.

(2) Transient transmission

Check item	Checking procedure
Has an error occurred while the transient transmission was being executed?	Check the error code at the transient transmission execution and correct the error according to the error code table in Section 8.3.
	Confirm the message screen of GX Developer and the error code of the response packet of the dedicated instruction/MELSEC communication protocol, and take measures based on the error code table in section 8.3.
	Confirm if transient transmission is executed for ACPU, QnACPU, or QCPU (except for Redundant CPU) by specifying the control system or standby system (error code 4B00).
	Confirm if transient transmission is executed for a single CPU system by specifying a CPU No. of a multiple CPU system (error code 4B00).
Response timeout occurs.	Confirm if a value out of the available range is set up for the CPU type of the target station.
Has the transient transmission is executed routing via the network module of standby system within the redundant system?	Change the routing settings of the network module on the control system.
Has a stop error occurred on the route CPU module or the CPU module of the target station in the redundant system?	Clear the stop error on the route CPU module or CPU module of the target station. Change the route station No. or the station No. of the target station.
Are the routing parameter settings correct?	Check the routing parameters with the communication test of GX Developer's network diagnostics.
Is the network No. parameter correct?	Check the network No. parameter. If the parameter is not set, the network No. has been set to 1 (default); so check other stations' network Nos.

8.2.7 Items checked when a link dedicated instruction does not complete

Check item	Checking procedure
Is the mode of the remote master station set to offline?	Set the mode of the remote master station to online and execute the link dedicated instruction again. Add SB0043 (Online switch (host)) as an interlock for execution of the link dedicated instruction so that the instruction is not executed offline.

8.2.8 Items checked when multiplexed remote I/O network for redundant system does not operate normally

- (1) Redundant CPU does not perform system switching even when the data link cable is disconnected.

Check item	Checking procedure
Isn't the power supply module of the standby system turned off?	Confirm the status of the external power supply of the standby system.
Hasn't a stop error occurred in the standby system CPU?	Connect GX Developer to the standby system CPU and execute PLC diagnostics to check if any error has occurred.
Hasn't an error occurred in the master module mounted on the main base unit of the standby system?	Confirm the operation status of the master module of the standby system.

- (2) Errors on a remote I/O station cannot be detected by the programmable controller CPU of the master operation station.

Check item	Checking procedure
Hasn't an error occurred on a remote I/O station with function version C or earlier?	Check the product information of the remote I/O module of the remote I/O station by the system monitor of GX Developer.

- (3) Cyclic data are turned off continuously or instantaneously when system switching is performed on Redundant CPU.

Check item	Checking procedure
Is the send range of the host a tracking range?	Confirm if the devices in the send range of the host is set as tracking devices with the parameters of GX Developer.

8.2.9 Items checked when a minor error (continue error) on a remote I/O station cannot be detected

Check item	Check procedure
Has SB000F of the remote master station turned ON?	Turn OFF SB000F of the remote master station.

8.2.10 Checking incorrect optical fiber cable connection during online

This section explains the checking procedure for incorrect optical fiber cable connection (IN-IN, OUT-OUT) during online and the link special registers (SW009C to SW009F) used for the check.

Unlike the loop test, the checking procedure given in this section allows a check without stopping a data link.

If incorrect cable connection is found, correct the wiring after shutting off all phases of the system.

POINT
Before starting the check given in this section, make sure that the following conditions are satisfied. If these are not satisfied, conduct a loop test to make a check. <ul style="list-style-type: none">▪ Multiplex transmission function is not used.▪ The optical fiber cables have no breaks. (Both the forward and reverse loop cables are normal.)▪ There are no stations having data link error (power off, MELSECNET/H module failure).

(1) Checking procedure

Follow the procedure given below to check for incorrect optical fiber cable connection (IN-IN, OUT-OUT) during online.

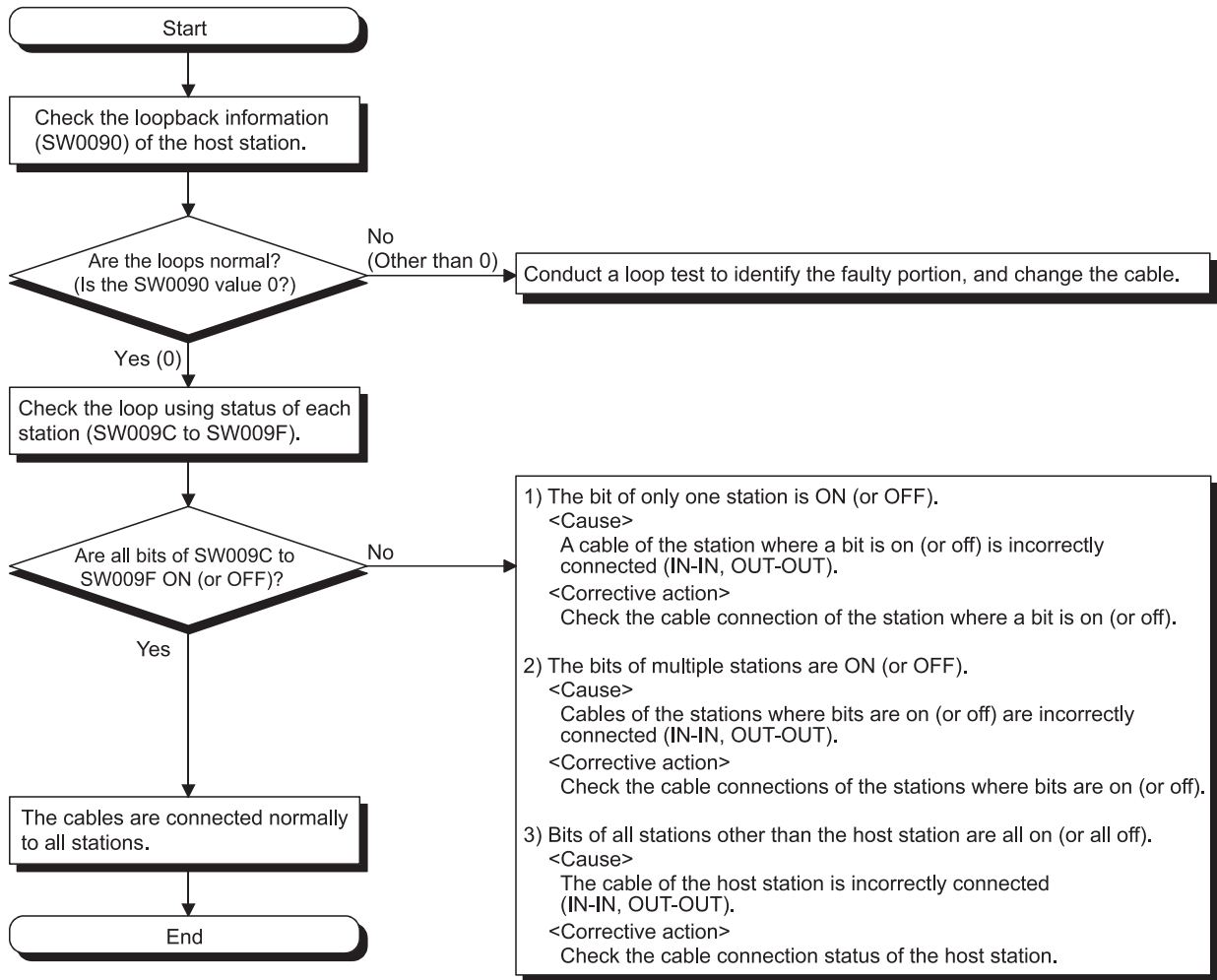

(2) Example of checking SW009C to SW009F

(a) When cables are connected incorrectly at a remote I/O station (Station No.2)

1) Wiring diagram

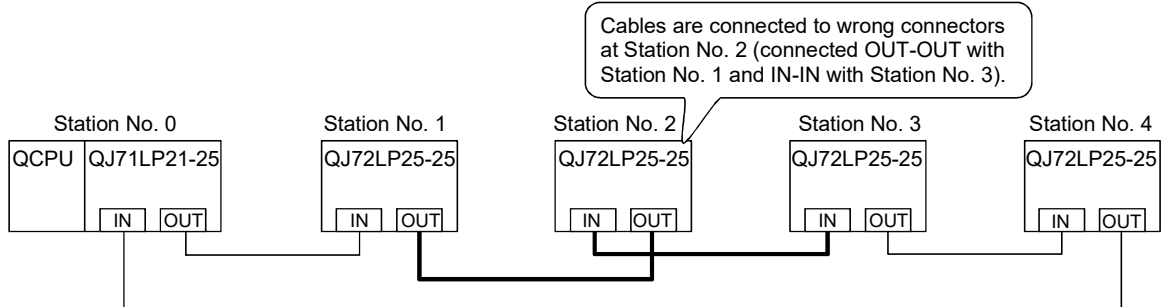

2) SW009C to SW009F status

Station No.	SW009C to SW009F status																																								
Station No. 1	Only Station No. 2 (bit 1) is ON or OFF. <table border="1"> <tr> <td></td> <td>b15</td> <td>to</td> <td>b4</td> <td>b3</td> <td>b2</td> <td>b1</td> <td>b0</td> </tr> <tr> <td>SW009C</td> <td>0</td> <td></td> <td>0</td> <td>0</td> <td>1</td> <td>0</td> <td></td> </tr> <tr> <td>SW009D</td> <td colspan="7">0</td> </tr> <tr> <td>SW009E</td> <td colspan="7">0</td> </tr> <tr> <td>SW009F</td> <td colspan="7">0</td> </tr> </table>		b15	to	b4	b3	b2	b1	b0	SW009C	0		0	0	1	0		SW009D	0							SW009E	0							SW009F	0						
		b15	to	b4	b3	b2	b1	b0																																	
SW009C		0		0	0	1	0																																		
SW009D		0																																							
SW009E	0																																								
SW009F	0																																								
Station No. 3																																									
Station No. 4																																									
Station No. 2	All stations (bit 0, bit 2, bit 3) than Station No. 2 (bit 1) are ON or OFF. <table border="1"> <tr> <td></td> <td>b15</td> <td>to</td> <td>b4</td> <td>b3</td> <td>b2</td> <td>b1</td> <td>b0</td> </tr> <tr> <td>SW009C</td> <td>0</td> <td></td> <td>1</td> <td>1</td> <td>0</td> <td>1</td> <td></td> </tr> <tr> <td>SW009D</td> <td colspan="7">0</td> </tr> <tr> <td>SW009E</td> <td colspan="7">0</td> </tr> <tr> <td>SW009F</td> <td colspan="7">0</td> </tr> </table>		b15	to	b4	b3	b2	b1	b0	SW009C	0		1	1	0	1		SW009D	0							SW009E	0							SW009F	0						
	b15	to	b4	b3	b2	b1	b0																																		
SW009C	0		1	1	0	1																																			
SW009D	0																																								
SW009E	0																																								
SW009F	0																																								

(b) When cables are connected incorrectly at the remote master station (Station No.0)

1) Wiring diagram

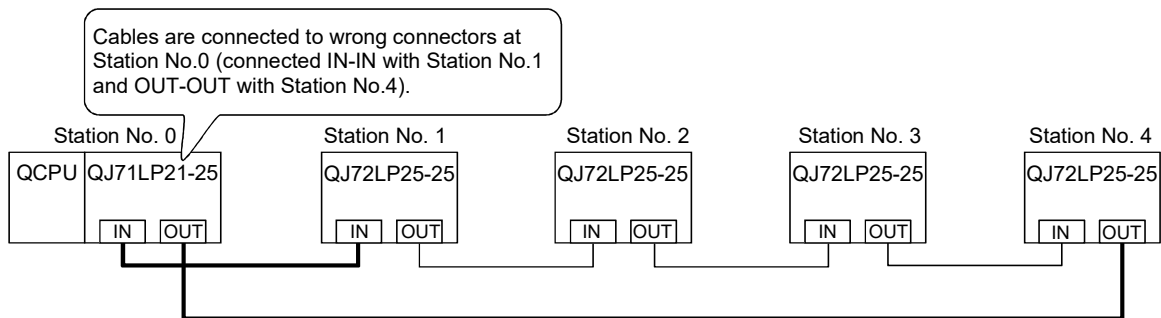

2) SW009C to SW009F status

Station No.	SW009C to SW009F status																																								
Station No. 1	All areas for Station No. 1 to 4 (bit0 to bit3) turn ON. <table border="1"> <tr> <td></td> <td>b15</td> <td>to</td> <td>b4</td> <td>b3</td> <td>b2</td> <td>b1</td> <td>b0</td> </tr> <tr> <td>SW009C</td> <td>0</td> <td></td> <td>1</td> <td>1</td> <td>1</td> <td>1</td> <td></td> </tr> <tr> <td>SW009D</td> <td colspan="7">0</td> </tr> <tr> <td>SW009E</td> <td colspan="7">0</td> </tr> <tr> <td>SW009F</td> <td colspan="7">0</td> </tr> </table>		b15	to	b4	b3	b2	b1	b0	SW009C	0		1	1	1	1		SW009D	0							SW009E	0							SW009F	0						
		b15	to	b4	b3	b2	b1	b0																																	
SW009C		0		1	1	1	1																																		
SW009D		0																																							
SW009E	0																																								
SW009F	0																																								
Station No. 2																																									
Station No. 3																																									
Station No. 4																																									

8.2.11 When a communication error such as a CRC error occurs frequently

Check item	Checking procedure
Is the optical fiber cable, the QJ71LP21, or QJ72LP25 faulty?	Power off all stations, then power on in order from the control station. At this time, check that the station where the communication error (such as the CRC error) count is increased to specify the error location. Replace the optical fiber cable or QJ71LP21 or QJ72LP25 where the error occurs with new one. For the module with the external power supply function (QJ71LP21S-25), power off the external power supply. The example shows as below.

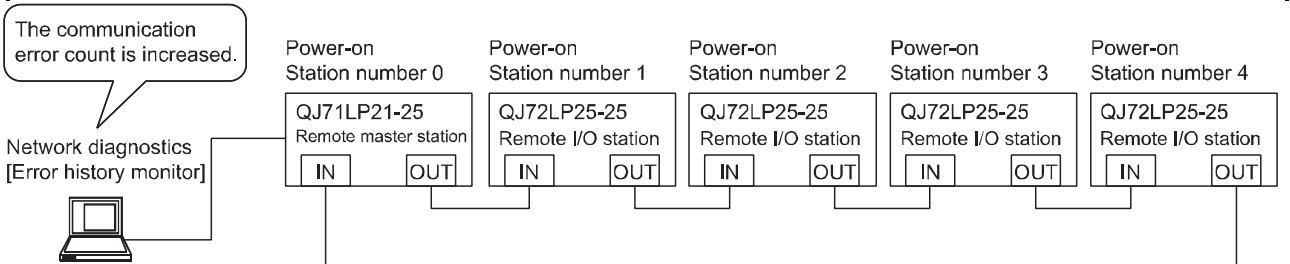

(1) Power off all stations.

For the module with the external power supply function (QJ71LP21S-25), power off the external power supply.

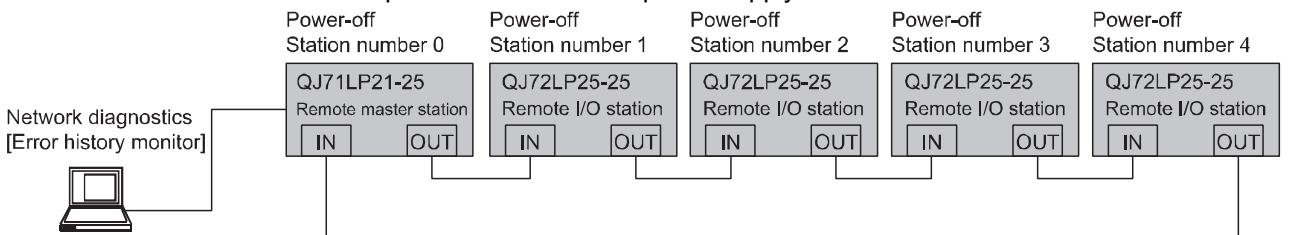

(2) Power on the remote master station (station number 0) and remote I/O station (station number 1).

Check whether the communication error count is increased on the error history monitor of the network diagnosis for a certain period of time.

If the communication error count is increased, the QJ72LP25-25 at the station number 0 or 1 is faulty or the optical fiber cable between the station number 0 or 1 is faulty.

When the communication error count is not increased, go to step (3).

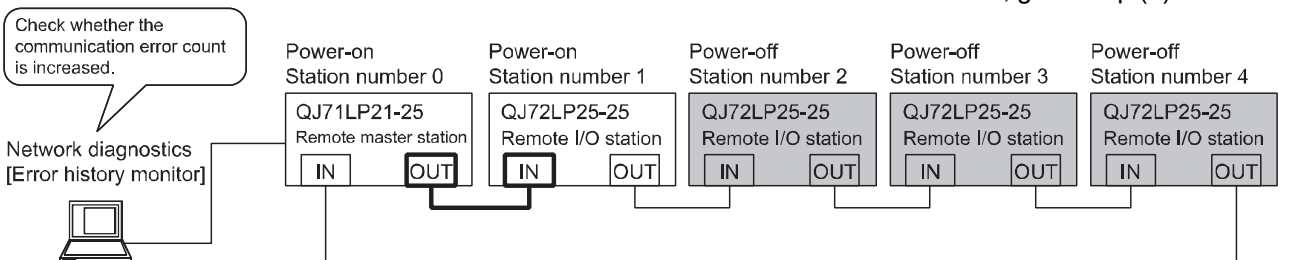

- (3) Power on the remote I/O station (station number 2).
 Check whether the communication error count is increased on the error history monitor of the network diagnosis for a certain period of time.
 If the communication error count is increased, the QJ72LP25-25 at the station number 1 or 2 is faulty or the optical fiber cable between the station number 1 or 2 is faulty.
 When the communication error count is not increased, go to step (4).

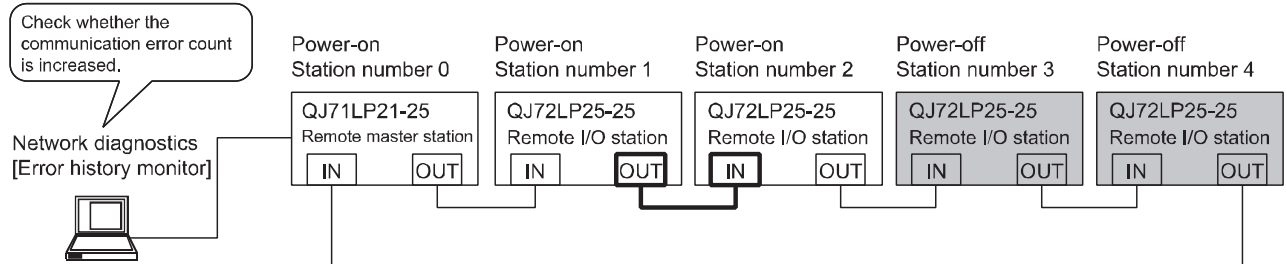

- (4) Power on the remote I/O station (station number 3).
 Check whether the communication error count is increased on the error history monitor of the network diagnosis for a certain period of time.
 If the communication error count is increased, the QJ72LP25-25 at the station number 2 or 3 is faulty or the optical fiber cable between the station number 2 or 3 is faulty.
 When the communication error count is not increased, go to step (5).

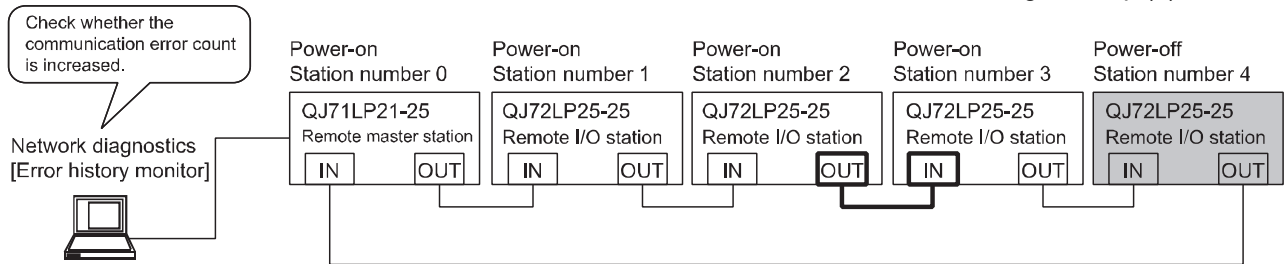

- (5) Disconnect the optical fiber cable from OUT side of the remote I/O station (station number 4), then power on the station.
 Check whether the communication error count is increased on the error history monitor of the network diagnosis for a certain period of time.
 If the communication error count is increased, the QJ72LP25-25 at the station number 3 or 4 is faulty or the optical fiber cable between the station number 3 or 4 is faulty.
 When the communication error count is not increased, go to step (6).

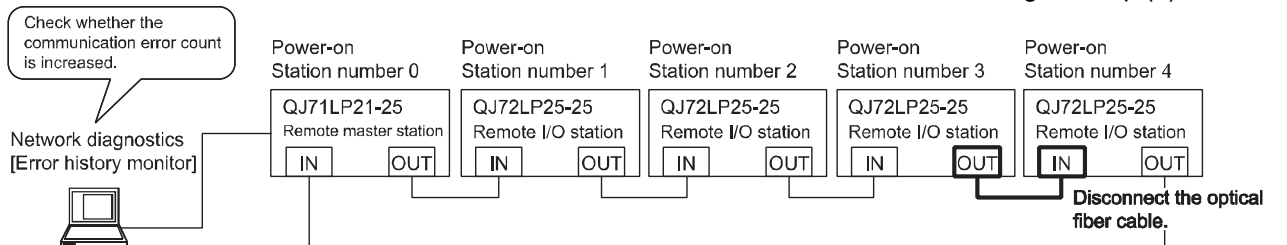

- (6) Connect the optical fiber cable to OUT side of the remote I/O station (station number 4).

Check whether the communication error count is increased on the error history monitor of the network diagnosis for a certain period of time.

If the communication error count is increased, the QJ72LP25-25 at the station number 4 or 0 is faulty or the optical fiber cable between the station number 4 or 0 is faulty.

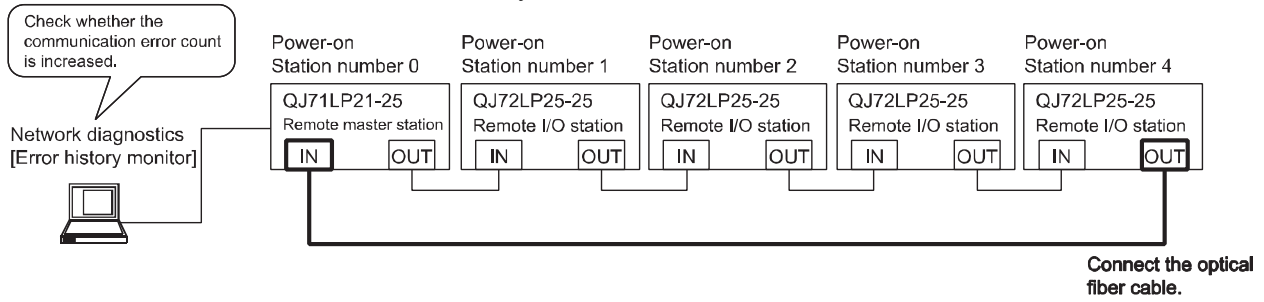

8.3 Error Codes

When a trouble such as data link failure has occurred, the error cause can be identified by using an error code.

8.3.1 How to check error codes

To check error codes for all network modules, follow either procedure (1) or (2) described in this section.

The codes can also be checked in link special registers (SW) and completion status of dedicated instructions. (Refer to (3) and (4) in this section.)

Remarks

By using GX Works2, the error history of the entire system can be checked even after errors were cleared by powering on and then off the programmable controller or by resetting the programmable controller CPU. (Refer to (2) (b) in this section)

(1) Checking with GX Developer

- 1) On GX Developer, select [Diagnostics] → [System monitor], and then click the **Module's Detailed Information** button.
- 2) On the "System Monitor" screen, select a network module and double-click on it.
The Module's Detailed Information screen and PLC diagnostics screen are displayed for the remote master station and remote I/O station respectively.

"System Monitor" screen for a remote master station

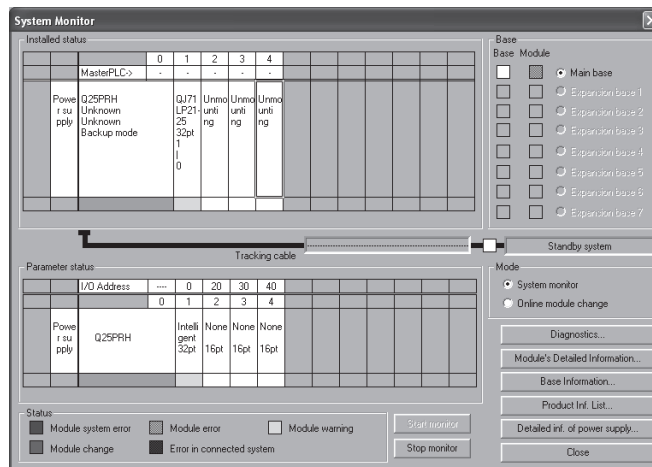

"System Monitor" screen for a remote I/O station

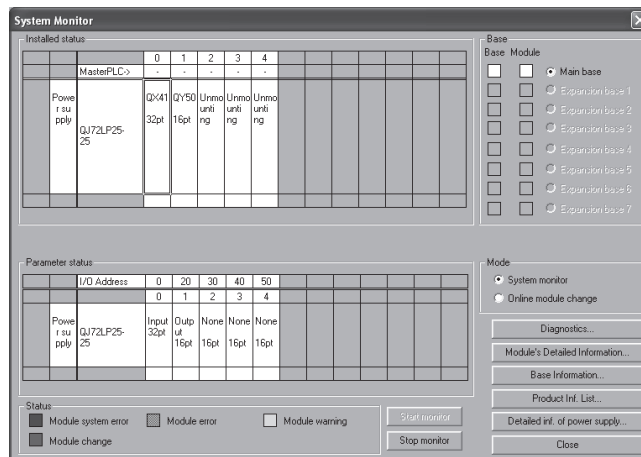

- 3) For the remote master station, check the error code, error history, description, and corrective action on the "Module's Detailed Information" screen.

"Module's Detailed Information" screen for a remote master station

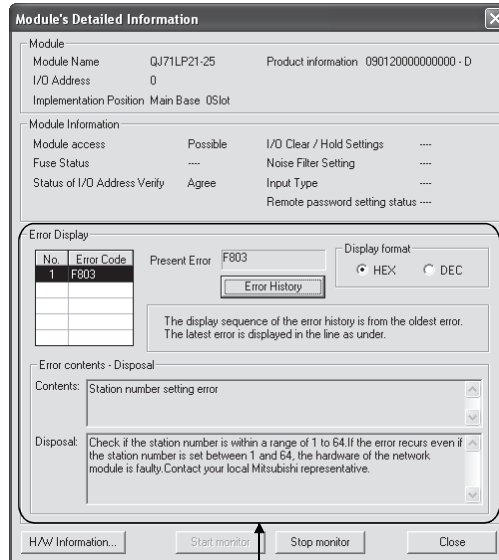

Check the codes, history, description, and action of an error of the master module

For remote I/O stations, check the present error and its history on the "PLC diagnostics" screen. *1

The **Clear log** button clears the error history.

"PLC diagnostics" screen of a remote I/O station

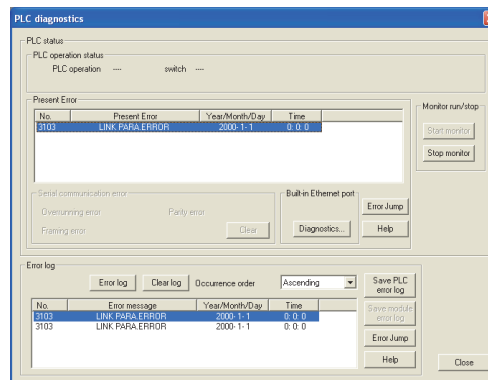

At the startup of the remote I/O network, if an error has occurred before the remote I/O station receives the clock data from the remote master station, the corresponding error time is displayed as January 1, 2000, 0:0:0.

If the communications are interrupted due to cable disconnection or any possible cause, the clock data will no longer be updated.

*1: If the remote I/O module whose serial number (first five digits) is "10012" or later is used, the error history is held even if the power is turned off.

POINT

The error time stored starts from "January 1, 2000 at 00:00:00".
 For example, "January 1, 2000 at 12:00:00" indicates that the error occurred 12 hours after the power-on.

(2) Checking with GX Works2

The error codes corresponding to the errors that have occurred in network modules can be checked by following either procedure (a) or (b) described below.

(a) Checking on the "Module's Detailed Information" screen

Error code, error contents, and corrective action are displayed.

On GX Works2, select [Diagnostics] → [System Monitor], and then click the

Detailed Information button.

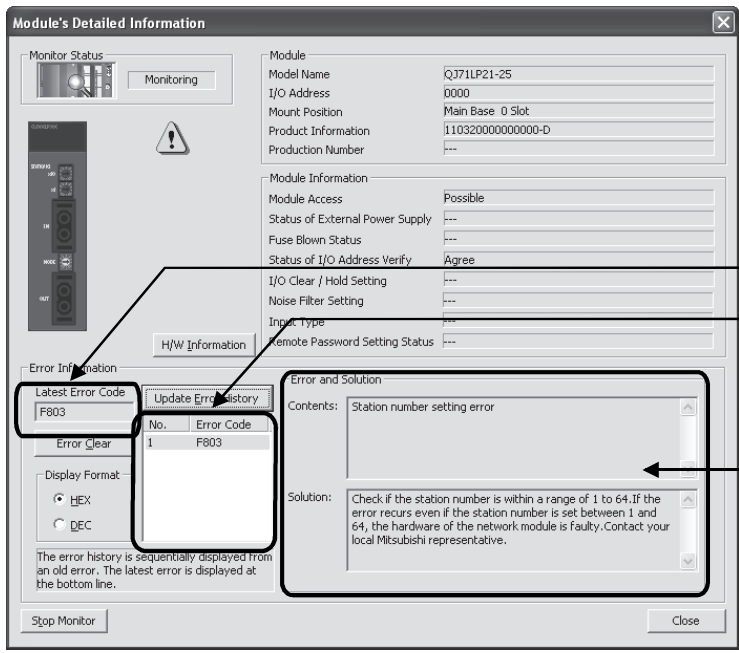

Displays the latest error code.

Displays error history.

Displays description of the error code that is currently selected under Error history and corrective action for the error.

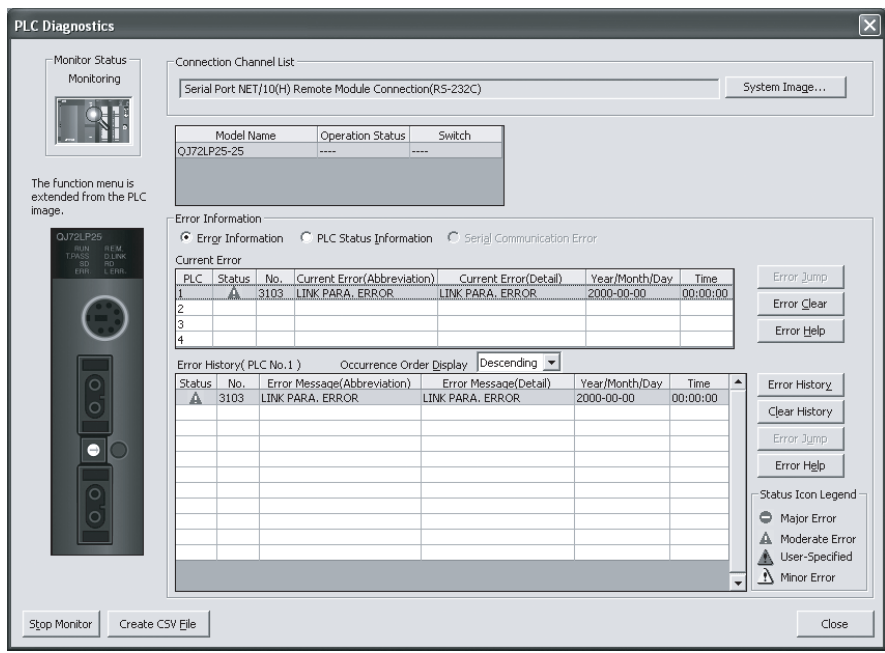

- (b) Checking on the "Error History" screen *¹ (remote master station only)
 On this screen, errors including those that have occurred in other modules are displayed, and the data can be output in a CSV file.
 The error code and date and time of error occurrence can be checked even after powering off and then on the programmable controller or after resetting the programmable controller CPU.

On GX Works2, select [Diagnostics] → [System Monitor], and then click the

System Error History button.

*1: Available on the programmable controller CPU, master module, and GX Works2 when their versions are respectively as follows.

Item	Version
Programmable controller CPU	Universal model QCPU with the first five digits of serial No. 11043
Master module	Master module with the first five digits of serial No. 11042
GX Works2	Version 1.12N or later

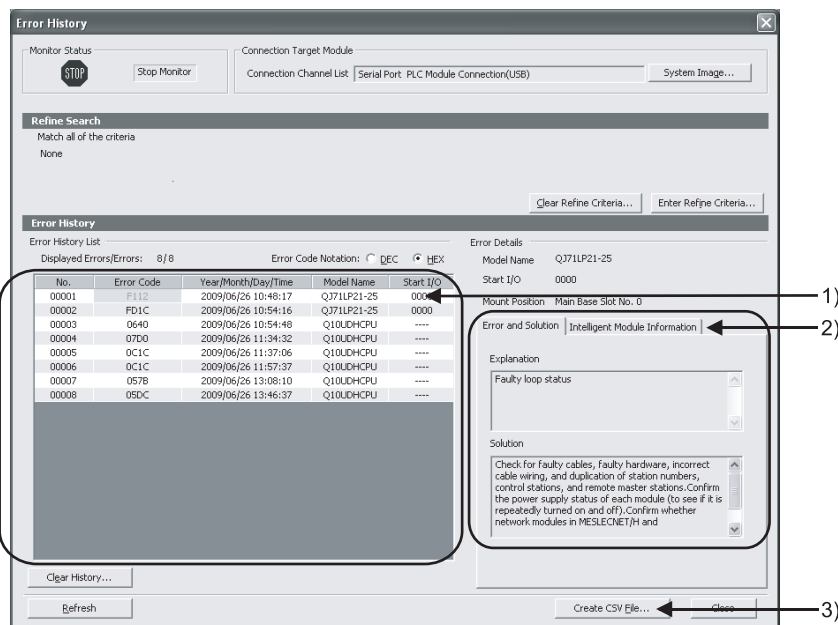

- 1) Error History List
 The error log of the module is displayed.
 For errors that have occurred during the initial processing of the programmable controller CPU, the date and time will be 0000/00/00 00:00:00; therefore the displayed order under the Error History List is not in the order in which the error has occurred.

2) Error and Solution, Intelligent Module Information

- Error and Solution
The error detail and corrective action for the error currently selected under "Error History List" are displayed.
- Intelligent Module Information
The error description and corrective action for the error, which is currently selected under "Error History List", are displayed. *¹

*1: When the error that simultaneously occurs with a network error is selected, the status right before the error occurrence may be displayed under Intelligent Module Information.

For the master module, the following will be displayed.

Item	Description
Baton pass status (host) (SW0047)	Baton pass status of the host station
Cause of data link stop (SW0049)	A cause of data link stop of the host station
Baton pass status of each station (SW0070 to SW0073)	Baton pass status of each station 0: Normal 1: Abnormal
Loopback station (forward loop side) (SW0099)	Station number of which station is performing a loopback in the forward loop. For the remote master station, [7DH] is displayed.
Loopback station (reverse loop side) (SW009A)	Station number of which station is performing a loopback in the reverse loop. For the remote master station, [7DH] is displayed.
Cyclic transmission status of each station (SW0074 to SW0077)	Cyclic transmission status of each station 0: Executing cyclic transmission 1: Cyclic transmission not executed
Dedicated instruction	Dedicated instruction on which an error has occurred
Target network number	Network number of a station to which a dedicated instruction was executed, resulted in an error
Target station number	Station number of a station to which a dedicated instruction was executed, resulting in an error

3) button

Click this button to output the module error history in a CSV file.

POINT

(1) If errors frequently occur in the master module, "**HST.LOSS**" may be displayed instead of error codes in the Error Code column.

(Example)

No.	Error Code	Year/Month/Day/Time	Model Name	Start I/O
00001	F112	2009/06/26 10:48:17	QJ71LP21-25	0000
00002	*HST.LOSS*	2009/06/26 10:54:16	QJ71LP21-25	0000

If too many "**HST.LOSS**" are displayed, increase the number of errors to be collected per scan in the "PLC RAS" tab of the "Q Parameter Setting" dialog box. For setting, refer to the user's manual (Function Explanation, Program Example) of the CPU module used.

(2) When the same errors consecutively have occurred, only the error code for the first error is displayed on the "Error History" screen.

8.3.2 MELSECNET/H error code list

Table 8.1 Error code list

Error code	Description	Corrective action
4000 to 4FFF	(Error detected by the programmable controller CPU)	Take measures referring to the QCPU User's Manual (Hardware Design, Maintenance and Inspection).
7000 to 7FFF	(Error detected by the serial communication module, etc.)	Take measures referring to the troubleshooting section of the Serial Communication Module User's Manual.
B000 to BFFF	(Error detected by the CC-Link module)	Take measures referring to the troubleshooting section of the CC-Link System Master/Local Module User's Manual.
C000 to CFFF	(Error detected by the Ethernet module)	Take measures referring to the troubleshooting section of the Ethernet Interface Module User's Manual.
D000 to DFFF	(Error detected by CC-Link IE Field Network)	Take measures referring to the troubleshooting section of the CC-Link IE Field Network User's Manual.
E000 to EFFF	(Error detected by CC-Link IE Controller Network)	Take measures referring to the troubleshooting section of the CC-Link IE Controller Network Reference Manual.
F101	Initial status (Network activated)	Wait until SB0047 (baton pass status) and SB0049 (data link status) turn off (normal).
F102	Initial status (Network activated)	
F103	Initial status (during online test)	
F104	Initial status (Control/sub-control station shift)	
F105	Initial status (Parameters being processed)	
F106	Shift from failed control station to sub-control station	Check the condition of the control station's power supply and of the cables and the status of the control station CPU module.
F107	Baton pass error (baton lost)	Check the line status for a faulty cable or a missing terminating resistor, as well as the stations that are not powered on. In the case of the PLC to PLC network, when transient transmission is executed frequently and the link scan time may exceed 200 ms, adjust the transient setting values to reduce the link scan time.
F108	Baton pass error (duplicate baton)	Execute a setup confirmation test to check whether the same station number has been set for two or more stations or whether two or more control stations exist. Check for faulty cables, wire breakage, poor connector connections, connection errors, uninstalled or loose terminating resistors, etc.
F109	Initial status (during online test)	Wait until SB0047 (baton pass status) and SB0049 (data link status) are recovered.
F10A	Initial status (online test/offline loop test)	<During execution of an online test> Wait until SB0047 (baton pass status) and SB0049 (data link status) are recovered. <During execution of an offline test> Change the switch setting to online after the test has been completed.
F10B	Duplicate station number error	Review the station number setting. The setup confirmation test of network diagnosis is effective.
F10C	Duplicate control station error	Review the station number setting. The setup confirmation test of network diagnosis is effective.
F10D	Offline status	Review the mode setting, and change it to online.
F10E	Number of receive error retries exceeded	Check for faulty cables, faulty hardware, incorrect cable wiring, absence of terminating resistor (in the case of the bus), and existence of different communication speeds on the same network. In addition, check whether the same station number has been set for two or more stations or whether two or more control stations or remote master stations exist. The setup confirmation test and loop test of network diagnosis are effective.
F10F	Number of send error retries exceeded	
F110	Timeout error	

Table 8.1 Error code list (Continued)

Error code	Description	Corrective action
F111	Corresponding station error (Baton pass to the corresponding station not executed)	Review the status of the corresponding station and the parameter and switch settings (to see if there is a parameter error and the corresponding station is the control station and properly set). Confirm the power supply status of the corresponding station (to see if it is repeatedly turned on and off). Check for faulty cables, faulty hardware, incorrect cable wiring, absence of terminating resistor (in the case of the bus), and existence of different communication speeds on the same network. In addition, check whether the same station number has been set for two or more stations or whether two or more control stations or remote master stations exist. The setup confirmation test and loop test of network diagnosis are effective.
F112	Faulty loop status	Check for faulty cables, faulty hardware, incorrect wiring, and existence of different communication speeds on the same network. In addition, check whether the same station number has been set for two or more stations or whether two or more control stations or remote master stations exist. Confirm the power supply status of each module (to see if it is repeatedly turned on and off). Confirm whether network modules in MESLECNET/H and MELSECNET/10 modes exist together (confirm the control station type).
F113	Send failure (Baton pass to the host station not executed)	Retry after a little while. If the error reoccurs as a result of a retry, check for faulty cables, faulty hardware, incorrect cable wiring, absence of terminating resistor (in the case of the bus), and existence of different communication speeds on the same network. In addition, check whether the same station number has been set for two or more stations or whether two or more control stations or remote master stations exist. Wait until SB0047 (baton pass status) and SB0049 (data link status) are recovered.
F114	Send failure	Retry after a little while. If the error reoccurs as a result of a retry, check for faulty cables, faulty hardware, incorrect cable wiring, absence of terminating resistor (in the case of the bus), and existence of different communication speeds on the same network. In addition, check whether the same station number has been set for two or more stations or whether two or more control stations or remote master stations exist. Wait until SB0047 (baton pass status) and SB0049 (data link status) are recovered.
F115	Improper function code	Check for faulty cables, faulty hardware, incorrect cable wiring, and existence of different communication speeds on the same network. In addition, check whether the same station number has been set for two or more stations or whether two or more control stations exist.
F116	Delayed online test processing	Check for faulty cables, hardware failure, noise, incorrect wiring, and absence of terminating resistors (when a bus is used).
F117	Send failure	Wait until SB0047 (baton pass status)/SB0049 (data link status) is turned off (normal).
F118	Send failure (baton regeneration)	Wait for a while and execute again.
F11A	Send failure (multiplex transmission stopped)	
F11B	Being disconnected	Review the parameter and switch settings (to see if there is a parameter error and the corresponding station is the control station or remote master station and properly set). Check for faulty cables, faulty hardware, and incorrect wiring. In addition, check whether the same station number has been set for two or more stations or whether two or more control stations or remote master stations exist.
F11C	System error	The hardware of the network module is faulty. Please consult your local Mitsubishi representative.

Table 8.1 Error code list (Continued)

Error code	Description	Corrective action
F11F	Initial status (no baton addressed to host)	Check for the operation status of the control/sub-control station, faulty cables, incorrect cable wiring, absence of terminating resistor (in the case of the bus), and existence of different communication speeds on the same network. In addition, check whether the same station number has been set for two or more stations or whether two or more control stations or remote master stations exist. Confirm whether network modules in MESLECNET/H and MELSECNET/10 modes exist together (confirm the control station type).
F120	Destination station specification error	Check for faulty cables, faulty hardware, incorrect wiring, absence of terminating resistor (in the case of the bus), and existence of different communication speeds on the same network. In addition, check whether the same station number has been set for two or more stations or whether two or more control stations or remote master stations exist.
F122	Send failure (coaxial bus system)	Check for coaxial cable connection, proper connector connection, connection of terminating resistor, or faulty cables.
F221	System error	The hardware of the network module is faulty. Please consult your local Mitsubishi representative.
F222	No free area in the receive buffer (buffer-full error)	Retry after a little while. If the error reoccurs as a result of a retry, review the number of transient communication times and communication interval of the entire system. Turn off the power supply to the entire system, and turn it on again.
F224	Receive data size error	The hardware of the module on the transient transmission source station is faulty. Please consult your local Mitsubishi representative.
F225	Logical channel number error	The hardware of the module on the transient transmission source station is faulty. Please consult your local Mitsubishi representative.
F226	Channel number error	Check if the logical channel number designated in the execution source of the SEND instruction is set in the target network module. Alternatively, specify the logical channel number set in the target network module.
F228	SEND instruction target station error	Review the target network number and target station No. in the control data at the execution source of the SEND instruction.
F301	System error	The hardware of the network module is faulty. Please consult your local Mitsubishi representative.
F701	Send-target station number error (station No. 0 specified)	Review the send-target station number.
F702	Send-target station number error (station No. 65 or higher number specified)	
F703	Destination group number error	Review the destination group number.
F706	Received data size error	The cable is faulty, or the hardware of the network module is faulty. If a communication error has occurred, review the cable. If not, the hardware of the network module is faulty. Please consult your local Mitsubishi representative.
F707	Number of relay stations invalid	Set stations to which data can be sent. Review the system. Review the routing parameters.
F708	Receiving group number error	Review the group number of the target station.
F709	Receiving network number error	Review the network No. of network parameter for the host station and a target station. If the parameter is not set, the network No. is preset to 1 (default); so check the network No. of other stations.
F70A	System error	The cable is faulty, or the hardware of the network module is faulty. If a communication error has occurred, review the cable. If not, the hardware of the network module is faulty. Please consult your local Mitsubishi representative.

Table 8.1 Error code list (Continued)

Error code	Description	Corrective action
F70B	Response wait timeout	Wait until SB0047 (baton pass status) and SB0049 (data link status) are recovered.
F70C	System error	The cable is faulty, or the hardware of the network module is faulty. If a communication error has occurred, review the cable.
F70E	System error	If not, the hardware of the network module is faulty. Please consult your local Mitsubishi representative.
F710	System error	The hardware of the network module is faulty. Please consult your local Mitsubishi representative.
F711	System error	
F712	System error	
F781	Connection target specification error	Check if C24 connection or CC-Link connection is specified for access to other stations. If the setting is correct, the hardware of the CPU or network module is faulty. Please consult your local Mitsubishi representative.
F782	System error	The hardware of the CPU or network module is faulty. Please consult your local Mitsubishi representative.
F783	System error	The hardware of the network module is faulty. Please consult your local Mitsubishi representative.
F7C1	Host station channel in use	The same channel cannot be used at the same time. Change the channel number. Alternatively, do not use the same channel at the same time.
F7C2	Target station channel in use	Retry the SEND instruction after a little while. Check if the target station uses the channel concerned to execute the instruction, or if RECV processing is executed. Check if another station executes the SEND instruction to the target station's channel.
F7C3	Arrival monitoring timeout	<When this error occurs by the RECV instruction> When another station is executing the SEND instruction, increase the value of the arrival monitoring time. Alternatively, start the RECV instruction by turning the RECV instruction execution request flag to ON. <When this error occurs in other cases> Increase the value of the arrival monitoring time. Confirm the operation status of the target station, the network status, and the relay station status (in the case of sending to other network).
F7C4	Resend count-out	Increase the arrival monitoring time. Re-execute the REMFR/REMTO instruction. Confirm the operation status of the target station, the network status, and the relay station status (in the case of sending to other network).
F7C5	SEND instruction target station error	Review the target network number and target station No. in the request control data of send/receive instructions.
F7C6	Channel number setting out of range	Set the channel numbers of the host station and of the target station in the request control data of send/receive instructions within a range between 1 and 64.
F7C7	Target station specification error (host station specification)	Specify the target station number in the request control data of send/receive instructions to other than the number of host station.
F7C8	Execution type specification error	When the execution/abnormal completion type in the request control data of send/receive instructions is specified for all stations or groups, set "No arrival confirmation" for the execution type.
F7C9	Resend count setting out of range	Set the resend count of the request control data of send/receive instructions within a range between 0 and 15 (times).
F7CA	Arrival monitoring time setting out of range	Set the arrival monitoring time of the request control data of send/receive instructions within a range between 0 and 32767 (s).
F7CB	Sent data length setting out of range (SEND instruction)	Set the sent data length of the request control data of the SEND instruction within a range between 1 and 960 (words).

Table 8.1 Error code list (Continued)

Error code	Description	Corrective action
F7CD	System error	The hardware of the network module is faulty. Please consult your local Mitsubishi representative.
F7E1	Control data error	Confirm the set values (mode, etc.) in the control data of a dedicated instruction.
F7E2	System error	The hardware of the network module is faulty.
F7E3	System error	Please consult your local Mitsubishi representative.
F7E4	Target CPU module type error	Check if the CPU module model of the target station specified in the WRITE, READ, REQ, RRUN, RSTOP, RTMRD, and RTMWR instructions is out of applicable range.
F7E5	Post-transmission event wait timer timeout	Re-execute the REMFR or REMTO instruction after a little while. Confirm the operation status of the target station, the network status, and the relay station status (in the case of sending to other network).
F7E7	Buffer memory address error	Check if the buffer memory address specified in the REMFR and REMTO instructions exceeds 8000H.
F7E8	Network type error	Check if the network number specified in the REMFR and REMTO instructions represents a PLC to PLC network.
F7E9	Instruction not executable error	Check if the host station is data-linked when the REMFR or REMTO instruction is executed.
F800	Mode switch setting error	Confirm the setting of the mode switch. If the error reoccurs after resetting, the hardware of the network module is faulty. Please consult your local Mitsubishi representative.
F801	Network number setting error	Create new network parameters and perform Write to PLC.
F802	Group number error	If the error reoccurs, the hardware of the CPU or network module is faulty. Please consult your local Mitsubishi representative.
F803	Station number setting error	Check if the station number is within a range of 1 to 64. If the error reoccurs even if the station number is set between 1 and 64, the hardware of the network module is faulty. Please consult your local Mitsubishi representative.
F804	DIP switch setting error	Create new network parameters and perform Write to PLC. If the error reoccurs, the hardware of the CPU or network module is faulty. Please consult your local Mitsubishi representative.
F805	System error	The hardware of the network module is faulty. Please consult your local Mitsubishi representative.
F806	System error	The hardware of the CPU or network module is faulty. Please consult your local Mitsubishi representative.
F808	System error	The hardware of the network module is faulty. Please consult your local Mitsubishi representative.
F80A	System error	
F80B	System error	
F80C	System error	
F80D	System error	
F80E	System error	
F80F	System error	
F811	System error	
F812	System error	
F813	Parameter data error (parameter)	
F814	Parameter data error (code)	Create new network parameters and perform Write to PLC. If the error reoccurs, the hardware of the CPU or network module is faulty. Please consult your local Mitsubishi representative.

Table 8.1 Error code list (Continued)

Error code	Description	Corrective action
F820	Link parameter error	Replace the network module of the normal station with the one compatible with the MELSECNET/H Extended mode. Change the network type of the normal station to that of the control station. Create new network parameters and perform Write to PLC. If the error reoccurs, the hardware of the CPU or network module is faulty. Please consult your local Mitsubishi representative.
F821	Station-specific parameter error	Review station-specific parameters. Set common parameters \geq station-specific parameters for the sending range of the host station. If no station-specific parameters are set, the hardware of the CPU or network module is faulty. Please consult your local Mitsubishi representative.
F822	System error	The hardware of the CPU or network module is faulty. Please consult your local Mitsubishi representative.
F823	Parameter consistency error	Set common parameters \geq station-specific parameters for the sending range of the host station. If no station-specific parameters are set, the hardware of the CPU or network module is faulty. Please consult your local Mitsubishi representative.
F825	CPU parameter check error	Perform Write to PLC on the network parameters for the control station again. If the error reoccurs, the hardware of the CPU or network module is faulty. Please consult your local Mitsubishi representative.
F826	Parameter mismatch error	Set parameters suitable for the sub control station, or activate it as a control station. Review and reset the parameters for the master and sub master stations. If the error reoccurs, the hardware of the CPU or network module is faulty. Please consult your local Mitsubishi representative.
F828	No control station shift setting	Set "with data link by the sub control station when the control station is down."
F829	Pairing setting error	On the network parameter at control station, set the pairing setting on the Redundant CPU or unset the pairing setting on all the CPUs other than the Redundant CPU.
F82A	Network type mismatch (normal station detected)	Match the network type set for the normal station with the one set for the control station.
F82B	Network type mismatch (control station detected)	
F830	System error	The hardware of the CPU or network module is faulty.
F831	System error	Please consult your local Mitsubishi representative.
F832	Data link startup condition error	If the data link is stopped under all station specification, start it by all station specification. If the data link is stopped under specific station specification, start it from the station, or forcibly start it.
F833	Keyword error	Start the data link from the station where it was discontinued, or forcibly start it.
F834	System error	The cable is faulty, or the hardware of the network module is faulty.
F835	System error	If a communication error has occurred, review the cable.
F836	System error	If not, the hardware of the network module is faulty. Please consult your local Mitsubishi representative.
F837	Exceeded number of retries	Check the status of the control station and of the remote master station (to see if resetting or an error occurs in the middle of the operation).
F838	Relevant timer timeout	Check the status of the control station and of the remote master station (to see if resetting or an error occurs in the middle of the operation).
F839	No link parameter (communication impossible)	Register link parameters
F83A	SW0000 out of range error	Correct the contents of SW0000.

Table 8.1 Error code list (Continued)

Error code	Description	Corrective action
F83B	Forced switching impossible error	Check if the following conditions are met: <ul style="list-style-type: none"> • The system is a multiplexed remote I/O network system. • Check if "Return as a standby station" is set as the parameter for the master station. • The host station is operating as a master station. • The operating sub master station is in data-linking.
F840	Low speed cyclic parameter error	Create new network parameters and perform Write to PLC.
F841	System error	If the error reoccurs, the hardware of the CPU or network module is faulty. Please consult your local Mitsubishi representative.
F842	System error	Create new network parameters and perform Write to PLC. If the error reoccurs, the hardware of the CPU or network module is faulty. Please consult your local Mitsubishi representative.
F843	System error	Create new network parameters and perform Write to PLC. If the error reoccurs, the hardware of the CPU or network module is faulty. Please consult your local Mitsubishi representative.
F901	System error	The hardware of the network module is faulty. Please consult your local Mitsubishi representative.
F902	System error	Check the system configuration to see if there are eight or more relay networks in the MELSECNET/H.
F903	System error	The hardware of the CPU or network module is faulty.
F904	System error	Please consult your local Mitsubishi representative.
F905	System error	The hardware of the network module is faulty. Please consult your local Mitsubishi representative.
FD01	CRC error (offline test)	There is no need to take corrective measures because the system retries the operation. If the error frequently occurs, check for faulty cables, faulty hardware, noise, absence of terminating resistor (in the case of the bus), and incorrect wiring.
FD02	Overrun error (offline test)	
FD03	AB. IF error (offline test)	
FD04	TIME error (offline test)	
FD05	Data error (offline test)	
FD06	Under error (offline test)	
FD07	Send failure	
FD08	Send failure (coaxial bus system)	Check if a coaxial cable is not connected or is loose or faulty and if the terminating resistor is not connected.
FD09	Loop status changed (offline loop test)	There is no need to take corrective measures because the system retries the operation (do not switch the loop in the middle of the operation). If the error frequently occurs, check the line and the wiring status.
FD0A	Unstable communication (offline loop test)	
FD0B	Wiring error (offline loop test)	Check the wiring.
FD0C	System error	There is a problem with the hardware of the network module. Please consult your local Mitsubishi representative.
FD11	Error occurred during test execution	Execute after the completion of the test from other station.
FD12	Disconnecting error	Review the cause for why the station is being disconnected.
FD13	System error	Set the total number of link stations with a common parameter. Set a station number that is equal to the host station number or larger.
FD14	System error	The hardware of the network module is faulty. Please consult your local Mitsubishi representative.
FD15	Send failure	Sending fails on the online test. Check for faulty cables, hardware failure, noise, and incorrect wiring.
FD16	System error	The hardware of the network module is faulty. Please consult your local Mitsubishi representative.
FD17	System error	
FD18	System error	
FD19	System error	
FD1A	Station with duplicated station number	Check the station number and correct it to the number different from that of other stations.
FD1B	Test abort error	The ongoing test was interrupted due to the resetting of the test executing station. There is a faulty station on the networks.

Table 8.1 Error code list (Continued)

Error code	Description	Corrective action
FD1C	Interruption error due to loop switching during test	There is no need to take corrective measures because the system retries the operation (do not switch the loop in the middle of the operation). If the error frequently occurs, check the line and the wiring status.
FD1D	System error	The hardware of the network module is faulty. Please consult your local Mitsubishi representative.
FD1E	Bus topology, test disabled error	Conduct a test that can be executed in the bus topology.
FD20	Mode error	Create new network parameters and perform Write to PLC. If the error reoccurs, the hardware of the CPU or network module is faulty. Please consult your local Mitsubishi representative.
FD21	Hardware error (send interrupt error)	The cable was disconnected during the online test.
FD22	Hardware error (receive interrupt error)	Reconnect the cable, and continue the online test.
FD23	Data comparison error	Check for faulty cables, faulty hardware, incorrect cable wiring, absence of terminating resistor (in the case of the bus), and existence of different communication speeds on the same network. In addition, check whether the same station number has been set for two or more stations or whether two or more control stations exist.
FD24	Retry over	
FD25	Input port initial value check error	The hardware of the network module is faulty. Please consult your local Mitsubishi representative.
FD26	Light check forward side error	There is a problem with the cable.
FD27	Light check reverse side error	Connect a proper cable, and perform an online test.
FD28	RAM check error	
FD29	ROM check error	The hardware of the network module is faulty.
FD2A	Timer function check error	Please consult your local Mitsubishi representative.
FD2B	WDT function check error	
FD31	Online test request error	Wait until a currently-executed online test ends, and execute another online test.
FD32	System error	The hardware of the network module is faulty.
FD33	System error	Please consult your local Mitsubishi representative.
FD35	Response wait timeout occurred	
FD36	Action wait timeout occurred	Retry after a little while.
FD37	Another online test being executed	Check the status of the relevant station and of the line.
FD38	Duplicate message error	
FD39	Communication test request destination error (host station)	Change the test request destination.
FD3A	Communication test request destination error (station to which the test cannot be requested)	A station to which a test request is not available was specified.
FE20	Received data error	Review the routing parameters, or replace the relay CPU module with the AnU or QnA CPU module compatible with the MELECNET/10.
FE21	ZNRD/ZNWR device range error	Review the range of the device to be accessed with the ZNRD/ZNWR instructions to the ACPU.
FE22	AnU request error	Check if access to other station is made from GX Developer with a project of a different CPU type.
FE23	System error	The hardware of the source module starting dedicated instructions and MC protocol is faulty. Please consult your local Mitsubishi representative.
FE24	System error	Confirm the status of the target station and relay station CPU modules. Alternatively, change the CPU module concerned.

Table 8.1 Error code list (Continued)

Error code	Description	Corrective action
FE25	System error	Confirm the power supply status (insufficient voltage, instantaneous interruption, overvoltage, etc.) of the target station for transient transmission and the relay station. Alternatively, change the CPU module concerned.
FE26	System error	Confirm the operation status (WDT error, etc.) of the target station and relay station CPU modules. Alternatively, change the CPU module concerned.
FE27	System error	The hardware of the CPU or network module is faulty. Please consult your local Mitsubishi representative.
FE30	System error	The hardware of the network module is faulty. Please consult your local Mitsubishi representative.
FE31	System error	
FE32	System error	
FE34	System error	
FE36	System error	
FE37	System error	
FE38	System error	
FE39	System error	
FE3B	System error	The hardware of the network module is faulty. Please consult your local Mitsubishi representative.
FE3C	System error	
FE3D	System error	
FE3E	System error	
FE3F	System error	

8.3.3 Error codes detected on remote I/O stations and equivalent to CPU module error codes

The remote I/O station performs some of the same processes as the CPU module. Accordingly, the remote I/O station detects the same error codes*1*2 as in the CPU module.

When an error occurs, the error code, error message or any other information can be read by GX Developer.

For details about operating GX Developer, refer to the GX Developer Operating Manual.

*1 : CPU module error codes are classified into minor, moderate, and major errors as listed below.

- Minor error: Errors that may allow the CPU module to continue the operation, e.g., battery error.
(Error code: 1300 to 10000)
- Moderate error: Errors that may cause the CPU module to stop the operation, e.g., watchdog timer error.
(Error code: 1300 to 10000)
- Major error: Errors that may cause the CPU module to stop the operation, e.g., RAM error.
(Error code: 1000 to 1299)

Determine the error level, i.e. whether the operation can be continued or stopped, by referring to "Operating Statuses of CPU" described in (1) "Error Code List" in this section.

*2 : If any error code not listed in this section is detected, please consult your local Mitsubishi representative.

(1) Error code list

The following table lists the error codes, error messages, error causes, and corrective actions.

Error code (SD0)	Error contents and cause	Corrective action	LED status, Remote I/O operation status
1000	<p>[MAIN CPU DOWN] Runaway or failure of the remote I/O module</p> <ul style="list-style-type: none"> • Malfunction due to noise or other causes • Hardware failure <p>■Collateral information</p> <ul style="list-style-type: none"> • Common Information (SD5 to SD15): - • Individual Information (SD16 to SD26): - <p>■Diagnostic Timing</p> <ul style="list-style-type: none"> • Always 	<ul style="list-style-type: none"> • Take noise reduction measures. • Reset the remote I/O module. <p>If the same error code is displayed again, the cause is a hardware failure of the remote I/O module. (Please consult your local Mitsubishi representative.)</p>	<p>REM: Off ERR: On</p> <p>Remote I/O status: Stop</p>
1005	<p>[MAIN CPU DOWN] Runaway or failure of the remote I/O module</p> <ul style="list-style-type: none"> • Malfunction due to noise or other causes • Hardware failure <p>■Collateral information</p> <ul style="list-style-type: none"> • Common Information (SD5 to SD15): - • Individual Information (SD16 to SD26): - <p>■Diagnostic Timing</p> <ul style="list-style-type: none"> • Always 	<ul style="list-style-type: none"> • Take noise reduction measures. • Reset the remote I/O module. <p>If the same error code is displayed again, the cause is a hardware failure of the remote I/O module. (Please consult your local Mitsubishi representative.)</p>	<p>REM: Off ERR: On</p> <p>Remote I/O status: Stop</p>
1009	<p>[MAIN CPU DOWN]</p> <ul style="list-style-type: none"> • The voltage waveform that is outside the specification is applied to the power supply module, and an error is detected. • A failure was detected on the power supply module, remote I/O module, main base unit, or extension cable. • When using the redundant base unit, the redundant power supply module failure in both systems is detected. <p>■Collateral information</p> <ul style="list-style-type: none"> • Common Information (SD5 to SD15): - • Individual Information (SD16 to SD26): - <p>■Diagnostic Timing</p> <ul style="list-style-type: none"> • Always 	<ul style="list-style-type: none"> • Correct the voltage waveform applied to the power supply module. • Reset the remote I/O module. <p>If the same error code is displayed again, the cause is a hardware failure of the remote I/O module. (Please consult your local Mitsubishi representative.)</p>	<p>REM: Off ERR: On</p> <p>Remote I/O status: Stop</p>
1109	<p>[RAM ERROR] The work area RAM in the remote I/O module is faulty.</p> <p>■Collateral information</p> <ul style="list-style-type: none"> • Common Information (SD5 to SD15): - • Individual Information (SD16 to SD26): - <p>■Diagnostic Timing</p> <ul style="list-style-type: none"> • Always 	<p>The cause is a hardware failure of the remote I/O module. (Please consult your local Mitsubishi representative.)</p>	<p>REM: Off ERR: On</p> <p>Remote I/O status: Stop</p>
1300	<p>[FUSE BREAK OFF] There is an output module with a blown fuse.</p> <p>■Collateral information</p> <ul style="list-style-type: none"> • Common Information (SD5 to SD15): Network No./Station No. • Individual Information (SD16 to SD26): - <p>■Diagnostic Timing</p> <ul style="list-style-type: none"> • Always 	<p>Check the FUSE. LED of the output modules and replace the module whose LED is on. (A blown fuse can be identified using GX Works2 or GX Developer. Check the special register, SD1300 to SD1331, to see if the bit corresponding to the module with a blown fuse is set to "1".)</p>	<p>REM: Off ERR: On</p> <p>Remote I/O status: Stop/Continue*1</p>

Error code (SD0)	Error contents and cause	Corrective action	LED status, Remote I/O operation status
1401	<p>[SP.UNIT DOWN]</p> <ul style="list-style-type: none"> • There was no response from the intelligent function module in the initial processing. • The size of the buffer memory of the intelligent function module is invalid. • The unsupported module is mounted. <p>■Collateral information</p> <ul style="list-style-type: none"> • Common Information (SD5 to SD15): Module No. • Individual Information (SD16 to SD26): - <p>■Diagnostic Timing</p> <ul style="list-style-type: none"> • At power-on/At reset*2/When intelligent function module is accessed 	<p>If an unsupported module is mounted, remove it. When only supported modules are mounted, the cause is a hardware failure of the intelligent function module, remote I/O module, or base unit. (Please consult your local Mitsubishi representative.)</p>	<p>REM: Off ERR: On</p> <p>Remote I/O status: Stop/Continue¹</p>
1403	<p>[SP.UNIT DOWN]</p> <ul style="list-style-type: none"> • There was no response from the intelligent function module. • An error is detected at the intelligent function module. • The I/O module (intelligent function module) is nearly removed, completely removed, or mounted during running. <p>■Collateral information</p> <ul style="list-style-type: none"> • Common Information (SD5 to SD15): Module No. • Individual Information (SD16 to SD26): - <p>■Diagnostic Timing</p> <ul style="list-style-type: none"> • Always 	<p>The cause is a failure of the remote I/O module, base unit, or intelligent function module in the access destination. (Please consult your local Mitsubishi representative.)</p>	<p>REM: Off ERR: On</p> <p>Remote I/O status: Stop/Continue¹</p>
1413	<p>[CONTROL-BUS.ERR.]</p> <p>An error is detected on the system bus.</p> <ul style="list-style-type: none"> • Self-diagnostic error in the system bus • Self-diagnostic error in the remote I/O module <p>■Collateral information</p> <ul style="list-style-type: none"> • Common Information (SD5 to SD15): - • Individual Information (SD16 to SD26): - <p>■Diagnostic Timing</p> <ul style="list-style-type: none"> • Always 	<p>Reset the remote I/O module. If the same error code is displayed again, the cause is a failure of the intelligent function module, remote I/O module, or base unit. (Please consult your local Mitsubishi representative.)</p>	<p>REM: Off ERR: On</p> <p>Remote I/O status: Stop</p>
1414	<p>[CONTROL-BUS.ERR.]</p> <p>An error is detected on the system bus.</p> <p>■Collateral information</p> <ul style="list-style-type: none"> • Common Information (SD5 to SD15): Module No. • Individual Information (SD16 to SD26): - <p>■Diagnostic Timing</p> <ul style="list-style-type: none"> • Always 	<p>Reset the remote I/O module. If the same error code is displayed again, the cause is a failure of the intelligent function module, remote I/O module, or base unit. (Please consult your local Mitsubishi representative.)</p>	<p>REM: Off ERR: On</p> <p>Remote I/O status: Stop</p>
1415	<p>[CONTROL-BUS.ERR.]</p> <p>Fault of the main or extension base unit was detected.</p> <p>■Collateral information</p> <ul style="list-style-type: none"> • Common Information (SD5 to SD15): Base No. • Individual Information (SD16 to SD26): - <p>■Diagnostic Timing</p> <ul style="list-style-type: none"> • Always 	<p>Reset the remote I/O module. If the same error code is displayed again, the cause is a failure of the intelligent function module, remote I/O module, or base unit. (Please consult your local Mitsubishi representative.)</p>	<p>REM: Off ERR: On</p> <p>Remote I/O status: Stop</p>

Error code (SD0)	Error contents and cause	Corrective action	LED status, Remote I/O operation status
1510	<p>[SINGLE PS. DOWN] The power supply voltage of either of redundant power supply modules on the redundant base unit dropped.</p> <p>■Collateral information</p> <ul style="list-style-type: none"> • Common Information (SD5 to SD15): Base No./Power supply No. • Individual Information (SD16 to SD26): - <p>■Diagnostic Timing</p> <ul style="list-style-type: none"> • Always 	Check the power supplied to the redundant power supply modules mounted on the redundant base unit.	<p>REM: Off ERR: On</p> <p>Remote I/O status: Continue</p>
1520	<p>[SINGLE PS. ERROR] On the redundant base unit, the one damaged redundant power supply module was detected.</p> <p>■Collateral information</p> <ul style="list-style-type: none"> • Common Information (SD5 to SD15): Base No./Power supply No. • Individual Information (SD16 to SD26): - <p>■Diagnostic Timing</p> <ul style="list-style-type: none"> • Always 	The cause is a hardware failure of the redundant power supply module. (Please consult your local Mitsubishi representative.)	<p>REM: Off ERR: On</p> <p>Remote I/O status: Continue</p>
1610	<p>[FLSH ROM ERROR] The number of writing to flash ROM (error history) exceeds 100,000 times. (Number of writings > 100,000 times)</p> <p>■Collateral information</p> <ul style="list-style-type: none"> • Common Information (SD5 to SD15): - • Individual Information (SD16 to SD26): - <p>■Diagnostic Timing</p> <ul style="list-style-type: none"> • When writing to ROM 	Change the remote I/O module.	<p>REM: Off ERR: On</p> <p>Remote I/O status: Continue</p>
2000	<p>[UNIT VERIFY ERR.]</p> <ul style="list-style-type: none"> • The I/O module status is different from the I/O module information at power ON. • The I/O module (or intelligent function module) is nearly removed, completely removed, or mounted during running. <p>■Collateral information</p> <ul style="list-style-type: none"> • Common Information (SD5 to SD15): Network No./Station No. • Individual Information (SD16 to SD26): - <p>■Diagnostic Timing</p> <ul style="list-style-type: none"> • Always 	<ul style="list-style-type: none"> • Read common information of the error using GX Works2 or GX Developer to identify the numeric value (module No.). Check the module corresponding to the value and replace it as necessary. • Monitor the special register SD1400 to SD1431 using GX Works2 or GX Developer to identify the module whose data bit is "1". Then check the module and replace it as necessary. 	<p>REM: Off ERR: On</p> <p>Remote I/O status: Stop/Continue¹</p>
2011	<p>[BASE LAY ERROR] The QA1S6□B or QA6□B was used as the base unit.</p> <p>■Collateral information</p> <ul style="list-style-type: none"> • Common Information (SD5 to SD15): Base No. • Individual Information (SD16 to SD26): - <p>■Diagnostic Timing</p> <ul style="list-style-type: none"> • At power-on/At reset² 	Do not use the QA1S6□B or QA6□B as the base unit.	<p>REM: Off ERR: On</p> <p>Remote I/O status: Stop</p>

Error code (SD0)	Error contents and cause	Corrective action	LED status, Remote I/O operation status
2100	<p>[SP. UNIT LAY ERR.]</p> <ul style="list-style-type: none"> In the I/O Assignment tab of the PLC parameter dialog box, "Intelligent" (intelligent function module) is set for the slot where an I/O module is mounted, and vice versa. In the I/O assignment setting of the PLC parameter, switch setting was made to the module that has no switch setting. In the I/O assignment setting of the PLC parameter dialog box, the number of points assigned to the intelligent function module is less than the number of points of the mounted module. <p>[NET/10 mode]</p> <ul style="list-style-type: none"> In the I/O Assignment tab of the PLC parameter dialog box or the I/O assignment setting of the network parameter, "Intelligent" (intelligent function module or special function module) is set for the slot where an I/O module is mounted, and vice versa. In the I/O assignment setting of the PLC parameter, switch setting was made to the module that has no switch setting. In the I/O assignment setting of the PLC parameter dialog box or the I/O assignment setting of the network parameter, the number of points assigned to the intelligent function module (special function module) is less than the number of points of the mounted module. <p>■Collateral information</p> <ul style="list-style-type: none"> Common Information (SD5 to SD15): Module No. Individual Information (SD16 to SD26): - <p>■Diagnostic Timing</p> <ul style="list-style-type: none"> At power-on/At reset² 	<ul style="list-style-type: none"> Set the I/O assignment again so that the setting matches with the mounting status of the intelligent function module or the remote I/O module. Delete the switch setting in the I/O assignment setting of the PLC parameter. <p>[NET/10 mode]</p> <ul style="list-style-type: none"> Set the I/O assignment of the PLC parameter or the I/O assignment of the network parameter again so that the setting matches with the mounting status of the intelligent function module (special function module) or the remote I/O module. Delete the switch setting in the I/O assignment setting of the PLC parameter. 	<p>REM: Off ERR: On</p> <p>Remote I/O status: Stop</p>
2103	<p>[SP.UNIT LAY ERR.]</p> <p>The QI60 is mounted.</p> <p>■Collateral information</p> <ul style="list-style-type: none"> Common Information (SD5 to SD15): Module No. Individual Information (SD16 to SD26): - <p>■Diagnostic Timing</p> <ul style="list-style-type: none"> At power-on/At reset² 	<p>Remove the QI60.</p>	<p>REM: Off ERR: On</p> <p>Remote I/O status: Stop</p>
2106	<p>[SP.UNIT LAY ERR.]</p> <ul style="list-style-type: none"> Five or more Q series Ethernet modules are mounted. 65 or more Q series CC-Link modules are mounted. <p>■Collateral information</p> <ul style="list-style-type: none"> Common Information (SD5 to SD15): Module No. Individual Information (SD16 to SD26): - <p>■Diagnostic Timing</p> <ul style="list-style-type: none"> At power-on/At reset² 	<ul style="list-style-type: none"> Reduce the number of the Q series Ethernet modules to four or less. Reduce the number of the Q series CC-Link modules to 64 or less. 	<p>REM: Off ERR: On</p> <p>Remote I/O status: Stop</p>

Error code (SD0)	Error contents and cause	Corrective action	LED status, Remote I/O operation status
2107	<p>[SP.UNIT LAY ERR.] The start X/Y set in the PLC parameter's I/O assignment settings is overlapped with the one for another module.</p> <p>■Collateral information</p> <ul style="list-style-type: none"> • Common Information (SD5 to SD15): Module No. • Individual Information (SD16 to SD26): - <p>■Diagnostic Timing</p> <ul style="list-style-type: none"> • At power-on/At reset^{*2} 	Configure the I/O assignment setting of the PLC parameter again so that it is consistent with the actual status of the intelligent function modules and I/O modules.	<p>REM: Off ERR: On</p> <p>Remote I/O status: Stop</p>
2121	<p>[SP.UNIT LAY ERR.] The CPU module is mounted on the base unit.</p> <p>■Collateral information</p> <ul style="list-style-type: none"> • Common Information (SD5 to SD15): Module No. • Individual Information (SD16 to SD26): - <p>■Diagnostic Timing</p> <ul style="list-style-type: none"> • At power-on/At reset^{*2} 	Do not install the remote I/O module and CPU module in the same system.	<p>REM: Off ERR: On</p> <p>Remote I/O status: Stop</p>
2122	<p>[SP.UNIT LAY ERR.] The QA1S6□B or QA6□B is used as the main base unit.</p> <p>■Collateral information</p> <ul style="list-style-type: none"> • Common Information (SD5 to SD15): - • Individual Information (SD16 to SD26): - <p>■Diagnostic Timing</p> <ul style="list-style-type: none"> • At power-on/At reset^{*2} 	Replace the main base unit with a usable one.	<p>REM: Off ERR: On</p> <p>Remote I/O status: Stop</p>
2124	<p>[SP.UNIT LAY ERR.]</p> <ul style="list-style-type: none"> • A module is mounted on the 65th slot or later slot. • A module is mounted on the slot whose number is greater than the number of slots specified at [Slots] in [Standard setting] of the base setting. • A module is mounted on the slot whose number of I/O points exceeds 4096 points. • A module is mounted on the slot whose number of I/O points strides 4096 points. <p>■Collateral information</p> <ul style="list-style-type: none"> • Common Information (SD5 to SD15): - • Individual Information (SD16 to SD26): - <p>■Diagnostic Timing</p> <ul style="list-style-type: none"> • At power-on/At reset^{*2} 	<ul style="list-style-type: none"> • Remove the module mounted on the 65th slot or later slot. • Remove the module mounted on the slot whose number is greater than the number of slots specified at [Slots] in [Standard setting] of the base setting. • Remove the module mounted on the slot whose number of I/O points exceeds 4096 points. • Replace the module with the one whose number of occupied points does not exceed 4096 points. 	<p>REM: Off ERR: On</p> <p>Remote I/O status: Stop</p>
2125	<p>[SP.UNIT LAY ERR.]</p> <ul style="list-style-type: none"> • A module which the QCPU cannot recognize has been mounted. • There was no response from the intelligent function module. <p>■Collateral information</p> <ul style="list-style-type: none"> • Common Information (SD5 to SD15): Module No. • Individual Information (SD16 to SD26): - <p>■Diagnostic Timing</p> <ul style="list-style-type: none"> • At power-on/At reset^{*2} 	<ul style="list-style-type: none"> • Mount an applicable module. • The cause is a failure of the intelligent function module. (Please consult your local Mitsubishi representative.) 	<p>REM: Off ERR: On</p> <p>Remote I/O status: Stop</p>

Error code (SD0)	Error contents and cause	Corrective action	LED status, Remote I/O operation status
3000	<p>[PARAMETER ERROR]</p> <ul style="list-style-type: none"> The PLC parameter setting for "Points occupied by empty slot" is outside the range for the remote I/O module. The parameter setting in the individual information of the error (the special register SD16) is invalid. <p>■Collateral information</p> <ul style="list-style-type: none"> Common Information (SD5 to SD15): File name Individual Information (SD16 to SD26): Parameter number <p>■Diagnostic Timing</p> <ul style="list-style-type: none"> At power-on/At reset² 	<ul style="list-style-type: none"> Read the individual information of the error using GX Works2 or GX Developer to identify the numeric value (parameter number). Check the parameters corresponding to the value, and correct them as necessary. Rewrite corrected parameters to the remote I/O module, reload the power supply of the remote I/O module and/or reset the module. If the same error occurs, the cause is a hardware failure. (Please consult your local Mitsubishi representative.) 	<p>REM: Off ERR: On</p> <p>Remote I/O status: Stop</p>
3001	<p>[PARAMETER ERROR]</p> <p>The parameter settings are corrupted.</p> <p>■Collateral information</p> <ul style="list-style-type: none"> Common Information (SD5 to SD15): File name Individual Information (SD16 to SD26): Parameter number <p>■Diagnostic Timing</p> <ul style="list-style-type: none"> At power-on/At reset² 	<ul style="list-style-type: none"> Read the individual information of the error using GX Works2 or GX Developer to identify the numeric value (parameter number). Check the parameters corresponding to the value, and correct them as necessary. Rewrite corrected parameters to the remote I/O module, reload the power supply of the remote I/O module and/or reset the module. If the same error occurs, the cause is a hardware failure. (Please consult your local Mitsubishi representative.) 	<p>REM: Off ERR: On</p> <p>Remote I/O status: Stop</p>
3103	<p>[LINK PARA. ERROR]</p> <ul style="list-style-type: none"> Although one or more Ethernet modules were configured in the Network Parameter dialog box, no Ethernet module is mounted in the system. The start I/O number of the Ethernet network parameter differs from that of the actually mounted module. <p>■Collateral information</p> <ul style="list-style-type: none"> Common Information (SD5 to SD15): File name Individual Information (SD16 to SD26): Parameter number <p>■Diagnostic Timing</p> <ul style="list-style-type: none"> At power-on/At reset² 	<ul style="list-style-type: none"> Correct and write the network parameters. If an error occurs again even after it is corrected, the cause is a hardware failure. (Please consult your local Mitsubishi representative.) 	<p>REM: Off ERR: On</p> <p>Remote I/O status: Stop</p>
3104	<p>[LINK PARA. ERROR]</p> <ul style="list-style-type: none"> The network number, station number or group number set in the network parameter is out of range. The specified I/O number is outside the range of the used remote I/O module. The Ethernet-specific parameter settings are incorrect. <p>■Collateral information</p> <ul style="list-style-type: none"> Common Information (SD5 to SD15): File name Individual Information (SD16 to SD26): Parameter number <p>■Diagnostic Timing</p> <ul style="list-style-type: none"> At power-on/At reset² 	<ul style="list-style-type: none"> Correct and write the network parameters. If an error occurs again even after it is corrected, the cause is a hardware failure. (Please consult your local Mitsubishi representative.) 	<p>REM: Off ERR: On</p> <p>Remote I/O status: Stop</p>

Error code (SD0)	Error contents and cause	Corrective action	LED status, Remote I/O operation status
3105	<p>[LINK PARA. ERROR]</p> <ul style="list-style-type: none"> Although one or more CC-Link modules were configured in the Network Parameter dialog box, no CC-Link module is mounted in the system. The start I/O number in the common parameter differs from that of the actually mounted module. The station type of the CC-Link module network parameter differs from that of the actually mounted station. <p>■Collateral information</p> <ul style="list-style-type: none"> Common Information (SD5 to SD15): File name Individual Information (SD16 to SD26): Parameter number <p>■Diagnostic Timing</p> <ul style="list-style-type: none"> At power-on/At reset^{*2} 	<ul style="list-style-type: none"> Correct and write the network parameters. If an error occurs again even after it is corrected, the cause is a hardware failure. (Please consult your local Mitsubishi representative.) 	<p>REM: Off ERR: On</p> <p>Remote I/O status: Stop</p>
3106	<p>[LINK PARA. ERROR]</p> <p>The network refresh parameter for CC-Link is out of range.</p> <p>■Collateral information</p> <ul style="list-style-type: none"> Common Information (SD5 to SD15): File name Individual Information (SD16 to SD26): Parameter number <p>■Diagnostic Timing</p> <ul style="list-style-type: none"> At power-on/At reset^{*2} 	<p>Check the parameter setting.</p>	<p>REM: Off ERR: On</p> <p>Remote I/O status: Stop</p>
3107	<p>[LINK PARA. ERROR]</p> <ul style="list-style-type: none"> The CC-Link parameter setting is incorrect. The set mode is not allowed for the version of the mounted CC-Link module. <p>■Collateral information</p> <ul style="list-style-type: none"> Common Information (SD5 to SD15): File name Individual Information (SD16 to SD26): Parameter number <p>■Diagnostic Timing</p> <ul style="list-style-type: none"> At power-on/At reset^{*2} 	<p>Check the parameter setting.</p>	<p>REM: Off ERR: On</p> <p>Remote I/O status: Stop</p>
3300	<p>[SP. PARA. ERROR]</p> <p>The start I/O number in the intelligent function module parameter set on GX Works2 or GX Configurator differs from the actual I/O number.</p> <p>■Collateral information</p> <ul style="list-style-type: none"> Common Information (SD5 to SD15): File name Individual Information (SD16 to SD26): Parameter number <p>■Diagnostic Timing</p> <ul style="list-style-type: none"> At power-on/At reset^{*2} 	<p>Check the parameter setting.</p>	<p>REM: Off ERR: On</p> <p>Remote I/O status: Stop</p>

Error code (SD0)	Error contents and cause	Corrective action	LED status, Remote I/O operation status
3301	<p>[SP. PARA. ERROR] The intelligent function module's refresh parameter setting is outside the available range.</p> <p>■Collateral information</p> <ul style="list-style-type: none"> • Common Information (SD5 to SD15): File name • Individual Information (SD16 to SD26): Parameter number <p>■Diagnostic Timing</p> <ul style="list-style-type: none"> • At power-on/At reset*2 	Check the parameter setting.	<p>REM: Off ERR: On</p> <p>Remote I/O status: Stop</p>
3400	<p>[REMOTE PASS. ERR.] The start I/O number of the remote password target module is set to other than 0_H to 0FF0_H.</p> <p>■Collateral information</p> <ul style="list-style-type: none"> • Common Information (SD5 to SD15): - • Individual Information (SD16 to SD26): - <p>■Diagnostic Timing</p> <ul style="list-style-type: none"> • At power-on/At reset*2 	Change the start I/O number of the target module to be within the 0 _H to 0FF0 _H range.	<p>REM: Off ERR: On</p> <p>Remote I/O status: Stop</p>
3401	<p>[REMOTE PASS. ERR.] Any of the following modules is not mounted on the slot specified by the start I/O number of the remote password target module.</p> <ul style="list-style-type: none"> • Serial communication module whose function version B or later • Ethernet module whose function version B or later • Modem interface module whose function version B or later <p>■Collateral information</p> <ul style="list-style-type: none"> • Common Information (SD5 to SD15): - • Individual Information (SD16 to SD26): - <p>■Diagnostic Timing</p> <ul style="list-style-type: none"> • At power-on/At reset*2 	Mount a serial communication module, modem interface module, or Ethernet module whose function version B or later in the specified slot.	<p>REM: Off ERR: On</p> <p>Remote I/O status: Stop</p>

*1: The operation status of the remote I/O station at error occurrence can be set in a parameter.

*2: The remote I/O station can be reset by the following operation.

- Reset the MELSECNET/H remote I/O module.
- Power on the MELSECNET/H remote I/O module.
- Reset, switch from STOP to RUN, or power on the CPU module in the remote master station if the parameters of the remote I/O station are not corrected and the remote I/O station is not reset.
- Reset, switch from STOP to RUN, or power on the CPU module in the remote master station if a stop error exists in the remote I/O station.

8.4 Canceling a Minor Error (Continue Error) on a Remote I/O Station

An error of a remote I/O module can be canceled if it is a type of errors that allows the module operation to continue, as in the case of CPU modules.

The following explains errors that can be canceled and how to cancel them.

(1) Errors that can be canceled

The errors listed below can be canceled.

For error details, refer to Section 8.3.3.

Error code	Error message
1300	FUSE BREAK OFF *1
1401	SP. UNIT DOWN *1
1403	SP. UNIT DOWN *1
1510	SINGLE PS. DOWN
1520	SINGLE PS. ERROR
2000	UNIT VERIFY ERR. *1

*1: Can be canceled only when "Continue" is set in the CPU module on the remote master station and in PLC parameter (Error time operation mode, H/W error time CPU operation mode) for the remote I/O station.

If "Stop" has been selected, the error cannot be canceled because it is regarded as a moderate error (stop error).

(2) How to cancel an error

The following lists how to cancel an error.

Item	Operation	Availability		Reference section
		GX Developer	Sequence program	
Canceling a specific remote I/O station error	Manipulate the remote master station and a remote I/O station to cancel only a specific remote I/O station error.	○	×	8.4.1
Canceling errors of all remote I/O stations	Manipulate the remote master station to cancel errors of all remote I/O stations.	○	○	8.4.2

○: Available ×: N/A

8.4.1 Canceling a specific remote I/O station error

This section explains how to cancel an error of a specific remote I/O station by manipulating the remote master station and the remote I/O station.

(1) Procedures for error cancellation

Use GX Developer and perform the following steps 1) to 7).

[Remote I/O station side]

- 1) Remove the cause of the remote I/O station error.
- 2) Store the error code to be canceled into special register SD50 of the remote I/O module.
- 3) Turn OFF and then ON special relay SM50 of the remote I/O module.
- 4) The error in the remote I/O module is removed.

[Remote master station side]

- 5) Store the error code to be canceled into special register SD50 of the CPU module.
- 6) Turn OFF and then ON special relay SM50 of the CPU module.
- 7) The error in the CPU module is removed.

(2) Precautions for error cancellation

(a) Status after error cancellation

When the error is cancelled, the related special relay, special register and LEDs return to the status before the error occurrence.

If the same error occurs again after error cancellation, it is registered to the error history again.

(b) In the case of the multiplexed remote I/O network that supports redundant systems

After canceling the error in the control system CPU, cancel it in the standby system CPU.

Cancel a standby CPU error by either of the following:

- Using SM50 and SD50 of the standby system CPU
- Using SM1649 and SD1649 of the control system CPU

REMARKS

For detailed error cancellation of the CPU module, refer to the following manuals.

- User's manual (Function Explanation, Program Fundamentals) of the CPU module used
- QnPRHCPU User's Manual (Redundant System)

8.4.2 Canceling errors of all remote I/O stations

This section explains how to manipulate the remote master station to cancel errors of all remote I/O stations.

POINT
<p>(1) For canceling errors of all remote I/O stations, use a master module and remote I/O modules whose serial No. (first five digits) is "08112" or later. For a module whose serial No. (first five digits) is "08111" or earlier, follow the steps described in Section 8.4.1.</p> <p>(2) Errors of all remote I/O stations can be canceled only while the remote master station performs baton (or token) passing (SB0047 is OFF).</p> <p>(3) In multiplexed remote I/O networks (including those supporting redundant systems), this cancel operation is available only from the station acting as a master.</p>

(1) Procedures for error cancellation

Use the sequence program or GX Developer and perform the following steps 1) to 8).

For sample programs, refer to section (3).

[Remote I/O station side]

- 1) Remove the cause of the remote I/O station error.

[Remote master station side]

- 2) Turn ON link special relay SB000F of the master module.
Doing so will cancel errors of all remote I/O stations.
- 3) Check that the master module is in the following status.
<Remote I/O network>
Check that link special relay SB0088 is OFF.
<Multiplexed remote I/O network (including the one that supports redundant systems)>
With link special registers SW0088 to SW008B, check that the bit corresponding to the remote I/O station is 0.
- 4) Turn OFF the link special relay SB000F of the master module.
- 5) The error of the remote I/O module is canceled.
For the blown fuse error or the I/O module verification error, perform steps 6) to 8).
- 6) Store the error code to be canceled into special register SD50 of the CPU module.
- 7) Turn OFF and then ON special relay SM50 of the CPU module.
- 8) The error in the CPU module is canceled.

(2) Precautions for error cancellation

(a) SB000F after error cancellation

Always turn OFF SB000F after canceling an error.

Even if a minor error (continue error) occurs on a remote I/O station while SB000F is ON, the error will not be detected.

(b) Status after error cancellation

When the error is cancelled, the related special relay, special register and LEDs return to the status before the error occurrence.

If the same error occurs again after error cancellation, it is registered to the error history again.

(c) In the case of the multiplexed remote I/O network that supports redundant systems

After canceling the error in the control system CPU, cancel it in the standby system CPU.

To cancel a standby CPU error, use SM1649 and SD1649 of the control system CPU.

REMARKS

For detailed error cancellation of the CPU module, refer to the following manuals.

- User's manual (Function Explanation, Program Fundamentals) of the CPU module used
- QnPRHCPU User's Manual (Redundant System)

(3) Sample programs
 (a) For a remote I/O network

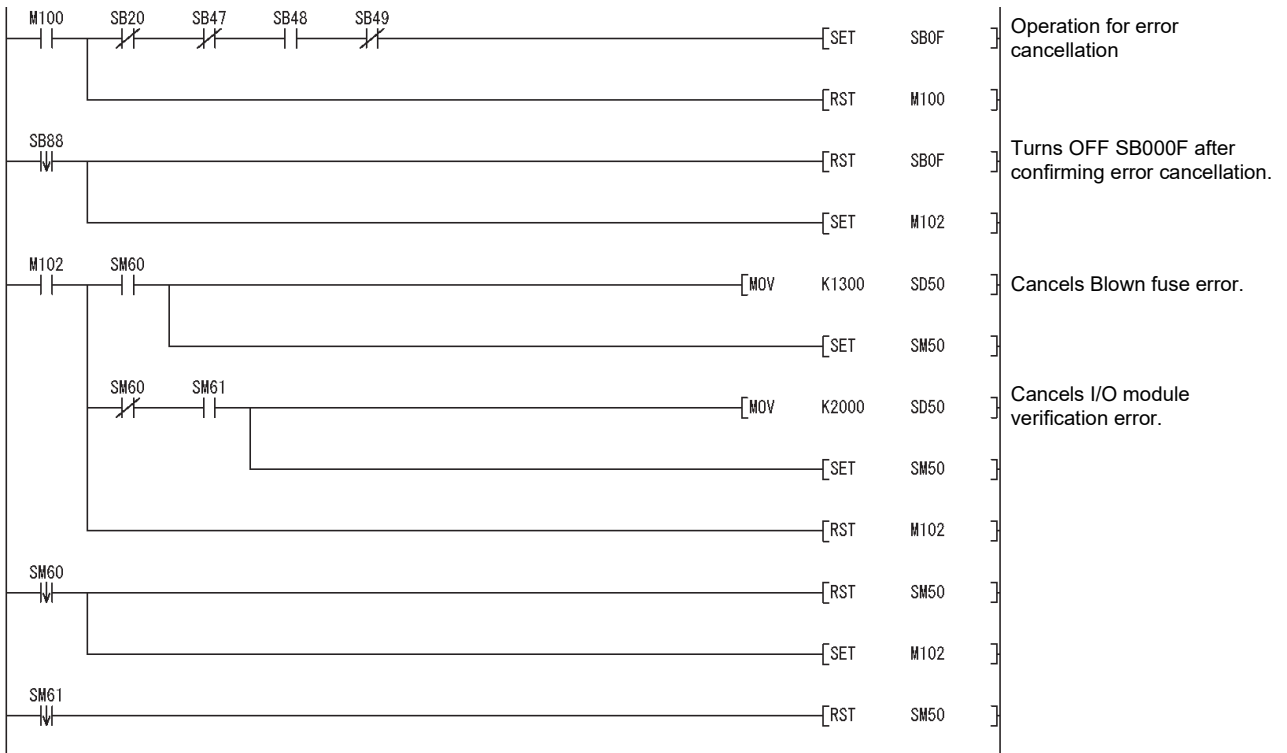

(b) For a multiplexed remote I/O network

The following is a program example used in common to remote master and remote sub-master stations.

Write it to both remote master and remote sub-master stations.

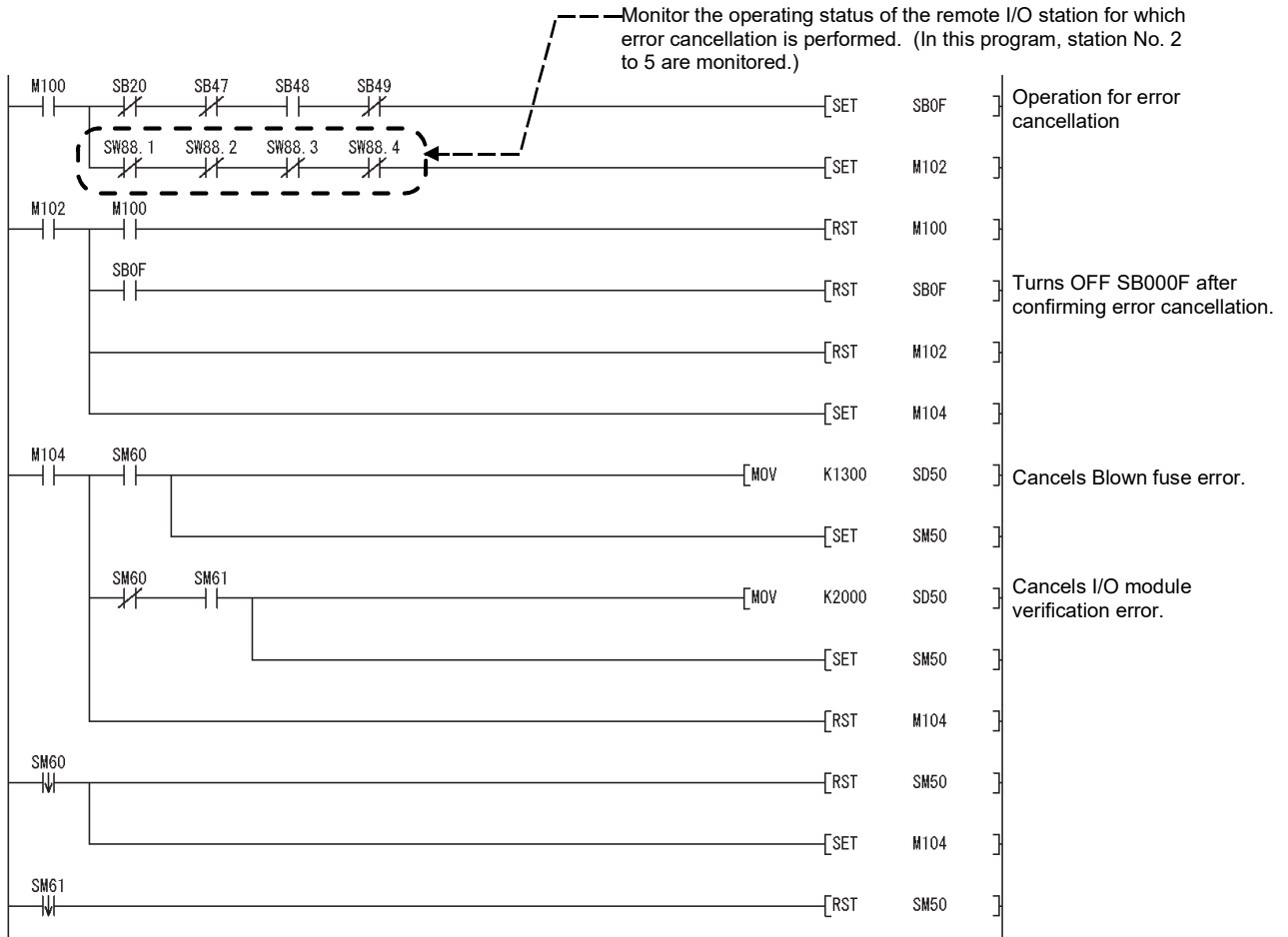

(c) For a multiplexed remote I/O network that supports redundant systems

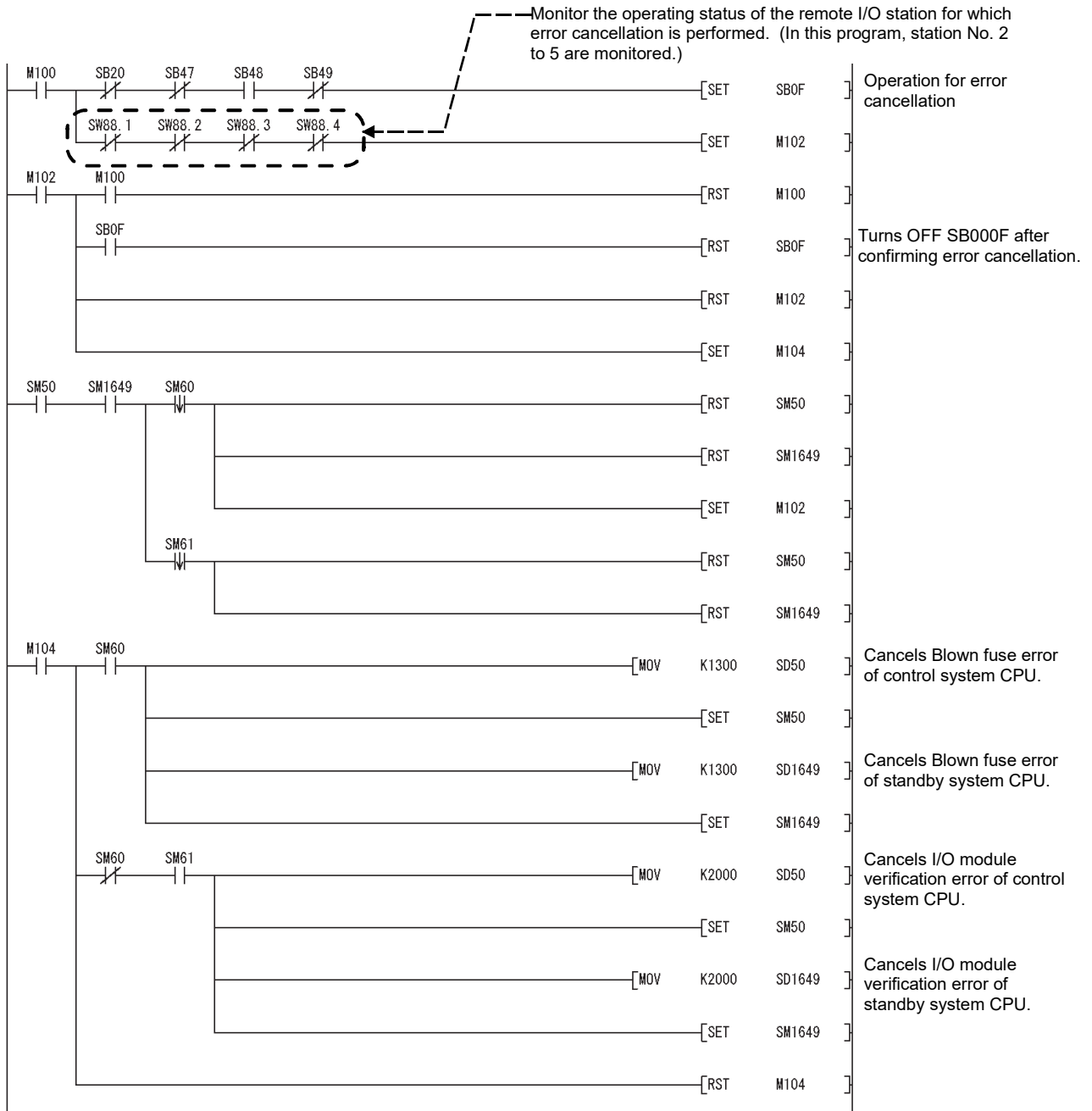

8.5 Procedure for Replacing a Normally Operating Redundant Power Supply Module

This section explains the procedure for replacing a redundant power supply module that is normally operating.

The replacement is available on a remote I/O station without SINGLE PS.DOWN (error code 1510) being detected.

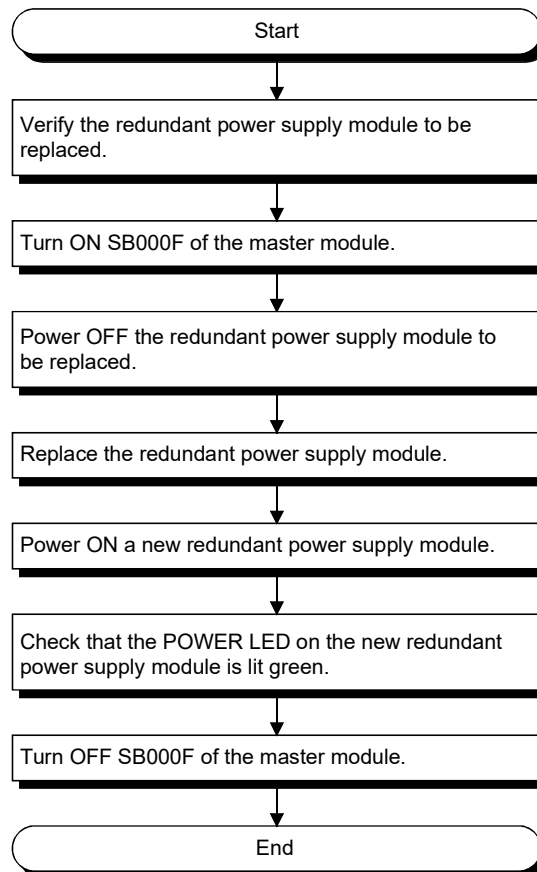
**POINT**

- (1) This replacement procedure is executable when the first five digits of serial No. for the master module and remote I/O modules are "08112" or later.
- (2) This replacement procedure is executable only while the remote master station performs baton (or token) passing (SB0047 is OFF).
- (3) In a multiplexed remote I/O network (including the one that supports redundant systems), SB000F can be manipulated only from the station acting as a master.

8.6 H/W Information

H/W information screen displays details of the LED and switch information of the network modules. To display the H/W information screen, click the H/W information button on the system monitor window of GX Developer.

(1) H/W information on the master module

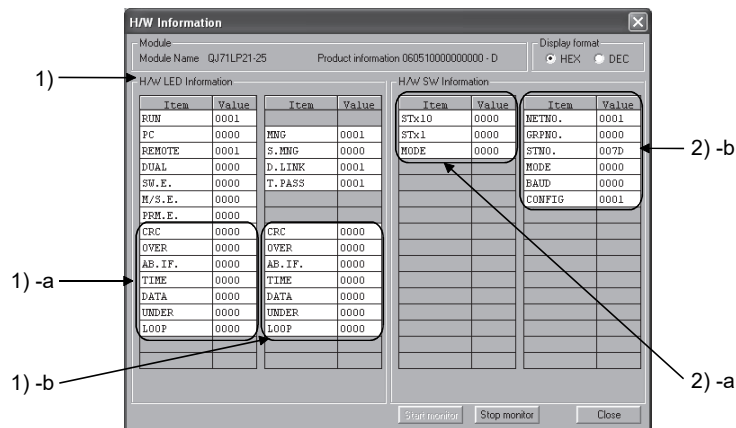

The following explains each of these items.

1) H/W LED information

The following table lists the LED information on the master module.

The value for each item is displayed as: 0001 on, 0000 off.

Item	Description
PC	PLC to PLC network: on
REMOTE	Remote I/O network: on
DUAL	In multiplex transmission: on
SW. E.	Switch setting error: on
M/S. E.	Duplicate station number or remote master station on same network: on
PRM. E.	Parameter error: on
MNG	Remote master station set or multiplexed remote master station performing master operation: on
S. MNG	Multiplexed remote master station performing master operation: on
D. LINK	In data link: on
T. PASS	Baton pass participation: on
CRC	Error during code check of receiving data: on 1)-a: Forward loop 1)-b: Reverse loop
OVER	Error when receive data processing has been delayed: on 1)-a: Forward loop 1)-b: Reverse loop
AB.IF.	Error when "1" over specification is continuously received or when the received data length is short 1)-a: Forward loop 1)-b: Reverse loop
TIME	Error when data link monitor timer has operated: on 1)-a: Forward loop 1)-b: Reverse loop
DATA	Error when error data of 2k-byte or more has been received: on 1)-a: Forward loop 1)-b: Reverse loop
UNDER	Error internal processing of send data is not fixed interval: on 1)-a: Forward loop 1)-b: Reverse loop
LOOP	Error when there is loop error: on 1)-a: Forward loop 1)-b: Reverse loop

(2) H/W switch information

The following tables list the switch setting data for the master module.

2)-a: The switch settings for the hardware mounted to the master module

Item	Description
STx10	10 position of station number setting switch.
STx 1	1 position of station number setting switch.
MODE	Mode setting switch.

2)-b: The switch data that has been actually set on the master module

Item	Description	Display range								
NETNO.	Setting value of network No.	0 to 239								
GRPNO.	Setting value of group number	0 to 9								
STNO.	Setting of station number	1 to 64 (7D _H : remote master station)								
MODE	Setting value of operation mode	0: Online 7: Self loopback-test 8: Internal self- loopback test 9: Hardware test								
BAUD	25 Mbps compatible	0: 10 Mbps 1: 25 Mbps								
CONFIG	Return mode, parameter status setting value	<table border="1" style="margin-left: 20px;"> <tr> <td style="text-align: center;">b15</td> <td style="text-align: center;">b9</td> <td style="text-align: center;">b7</td> <td style="text-align: center;">b0</td> </tr> <tr> <td style="text-align: center;">0</td> <td style="text-align: center;">0</td> <td style="text-align: center;">0</td> <td style="text-align: center;">1</td> </tr> </table> <p style="margin-left: 20px;"> 1: Fixed Return mode 0: Remote master station returns as master operating station (control station). 1: Remote master station returns as sub-master operating station (standby station). Parameter status 0: Without parameters for remote sub-master station 1: With parameters for remote master station/remote sub-master station </p>	b15	b9	b7	b0	0	0	0	1
b15	b9	b7	b0							
0	0	0	1							

(2) H/W information for remote I/O module

Use the following SB/SW to confirm the H/W information of the remote I/O module.

For details, refer to Appendix 2 and Appendix 3.

Setting status of the remote I/O module	SB0040 to 44 SB0058 to 69	SW0040 to 46 SW0054 to 68
Operating status of the remote I/O module	SB0047 to 49	SW0047 to 4A

APPENDICES

Appendix 1 Precautions for Replacing MELSECNET/10 Remote I/O Network with MELSECNET/H Remote I/O Network

This section describes the precautions for replacing MELSECNET/10 remote I/O network for the AnUCPU and QnACPU with MELSECNET/H remote I/O network for the QCPU.

(1) Use of only one type of network module

MELSECNET/H network modules and MELSECNET/10 network modules cannot be used together in a system.

Use only MELSECNET/H remote I/O modules.

Note that if a MELSECNET/H remote I/O module is set in MELSECNET/10 mode, the module is used as a MELSECNET/10 remote I/O station.

(2) Switch settings

The network number setting switches and condition setting switches of MELSECNET/10 network modules do not exist on MELSECNET/H network modules.

Configure these settings in network parameters.

(3) Correction of remote master station network parameters

The network parameters for the remote master station require the corrections described in (2) above.

(4) Setting of parameters to remote I/O station

- The I/O assignment settings set by the network parameters of the MELSECNET/10 remote I/O network master module is set by the remote I/O module PLC parameters on the MELSECNET/H remote I/O network.
- When changing the intelligent function modules mounted to the remote I/O station, there is a need to make switch settings using the remote I/O station PLC parameters. For details, refer to the user's manual for the intelligent function module being used.

(5) Correcting the sequence program

There is no need to change sequence programs such as the interlock program that used link special relays and link special resistors and the remote access program that used data link commands.

However, the data link instructions (ZNFR/ZNTO instructions) used for accessing the buffer memory of the intelligent function module of the remote I/O station and the data link instructions (ZNRD/ZNWR instructions) used for reading/writing of the remote station word device cannot be used on the MELSECNET/H remote I/O network. Accordingly, on the MELSECNET/H, rewrite the ZNFR/ZNTO instructions to REMFR/REMTO instructions and the ZNRD/ZNWR instructions to READ/WRITE instructions.

- The link special relays and link special register operations used in the MELSECNET/10 remote I/O network are the same in the MELSECNET/H network.

(6) Distance between stations using optical fiber cable

When the remote I/O network speed is changed to 25 Mbps, the distance between stations connected by optical fiber cable will become shorter.

Accordingly, the communication speed can either be set to 10 Mbps or another optical fiber cable can be installed.

(7) The multiplex master function has been changed in the following specifications.

Processing when the faulty multiplexed remote master station has returned to system normally:

- The multiplexed remote master station of the MELSECNET/10 cannot participate in a data link if it returns to normal while the remote I/O stations are being controlled by the multiplexed remote sub-master station.
- The multiplexed remote master station of the MELSECNET/H can participate in a data link as the sub-master/master operating station by making parameter setting.

(8) The parallel master function cannot be used since it is not supported.

Appendix 2 Link Special Relay (SB)

The link special relay (SB) turns on/off by various factors that occur during data linking. Thus, by monitoring or using it in the sequence program, the abnormal status of the data link can be checked.

Moreover, the link special relays (SB) that stores the link status are used for the detailed information of the network diagnostics of GX Developer.

For a list of the device numbers for each display item, see Section 8.1 "Network Diagnostics (Network Monitor)" and Section 8.3.1 "How to check error codes"

(1) When multiple network modules are mounted

Data in the link special relay (SB) of each network module are refreshed to the following link special relay (SB) areas of the CPU module when the refresh parameters of each network module are set to their default.

Module mounting position	Module 1	Module 2	Module 3	Module 4
Device number	SB0000 to 01FF	SB0200 to 03FF	SB0400 to 05FF	SB0600 to 07FF

(2) Range turned ON/OFF by user and range turned ON/OFF by system

The link special relay (SB) has the user setting area range (SB0000 to SB001F) and the system setting area range (SB0020 to SB01FF). (The device numbers are the example when the network module is mounted in the position of Module 1.)

(3) List of link special relay (SB) areas

The following lists the link special relay (SB) areas (SB0000 to SB01FF).

POINT
(1) Do not turn ON the area which does not exist in the list. Doing so may cause malfunction of the programmable controller system.
(2) For how to use the link special relay (SB), refer to Section 6.6.

Table 2 Link special relay (SB) list

No.	Name	Description	Availability							
			Control station		Normal station		Remote master station		Remote I/O station	
			Optical	Coaxial	Optical	Coaxial	Optical	Coaxial	Optical	Coaxial
*1 *3 SB0000 (0)	Link startup (host)	Restarts the host's cyclic transmission. Off: Start not instructed On: Start instructed (valid at rise) *2	○	○	○	○	○	○	○	○
*1 *3 SB0001 (1)	Link stop (host)	Stops the host's cyclic transmission. Off: Stop not instructed On: Stop instructed (valid at rise) *2	○	○	○	○	○	○	○	○
*1 *3 SB0002 (2)	System link startup	Restarts the cyclic transmission according to the contents of SW0000 to SW0004. Off: Start not instructed On: Start instructed (valid at rise) *2	○	○	○	○	○	○	○	○
*1 *3 SB0003 (3)	System link stop	Stops the cyclic transmission according to the contents of SW0000 to SW0004. Off: Stop not instructed On: Stop instructed (valid at rise) *2	○	○	○	○	○	○	○	○
SB0005 (5)	Clear retry count	Clears the retry count (SW00C8 to SW00C9) to 0. Off: Clear not instructed On: Clear instructed (valid when on) *2	○	○	○	○	○	○	○	○
*1 SB0006 (6)	Clear communication error count	Clears the communication error (SW00B8 to SW00C7) to 0. Off: Clear not instructed On: Clear instructed (valid when on) *2	○	○	○	○	○	○	○	○

[Availability column] Optical: optical loop, Coaxial: coaxial bus
○: Available, ×: Not available

- * 1: Used in the network tests of peripheral devices.
- * 2: SB0000 to SB0003 become valid when only one point turns on.

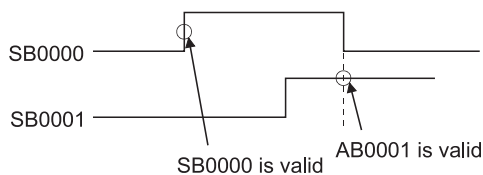

- * 3: Valid only when SB0047 is off. When it turns on (error), the last data are retained.

Table 2 Link special relay (SB) list (Continued)

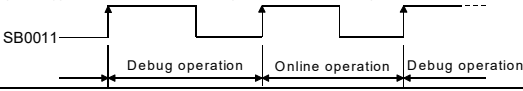
No.	Name	Description	Availability							
			Control station		Normal station		Remote master station		Remote I/O station	
			Optical	Coaxial	Optical	Coaxial	Optical	Coaxial	Optical	Coaxial
SB0007 (7)	Clear forward loop transmission errors	Clears the line abnormal detection (SW00CC) of the forward loop side to 0. Off: Clear not instructed On: Clear instructed (valid when on)	○	×	○	×	○	×	○	×
SB0008 (8)	Clear reverse loop transmission errors	Clears the line abnormal detection (SW00CD) of the reverse loop side to 0. Off: Clear not instructed On: Clear instructed (valid when on)	○	×	○	×	○	×	○	×
*6 SB0009 (9)	Clear loop switch count	Clears the loop switch count (SW00CE to SW00E7) to 0. Off: Clear not instructed On: Clear instructed (valid when on)	○	×	○	×	○	×	○	×
SB000A (10)	Clear transient transmission errors	Clears the transient transmission errors (SW00EE, SW00EF) to 0. Off: Clear not instructed On: Clear instructed (valid when on)	○	○	○	○	○	○	○	○
SB000B (11)	Transient transmission error area setting	Designates whether to overwrite or retain the transient transmission errors (SW00F0 to SW00FF). Off: Overwrite On: Retain	○	○	○	○	○	○	○	○
*3*4 SB000F (15)	Clear minor errors	Clears all of minor errors detected by remote I/O stations. This error clear is executed on all remote I/O stations. While SB000F is ON, no minor error is detected on all remote I/O stations. In a multiplexed remote I/O network (including the one that supports redundant systems), this can be manipulated only from the station acting as a master. Off: Clear not instructed On: Clear instructed (valid when on)	×	×	×	×	○	○	×	×
SB0011 (17)	Data link operation designation	Designates the data link operation. Off: No switch instruction On: Switch instruction (valid when on) When On is detected, data link switches from Online (normal data link) operation to Online (debug) operation, or from Online (debug) operation to Online (normal operation). 	○	○	○	○	○	○	○	○
SB0014 (20)	Remote sub-master station switching command	Forcibly directs the remote sub-master station that is performing master operation to shift to sub-master operation. (It is invalid for the redundant system.) Off: Without directive On: With directive	×	×	×	×	○	○	×	×
SB0018 (24)	System switching monitoring time setting valid flag	Indicates whether the system switching monitoring time setting (SW0018) is valid or invalid in case of a data link error. Off: Invalid On: Valid (valid at the time of startup)	○	○	○	○	○	○	×	×
SB0020 (32)	Module status	Indicates the communication status between the network module and the CPU module. Off: Normal On: Abnormal	○	○	○	○	○	○	×	×
SB0040 (64)	Network type (host)	Indicates the network type set with the parameters of the host's network module. Off: PLC to PLC network On: Remote I/O network	○	○	○	○	○	○	○	○
SB0041 (65)	Host station's redundant function support information	Indicates the station supports the redundant function or not. Off: Redundant function not supported On: Redundant function supported	○	○	○	○	○	○	○	○
SB0042 (66)	Power supply status of host	Indicates the external power supply status to the host's QJ71LP21S-25. (When using QJ71LP21-25, 0 is ON.) Off: Not supplied (EXT.PW LED is OFF.) On: Supplied (EXT.PW LED is ON.)	○	×	○	×	○	×	○	×
SB0043 (67)	Online switch (host)	Indicates the mode set by the switch of the host's network module. Off: Online (mode setting is 0 or 4); "Parameter setting mode becomes valid" On: Other than online (mode setting is other than 0)	○	○	○	○	○	○	○	○

* 3: Valid only when SB0047 is off. When it turns on (error), the last data are retained.
 * 4: Minor errors are the type of errors that do not affect the CPU operation. (Refer to Section 8.3.3)
 * 6: The SB0009 should be kept on until the SW00CE becomes "0."

Table 2 Link special relay (SB) list (Continued)

No.	Name	Description	Availability							
			Control station		Normal station		Remote master station		Remote I/O station	
			Optical	Coaxial	Optical	Coaxial	Optical	Coaxial	Optical	Coaxial
SB0044 (68)	Station setting (host)	When PLC to PLC network Indicates the station type set with the parameter of the host's network module. Off: Normal station On: Control station	○	○	○	○	×	×	×	×
		When remote I/O network Indicates the station type set with the parameter of the host's network module. Off: Remote I/O station or multiplexed remote sub-master station On: Remote master station or multiplexed remote master station	×	×	×	×	○	○	○	○
SB0045 (69)	Setting information (host)	Indicates the switch setting information (including parameter settings) of the host's network module. Off: Normal On: Abnormal setting	○	○	○	○	○	○	○	○
SB0046 (70)	Data link operation designation result (host)	Indicates the switch setting information (including parameter settings) of the host's network module. Off: Normal data linking On: Operating in debug mode	○	○	○	○	○	○	○	○
SB0047 (71)	Baton pass status (host)	Indicates the host's baton pass status (transient transmission enabled). Off: Normal On: Abnormal When an error is identified, the cause of the error can be checked in Baton pass status (host) (SW0047) and Cause of baton pass interruption (SW0048).	○	○	○	○	○	○	○	○
* 3 SB0048 (72)	Control station status (host)	When PLC to PLC network Indicates the host's status. Off: Normal station On: Control station (SB0044 is on) Sub-control station (SB0044 is off)	○	○	○	○	×	×	×	×
	Remote master station status (host)	When remote I/O network Indicate the host status Off: Remote I/O station On: SB0044=On Remote master station or multiplexed remote master station SB0044=Off Remote I/O station or multiplexed remote sub-master station	×	×	×	×	○	○	○	○
SB0049 (73)	Host data link status	Indicates the host's data link operation status. Off: Normal On: Abnormal When an error is identified, the cause of the error can be checked in Cause of data link stop (SW0049).	○	○	○	○	○	○	○	○
* 4 SB004A (74)	Host CPU status (1)	Indicates the host's CPU status. Off: Normal On: Minor error occurred	○	○	○	○	○	○	×	×
* 5 SB004B (75)	Host CPU status (2)	Indicates the host's CPU status. Off: Normal On: A serious or fatal error occurred	○	○	○	○	○	○	×	×
* 3 SB004C (76)	Cyclic transmission start acknowledgment status (host)	Indicates the startup acknowledgment status of the cyclic transmission. Off: Not acknowledged (SB0000 is off) On: Start acknowledged (SB0000 is on)	○	○	○	○	○	○	○	○
* 3 SB004D (77)	Cyclic transmission start completion status (host)	Indicates the completion status of the cyclic transmission. Off: Not completed (SB0000 is off) On: Start completed (SB0000 is on)	○	○	○	○	○	○	○	○
* 3 SB004E (78)	Cyclic transmission stop acknowledgment status (host)	Indicates the stop acknowledgment status of the cyclic transmission. Off: Not acknowledged (SB0001 is off) On: Stop acknowledged (SB0001 is on)	○	○	○	○	○	○	○	○
* 3 SB004F (79)	Cyclic transmission stop completion status (host)	Indicates the stop completion status of the cyclic transmission. Off: Not completed (SB0001 is off) On: Stop completed (SB0001 is on)	○	○	○	○	○	○	○	○

* 3: Valid only when SB0047 is off. When it turns on (error), the last data are retained.
 * 4: Minor errors are the type of errors that do not affect the CPU operation. (Refer to Section 8.3.3)
 * 5: Serious errors are the type of errors that stop the CPU operation.
 Fatal errors are also the type of errors that stop the CPU operation. (Refer to Section 8.3.3)

Table 2 Link special relay (SB) list (Continued)

No.	Name	Description	Availability									
			Control station		Normal station		Remote master station		Remote I/O station			
			Optical	Coaxial	Optical	Coaxial	Optical	Coaxial	Optical	Coaxial		
* 3 SB0050 (80)	Cyclic transmission start acknowledgment status (system)	Indicates the startup acknowledgment status of the cyclic transmission. Off: Not acknowledged (SB0002 is off) On: Start acknowledged (SB0002 is on)	○	○	○	○	○	○	○	○	○	○
* 3 SB0051 (81)	Cyclic transmission start completion status (system)	Indicates the completion status of the cyclic transmission. Off: Not completed (SB0002 is off) On: Start completed (SB0002 is on)	○	○	○	○	○	○	○	○	○	○
* 3 SB0052 (82)	Cyclic transmission stop acknowledgment status (system)	Indicates the stop acknowledgment status of the cyclic transmission. Off: Not acknowledged (SB0003 is off) On: Stop acknowledged (SB0003 is on)	○	○	○	○	○	○	○	○	○	○
* 3 SB0053 (83)	Cyclic transmission stop completion status (system)	Indicates the stop completion status of the cyclic transmission. Off: Not completed (SB0003 is off) On: Stop completed (SB0003 is on)	○	○	○	○	○	○	○	○	○	○
SB0054 (84)	Parameter receive status	Indicates the parameter receive status. Off: Receive completed On: Not received	○	○	○	○	○	○	○	○	○	○
SB0055 (85)	Received parameter error	Indicates the status of the received parameters. Off: Parameters normal On: Parameters abnormal	○	○	○	○	○	○	○	○	○	○
* 3 SB0056 (86)	Communication status	Indicates the status of the transient transmission Off: Transient transmission by the control station On: Transient transmission by the sub-control station	○	○	○	○	○	○	○	○	○	○
SB0057 (87)	Parameter type	Indicates the parameter type. Off: MELSECNET/10 parameter On: MELSECNET/H parameter	○	○	○	○	○	○	○	○	○	○
SB0058 (88)	Operation designation at fault of control station	On PLC to PLC network Indicates the setting of "With data link by sub control station when control station is down." Off: Cyclic transmission made by sub control station when control station fails. On: Cyclic transmission not made by sub control station when control station becomes faulty	○	○	○	○	×	×	×	×	×	×
	Operation designation at fault of (multiplexed) remote master station	On remote I/O network Indicates the status of designating cyclic transmission when the (multiplexed) remote master station fails. Off: Cyclic transmission made by multiplexed remote sub-master station when multiplexed remote master station fails (multiplexed remote I/O network) On: Cyclic transmission not made when remote master station fails (remote I/O network)	×	×	×	×	○	○	○	○	○	○
SB0059 (89)	Low-speed cyclic designation	Indicates whether or not there are any parameter settings for the low-speed cyclic transmission. Off: No settings On: Settings exist	○	○	○	○	○	○	○	○	○	○
SB005A (90)	Parameter type 2	Indicates the parameter type of the control station. Off: MELSECNET/10 mode, MELSECNET/H mode On: MELSECNET/H Extended mode	○	○	○	○	×	×	×	×	×	×
SB005B (91)	END asynchronous settings	Indicates the END asynchronous settings status of the remote I/O network. Off: END asynchronous settings disabled On: END asynchronous settings enabled	×	×	×	×	○	○	×	×	×	×
SB005C (92)	I/O master station (Block 1)	Indicates the I/O master station setting (Common parameter setting) of block 1. (Valid when SB0049 is OFF) Off: No setting On: Setting exists. (Station No. is stored in SW005C.)	○	○	○	○	×	×	×	×	×	×
SB005D (93)	I/O master station (Block 2)	Indicates the I/O master station setting (Common parameter setting) of block 2. (Valid when SB0049 is OFF) Off: No setting On: Setting exists. (Station No. is stored in SW005D.)	○	○	○	○	×	×	×	×	×	×

* 3: Valid only when SB0047 is off. When it turns on (error), the last data are retained.

Table 2 Link special relay (SB) list (Continued)

No.	Name	Description	Availability							
			Control station		Normal station		Remote master station		Remote I/O station	
			Optical	Coaxial	Optical	Coaxial	Optical	Coaxial	Optical	Coaxial
SB0064 (100)	Reserved station designation	Indicates whether or not the station is reserved. (Valid when the SB0049 is off.) Off: No reserved station On: Reserved station exists If a reserved station is found, the status of each station can be checked by Reserved station designation (SW0064 to SW0067). Depending on the timing of the link refresh, Reserved station designation (SW0064 to SW0067) and the update may be offset by one sequence scan.	○	○	○	○	○	○	○	○
SB0068 (104)	Communication mode	Indicates the link scan mode (status of supplementary settings of the common parameters). (Valid when the SB0049 is off.) Off: Normal mode On: Constant scan mode	○	○	○	○	○	○	○	○
SB0069 (105)	Multiplex transmission designation	Indicates the transmission designation status (status of supplementary settings of the common parameters). (Valid when the SB0049 is off.) Off: Normal transmission designation On: Multiplex transmission designation	○	×	○	×	○	×	○	×
*3 SB006A (106)	Multiplex transmission status	Indicates the transmission status. Off: Normal transmission On: Multiplex transmission In the case of multiplex transmission, the status of each station can be checked in Multiplex transmission status (1) (SW00B0 to SW00B3) and (2) (SW00B4 to SW00B7).	○	×	○	×	○	×	○	×
*3 SB006B (107)	Multiplex remote function designation	Indicates the status of designating the multiplex remote function. Off: Not designated. On: Designated.	×	×	×	×	○	○	○	○
*3 SB0070 (112)	Baton pass status of each station	Indicates the baton pass status of each station. (Not applicable to reserved stations and the station with the maximum station number or higher) Off: All stations normal On: Faulty station exists When any faulty station exists, each station status can be checked in Baton pass status of each station (SW0070 to SW0073). Depending on the timing of the link refresh, Baton pass status of each station (SW0070 to SW0073) and the update may be offset by one sequence scan.	○	○	○	○	○	○	○	○
*3 SB0071 (113)	Baton pass status of the remote master station	Indicates the baton pass status of the master station. (Including when there is an online loop test.) Off: Master station baton pass normal. On: Master station baton pass error.	×	×	×	×	○	○	○	○
*3 SB0072 (114)	Remote sub-master station transient transmission status	Indicates the transient transmission status of the remote sub-master station. Off: Normal On: Abnormal	×	×	×	×	○	○	○	○
*3 SB0074 (116)	Cyclic transmission status of each station	Indicates the cyclic transmission status of each station. (Not applicable to reserved stations and the station with the maximum station number or higher) Off: All stations are executing data linking On: Stations that are not executing data linking exist When any non-executing station exists, each station status can be checked in Cyclic transmission status of each station (SW0074 to SW0077). Depending on the timing of the link refresh, Cyclic transmission status of each station (SW0074 to SW0077) and the update may be offset by one sequence scan.	○	○	○	○	○	○	○	○
*3 SB0075 (117)	Cyclic transmission status of the remote master station	Indicates the master station cyclic transmission status. (Includes online loop test.) Off: Master station cyclic transmission normal. On: Master station cyclic transmission error.	×	×	×	×	○	○	○	○

* 3: Valid only when SB0047 is off. When it turns on (error), the last data are retained.

Table 2 Link special relay (SB) list (Continued)

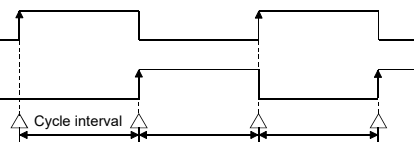
No.	Name	Description	Availability							
			Control station		Normal station		Remote master station		Remote I/O station	
			Optical	Coaxial	Optical	Coaxial	Optical	Coaxial	Optical	Coaxial
*3 SB0076 (118)	Remote sub-master station cyclic transmission status	Indicates the cyclic transmission status of the remote sub-master station. (Including the status at an online loop test) Off: Cyclic transmission normal On: Cyclic transmission abnormal	×	×	×	×	○	○	○	○
*3 SB0077 (119)	Remote master station cyclic transmission control status	Indicates the station type that is controlling cyclic transmission at the remote I/O stations. Off: Remote master station On: Remote sub-master station	×	×	×	×	○	○	○	○
*3 SB0078 (120)	Parameter communication status of each station	Indicates the parameter transmission status of each station. (Not applicable to reserved stations and the station with the maximum station number or higher) Off: Executing communication other than parameter communication On: Executing parameter communication Stations that are communicating parameters can be checked in Parameter communication status of each station (SW0078 to SW007B). Depending on the timing of the link refresh, Parameter communication status of each station (SW0078 to SW007B) and the update may be offset by one sequence scan.	○	○	×	×	○	○	×	×
*3 SB007A (122)	Low-speed cyclic communication status	Indicates the low-speed cycle communication status. It is indicated to have transmitted by turning the bit on for either the SB007A or SB007B. 	○	○	○	○	×	×	×	×
*3 SB007B (123)			○	○	○	○	×	×	×	×
*3 SB007C (124)	Parameter status of each station	Indicates the parameter status of each station. (Not applicable to reserved stations and the station with the maximum station number and higher) Off: No station detected parameter errors On: A station detected parameter errors Stations that have parameter errors can be checked in Parameter error status of each station (SW007C to SW007F). Depending on the timing of the link refresh, Parameter error status of each station (SW007C to SW007F) and the update may be offset by one sequence scan.	○	○	×	×	○	○	×	×
*3 *5 SB0080 (128)	CPU operation status of each station (1)	Indicates the operation status of each station's CPU on the PLC-to-PLC network (including the host station). Off: All stations normal On: A moderate or serious error identified If a moderate or serious error is identified, the status of each station can be checked in CPU operation status of each station (1) (SW0080 to SW0083). Depending on the timing of the link refresh, CPU operation status of each station (1) (SW0080 to SW0083) and the update may be offset by one sequence scan.	○	○	○	○	×	×	×	×
			Indicates the operation status of each remote I/O station on the remote I/O network (including the host station). Off: All stations normal On: Error station identified If any error station is identified, the status of each station can be checked in CPU operation status of each station (1) (SW0080 to SW0083). Depending on the timing of the link refresh, CPU operation status of each station (1) (SW0080 to SW0083) and the update may be offset by one sequence scan.	×	×	×	×	○	○	○

*3: Valid only when SB0047 is off. When it turns on (error), the last data are retained.

*5: Serious errors are the type of errors that stop the CPU operation.

Fatal errors are also the type of errors that stop the CPU operation. (Refer to Section 8.3.3.)

Table 2 Link special relay (SB) list (Continued)

No.	Name	Description	Availability							
			Control station		Normal station		Remote master station		Remote I/O station	
			Optical	Coaxial	Optical	Coaxial	Optical	Coaxial	Optical	Coaxial
*3 SB0084 (132)	CPU RUN status of each station	Indicates the CPU RUN status of each station. Off: All stations are in the RUN or STEP RUN status On: Stations in the STOP or PAUSE status exist (including the host) When some stations are in the STOP or PAUSE status, each station status can be checked in CPU RUN status of each station (SW0084 to SW0087). Depending on the timing of the link refresh, CPU RUN status of each station (SW0084 to SW0087) and the update may be offset by one sequence scan.	○	○	○	○	×	×	×	×
*3 SB0085 (133)	CPU RUN status of the remote master station	Indicates the CPU run status of remote master station. Off: Run or STEP RUN status On: STOP or PAUSE status	×	×	×	×	○	○	○	○
*3 SB0086 (134)	Remote sub-master station CPU RUN status	Indicates the CPU status of the multiplexed remote sub-master station. Off: RUN or STEP RUN status On: STOP or PAUSE status	×	×	×	×	○	○	○	○
*3 *4 SB0088 (136)	CPU operation status of each station (2)	Indicates the operation status of each station's CPU or of each remote I/O station (including the host station). Off: All stations normal On: Stations with minor errors exist If any station with a minor error exists, the status of each station can be checked in CPU operation status of each station (2) (SW0088 to SW008B). Depending on the timing of the link refresh, CPU operation status of each station (2) (SW0088 to SW008B) and the update may be offset by one sequence scan.	○	○	○	○	○	○	○	○
*3 SB008C (140)	External power supply information	Indicates the information of the external power supply (including the host). Off: All stations are without external power supply On: Stations with external power supply exist When any station with external power supply exists, the status of each station can be checked in Power supply status of each station (SW008C to SW008F). Depending on the timing of the link refresh, Power supply status of each station (SW008C to SW008F) and the update may be offset by one sequence scan.	○	×	○	×	○	×	○	×
*3 SB008D (141)	Module type of each station	Indicates the module type of each station. Off: NET/10H type modules exist On: All stations are NET/H type modules	○	○	○	○	×	×	×	×
SB0090 (144)	Host loop status	Indicates the host's loop status. Off: Normal On: Abnormal When an error is identified, the error details can be checked by Loopback information (SW0090).	○	×	○	×	○	×	○	×
*3 SB0091 (145)	Forward loop status	Indicates the status of stations connected to the forward loop. Off: All stations normal On: Faulty stations exist When any faulty station exists, the status of each station can be checked in Forward loop status of each station (SW0091 to SW0094). Depending on the timing of the link refresh, Forward loop status of each station (SW0091 to SW0094) and the update may be offset by one sequence scan.	○	×	○	×	○	×	○	×
*3 SB0092 (146)	Forward loop status of remote master station	Indicates the forward loop status of the remote master station. Off: Normal On: Error	×	×	×	×	×	×	*6 ○	×

*3: Valid only when SB0047 is off. When it turns on (error), the last data are retained.

*4: Minor errors are the type of errors that do not affect the CPU operation. (Refer to Section 8.3.3)

*6: Available only in the remote sub-master station.

Table 2 Link special relay (SB) list (Continued)

No.	Name	Description	Availability								
			Control station		Normal station		Remote master station		Remote I/O station		
			Optical	Coaxial	Optical	Coaxial	Optical	Coaxial	Optical	Coaxial	
*3 SB0095 (149)	Reverse loop status	Indicates the status of stations connected to the reverse loop. Off: All stations normal On: Faulty stations exist When any faulty station exists, the status of each station can be checked in Reverse loop status of each station (SW0095 to SW0098). Depending on the timing of the link refresh, Reverse loop status of each station (SW0095 to SW0098) and the update may be offset by one sequence scan.	○	×	○	×	×	×	○	×	
*3 SB0096 (150)	Reverse loop status of remote master station	Indicates the reverse loop status of the remote master station. Off: Normal On: Error	×	×	×	×	×	×	○	×	
*3 SB0099 (153)	Forward loop loopback	Indicates the loopback status of the forward loop while the system is operating. Off: Not executed On: Executing stations exist (Executing stations are stored in the SW0099)	○	×	○	×	○	×	○	×	
*3 SB009A (154)	Reverse loop loopback	Indicates the loopback status of the reverse loop while the system is operating. Off: Not executed On: Executing stations exist (Executing stations are stored in the SW009A)	○	×	○	×	○	×	○	×	
*3 SB009C (156)	Send transmission path mismatch status	Indicates the status of the transmission path used for sending by other stations. Off: All matched On: Mismatching stations exist Depending on the timing of the link refresh, Loop usage status of each station (SW009C to SW009F) and the update may be offset by one sequence scan.	○	×	○	×	×	*6	×	○	×
*3 SB00A0 (160)	RECV instruction execution request flag (1)	Stores the data reception status of channel 1 of the host station. Off: No data reception On: Data received	○	○	○	○	×	×	×	×	
*3 SB00A1 (161)	RECV instruction execution request flag (2)	Stores the data reception status of channel 2 of the host station. Off: No data reception On: Data received	○	○	○	○	×	×	×	×	
*3 SB00A2 (162)	RECV instruction execution request flag (3)	Stores the data reception status of channel 3 of the host station. Off: No data reception On: Data received	○	○	○	○	×	×	×	×	
*3 SB00A3 (163)	RECV instruction execution request flag (4)	Stores the data reception status of channel 4 of the host station. Off: No data reception On: Data received	○	○	○	○	×	×	×	×	
*3 SB00A4 (164)	RECV instruction execution request flag (5)	Stores the data reception status of channel 5 of the host station. Off: No data reception On: Data received	○	○	○	○	×	×	×	×	
*3 SB00A5 (165)	RECV instruction execution request flag (6)	Stores the data reception status of channel 6 of the host station. Off: No data reception On: Data received	○	○	○	○	×	×	×	×	
*3 SB00A6 (166)	RECV instruction execution request flag (7)	Stores the data reception status of channel 7 of the host station. Off: No data reception On: Data received	○	○	○	○	×	×	×	×	
*3 SB00A7 (167)	RECV instruction execution request flag (8)	Stores the data reception status of channel 8 of the host station. Off: No data reception On: Data received	○	○	○	○	×	×	×	×	
SB00A8 (168)	Online test instruction	Indicates the online test instruction status. Off: Not instructed On: Instructed	○	○	○	○	○	○	○	○	

*3: Valid only when SB0047 is off. When it turns on (error), the last data are retained.

*6: Available only in the remote sub-master station.

Table 2 Link special relay (SB) list (Continued)

No.	Name	Description	Availability								
			Control station		Normal station		Remote master station		Remote I/O station		
			Optical	Coaxial	Optical	Coaxial	Optical	Coaxial	Optical	Coaxial	
SB00A9 (169)	Online test completion	Indicates the online test completion status. Off: Not completed On: Completed If "Completed" is indicated, the online test information can be obtained in Online test execution item/faulty station (requesting side) (SW00A8) and Online test result (requesting side) (SW00A9).	○	○	○	○	○	○	○	○	○
SB00AA (170)	Online test response instruction	Indicates the online test response status. Off: No response On: Responded	○	○	○	○	○	○	○	○	○
SB00AB (171)	Online test response completion	Indicates the online test response completion status. Off: Response not completed On: Response completed If "Response completed" is indicated, the online test information can be obtained in Online test execution item/faulty station (responding side) (SW00AA) and Online test result (responding side) (SW00AB).	○	○	○	○	○	○	○	○	○
SB00AC (172)	Offline test instruction	Indicates the offline test instruction status. Off: Not instructed On: Instructed	○	○	○	○	○	○	○	○	○
SB00AD (173)	Offline test completion	Indicates the offline test completion status. Off: Not completed On: Completed If "Completed" is indicated, the offline test information can be obtained in Offline test execution item/faulty station (requesting side) (SW00AC) and Offline test result (requesting side) (SW00AD).	○	○	○	○	○	○	○	○	○
SB00AE (174)	Offline test response	Indicates the response status for offline test. Off: No response On: Response	○	○	○	○	○	○	○	○	○
SB00AF (175)	Offline test response completion	Indicates the response status for offline test end. Off: Response not completed On: Response completed If "Response completed" is indicated, the offline test information can be obtained in Offline test execution item (responding side) (SW00AE) and Offline test result (responding side) (SW00AF).	○	○	○	○	○	○	○	○	○
SB00EE (238)	Transient error	Indicates the transient transmission error status. Off: No error On: Errors exist	○	○	○	○	○	○	○	○	○
*3 SB01C4 (452)	Remote sub-master station switching acceptance status	Indicates the status of accepting the directive to shift from master operation to sub-master operation. Off: Without acceptance On: With acceptance	×	×	×	×	○	○	×	×	×
*3 SB01C5 (453)	Remote sub-master station switching status	Indicates the operation status of a shift from master operation to sub-master operation. Off: Without shift On: Shift completion	×	×	×	×	○	○	×	×	×
*3 SB01C8 (456)	Send/receive device number valid/invalid status	Indicates whether the send/receive device numbers (SW01C8 to SW01CF) of the remote master station or remote sub-master station are valid or invalid. Off: Invalid On: Valid	×	×	×	×	○	○	×	×	×

*3: Valid only when SB0047 is off. When it turns on (error), the last data are retained.

Table 2 Link special relay (SB) list (Continued)

No.	Name	Description	Availability							
			Control station		Normal station		Remote master station		Remote I/O station	
			Optical	Coaxial	Optical	Coaxial	Optical	Coaxial	Optical	Coaxial
*3 SB01E0 (480)	Network type consistency check	<p>Indicates whether there is a mismatch between the network types of the control station and normal stations on the network.</p> <ul style="list-style-type: none"> When the control station is in the MELSECNET/H Extended mode Off: All normal stations are set to the MELSECNET/H Extended mode. On: There is a normal station set to the MELSECNET/H mode or MELSECNET/10 mode. When the control station is in the MELSECNET/H mode or MELSECNET/10 mode Off: All normal stations are set to the MELSECNET/H mode or MELSECNET/10 mode. On: There is a normal station set to the MELSECNET/H Extended mode. <p>When a mismatch is found, the status of each station can be checked by Network type consistency check (SW01E0 to SW01E3). Depending on the timing of the link refresh, Network type consistency check (SW01E0 to SW01E3) and the update may be offset by one sequence scan.</p>	○	○	○	○	×	×	×	×
*3 SB01F4 (500)	Redundant system status (1)	<p>Indicates the operation mode of each station's CPU.</p> <p>Off: CPUs of all stations in backup mode On: Separate mode (excluding reserved stations and stations of the number exceeding the maximum)</p> <p>In the separate mode, the status of each station can be checked by Redundant system status (1) (SW01F4 to SW01F7). Depending on the timing of the link refresh, Redundant system status (1) (SW01F4 to SW01F7) and the update may be offset by one sequence scan.</p>	○	○	○	○	×	×	×	×
*3 SB01F8 (504)	Redundant system status (2)	<p>Indicates the pairing setting status of each station.</p> <p>Off: No pairing setting On: Pairing set station exists (excluding stations of the number exceeding the maximum)</p> <p>When a pairing set station exists, the status of each station can be checked by Redundant system status (2) (SW01F8 to SW01FB). Depending on the timing of the link refresh, Redundant system status (2) (SW01F8 to SW01FB) and the update may be offset by one sequence scan.</p>	○	○	○	○	×	×	×	×
*3 SB01FC (508)	Redundant system status (3)	<p>Indicates the operation status of each station's CPU (control system/standby system).</p> <p>Off: Control system CPUs on all stations On: Standby system CPU exists (excluding reserved stations and stations after the maximum station number)</p> <p>When a standby system CPU exists, the status of each station can be checked by Redundant system status (3) (SW01FC to SW01FF). Depending on the timing of the link refresh, Redundant system status (3) (SW01FC to SW01FF) and the update may be offset by one sequence scan.</p>	○	○	○	○	×	×	×	×

* 3: Valid only when SB0047 is off. When it turns on (error), the last data are retained.

Appendix 3 Link Special Register (SW)

In the link special register (SW), the data linking information is stored as numeric values. Thus, faulty areas and causes of errors can be checked using or monitoring the link special registers in the sequence programs.

Moreover, the link special register (SW) that stores the link status is used for the detailed information of the network diagnostics of GX Developer. For a list of the device numbers for each display item, refer to Section 8.1 "Network Diagnostics (Network Monitor)" and Section 8.3.1 "How to check error codes".

(1) When multiple network modules are mounted

Data in the link special register (SW) of each network module are refreshed to the following link special register (SW) areas of the CPU module when the refresh parameters of each network module are set to their default.

Module mounting position	Module 1	Module 2	Module 3	Module 4
Device number	SW0000 to 01FF	SW0200 to 03FF	SW0400 to 05FF	SW0600 to 07FF

(2) Range turned ON/OFF by user and range turned ON/OFF by system

The link special register (SW) has the user setting area range (SW0000 to SW001F) and the system setting area range (SW0020 to SW01FF). (The device numbers are the example when the network module is mounted in the position of Module 1.)

(3) List of link special register (SW) areas

The following lists the link special register (SW) areas (SW0000 to SW01FF).

POINT
(1) Do not turn ON the area which does not exist in the list. Doing so may cause malfunction of the programmable controller system.
(2) For how to use the link special register (SW), refer to Section 6.6.

Table 3 Link special register (SW) list

No.	Name	Description	Availability																																																													
			Control station		Normal station		Remote master station		Remote I/O station																																																							
			Optical	Coaxial	Optical	Coaxial	Optical	Coaxial	Optical	Coaxial																																																						
* 1 SW0000 (0)	Link stop/startup direction content	Sets the station that stops/restarts data linking. 00 _H : Host 01 _H : All stations 02 _H : Designated station 80 _H : Host (forced stop/restart) 81 _H : All stations (forced stop/restart) 82 _H : Designated station (forced stop/restart)	○	○	○	○	○	○	○	○																																																						
* 1 SW0001 (1) SW0002 (2) SW0003 (3) SW0004 (4)		Sets whether the designated station should execute data linking. (When the SW0000 is 02 _H or 82 _H .) Sets the bits to 1 for stations whose data linking is stopped/restarted. 0: Invalid data linking stop/restart instruction 1: Valid data linking stop/restart instruction	○	○	○	○	○	○	○	○																																																						
<table border="1" style="font-size: small;"> <tr> <td>b15</td><td>b14</td><td>b13</td><td>b12</td><td>to</td><td>b4</td><td>b3</td><td>b2</td><td>b1</td><td>b0</td> </tr> <tr> <td>SW0001</td><td>16</td><td>15</td><td>14</td><td>13</td><td>to</td><td>5</td><td>4</td><td>3</td><td>2</td><td>1</td> </tr> <tr> <td>SW0002</td><td>32</td><td>31</td><td>30</td><td>29</td><td>to</td><td>21</td><td>20</td><td>19</td><td>18</td><td>17</td> </tr> <tr> <td>SW0003</td><td>48</td><td>47</td><td>46</td><td>45</td><td>to</td><td>37</td><td>36</td><td>35</td><td>34</td><td>33</td> </tr> <tr> <td>SW0004</td><td>64</td><td>63</td><td>62</td><td>61</td><td>to</td><td>53</td><td>52</td><td>51</td><td>50</td><td>49</td> </tr> </table>		b15	b14	b13	b12	to	b4	b3	b2	b1	b0	SW0001	16	15	14	13	to	5	4	3	2	1	SW0002	32	31	30	29	to	21	20	19	18	17	SW0003	48	47	46	45	to	37	36	35	34	33	SW0004	64	63	62	61	to	53	52	51	50	49	The numbers 1 to 64 in the above table indicate the station numbers.								
b15		b14	b13	b12	to	b4	b3	b2	b1	b0																																																						
SW0001		16	15	14	13	to	5	4	3	2	1																																																					
SW0002	32	31	30	29	to	21	20	19	18	17																																																						
SW0003	48	47	46	45	to	37	36	35	34	33																																																						
SW0004	64	63	62	61	to	53	52	51	50	49																																																						
SW0008 (8)	Logical channel setting (channel 1)	Sets the logical channel number for physical channel number 1. (Valid only for channels on the receiving side) 0 : Logical channel number 1 (default) 1 to 64 : Other logical channel number is set.	○	○	○	○	×	×	×	×																																																						
SW0009 (9)	Logical channel setting (channel 2)	Sets the logical channel number for physical channel number 2. (Valid only for channels on the receiving side) 0 : Logical channel number 2 (default) 1 to 64 : Other logical channel number is set.	○	○	○	○	×	×	×	×																																																						
SW000A (10)	Logical channel setting (channel 3)	Sets the logical channel number for physical channel number 3. (Valid only for channels on the receiving side) 0 : Logical channel number 3 (default) 1 to 64 : Other logical channel number is set.	○	○	○	○	×	×	×	×																																																						

[Availability column] Optical: optical loop, Coaxial: coaxial bus
○: Available, ×: Not available

* 1: Used in the network test of GX Developer.

Table 3 Link special register (SW) list (Continued)

No.	Name	Description	Availability							
			Control station		Normal station		Remote master station		Remote I/O station	
			Optical	Coaxial	Optical	Coaxial	Optical	Coaxial	Optical	Coaxial
SW000B (11)	Logical channel setting (channel 4)	Sets the logical channel number for physical channel number 4. (Valid only for channels on the receiving side) 0 : Logical channel number 4 (default) 1 to 64 : Other logical channel number is set.	○	○	○	○	×	×	×	×
SW000C (12)	Logical channel setting (channel 5)	Sets the logical channel number for physical channel number 5. (Valid only for channels on the receiving side) 0 : Logical channel number 5 (default) 1 to 64 : Other logical channel number is set.	○	○	○	○	×	×	×	×
SW000D (13)	Logical channel setting (channel 6)	Sets the logical channel number for physical channel number 6. (Valid only for channels on the receiving side) 0 : Logical channel number 6 (default) 1 to 64 : Other logical channel number is set.	○	○	○	○	×	×	×	×
SW000E (14)	Logical channel setting (channel 7)	Sets the logical channel number for physical channel number 7. (Valid only for channels on the receiving side) 0 : Logical channel number 7 (default) 1 to 64 : Other logical channel number is set.	○	○	○	○	×	×	×	×
SW000F (15)	Logical channel setting (channel 8)	Sets the logical channel number for physical channel number 8. (Valid only for channels on the receiving side) 0 : Logical channel number 8 (default) 1 to 64 : Other logical channel number is set.	○	○	○	○	×	×	×	×
SW0018 (24)	System switching monitoring time setting	Set the time from the occurrence of a data link error to the recognition of data link stop in the redundant system. 0 : 2 s (default) 1 to 500 : Units of 10 ms (Units of 10 ms for 10 ms to 5 s)	○	○	○	○	○	○	×	×
*2 SW001C (28)	Number of retries	Indicates the change of the number of retries for the time of the issue of a request in send and receive instructions. 0 : 7 times (default) 1 to 7 : Setting exists	○	○	○	○	○	○	×	×
*2 SW001D (29)	Retry interval	Indicates the change of the retry interval for the time of the issue of a request in send and receive instructions. 0 : 100 ms (default) 1 to FE _H : Setting exists (unit: ms)	○	○	○	○	○	○	×	×
*2 SW001E (30)	Number of gates	Indicates the change of the number of gates for the time of the issue of a request in send and receive instructions. 0 : 7 (default) 1 to EF _H : Setting exists	○	○	○	○	○	○	×	×
SW0020 (32)	Module status	Stores the status of the network module. Stores the communication status between the network module and the CPU module. 0 : Normal Other than 0 : The error code is stored. (Refer to the manual for the CPU module used.)	○	○	○	○	○	○	×	×
SW0031 (49)	ZNRD instruction processing result	Indicates the processing result of the ZNRD instruction. 0 : Normal completion Other than 0 : Abnormal completion (refer to the error codes in Section 8.3)	○	○	○	○	×	×	×	×
	Send/receive instruction (1) processing result	Indicates the processing results of the SEND/RCV/READ/ WRITE/REQ/RECVS/RRUN/RSTOP/RTMRD/RTMWR/REMFRL/ REMTO instructions (when physical channel 1 is used). 0 : Normal completion Other than 0 : Abnormal completion (see the error codes in Section 8.3)	○	○	○	○	○	○	×	×

*2: Valid only when SB0047 is off. When it turns on (error), the last data are retained.

Table 3 Link special register (SW) list (Continued)

No.	Name	Description	Availability							
			Control station		Normal station		Remote master station		Remote I/O station	
			Optical	Coaxial	Optical	Coaxial	Optical	Coaxial	Optical	Coaxial
SW0033 (51)	ZNWR instruction processing result	Indicates the processing result of the ZNWR instruction. 0 : Normal completion Other than 0 : Abnormal completion (refer to the error codes in Section 8.3)	○	○	○	○	×	×	×	×
	Send/receive instruction (2) processing result	Indicates the processing results of the SEND/RECV/READ/WRITE/REQ/RECVS/RRUN/RSTOP/RTMRD/RTMWR/REMFR/REMTO instructions (when physical channel 2 is used). 0 : Normal completion Other than 0 : Abnormal completion (refer to the error codes in Section 8.3)	○	○	○	○	○	○	×	×
SW0035 (53)	Send/receive instruction (3) processing result	Indicates the processing results of the SEND/RECV/READ/WRITE/REQ/RECVS/RRUN/RSTOP/RTMRD/RTMWR/REMFR/REMTO instructions (when physical channel 3 is used). 0 : Normal completion Other than 0 : Abnormal completion (refer to the error codes in Section 8.3)	○	○	○	○	○	○	×	×
SW0037 (55)	Send/receive instruction (4) processing result	Indicates the processing results of the SEND/RECV/READ/WRITE/REQ/RECVS/RRUN/RSTOP/RTMRD/RTMWR/REMFR/REMTO instructions (when physical channel 4 is used). 0 : Normal completion Other than 0 : Abnormal completion (refer to the error codes in Section 8.3)	○	○	○	○	○	○	×	×
SW0039 (57)	Send/receive instruction (5) processing result	Indicates the processing results of the SEND/RECV/READ/WRITE/REQ/RECVS/RRUN/RSTOP/RTMRD/RTMWR/REMFR/REMTO instructions (when physical channel 5 is used). 0 : Normal completion Other than 0 : Abnormal completion (refer to the error codes in Section 8.3)	○	○	○	○	○	○	×	×
SW003B (59)	Send/receive instruction (6) processing result	Indicates the processing results of the SEND/RECV/READ/WRITE/REQ/RECVS/RRUN/RSTOP/RTMRD/RTMWR/REMFR/REMTO instructions (when physical channel 6 is used). 0 : Normal completion Other than 0 : Abnormal completion (refer to the error codes in Section 8.3)	○	○	○	○	○	○	×	×
SW003D (61)	Send/receive instruction (7) processing result	Indicates the processing results of the SEND/RECV/READ/WRITE/REQ/RECVS/RRUN/RSTOP/RTMRD/RTMWR/REMFR/REMTO instructions (when physical channel 7 is used). 0 : Normal completion Other than 0 : Abnormal completion (refer to the error codes in Section 8.3)	○	○	○	○	○	○	×	×
SW003F (63)	Send/receive instruction (8) processing result	Indicates the processing results of the SEND/RECV/READ/WRITE/REQ/RECVS/RRUN/RSTOP/RTMRD/RTMWR/REMFR/REMTO instructions (when physical channel 8 is used). 0 : Normal completion Other than 0 : Abnormal completion (refer to the error codes in Section 8.3)	○	○	○	○	○	○	×	×
SW0040 (64)	Network No.	Stores the network number of the host. Range: 1 to 239	○	○	○	○	○	○	○	○
SW0041 (65)	Group No.	Stores the group number of the host. 0 : No group designation 1 to 32 : Group No.	○	○	○	○	○	○	×	×
SW0042 (66)	Station No.	Stores the station No. of host station. 1 to 64 : Station No. 7D _H : Remote master station	○	○	○	○	○	○	○	○
SW0043 (67)	Mode status	Stores the mode status of the host. 0 : Online 2 : Offline 3 or more : Applicable test	○	○	○	○	○	○	○	○

Table 3 Link special register (SW) list (Continued)

No.	Name	Description	Availability							
			Control station		Normal station		Remote master station		Remote I/O station	
			Optical	Coaxial	Optical	Coaxial	Optical	Coaxial	Optical	Coaxial
SW0044 (68)	Station setting	On PLC to PLC network: Stores the condition setting switch status of the host. 0: Off 1: On <p>Network type (0: PLC to PLC network) Station type (0: Normal station, 1: Control station) Control station operation (0: Switch to designated control station, 1: Keep current control station) Operation mode (0: Online mode, 1: Debug mode) Host station network type (0: MELSECNET/H mode, MELSECNET/10 mode, 1: MELSECNET/H Extended mode)</p>	○	○	○	○	×	×	×	×
		On remote I/O network: Stores the condition setting switch status of the host. 0: Off 1: On <p>Network type (1: Remote I/O network) Station type (0: Multiplexed remote sub-master station, remote I/O station, 1: Multiplexed remote master station) Return mode (0: Master station returns as master operating station (control station), 1: Master station returns as sub-master operating station (standby station).) Parameter status (0: Without parameters for remote sub-master station, 1: With parameters for master station and sub-master station)</p>	×	×	×	×	○	○	○	○
SW0046 (70)	Module type	Stores the network module type of the host. <p>01: Optical 10: Coaxial 11: Twisted 0: Duplex 1: Single 0: Loop 1: Bus</p>	○	○	○	○	○	○	○	○
SW0047 (71)	Baton pass status (host)	Stores the baton pass status of the host. 00H: Executing data linking 01H: Data linking stopped (instructed by other station) 02H: Data linking stopped (instructed by host) 03H: Executing baton pass (parameter received (no transmission area in the host)) 04H: Executing baton pass (parameter error) 05H: Executing baton pass (parameter not received) 06H: Being disconnected (no baton pass) 07H: Being disconnected (line error) 11H: Loop test 12H: Setup confirmation test 13H: Station order check test 14H: Communication test 1FH: Offline test	○	○	○	○	○	○	○	○
SW0048 (72)	Cause of baton pass interruption	Stores the cause of baton pass interruption of the host. 0 : Normal communication 1 : Offline 2 : Offline test 3 or more : Cause of interruption (refer to the error codes in Section 8.3)	○	○	○	○	○	○	○	○
SW0049 (73)	Cause of data link stop	Stores the cause of data linking stop of the host. 0: Normal 1: Stop instructed 2: No common parameters 3: Common parameter error 4: Host CPU error 6: Communication aborted	○	○	○	○	○	○	○	○

Table 3 Link special register (SW) list (Continued)

No.	Name	Description	Availability																													
			Control station		Normal station		Remote master station		Remote I/O station																							
			Optical	Coaxial	Optical	Coaxial	Optical	Coaxial	Optical	Coaxial																						
*2 SW004A (74)	Data linking stop request station	Stores the station that stopped the host data linking. (Valid when the SW0049 is 1.) SW004A <table border="1" style="display: inline-table; vertical-align: middle;"> <tr> <td>b15</td><td>b14</td><td>to</td><td>b7</td><td>b6</td><td>b5</td><td>b4</td><td>b3</td><td>b2</td><td>b1</td><td>b0</td> </tr> <tr> <td>0</td><td></td><td>to</td><td>0</td><td></td><td></td><td></td><td></td><td></td><td></td><td></td> </tr> </table> 0: Host 1 to 64: Station number 0: Station number designated 1: All stations designated b0 to b6 store 7D _H if a data link stop request is received from the remote master station/multiplexed remote master station.	b15	b14	to	b7	b6	b5	b4	b3	b2	b1	b0	0		to	0								○	○	○	○	○	○	○	○
b15	b14	to	b7	b6	b5	b4	b3	b2	b1	b0																						
0		to	0																													
*2 SW004B (75)	Host CPU status	Indicates the CPU status of the host. 0 : Normal Other than 0 : Abnormal (For the error codes, refer to Section 8.3 or the "Error Code" chapter of QCPU User's Manual (Hardware Design, Maintenance and Inspection).)	○	○	○	○	○	○	×	×																						
*2 SW004D (77)	Data linking start status (host)	Stores the result of starting cyclic transmission with Link startup (host) (SB0000). 0 : Normal Other than 0 : Abnormal (refer to the error codes in Section 8.3)	○	○	○	○	○	○	○	○																						
*2 SW004F (79)	Data linking stop status (host)	Stores the result of stopping cyclic transmission with Link stop (host) (SB0001). 0 : Normal Other than 0 : Abnormal (refer to the error codes in Section 8.3)	○	○	○	○	○	○	○	○																						
*2 SW0051 (81)	Data linking start status (entire system)	Stores the result of starting cyclic transmission with System link startup (SB0002). 0 : Normal Other than 0 : Abnormal (refer to the error codes in Section 8.3)	○	○	○	○	○	○	○	○																						
*2 SW0053 (83)	Data linking stop status (entire system)	Stores the result of stopping cyclic transmission with System link stop (SB0003). 0 : Normal Other than 0 : Abnormal (refer to the error codes in Section 8.3)	○	○	○	○	○	○	○	○																						
*2 SW0054 (84)	Parameter information	At the PLC to PLC network. Stores the parameter information. (When the SB0054 and SB0055 are off.) b15 b14 to b2 b1 b0 <table border="1" style="display: inline-table; vertical-align: middle;"> <tr> <td>0</td><td></td><td>to</td><td>0</td><td></td><td></td><td></td> </tr> </table> MELSECNET/H Type 0: Not designated 00: Use only common parameters 1: Designated 01: Common parameters + station specific parameters 10: Use only default parameters 11: Default parameters + station specific parameters	0		to	0				○	○	○	○	×	×	×	×															
		0		to	0																											
(When the SB0055 is on.) b15 b4 b3 b2 b1 b0 <table border="1" style="display: inline-table; vertical-align: middle;"> <tr> <td>0</td><td></td><td>to</td><td>0</td><td>0</td><td>1</td><td>1</td><td>1</td><td>1</td> </tr> </table> = 0F _H : Parameter error Check the error code in the SW0055. When remote I/O net Stores the parameter information. (When the SB0054 and SB0055 are off.) b15 to b3 b2 b1 b0 <table border="1" style="display: inline-table; vertical-align: middle;"> <tr> <td>0</td><td></td><td>to</td><td>0</td><td></td><td>0</td><td>0</td> </tr> </table> Intelligent function module parameter 0: No 1: Yes	0		to	0	0	1	1	1	1	0		to	0		0	0	×	×	×	×	×	×	○	○								
0		to	0	0	1	1	1	1																								
0		to	0		0	0																										





*2: Valid only when SB0047 is off. When it turns on (error), the last data are retained.

Table 3 Link special register (SW) list (Continued)

No.	Name	Description	Availability																																																														
			Control station		Normal station		Remote master station		Remote I/O station																																																								
			Optical	Coaxial	Optical	Coaxial	Optical	Coaxial	Optical	Coaxial																																																							
SW0055 (85)	Parameter setting status	At the PLC to PLC network. Stores the status of the parameters. 0 : Normal parameter 1 or more : Abnormal parameter (refer to the error codes in Section 8.3)	○	○	○	○	○	○	○	○	○	○																																																					
*2 SW0056 (86)	Current control station	At the PLC to PLC network. Stores the number of the station that actually operates as the control station (including a sub-control station). Range: 1 to 64	○	○	○	○	×	×	×	×	×	×																																																					
	Current remote master station	When remote I/O network Stores the station number controlling the current baton pass. 7DH : Remote master station or multiplexed remote master station 1 to 64 : Multiplexed remote sub-master station	×	×	×	×	○	○	○	○	○	○																																																					
SW0057 (87)	Designated control station	At the PLC to PLC network. Stores the number of the station that is set as the control station. Range: 1 to 64 0: Designated control station error	○	○	○	○	×	×	×	×	×	×																																																					
	Designated remote master station	When remote I/O network. 7DH : Remote master station Other than 7DH : Remote master station error.	×	×	×	×	○	○	○	○	○	○																																																					
SW0059 (89)	Total number of link stations	Stores the total number of link stations that is set with the parameters. Range: 1 to 64 (64 when there is no parameter.)	○	○	○	○	○	○	○	○	○	○																																																					
*2 SW005A (90)	Maximum baton pass station	Stores the maximum station number among the stations executing the baton pass. Range: 1 to 64	○	○	○	○	○	○	○	○	○	○																																																					
*2 SW005B (91)	Maximum cyclic transmission station	Stores the maximum station number among the stations executing the cyclic transmission. Range: 1 to 64	○	○	○	○	○	○	○	○	○	○																																																					
SW005C (92)	I/O master station (block 1)	Stores the station number of the I/O master station of block 1 with PLC to PLC network. 0 : None 1 to 64 : Station number Valid when the SB0049 is off.	○	○	○	○	×	×	×	×	×	×																																																					
SW005D (93)	I/O master station (block 2)	Stores the station number of the I/O master station of block 2 with PLC to PLC network. 0 : None 1 to 64 : Station number Valid when the SB0049 is off.	○	○	○	○	×	×	×	×	×	×																																																					
SW0064 (100)/ SW0065 (101)/ SW0066 (102)/ SW0067 (103)	Reserved station designation	Stores the stations that are set as reserved stations. 0: Other than reserved station 1: Reserved station Valid when the SB0049 is off. <table border="1" style="margin-left: 20px;"> <tr> <td>b15</td><td>b14</td><td>b13</td><td>b12</td><td>to</td><td>b4</td><td>b3</td><td>b2</td><td>b1</td><td>b0</td> </tr> <tr> <td>SW0064</td><td>16</td><td>15</td><td>14</td><td>13</td><td>to</td><td>5</td><td>4</td><td>3</td><td>2</td><td>1</td> </tr> <tr> <td>SW0065</td><td>32</td><td>31</td><td>30</td><td>29</td><td>to</td><td>21</td><td>20</td><td>19</td><td>18</td><td>17</td> </tr> <tr> <td>SW0066</td><td>48</td><td>47</td><td>46</td><td>45</td><td>to</td><td>37</td><td>36</td><td>35</td><td>34</td><td>33</td> </tr> <tr> <td>SW0067</td><td>64</td><td>63</td><td>62</td><td>61</td><td>to</td><td>53</td><td>52</td><td>51</td><td>50</td><td>49</td> </tr> </table> Numbers 1 to 64 in the above table indicate the station numbers.	b15	b14	b13	b12	to	b4	b3	b2	b1	b0	SW0064	16	15	14	13	to	5	4	3	2	1	SW0065	32	31	30	29	to	21	20	19	18	17	SW0066	48	47	46	45	to	37	36	35	34	33	SW0067	64	63	62	61	to	53	52	51	50	49	○	○	○	○	○	○	○	○	○
b15	b14	b13	b12	to	b4	b3	b2	b1	b0																																																								
SW0064	16	15	14	13	to	5	4	3	2	1																																																							
SW0065	32	31	30	29	to	21	20	19	18	17																																																							
SW0066	48	47	46	45	to	37	36	35	34	33																																																							
SW0067	64	63	62	61	to	53	52	51	50	49																																																							
SW0068 (104)	Communication mode	Stores the status of the constant link scan settings. 0 : No storage 1 to 500 : Setting time (ms) Valid when the SB0049 is off.	○	○	○	○	○	○	○	○	○	○																																																					

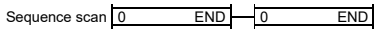
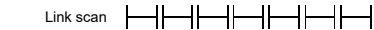
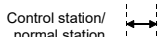
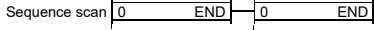
*2: Valid only when SB0047 is off. When it turns on (error), the last data are retained.

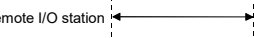
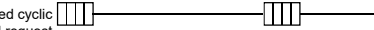
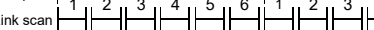
Table 3 Link special register (SW) list (Continued)

No.	Name	Description	Availability																																																																	
			Control station		Normal station		Remote master station		Remote I/O station																																																											
			Optical	Coaxial	Optical	Coaxial	Optical	Coaxial	Optical	Coaxial																																																										
*2 SW006B (107)	Maximum link scan time	Stores the maximum/minimum/current values of the link scan time (unit (ms)). The values for the control station and normal stations vary.	○	○	○	○	○	○	○	○	○	○	○																																																							
*2 SW006C (108)	Minimum link scan time	(PLC to PLC network) Sequence scan  Link scan  Control station/normal station 	○	○	○	○	○	○	○	○	○	○	○																																																							
*2 SW006D (109)	Current link scan time	When the constant scan is set, the values are as follows: Control station (Setting value) < Measured link scan value + KB of the link scan time equation → Measured link scan value + KB of the link scan time equation (Setting value) > Measured link scan value + KB of the link scan time equation → Measured link scan value Normal station → Constant link scan that has been set. (Remote I/O network) Sequence scan  Link scan  Remote master station  Remote I/O station 	○	○	○	○	○	○	○	○	○	○	○																																																							
*2 SW006E (110)	Low-speed cyclic scan time	Stores the number of link scans in the send interval of the low-speed cyclic transmission. Low-speed cyclic send request  Link scan  Low-speed cyclic transmission  Send interval	○	○	○	○	×	×	×	×	×	×	×																																																							
*2 SW0070 (112)/ SW0071 (113)/ SW0072 (114)/ SW0073 (115)	Baton pass status of each station	Stores the baton pass status of each station (including the host). <Online> 0: Normal (including the stations with the maximum station number and smaller numbers as well as reserved stations) 1: Abnormal <Offline test> 0: Normal 1: Abnormal (including the stations with the maximum station number and smaller numbers as well as reserved stations) <table border="1" data-bbox="544 1464 986 1621"> <tr> <td></td> <td>b15</td> <td>b14</td> <td>b13</td> <td>b12</td> <td>to</td> <td>b4</td> <td>b3</td> <td>b2</td> <td>b1</td> <td>b0</td> </tr> <tr> <td>SW0070</td> <td>16</td> <td>15</td> <td>14</td> <td>13</td> <td>to</td> <td>5</td> <td>4</td> <td>3</td> <td>2</td> <td>1</td> </tr> <tr> <td>SW0071</td> <td>32</td> <td>31</td> <td>30</td> <td>29</td> <td>to</td> <td>21</td> <td>20</td> <td>19</td> <td>18</td> <td>17</td> </tr> <tr> <td>SW0072</td> <td>48</td> <td>47</td> <td>46</td> <td>45</td> <td>to</td> <td>37</td> <td>36</td> <td>35</td> <td>34</td> <td>33</td> </tr> <tr> <td>SW0073</td> <td>64</td> <td>63</td> <td>62</td> <td>61</td> <td>to</td> <td>53</td> <td>52</td> <td>51</td> <td>50</td> <td>49</td> </tr> </table> <small>Numbers 1 to 64 in the above table indicate the station numbers.</small>		b15	b14	b13	b12	to	b4	b3	b2	b1	b0	SW0070	16	15	14	13	to	5	4	3	2	1	SW0071	32	31	30	29	to	21	20	19	18	17	SW0072	48	47	46	45	to	37	36	35	34	33	SW0073	64	63	62	61	to	53	52	51	50	49	○	○	○	○	○	○	○	○	○	○	○
	b15	b14	b13	b12	to	b4	b3	b2	b1	b0																																																										
SW0070	16	15	14	13	to	5	4	3	2	1																																																										
SW0071	32	31	30	29	to	21	20	19	18	17																																																										
SW0072	48	47	46	45	to	37	36	35	34	33																																																										
SW0073	64	63	62	61	to	53	52	51	50	49																																																										

*2: Valid only when SB0047 is off. When it turns on (error), the last data are retained.

Table 3 Link special register (SW) list (Continued)

No.	Name	Description	Availability																																																									
			Control station		Normal station		Remote master station		Remote I/O station																																																			
			Optical	Coaxial	Optical	Coaxial	Optical	Coaxial	Optical	Coaxial																																																		
*2 SW0074 (116)/ SW0075 (117)/ W0076 (118)/ SW0077 (119)	Cyclic transmission status of each station	Stores the cyclic transmission status of each station (including the host). 0: Executing cyclic transmission (including the station with the maximum station number and smaller number as well as reserved stations) 1: Cyclic transmission not executed <table border="1"> <thead> <tr> <th>b15</th> <th>b14</th> <th>b13</th> <th>b12</th> <th>to</th> <th>b4</th> <th>b3</th> <th>b2</th> <th>b1</th> <th>b0</th> </tr> </thead> <tbody> <tr> <td>16</td> <td>15</td> <td>14</td> <td>13</td> <td>to</td> <td>5</td> <td>4</td> <td>3</td> <td>2</td> <td>1</td> </tr> <tr> <td>32</td> <td>31</td> <td>30</td> <td>29</td> <td>to</td> <td>21</td> <td>20</td> <td>19</td> <td>18</td> <td>17</td> </tr> <tr> <td>48</td> <td>47</td> <td>46</td> <td>45</td> <td>to</td> <td>37</td> <td>36</td> <td>35</td> <td>34</td> <td>33</td> </tr> <tr> <td>64</td> <td>63</td> <td>62</td> <td>61</td> <td>to</td> <td>53</td> <td>52</td> <td>51</td> <td>50</td> <td>49</td> </tr> </tbody> </table> <small>Numbers 1 to 64 in the above table indicate the station numbers.</small> If a CPU module installed together with QJ71LP21S-25 is turned OFF, detection of a data link error may take more time than usual. For immediate detection of a data link error, program an interlock using the link relay (LB) in each station's send range. For details, refer to the Q Corresponding MELSECNET/H Network System Reference Manual (PLC to PLC network).	b15	b14	b13	b12	to	b4	b3	b2	b1	b0	16	15	14	13	to	5	4	3	2	1	32	31	30	29	to	21	20	19	18	17	48	47	46	45	to	37	36	35	34	33	64	63	62	61	to	53	52	51	50	49	○	○	○	○	○	○	○	○
b15	b14	b13	b12	to	b4	b3	b2	b1	b0																																																			
16	15	14	13	to	5	4	3	2	1																																																			
32	31	30	29	to	21	20	19	18	17																																																			
48	47	46	45	to	37	36	35	34	33																																																			
64	63	62	61	to	53	52	51	50	49																																																			
*2 SW0078 (120)/ SW0079 (121)/ SW007A (122)/ SW007B (123)	Parameter communication status of each station	Stores the parameter communication status of each station. 0: Executing communication other than parameter communication (including the stations with the maximum station number and smaller numbers as well as reserved stations) 1: Executing parameter communication <table border="1"> <thead> <tr> <th>b15</th> <th>b14</th> <th>b13</th> <th>b12</th> <th>to</th> <th>b4</th> <th>b3</th> <th>b2</th> <th>b1</th> <th>b0</th> </tr> </thead> <tbody> <tr> <td>16</td> <td>15</td> <td>14</td> <td>13</td> <td>to</td> <td>5</td> <td>4</td> <td>3</td> <td>2</td> <td>1</td> </tr> <tr> <td>32</td> <td>31</td> <td>30</td> <td>29</td> <td>to</td> <td>21</td> <td>20</td> <td>19</td> <td>18</td> <td>17</td> </tr> <tr> <td>48</td> <td>47</td> <td>46</td> <td>45</td> <td>to</td> <td>37</td> <td>36</td> <td>35</td> <td>34</td> <td>33</td> </tr> <tr> <td>64</td> <td>63</td> <td>62</td> <td>61</td> <td>to</td> <td>53</td> <td>52</td> <td>51</td> <td>50</td> <td>49</td> </tr> </tbody> </table> <small>Numbers 1 to 64 in the above table indicate the station numbers.</small>	b15	b14	b13	b12	to	b4	b3	b2	b1	b0	16	15	14	13	to	5	4	3	2	1	32	31	30	29	to	21	20	19	18	17	48	47	46	45	to	37	36	35	34	33	64	63	62	61	to	53	52	51	50	49	○	○	×	×	○	○	×	×
b15	b14	b13	b12	to	b4	b3	b2	b1	b0																																																			
16	15	14	13	to	5	4	3	2	1																																																			
32	31	30	29	to	21	20	19	18	17																																																			
48	47	46	45	to	37	36	35	34	33																																																			
64	63	62	61	to	53	52	51	50	49																																																			
*2 SW007C (124)/ SW007D (125)/ SW007E (126)/ SW007F (127)	Parameter error status of each station	Stores the parameter status of each station 0: Normal parameter (including the maximum station number and smaller numbers as well as reserved stations) 1: Abnormal parameter <table border="1"> <thead> <tr> <th>b15</th> <th>b14</th> <th>b13</th> <th>b12</th> <th>to</th> <th>b4</th> <th>b3</th> <th>b2</th> <th>b1</th> <th>b0</th> </tr> </thead> <tbody> <tr> <td>16</td> <td>15</td> <td>14</td> <td>13</td> <td>to</td> <td>5</td> <td>4</td> <td>3</td> <td>2</td> <td>1</td> </tr> <tr> <td>32</td> <td>31</td> <td>30</td> <td>29</td> <td>to</td> <td>21</td> <td>20</td> <td>19</td> <td>18</td> <td>17</td> </tr> <tr> <td>48</td> <td>47</td> <td>46</td> <td>45</td> <td>to</td> <td>37</td> <td>36</td> <td>35</td> <td>34</td> <td>33</td> </tr> <tr> <td>64</td> <td>63</td> <td>62</td> <td>61</td> <td>to</td> <td>53</td> <td>52</td> <td>51</td> <td>50</td> <td>49</td> </tr> </tbody> </table> <small>Numbers 1 to 64 in the above table indicate the station numbers.</small>	b15	b14	b13	b12	to	b4	b3	b2	b1	b0	16	15	14	13	to	5	4	3	2	1	32	31	30	29	to	21	20	19	18	17	48	47	46	45	to	37	36	35	34	33	64	63	62	61	to	53	52	51	50	49	○	○	×	×	○	○	×	×
b15	b14	b13	b12	to	b4	b3	b2	b1	b0																																																			
16	15	14	13	to	5	4	3	2	1																																																			
32	31	30	29	to	21	20	19	18	17																																																			
48	47	46	45	to	37	36	35	34	33																																																			
64	63	62	61	to	53	52	51	50	49																																																			
*2 *11 SW0080 (128)/ SW0081 (129)/ SW0082 (130)/ SW0083 (131)	CPU operation status of each station (1)	Stores each station's CPU status (including the host). Valid only for stations registered as normal in the SW0070 to SW0073. 0: Normal (including the stations with the maximum station number and smaller numbers as well as reserved stations) 1: Serious/fatal error <table border="1"> <thead> <tr> <th>b15</th> <th>b14</th> <th>b13</th> <th>b12</th> <th>to</th> <th>b4</th> <th>b3</th> <th>b2</th> <th>b1</th> <th>b0</th> </tr> </thead> <tbody> <tr> <td>16</td> <td>15</td> <td>14</td> <td>13</td> <td>to</td> <td>5</td> <td>4</td> <td>3</td> <td>2</td> <td>1</td> </tr> <tr> <td>32</td> <td>31</td> <td>30</td> <td>29</td> <td>to</td> <td>21</td> <td>20</td> <td>19</td> <td>18</td> <td>17</td> </tr> <tr> <td>48</td> <td>47</td> <td>46</td> <td>45</td> <td>to</td> <td>37</td> <td>36</td> <td>35</td> <td>34</td> <td>33</td> </tr> <tr> <td>64</td> <td>63</td> <td>62</td> <td>61</td> <td>to</td> <td>53</td> <td>52</td> <td>51</td> <td>50</td> <td>49</td> </tr> </tbody> </table> <small>Numbers 1 to 64 in the above table indicate the station numbers.</small>	b15	b14	b13	b12	to	b4	b3	b2	b1	b0	16	15	14	13	to	5	4	3	2	1	32	31	30	29	to	21	20	19	18	17	48	47	46	45	to	37	36	35	34	33	64	63	62	61	to	53	52	51	50	49	○	○	○	○	○	○	×	×
b15	b14	b13	b12	to	b4	b3	b2	b1	b0																																																			
16	15	14	13	to	5	4	3	2	1																																																			
32	31	30	29	to	21	20	19	18	17																																																			
48	47	46	45	to	37	36	35	34	33																																																			
64	63	62	61	to	53	52	51	50	49																																																			

* 2: Valid only when SB0047 is off. When it turns on (error), the last data are retained.

* 11: Serious errors are the type of errors that stop the CPU operation.

Fatal errors are also the type of errors that stop the CPU operation. (Refer to Section 8.3.3.)

Table 3 Link special register (SW) list (Continued)

No.	Name	Description	Availability																																																														
			Control station		Normal station		Remote master station		Remote I/O station																																																								
			Optical	Coaxial	Optical	Coaxial	Optical	Coaxial	Optical	Coaxial																																																							
* 2 SW0084 (132)/ SW0085 (133)/ SW0086 (134)/ SW0087 (135)	CPU RUN status of each station	Stores the CPU RUN status of each station (including the host). The standby-system Q4ARCPU stores the key switch status at normal state. Valid only for stations registered as normal in the SW0070 to SW0073. 0: RUN or STEP RUN (including the stations with the maximum station number and smaller numbers as well as reserved stations) 1: STOP, PAUSE, ERROR <table border="1"> <thead> <tr> <th></th> <th>b15</th> <th>b14</th> <th>b13</th> <th>b12</th> <th>to</th> <th>b4</th> <th>b3</th> <th>b2</th> <th>b1</th> <th>b0</th> </tr> </thead> <tbody> <tr> <td>SW0084</td> <td>16</td> <td>15</td> <td>14</td> <td>13</td> <td>to</td> <td>5</td> <td>4</td> <td>3</td> <td>2</td> <td>1</td> </tr> <tr> <td>SW0085</td> <td>32</td> <td>31</td> <td>30</td> <td>29</td> <td>to</td> <td>21</td> <td>20</td> <td>19</td> <td>18</td> <td>17</td> </tr> <tr> <td>SW0086</td> <td>48</td> <td>47</td> <td>46</td> <td>45</td> <td>to</td> <td>37</td> <td>36</td> <td>35</td> <td>34</td> <td>33</td> </tr> <tr> <td>SW0087</td> <td>64</td> <td>63</td> <td>62</td> <td>61</td> <td>to</td> <td>53</td> <td>52</td> <td>51</td> <td>50</td> <td>49</td> </tr> </tbody> </table> <small>Numbers 1 to 64 in the above table indicate the station numbers.</small>		b15	b14	b13	b12	to	b4	b3	b2	b1	b0	SW0084	16	15	14	13	to	5	4	3	2	1	SW0085	32	31	30	29	to	21	20	19	18	17	SW0086	48	47	46	45	to	37	36	35	34	33	SW0087	64	63	62	61	to	53	52	51	50	49	○	○	○	○	○	○	×	×
	b15	b14	b13	b12	to	b4	b3	b2	b1	b0																																																							
SW0084	16	15	14	13	to	5	4	3	2	1																																																							
SW0085	32	31	30	29	to	21	20	19	18	17																																																							
SW0086	48	47	46	45	to	37	36	35	34	33																																																							
SW0087	64	63	62	61	to	53	52	51	50	49																																																							
* 2 * 10 SW0088 (136)/ SW0089 (137)/ SW008A (138)/ SW008B (139)	CPU operation status of each station (2)	Stores each station's CPU status (including the host). Valid only for stations registered as normal in the SW0070 to SW0073. 0: Normal (including the stations with the maximum station number and smaller numbers as well as reserved stations) 1: Minor error <table border="1"> <thead> <tr> <th></th> <th>b15</th> <th>b14</th> <th>b13</th> <th>b12</th> <th>to</th> <th>b4</th> <th>b3</th> <th>b2</th> <th>b1</th> <th>b0</th> </tr> </thead> <tbody> <tr> <td>SW0088</td> <td>16</td> <td>15</td> <td>14</td> <td>13</td> <td>to</td> <td>5</td> <td>4</td> <td>3</td> <td>2</td> <td>1</td> </tr> <tr> <td>SW0089</td> <td>32</td> <td>31</td> <td>30</td> <td>29</td> <td>to</td> <td>21</td> <td>20</td> <td>19</td> <td>18</td> <td>17</td> </tr> <tr> <td>SW008A</td> <td>48</td> <td>47</td> <td>46</td> <td>45</td> <td>to</td> <td>37</td> <td>36</td> <td>35</td> <td>34</td> <td>33</td> </tr> <tr> <td>SW008B</td> <td>64</td> <td>63</td> <td>62</td> <td>61</td> <td>to</td> <td>53</td> <td>52</td> <td>51</td> <td>50</td> <td>49</td> </tr> </tbody> </table> <small>Numbers 1 to 64 in the above table indicate the station numbers.</small>		b15	b14	b13	b12	to	b4	b3	b2	b1	b0	SW0088	16	15	14	13	to	5	4	3	2	1	SW0089	32	31	30	29	to	21	20	19	18	17	SW008A	48	47	46	45	to	37	36	35	34	33	SW008B	64	63	62	61	to	53	52	51	50	49	○	○	○	○	○	○	○	○
	b15	b14	b13	b12	to	b4	b3	b2	b1	b0																																																							
SW0088	16	15	14	13	to	5	4	3	2	1																																																							
SW0089	32	31	30	29	to	21	20	19	18	17																																																							
SW008A	48	47	46	45	to	37	36	35	34	33																																																							
SW008B	64	63	62	61	to	53	52	51	50	49																																																							

* 2: Valid only when SB0047 is off. When it turns on (error), the last data are retained.

* 10: Minor errors are the type of errors that do not affect the CPU operation. (Refer to Section 8.3.3.)

Table 3 Link special register (SW) list (Continued)

No.	Name	Description	Availability																																																														
			Control station		Normal station		Remote master station		Remote I/O station																																																								
*2 SW008C (140) SW008D (141) SW008E (142) SW008F (143)	Power supply status of each station	<p>Indicates whether external power supply is available to each station (For QJ71LP21-25, 0 is ON.)</p> <p>Valid only for stations registered as normal in the SW0070 to SW0073.</p> <p>0: Without external power supply (Including stations reserved or numbered greater than the maximum)</p> <p>1: With external power supply</p> <table border="1"> <thead> <tr> <th></th> <th>b15</th> <th>b14</th> <th>b13</th> <th>b12</th> <th>to</th> <th>b4</th> <th>b3</th> <th>b2</th> <th>b1</th> <th>b0</th> </tr> </thead> <tbody> <tr> <td>SW008C</td> <td>16</td> <td>15</td> <td>14</td> <td>13</td> <td>to</td> <td>5</td> <td>4</td> <td>3</td> <td>2</td> <td>1</td> </tr> <tr> <td>SW008D</td> <td>32</td> <td>31</td> <td>30</td> <td>29</td> <td>to</td> <td>21</td> <td>20</td> <td>19</td> <td>18</td> <td>17</td> </tr> <tr> <td>SW008E</td> <td>48</td> <td>47</td> <td>46</td> <td>45</td> <td>to</td> <td>37</td> <td>36</td> <td>35</td> <td>34</td> <td>33</td> </tr> <tr> <td>SW008F</td> <td>64</td> <td>63</td> <td>62</td> <td>61</td> <td>to</td> <td>53</td> <td>52</td> <td>51</td> <td>50</td> <td>49</td> </tr> </tbody> </table> <p>Numbers 1 to 64 in the above table indicate the station numbers.</p>		b15	b14	b13	b12	to	b4	b3	b2	b1	b0	SW008C	16	15	14	13	to	5	4	3	2	1	SW008D	32	31	30	29	to	21	20	19	18	17	SW008E	48	47	46	45	to	37	36	35	34	33	SW008F	64	63	62	61	to	53	52	51	50	49	○	×	○	×	○	×	×	×
	b15	b14	b13	b12	to	b4	b3	b2	b1	b0																																																							
SW008C	16	15	14	13	to	5	4	3	2	1																																																							
SW008D	32	31	30	29	to	21	20	19	18	17																																																							
SW008E	48	47	46	45	to	37	36	35	34	33																																																							
SW008F	64	63	62	61	to	53	52	51	50	49																																																							
SW0090 (144)	Loopback information	<p>Stores the loop status of the host.</p> <p>0: Loop normal</p> <p>1: Forward loop error</p> <p>2: Reverse loop error</p> <p>3: Loopback</p> <p>4: Data linking disabled</p>	○	×	○	×	○	×	○	×																																																							
*2 SW0091 (145)/ SW0092 (146)/ SW0093 (147)/ SW0094 (148)	Forward loop status of each station	<p>Stores the forward loop status of each station (including the host).</p> <p>0: Normal (including the station with the maximum station number and smaller stations as well as reserved stations)</p> <p>1: Abnormal</p> <p>Disconnected station remains in the status when it was disconnected.</p> <table border="1"> <thead> <tr> <th></th> <th>b15</th> <th>b14</th> <th>b13</th> <th>b12</th> <th>to</th> <th>b4</th> <th>b3</th> <th>b2</th> <th>b1</th> <th>b0</th> </tr> </thead> <tbody> <tr> <td>SW0091</td> <td>16</td> <td>15</td> <td>14</td> <td>13</td> <td>to</td> <td>5</td> <td>4</td> <td>3</td> <td>2</td> <td>1</td> </tr> <tr> <td>SW0092</td> <td>32</td> <td>31</td> <td>30</td> <td>29</td> <td>to</td> <td>21</td> <td>20</td> <td>19</td> <td>18</td> <td>17</td> </tr> <tr> <td>SW0093</td> <td>48</td> <td>47</td> <td>46</td> <td>45</td> <td>to</td> <td>37</td> <td>36</td> <td>35</td> <td>34</td> <td>33</td> </tr> <tr> <td>SW0094</td> <td>64</td> <td>63</td> <td>62</td> <td>61</td> <td>to</td> <td>53</td> <td>52</td> <td>51</td> <td>50</td> <td>49</td> </tr> </tbody> </table> <p>Numbers 1 to 64 in the above table indicate the station numbers.</p>		b15	b14	b13	b12	to	b4	b3	b2	b1	b0	SW0091	16	15	14	13	to	5	4	3	2	1	SW0092	32	31	30	29	to	21	20	19	18	17	SW0093	48	47	46	45	to	37	36	35	34	33	SW0094	64	63	62	61	to	53	52	51	50	49	○	×	○	×	○	×	○	×
	b15	b14	b13	b12	to	b4	b3	b2	b1	b0																																																							
SW0091	16	15	14	13	to	5	4	3	2	1																																																							
SW0092	32	31	30	29	to	21	20	19	18	17																																																							
SW0093	48	47	46	45	to	37	36	35	34	33																																																							
SW0094	64	63	62	61	to	53	52	51	50	49																																																							

*2: Valid only when SB0047 is off. When it turns on (error), the last data are retained.

Table 3 Link special register (SW) list (Continued)

No.	Name	Description	Availability																																																													
			Control station		Normal station		Remote master station		Remote I/O station																																																							
			Optical	Coaxial	Optical	Coaxial	Optical	Coaxial	Optical	Coaxial																																																						
*2 SW0095 (149)/ SW0096 (150)/ SW0097 (151)/ SW0098 (152)	Reverse loop status of each station	Stores the reverse loop status of each station (including the host). 0: Normal (including the stations with the maximum station number and smaller numbers as well as reserved stations) 1: Abnormal Disconnected station remains in the status when it was disconnected. <table border="1"> <tr> <td>b15</td><td>b14</td><td>b13</td><td>b12</td><td>to</td><td>b4</td><td>b3</td><td>b2</td><td>b1</td><td>b0</td> </tr> <tr> <td>SW0095</td><td>16</td><td>15</td><td>14</td><td>13</td><td>to</td><td>5</td><td>4</td><td>3</td><td>2</td><td>1</td> </tr> <tr> <td>SW0096</td><td>32</td><td>31</td><td>30</td><td>29</td><td>to</td><td>21</td><td>20</td><td>19</td><td>18</td><td>17</td> </tr> <tr> <td>SW0097</td><td>48</td><td>47</td><td>46</td><td>45</td><td>to</td><td>37</td><td>36</td><td>35</td><td>34</td><td>33</td> </tr> <tr> <td>SW0098</td><td>64</td><td>63</td><td>62</td><td>61</td><td>to</td><td>53</td><td>52</td><td>51</td><td>50</td><td>49</td> </tr> </table> Numbers 1 to 64 in the above table indicate the station numbers.	b15	b14	b13	b12	to	b4	b3	b2	b1	b0	SW0095	16	15	14	13	to	5	4	3	2	1	SW0096	32	31	30	29	to	21	20	19	18	17	SW0097	48	47	46	45	to	37	36	35	34	33	SW0098	64	63	62	61	to	53	52	51	50	49	○	×	○	×	○	×	○	×
b15	b14	b13	b12	to	b4	b3	b2	b1	b0																																																							
SW0095	16	15	14	13	to	5	4	3	2	1																																																						
SW0096	32	31	30	29	to	21	20	19	18	17																																																						
SW0097	48	47	46	45	to	37	36	35	34	33																																																						
SW0098	64	63	62	61	to	53	52	51	50	49																																																						
*2 SW0099 (153)	Loopback station (forward loop side)	Stores the station number of which station is performing the loopback in the forward loop. 1 to 64 : Station No. 7DH : Remote master station	○	×	○	×	○	×	○	×	○	×																																																				
*2 SW009A (154)	Loopback station (reverse loop side)	Stores the station number of which station is performing the loopback in the reverse loop. 1 to 64 : Station No. 7DH : Remote master station	○	×	○	×	○	×	○	×	○	×																																																				
*2 SW009C (156)/ SW009D (157)/ SW009E (158)/ SW009F (159)	Loop usage status of each station	Stores the incorrect cable connection (IN-IN, OUT-OUT) status. (Refer to Section 8.2.10) All 0 or all 1: No incorrect connection of optical fiber cables Other than above: Incorrect connection of optical fiber cables <table border="1"> <tr> <td>b15</td><td>b14</td><td>b13</td><td>b12</td><td>to</td><td>b4</td><td>b3</td><td>b2</td><td>b1</td><td>b0</td> </tr> <tr> <td>SW009C</td><td>16</td><td>15</td><td>14</td><td>13</td><td>to</td><td>5</td><td>4</td><td>3</td><td>2</td><td>1</td> </tr> <tr> <td>SW009D</td><td>32</td><td>31</td><td>30</td><td>29</td><td>to</td><td>21</td><td>20</td><td>19</td><td>18</td><td>17</td> </tr> <tr> <td>SW009E</td><td>48</td><td>47</td><td>46</td><td>45</td><td>to</td><td>37</td><td>36</td><td>35</td><td>34</td><td>33</td> </tr> <tr> <td>SW009F</td><td>64</td><td>63</td><td>62</td><td>61</td><td>to</td><td>53</td><td>52</td><td>51</td><td>50</td><td>49</td> </tr> </table> Numbers 1 to 64 in the above table indicate the station numbers.	b15	b14	b13	b12	to	b4	b3	b2	b1	b0	SW009C	16	15	14	13	to	5	4	3	2	1	SW009D	32	31	30	29	to	21	20	19	18	17	SW009E	48	47	46	45	to	37	36	35	34	33	SW009F	64	63	62	61	to	53	52	51	50	49	○	×	○	×	○	×	○	×
b15	b14	b13	b12	to	b4	b3	b2	b1	b0																																																							
SW009C	16	15	14	13	to	5	4	3	2	1																																																						
SW009D	32	31	30	29	to	21	20	19	18	17																																																						
SW009E	48	47	46	45	to	37	36	35	34	33																																																						
SW009F	64	63	62	61	to	53	52	51	50	49																																																						
SW00A8 (168)	Online test execution item/faulty station (requesting side)	Stores both the online test item requested by the requesting station and the faulty station. (Valid when the SB00A9 is on.) Stations disconnected from the network are not included among the faulty stations because there is no response. <table border="1"> <tr> <td>b15</td><td>to</td><td>b8</td><td>b7</td><td>to</td><td>b0</td> </tr> <tr> <td>SW00A8</td><td></td><td>to</td><td></td><td>to</td><td></td> </tr> </table> Faulty station number Test item number When there are multiple faulty stations, the station number detected first is stored. 10H: Loop test 20H: Setup confirmation test 30H: Station order check test 40H: Communication test	b15	to	b8	b7	to	b0	SW00A8		to		to		○	○	○	○	○	○	○	○																																										
b15	to	b8	b7	to	b0																																																											
SW00A8		to		to																																																												
SW00A9 (169)	Online test result (requesting side)	Stores the online result on the requesting side. (Valid when the SB00A9 is on.) 0 : Test normal Other than 0 : Test error content (refer to the error codes in Section 8.3)	○	○	○	○	○	○	○	○	○	○																																																				

*2: Valid only when SB0047 is off. When it turns on (error), the last data are retained.

Table 3 Link special register (SW) list (Continued)

No.	Name	Description	Availability							
			Control station		Normal station		Remote master station		Remote I/O station	
			Optical	Coaxial	Optical	Coaxial	Optical	Coaxial	Optical	Coaxial
SW00AA (170)	Online test execution item (responding side)	<p>Stores the online test items on the responding side. (Valid when the SB00AB is on.) Stations disconnected from the network are not included among the faulty stations because there is no response.</p> <div style="text-align: center;"> </div> <p>10H: Loop test 20H: Setup confirmation test 30H: Station order check test 40H: Communication test</p>	○	○	○	○	○	○	○	○
SW00AB (171)	Online test result (responding side)	<p>Stores the online test result of the responding side. (Valid when the SB00AB is on.) 0 : Test normal Other than 0 : Test error content (refer to the error codes in Section 8.3)</p>	○	○	○	○	○	○	○	○
SW00AC (172)	Offline test execution item/faulty station (requesting side)	<p>Stores the offline test items and faulty station on the requesting side. (Valid when the SB00AD is on.) Stations disconnected from the network are not included among the faulty stations because there is no response. Any given station number (0 to 64, 7D_H) is saved in the maximum faulty station number (b8 to b15) for the loop test.</p> <div style="text-align: center;"> </div> <p>3: Loop test (forward loop) 4: Loop test (reverse loop) 5: Station-to-station test (master station) 6: Station-to-station test (slave station) 7: Self-loopback test 8: Internal self-loopback test</p> <p>The maximum faulty station number (b8 to b15) is enabled when Offline test completion (SB00AD) is on.</p>	○	○	○	○	○	○	○	○
SW00AD (173)	Offline test result (requesting side)	<p>Stores the offline result of the requesting side. (Valid when the SB00AD is on.) 0 : Test normal Other than 0 : Test error content (refer to the error codes in Section 8.3)</p>	○	○	○	○	○	○	○	○
SW00AE (174)	Offline test execution item (responding side)	<p>Stores the request-side offline test items and error stations. (Enabled when SB00AF is on.) When station breaks from network, it is not included with error stations because there is no response.</p> <div style="text-align: center;"> </div> <p>3: Loop test (forward loop) 4: Loop test (reverse loop)</p>	○	○	○	○	○	○	○	○
SW00AF (175)	Offline test result (responding side)	<p>Stores results of request-side offline test. (Enabled when SB00AF is on.) 0 : Test normal Other than 0 : Test error content (refer to the error codes in Section 8.3)</p>	○	○	○	○	○	○	○	○

Table 3 Link special register (SW) list (Continued)

No.	Name	Description	Availability																																																									
			Control station		Normal station		Remote master station		Remote I/O station																																																			
			Optical	Coaxial	Optical	Coaxial	Optical	Coaxial	Optical	Coaxial																																																		
*2 SW00B0 (176)/ SW00B1 (177)/ SW00B2 (178)/ SW00B3 (179)	Multiplex transmission status (1)	Stores each station's forward loop usage status during multiplex transmission. 0: Uses other than the forward loop 1: Uses the forward loop <table border="1"> <tr> <td>b15</td><td>b14</td><td>b13</td><td>b12</td><td>to</td><td>b4</td><td>b3</td><td>b2</td><td>b1</td><td>b0</td> </tr> <tr> <td>16</td><td>15</td><td>14</td><td>13</td><td>to</td><td>5</td><td>4</td><td>3</td><td>2</td><td>1</td> </tr> <tr> <td>32</td><td>31</td><td>30</td><td>29</td><td>to</td><td>21</td><td>20</td><td>19</td><td>18</td><td>17</td> </tr> <tr> <td>48</td><td>47</td><td>46</td><td>45</td><td>to</td><td>37</td><td>36</td><td>35</td><td>34</td><td>33</td> </tr> <tr> <td>64</td><td>63</td><td>62</td><td>61</td><td>to</td><td>53</td><td>52</td><td>51</td><td>50</td><td>49</td> </tr> </table> <small>Numbers 1 to 64 in the above table indicate the station numbers.</small>	b15	b14	b13	b12	to	b4	b3	b2	b1	b0	16	15	14	13	to	5	4	3	2	1	32	31	30	29	to	21	20	19	18	17	48	47	46	45	to	37	36	35	34	33	64	63	62	61	to	53	52	51	50	49	○	×	○	×	○	×	○	×
b15	b14	b13	b12	to	b4	b3	b2	b1	b0																																																			
16	15	14	13	to	5	4	3	2	1																																																			
32	31	30	29	to	21	20	19	18	17																																																			
48	47	46	45	to	37	36	35	34	33																																																			
64	63	62	61	to	53	52	51	50	49																																																			
*2 SW00B4 (180)/ SW00B5 (181)/ SW00B6 (182)/ SW00B7 (183)	Multiplex transmission status (2)	Stores each station's reverse loop usage status during multiplex transmission. 0: Uses other than the reverse loop 1: Uses the reverse loop <table border="1"> <tr> <td>b15</td><td>b14</td><td>b13</td><td>b12</td><td>to</td><td>b4</td><td>b3</td><td>b2</td><td>b1</td><td>b0</td> </tr> <tr> <td>16</td><td>15</td><td>14</td><td>13</td><td>to</td><td>5</td><td>4</td><td>3</td><td>2</td><td>1</td> </tr> <tr> <td>32</td><td>31</td><td>30</td><td>29</td><td>to</td><td>21</td><td>20</td><td>19</td><td>18</td><td>17</td> </tr> <tr> <td>48</td><td>47</td><td>46</td><td>45</td><td>to</td><td>37</td><td>36</td><td>35</td><td>34</td><td>33</td> </tr> <tr> <td>64</td><td>63</td><td>62</td><td>61</td><td>to</td><td>53</td><td>52</td><td>51</td><td>50</td><td>49</td> </tr> </table> <small>Numbers 1 to 64 in the above table indicate the station numbers.</small>	b15	b14	b13	b12	to	b4	b3	b2	b1	b0	16	15	14	13	to	5	4	3	2	1	32	31	30	29	to	21	20	19	18	17	48	47	46	45	to	37	36	35	34	33	64	63	62	61	to	53	52	51	50	49	○	×	○	×	○	×	○	×
b15	b14	b13	b12	to	b4	b3	b2	b1	b0																																																			
16	15	14	13	to	5	4	3	2	1																																																			
32	31	30	29	to	21	20	19	18	17																																																			
48	47	46	45	to	37	36	35	34	33																																																			
64	63	62	61	to	53	52	51	50	49																																																			
*3 SW00B8 (184)	UNDER on the forward loop side/coaxial bus UNDER	Accumulates and stores the number of "UNDER" errors on the forward loop side for the optical loop, or the number of "UNDER" errors of the coaxial bus for the coaxial bus. Other than 0: Number of errors Turning ON Clear communication error count (SB0006) clears the stored value.	○	○	○	○	○	○	○	○	○																																																	
*3 SW00B9 (185)	CRC on the forward loop side/coaxial bus CRC	Accumulates and stores the number of "CRC" errors on the forward loop side for the optical loop, or the number of "CRC" errors of the coaxial bus for the coaxial bus. Other than 0: Number of errors Turning ON Clear communication error count (SB0006) clears the stored value.	○	○	○	○	○	○	○	○	○																																																	
*3 SW00BA (186)	OVER on the forward loop side/coaxial bus OVER	Accumulates and stores the number of "OVER" errors on the forward loop side for the optical loop, or the number of "OVER" errors of the coaxial bus for the coaxial bus. Other than 0: Number of errors Turning ON Clear communication error count (SB0006) clears the stored value.	○	○	○	○	○	○	○	○	○																																																	
*3 SW00BB (187)	Short frame on the forward loop side/coaxial bus short frame	Accumulates and stores the number of "short frame" errors on the forward loop side for the optical loop, or the number of "short frame" errors of the coaxial bus for the coaxial bus. Other than 0: Number of errors Turning ON Clear communication error count (SB0006) clears the stored value.	○	○	○	○	○	○	○	○	○																																																	
*3 SW00BC (188)	Abort on the forward loop side (AB, IF)/coaxial bus abort (AB, IF)	Accumulates and stores the number of "AB, IF" errors on the forward loop side for the optical loop, or the number of "AB, IF" errors of the coaxial bus for the coaxial bus. Other than 0: Number of errors Turning ON Clear communication error count (SB0006) clears the stored value.	○	○	○	○	○	○	○	○	○																																																	

*2: Valid only when SB0047 is off. When it turns on (error), the last data are retained.

*3: To reset the SW00B8 to SW00C7, turn on the SB0006.

The number of times information stored in the SW00B8 to SW00C7 will not cause any problems if they are counted up gradually over a long period of time. If they are counted up rapidly in a short period of time (while monitoring with GX Developer, etc.), the cable may be faulty.

Table 3 Link special register (SW) list (Continued)

No.	Name	Description	Availability								
			Control station		Normal station		Remote master station		Remote I/O station		
			Optical	Coaxial	Optical	Coaxial	Optical	Coaxial	Optical	Coaxial	
*3 SW00BD (189)	Timeout on the forward loop side (TIME)/ coaxial bus timeout (TIME)	Accumulates and stores the number of "TIME" errors on the forward loop side for the optical loop, or the number of "TIME" errors of the coaxial bus for the coaxial bus. Other than 0: Number of errors Turning ON Clear communication error count (SB0006) clears the stored value.	○	○	○	○	○	○	○	○	○
*3 SW00BE (190)	Receiving 2k bytes or more on forward loop side (DATA)/coaxial bus receiving 2k bytes or more (DATA)	Accumulates and stores the number of "DATA" errors on the forward loop side for the optical loop, or the number of "DATA" errors of the coaxial bus for the coaxial bus. Other than 0: Number of errors Turning ON Clear communication error count (SB0006) clears the stored value.	○	○	○	○	○	○	○	○	○
*3 SW00BF (191)	DPLL error on the forward loop side/coaxial bus DPLL error	Accumulates and stores the number of "DPLL" errors on the forward loop side for the optical loop, or the number of "DPLL" errors of the coaxial bus for the coaxial bus. Other than 0: Number of errors Turning ON Clear communication error count (SB0006) clears the stored value.	○	○	○	○	○	○	○	○	○
*3 SW00C0 (192)	UNDER on the reverse loop side	Accumulates and stores the number of "UNDER" errors on the reverse loop side. Other than 0: Number of errors Turning ON Clear communication error count (SB0006) clears the stored value.	○	×	○	×	○	×	○	×	×
*3 SW00C1 (193)	CRC on the reverse loop side	Accumulates and stores the number of "CRC" errors on the reverse loop side. Other than 0: Number of errors Turning ON Clear communication error count (SB0006) clears the stored value.	○	×	○	×	○	×	○	×	×
*3 SW00C2 (194)	OVER on the reverse loop side	Accumulates and stores the number of "OVER" errors on the reverse loop side. Other than 0: Number of errors Turning ON Clear communication error count (SB0006) clears the stored value.	○	×	○	×	○	×	○	×	×
*3 SW00C3 (195)	Short frame on the reverse loop side	Accumulates and stores the number of "Short frame" errors on the reverse loop side. Other than 0: Number of errors Turning ON Clear communication error count (SB0006) clears the stored value.	○	×	○	×	○	×	○	×	×
*3 SW00C4 (196)	Abort on the reverse loop side (AB, IF)	Accumulates and stores the number of "AB.IF" errors on the reverse loop side. Other than 0: Number of errors Turning ON Clear communication error count (SB0006) clears the stored value.	○	×	○	×	○	×	○	×	×
*3 SW00C5 (197)	Timeout on the reverse loop side (TIME)	Accumulates and stores the number of "TIME" errors on the reverse loop side. Other than 0: Number of errors Turning ON Clear communication error count (SB0006) clears the stored value.	○	×	○	×	○	×	○	×	×
*3 SW00C6 (198)	Receiving 2k bytes or more on reverse loop side (DATA)	Accumulates and stores the number of "DATA" errors on the reverse loop side. Other than 0: Number of errors Turning ON Clear communication error count (SB0006) clears the stored value.	○	×	○	×	○	×	○	×	×
*3 SW00C7 (199)	DPLL error on reverse loop side	Accumulates and stores the number of "DPLL" errors on the reverse loop side. Other than 0: Number of errors Turning ON Clear communication error count (SB0006) clears the stored value.	○	×	○	×	○	×	○	×	×

* 3: To reset from the SW00B8 to C7, turn on the SB0006.

The numbers of times stored in the SW00B8 to SW00C7 will not cause any problems if they are counting up gradually over a long period of time. If they are counted up rapidly in a short period of time (while monitoring with GX Developer, etc.), the cable may be faulty.

Table 3 Link special register (SW) list (Continued)

No.	Name	Description	Availability							
			Control station		Normal station		Remote master station		Remote I/O station	
			Optical	Coaxial	Optical	Coaxial	Optical	Coaxial	Optical	Coaxial
* 4 SW00C8 (200)	Number of retries on the forward loop side/ coaxial bus retries error	Accumulates and stores the number of retries on the forward loop side for the optical loop, or the number of retries of the coaxial bus for the coaxial bus. Other than 0: Number of errors Turning ON Clear retry count (SB0005) clears the stored value.	○	○	○	○	○	○	○	○
* 4 SW00C9 (201)	Number of retries on the reverse loop side	Accumulates and stores the number of retries on the reverse loop side. Other than 0: Number of errors Turning ON Clear retry count (SB0005) clears the stored value.	○	×	○	×	○	×	○	×
* 5 SW00CC (204)	Line error on the forward loop side	Accumulates and stores the number of detected line errors on the forward loop side. Other than 0: Number of detected line errors Turning ON Clear forward loop transmission errors (SB0007) clears the stored value.	○	×	○	×	○	×	○	×
* 6 SW00CD (205)	Line error on the reverse loop side	Accumulates and stores the number of detected line errors on the reverse loop side. Other than 0: Number of detected line errors Turning ON Clear reverse loop transmission errors (SB0008) clears the stored value.	○	×	○	×	○	×	○	×
* 7 SW00CE (206)	Number of loop switches	Accumulates and stores the number of loop checks conducted. Other than 0: Number of loop switches Turning ON Clear loop switch count (SB0009) clears the stored value.	○	×	○	×	○	×	○	×
* 7 SW00CF (207)	Loop switch data pointer	Stores the pointer that indicates the next loop switch data. 0 to 15: Loop switch data (SW00D0 to SW00DF) Turning ON Clear loop switch count (SB0009) clears the stored value.	○	×	○	×	○	×	○	×

- * 4: This may be counted up at power on/reset, but it is not an error.
Clear with the SB0005 when the number of retries is not required before starting data linking.
- * 5: To reset the SW00CC, turn on the SB0007.
- * 6: To reset the SW00CD, turn on the SB0008.
- * 7: To reset the SW00CE to SW00E7, turn on the SB0009.

Table 3 Link special register (SW) list (Continued)

No.	Name	Description	Availability																																																														
			Control station		Normal station		Remote master station		Remote I/O station																																																								
			Optical	Coaxial	Optical	Coaxial	Optical	Coaxial	Optical	Coaxial																																																							
*7 SW00D0 (208) to SW00DF (223)	Loop switch data	<p>Stores the cause and status of the loop switch. Whether the data should be overwritten or retained is set in the common parameters.</p> <p><Cause> The bit corresponding to each error is set to 1.</p> <table border="0"> <tr> <td>All 0: Return direction</td> <td>< Status after the switching></td> </tr> <tr> <td>b0: Forward loop H/W error</td> <td>0: Multiplex transmission (Forward loop/reverse loop normal)</td> </tr> <tr> <td>b1: Reverse loop H/W error</td> <td>1: Data link by forward loop</td> </tr> <tr> <td>b2: Forward loop forced error</td> <td>2: Data linking by reverse loop</td> </tr> <tr> <td>b3: Reverse loop forced error</td> <td>3: Data linking by loopback</td> </tr> <tr> <td>b4: Forward loop continuous communication error</td> <td></td> </tr> <tr> <td>b5: Reverse loop continuous communication error</td> <td></td> </tr> <tr> <td>b6: Forward loop continuous line error</td> <td></td> </tr> <tr> <td>b7: Reverse loop continuous line error</td> <td></td> </tr> </table> <p>Turning ON Clear loop switch count (SB0009) clears the stored value.</p>	All 0: Return direction	< Status after the switching>	b0: Forward loop H/W error	0: Multiplex transmission (Forward loop/reverse loop normal)	b1: Reverse loop H/W error	1: Data link by forward loop	b2: Forward loop forced error	2: Data linking by reverse loop	b3: Reverse loop forced error	3: Data linking by loopback	b4: Forward loop continuous communication error		b5: Reverse loop continuous communication error		b6: Forward loop continuous line error		b7: Reverse loop continuous line error		○	×	○	×	○	×	○	×																																					
All 0: Return direction	< Status after the switching>																																																																
b0: Forward loop H/W error	0: Multiplex transmission (Forward loop/reverse loop normal)																																																																
b1: Reverse loop H/W error	1: Data link by forward loop																																																																
b2: Forward loop forced error	2: Data linking by reverse loop																																																																
b3: Reverse loop forced error	3: Data linking by loopback																																																																
b4: Forward loop continuous communication error																																																																	
b5: Reverse loop continuous communication error																																																																	
b6: Forward loop continuous line error																																																																	
b7: Reverse loop continuous line error																																																																	
*7 *8 SW00E0 (224) to SW00E7 (231)	Switch request station	<p>Turning ON Clear loop switch count (SB0009) clears the stored value.</p>	○	×	○	×	○	×	○	×																																																							
*2 SW00E8 (232) to SW00EB (235)	Module type of each station	<p>Stores each station's module type.</p> <p>0: MELSECNET/10 module 1: MELSECNET/H module</p> <table border="1"> <thead> <tr> <th></th> <th>b15</th> <th>b14</th> <th>b13</th> <th>b12</th> <th>to</th> <th>b4</th> <th>b3</th> <th>b2</th> <th>b1</th> <th>b0</th> </tr> </thead> <tbody> <tr> <td>SW00E8</td> <td>16</td> <td>15</td> <td>14</td> <td>13</td> <td>to</td> <td>5</td> <td>4</td> <td>3</td> <td>2</td> <td>1</td> </tr> <tr> <td>SW00E9</td> <td>32</td> <td>31</td> <td>30</td> <td>29</td> <td>to</td> <td>21</td> <td>20</td> <td>19</td> <td>18</td> <td>17</td> </tr> <tr> <td>SW00EA</td> <td>48</td> <td>47</td> <td>46</td> <td>45</td> <td>to</td> <td>37</td> <td>36</td> <td>35</td> <td>34</td> <td>33</td> </tr> <tr> <td>SW00EB</td> <td>64</td> <td>63</td> <td>62</td> <td>61</td> <td>to</td> <td>53</td> <td>52</td> <td>51</td> <td>50</td> <td>49</td> </tr> </tbody> </table> <p>Numbers 1 to 64 in the above table indicate the station numbers.</p>		b15	b14	b13	b12	to	b4	b3	b2	b1	b0	SW00E8	16	15	14	13	to	5	4	3	2	1	SW00E9	32	31	30	29	to	21	20	19	18	17	SW00EA	48	47	46	45	to	37	36	35	34	33	SW00EB	64	63	62	61	to	53	52	51	50	49	○	○	○	○	×	×	×	×
	b15	b14	b13	b12	to	b4	b3	b2	b1	b0																																																							
SW00E8	16	15	14	13	to	5	4	3	2	1																																																							
SW00E9	32	31	30	29	to	21	20	19	18	17																																																							
SW00EA	48	47	46	45	to	37	36	35	34	33																																																							
SW00EB	64	63	62	61	to	53	52	51	50	49																																																							
*2 SW00EC (236)	Low-speed cyclic transmission start execution results	<p>Stores execution results for low-speed cyclic transmission start execution results.</p> <p>0 : Test normal Other than 0 : Test error content (refer to the error codes in Section 8.3)</p>	○	○	○	○	×	×	×	×																																																							

* 2: Valid only when SB0047 is off. When it turns on (error), the last data are retained.

* 7: To reset the SW00CE to SW00E7, turn on the SB0009.

* 8: For the loop switch request station, stations other than the ones at both ends of the loop may be stored because the loop switch request is issued by the station that first detected the loop error.

Table 3 Link special register (SW) list (Continued)

No.	Name	Description	Availability								
			Control station		Normal station		Remote master station		Remote I/O station		
			Optical	Coaxial	Optical	Coaxial	Optical	Coaxial	Optical	Coaxial	
*9 SW00EE (238)	Transient transmission error	Accumulates and stores the number of transient transmission errors. Other than 0: Number of errors Turning ON Clear transient transmission errors (SB000A) clears the stored value.	○	○	○	○	○	○	○	○	○
*9 SW00EF (239)	Transient transmission error pointer	Stores the pointer that sets the data for the next transient transmission error. Turning ON Clear transient transmission errors (SB000A) clears the stored value.	○	○	○	○	○	○	○	○	○
*2 SW00F0 (240) to SW00FF (255)	Transient transmission error history	Stores the error codes of the transient transmission errors (refer to the error codes in Section 8.3).	○	○	○	○	○	○	○	○	○
*2 SW01C4 (452)	Remote sub-master station switching result	Stores the result of a shift from master operation to sub-master operation. 0 : Normal completion 1 or later : Abnormal completion (refer to Section 8.3 for error codes)	×	×	×	×	○	○	×	×	×
*2 SW01C8 (456)	Send LY device number	(Valid only when SB01C8 is ON) For remote master station : The send LY device number to the remote sub-master station is stored. In 1 point units. For remote sub-master station : The send LY device number to the remote master station is stored. In 1 point units.	×	×	×	×	○	○	×	×	×
*2 SW01C9 (457)	Receive LX device number	(Valid only when SB01C8 is ON) For remote master station : The receive LX device number from the remote sub-master station is stored. In 1 point units. For remote sub-master station : The receive LX device number from the remote master station is stored. In 1 point units.	×	×	×	×	○	○	×	×	×
*2 SW01CC (460)	Send LB device number	(Valid only when SB01C8 is ON) For remote master station : The send LB device number to the remote sub-master station is stored. In 1 point units. For remote sub-master station : The send LB device number to the remote master station is stored. In 1 point units.	×	×	×	×	○	○	×	×	×
*2 SW01CD (461)	Receive LB device number	(Valid only when SB01C8 is ON) For remote master station : The receive LB device number from the remote sub-master station is stored. In 1 point units. For remote sub-master station : The receive LB device number from the remote master station is stored. In 1 point units.	×	×	×	×	○	○	×	×	×
*2 SW01CE (462)	Send LW device number	(Valid only when SB01C8 is ON) For remote master station : The send LW device number to the remote sub-master station is stored. In 1 point units. For remote sub-master station : The send LW device number to the remote master station is stored. In 1 point units.	×	×	×	×	○	○	×	×	×
*2 SW01CF (463)	Receive LW device number	(Valid only when SB01C8 is ON) For remote master station : The receive LW device number from the remote sub-master station is stored. In 1 point units. For remote sub-master station : The receive LW device number from the remote master station is stored. In 1 point units.	×	×	×	×	○	○	×	×	×

*2: Valid only when SB0047 is off. When it turns on (error), the last data are retained.

*9: To reset the SW00EE to SW00EF, turn on the SB000A.

Table 3 Link special register (SW) list (Continued)

No.	Name	Description	Availability																																																														
			Control station		Normal station		Remote master station		Remote I/O station																																																								
			Optical	Coaxial	Optical	Coaxial	Optical	Coaxial	Optical	Coaxial																																																							
*2 SW01E0 (480)/ SW01E1 (481)/ SW01E2 (482)/ SW01E3 (483)	Network type consistency check	Indicates whether there is a mismatch between the network types of the control station and normal stations on the network. <ul style="list-style-type: none"> When the control station is in the MELSECNET/H Extended mode <ul style="list-style-type: none"> 0: Set to the MELSECNET/H Extended mode. (Including stations of station Nos. greater than the maximum, reserved stations and communication error stations) 1: Set to the MELSECNET/H mode or MELSECNET/10 mode. When the control station is in the MELSECNET/H mode or MELSECNET/10 mode <ul style="list-style-type: none"> 0: Set to the MELSECNET/H mode or MELSECNET/10 mode. (Including stations of station Nos. greater than the maximum, reserved stations and communication error stations) 1: Set to the MELSECNET/H Extended mode. 	○	○	○	○	×	×	×	×																																																							
		<table border="1"> <thead> <tr> <th></th> <th>b15</th> <th>b14</th> <th>b13</th> <th>b12</th> <th>to</th> <th>b4</th> <th>b3</th> <th>b2</th> <th>b1</th> <th>b0</th> </tr> </thead> <tbody> <tr> <td>SW01E0</td> <td>16</td> <td>15</td> <td>14</td> <td>13</td> <td>to</td> <td>5</td> <td>4</td> <td>3</td> <td>2</td> <td>1</td> </tr> <tr> <td>SW01E1</td> <td>32</td> <td>31</td> <td>30</td> <td>29</td> <td>to</td> <td>21</td> <td>20</td> <td>19</td> <td>18</td> <td>17</td> </tr> <tr> <td>SW01E2</td> <td>48</td> <td>47</td> <td>46</td> <td>45</td> <td>to</td> <td>37</td> <td>36</td> <td>35</td> <td>34</td> <td>33</td> </tr> <tr> <td>SW01E3</td> <td>64</td> <td>63</td> <td>62</td> <td>61</td> <td>to</td> <td>53</td> <td>52</td> <td>51</td> <td>50</td> <td>49</td> </tr> </tbody> </table> 1 to 64 in the table indicate the station Nos.		b15	b14	b13	b12	to	b4	b3	b2	b1	b0	SW01E0	16	15	14	13	to	5	4	3	2	1	SW01E1	32	31	30	29	to	21	20	19	18	17	SW01E2	48	47	46	45	to	37	36	35	34	33	SW01E3	64	63	62	61	to	53	52	51	50	49								
	b15	b14	b13	b12	to	b4	b3	b2	b1	b0																																																							
SW01E0	16	15	14	13	to	5	4	3	2	1																																																							
SW01E1	32	31	30	29	to	21	20	19	18	17																																																							
SW01E2	48	47	46	45	to	37	36	35	34	33																																																							
SW01E3	64	63	62	61	to	53	52	51	50	49																																																							
*2 SW01F4 (500)/ SW01F5 (501)/ SW01F6 (502)/ SW01F7 (503)	Redundant system status (1)	Indicates the operation mode of each station's CPU. <ul style="list-style-type: none"> 0: Backup mode (including the single CPU system) (including stations exceeding the maximum station number and reserved stations) 1: Separate mode 	○	○	○	○	×	×	×	×																																																							
		<table border="1"> <thead> <tr> <th></th> <th>b15</th> <th>b14</th> <th>b13</th> <th>b12</th> <th>to</th> <th>b4</th> <th>b3</th> <th>b2</th> <th>b1</th> <th>b0</th> </tr> </thead> <tbody> <tr> <td>SW01F4</td> <td>16</td> <td>15</td> <td>14</td> <td>13</td> <td>to</td> <td>5</td> <td>4</td> <td>3</td> <td>2</td> <td>1</td> </tr> <tr> <td>SW01F5</td> <td>32</td> <td>31</td> <td>30</td> <td>29</td> <td>to</td> <td>21</td> <td>20</td> <td>19</td> <td>18</td> <td>17</td> </tr> <tr> <td>SW01F6</td> <td>48</td> <td>47</td> <td>46</td> <td>45</td> <td>to</td> <td>37</td> <td>36</td> <td>35</td> <td>34</td> <td>33</td> </tr> <tr> <td>SW01F7</td> <td>64</td> <td>63</td> <td>62</td> <td>61</td> <td>to</td> <td>53</td> <td>52</td> <td>51</td> <td>50</td> <td>49</td> </tr> </tbody> </table> Numbers 1 to 64 in the above table indicate the station numbers.		b15	b14	b13	b12	to	b4	b3	b2	b1	b0	SW01F4	16	15	14	13	to	5	4	3	2	1	SW01F5	32	31	30	29	to	21	20	19	18	17	SW01F6	48	47	46	45	to	37	36	35	34	33	SW01F7	64	63	62	61	to	53	52	51	50	49								
	b15	b14	b13	b12	to	b4	b3	b2	b1	b0																																																							
SW01F4	16	15	14	13	to	5	4	3	2	1																																																							
SW01F5	32	31	30	29	to	21	20	19	18	17																																																							
SW01F6	48	47	46	45	to	37	36	35	34	33																																																							
SW01F7	64	63	62	61	to	53	52	51	50	49																																																							
*2 SW01F8 (504)/ SW01F9 (505)/ SW01FA (506)/ SW01FB (507)	Redundant system status (2)	Indicates the pairing setting status of each station. In the case of a redundant system, the bit of the station with the larger number is turned on (1). <ul style="list-style-type: none"> 0: No pairing designation (including the single CPU system) (including stations exceeding the maximum station number) 1: Station with pairing designation 	○	○	○	○	×	×	×	×																																																							
		<table border="1"> <thead> <tr> <th></th> <th>b15</th> <th>b14</th> <th>b13</th> <th>b12</th> <th>to</th> <th>b4</th> <th>b3</th> <th>b2</th> <th>b1</th> <th>b0</th> </tr> </thead> <tbody> <tr> <td>SW01F8</td> <td>16</td> <td>15</td> <td>14</td> <td>13</td> <td>to</td> <td>5</td> <td>4</td> <td>3</td> <td>2</td> <td>1</td> </tr> <tr> <td>SW01F9</td> <td>32</td> <td>31</td> <td>30</td> <td>29</td> <td>to</td> <td>21</td> <td>20</td> <td>19</td> <td>18</td> <td>17</td> </tr> <tr> <td>SW01FA</td> <td>48</td> <td>47</td> <td>46</td> <td>45</td> <td>to</td> <td>37</td> <td>36</td> <td>35</td> <td>34</td> <td>33</td> </tr> <tr> <td>SW01FB</td> <td>64</td> <td>63</td> <td>62</td> <td>61</td> <td>to</td> <td>53</td> <td>52</td> <td>51</td> <td>50</td> <td>49</td> </tr> </tbody> </table> Numbers 1 to 64 in the above table indicate the station numbers.		b15	b14	b13	b12	to	b4	b3	b2	b1	b0	SW01F8	16	15	14	13	to	5	4	3	2	1	SW01F9	32	31	30	29	to	21	20	19	18	17	SW01FA	48	47	46	45	to	37	36	35	34	33	SW01FB	64	63	62	61	to	53	52	51	50	49								
	b15	b14	b13	b12	to	b4	b3	b2	b1	b0																																																							
SW01F8	16	15	14	13	to	5	4	3	2	1																																																							
SW01F9	32	31	30	29	to	21	20	19	18	17																																																							
SW01FA	48	47	46	45	to	37	36	35	34	33																																																							
SW01FB	64	63	62	61	to	53	52	51	50	49																																																							
*2 SW01FC (508)/ SW01FD (509)/ SW01FE (510)/ SW01FF (511)	Redundant system status (3)	Indicates the operation status of each station's CPU (control system/standby system). <ul style="list-style-type: none"> 0: The host station CPU is on the control system (including the single CPU system) (including stations exceeding the maximum station number and reserved stations). 1: The host system CPU is on the standby system. 	○	○	○	○	×	×	×	×																																																							
		<table border="1"> <thead> <tr> <th></th> <th>b15</th> <th>b14</th> <th>b13</th> <th>b12</th> <th>to</th> <th>b4</th> <th>b3</th> <th>b2</th> <th>b1</th> <th>b0</th> </tr> </thead> <tbody> <tr> <td>SW01FC</td> <td>16</td> <td>15</td> <td>14</td> <td>13</td> <td>to</td> <td>5</td> <td>4</td> <td>3</td> <td>2</td> <td>1</td> </tr> <tr> <td>SW01FD</td> <td>32</td> <td>31</td> <td>30</td> <td>29</td> <td>to</td> <td>21</td> <td>20</td> <td>19</td> <td>18</td> <td>17</td> </tr> <tr> <td>SW01FE</td> <td>48</td> <td>47</td> <td>46</td> <td>45</td> <td>to</td> <td>37</td> <td>36</td> <td>35</td> <td>34</td> <td>33</td> </tr> <tr> <td>SW01FF</td> <td>64</td> <td>63</td> <td>62</td> <td>61</td> <td>to</td> <td>53</td> <td>52</td> <td>51</td> <td>50</td> <td>49</td> </tr> </tbody> </table> Numbers 1 to 64 in the above table indicate the station numbers.		b15	b14	b13	b12	to	b4	b3	b2	b1	b0	SW01FC	16	15	14	13	to	5	4	3	2	1	SW01FD	32	31	30	29	to	21	20	19	18	17	SW01FE	48	47	46	45	to	37	36	35	34	33	SW01FF	64	63	62	61	to	53	52	51	50	49								
	b15	b14	b13	b12	to	b4	b3	b2	b1	b0																																																							
SW01FC	16	15	14	13	to	5	4	3	2	1																																																							
SW01FD	32	31	30	29	to	21	20	19	18	17																																																							
SW01FE	48	47	46	45	to	37	36	35	34	33																																																							
SW01FF	64	63	62	61	to	53	52	51	50	49																																																							

*2: Valid only when SB0047 is off. When it turns on (error), the last data are retained.

Appendix 4 Special Relay (SM) for Remote I/O Stations

The special relay (SM) is an internal relay whose specification is fixed in the programmable controller. For this reason, the special relay cannot be used in the same way as other internal relays used in sequence programs. However, the bit of the special relay can be turned ON or OFF as needed to control the CPU module or the remote I/O module.

To monitor and turn ON or OFF the bit of the special relay of the remote I/O module, use GX Developer. Connect GX Developer to the remote master station or the remote I/O station to perform monitoring and device tests.

The list in this section provides only the special relay areas related to the remote I/O module. The following table shows how to read the special relay list.

Item	Description
Number	• Indicates the number of the special relay.
Name	• Indicates the name of the special relay.
Meaning	• Indicates the nature of the special relay.
Explanation	• Contains detailed information about the nature of the special relay.
Set by (When set)	<ul style="list-style-type: none"> • Indicates whether the relay is set by the system or user, and, if it is set by the system, when setting is performed. <Set by> <ul style="list-style-type: none"> S : Set by system U : Set by user (in sequence program or test operation at a peripheral device) S/U : Set by both system and user <When set> → indicated only if setting is done by system. <ul style="list-style-type: none"> Each END : Set during each END processing Initial : Set only during initial processing (when power supply is turned ON, or when going from STOP to RUN) Status change : Set only when there is a change in status Error : Set when error is generated Instruction execution : Set when instruction is executed Request : Set only when there is a user request (through SM, etc.) System switch : Set when the system is switched
Corresponding ACPU M9 <input type="checkbox"/> <input type="checkbox"/> <input type="checkbox"/>	<ul style="list-style-type: none"> • Indicates special relay M9 <input type="checkbox"/> <input type="checkbox"/> <input type="checkbox"/> corresponding to the ACPU. (Indicates M9 <input type="checkbox"/> <input type="checkbox"/> <input type="checkbox"/> format change when there has been a change in contents. Basic model QCPU and Redundant CPU are not supported.) • Items indicated as "New" have been newly added for Q/QnACPU
Applicable CPU	<ul style="list-style-type: none"> • Indicates the applicable CPU module. ○ : Can be applied to all types of QCPU and QnACPU QCPU: Can be applied to all Q-series CPU Q00J/Q00/Q01: Can be applied to Basic model QCPU Qn(H) : Can be applied to High Performance model QCPU QnPH : Can be applied to Process CPU QnPRH : Can be applied to Redundant CPU QnU : Can be applied to Universal model Q CPU QnA: Can be applied to QnA series and Q2ASCPU series Remote: Can be applied to the MELSECNET/H remote I/O modules. Each CPU module type name: Can be applied only to the specific CPU module. (e.g. Q4ARCPU, Q3ACPU)

For details on the following items, refer to the following.

- CPU → • User's Manual (Function Explanation, Program Fundamentals) for the CPU module used
- Networks → • Q corresponding MELSECNET/H Network System Reference Manual (PLC to PLC network)
 - Q corresponding MELSECNET/H Network System Reference Manual (Remote I/O network)
 - For QnA/Q4AR MELSECNET/10 Network System Reference Manual
- SFC → • MELSEC-Q/L/QnA Programming Manual (SFC)

(1) Diagnostic information
Special Relay List

Number	Name	Meaning	Explanation	Set by (When Set)	Corresponding ACPU M9 <input type="checkbox"/> <input type="checkbox"/> <input type="checkbox"/>	Corresponding CPU
SM0	Diagnostic errors	OFF: No error ON : Error	<ul style="list-style-type: none"> This relay turns on if an error is detected by diagnostics. (Also turns on if an error is detected by an annunciator or the CHK instruction.) This relay remains on even after the system returns to normal. 	S (Error)	New	QnA Qn(H) QnPH QnPRH Rem
			<ul style="list-style-type: none"> This relay turns on if an error is detected by diagnostics. (Also turns on if an error is detected by an annunciator.) This relay remains on even after the system returns to normal. 	S (Error)	New	Q00J/ Q00/Q01 QnU
SM1	Self-diagnostic error	OFF: No error ON : Error	<ul style="list-style-type: none"> This relay turns on if an error is detected by self-diagnostics. (Remains off if an error is detected by an annunciator or the CHK instruction.) This relay remains on even after the system returns to normal. 	S (Error)	M9008	QnA Qn(H) QnPH QnPRH Rem
			<ul style="list-style-type: none"> This relay turns on if an error is detected by self-diagnostics. (Remains off if an error is detected by an annunciator.) This relay remains on even after the system returns to normal. 	S (Error)	New	Q00J/ Q00/Q01 QnU
SM5	Error common information	OFF: No error common information ON : Error common information	<ul style="list-style-type: none"> This relay turns on if error common information data exists when SM0 turns on. 	S (Error)	New	○ Rem
SM16	Error individual information	OFF: No error individual information ON : Error individual information	<ul style="list-style-type: none"> This relay turns on if error individual information data exists when SM0 turns on. 	S (Error)	New	
SM50	Error reset	OFF →ON : Error reset	<ul style="list-style-type: none"> Conducts error reset operation. 	U	New	
SM60	Blown fuse detection	OFF: Normal ON : Module with blown fuse	<ul style="list-style-type: none"> This relay turns on if there is at least one output module whose fuse has blown. This relay remains on even after the system returns to normal. Output modules on remote I/O stations are also checked. 	S (Error)	M9000	○ Rem
SM61	I/O module verify error	OFF: Normal ON : Error	<ul style="list-style-type: none"> This relay turns on if the status of the I/O module differs from that registered at power-on. This relay remains on even after the system returns to normal. I/O modules on remote I/O stations are also checked. 	S (Error)	M9002	

(2) System information
Special Relay List

Number	Name	Meaning	Explanation	Set by (When Set)	Corresponding ACPU M9 <input type="checkbox"/> <input type="checkbox"/> <input type="checkbox"/>	Corresponding CPU
SM206	PAUSE enable coil	OFF: PAUSE disabled ON : PAUSE enabled	<ul style="list-style-type: none"> The status changes to PAUSE if this relay is on when the PAUSE contact turns on. 	U	M9040	○
	Device test request acceptance status	OFF: Test not executed ON : Test executed	<ul style="list-style-type: none"> This relay turns on when inputs/outputs are forcibly registered by GX Developer. 	S (Request)	New	Remote
SM213	Clock data read request	OFF: Ignored ON : Read request	<ul style="list-style-type: none"> This relay is turned on to read clock data and store them as BCD values into SD210 to SD213. 	U	M9028	○ Rem
SM250	Max. loaded I/O read	OFF: Ignored ON : Read	<ul style="list-style-type: none"> When this relay turns on, the largest I/O number among those of the mounted modules is read into SD250. 	U	New	QnA Qn(H) QnPH QnPRH Rem
SM280	CC-Link error	OFF: Normal ON : Error	<ul style="list-style-type: none"> Turns on if a CC-Link error is detected in any of the CC-Link modules mounted. Turns off when the condition returns to normal. 	S (Status change)	New	Qn(H) QnPH QnPRH Rem
			<ul style="list-style-type: none"> Turns on if a CC-Link error is detected in any of the CC-Link modules mounted. Remains on even after the condition returns to normal. 	S (Error)	New	QnA

(3) Scan information
Special Relay List

Number	Name	Meaning	Explanation	Set by (When Set)	Corresponding ACPU	Corresponding CPU
					M9 <input type="checkbox"/> <input type="checkbox"/> <input type="checkbox"/>	
SM551	Reads module service interval	OFF: Ignored ON : Read	<ul style="list-style-type: none"> When this relay is turned on, the service interval of the module specified by SD550 is read to SD551 and SD552. 	U	New	QnA Qn(H) QnPH QnPRH Rem

(4) Redundant power supply module information
Special Relay List

Number	Name	Meaning	Explanation	Set by (When Set)	Corresponding ACPU	Corresponding CPU
					M9 <input type="checkbox"/> <input type="checkbox"/> <input type="checkbox"/>	
SM 1780	Power supply off detection flag	OFF: No redundant power supply module with input power OFF detected ON : Redundant power supply module with input power OFF detected	<ul style="list-style-type: none"> Turns on when one or more redundant power supply modules with input power off are detected. Turns on if any of SD1780 bits is on. Turns off if all bits of SD1780 are off. This relay turns off when the main base unit is not a redundant main base unit (Q3□RB). When the multiple CPU system is configured, the flags are stored only to the CPU No.1. 	S (Each END)	New	Qn(H) ^{*2} QnPH ^{*2} QnPRH Rem
SM 1781	Power supply failure detection flag	OFF: No faulty redundant power supply module detected ON : Faulty redundant power supply module detected	<ul style="list-style-type: none"> Turns on when one or more faulty redundant power supply modules are detected. Turns on if any of SD1781 bits is on. Turns off if all bits of SD1781 are off. This relay turns off when the main base unit is not a redundant main base unit (Q3□RB). When the multiple CPU system is configured, the flags are stored only to the CPU No.1. 	S (Each END)		
SM 1782	Momentary power failure detection flag for power supply 1 ^{*1}	OFF: No momentary power failure detected ON : Momentary power failure detected	<ul style="list-style-type: none"> Turns on when a momentary power failure of the input power supply to the power supply 1 or 2 is detected one or more times. After turning on, this relay remains on even if the power supply recovers from the momentary power failure. Turns off the flags (SM1782 and SM1783) of the power supply 1 and 2 when the CPU module starts. When the input power to one of the redundant power supply modules turns off, the corresponding flag turns off. This relay turns off when the main base unit is not a redundant main base unit (Q3□RB). When the multiple CPU system is configured, the flags are stored only to the CPU No.1. 	S (Each END)		
SM 1783	Momentary power failure detection flag for power supply 2 ^{*1}					

*1: The "power supply 1" indicates the redundant power supply module mounted on the POWER 1 slot of the redundant base unit (Q3□RB/Q6□RB/Q6□WRB). The "power supply 2" indicates the redundant power supply module mounted on the POWER 2 slot of the redundant base unit (Q3□RB/Q6□RB/Q6□WRB).

*2: This applies to modules with a serial number (first five digits) of "07032" or later.

In multiple CPU systems, all CPU modules used in a system must be the ones with a serial number (first five digits) of "07032" or later.

Appendix 5 Special Register (SD) for Remote I/O Module

The special register (SD) is an internal register whose application is fixed in the programmable controller. For this reason, the special register cannot be used in the same way as other internal registers used in sequence programs. However, data can be written to the special register to control the CPU module or the remote I/O module as needed.

Data is stored in binary format if not specified.

To monitor and write data to the special register of the remote I/O module, use GX Developer or the READ/WRITE instructions in the sequence program.

Connect GX Developer to the remote master station or remote I/O station to perform monitoring and device tests. With the sequence program, execute the READ instruction to read data from the special register and execute the WRITE instruction to write data to the special register.

The list in this section provides only the special register areas related to the remote I/O module. The following table shows how to read the special register list.

Item	Description
Number	• Indicates special register number
Name	• Indicates name of special register
Meaning	• Indicates contents of special register
Explanation	• Discusses contents of special register in more detail
Set by (When set)	<ul style="list-style-type: none"> • Indicates whether the relay is set by the system or user, and, if it is set by the system, when setting is performed. <Set by> <ul style="list-style-type: none"> S : Set by system U : Set by user (sequence programs or test operations from peripheral devices) S/U : Set by both system and user <When set> → Indicated only for registers set by system <ul style="list-style-type: none"> Each END : Set during each END processing Initial : Set only during initial processing (when power supply is turned ON, or when going from STOP to RUN) Status change : Set only when there is a change in status Error : Set when error occurs Instruction execution : Set when instruction is executed Request : Set only when there is a user request (through SM, etc.) System switch : Set when the system is switched
Corresponding ACPU M9 <input type="checkbox"/> <input type="checkbox"/> <input type="checkbox"/>	<ul style="list-style-type: none"> • Indicates corresponding special register in ACPU (D9 <input type="checkbox"/> <input type="checkbox"/> <input type="checkbox"/>)(Indicates M9 <input type="checkbox"/> <input type="checkbox"/> <input type="checkbox"/> format change when there has been a change in contents. Basic model QCPU and Redundant CPU are not supported) • Items indicated as "New" have been newly added for QnACPU
Applicable CPU	<ul style="list-style-type: none"> • Indicates the applicable CPU module. ○ : Can be applied to all types of QCPU and QnACPU QCPU: Can be applied to all Q-series CPU Q00J/Q00/Q01: Can be applied to Basic model QCPU Qn(H) : Can be applied to High Performance model QCPU QnPH : Can be applied to Process CPU QnPRH : Can be applied to Redundant QCPU QnU : Can be applied to Universal model QCPU QnA: Can be applied to QnA series and Q2ASCPU series Rem: Can be applied to the MELSECNET/H remote I/O modules. Each CPU module type name: Can be applied only to the specific CPU module. (e.g. Q4ARCPU, Q3ACPU)

For details on the following items, refer to the following.

- CPU → • User's Manual (Function Explanation, Program Fundamentals) of the CPU module used
- Networks → • Q corresponding MELSECNET/H Network System Reference Manual (PLC to PLC network)
- Q corresponding MELSECNET/H Network System Reference Manual (Remote I/O network)
- For QnA/Q4AR MELSECNET/10 Network System Reference Manual
- SFC → • MELSEC-Q/L/QnA Programming Manual (SFC)

(1) Diagnostic information
Special Register List

Number	Name	Meaning	Explanation	Set by (When set)	Corresponding ACPU D9□□□	Corresponding CPU									
SD0	Diagnostic errors	Diagnostic error code	<ul style="list-style-type: none"> This register stores the error code of an error detected by diagnostics. Contents identical to latest error history information. 	S (Error)	D9008 format change										
SD1	Clock time for diagnosis error occurrence	Clock time for diagnosis error occurrence	<ul style="list-style-type: none"> This register stores the year (last two digits) and the month when the SD0 data is updated in 2-digit BCD. <p>(Example)</p> <table border="1"> <tr> <td>B15 to B8</td> <td>B7 to B0</td> <td></td> </tr> <tr> <td>Year (0 to 99)</td> <td>Month (1 to 12)</td> <td>: October, 1995</td> </tr> <tr> <td colspan="2"></td> <td>H9510</td> </tr> </table>	B15 to B8	B7 to B0		Year (0 to 99)	Month (1 to 12)	: October, 1995			H9510	S (Error)	New	
B15 to B8			B7 to B0												
Year (0 to 99)			Month (1 to 12)	: October, 1995											
		H9510													
SD2	<ul style="list-style-type: none"> This register stores the day and the hour when the SD0 data is updated in 2-digit BCD. <p>(Example)</p> <table border="1"> <tr> <td>B15 to B8</td> <td>B7 to B0</td> <td></td> </tr> <tr> <td>Day (1 to 31)</td> <td>Hour (0 to 23)</td> <td>: 10 p.m. on 25th</td> </tr> <tr> <td colspan="2"></td> <td>H2510</td> </tr> </table>	B15 to B8	B7 to B0		Day (1 to 31)	Hour (0 to 23)	: 10 p.m. on 25th			H2510					
B15 to B8	B7 to B0														
Day (1 to 31)	Hour (0 to 23)	: 10 p.m. on 25th													
		H2510													
SD3	<ul style="list-style-type: none"> This register stores the minute and the second when the SD0 data is updated in 2-digit BCD. <p>(Example)</p> <table border="1"> <tr> <td>B15 to B8</td> <td>B7 to B0</td> <td></td> </tr> <tr> <td>Minutes (0 to 59)</td> <td>Seconds (0 to 59)</td> <td>: 35 min. 48 sec. (past the hour)</td> </tr> <tr> <td colspan="2"></td> <td>H3548</td> </tr> </table>	B15 to B8	B7 to B0		Minutes (0 to 59)	Seconds (0 to 59)	: 35 min. 48 sec. (past the hour)			H3548					
B15 to B8	B7 to B0														
Minutes (0 to 59)	Seconds (0 to 59)	: 35 min. 48 sec. (past the hour)													
		H3548													
SD4	Error information categories	Error information category code	<ul style="list-style-type: none"> Error information is stored in Error common information (SD5 to SD15) and Error individual information (SD16 to SD26). This register stores a category code indicating an error information type. <table border="1"> <tr> <td>B15 to B8</td> <td>B7 to B0</td> <td></td> </tr> <tr> <td>Individual information category codes</td> <td>Common information category codes</td> <td></td> </tr> </table> <ul style="list-style-type: none"> The common information category codes store the following codes: <ol style="list-style-type: none"> 0 : No error 1 : Module No. (Slot No./CPU No./Base No.) * 1 2 : File name/Drive name 3 : Time (value set) 4 : Program error location 5 : Reason(s) for system switching (for the Q4AR and Redundant CPU) 6 : Reason(s) for tracking size excess error (for the Redundant CPU) 7 : Base No./power supply No. (Universal model QCPU: This applies to modules with a serial number (first five digits) of "10042" or later.) 8 : Tracking transmission data classification (for the Redundant CPU) <ul style="list-style-type: none"> * 1: For the multiple CPU system using the Basic model QCPU, High Performance model QCPU, Process CPU, and Universal model QCPU, the module No. or CPU No. is stored according to an error. (For details, refer to each error code.) CPU No.1: 1, CPU No.2: 2, CPU No.3: 3, CPU No.4: 4 The individual information category codes store the following codes: <ol style="list-style-type: none"> 0 : No error 1 : (Empty) 2 : File name/Drive name 3 : Time (value actually measured) 4 : Program error location 5 : Parameter number 6 : Annunciator (F)number 7 : CHK instruction malfunction number (except for Basic model QCPU and Universal model QCPU) 8 : Reason(s) for system switching failure (for the Redundant CPU) 12 : File diagnostic information (for the Universal model QCPU) 13 : Parameter No./CPU No. (for the Universal model QCPU) 	B15 to B8	B7 to B0		Individual information category codes	Common information category codes		S (Error)	New	○ Rem			
B15 to B8	B7 to B0														
Individual information category codes	Common information category codes														

Special Register List (Continued)

Number	Name	Meaning	Explanation	Set by (When set)	Corresponding ACPU D9 <input type="checkbox"/> <input type="checkbox"/> <input type="checkbox"/>	Corresponding CPU																																								
SD5 SD6 SD7 SD8 SD9 SD10 SD11 SD12 SD13 SD14 SD15	Error common information	Error common information	<ul style="list-style-type: none"> This register stores common information corresponding to the error code stored in SD0. The following five types of information are stored here. The error common information type can be determined by "common information category code" stored in SD4. (Values stored in "common information category code" correspond to the following ① to ⑤.) <p>① Module No.</p> <table border="1"> <thead> <tr> <th>Number</th> <th>Meaning</th> </tr> </thead> <tbody> <tr> <td>SD5</td> <td>Slot No./CPU No.* 1* 2* 3* 4</td> </tr> <tr> <td>SD6</td> <td>I/O No.*5</td> </tr> <tr> <td>SD7</td> <td rowspan="9">(Empty)</td> </tr> <tr> <td>SD8</td> </tr> <tr> <td>SD9</td> </tr> <tr> <td>SD10</td> </tr> <tr> <td>SD11</td> </tr> <tr> <td>SD12</td> </tr> <tr> <td>SD13</td> </tr> <tr> <td>SD14</td> </tr> <tr> <td>SD15</td> </tr> </tbody> </table> <ul style="list-style-type: none"> * 1: For the multiple CPU system using the Basic model QCPU, High Performance model QCPU, Process CPU, and Universal model QCPU, the slot No. or CPU No. is stored according to an error. (For details, refer to each error code.) CPU No.1: 1, CPU No.2: 2, CPU No.3: 3, CPU No.4: 4 * 2: If a fuse has been blown or an I/O module verify error occurs in a module on the MELSECNET/H remote I/O station, the network No. is stored in the upper 8 bits and the station No. is stored in the lower 8 bits. To determine a fuse-blown module or a module where an I/O module verify error occurs, check the I/O No. * 3: If an instruction is executed from the Basic model QCPU to a module mounted on the slot where no module should be mounted, "255" is stored in SD5. * 4: Definitions of base No. and slot No. <Base No.> This number indicates a base unit on which the CPU module is mounted. <table border="1"> <thead> <tr> <th>Base No.</th> <th>Definition</th> </tr> </thead> <tbody> <tr> <td>0</td> <td>Indicates the main base unit mounted with the CPU module.</td> </tr> <tr> <td>1 to 7</td> <td>Indicates the extension base unit. The stage number setting made by the stage number setting connector on the extension base unit is the base No. When stage number setting is extension 1: Base No. = 1 when stage number setting is extension 7: Base No. = 7</td> </tr> </tbody> </table> <p><Slot No.> This number is used to identify the slot of each base unit and a module mounted on the slot.</p> <ul style="list-style-type: none"> The "0" I/O slot (slot on the right of the CPU slot) on the main base unit is defined as "Slot No. = 0". The slot Nos. are assigned in sequence numbers in order of the main base unit and then the first extension base unit to 7th extension base unit. When the number of slots on base units has been set in the I/O assignment tab of the PLC Parameter dialog box, the slot Nos. are assigned by the number of set slots. <ul style="list-style-type: none"> * 5: If FFFFH is stored in SD6 (I/O No.), this indicates that the I/O No. cannot be identified due to an error such as overlap of an I/O No. in the I/O assignment tab of the PLC Parameter dialog box. In this case, identify the error location using SD5. <p>② File name/Drive name</p> <table border="1"> <thead> <tr> <th>Number</th> <th>Meaning</th> </tr> </thead> <tbody> <tr> <td>SD5</td> <td>Drive</td> </tr> <tr> <td>SD6</td> <td rowspan="5">File name (ASCII code: 8 characters)</td> </tr> <tr> <td>SD7</td> </tr> <tr> <td>SD8</td> </tr> <tr> <td>SD9</td> </tr> <tr> <td>SD10</td> <td>Extension*6 2EH(.)</td> </tr> <tr> <td>SD11</td> <td>(ASCII code: 3 characters)</td> </tr> <tr> <td>SD12</td> <td rowspan="4">(Empty)</td> </tr> <tr> <td>SD13</td> </tr> <tr> <td>SD14</td> </tr> <tr> <td>SD15</td> </tr> </tbody> </table> <p>(Example) File name= ABCDEFGH. IJK B15 to B8 B7 to B0 42H(B) 41H(A) 44H(D) 43H(C) 46H(F) 45H(E) 48H(H) 47H(G) 49H(I) 2EH(.) 4BH(K) 4AH(J)</p>	Number	Meaning	SD5	Slot No./CPU No.* 1* 2* 3* 4	SD6	I/O No.*5	SD7	(Empty)	SD8	SD9	SD10	SD11	SD12	SD13	SD14	SD15	Base No.	Definition	0	Indicates the main base unit mounted with the CPU module.	1 to 7	Indicates the extension base unit. The stage number setting made by the stage number setting connector on the extension base unit is the base No. When stage number setting is extension 1: Base No. = 1 when stage number setting is extension 7: Base No. = 7	Number	Meaning	SD5	Drive	SD6	File name (ASCII code: 8 characters)	SD7	SD8	SD9	SD10	Extension*6 2EH(.)	SD11	(ASCII code: 3 characters)	SD12	(Empty)	SD13	SD14	SD15	S (Error)	New	○ Rem
Number			Meaning																																											
SD5			Slot No./CPU No.* 1* 2* 3* 4																																											
SD6			I/O No.*5																																											
SD7			(Empty)																																											
SD8																																														
SD9																																														
SD10																																														
SD11																																														
SD12																																														
SD13																																														
SD14																																														
SD15																																														
Base No.			Definition																																											
0			Indicates the main base unit mounted with the CPU module.																																											
1 to 7	Indicates the extension base unit. The stage number setting made by the stage number setting connector on the extension base unit is the base No. When stage number setting is extension 1: Base No. = 1 when stage number setting is extension 7: Base No. = 7																																													
Number	Meaning																																													
SD5	Drive																																													
SD6	File name (ASCII code: 8 characters)																																													
SD7																																														
SD8																																														
SD9																																														
SD10		Extension*6 2EH(.)																																												
SD11	(ASCII code: 3 characters)																																													
SD12	(Empty)																																													
SD13																																														
SD14																																														
SD15																																														

*6: The extension names are listed below.

SDn	SDn+1		Extension	File type
	Higher 8 bits	Lower 8 bits		
51H	50H	41H	QPA	Parameters
51H	50H	47H	QPG	• Sequence program • SFC program
51H	43H	44H	QCD	Device comment
51H	44H	49H	QDI	Initial device value
51H	44H	52H	QDR	File register
51H	44H	53H	QDS	Simulation data (for the QnACPU)
51H	44H	4CH	QDL	Local device (except the Basic model QCPU)
51H	54H	44H	QTD	Sampling trace data (except the Basic model QCPU)
51H	54H	4CH	QTL	Status latch data (for the QnACPU)
51H	54H	50H	QTP	Program trace data (for the QnACPU)
51H	54H	52H	QTR	SFC trace file (for the QnACPU)
51H	46H	44H	QFD	Error history data (except the Basic model QCPU and Universal model QCPU)
51H	53H	54H	QST	SP.DEVST/S.DEVLD instruction file (for the Universal model QCPU only)

Special Register List (Continued)

Number	Name	Meaning	Explanation	Set by (When set)	Corresponding ACPU D9 <input type="checkbox"/> <input type="checkbox"/> <input type="checkbox"/>	Corresponding CPU <input type="radio"/>																																																																																																												
SD16	Error individual information	Error individual information	<p>• This register stores individual information corresponding to the error code stored in SD0.</p> <p>• The following six types of information are stored here.</p> <p>• The error individual information type can be determined by "individual information category code" stored in SD4. (Values stored in "individual information category code" correspond to the following 1) to 7-.)</p> <p>① (Empty)</p> <p>② File name/Drive name</p> <table border="1" style="margin-left: 20px;"> <thead> <tr> <th>Number</th> <th>Meaning</th> </tr> </thead> <tbody> <tr> <td>SD16</td> <td>Drive</td> </tr> <tr> <td>SD17</td> <td rowspan="6">File name (ASCII code: 8 characters)</td> </tr> <tr> <td>SD18</td> </tr> <tr> <td>SD19</td> </tr> <tr> <td>SD20</td> </tr> <tr> <td>SD21</td> <td>Extension *1 2EH(.)</td> </tr> <tr> <td>SD22</td> <td>(ASCII code: 3 characters)</td> </tr> <tr> <td>SD23</td> <td rowspan="4">(Empty)</td> </tr> <tr> <td>SD24</td> </tr> <tr> <td>SD25</td> </tr> <tr> <td>SD26</td> </tr> </tbody> </table> <p>(Example) File name= ABCDEFGH. IJK B15 to B8 B7 to B0 42H(B) 41H(A) 44H(D) 43H(C) 46H(F) 45H(E) 48H(H) 47H(G) 49H(I) 2EH(.) 4BH(K) 4AH(J)</p> <p>③ Time (value actually measured)</p> <table border="1" style="margin-left: 20px;"> <thead> <tr> <th>Number</th> <th>Meaning</th> </tr> </thead> <tbody> <tr> <td>SD16</td> <td>Time : 1 μs units (0 to 999 μs)</td> </tr> <tr> <td>SD17</td> <td>Time : 1 ms units (0 to 65535 ms)</td> </tr> <tr> <td>SD18</td> <td rowspan="8">(Empty)</td> </tr> <tr> <td>SD19</td> </tr> <tr> <td>SD20</td> </tr> <tr> <td>SD21</td> </tr> <tr> <td>SD22</td> </tr> <tr> <td>SD23</td> </tr> <tr> <td>SD24</td> </tr> <tr> <td>SD25</td> </tr> </tbody> </table> <p>④ Program error location</p> <table border="1" style="margin-left: 20px;"> <thead> <tr> <th>Number</th> <th>Meaning</th> </tr> </thead> <tbody> <tr> <td>SD16</td> <td rowspan="4">File name (ASCII code: 8 characters)</td> </tr> <tr> <td>SD17</td> </tr> <tr> <td>SD18</td> </tr> <tr> <td>SD19</td> </tr> <tr> <td>SD20</td> <td>Extension *1 2EH(.)</td> </tr> <tr> <td>SD21</td> <td>(ASCII code: 3 characters)</td> </tr> <tr> <td>SD22</td> <td>Pattern*2</td> </tr> <tr> <td>SD23</td> <td>Block No.</td> </tr> <tr> <td>SD24</td> <td>Step No./transition No.</td> </tr> <tr> <td>SD25</td> <td>Sequence step No. (L)</td> </tr> <tr> <td>SD26</td> <td>Sequence step No. (H)</td> </tr> </tbody> </table> <p>* 2: The description of the bit pattern is as follows:</p> <table border="1" style="margin-left: 20px;"> <tr> <td>15</td><td>14</td><td>to</td><td>4</td><td>3</td><td>2</td><td>1</td><td>0</td> </tr> <tr> <td colspan="8" style="text-align: right;">← (Bit number)</td> </tr> <tr> <td>0</td><td>0</td><td>to</td><td>0</td><td>0</td><td>*</td><td>*</td><td>*</td> </tr> </table> <p>(Not used)</p> <ul style="list-style-type: none"> — SFC block designation present (1)/absent (0) — SFC step designation present (1)/absent (0) — SFC transition designation present (1)/absent (0) <p>⑤ Parameter number</p> <table border="1" style="margin-left: 20px;"> <thead> <tr> <th>Number</th> <th>Meaning</th> </tr> </thead> <tbody> <tr> <td>SD16</td> <td>Parameter No.*3</td> </tr> <tr> <td>SD17</td> <td rowspan="10">(Empty)</td> </tr> <tr> <td>SD18</td> </tr> <tr> <td>SD19</td> </tr> <tr> <td>SD20</td> </tr> <tr> <td>SD21</td> </tr> <tr> <td>SD22</td> </tr> <tr> <td>SD23</td> </tr> <tr> <td>SD24</td> </tr> <tr> <td>SD25</td> </tr> <tr> <td>SD26</td> </tr> </tbody> </table> <p>⑥ Annunciator number</p> <table border="1" style="margin-left: 20px;"> <thead> <tr> <th>Number</th> <th>Meaning</th> </tr> </thead> <tbody> <tr> <td>SD16</td> <td>No.</td> </tr> <tr> <td>SD17</td> <td rowspan="10">(Empty)</td> </tr> <tr> <td>SD18</td> </tr> <tr> <td>SD19</td> </tr> <tr> <td>SD20</td> </tr> <tr> <td>SD21</td> </tr> <tr> <td>SD22</td> </tr> <tr> <td>SD23</td> </tr> <tr> <td>SD24</td> </tr> <tr> <td>SD25</td> </tr> <tr> <td>SD26</td> </tr> </tbody> </table> <p>⑦ CHK instruction malfunction number</p> <p>* 3: For details of the parameter numbers, refer to the User's manual (Function Explanation, Program Fundamentals) for the CPU module used.</p>	Number	Meaning	SD16	Drive	SD17	File name (ASCII code: 8 characters)	SD18	SD19	SD20	SD21	Extension *1 2EH(.)	SD22	(ASCII code: 3 characters)	SD23	(Empty)	SD24	SD25	SD26	Number	Meaning	SD16	Time : 1 μs units (0 to 999 μs)	SD17	Time : 1 ms units (0 to 65535 ms)	SD18	(Empty)	SD19	SD20	SD21	SD22	SD23	SD24	SD25	Number	Meaning	SD16	File name (ASCII code: 8 characters)	SD17	SD18	SD19	SD20	Extension *1 2EH(.)	SD21	(ASCII code: 3 characters)	SD22	Pattern*2	SD23	Block No.	SD24	Step No./transition No.	SD25	Sequence step No. (L)	SD26	Sequence step No. (H)	15	14	to	4	3	2	1	0	← (Bit number)								0	0	to	0	0	*	*	*	Number	Meaning	SD16	Parameter No.*3	SD17	(Empty)	SD18	SD19	SD20	SD21	SD22	SD23	SD24	SD25	SD26	Number	Meaning	SD16	No.	SD17	(Empty)	SD18	SD19	SD20	SD21	SD22	SD23	SD24	SD25	SD26	S (Error)	New	○ Rem
Number				Meaning																																																																																																														
SD16				Drive																																																																																																														
SD17				File name (ASCII code: 8 characters)																																																																																																														
SD18																																																																																																																		
SD19																																																																																																																		
SD20																																																																																																																		
SD21					Extension *1 2EH(.)																																																																																																													
SD22					(ASCII code: 3 characters)																																																																																																													
SD23				(Empty)																																																																																																														
SD24																																																																																																																		
SD25																																																																																																																		
SD26																																																																																																																		
Number				Meaning																																																																																																														
SD16				Time : 1 μs units (0 to 999 μs)																																																																																																														
SD17				Time : 1 ms units (0 to 65535 ms)																																																																																																														
SD18	(Empty)																																																																																																																	
SD19																																																																																																																		
SD20																																																																																																																		
SD21																																																																																																																		
SD22																																																																																																																		
SD23																																																																																																																		
SD24																																																																																																																		
SD25																																																																																																																		
Number	Meaning																																																																																																																	
SD16	File name (ASCII code: 8 characters)																																																																																																																	
SD17																																																																																																																		
SD18																																																																																																																		
SD19																																																																																																																		
SD20	Extension *1 2EH(.)																																																																																																																	
SD21	(ASCII code: 3 characters)																																																																																																																	
SD22	Pattern*2																																																																																																																	
SD23	Block No.																																																																																																																	
SD24	Step No./transition No.																																																																																																																	
SD25	Sequence step No. (L)																																																																																																																	
SD26	Sequence step No. (H)																																																																																																																	
15	14	to	4	3	2	1	0																																																																																																											
← (Bit number)																																																																																																																		
0	0	to	0	0	*	*	*																																																																																																											
Number	Meaning																																																																																																																	
SD16	Parameter No.*3																																																																																																																	
SD17	(Empty)																																																																																																																	
SD18																																																																																																																		
SD19																																																																																																																		
SD20																																																																																																																		
SD21																																																																																																																		
SD22																																																																																																																		
SD23																																																																																																																		
SD24																																																																																																																		
SD25																																																																																																																		
SD26																																																																																																																		
Number	Meaning																																																																																																																	
SD16	No.																																																																																																																	
SD17	(Empty)																																																																																																																	
SD18																																																																																																																		
SD19																																																																																																																		
SD20																																																																																																																		
SD21																																																																																																																		
SD22																																																																																																																		
SD23																																																																																																																		
SD24																																																																																																																		
SD25																																																																																																																		
SD26																																																																																																																		
SD17																																																																																																																		
SD18																																																																																																																		
SD19																																																																																																																		
SD20																																																																																																																		
SD21																																																																																																																		
SD22																																																																																																																		
SD23																																																																																																																		
SD24																																																																																																																		
SD25																																																																																																																		
SD26																																																																																																																		

*1: For extensions, refer to *6.

Special Register List (Continued)

Number	Name	Meaning	Explanation	Set by (When set)	Corresponding ACPU D9□□□	Corresponding CPU
SD50	Error reset	Error code where the error reset is performed	• This register stores the error code where the error reset is performed.	U	New	○ Rem
SD53	AC/DC DOWN detection	Number of times for AC/DC DOWN detection	• A value stored in this register is incremented by 1 whenever the input voltage falls to or below 85% (AC power)/65% (DC power) of the rating during operation of the CPU module. The value is stored in BIN. • The counter repeats increment and decrement of the value; 0→32767→32768→0.	S (Error)	D9005	○ Rem
SD60	Number of module with blown fuse	Number of module with blown fuse	• This register stores the lowest I/O number of the module with a blown fuse.	S (Error)	D9000	○ Rem
SD61	I/O module verify error number	I/O module verify error module number	• This register stores the lowest I/O number of the module where the I/O module verify error has occurred.	S (Error)	D9002	
SD105	CH1 transmission speed setting (RS-232)	Stores a transmission speed set in GX Developer.	96 : 9600bps, 192 : 19.2kbps, 384 : 38.4kbps 576 : 57.6kbps, 1152 : 115.2kbps The data of the RS-232 connection is used for any other connection. (When an external device is not connected, the default is 1152).	S	New	Qn(H) QnPH QnPRH QnU * 1 Rem

*1: This applies to Universal model QCPUs except for the Built-in Ethernet port QCPU.

(2) System information
Special Register List

Number	Name	Meaning	Explanation	Set by (When set)	Corresponding ACPU D9□□□	Corresponding CPU						
SD200	Status of switch	Status of CPU switch	<p>• This register stores the status of the remote I/O module switch in the following bit pattern.</p> <p>① Remote I/O module switch status Always 1: STOP</p>	S (Always)	New	Rem						
			<p>• This register stores the status of the CPU module switches in the following bit pattern.</p> <table border="1"> <tr> <td>①: CPU switch status</td> <td>0: RUN 1: STOP 2: L.CLR</td> </tr> <tr> <td>②: Memory card switch</td> <td>Always OFF</td> </tr> <tr> <td>③: DIP switch</td> <td>B8 through B12 correspond to SW1 through SW5 of system setting switch 1. 0: OFF, 1: ON BD through BF are empty.</td> </tr> </table>	①: CPU switch status	0: RUN 1: STOP 2: L.CLR	②: Memory card switch	Always OFF	③: DIP switch	B8 through B12 correspond to SW1 through SW5 of system setting switch 1. 0: OFF, 1: ON BD through BF are empty.	S (Every END processing)	New	Qn(H) QnPH QnPRH
			①: CPU switch status	0: RUN 1: STOP 2: L.CLR								
			②: Memory card switch	Always OFF								
			③: DIP switch	B8 through B12 correspond to SW1 through SW5 of system setting switch 1. 0: OFF, 1: ON BD through BF are empty.								
<p>• This register stores the status of the CPU module switches in the following bit pattern.</p> <table border="1"> <tr> <td>①: CPU switch status</td> <td>0: RUN 1: STOP</td> </tr> <tr> <td>②: Memory card switch</td> <td>Always OFF</td> </tr> </table>	①: CPU switch status	0: RUN 1: STOP	②: Memory card switch	Always OFF	S (Every END processing)	New	Q00J/Q00/Q01					
①: CPU switch status	0: RUN 1: STOP											
②: Memory card switch	Always OFF											
<p>• This register stores the status of the CPU module switches in the following bit pattern.</p> <table border="1"> <tr> <td>①: CPU switch status</td> <td>0: RUN 1: STOP</td> </tr> <tr> <td>②: Memory card switch</td> <td>Always OFF</td> </tr> </table>	①: CPU switch status	0: RUN 1: STOP	②: Memory card switch	Always OFF	S (when RUN/ STOP/ RESET switch changed)	New	QnU					
①: CPU switch status	0: RUN 1: STOP											
②: Memory card switch	Always OFF											
<p>• This register stores the status of the CPU module switches in the following bit pattern.</p> <table border="1"> <tr> <td>①: CPU key State of switch</td> <td>0: RUN 1: STOP 2: L.CLR</td> </tr> <tr> <td>②: Memory card switch</td> <td>B4: card A, B5: card B, 0: OFF, 1: ON</td> </tr> <tr> <td>③: DIP switch</td> <td>B8 through B12 correspond to SW1 through SW5 of system setting switch 1. B14 and B15 correspond to SW1 and SW2 of system setting switch 2. 0: OFF, 1: ON</td> </tr> </table>	①: CPU key State of switch	0: RUN 1: STOP 2: L.CLR	②: Memory card switch	B4: card A, B5: card B, 0: OFF, 1: ON	③: DIP switch	B8 through B12 correspond to SW1 through SW5 of system setting switch 1. B14 and B15 correspond to SW1 and SW2 of system setting switch 2. 0: OFF, 1: ON	S (Every END processing)	New	QnA			
①: CPU key State of switch	0: RUN 1: STOP 2: L.CLR											
②: Memory card switch	B4: card A, B5: card B, 0: OFF, 1: ON											
③: DIP switch	B8 through B12 correspond to SW1 through SW5 of system setting switch 1. B14 and B15 correspond to SW1 and SW2 of system setting switch 2. 0: OFF, 1: ON											

Special Register List (Continued)

Number	Name	Meaning	Explanation	Set by (When set)	Corresponding ACPU D9□□□	Corresponding CPU																
SD203	Operating status of CPU	Operating status of CPU	<ul style="list-style-type: none"> This register stores the operating status of the remote I/O module in the following bit pattern. <p>① Operating status of remote I/O module Always 2: STOP</p>	S (Always)	New	Remote																
			<ul style="list-style-type: none"> This register stores the operating status of the CPU module in the following bit pattern. <p>①: Operating state of CPU 0 :RUN 1 :STEP-RUN (For the QnACPU only) 2 :STOP 3 :PAUSE</p> <p>②: STOP/PAUSE cause Note: Priority is earliest first (For Universal model QCPU, however, the latest cause for operation status change is stored.) 0 :RUN/STOP switch ("RUN/STOP/RESET switch" for Basic model QCPU and Universal model QCPU) 1 :Remote contact 2 :Remote operation from GX Developer or serial communication modules 3 :Internal program instruction 4 :Error</p>	S (Every END processing)	D9015 format change	○																
SD206	Device test execution type	0: No test being executed 1: During X device test 2: During Y device test 3: During X/Y device test	<ul style="list-style-type: none"> A value is stored in this register when inputs/outputs are forcibly registered by GX Developer. 	S (Request)	New	Rem																
SD210	Clock data	Clock data (year, month)	<ul style="list-style-type: none"> This register stores the year (last two digits) and month in BCD as shown below. 		D9025																	
SD211	Clock data	Clock data (day, hour)	<ul style="list-style-type: none"> This register stores the day and hour in BCD as shown below. 	S (Request)/U	D9026	○ Rem																
SD212	Clock data	Clock data (minute, second)	<ul style="list-style-type: none"> This register stores the minute and the second in BCD as shown below. 		D9027																	
SD213	Clock data	Clock data (higher digits of year, day of week)	<ul style="list-style-type: none"> This register stores the year (first two digits) and day of week in BCD as shown below. <p>First two digits of year (19 or 20)</p> <table border="1"> <thead> <tr> <th>Day of week</th> <th></th> </tr> </thead> <tbody> <tr><td>0</td><td>Sunday</td></tr> <tr><td>1</td><td>Monday</td></tr> <tr><td>2</td><td>Tuesday</td></tr> <tr><td>3</td><td>Wednesday</td></tr> <tr><td>4</td><td>Thursday</td></tr> <tr><td>5</td><td>Friday</td></tr> <tr><td>6</td><td>Saturday</td></tr> </tbody> </table>	Day of week		0	Sunday	1	Monday	2	Tuesday	3	Wednesday	4	Thursday	5	Friday	6	Saturday	S (Request)/U	D9028	QCPU Rem
Day of week																						
0	Sunday																					
1	Monday																					
2	Tuesday																					
3	Wednesday																					
4	Thursday																					
5	Friday																					
6	Saturday																					

Special Register List (Continued)

Number	Name	Meaning	Explanation	Set by (When set)	Corresponding ACPU D9	Corresponding CPU
SD240	Base mode	0: Automatic mode 1: Detail mode	• This register stores the base mode.	S (Initial)	New	Qn(H) QnPH QnPRH Rem
SD241	Extension stage number	0: Main base only 1 to 7: Number of extension base units	• This register stores the number of extension base units installed.	S (Initial)	New	
SD242	A/Q base differentiation	Base type differentiation 0: QA * * B is installed (A mode) 1: Q * * B is installed (Q mode)		S (Initial)	New	
	Installed Q base presence/absence	Base type differentiation 0: Base not installed 1: Q**B is installed		S (Initial)	New	Q00J/Q00/Q01
	Installed Q Base presence/absence	Base type differentiation 0: Base not installed 1: Q**B is installed		S (Initial)	New	QnU
SD243	No. of base slots	No. of base slots		S (Initial)	New	Qn(H) QnPH QnPRH QnU Rem
SD244			• The number of slots used is stored in the area corresponding to each base unit as shown above.			
SD250	Loaded maximum I/O	Loaded maximum I/O No.	• When SM250 is turned on, the first two digits of the number, which are the last I/O number of the mounted modules plus 1, are stored in binary format.	S (Request END)	New	Qn(H) QnPH QnPRH Rem
			• The first two digits of the number, which are the last I/O number of the mounted modules plus 1, are stored in binary format.	S (Initial)	New	Q00J/ Q00/Q01 QnU Rem

Special Register List (Continued)

Number	Name	Meaning	Explanation	Set by (When set)	Corresponding ACPU D9 <input type="checkbox"/> <input type="checkbox"/> <input type="checkbox"/>	Corresponding CPU
SD280	CC-Link error	Error detection status	<p>① When Xn0 of a mounted CC-Link module turns on, the corresponding bit is set to 1 (on).</p> <p>② When either Xn1 or XnF of a mounted CC-Link module turns off, the corresponding bit is set to 1 (on).</p> <p>③ When a mounted CC-Link module is not able to communicate with the CPU module, the corresponding bit is set to 1 (on).</p> <p>The above modules are numbered in order of the start I/O numbers. (However, the one where no start I/O number is set in parameter is not counted.)</p>	S (Error)	New	Qn(H) QnPH QnPRH Rem
			<p>① When Xn0 of a mounted CC-Link module turns on, the corresponding bit is set to 1 (on).</p> <p>② When either Xn1 or XnF of a mounted CC-Link module turns off, the corresponding bit is set to 1 (on).</p> <p>③ When a mounted CC-Link module is not able to communicate with the CPU module, the corresponding bit is set to 1 (on).</p>			QnA
SD290	Device assignment (same as parameter contents)	Number of points assigned for X	• Stores the number of points currently set for X devices	S (Initial)	New	○ Rem
SD291		Number of points assigned for Y	• Stores the number of points currently set for Y devices			
SD292		Number of points assigned for M	• Stores the number of points currently set for M devices			
SD294		Number of points assigned for B	• Stores the number of points currently set for B devices			
SD296		Number of points assigned for SB	• Stores the number of points currently set for SB devices			
SD302		Number of points assigned for D	• Stores the number of points currently set for D devices			
SD303		Number of points assigned for W	• Stores the number of points currently set for W devices			
SD304	Number of points assigned for SW	• Stores the number of points currently set for SW devices				
SD315	Time reserved for communication processing	Time reserved for communication processing	<p>• This register specifies the amount of processing time for communication with GX Developer or other devices.</p> <p>• The greater the value specified is, the shorter the response time for communication with another device (such as GX Developer or serial communication module) is. However, scan time will increase by the specified time.</p> <p>• Setting range: 1 to 100ms</p> <p>• A setting outside the above range is regarded as no setting.</p>	U	New	Q00J/ Q00/Q01 Qn(H) QnPH QnPRH Rem

Special Register List (Continued)

Number	Name	Meaning	Explanation	Set by (When set)	Corresponding ACPU D9□□□	Corresponding CPU
SD340	Ethernet information	No. of modules mounted	• Indicates the number of mounted Ethernet modules.	S (Initial)	New	QCPU Rem
SD341		I/O No.	• Indicates I/O No. of mounted Ethernet module.			
SD342		Network No.	• Indicates network No. of mounted Ethernet module.			
SD343		Group No.	• Indicates group No. of mounted Ethernet module.			
SD344		Station No.	• Indicates station No. of mounted Ethernet module.			
SD345 to SD346		Empty	• Empty (For the QCPU, the IP address of the 1st Ethernet module is stored in the buffer memory.)			Qn(H) QnPH QnPRH QnU Rem
SD347		Empty	• Empty (For the QCPU, an error code of the 1st Ethernet module is read with the ERRRD instruction.)			
SD348 to SD354	Ethernet information	Information from 2nd module	• Data configuration is the same as that of the 1st module.	S (Initial)	New	Qn(H) QnPH QnPRH QnU ^{*1} Rem
SD355 to SD361		Information from 3rd module	• Data configuration is the same as that of the 1st module.			
SD362 to SD368		Information from 4th module	• Data configuration is the same as that of the 1st module.			

*1: This applies to Universal model QCPUs except for the Q02UCPU.

(3) Scan information

Special Register List

Number	Name	Meaning	Explanation	Set by (When set)	Corresponding ACPU D9□□□	Corresponding CPU
SD550	Service interval measurement module	Module No.	• Sets I/O No. for module that measures service interval	U	New	QnA Qn(H) QnPH QnPRH Rem
SD551	Service interval time	Module service interval (ms value)	• This register stores the service interval of a module specified by SD550 when SM551 is turned on. (The time is measured in increments of 100µs.) SD551: Stores a ms value (storage range: 0 to 65535) SD552: Stores a µs value (storage range: 0 to 900)	S (Request)	New	
SD552		Module service interval (µs value)				

(4) Fuse blown module
Special Register List

Number	Name	Meaning	Explanation	Set by (When set)	Corresponding ACPU D9□□□	Corresponding CPU																																
SD1300	Fuse blown module	Bit pattern in units of 16 points, indicating the modules whose fuses have blown 0: No blown fuse 1: Blown fuse	<ul style="list-style-type: none"> The number of an output module whose fuse has blown is stored in the following bit pattern (in units of 16 points). (If the module numbers are set by parameter, the parameter-set numbers are stored.) The status of the blown fuse of an output module on a remote station is also detected. <div style="text-align: center;"> <table border="1" style="margin: auto;"> <tr> <td>15</td><td>14</td><td>13</td><td>12</td><td>11</td><td>10</td><td>9</td><td>8</td><td>7</td><td>6</td><td>5</td><td>4</td><td>3</td><td>2</td><td>1</td><td>0</td> </tr> <tr> <td>0</td><td>0</td><td>0</td><td>1 (YCD)</td><td>0</td><td>0</td><td>0</td><td>1 (Y8D)</td><td>0</td><td>0</td><td>0</td><td>0</td><td>0</td><td>0</td><td>0</td><td>0</td> </tr> </table> </div>	15	14	13	12	11	10	9	8	7	6	5	4	3	2	1	0	0	0	0	1 (YCD)	0	0	0	1 (Y8D)	0	0	0	0	0	0	0	0	S (Error)	D9100	QnA Qn(H) QnPH QnPRH QnU Rem
15				14	13	12	11	10	9	8	7	6	5	4	3	2	1	0																				
0				0	0	1 (YCD)	0	0	0	1 (Y8D)	0	0	0	0	0	0	0	0																				
SD1301				D9101																																		
SD1302				D9102																																		
SD1303				D9103																																		
SD1304				D9104																																		
SD1305				D9105																																		
SD1306				D9106																																		
SD1307				D9107																																		
SD1308				New																																		
SD1309 to SD1330	New																																					
SD1331			<ul style="list-style-type: none"> For a module whose number of output points exceeds 16 points, all bits corresponding to output module numbers within the number of output points occupied by the module (in units of 16 points) turn on. (Example) When a 64-point module is mounted on the slot 0, b0 to b3 turn on when the fuse has blown. The module No. is not cleared even when the output module goes back to normal. The number is cleared by clearing the error. <div style="text-align: center;"> <table border="1" style="margin: auto;"> <tr> <td>15</td><td>14</td><td>13</td><td>12</td><td>11</td><td>10</td><td>9</td><td>8</td><td>7</td><td>6</td><td>5</td><td>4</td><td>3</td><td>2</td><td>1</td><td>0</td> </tr> <tr> <td>0</td><td>0</td><td>0</td><td>0</td><td>0</td><td>0</td><td>0</td><td>0</td><td>0</td><td>0</td><td>0</td><td>0</td><td>0</td><td>0</td><td>0</td><td>0</td> </tr> </table> <p style="text-align: center;">↑ Indicates a blown fuse</p> </div>	15	14	13	12	11	10	9	8	7	6	5	4	3	2	1	0	0	0	0	0	0	0	0	0	0	0	0	0	0	0	0	0		New	
15	14	13	12	11	10	9	8	7	6	5	4	3	2	1	0																							
0	0	0	0	0	0	0	0	0	0	0	0	0	0	0	0																							

(5) I/O module verification
Special Register List

Number	Name	Meaning	Explanation	Set by (When set)	Corresponding ACPU D9□□□	Corresponding CPU																																
SD1400	I/O module verify error	Bit pattern, in units of 16 points, indicating the module with an I/O module verify error 0: No error 1: Error	<ul style="list-style-type: none"> If the status of the I/O module changes from that obtained at power-on, the module No. is stored in the following bit pattern (in units of 16 points). (If the I/O numbers are set by parameter, the parameter-set numbers are stored.) I/O module information is also detected. <div style="text-align: center;"> <table border="1" style="margin: auto;"> <tr> <td>15</td><td>14</td><td>13</td><td>12</td><td>11</td><td>10</td><td>9</td><td>8</td><td>7</td><td>6</td><td>5</td><td>4</td><td>3</td><td>2</td><td>1</td><td>0</td> </tr> <tr> <td>0</td><td>0</td><td>0</td><td>0</td><td>0</td><td>0</td><td>0</td><td>0</td><td>0</td><td>0</td><td>0</td><td>0</td><td>0</td><td>0</td><td>0</td><td>1 (Y₈)</td> </tr> </table> </div>	15	14	13	12	11	10	9	8	7	6	5	4	3	2	1	0	0	0	0	0	0	0	0	0	0	0	0	0	0	0	0	1 (Y ₈)	S (Error)	D9116	QnA Qn(H) QnPH QnPRH QnU Rem
15				14	13	12	11	10	9	8	7	6	5	4	3	2	1	0																				
0				0	0	0	0	0	0	0	0	0	0	0	0	0	0	1 (Y ₈)																				
SD1401				D9117																																		
SD1402				D9118																																		
SD1403				D9119																																		
SD1404				D9120																																		
SD1405				D9121																																		
SD1406				D9122																																		
SD1407				D9123																																		
SD1408				New																																		
SD1409 to SD1430	New																																					
SD1431			<ul style="list-style-type: none"> For a module whose number of I/O points exceeds 16 points, all bits corresponding to I/O module numbers within the number of I/O points occupied by the module (in units of 16 points) turn on. (Example) When a 64-point module is mounted on the slot 0, b0 to b3 turn on when an error is detected. The module No. is not cleared even when the I/O module goes back to normal. The number is cleared by clearing the error. <div style="text-align: center;"> <table border="1" style="margin: auto;"> <tr> <td>15</td><td>14</td><td>13</td><td>12</td><td>11</td><td>10</td><td>9</td><td>8</td><td>7</td><td>6</td><td>5</td><td>4</td><td>3</td><td>2</td><td>1</td><td>0</td> </tr> <tr> <td>0</td><td>0</td><td>0</td><td>0</td><td>0</td><td>0</td><td>0</td><td>0</td><td>0</td><td>0</td><td>0</td><td>0</td><td>0</td><td>0</td><td>0</td><td>0</td> </tr> </table> <p style="text-align: center;">↑ Indicates an I/O module verification error</p> </div>	15	14	13	12	11	10	9	8	7	6	5	4	3	2	1	0	0	0	0	0	0	0	0	0	0	0	0	0	0	0	0	0		New	
15	14	13	12	11	10	9	8	7	6	5	4	3	2	1	0																							
0	0	0	0	0	0	0	0	0	0	0	0	0	0	0	0																							

(6) Redundant power supply module information

The special register (SD1780 to SD1789) is valid only for redundant power supply systems. All bits are set to "0" for single power supply systems.

Special Register List

Number	Name	Meaning	Explanation	Set by (When set)	Corresponding ACPU D9 [] [] [] []	Corresponding CPU
SD1780	Power supply off detection status	Power supply off detection status	<ul style="list-style-type: none"> This register stores status of a redundant power supply module (Q6□RP) with input power off, in the following bit pattern. When the main base unit is not a redundant power main base unit (Q3□RB), "0" is stored. <ul style="list-style-type: none"> In a multiple CPU system, the status is stored only to CPU module No.1. 	S (Every END processing)	New	
SD1781	Power supply failure detection	Power supply failure detection status	<ul style="list-style-type: none"> This register stores failure detection status of a redundant power supply module (Q6□RP) in the following bit pattern. (After a failure is detected on a redundant power supply module, the bit corresponding to the failed module turns to "0" upon turning off the module.) When the main base unit is not a redundant power main base unit (Q3□RB), "0" is stored. <ul style="list-style-type: none"> In a multiple CPU system, the status is stored only to CPU module No.1. 	S (Every END processing)	New	Qn(H) ^{*2} QnPH ^{*2} QnPRH Rem QnU ^{*3}
SD1782	Momentary power failure detection counter for power supply 1*1	Momentary power failure detection count for power supply 1	<ul style="list-style-type: none"> This register counts the number of times of momentary power failure of the power supply 1/2. This register monitors the status of the power supply 1/2 mounted on a redundant power main base unit (Q3□RB) and counts the number of momentary power failures. The status of power supply 1/2 mounted on the extension base unit for redundant power supply system and the redundant type extension base unit is not monitored. 	S (Every END processing)	New	
SD1783	Momentary power failure detection counter for power supply 2*1	Momentary power failure detection count for power supply 2	<ul style="list-style-type: none"> When the CPU module starts, the counter of the power supply 1/2 is cleared to "0". If the input power to one of the redundant power supply modules is turned off, the corresponding counter is cleared to "0". The counter is incremented by one upon momentary power failure on the power supply 1 or 2. When the main base unit is not a redundant power main base unit (Q3□RB), "0" is stored. In a multiple CPU system, the status is stored only to CPU module No.1. The counter repeats increment and decrement of the value; 0→32767→32768→0. (The value is displayed within the range of 0 to 65535 on the device monitor window of GX Developer.) 	S (Every END processing)	New	

*1: The "power supply 1" indicates the redundant power supply module mounted on the POWER 1 slot of the redundant base unit (Q3□RB/Q6□RB/Q6□WRB). The "power supply 2" indicates the redundant power supply module mounted on the POWER 2 slot of the redundant base unit (Q3□RB/Q6□RB/Q6□WRB).

*2: This applies to modules whose serial No. (first five digits) is "07032" or later.

However, for the multiple CPU system configuration, this applies to all CPU modules whose serial No. (first five digits) is "07032" or later.

*3: This applies to modules with a serial number (first five digits) of "10042" or later.

Appendix 6 External Dimensions

(1) QJ71LP21-25, QJ71LP21G

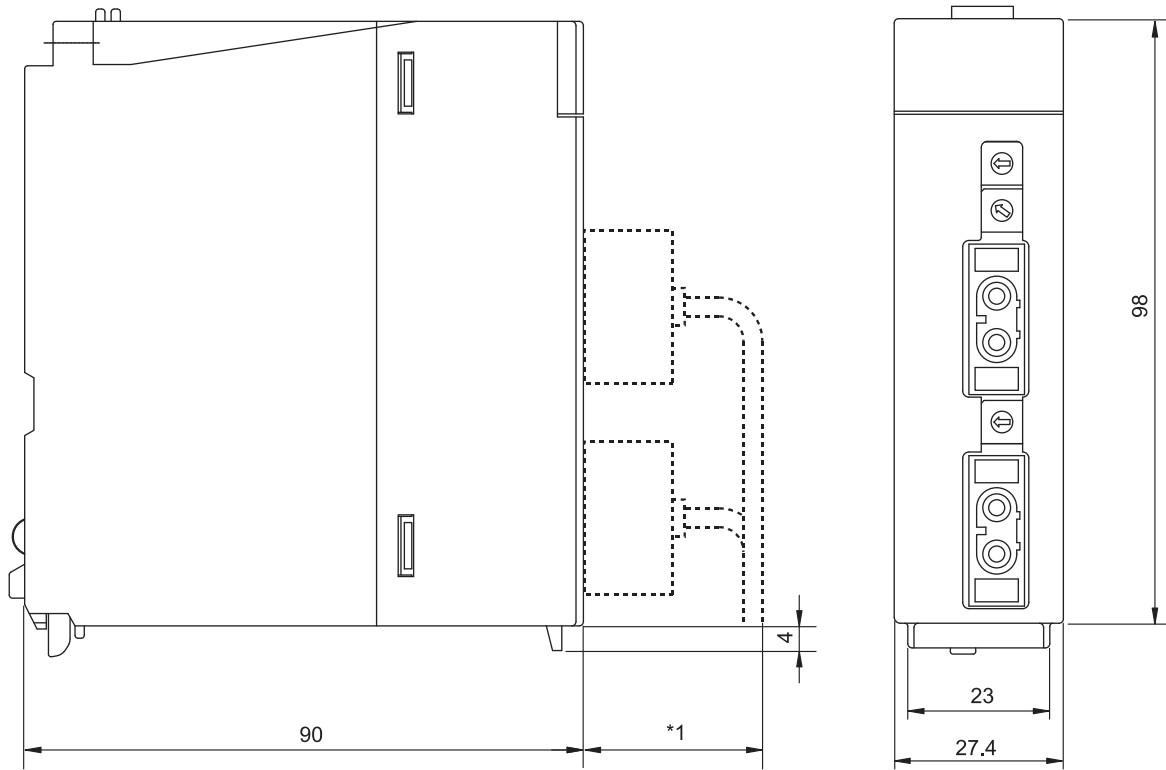

Unit: mm

*1: Please contact your nearest Mitsubishi Electric System & Service Co., Ltd. for details.

(2) QJ71LP21S-25

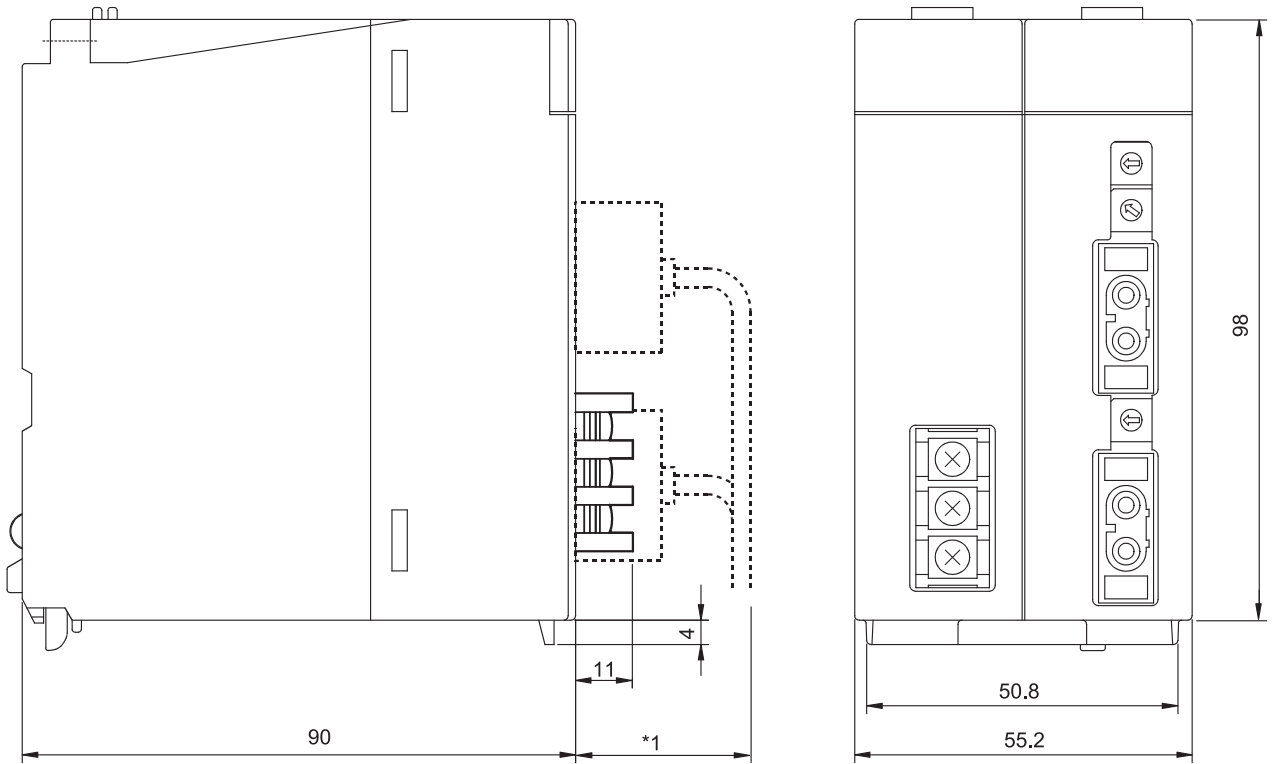

Unit: mm

*1: Please contact your nearest Mitsubishi Electric System & Service Co., Ltd. for details.

(3) QJ71BR11

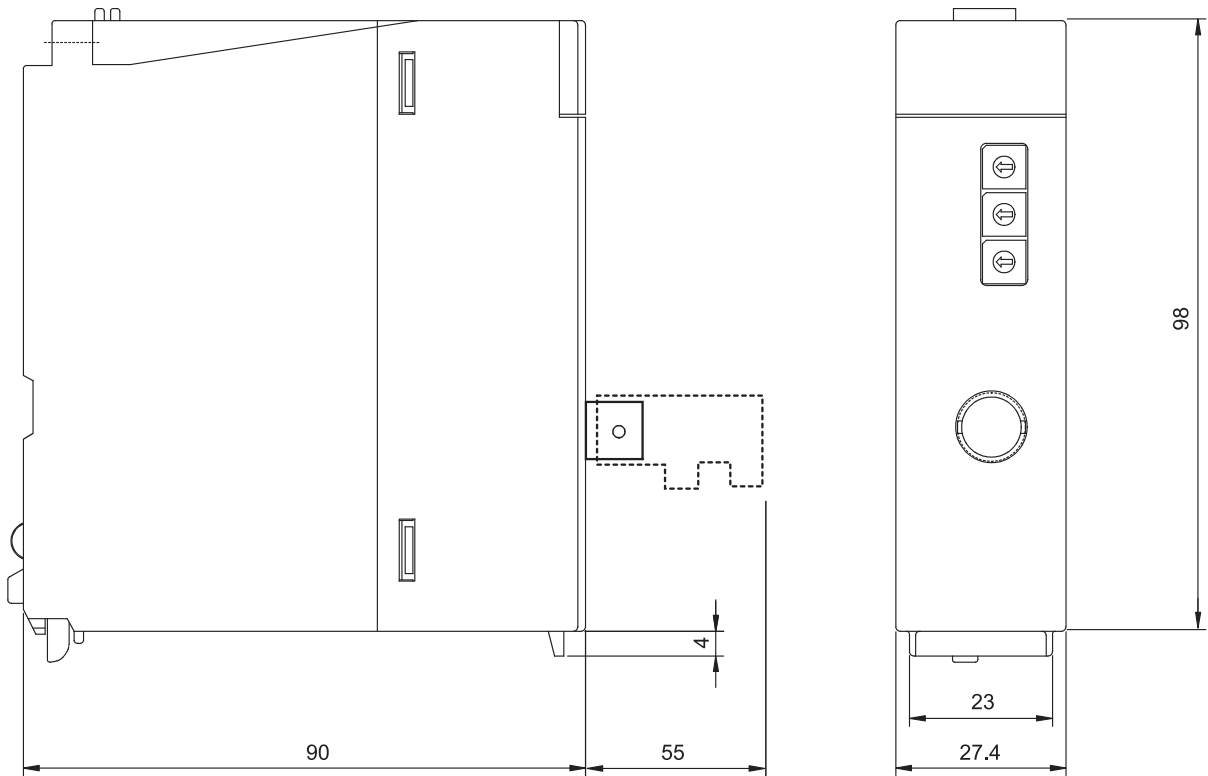

Unit: mm

(4) QJ72LP25-25, QJ72LP25G

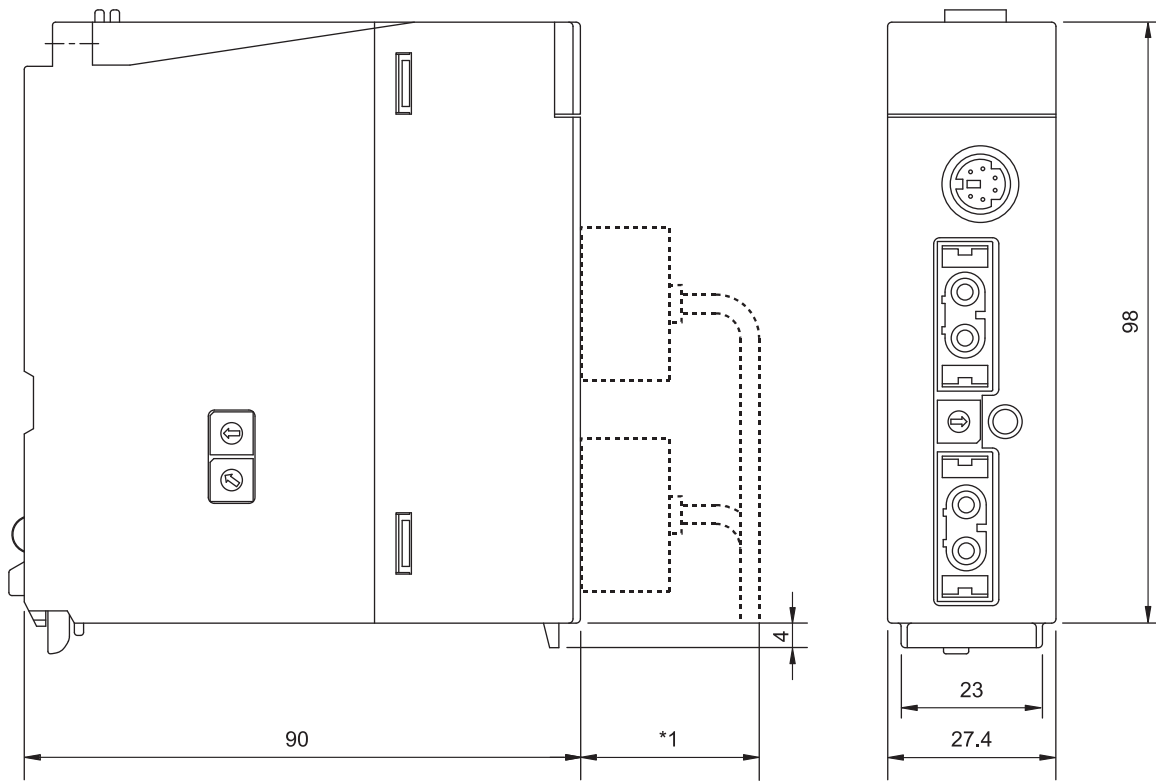

Unit: mm

*1: Please contact your nearest Mitsubishi Electric System & Service Co., Ltd. for details.

(5) QJ72BR15

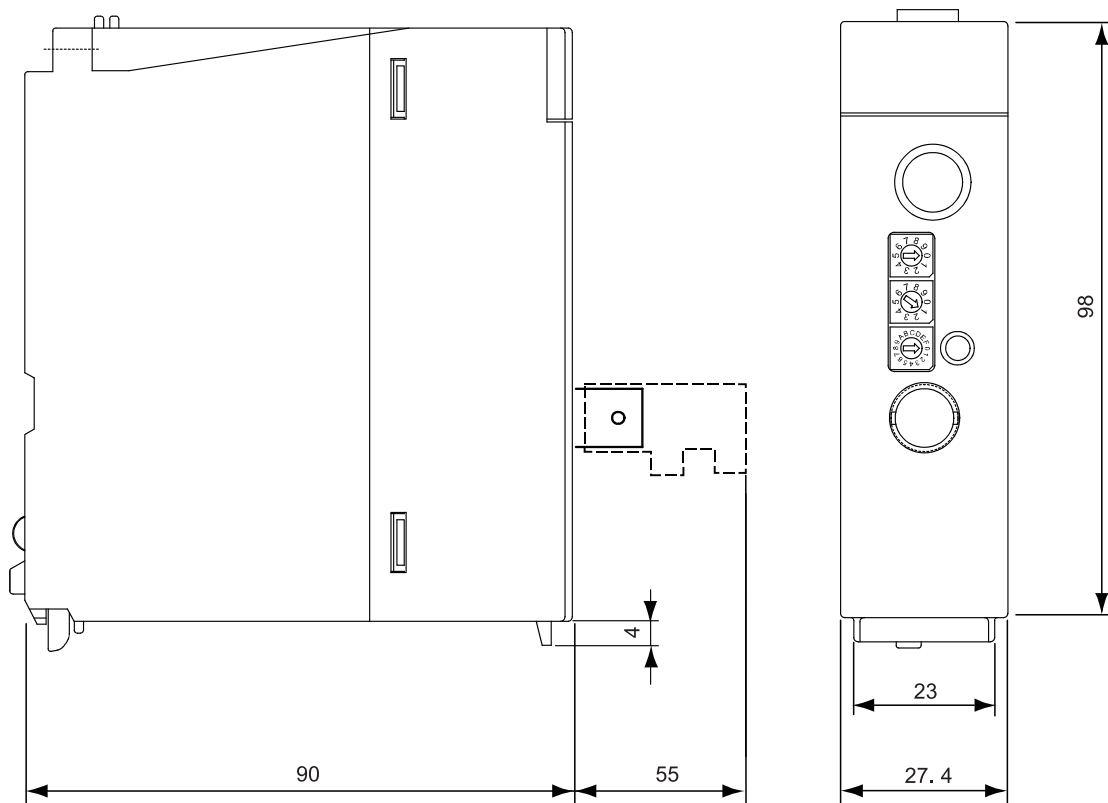

Unit: mm

INDEX

[A]
Applicable systems 2-13

[B]
Block data assurance per station 6-8

[C]
Coaxial cable 3-5
Common parameter
LX/LY setting 5-9
LB/LW setting 5-12
Specify reserved station 5-13
Cyclic transmission..... 3-11,6-7

[E]
END asynchronization 3-37,5-16
END synchronization..... 3-37
Error code
Error code list..... 8-38,8-48
Storage of the error codes of the dedicated instruction..... 8-37
Checking error codes with
GX Developer 8-32
Checking error codes with
GX Works2 8-34

[F]
Function 3-10

[G]
Group No.A-20,5-7

[H]
H/W information..... 8-65

[I]
Intelligent function module parameter
.....3-10,5-2,6-9

[L]
Link dedicated instruction 6-18,7-3
Link refresh 3-36
Link refresh assignment image..... 5-19
Link scan..... 3-37
Link special register (SW) 6-23,App-14

Link special relay (SB)..... 6-23,App-3

[M]
Master module A-18
Module error history 8-36
Multiple CPU system 2-19
Multiplex transmission 7-12

[N]
Network diagnosis
Error history monitor..... 8-12
Error history monitor details 8-14
Network monitor details 8-9
Station order check test 4-35
Communication test 4-36
Host station information 8-5
Setup confirmation test 4-31
Other station information 8-7
Loop test..... 4-33
Network setting
Starting I/O No..... 5-6
Network No..... 5-6
Total stations 5-6
Network test
Stopping/restarting the cyclic transmission 7-16
Stopping link refreshing 7-16

[O]
Operation mode
Online 5-7
Offline 5-7
Forward loop test 5-7
Reverse loop test 5-7
Optical fiber cable 3-4

[P]
Performance specifications
Coaxial cable system 3-3
Optical loop system..... 3-1

[R]
RAS function
Station detach function 3-21
Automatic return function 3-18
Diagnostic function..... 3-24

Loopback function	3-19
READ instruction	6-18,6-19
RECV instruction	6-19
RECVS instruction	6-19
Redundant power supply	3-25
Refresh parameter	5-19
REMFR instruction	6-18,7-3
Remote I/O module	A-18
REMTO instruction	6-18,7-4
REQ instruction	6-19
Routing function	7-2
RRUN instruction.....	6-20
RSTOP instruction	6-20
RTMRD instruction.....	6-20
RTMWR instruction.....	6-21

[S]

SEND instruction.....	6-19
Special register (SD) for remote I/O station	App-36
Special relay (SM) for remote I/O station	App-33
SREAD instruction	6-19
Supplementary settings	5-15
Switch setting	
Intelligent function module switch	7-15
Station number setting switch	4-3,4-5
Mode setting switch	4-4,4-5
SWRITE instruction.....	6-19
System error history	8-34

[T]

Test	
Self-loopback test	4-14
Forward loop/reverse loop test	4-28
Internal self-loopback test	4-14
Hardware test	4-14
Transient transmission	7-2

[W]

WRITE instruction	6-18,6-19
-------------------------	-----------

[Z]

ZNRD instruction	6-20,App-2
ZNWR instruction	6-20,App-2

[Number]

32-bit data assurance.....	6-7
----------------------------	-----

WARRANTY

Please confirm the following product warranty details before using this product.

1. Gratis Warranty Term and Gratis Warranty Range

If any faults or defects (hereinafter "Failure") found to be the responsibility of Mitsubishi occurs during use of the product within the gratis warranty term, the product shall be repaired at no cost via the sales representative or Mitsubishi Service Company.

However, if repairs are required onsite at domestic or overseas location, expenses to send an engineer will be solely at the customer's discretion. Mitsubishi shall not be held responsible for any re-commissioning, maintenance, or testing on-site that involves replacement of the failed module.

[Gratis Warranty Term]

The gratis warranty term of the product shall be for one year after the date of purchase or delivery to a designated place. Note that after manufacture and shipment from Mitsubishi, the maximum distribution period shall be six (6) months, and the longest gratis warranty term after manufacturing shall be eighteen (18) months. The gratis warranty term of repair parts shall not exceed the gratis warranty term before repairs.

[Gratis Warranty Range]

- (1) The range shall be limited to normal use within the usage state, usage methods and usage environment, etc., which follow the conditions and precautions, etc., given in the instruction manual, user's manual and caution labels on the product.
- (2) Even within the gratis warranty term, repairs shall be charged for in the following cases.
 1. Failure occurring from inappropriate storage or handling, carelessness or negligence by the user. Failure caused by the user's hardware or software design.
 2. Failure caused by unapproved modifications, etc., to the product by the user.
 3. When the Mitsubishi product is assembled into a user's device, Failure that could have been avoided if functions or structures, judged as necessary in the legal safety measures the user's device is subject to or as necessary by industry standards, had been provided.
 4. Failure that could have been avoided if consumable parts (battery, backlight, fuse, etc.) designated in the instruction manual had been correctly serviced or replaced.
 5. Failure caused by external irresistible forces such as fires or abnormal voltages, and Failure caused by force majeure such as earthquakes, lightning, wind and water damage.
 6. Failure caused by reasons unpredictable by scientific technology standards at time of shipment from Mitsubishi.
 7. Any other failure found not to be the responsibility of Mitsubishi or that admitted not to be so by the user.

2. Onerous repair term after discontinuation of production

- (1) Mitsubishi shall accept onerous product repairs for seven (7) years after production of the product is discontinued. Discontinuation of production shall be notified with Mitsubishi Technical Bulletins, etc.
- (2) Product supply (including repair parts) is not available after production is discontinued.

3. Overseas service

Overseas, repairs shall be accepted by Mitsubishi's local overseas FA Center. Note that the repair conditions at each FA Center may differ.

4. Exclusion of loss in opportunity and secondary loss from warranty liability

Regardless of the gratis warranty term, Mitsubishi shall not be liable for compensation to:

- (1) Damages caused by any cause found not to be the responsibility of Mitsubishi.
- (2) Loss in opportunity, lost profits incurred to the user by Failures of Mitsubishi products.
- (3) Special damages and secondary damages whether foreseeable or not, compensation for accidents, and compensation for damages to products other than Mitsubishi products.
- (4) Replacement by the user, maintenance of on-site equipment, start-up test run and other tasks.

5. Changes in product specifications

The specifications given in the catalogs, manuals or technical documents are subject to change without prior notice.

TRADEMARKS

The company names, system names and product names mentioned in this manual are either registered trademarks or trademarks of their respective companies.

In some cases, trademark symbols such as '™' or '®' are not specified in this manual.

SH(NA)-080124-W(2311)MEE

MODEL: Q-NET/H-R-I/O-E

MODEL CODE: 13JF96

MITSUBISHI ELECTRIC CORPORATION

HEAD OFFICE: TOKYO BLDG., 2-7-3, MARUNOUCHI, CHIYODA-KU, TOKYO 100-8310, JAPAN
NAGOYA WORKS: 1-14, YADA-MINAMI 5-CHOME, HIGASHI-KU, NAGOYA 461-8670, JAPAN

When exported from Japan, this manual does not require application to the
Ministry of Economy, Trade and Industry for service transaction permission.

Specifications subject to change without notice.