

FX INPUT AND OUTPUT TERMINAL BLOCKS

USER'S GUIDE

JY992D50401M 



This manual contains text, diagrams and explanations which will guide the reader in the correct installation and operation of the FX TERMINAL BLOCKS. It should be read and understood before attempting to install or use the unit. Further information can be found in the FX series PLC hardware manuals.

If in doubt at any stage during the installation of the FX TERMINAL BLOCKS always consult a professional electrical engineer who is qualified and trained to the local and national standards.

Note's on the symbology used in this manual

At various times through out this manual certain symbols will be used to highlight points of information which are intended to ensure the users personal safety and protect the integrity of the equipment. Whenever any of the following symbols are encountered, its associated note must be read and understood. Each of the symbols used will now be listed with a brief description of its meaning.

Hardware warnings

-  Indicates that the identified danger WILL cause physical and property damage.
-  Indicates that the identified danger could POSSIBLY cause physical and property damage.

Guidelines for the safety of the user and protection of the FX TERMINAL BLOCKS

- This manual has been written to be used by trained and competent personnel. This is defined by the European directives for machinery, low voltage and EMC.
- If in doubt at any stage during the installation of the FX TERMINAL BLOCKS always consult a professional electrical engineer who is qualified and trained to the local and national standards. If in doubt about the operation or use of the FX TERMINAL BLOCKS please consult the nearest Mitsubishi Electric distributor.
- Under no circumstances will Mitsubishi Electric be liable or responsible for any consequential damage that may arise as a result of the installation or use of this equipment.
- All examples and diagrams shown in this manual are intended only as an aid to understanding the text, not to guarantee operation. Mitsubishi Electric will accept no responsibility for actual use of the product based on these illustrative examples.
- Owing to the very great variety in possible application of this equipment, you must satisfy yourself as to its suitability for your specific application.

1. INTRODUCTION

Terminal blocks convert I/O terminals of connector type PLC into terminal blocks. Some terminal blocks directly extend inputs and outputs of PLC. Other terminal blocks are equipped with diversified built-in devices, and function only as inputs or only as outputs.

MODEL	INPUT	OUTPUT	APPLICABLE PLC	CURRENT CONSUMPTION
FX-16E-TB/UL	16 pt (Direct input/output)		FX2C-□□MT-ESS/UL FX2NC-□□MT-D/UL	—
FX-32E-TB/UL	32 pt or 16/16 pt (Direct input/output)		FX2NC-□□EX-D/UL FX2NC-□□EYT-D/UL	
FX-16EYR-ES-TB/UL	—	16 pt (Relay)		80mA (5mA/1pt)
FX-16EYS-ES-TB/UL	—	16 pt (Triac)		
FX-16EYT-ESS-TB/UL	—	16 pt (Transistor source)	FX2C-□□MT-ESS/UL FX2NC-□□MT-D/UL	112mA (7mA/1pt)
FX-16EYT-ES-TB/UL	—	16 pt (Transistor sink)	FX2NC-□□EYT-D/UL	
FX-16EX-A1-TB/UL	16 pt (100V AC)	—	FX2C-□□MT-E/UL	48mA (3mA/1pt)

MODEL	INPUT	OUTPUT	APPLICABLE PLC	CURRENT CONSUMPTION
FX-16E-TB	16 pt (Direct input/output)		FX2NC-□□MT-D/UL FX2NC-□□EX-D/UL	—
FX-32E-TB	32 pt or 16/16 pt (Direct input/output)		FX2NC-□□EYT-D/UL	
FX-16EYR-TB	—	16 pt (Relay)		80mA (5mA/1pt)
FX-16EYT-TB	—	16 pt (Transistor sink)	FX2NC-□□MT-D/UL FX2NC-□□EYT-D/UL	112mA (7mA/1pt)
FX-16EX-A1-TB	16 pt (100V AC)	—	FX2NC-□□MT-D/UL FX2NC-□□EX-D/UL	48mA (3mA/1pt)

2. EXTERNAL DIMENSION

FX-16E-TB/UL, FX-16E-TB
FX-16EY□(□: R/T/S)-TB/UL
FX-16EY□(□: R/T)-TB
FX-16EX-A1-TB/UL, FX-16EX-A1-TB

FX-32E-TB/UL
FX-32E-TB

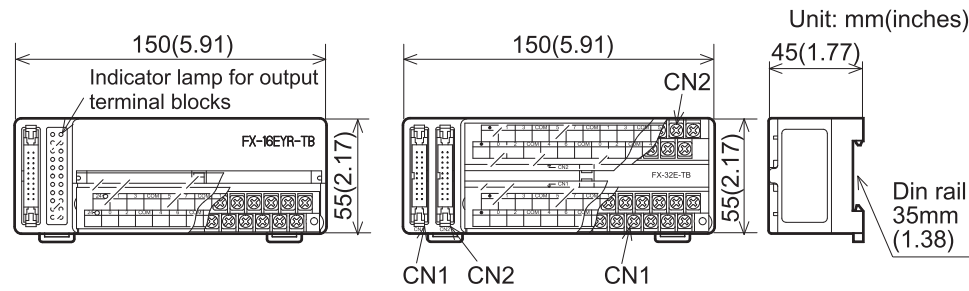

Accessories

- Input / output extension block labels
- Terminal layout cards

3. CONFIGURATION AND OPTIONS

FX2C, FX2NC PLC

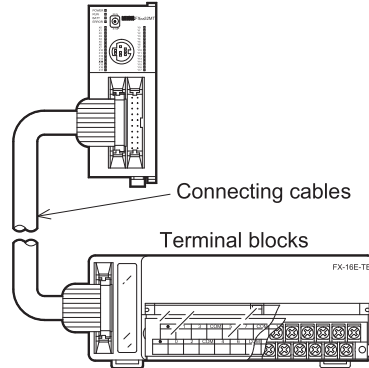

STANDARD PRE TERMINATED CABLES		
LENGTHS	FLAT CABLES	ROUND CABLES
1.5 m (4.9 ft)	FX-16E-150CAB	FX-16E-150CAB-R
3.0 m (9.8 ft)	FX-16E-300CAB	FX-16E-300CAB-R
5.0 m (16.4 ft)	FX-16E-500CAB	FX-16E-500CAB-R

4. CONNECTOR CABLE PIN CONFIGURATION

PLC	TERMINAL BLOCKS
(): Pin No.	(): Pin No.
X/Y000 (1)	(1) X/Y000 (11) X/Y010
X/Y001 (2)	(2) X/Y001 (12) X/Y011
X/Y002 (3)	(3) X/Y002 (13) X/Y012
X/Y003 (4)	(4) X/Y003 (14) X/Y013
X/Y004 (5)	(5) X/Y004 (15) X/Y014
X/Y005 (6)	(6) X/Y005 (16) X/Y015
X/Y006 (7)	(7) X/Y006 (17) X/Y016
X/Y007 (8)	(8) X/Y007 (18) X/Y017
COM (9)	(9) COM (19) COM
● (10)	(10) ● (20) ●

The connections required between the FX2C, FX2NC main unit and a terminal block are shown in the diagram below with an example for inputs X000 to X017 and outputs Y000 to Y017.

The I/O connector should be the 20-pin type and should conform to MIL C 83503 of Military Standard.

5. TERMINAL WIRING

 Never perform external wiring to unused terminals □. Such wiring may damage the unit.

Note

- ☆ Do not lay I/O cables next to power cables or allow them to share the same trunking duct.
- ☆ Where I/O signals are used over an extended distance consideration must be made for voltage drop and noise interference.
- ☆ Use crimp-style terminals of the dimensions shown in the figure below.
- ☆ Tighten terminals at a torque of 0.5 to 0.8 N·m (4.4 to 7.1 lbf·in). Do not tighten the terminal block mounting screws with a torque outside the above-mentioned range. Failure to do so may cause equipment failures or malfunctions.

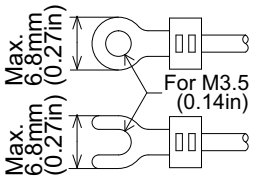

6. DIRECT INPUT BLOCKS AND DIRECT OUTPUT BLOCKS WIRING

Internal circuit

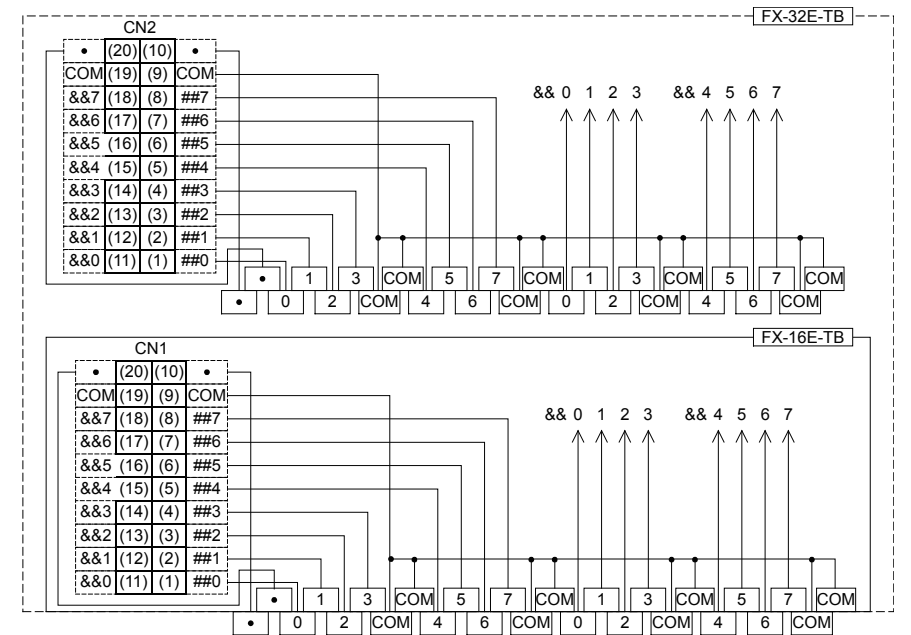

(9) and (19) of both CN1 and CN2 are short-circuited internally.

Inputs

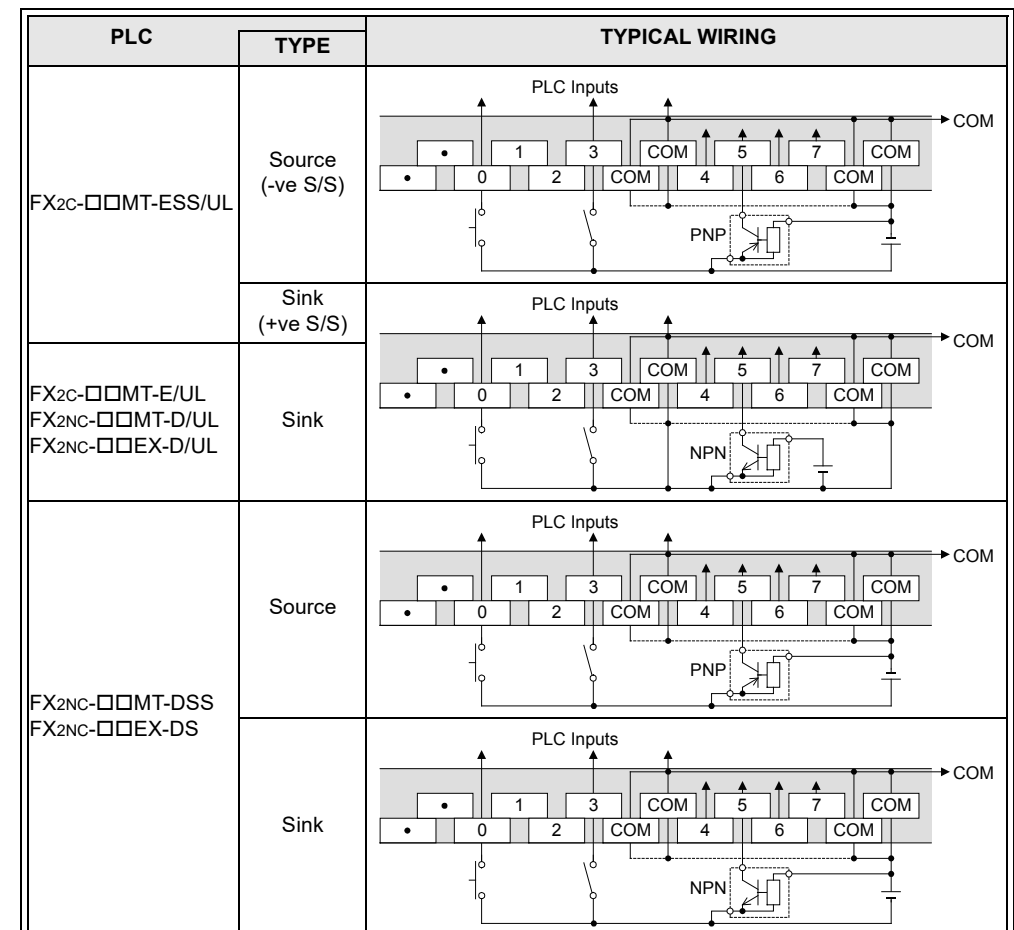

Outputs

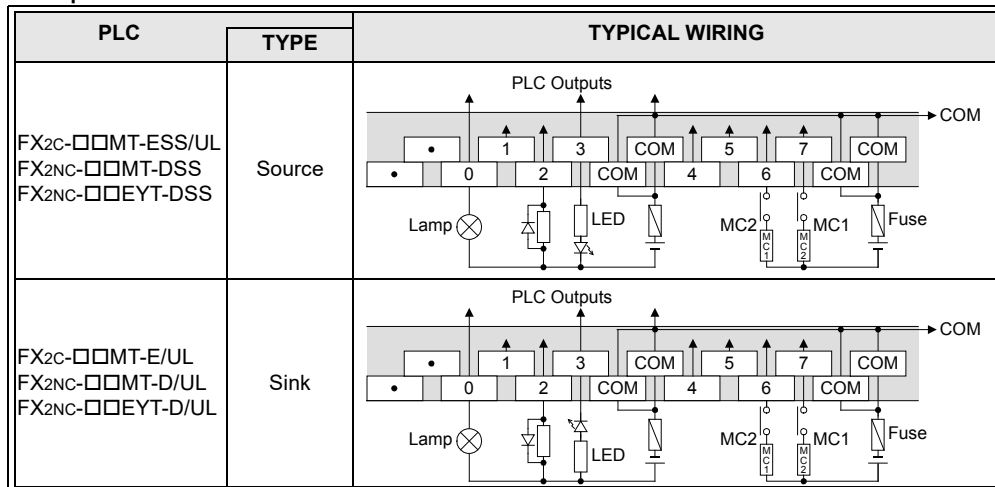

For the I/O specifications and detailed information, refer to the FX2C Hardware Manual or the FX2NC Hardware Manual.

7. AC INPUT BLOCK WIRING

Specifications

Input	Voltages	85 - 132V AC 50/60Hz
	Impedance	21kΩ / 50Hz 18kΩ / 60Hz
	Current	6.2mA 110V AC/60Hz 4.7mA 100V AC/50Hz
Circuit isolation		Photocoupler
Operation indication		LED of base unit
Switch Rating	OFF ⇒ ON	80V 3.8mA
	ON ⇒ OFF	30V 1.7mA
Response time		30ms or less
Signal input supply		24V DC 3mA/1pt

Typical wiring

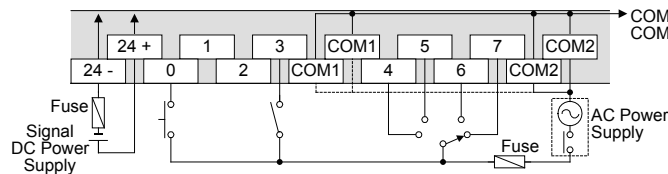

8. OUTPUT BLOCKS WIRING

Outputs specification

	RELAY	TRIAC	TRANSISTOR
Switched voltages	Less than 250V AC 30V DC	Between 85 - 242V AC	5 - 30V DC
Circuit isolation	By relay coil	Photocoupler	Photocoupler of base unit
Operation indication	LED is lit when coil is active.	LED is lit when output is active.	LED is lit when output is active.
Maximum load	resistive	2A/pt 8A/4pts(com)	0.5A/pt 0.8A/4pts(com)
	inductive	80VA	15VA, 100V AC 36VA, 240V AC
	indicator	100W	30W
Leakage current	—	1mA, 100V AC 2mA, 200V AC	0.1mA 30V DC
Minimum load	2mA 5V DC	0.4VA, 100V AC 1.6VA, 200V AC	—
Response time	OFF⇒ON	Approx. 10ms	Approx. 0.2ms
	ON⇒OFF		Approx. 1.5ms
Indicator input supply	24V DC 5mA/1pt	24V DC 7mA/1pt	24V DC 7mA/1pt

Relay output blocks FX-16EYR-ES-TB/UL, FX-16EYR-TB wiring

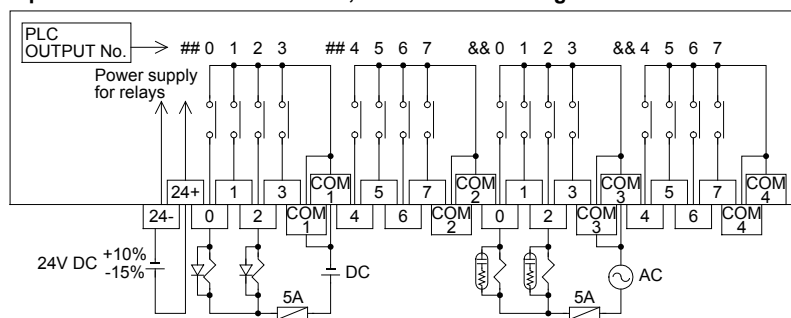

Terminal blocks are not equipped with built-in fuses. In order to prevent breakdown of circuits caused by load short-circuit, provide a fuse of 5 to 10 A for every four points.

[DC LOAD]

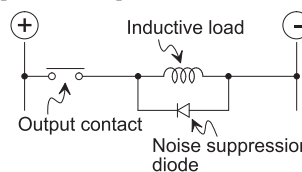

Connect a noise suppression diode to a DC inductive load in parallel. If the diode is not connected, the life time of the contact becomes considerably shorter. Select a noise suppression diode whose reverse withstand voltage is 5 to 10 times or more the load voltage and whose current in the forward direction is not less than the load current.

[AC LOAD]

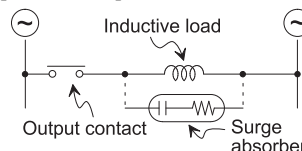

When a surge absorber is connected to an AC inductive load in parallel, noise generation is reduced.
0.1 μF capacitor + 100 to 120 Ω resistor

The standard life time of contactors and solenoid valves against AC inductive load is 500,000 times of actuation against 35 VA.

The table below shows the guideline of the life time of relays based on the result of the life time test performed in our company.

Have in mind that the life time of a relay contact becomes considerably shorter even in the condition below if the rush current is shut down.

LOAD CAPACITY (Test condition: ON for 1 second and OFF for 1 second)	LIFE TIME OF CONTACT	EXAMPLE OF APPLICABLE LOAD (Magnetic switch manufactured by our company)
80VA	0.8A / 100V AC 0.4A / 200V AC	1,000,000 times S-K180 ~ S-K400
120VA	1.2 / 100V AC 0.6A / 200V AC	200,000 times S-K600, S-K800

Triac output block FX-16EYS-ES-TB/UL wiring

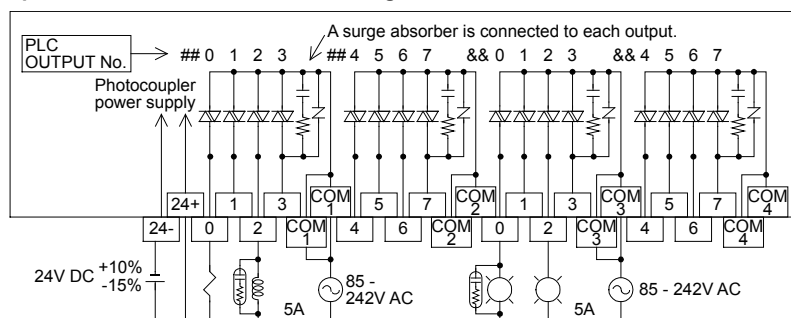

Terminal blocks are not equipped with built-in fuses. In order to prevent breakdown of circuits caused by load short-circuit, provide a fuse of 5 to 10 A for every four points.

[MINUTE CURRENT LOAD]

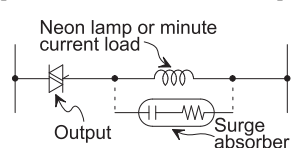

To a neon lamp or a minute current load of 0.4VA/100V AC, 1.6VA/200V AC or less, connect a surge absorber in parallel.

[OUTPUT CURRENT]

The current of 0.3 A can flow in each output point. However, in order to restrict temperature rise, flow 0.8 A to every four output points (= 0.2 A per point on an average). When turning on and off frequently a load with large rush current, set the square average current to 0.2 A or less.

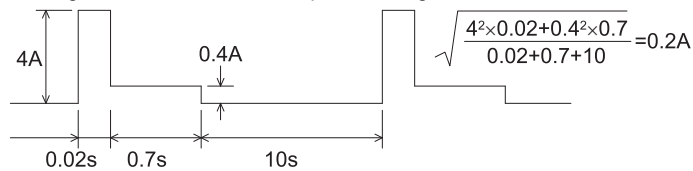

Transistor output blocks wiring

FX-16EYT-ESS-TB/UL (source)

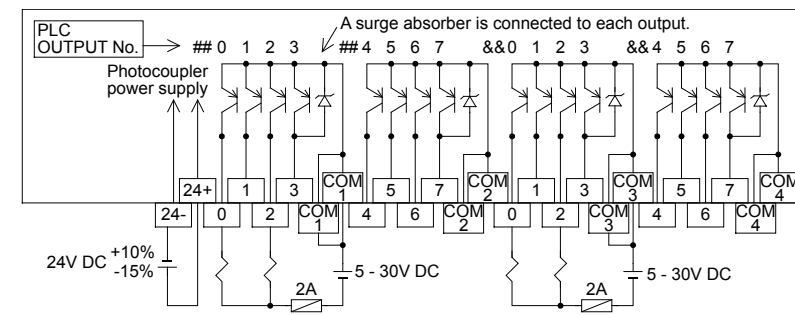

FX-16EYT-ES-TB/UL, FX-16EYT-TB (sink)

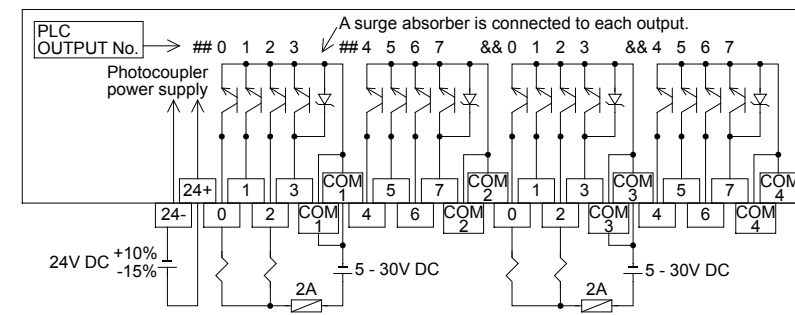

Terminal blocks are not equipped with built-in fuses. In order to prevent breakdown of circuits caused by load short-circuit, provide a fuse of 2 A for every four points.

[ON VOLTAGE]

The ON voltage of an output transistor is approximately 1.5 V.

When driving a semiconductor device, etc., pay attention to the input voltage characteristics of the used device.

「电器电子产品有害物质限制使用标识要求」的表示方式



Note: This symbol mark is for China only.

含有有害6物质的名称, 含有量, 含有部品
本产品中所含有的有害6物质的名称, 含有量, 含有部品如下表所示。

产品中有害物质的名称及含量

部件名称	有害物质					
	铅 (Pb)	汞 (Hg)	镉 (Cd)	六价铬 (Cr (VI))	多溴联苯 (PBB)	多溴二苯醚 (PBDE)
可编程控制器	外壳	○	○	○	○	○
	印刷基板	×	○	○	○	○

本表格依据SJ/T 11364的规定编制。

○: 表示该有害物质在该部件所有均质材料中的含量均在GB/T 26572规定的限量要求以下。
×: 表示该有害物质至少在该部件的某一均质材料中的含量超出GB/T 26572规定的限量要求。

基于中国标准法的参考规格: GB/T15969.2

Manual number: JY992D50401

Manual revision: M

Date: July 2024

MITSUBISHI ELECTRIC CORPORATION

HEAD OFFICE: TOKYO BUILDING, 2-7-3 MARUNOUCHI, CHIYODA-KU, TOKYO 100-8310, JAPAN

JY992D50401M

Effective July 2024

Specifications are subject to change without notice