



**MITSUBISHI
ELECTRIC**

Programmable Controller
MELSEC-F

USER'S MANUAL



FX3U-32DP PROFIBUS-DP Interface Block



FX3U

Safety Precautions

(Read these precautions before use.)

Before installation, operation, maintenance or inspection of this product, thoroughly read through and understand this manual and all of the associated manuals. Also, take care to handle the module properly and safely.

This manual classifies the safety precautions into two categories:  **WARNING** and  **CAUTION**.

 WARNING	Indicates that incorrect handling may cause hazardous conditions, resulting in death or severe injury.
 CAUTION	Indicates that incorrect handling may cause hazardous conditions, resulting in medium or slight personal injury or physical damage.

Depending on the circumstances, procedures indicated by  **CAUTION** may also cause severe injury. It is important to follow all precautions for personal safety.

Store this manual in a safe place so that it can be taken out and read whenever necessary. Always forward it to the end user.

1. DESIGN PRECAUTIONS



 WARNING	Reference Page
<ul style="list-style-type: none"> • Make sure to have the following safety circuits outside of the PLC to ensure safe system operation even during external power supply problems or PLC failure. Otherwise, malfunctions may cause serious accidents. <ol style="list-style-type: none"> 1) Most importantly, have the following: an emergency stop circuit, a protection circuit, an interlock circuit for opposite movements (such as normal vs. reverse rotation), and an interlock circuit (to prevent damage to the equipment at the upper and lower positioning limits). 2) Note that when the PLC CPU detects an error, such as a watchdog timer error, during self-diagnosis, all outputs are turned off. Also, when an error that cannot be detected by the PLC CPU occurs in an input/output control block, output control may be disabled. External circuits and mechanisms should be designed to ensure safe machinery operation in such a case. 3) Note that when an error occurs in a relay, triac or transistor output device, the output could be held either on or off. For output signals that may lead to serious accidents, external circuits and mechanisms should be designed to ensure safe machinery operation in such a case. 	20 23

 CAUTION	Reference Page
<ul style="list-style-type: none"> • Make sure to observe the following precautions in order to prevent any damage to the machinery or accidents due to abnormal data written to the PLC under the influence of noise: <ol style="list-style-type: none"> 1) Do not bundle the main circuit line together with or lay it close to the main circuit, high-voltage line, or load line. Otherwise, noise disturbance and/or surge induction are likely to take place. As a guideline, lay the control line at least 100mm (3.94") or more away from the main circuit, high-voltage line, or load line. 2) Ground the shield wire or shield of the shielded cable at one point on the PLC. However, do not ground them at the same point as the high-voltage lines. • Install module so that excessive force will not be applied to peripheral device connectors. Failure to do so may result in wire damage/breakage or PLC failure. 	20 23 27



Safety Precautions

(Read these precautions before use.)

2. INSTALLATION PRECAUTIONS

 WARNING	Reference Page
<ul style="list-style-type: none">• Make sure to cut off all phases of the power supply externally before attempting installation or wiring work. Failure to do so may cause electric shock.	23
 CAUTION	Reference Page
<ul style="list-style-type: none">• Use the product within the generic environment specifications described in the PLC main unit manual (Hardware Edition). Never use the product in areas with dust, oily smoke, conductive dusts, corrosive gas (salt air, Cl₂, H₂S, SO₂, or NO₂), flammable gas, vibration or impacts, or exposed to high temperature, condensation, or wind and rain. If the product is used in such conditions, electric shock, fire, malfunction, deterioration or damage may occur.• Install the product securely using a DIN rail or mounting screws.• Install the product on a flat surface. If the mounting surface is rough, undue force will be applied to the PC board, thereby causing nonconformities.• When drilling screw holes or wiring, make sure cutting or wire debris does not enter the ventilation slits. Failure to do so may cause fire, equipment failures or malfunctions.• Be sure to remove the dust proof sheet from the PLC's ventilation port when the installation work is completed. Failure to do so may cause fire, equipment failures, and malfunctions.• Do not touch the conductive parts of the product directly to avoid failure or malfunctions.	23

3. WIRING PRECAUTIONS

 WARNING	Reference Page
<ul style="list-style-type: none">• Cut off all phases of the power supply externally before installation or wiring work in order to avoid damage to the product or electric shock.	27
 CAUTION	Reference Page
<ul style="list-style-type: none">• When drilling screw holes or wiring, make sure cutting or wire debris does not enter the ventilation slits. Failure to do so may cause fire, equipment failures or malfunctions.	27

Safety Precautions

(Read these precautions before use.)

4. STARTUP AND MAINTENANCE PRECAUTIONS

 WARNING	Reference Page
<ul style="list-style-type: none">• Do not touch any terminal while the PLC's power is on. Doing so may cause electric shock or malfunctions.• Before cleaning or retightening terminals, externally cut off all phases of the power supply. Failure to do so may cause electric shock.• Before modifying or disrupting the program in operation or running the PLC, carefully read through this manual and the associated manuals and ensure the safety of the operation. An operation error may damage the machinery or cause accidents.	20 51 54 62

 CAUTION	Reference Page
<ul style="list-style-type: none">• Do not disassemble or modify the unit. Doing so may cause fire, equipment failures, or malfunctions. * For repair, contact your local Mitsubishi Electric representative.• Do not drop the product or expose the product to strong impacts, as doing so may cause product damage.• Turn off the power to the PLC before attaching or detaching the peripheral devices. Failure to do so may cause equipment failures or malfunctions.	20 51 54 62

5. DISPOSAL PRECAUTIONS

 CAUTION	Reference Page
<ul style="list-style-type: none">• Please contact a certified electronic waste disposal company for the environmentally safe recycling and disposal of your device.	21

6. TRANSPORTATION AND STORAGE PRECAUTIONS

 CAUTION	Reference Page
<ul style="list-style-type: none">• The PLC is a precision instrument. During transportation, avoid impacts larger than those specified in the general specifications of the PLC main unit manual by using dedicated packaging boxes and shock-absorbing palettes. Failure to do so may cause failures in the PLC. After transportation, verify operation of the PLC and check for damage of the mounting part, etc.	21

Safety Precautions

(Read these precautions before use.)

MEMO

FX3U-32DP PROFIBUS-DP Interface Block

User's Manual

Manual number	JY997D25201
Manual revision	G
Date	10/2022

Foreword

This manual contains text, diagrams and explanations which will guide the reader in the correct installation, safe use and operation of the FX3U-32DP and should be read and understood before attempting to install or use the unit.

Store this manual in a safe place so that you can take it out and read it whenever necessary. Always forward it to the end user.

This manual confers no industrial property rights or any rights of any other kind, nor does it confer any patent licenses. Mitsubishi Electric Corporation cannot be held responsible for any problems involving industrial property rights which may occur as a result of using the contents noted in this manual.

Outline Precautions

- This manual provides information for the use of the FX3U-32DP. The manual has been written to be used by trained and competent personnel. The definition of such a person or persons is as follows;
 - a) Any engineer who is responsible for the planning, design and construction of automatic equipment using the product associated with this manual should be of a competent nature, trained and qualified to the local and national standards required to fulfill that role. These engineers should be fully aware of all aspects of safety with regards to automated equipment.
 - b) Any commissioning or service engineer must be of a competent nature, trained and qualified to the local and national standards required to fulfill that job. These engineers should also be trained in the use and maintenance of the completed product. This includes being completely familiar with all associated documentation for the said product. All maintenance should be carried out in accordance with established safety practices.
 - c) All operators of the completed equipment should be trained to use that product in a safe and coordinated manner in compliance to established safety practices. The operators should also be familiar with documentation which is connected with the actual operation of the completed equipment.

Note: The term 'completed equipment' refers to a third party constructed device which contains or uses the product associated with this manual

- This product has been manufactured as a general-purpose part for general industries, and has not been designed or manufactured to be incorporated in a device or system used in purposes related to human life.
- Before using the product for special purposes such as nuclear power, electric power, aerospace, medicine or passenger movement vehicles, consult with Mitsubishi Electric.
- This product has been manufactured under strict quality control. However when installing the product where major accidents or losses could occur if the product fails, install appropriate backup or failsafe functions in the system.
- When combining this product with other products, please confirm the standard and the code, or regulations with which the user should follow. Moreover, please confirm the compatibility of this product to the system, machine, and apparatus with which the user is using.
- If in doubt at any stage during the installation of the product, always consult a professional electrical engineer who is qualified and trained to the local and national standards. If in doubt about the operation or use, please consult the nearest Mitsubishi Electric representative.
- Since the examples indicated by this manual, technical bulletin, catalog, etc. are used as a reference, please use it after confirming the function and safety of the equipment and system. Mitsubishi Electric will accept no responsibility for actual use of the product based on these illustrative examples.
- This manual content, specification etc. may be changed without a notice for improvement.
- The information in this manual has been carefully checked and is believed to be accurate; however, if you have noticed a doubtful point, a doubtful error, etc., please contact the nearest Mitsubishi Electric representative.

Registration

The company names, system names and product names mentioned in this manual are either registered trademarks or trademarks of their respective companies.

In some cases, trademark symbols such as '™' or '®' are not specified in this manual.

Table of Contents

SAFETY PRECAUTIONS	(i)
Table of Contents	3
Applicable Standards	6
Location and Usage of Manual	8
Associated Manuals	9
Generic Terms and Abbreviations	12
Reading of the Manual	14

1. Introduction **15**

1.1 Product Outline and Features	15
1.2 External Dimensions	16
1.2.1 External Dimensions and Part Names	16
1.2.2 PROFIBUS-DP Connector Pin Assignment	17
1.3 Network Configuration	17
1.3.1 Applicable PROFIBUS-DP Network	17
1.3.2 Applicable PLC	18
1.4 FROM/TO Execution Time	18
1.5 System Start-up Procedure	19

2. Specifications **20**

2.1 General Specifications	21
2.2 Power Supply Specifications	21
2.3 Performance Specifications	22

3. Installation **23**

3.1 Installation Arrangements	24
3.2 Mounting	25
3.2.1 Direct Mounting	25
3.2.2 DIN Rail Mounting	26

4. Wiring **27**

4.1 Applicable Cable and Connector	27
4.2 PROFIBUS-DP Wiring	28
4.3 Grounding	28
4.4 Bus Terminator	28

5. Communication Outline on PROFIBUS-DP Network **29**

5.1 Cyclic Input/Output Data Communication	29
5.1.1 Cyclic Data Consistency	30
5.2 Acyclic Input/Output Data Communication	31
5.2.1 Acyclic Data Consistency	32
5.3 Diagnostic Data Communication	33
5.3.1 Diagnostic Data Communication	33
5.4 Global Control	34
5.4.1 SYNC and UNSYNC Global Control	34
5.4.2 FREEZE and UNFREEZE Global Control	35

6. Buffer Memory Allocation

36

6.1 Buffer Memory (BFM) List	36
6.2 Cyclic I/O Data Area Compatible with FX0N-32NT-DP [BFM #0 to BFM #19]	37
6.3 Data Exchange Status Register [BFM #20]	38
6.4 Swap Byte Order [BFM #21 Bit0 and Bit1]	38
6.5 Cyclic Input Data Length [BFM #22]	38
6.6 Cyclic Output Data Length [BFM #23]	38
6.7 Transmission Speed [BFM #24]	39
6.8 DP Communication Status Register [BFM #25]	39
6.9 PROFIBUS Module ID [BFM #26]	40
6.10 Slave Address [BFM #27]	40
6.11 User Diagnostics [BFM #28]	40
6.12 Error Status Register [BFM #29 Bit0 to Bit13]	41
6.13 Module ID Code [BFM #30]	41
6.14 Master Address [BFM #33]	41
6.15 Allocated Group ID Number [BFM #34]	42
6.16 DP-V1 Communication Parameter [BFM #35]	42
6.17 Start/Stop DP Communication [BFM #36 Bit0]	43
6.18 Consistency Handling Error Flags [BFM #37]	43
6.19 Setting Error Flag [BFM #38]	44
6.20 Cyclic Input Data Consistency Activate/Deactivate Flag [BFM #98 Bit0]	45
6.21 Cyclic Input Data Send Flag [BFM #99 Bit0]	45
6.22 Cyclic Input Data Send Area [BFM #100 to #171]	45
6.23 Cyclic Output Data Consistency Activate/Deactivate Flag [BFM #298 Bit0]	45
6.24 Cyclic Output Data Read Flag [BFM #299 Bit0]	45
6.25 Cyclic Output Data Receive Area [BFM #300 to #371]	46
6.26 Acyclic Input Data Send Flag (Class1) [BFM #499 Bit0]	46
6.27 Acyclic Input Data Send Area (Class1) [BFM #500 to #572]	46
6.28 Acyclic Output Data Read Flag (Class1) [BFM #699 Bit0]	46
6.29 Acyclic Output Data Receive Area (Class1) [BFM #700 to #772]	47
6.30 Acyclic Input Data Send Flag (Class2) [BFM #899 Bit0]	47
6.31 Acyclic Input Data Send Area (Class2) [BFM #900 to #972]	47
6.32 Acyclic Output Data Read Flag (Class2) [BFM #1099 Bit0]	47
6.33 Acyclic Output Data Receive Area (Class2) [BFM #1100 to #1172]	48
6.34 Reset Extended Diagnostic/Alarm Data Area Flag [BFM #1298]	48
6.35 Alarm/Status Switch [BFM #1299 Bit0]	48
6.36 Diagnostic/Alarm Immediate Send Flag [BFM #1300 Bit0]	49
6.37 Diagnostic/Alarm (Status) Data Area	49
6.37.1 Master Address [BFM #1301]	49
6.37.2 ID Number [BFM #1302]	49
6.37.3 Block Length [BFM # 1303]	50
6.37.4 Alarm/Status Type [BFM #1304]	50
6.37.5 Slot Number [BFM #1305]	50
6.37.6 Specifier [BFM #1306]	50
6.37.7 Extended Alarm Data [BFM #1307]	50
6.37.8 Extended Alarm Data [BFM #1308]	50
6.37.9 Extended Diagnostic/Alarm(Status) Data Area [BFM #1309 to #1322]	50

7. Parameter Setting and Network Configuration [GX Configurator-DP]	51
7.1 Slave Parameter Settings	52
7.1.1 Slave Properties	52
7.1.2 Extended User Parameters	52
7.1.3 Slave Modules	53
7.2 Network Configuration.....	53
8. Example Program	54
8.1 Example Program	54
8.1.1 System Configuration	54
8.1.2 Contents of Operation	54
8.1.3 Setting Network Configuration and Parameter for Example Program	55
8.1.4 Example Program for Cyclic Communication using GX Developer	58
8.1.5 Example Program for Cyclic Communication using GX IEC Developer (Ver. 7.00 or later).....	59
8.1.6 Example Program for Acyclic Communication using GX Developer	60
8.1.7 Example Program for Acyclic Communication using GX IEC Developer (Ver. 7.00 or later)	61
9. Diagnostics	62
9.1 Check LEDs	63
9.2 Checking Errors	64
Warranty	65
Revised History	66

Applicable Standards

Certification of UL, cUL Standards

The following product has UL and cUL certification.

UL, cUL File Number: E95239

Models: FX3U-32DP

Compliance with EC Directive (CE Marking)

This note does not guarantee that an entire mechanical module produced in accordance with the contents of this note will comply with the following standards.

Compliance to EMC and LVD directives for the entire mechanical module should be checked by the user / manufacturer. For more details please contact your local Mitsubishi Electric sales site.

1. Requirement for Compliance with EMC Directive

The following products have shown compliance through direct testing (of the identified standards below) and design analysis (through the creation of a technical construction file) to the European Directive for Electromagnetic Compatibility (2014/30/EU) when used as directed by the appropriate documentation.

Attention

This product is designed for use in industrial applications.

Type: Programmable Controller (Open Type Equipment)

Models: MELSEC FX3U series products, identified here, manufactured from
March 1st, 2007. FX3U-32DP

Standard	Tests
EN61131-2:2007 Programmable controller - Equipment requirements and tests	Compliance with all relevant aspects of the standard. EMI • Radiated Emission • Conducted Emission EMS • Radiated electromagnetic field • Fast transient burst • Electrostatic discharge • High-energy surge • Voltage drops and interruptions • Conducted RF • Power frequency magnetic field

Caution for Compliance with EC Directive

- Installation in Enclosure
Programmable controllers are open-type devices that must be installed and used within conductive control cabinets. Please use the programmable controller while installed within a conductive shielded control cabinet. Please secure the cabinet door to the control cabinet (for conduction). Installation within a control cabinet greatly affects the safety of the system and aids in shielding noise from the programmable controller.
- Control cabinet
 - The control cabinet must be conductive.
 - Ground the control cabinet with the thickest possible grounding cable.
 - To ensure that there is electric contact between the control cabinet and its door, connect the cabinet and its doors with thick wires.
 - In order to suppress the leakage of radio waves, the control cabinet structure must have minimal openings. Also, wrap the cable holes with a shielding cover or other shielding devices.
 - The gap between the control cabinet and its door must be as small as possible by attaching EMI gaskets between them.

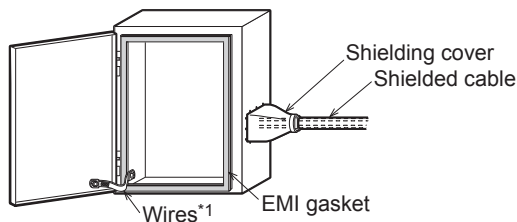

*1. These wires are used to improve the conductivity between the door and control cabinet.

- Caution for wiring
For noise prevention please attach at least 50 mm (1.97") of the twisted-pair cable along the grounding plate to which the ground terminal is connected.

→ For wiring details, refer to Section 4.2

Compliance with UKCA marking

The requirements for compliance with the UKCA marking are the same as those with the EC Directive (CE marking).

Location and Usage of Manual

The FX3U-32DP PROFIBUS-DP Interface Block is a DP-Slave for the PROFIBUS-DP network. By connecting the FX3U-32DP, the FX3G/FX3GC^{*1}/FX3U/FX3UC^{*1}/FX5U^{*2}/FX5UC^{*2} PLC can both read and write data from and to a DP-Master.

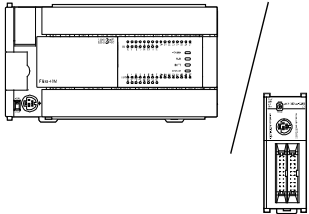
PLC	
 <p>FX3G/FX3GC^{*1}/FX3U/FX3UC^{*1}/ FX5U^{*2}/FX5UC^{*2} PLC</p>	<p>For installation and wiring</p> <ul style="list-style-type: none"> - Hardware Manual (Manual is supplied with product.) Supplied Manual - User's Manual - Hardware Edition Additional Manual <p>For basic/applied instructions and PLC devices</p> <ul style="list-style-type: none"> - Programming Manual - Basic & Applied Instruction Edition Additional Manual

*1. An FX2NC-CNV-IF or FX3UC-1PS-5V is necessary to connect to the 32DP with the FX3G/FX3UC Series PLC. However, the FX3U-32DP cannot be connected to FX3UC-32MT-LT(-2).

*2. An FX5-CNV-BUS or FX5-CNV-BUSC is necessary to connect to the 32DP with the FX5U/FX5UC PLC.

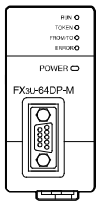

PROFIBUS-DP Master	
<p>If necessary, obtain the following manuals for your network.</p>	
 <p>FX3U-64DP-M</p>	<p>The installation manual is supplied with the product. For details, refer to the user's manual.</p> <p>For installation and wiring</p> <ul style="list-style-type: none"> - FX3U-64DP-M Installation Manual (Manual is supplied with product.) Supplied Manual <p>For details</p> <ul style="list-style-type: none"> - FX3U-64DP-M User's Manual Additional Manual
	<p>For other master modules Obtain the manual of another PROFIBUS-DP master module to fulfill its requirements for your network.</p>

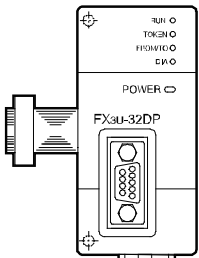

PROFIBUS-DP Slave	
 <p>FX3U-32DP</p>	<p>The hardware manual is supplied with the product. For details, refer to the user's manual.</p> <p>For installation and wiring</p> <ul style="list-style-type: none"> - Installation Manual (Manual is supplied with product.) Supplied Manual <p>For details</p> <ul style="list-style-type: none"> - User's Manual Additional Manual <p>This manual This manual details wiring, installation, specification and BFM allocation, etc.</p>

Associated Manuals

For a detailed explanation of the FX3U-32DP, refer to this manual.

For hardware information and instructions on the PLC main unit/CPU Module, other special function units/blocks, etc., refer to the appropriate manuals.

For acquiring required manuals, contact the distributor from where your product was purchased.

⊙ Indispensable manual

○ Manual that may be indispensable depending on the purpose of use

△ Abbreviated document

		Manual Name	Manual Number	Description	Model Code
Manual for the Main Unit/CPU Module					
FX3G/FX3GC/FX3U/FX3UC Series PLCs Main Unit					
△	Supplied Manual	FX3G Series Hardware Manual	JY997D46001	Describes FX3G Series PLC specification for I/O, wiring and installation extracted from the FX3G User's Manual - Hardware Edition. For details, refer to FX3G Series User's Manual - Hardware Edition.	-
○	Additional Manual	FX3G Series User's Manual - Hardware Edition	JY997D31301	Describes FX3G Series PLC specification details for I/O, wiring, installation and maintenance.	09R521
△	Supplied Manual	FX3GC Series Hardware Manual	JY997D45201	Describes FX3GC Series PLC specification for I/O, wiring and installation extracted from the FX3GC User's Manual - Hardware Edition. For details, refer to FX3GC Series User's Manual - Hardware Edition.	-
○	Additional Manual	FX3GC Series User's Manual - Hardware Edition	JY997D45401	Describes FX3GC Series PLC specification details for I/O, wiring, installation and maintenance.	09R533
△	Supplied Manual	FX3U Series Hardware Manual	JY997D50301	Describes FX3U Series PLC specification for I/O, wiring and installation extracted from the FX3U User's Manual - Hardware Edition. For details, refer to FX3U Series User's Manual - Hardware Edition.	-
○	Additional Manual	FX3U Series User's Manual - Hardware Edition	JY997D16501	Describes FX3U Series PLC specification details for I/O, wiring, installation and maintenance.	09R516
△	Supplied Manual	FX3UC (D, DS, DSS) Series Hardware Manual	JY997D50501	Describes FX3UC (D, DS, DSS) Series PLC specification for I/O, wiring and installation extracted from the FX3UC User's Manual - Hardware Edition. For details, refer to FX3UC Series User's Manual - Hardware Edition.	-
○	Additional Manual	FX3UC Series User's Manual - Hardware Edition	JY997D28701	Describes FX3UC Series PLC specification details for I/O, wiring, installation and maintenance.	09R519
FX5U/FX5UC PLCs CPU Module					
△	Supplied Manual	MELSEC iQ-F FX5U CPU Module Hardware Manual	JY997D53401	Describes FX5U PLC specification for I/O, wiring and installation extracted from the MELSEC iQ-F FX5U User's Manual (Hardware). For details, refer to MELSEC iQ-F FX5U User's Manual (Hardware).	-
○	Additional Manual	MELSEC iQ-F FX5U User's Manual (Hardware)	JY997D55301	Describes FX5U PLC specification details for I/O, wiring, installation and maintenance.	09R536

- ⊙ Indispensable manual
- Manual that may be indispensable depending on the purpose of use
- △ Abbreviated document

		Manual Name	Manual Number	Description	Model Code
△	Supplied Manual	MELSEC iQ-F FX5U CPU Module Hardware Manual	JY997D53401	Describes FX5U PLC specification for I/O, wiring and installation extracted from the MELSEC iQ-F FX5S/FX5UJ/FX5U/FX5UC User's Manual (Hardware). For details, refer to MELSEC iQ-F FX5S/FX5UJ/FX5U/FX5UC User's Manual (Hardware).	-
△	Supplied Manual	MELSEC iQ-F FX5UC CPU Module Hardware Manual	JY997D61001	Describes FX5UC PLC specification for I/O, wiring and installation extracted from the MELSEC iQ-F FX5S/FX5UJ/FX5U/FX5UC User's Manual (Hardware). For details, refer to MELSEC iQ-F FX5S/FX5UJ/FX5U/FX5UC User's Manual (Hardware).	-
○	Additional Manual	MELSEC iQ-F FX5S/FX5UJ/FX5U/FX5UC User's Manual (Hardware)	SH-082452ENG	Describes the details of hardware of the FX5 CPU module, including performance specifications, wiring, installation, and maintenance.	09R584
Programming					
○	Additional Manual	FX3S/FX3G/FX3GC/FX3U/FX3UC Series Programming Manual - Basic & Applied Instruction Edition	JY997D16601	Describes PLC programming for basic/applied instructions and devices.	09R517
○	Additional Manual	MELSEC-Q/L/F Structured Programming Manual (Fundamentals)	SH-080782	This manual contains explanations for the programming method, types of programming languages and other information required to create structured programs.	13JW06
○	Additional Manual	FX CPU Structured Programming Manual (Device & Common)	JY997D26001	This manual contains explanations for the devices and parameters provided in GX Works2 for structured programming.	09R925
○	Additional Manual	FX CPU Structured Programming Manual (Basic & Applied Instruction)	JY997D34701	This manual contains explanations for the sequence instructions provided in GX Works2 for structured programming.	09R926
○	Additional Manual	FX CPU Structured Programming Manual (Application Functions)	JY997D34801	This manual contains explanations for the application functions provided in GX Works2 for structured programming.	09R927
○	Additional Manual	MELSEC iQ-F FX5 Programming Manual (Program Design)	JY997D55701	Describes specifications of ladders, ST, FBD/LD, and other programs and labels.	09R538
○	Additional Manual	MELSEC iQ-F FX5 Programming Manual (Instructions, Standard Functions/Function Blocks)	JY997D55801	Describes specifications of instructions and functions that can be used in programs.	09R539
Manual for the PROFIBUS-DP Master Block, Interface Block					
PROFIBUS-DP Master Block					
△	Supplied Manual	FX3U-64DP-M Installation Manual	JY997D19901	Describes the FX3U-64DP-M PROFIBUS-DP Master Block specification for wiring and installation extracted from the FX3U-64DP-M User's Manual. For details, refer to FX3U-64DP-M User's Manual.	-

- ⊙ Indispensable manual
- Manual that may be indispensable depending on the purpose of use
- △ Abbreviated document

		Manual Name	Manual Number	Description	Model Code
○	Additional Manual	FX3U-64DP-M User's Manual	JY997D19201	Describes the FX3U-64DP-M PROFIBUS-DP Master Block specification details for wiring, installation and allocation BFM's, etc.	09R632
PROFIBUS-DP Interface Block					
△	Supplied Manual	FX3U-32DP Installation Manual	JY997D24901	Describes the FX3U-32DP PROFIBUS-DP Interface Block specification for wiring and installation extracted from the FX3U-32DP User's Manual. For details, refer to FX3U-32DP User's Manual.	-
⊙	Additional Manual	FX3U-32DP User's Manual	JY997D25201	Describes the FX3U-32DP PROFIBUS-DP Interface Block specification details for wiring, installation and allocation BFM's, etc.	09R633
○	Supplied Manual	FX0N-32NT-DP User's Manual	JY992D61401	Describes the FX0N-32NT-DP PROFIBUS-DP Interface Unit specification details for wiring, installation and allocation BFM's, etc.	-
PROFIBUS-DP Interface Block					
△	Supplied Manual	FX2N-32DP-IF Hardware Manual	JY992D77101	Describes the FX2N-32DP-IF PROFIBUS-DP Interface Unit specification for wiring and installation extracted from the FX2N-32DP-IF User's Manual. For details, refer to FX2N-32DP-IF User's Manual.	-
○	Additional Manual	FX2N-32DP-IF User's Manual	JY992D79401	Describes the FX2N-32DP-IF PROFIBUS-DP Interface Unit specification details for wiring, installation and allocation BFM's, etc.	-
Configuration Software					
⊙		GX Cofigurator-DP Configuration System for Open Networks Software Manual	-	Describes the operation details for the GX Cofigurator-DP Configuration System for Networks Software.	-

Generic Terms and Abbreviations

Generic Name and Abbreviation	Description
PLCs	
FX3G Series	Generic name of the FX3G Series
Main unit	Abbreviated name of the FX3G Series PLC main unit
FX3GC Series	Generic name of the FX3GC Series
Main unit	Abbreviated name of the FX3GC Series PLC main unit
FX3U Series	Generic name of the FX3U Series
Main unit	Abbreviated name of the FX3U Series PLC main unit
FX3UC Series	Generic name of the FX3UC Series
Main unit	Abbreviated name of the FX3UC Series PLC main unit
FX5U PLC	Generic name of the FX5U PLC
CPU module	Abbreviated name of the FX5U CPU module
FX5UC PLC	Generic name of the FX5UC PLC
CPU module	Abbreviated name of the FX5UC CPU module
FX2N Series	Generic name of the FX2N Series
FX0N Series	Generic name of the FX0N Series
Expansion board	Generic name of the FX3G/FX3U Series expansion board
Special adapter	Generic name of the FX3U Series special adapter
Special function units/block	Generic name of the FX0N/FX2N/FX3U Series FX3UC Series special function block, and FX2N Series special function unit
Extension unit/block	Generic name of I/O Extension block and powered extension unit
I/O Extension block	Generic name of FX2N Series extension block
Powered extension unit	Generic name of FX2N Series powered extension unit
PROFIBUS-DP Network	
PROFIBUS-DP network	Abbreviated name of the PROFIBUS-DP network
DP-Master	Generic name of the PROFIBUS-DP master module (include FX3U-64DP-M)
64DP-M	Abbreviated name of FX3U-64DP-M PROFIBUS-DP master block
DP-Slave	Generic name of the PROFIBUS-DP slave module
32DP	Abbreviated name of FX3U-32DP PROFIBUS-DP interface block
32DP-IF	Abbreviated name of FX2N-32DP-IF PROFIBUS-DP interface block
32NT-DP	Abbreviated name of FX0N-32NT-DP PROFIBUS-DP interface block
GX Configurator-DP	Generic name of configuration system for open networks software Version 7.00A or later.
Programming Tools	
Programming tool	Generic name of the programming software and handy programming panel
Programming software	Generic name of the following programming software GX Works2, GX Developer, GX IEC Developer, FX-PCS/WIN(-E)
GX Works2	Generic name of programming software packages SW□DNC-GXW2-J and SW□DNC-GXW2-E
GX Developer	Generic name of programming software packages SW□D5C-GPPW-J and SW□D5C-GPPW-E
GX IEC Developer	Generic name of programming software, GX IEC Developer Ver.7.00 or later
FX-PCS/WIN(-E)	Generic name of programming software packages FX-PCS/WIN and FX-PCS/WIN-E
Handy programming panel (HPP)	Generic name of the following models FX-30P, FX-10P(-E), FX-20P(-E)
RS-232/RS-422 conversion interface	Generic name of the following models FX-232AW, FX-232AWC, FX-232AWC-H

Generic Name and Abbreviation	Description
USB/RS-422 conversion interface	Abbreviated name of the FX-USB-AW USB/RS-422 Conversion Interface
Manuals	
Programming Manual	Generic name for FX3s/FX3G/FX3GC/FX3U/FX3UC Series Programming Manual - Basic & Applied Instruction Edition, MELSEC iQ-F FX5 Programming Manual (Program Design), and MELSEC iQ-F FX5 Programming Manual (Instructions, Standard Functions/Function Blocks)
FX3G PLC Hardware Edition	Abbreviated name of FX3G Series User's Manual - Hardware Edition
FX3GC Hardware Edition	Abbreviated name of FX3GC Series User's Manual - Hardware Edition
FX3U PLC Hardware Edition	Abbreviated name of FX3U Series User's Manual - Hardware Edition
FX3UC PLC Hardware Edition	Abbreviated name of FX3UC Series User's Manual - Hardware Edition
Analog Control Edition	Abbreviated name of FX3s/FX3G/FX3GC/FX3U/FX3UC Series User's Manual - Analog Control Edition
Positioning Control Edition	Abbreviated name of FX3s/FX3G/FX3GC/FX3U/FX3UC Series User's Manual - Positioning Control Edition
Data Communication Edition	Abbreviated name of FX Series User's Manual - Data Communication Edition
GX Configurator-DP Software Manual	Abbreviated name of GX Cofigurator-DP Configuration System for Open Networks Software Manual

Reading of the Manual

Shows the manual title.

This area shows the manual title for the page currently opened.

Shows the title of the chapter and the title of the section.

This area shows the title of the chapter and the title of the section for the page currently opened.

Indexes the chapter number.

The right side of each page indexes the chapter number for the page currently opened.

FX3u-32DP PROFIBUS-DP Interface Block
User's Manual
3 Installation
3.2 Mounting

3.2 Mounting

The 32DP can be mounted on a DIN rail (DIN46227) or mounted directly to the mounting surface with screws.

3.2.1 Direct Mounting

The 32DP can be directly mounted with M4 screws.
The 32DP mounting hole pitches are shown below.

→ For the connecting procedure to the extension port of the FX3a Series PLC, refer to FX3a PLC Hardware Edition
 → For the connecting procedure to the extension port of the FX3gc Series PLC, refer to FX3gc PLC Hardware Edition
 → For the connecting procedure to the extension port of the FX3u Series PLC, refer to FX3u PLC Hardware Edition
 → For the connecting procedure to the extension port of the FX3uc Series PLC, refer to FX3uc PLC Hardware Edition
 → For the connecting procedure to the extension port of the FX5U PLC, refer to MELSEC iQ-F FX5U User's Manual (Hardware)
 → For the connecting procedure to the extension port of the FX5UC PLC, refer to MELSEC iQ-F FX5UC User's Manual (Hardware)

Note

- Mounting screw: M4 screw.
- An interval space between each unit of 1 to 2 mm (0.04" to 0.08") is necessary.
- When connecting the 32DP to an extension unit/block (or special function unit/block), first mount the extension unit/block (or special function unit/block) to the right side of the PLC.

Direct Mounting

- 1) Drill screw holes on the mounting surface according to the diagram above.
- 2) Align the 32DP (right fig. A) with the holes and tighten with M4 screws (right fig. B).

- 3) Connect the 32DP's extension cable (right fig. C) to the extension device connector of the main unit.
 → For extension cable connection procedures of the FX3a Series PLC, refer to FX3a PLC Hardware Edition
 → For extension cable connection procedures of the FX3gc Series PLC, refer to FX3gc PLC Hardware Edition
 → For extension cable connection procedures of the FX3u Series PLC, refer to FX3u PLC Hardware Edition
 → For extension cable connection procedures of the FX3uc Series PLC, refer to FX3uc PLC Hardware Edition
 → For extension cable connection procedures of the FX5U PLC, refer to MELSEC iQ-F FX5U User's Manual (Hardware)
 → For extension cable connection procedures of the FX5UC PLC, refer to MELSEC iQ-F FX5UC User's Manual (Hardware)

1 Introduction

2 Specifications

3 Installation

4 Wiring

5 Terminals on PROFIBUS-DP Network

6 Buffer Memory Allocation

7 Parameter Setting and Network Configuration

8 Example Program

9 Diagnostics

25

Shows the reference.

The mark of " → " is expressing the reference destination and the reference manual.

The page above is an example. It may differ from the actual page.

1. Introduction

1.1 Product Outline and Features

The FX3U-32DP PROFIBUS-DP Interface Block (hereinafter called 32DP) enables users to integrate the MELSEC FX3G/FX3GC⁺/FX3U/FX3UC⁺/FX5U⁺/FX5UC⁺ PLC in any existing PROFIBUS-DP network (DP-V0/DP-V1) as a DP-Slave. The 32DP links the FX3G/FX3GC⁺/FX3U/FX3UC⁺/FX5U⁺/FX5UC⁺ PLC with PROFIBUS-DP decentralized control tasks. The module connects the PLC system to the DP-Master in the PROFIBUS-DP network for efficient and easy data exchange.

- *1. An FX2NC-CNV-IF or FX3UC-1PS-5V is necessary to connect to the 32DP with the FX3GC/FX3UC Series PLC.
However, the 32DP cannot be connected to the FX3UC-32MT-LT(-2).
- *2. An FX5-CNV-BUS or FX5-CNV-BUSC is necessary to connect to the 32DP with the FX5U/FX5UC PLC.

1. Easy Connectivity to an existing PROFIBUS-DP Network

The 32DP Interface Module enables the FX3G/FX3GC⁺/FX3U/FX3UC⁺/FX5U⁺/FX5UC⁺ PLC to fit into an existing PROFIBUS-DP Network as a DP-Slave, while reducing the time and cost for users to build up a new network system.

→ For the PROFIBUS-DP Network configuration, refer to Subsection 1.3.1

- *1. An FX2NC-CNV-IF or FX3UC-1PS-5V is necessary to connect to the 32DP with the FX3GC/FX3UC Series PLC.
However, the 32DP cannot be connected to the FX3UC-32MT-LT(-2).
- *2. An FX5-CNV-BUS or FX5-CNV-BUSC is necessary to connect to the 32DP with the FX5U/FX5UC PLC.

2. Enhanced Data Exchange

The 32DP has enhanced the data exchange functionality in the following communication formats.

→ For details, refer to Chapter 5 and 6

- Cyclic Input/Output Data Communication - a maximum of 144 Bytes
- Acyclic Input/Output Data Communication - a maximum of 140 Bytes
- User-Diagnostic Messages
- Alarm(Status) Messages

3. Global Control

The 32DP supports SYNC / UNSYNC / FREEZE / UNFREEZE global controls.

→ For details, refer to Chapter 5

4. Flexible and Easy Network Setting

The 32DP enables a flexible and smooth integration with components on a new/existing PROFIBUS-DP Network. The FX3U-32DP PROFIBUS Interface Block is fully applicable for the user-specific PROFIBUS-DP Network.

→ For details, refer to Chapter 7 and 8

5. Various Transmission Speed Options

The 32DP supports the communication speeds, 9.6k, 19.2k, 45.45k, 93.75k, 187.5k, 500k, 1.5M, 3M, 6M and 12Mbps to fit into various kinds of networks. To connect the 32DP to a PROFIBUS-DP Network, use the standard 9-pin D-SUB connector and shielded twisted-pair PROFIBUS cable complying with EN50170.

→ For wiring, refer to Chapter 4

→ For the transmission speed parameter, refer to Section 2.3 and 6.7

Note : INPUT/OUTPUT to where?

When this manual references INPUT/OUTPUT for communication data on the PROFIBUS-DP network, it refers to data from the DP-Master's point of view. Therefore, CYCLIC INPUT DATA means THE CYCLIC DATA STREAMING FROM DP-SLAVE TO DP-MASTER. On the other hand, ACYCLIC OUTPUT DATA, for example, means THE ACYCLIC DATA STREAMING FROM DP-MASTER TO DP-SLAVE.

1.2 External Dimensions

1.2.1 External Dimensions and Part Names

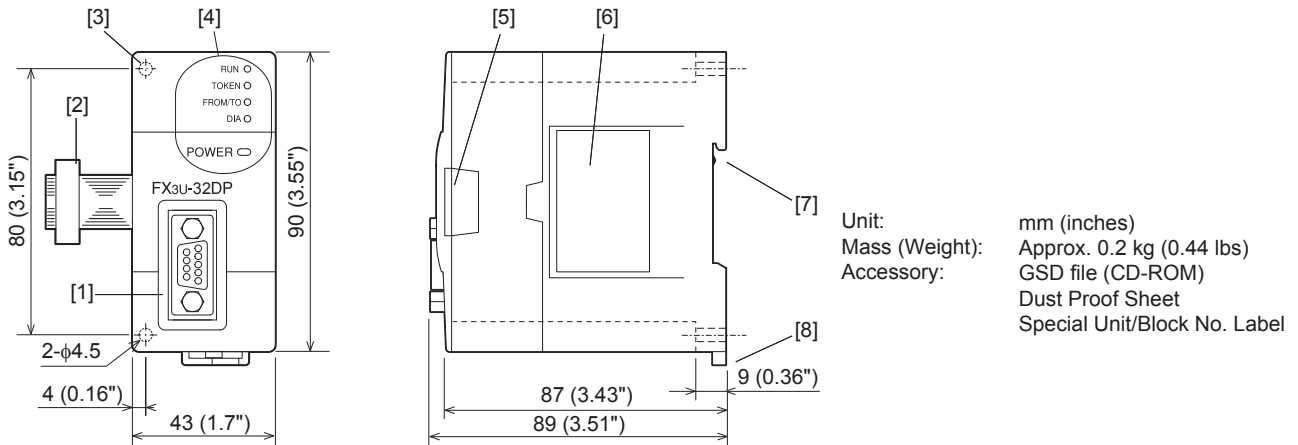

- [1] PROFIBUS-DP port (9-pin D-SUB Connector: #4-40 UNC inch screw thread)
- [2] Extension cable
- [3] Direct mounting hole: 2- ϕ 4.5 (0.18"), mounting screw: M4 screw
- [4] Status LEDs

→ For details on the status LEDs, refer to Section 9.1

LED Name	Color	Description
POWER	Green	ON : The connected PLC supplies power to the 32DP correctly OFF : Power is being supplied incorrectly from the PLC to the 32DP due to an unsecured cable connection
FROM/TO	Green	ON: Constant FROM/TO access within 200ms intervals OFF : No FROM/TO access within 200ms
RUN	Green	ON : In cyclic data exchange mode OFF : Not in cyclic data exchange mode Flashing : The DP-Master is in clear mode or the 32DP is in fail-safe mode
DIA	Red	ON : Hardware error in the 32DP OFF: Normal Operation without errors Flashing : A user-diagnostic message or a DP-V1 Alarm/Status message is left unread
TOKEN	Green	ON: The 32DP has established a connection with the DP-Master at an appropriate baud rate A Class2 Master can access the 32DP now OFF: The 32DP has not established a connection at any baud rate

- [5] Extension port under the top cover
- [6] Name plate
- [7] DIN rail mounting groove (DIN rail: DIN46277 35 mm (1.38") wide)
- [8] DIN rail mounting hook

1.2.2 PROFIBUS-DP Connector Pin Assignment

The PROFIBUS-DP connector is a 9-pin D-SUB type, with the following pin assignment.

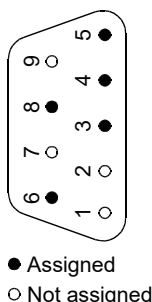

Pin No.	Signal Name	Description
3	RXD/TXD-P	Receive/Transmit-Data-P
4	RTS	Ready to send
5	DGND	Data Ground
6	VP	Voltage-Plus
8	RXD/TXD-N	Receive/Transmit-Data-N
1, 2, 7, 9	NC	Not assigned

1.3 Network Configuration

1.3.1 Applicable PROFIBUS-DP Network

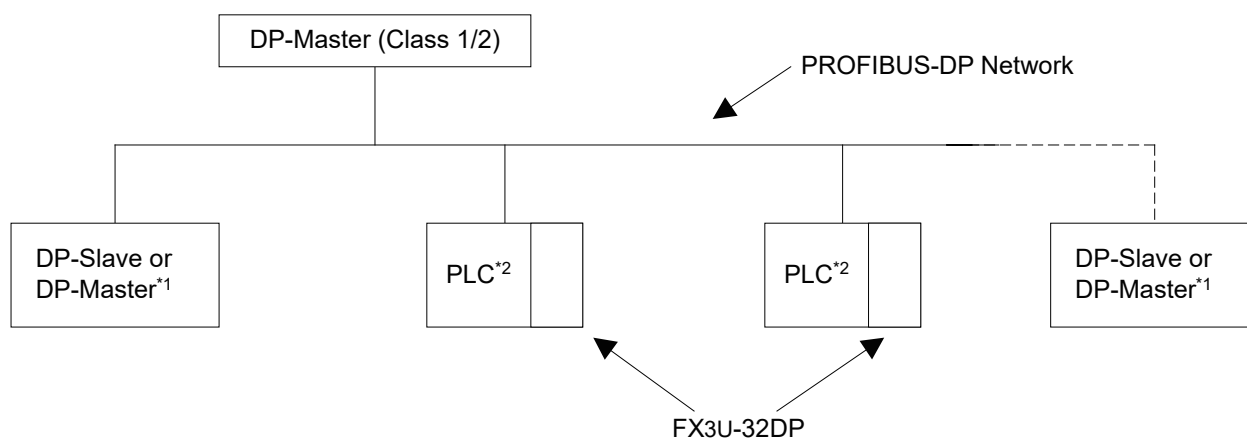

- *1. To prevent signal reflection, place a self-terminating DP connector/device at each end of the PROFIBUS-DP Network.
- *2. FX3G/FX3GC^{*3}/FX3U/FX3UC^{*3}/FX5U^{*4}/FX5UC^{*4} PLC.
- *3. An FX2NC-CNV-IF or FX3UC-1PS-5V is necessary to connect to the 32DP with the FX3GC/FX3UC Series PLC.
However, the 32DP cannot be connected to the FX3UC-32MT-LT(-2).
- *4. An FX5-CNV-BUS or FX5-CNV-BUSC is necessary to connect to the 32DP with the FX5U/FX5UC PLC.

Note

The FX3U-32DP is not self-terminated.

1.3.2 Applicable PLC

The FX3U-32DP functions with an FX3G/FX3GC^{*1}/FX3U/FX3UC^{*1}/FX5U^{*2}/FX5UC^{*2} PLC. To set up the 32DP with an FX3G/FX3GC^{*1}/FX3U/FX3UC^{*1}/FX5U^{*2}/FX5UC^{*2} PLC, connect the 32DP's extension cable to the PLC's extension port.

The 32DP occupies 8 points on either input or output of the PLC extension bus. The FX3U/FX3UC^{*1}/FX5U^{*2}/FX5UC^{*2} PLC has a maximum of 256 controllable I/O points, whereas the maximum connectable special function blocks for a single FX3U/FX3UC^{*1}/FX5U^{*2}/FX5UC^{*2} PLC is 8 units. The FX3G/FX3GC^{*1} Series PLC has a maximum of 128 controllable I/O points, whereas the maximum connectable special function blocks for a single FX3G/FX3GC^{*1} PLC is 8 units.

PLC Type	Version
FX3G Series PLC	Ver. 1.00 or later
FX3GC ^{*1} Series PLC	Ver. 1.40 or later
FX3U Series PLC	Ver. 2.21 or later
FX3UC ^{*1} Series PLC	Ver. 2.21 or later
FX5U PLC ^{*2}	Ver. 1.014 or later
FX5UC PLC ^{*2}	Ver. 1.014 or later

- *1. An FX2NC-CNV-IF or FX3UC-1PS-5V is necessary to connect to the 32DP with the FX3GC/FX3UC Series PLC.
However, the 32DP cannot be connected to the FX3UC-32MT-LT(-2).
- *2. An FX5-CNV-BUS or FX5-CNV-BUSC is necessary to connect to the 32DP with the FX5U/FX5UC PLC.

1.4 FROM/TO Execution Time

The PROFIBUS cycle time and FROM/TO instruction operates asynchronously. If data is written to the 32DP in the PROFIBUS cycle time, this data will move to the system area on the next PROFIBUS cycle time.

Reference

The FROM/TO Execution Time varies as follows, depending on the data amount to be transferred.

FROM/TO Execution Time details

1) FX3U/FX3UC Series PLC

The following table is also applicable to the other instructions accessing the 32DP BFM's from FX3U/FX3UC Series PLC.

FNC No.	Instruction	Execution time in ON status (μs)		Execution time in OFF status (μs)		Note
		16-bit instruction	32-bit instruction	16-bit instruction	32-bit instruction	
FX3U-32DP						
78	FROM	15 + 250n	15 + 320n	0.585	1.105	BFM#100 to #171
79	TO	15 + 280n	15 + 415n	0.585	1.105	BFM#300 to #371

n: The number of transferred data

2) FX3G/FX3GC Series PLC

FNC No.	Instruction	Standard mode				Extension mode				Note
		Execution time in ON status (μs)		Execution time in OFF status (μs)		Execution time in ON status (μs)		Execution time in OFF status (μs)		
		16-bit instruction	32-bit instruction	16-bit instruction	32-bit instruction	16-bit instruction	32-bit instruction	16-bit instruction	32-bit instruction	
FX3U-32DP										
78	FROM	20 + 225n	25 + 295n	0.61	0.61	25 + 225n	25 + 295n	0.8	0.8	BFM#100 to #171
79	TO	20 + 290n	25 + 420n	0.61	0.61	25 + 290n	30 + 420n	0.8	0.8	BFM#300 to #371

n: The number of transferred data

Note

- The execution times above are approximate values for the FX3U-32DP.
- The FROM/TO Execution Time varies depending on each special function block.
- It is not necessary to check all DP-Slaves' cyclic I/O data in a single PROFIBUS Cycle Time.

1.5 System Start-up Procedure

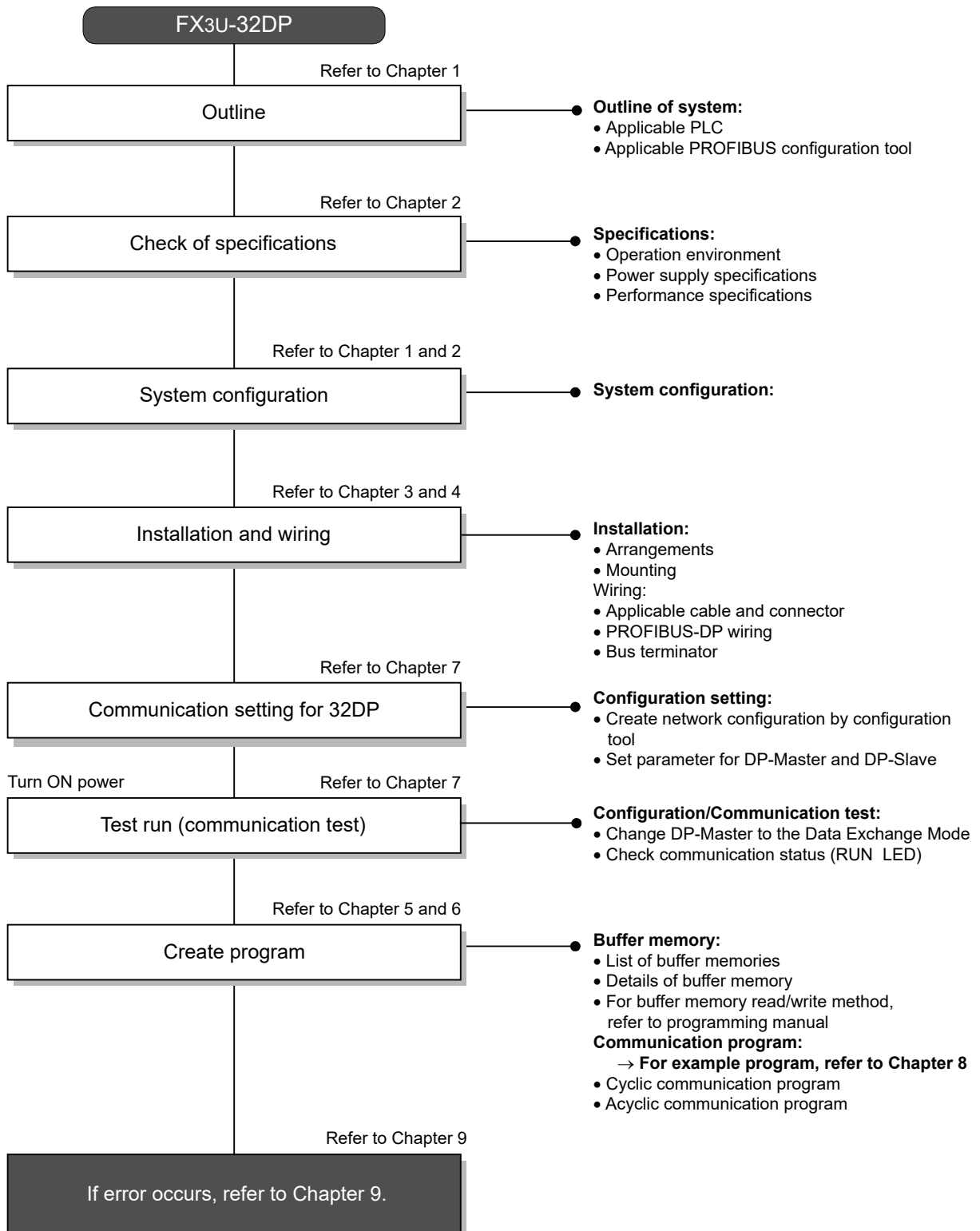

2. Specifications

DESIGN PRECAUTIONS



WARNING

- Make sure to have the following safety circuits outside of the PLC to ensure safe system operation even during external power supply problems or PLC failure.
Otherwise, malfunctions may cause serious accidents.
 - 1) Most importantly, have the following: an emergency stop circuit, a protection circuit, an interlock circuit for opposite movements (such as normal vs. reverse rotation), and an interlock circuit (to prevent damage to the equipment at the upper and lower positioning limits).
 - 2) Note that when the PLC CPU detects an error, such as a watchdog timer error, during self-diagnosis, all outputs are turned off. Also, when an error that cannot be detected by the PLC CPU occurs in an input/output control block, output control may be disabled.
External circuits and mechanisms should be designed to ensure safe machinery operation in such a case.
 - 3) Note that when an error occurs in a relay, triac or transistor output device, the output could be held either on or off.
For output signals that may lead to serious accidents, external circuits and mechanisms should be designed to ensure safe machinery operation in such a case.

DESIGN PRECAUTIONS



CAUTION

- Make sure to observe the following precautions in order to prevent any damage to the machinery or accidents due to abnormal data written to the PLC under the influence of noise:
 - 1) Do not bundle the main circuit line together with or lay it close to the main circuit, high-voltage line, or load line. Otherwise, noise disturbance and/or surge induction are likely to take place. As a guideline, lay the control line at least 100mm (3.94") or more away from the main circuit, high-voltage line, or load line.
 - 2) Ground the shield wire or shield of the shielded cable at one point on the PLC. However, do not ground them at the same point as the high-voltage lines.
- Install module so that excessive force will not be applied to peripheral device connectors.
Failure to do so may result in wire damage/breakage or PLC failure.

STARTUP AND MAINTENANCE PRECAUTIONS



WARNING

- Do not touch any terminal while the PLC's power is on.
Doing so may cause electric shock or malfunctions.
- Before cleaning or retightening terminals, externally cut off all phases of the power supply.
Failure to do so may cause electric shock.
- Before modifying or disrupting the program in operation or running the PLC, carefully read through this manual and the associated manuals and ensure the safety of the operation.
An operation error may damage the machinery or cause accidents.

STARTUP AND MAINTENANCE PRECAUTIONS



CAUTION

- Do not disassemble or modify the unit.
Doing so may cause fire, equipment failures, or malfunctions.
* For repair, contact your local Mitsubishi Electric representative.
- Do not drop the product or expose the product to strong impacts, as doing so may cause product damage.
- Turn off the power to the PLC before attaching or detaching the peripheral devices.
Failure to do so may cause equipment failures or malfunctions.

DISPOSAL PRECAUTIONS



- Please contact a certified electronic waste disposal company for the environmentally safe recycling and disposal process for your device.

TRANSPORTATION AND STORAGE PRECAUTIONS



- The PLC is a precision instrument. During transportation, avoid impacts larger than those specified in the general specifications of the PLC main unit manual by using dedicated packaging boxes and shock-absorbing pallettes. Failure to do so may cause failures in the PLC.
After transportation, verify operation of the PLC and check for damage of the mounting part, etc.

2.1 General Specifications

The FX3G/FX3GC^{*1}/FX3U/FX3UC^{*1}/FX5U^{*2}/FX5UC^{*2} PLC's general specifications except the following items are applicable to the 32DP specifications. However, do not perform any dielectric withstand voltage tests or insulation resistance tests on this product.

- Refer to FX3G PLC Hardware Edition
- Refer to FX3GC PLC Hardware Edition
- Refer to FX3U PLC Hardware Edition
- Refer to FX3UC PLC Hardware Edition

→ Refer to MELSEC iQ-F FX5S/FX5UJ/FX5U/FX5UC User's Manual (Hardware)

Item	Specifications	
Withstand voltage	500 V AC for 1 min	Between communication connector frame and ground terminal of PLC main unit
Insulation resistance	5 MΩ or more by 500 V DC Insulation tester	

- *1. An FX2NC-CNV-IF or FX3UC-1PS-5V is necessary to connect to the 32DP with the FX3GC/FX3UC Series PLC.
However, the 32DP cannot be connected to the FX3UC-32MT-LT(-2).
- *2. An FX5-CNV-BUS or FX5-CNV-BUSC is necessary to connect to the 32DP with the FX5U/FX5UC PLC.

2.2 Power Supply Specifications

Items	Description
Internal Power Supply	145 mA at 24V DC is supplied from the internal service power in the main unit via extension cable

1

Introduction

2

Specifications

3

Installation

4

Wiring

5

Comm. Outline on PROFIBUS-DP Network

6

Buffer Memory Allocation

7

Parameter Setting and Network Configuration

8

Example Program

9

Diagnostics

2.3 Performance Specifications

Item		Specifications	
Transmission Type		Bus network	
Unit Type		PROFIBUS-DP Slave	
Maximum Transmission Data		144 Byte (default: 32Byte Input / 32Byte Output cyclic)	
Maximum Number of FX3U-32DP at one PLC		8 units	
Supported Transmission Speed (bps) and Bus Length	9.6k, 19.2k, 45.45k, 93.75k	1,200 m (3,937') / segment	→ Refer to the note below
	187.5k	1,000 m (3,281') / segment	
	500k	400 m (1,312') / segment	
	1.5 M	200 m (656') / segment	
	3M, 6M, 12M	100 m (328') / segment	
PROFIBUS Module ID		"F332" hex	
Connector	PROFIBUS-DP Network	Port for PROFIBUS-DP network (9 pin D-SUB Connector)	
Global Control		Supports SYNC, UNSYNC, FREEZE, and UNFREEZE modes	
Terminal Resistor		Not built in.	
Number of occupied I/O points		Occupies 8 points on either input or output of PLC extension bus	
Applicable PLC		FX3G/FX3GC ^{*1} /FX3U/FX3UC ^{*1} /FX5U ^{*2} /FX5UC ^{*2} PLC	
LED ^{*3}	POWER	ON : The connected PLC supplies power to the 32DP correctly	
	FROM/TO	ON : Constant FROM/TO access within 200ms intervals	
	RUN	ON : In cyclic data exchange mode Flashing : The DP-Master is in clear mode, or the 32DP is in fail-safe mode	
	DIA	ON : Hardware error in the 32DP Flashing : A User-Diagnostic message or a DP-V1 Alarm/Status message is left unread	
	TOKEN	ON : Connected properly with the DP-Master at an appropriate baud rate	

- *1. An FX2NC-CNV-IF or FX3UC-1PS-5V is necessary to connect to the 32DP with the FX3GC/FX3UC Series PLC.
However, the 32DP cannot be connected to the FX3UC-32MT-LT(-2).
- *2. An FX5-CNV-BUS or FX5-CNV-BUSC is necessary to connect to the 32DP with the FX5U/FX5UC PLC.
- *3. The LEDs on the front panel show the 32DP's operation status.
→ For the LED details, refer to Section 9.1

Note

The following table shows the acceptable bus length.

Maximum Bus Length = (The number of repeaters + 1) × (Bus Length / segment)

Transmission Speed (bps)	Maximum Bus Length			
	No repeater	1 repeater	2 repeaters	3 repeaters
9.6k, 19.2k, 45.45k, 93.75k	1,200 m (3,937')	2,400 m (7,874')	3,600 m (11,811')	4,800 m (15,748')
187.5k	1,000 m (3,281')	2,000 m (6,562')	3,000 (9,843')	4,000 m (13,123')
500k	400 m (1,312')	800 m (2,625')	1,200 m (3,937')	1,600 m (5,249')
1.5 M	200 m (656')	400 m (1,312')	600 m (1,969')	800 m (2,625')
3M, 6M, 12M	100 m (328')	200 m (656')	300 m (984')	400 m (1,312')

3. Installation

DESIGN PRECAUTIONS



WARNING

- Make sure to have the following safety circuits outside of the PLC to ensure safe system operation even during external power supply problems or PLC failure. Otherwise, malfunctions may cause serious accidents.
 - 1) Most importantly, have the following: an emergency stop circuit, a protection circuit, an interlock circuit for opposite movements (such as normal vs. reverse rotation), and an interlock circuit (to prevent damage to the equipment at the upper and lower positioning limits).
 - 2) Note that when the PLC CPU detects an error, such as a watchdog timer error, during self-diagnosis, all outputs are turned off. Also, when an error that cannot be detected by the PLC CPU occurs in an input/output control block, output control may be disabled. External circuits and mechanisms should be designed to ensure safe machinery operation in such a case.
 - 3) Note that when an error occurs in a relay, triac or transistor output device, the output could be held either on or off. For output signals that may lead to serious accidents, external circuits and mechanisms should be designed to ensure safe machinery operation in such a case.

DESIGN PRECAUTIONS



CAUTION

- Make sure to observe the following precautions in order to prevent any damage to the machinery or accidents due to abnormal data written to the PLC under the influence of noise:
 - 1) Do not bundle the main circuit line together with or lay it close to the main circuit, high-voltage line, or load line. Otherwise, noise disturbance and/or surge induction are likely to take place. As a guideline, lay the control line at least 100mm (3.94") or more away from the main circuit, high-voltage line, or load line.
 - 2) Ground the shield wire or shield of the shielded cable at one point on the PLC. However, do not ground them at the same point as the high-voltage lines.
- Install module so that excessive force will not be applied to peripheral device connectors. Failure to do so may result in wire damage/breakage or PLC failure.

INSTALLATION PRECAUTIONS



WARNING

- Make sure to cut off all phases of the power supply externally before attempting installation or wiring work. Failure to do so may cause electric shock.

INSTALLATION PRECAUTIONS



CAUTION

- Use the product within the generic environment specifications described in the PLC main unit manual (Hardware Edition). Never use the product in areas with dust, oily smoke, conductive dusts, corrosive gas (salt air, Cl₂, H₂S, SO₂, or NO₂), flammable gas, vibration or impacts, or exposed to high temperature, condensation, or wind and rain. If the product is used in such conditions, electric shock, fire, malfunction, deterioration or damage may occur.
- Install the product securely using a DIN rail or mounting screws.
- Install the product on a flat surface. If the mounting surface is rough, undue force will be applied to the PC board, thereby causing nonconformities.
- When drilling screw holes or wiring, make sure cutting or wire debris does not enter the ventilation slits. Failure to do so may cause fire, equipment failures or malfunctions.
- Be sure to remove the dust proof sheet from the PLC's ventilation port when the installation work is completed. Failure to do so may cause fires, equipment failures, and malfunctions.
- Connect the extension and communication cables securely to their designated connectors. Unsecured connection may cause malfunctions.
- Do not touch the conductive parts of the product directly to avoid failure or malfunction.

1

Introduction

2

Specifications

3

Installation

4

Wiring

5

Comm. Outline on PROFIBUS-DP Network

6

Buffer Memory Allocation

7

Parameter Setting and Network Configuration

8

Example Program

9

Diagnostics

3.1 Installation Arrangements

The 32DP is connected to the extension port of an FX3G/FX3GC^{*1}/FX3U/FX3UC^{*1}/FX5U^{*2}/FX5UC^{*2} PLC or extension unit/block (including special function unit/block) on the right side.

Since additional extension devices can be added on both the left and right-hand sides of the PLC, keep an appropriate amount of space on both sides of the PLC when planning to add extension devices in the future. For further details on installation arrangements, refer to the following manual.

→ **FX3G PLC Hardware Edition**

→ **FX3GC PLC Hardware Edition**

→ **FX3U PLC Hardware Edition**

→ **FX3UC PLC Hardware Edition**

→ **MELSEC iQ-F FX5S/FX5UJ/FX5U/FX5UC User's Manual (Hardware)**

*1. An FX2NC-CNV-IF or FX3UC-1PS-5V is necessary to connect to the 32DP with the FX3GC/FX3UC Series PLC.
However, the 32DP cannot be connected to the FX3UC-32MT-LT(-2).

*2. An FX5-CNV-BUS or FX5-CNV-BUSC is necessary to connect to the 32DP with the FX5U/FX5UC PLC.

Note

- Keep a space of 50 mm (1.97") or more between the 32DP and the other devices and cabinet. Install the unit as far from high-voltage lines, high-voltage devices and power equipment as possible.

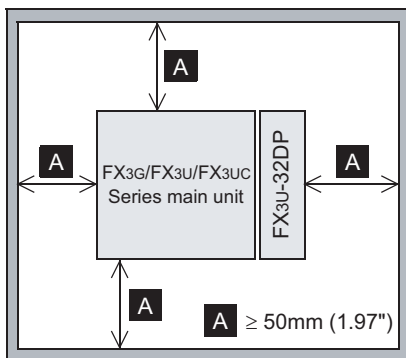

- To prevent the product's temperature from rising, do not install the PLC on a floor, ceiling, or in the vertical direction. Install it horizontally on a wall as shown below.

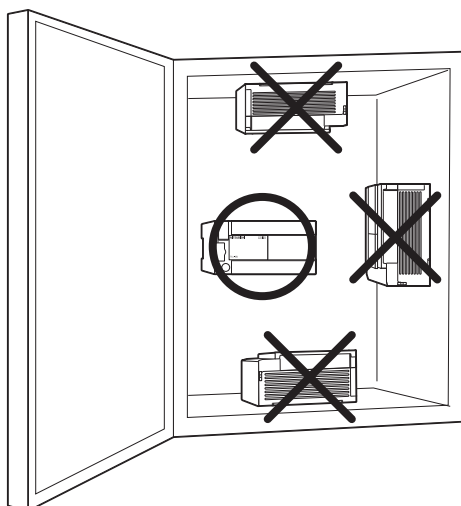

- Take care to position the 32DP and other peripheral devices for their extension ports and cables to be as close to each other as possible.

3.2 Mounting

The 32DP can be mounted on a DIN rail (DIN46227) or mounted directly to the mounting surface with screws.

3.2.1 Direct Mounting

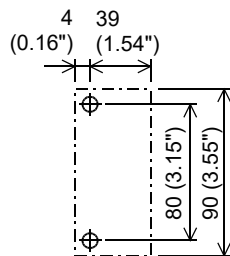

The 32DP can be directly mounted with M4 screws.
The 32DP mounting hole pitches are shown below.

- For the connecting procedure to the extension port of the FX3G Series PLC, refer to FX3G PLC Hardware Edition
- For the connecting procedure to the extension port of the FX3Gc Series PLC, refer to FX3Gc PLC Hardware Edition
- For the connecting procedure to the extension port of the FX3U Series PLC, refer to FX3U PLC Hardware Edition
- For the connecting procedure to the extension port of the FX3UC Series PLC, refer to FX3UC PLC Hardware Edition
- For the connecting procedure to the extension port of the FX5U PLC and FX5UC PLC, refer to MELSEC iQ-F FX5S/FX5UJ/FX5U/FX5UC User's Manual (Hardware)

Note

- Mounting screw: M4 screw.
- An interval space between each unit of 1 to 2 mm (0.04" to 0.08") is necessary.
- When connecting the 32DP to an extension unit/block (or special function unit/block), first mount the extension unit/block (or special function unit/block) to the right side of the PLC.

Direct Mounting

- 1) Drill screw holes on the mounting surface according to the diagram above.
- 2) Align the 32DP (right fig. A) with the holes and tighten with M4 screws (right fig. B).

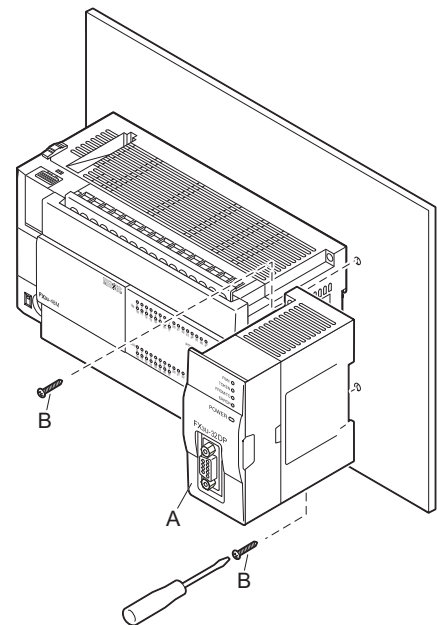

- 3) Connect the 32DP's extension cable (right fig. C) to the extension device connector of the main unit.
 - For extension cable connection procedures of the FX3G Series PLC, refer to FX3G PLC Hardware Edition
 - For extension cable connection procedures of the FX3Gc Series PLC, refer to FX3Gc PLC Hardware Edition
 - For extension cable connection procedures of the FX3U Series PLC, refer to FX3U PLC Hardware Edition
 - For extension cable connection procedures of the FX3UC Series PLC, refer to FX3UC PLC Hardware Edition
 - For extension cable connection procedures of the FX5U PLC and FX5UC PLC, refer to MELSEC iQ-F FX5S/FX5UJ/FX5U/FX5UC User's Manual (Hardware)

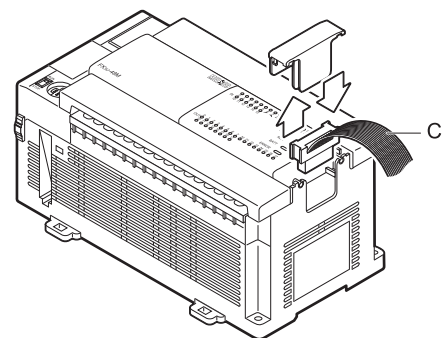

1

Introduction

2

Specifications

3

Installation

4

Wiring

5

Comm. Outline on PROFIBUS-DP Network

6

Buffer Memory Allocation

7

Parameter Setting and Network Configuration

8

Example Program

9

Diagnostics

3.2.2 DIN Rail Mounting

The 32DP can be mounted on a DIN rail (DIN46227, 35mm width).

- For detail, refer to FX3G PLC Hardware Edition
- For detail, refer to FX3GC PLC Hardware Edition
- For detail, refer to FX3U PLC Hardware Edition
- For detail, refer to FX3UC PLC Hardware Edition

→ For detail, refer to MELSEC iQ-F FX5S/FX5UJ/FX5U/FX5UC User's Manual (Hardware)

Note

- An interval space between each unit of 1 to 2 mm (0.04" to 0.08") is necessary.
- When connecting the 32DP to an extension unit/block (or special function unit/block), first mount the extension unit/block (or special function unit/block) to the right side of the PLC.

DIN Rail Mounting

- 1) Fit the upper edge of the DIN rail mounting groove (right fig. A) onto the DIN rail.
- 2) Push the product onto the DIN rail.

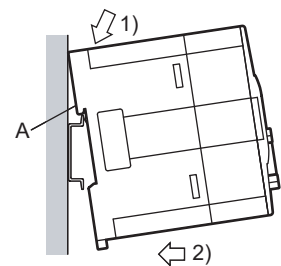

- 3) Connect the 32DP's extension cable (right fig. B) to the extension device connector of the main unit.

- For extension cable connection procedures of the FX3G Series PLC, refer to FX3G PLC Hardware Edition
- For extension cable connection procedures of the FX3GC Series PLC, refer to FX3GC PLC Hardware Edition
- For extension cable connection procedures of the FX3U Series PLC, refer to FX3U PLC Hardware Edition
- For extension cable connection procedures of the FX3UC Series PLC, refer to FX3UC PLC Hardware Edition
- For extension cable connection procedures of the FX5U PLC and FX5UC PLC, refer to MELSEC iQ-F FX5S/FX5UJ/FX5U/FX5UC User's Manual (Hardware)

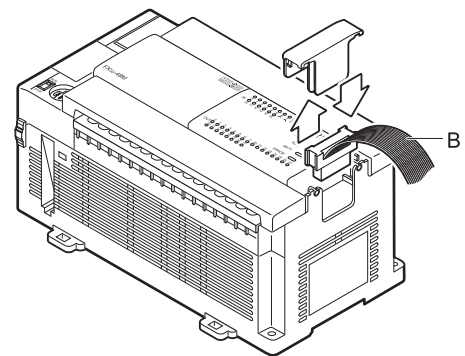

Removing from DIN Rail

- 1) Disconnect the PROFIBUS-DP communication cable and extension cables.
- 2) Insert the tip of a flathead screwdriver into the hole of the DIN rail mounting hook (right fig. A).
- 3) Move the flathead screwdriver as shown in the figure to the right, pull out the DIN rail mounting hook (right fig. A).
- 4) Remove the product from the DIN rail (right fig. B).

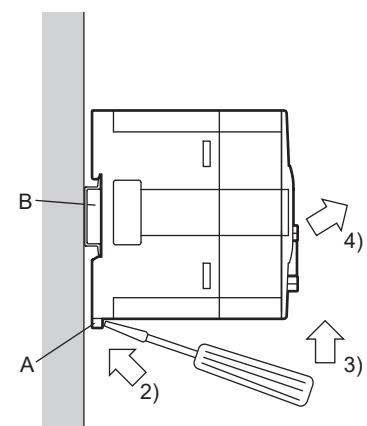

4. Wiring

DESIGN PRECAUTIONS



CAUTION

- Make sure to observe the following precautions in order to prevent any damage to the machinery or accidents due to abnormal data written to the PLC under the influence of noise:
 - 1) Do not bundle the main circuit line together with or lay it close to the main circuit, high-voltage line, or load line. Otherwise, noise disturbance and/or surge induction are likely to take place. As a guideline, lay the control line at least 100mm (3.94") or more away from the main circuit, high-voltage line, or load line.
 - 2) Ground the shield wire or shield of the shielded cable at one point on the PLC. However, do not ground them at the same point as the high-voltage lines.
- Install module so that excessive force will not be applied to peripheral device connectors. Failure to do so may result in wire damage/breakage or PLC failure.

WIRING PRECAUTIONS



WARNING

- Cut off all phases of the power supply externally before installation or wiring work in order to avoid damage to the product or electric shock.

WIRING PRECAUTIONS



CAUTION

- When drilling screw holes or wiring, make sure cutting or wire debris does not enter the ventilation slits. Failure to do so may cause fire, equipment failures or malfunctions.

4.1 Applicable Cable and Connector

The following table shows the applicable cable and connector for a PROFIBUS-DP network.

Item	Description
PROFIBUS-DP network cable	Shielded twisted-pair PROFIBUS cable complying with EN50170
Connector	Applicable only to PROFIBUS connector (9-pin D-SUB Connector: #4-40 UNC inch screw thread) → For PROFIBUS connectors, refer to the respective PROFIBUS connector manual

1

Introduction

2

Specifications

3

Installation

4

Wiring

5

Comm. Outline on PROFIBUS-DP Network

6

Buffer Memory Allocation

7

Parameter Setting and Network Configuration

8

Example Program

9

Diagnostics

4.2 PROFIBUS-DP Wiring

To connect the 32DP to a PROFIBUS-DP network, use the PROFIBUS connector and shielded twisted-pair PROFIBUS cable complying with EN50170.

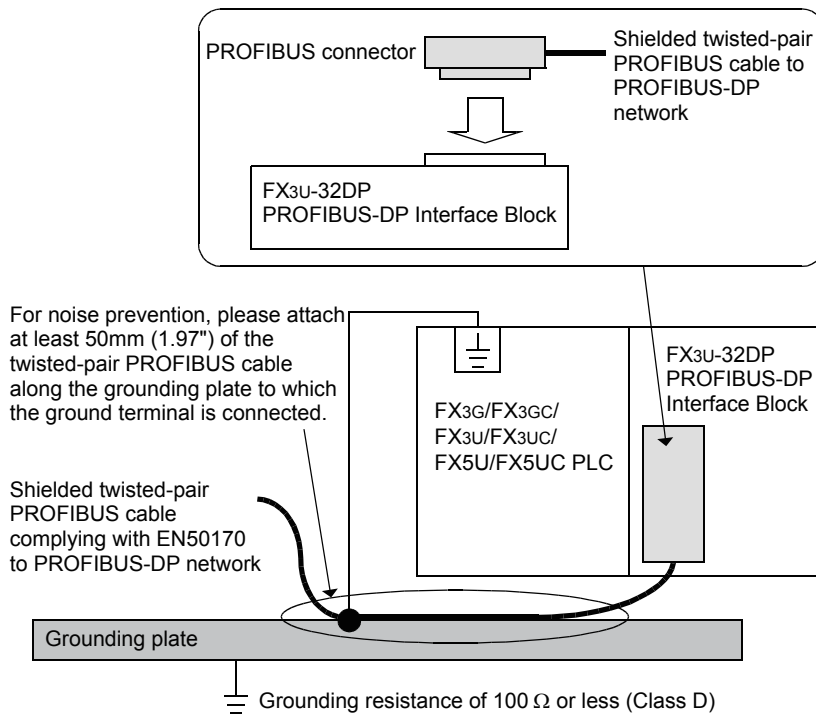

4.3 Grounding

Ground the cable as stated below.

- Use a grounding resistor of 100 Ω or less.
 - Ground the cables independently for best results.
- When independent grounding is not used, use "shared grounding" as follows.

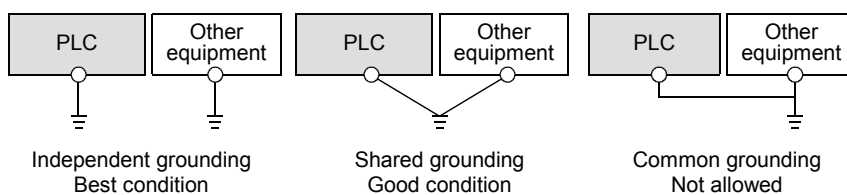

- The grounding wire size should be AWG 14 (2 mm²) or larger.
- The grounding point should be as close to the PLC as possible, and all grounding wire should be as short as possible.

4.4 Bus Terminator

To avoid signal reflections, connect a self-terminating DP-Connector/Device at each end of the PROFIBUS-DP Network.

Note

The FX3U-32DP is not self-terminated.

5. Communication Outline on PROFIBUS-DP Network

5.1 Cyclic Input/Output Data Communication

Cyclic I/O Data Communication exchanges data periodically (e.g. I/O, analog input value, etc.) between the DP-Master and the 32DP. The 32DP can exchange data in cyclic I/O data communication (not in the Data Consistency Mode) with the DP-Master when the I/O data ≤ 16 bit, whereas the 32DP exchanges data in the Data Consistency Mode with the DP-Master when the I/O data > 16 bit.

The DP-Master configuration tool (e.g. GX Configurator-DP) automatically sets the Data Consistency Mode ON, depending on the data size to exchange, while users can also set this mode ON/OFF manually.

BFM #98 and #298 show the mode status. The allowable data size is a maximum of 144Byte.

→ For flag allocations, refer to Chapter 6

→ For details on the Cyclic Input/Output Data Send/Receive Areas, refer to Chapter 6

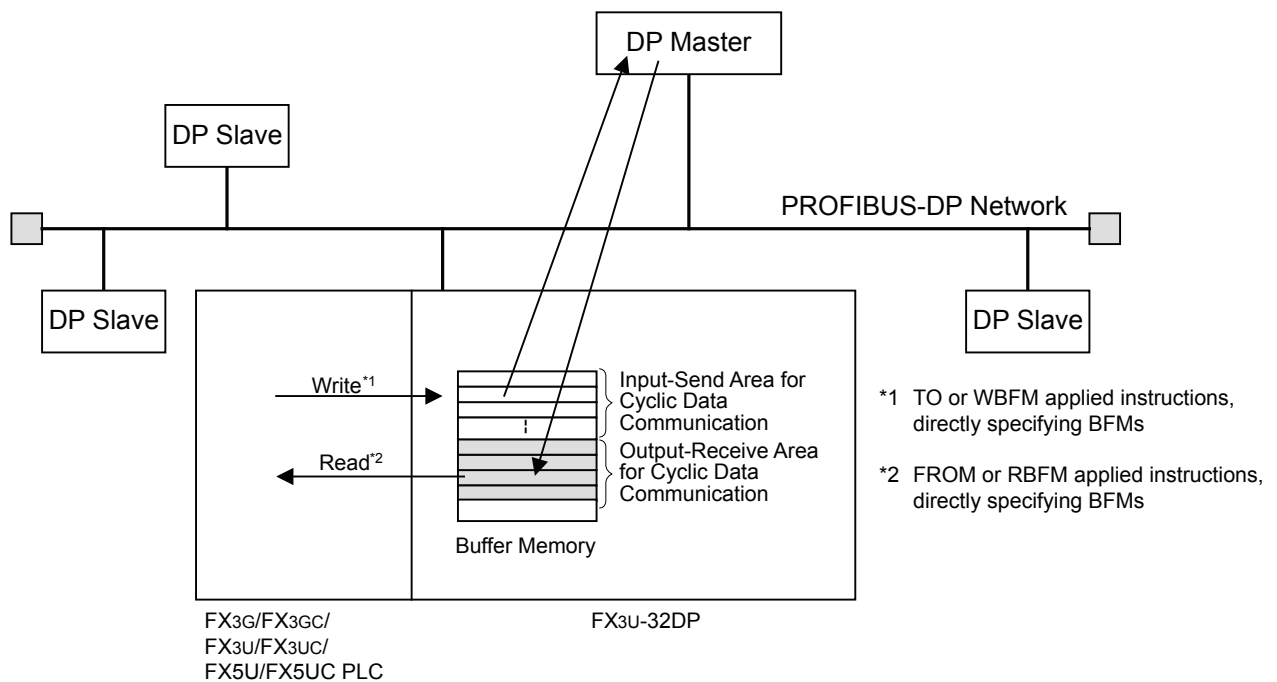

- 1 Introduction
- 2 Specifications
- 3 Installation
- 4 Wiring
- 5 Comm. Outline on PROFIBUS-DP Network
- 6 Buffer Memory Allocation
- 7 Parameter Setting and Network Configuration
- 8 Example Program
- 9 Diagnostics

5.1.1 Cyclic Data Consistency

When the Cyclic Data Consistency Activate/Deactivate Flags turn ON, the cyclic data process behaves as follows:

→ For details on Cyclic Communication related flags, refer to Chapter 6

Cyclic Input Data Consistency (Cyclic Input Data Consistency Activate/Deactivate Flag BFM#98 = ON)

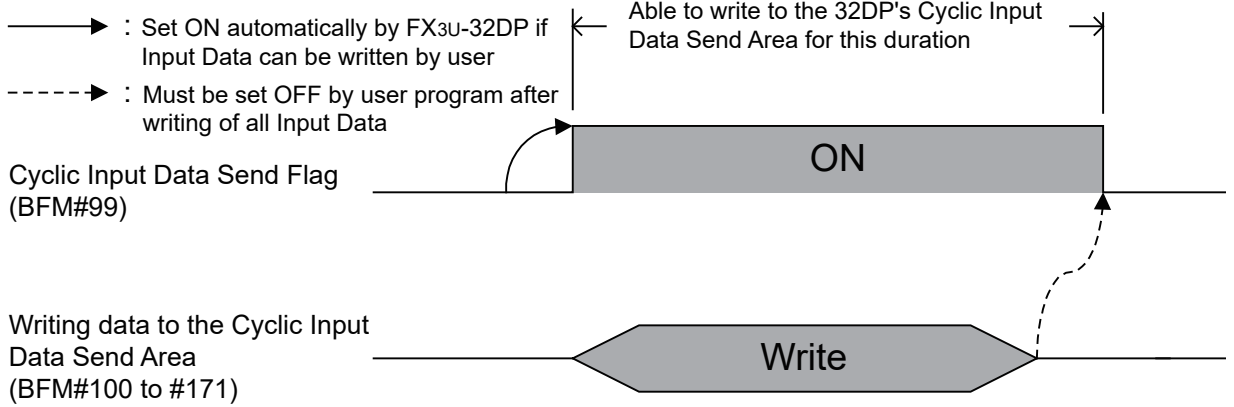

Cyclic Output Data Consistency (Cyclic Output Data Consistency Activate/Deactivate Flag BFM#298 = ON)

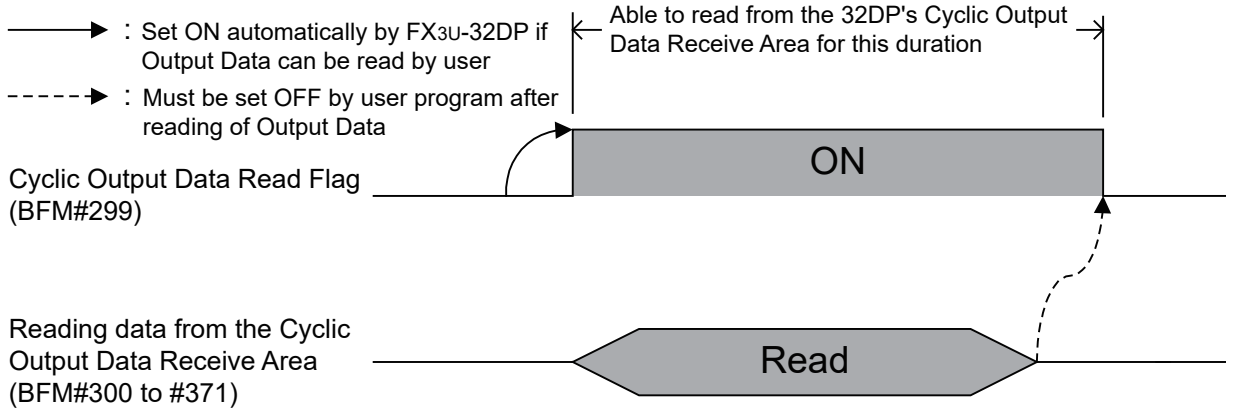

5.2 Acyclic Input/Output Data Communication

Acyclic I/O data communication is available for changing DP-Slave parameters during cyclic communication. The allowable data size is a maximum of 140Byte. Cyclic Communication has a higher priority than Acyclic Communication. Acyclic Communication is always processed in the Data Consistency Mode.

→ For flag allocations, refer to Chapter 6
 → For details on Acyclic Input-Send/Output-Receive Area, refer to Chapter 6

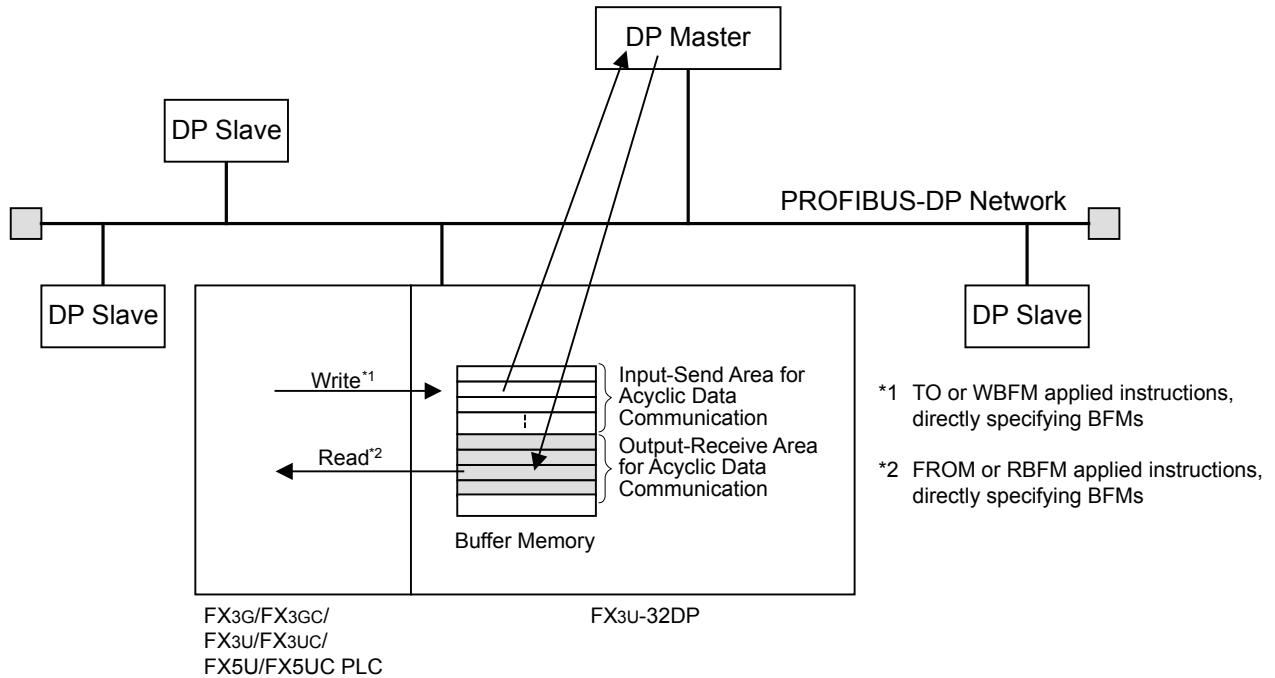

- 1 Introduction
- 2 Specifications
- 3 Installation
- 4 Wiring
- 5 Comm. Outline on PROFIBUS-DP Network
- 6 Buffer Memory Allocation
- 7 Parameter Setting and Network Configuration
- 8 Example Program
- 9 Diagnostics

5.2.1 Acyclic Data Consistency

Acyclic Data Communication is always processed in the Data Consistency Mode, regardless of the BFM#98 or BFM#298 settings. The 32DP supports Class 1 and 2 Acyclic Communication.

→ For details on Acyclic Communication related flags, refer to Chapter 6

Acyclic Input Data Communication

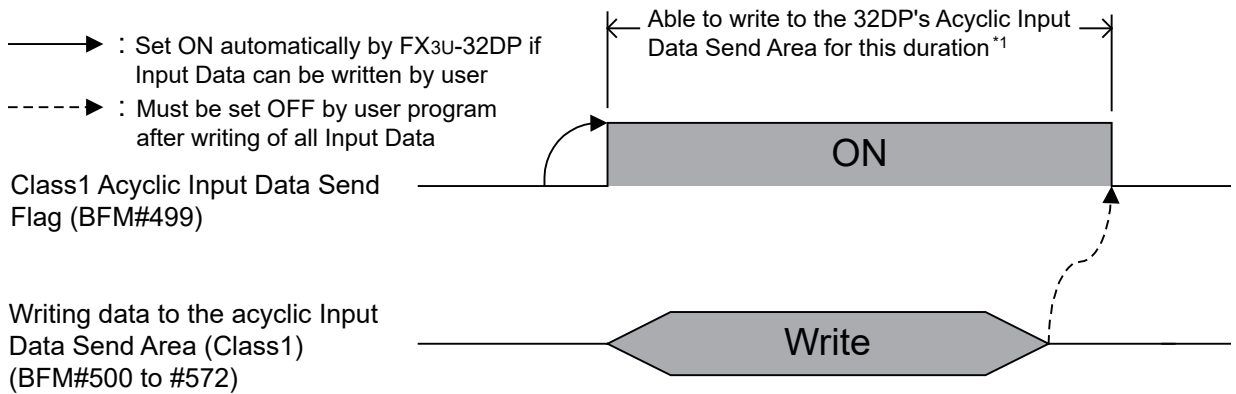

Acyclic Output Data Communication

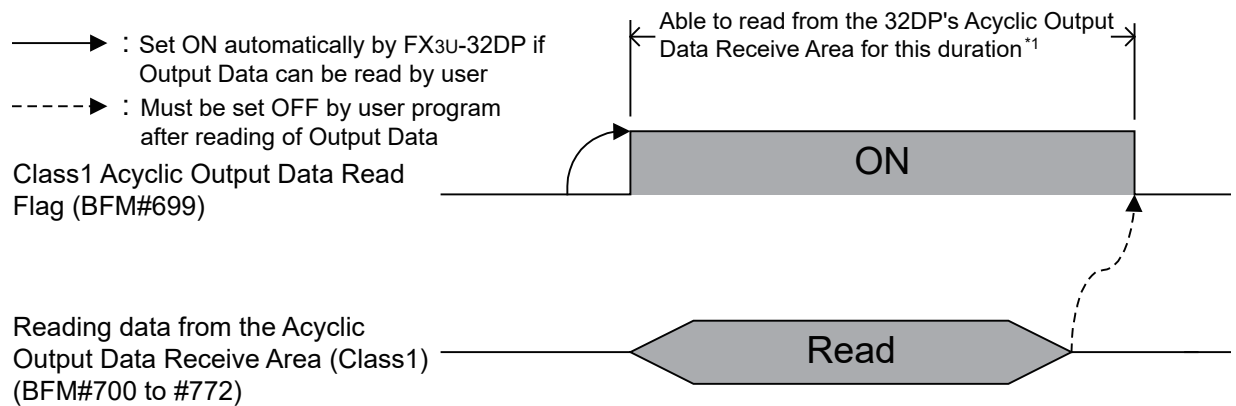

*1. For Class 1: To prevent an "Acyclic Class 1 Response Timeout," the response time must be smaller than 10 seconds.

For Class 2: The "Acyclic Class 2 Response Timeout" will be set by the Initiate-request (SendTimeout value) from the DP-Master.

Note : INPUT/OUTPUT to where?

When this manual references INPUT/OUTPUT for communication data on the PROFIBUS-DP network, it refers to data from the DP-Master's point of view. Therefore, CYCLIC INPUT DATA means THE CYCLIC DATA STREAMING FROM DP-SLAVE TO DP-MASTER. On the other hand, ACYCLIC OUTPUT DATA, for example, means THE ACYCLIC DATA STREAMING FROM DP-MASTER TO DP-SLAVE.

5.3 Diagnostic Data Communication

The 32DP classifies the diagnostic data into two categories : Alarm Message and Status Message. When the 32DP's DP-V1 functionality is ON (BFM#35 Bit0 = 1) and the Alarm/Status Switch is OFF (BFM#1299 Bit0 = 0), the 32DP can send a diagnostic message as a high-prioritized Alarm Message. This Alarm Message from the 32DP needs to be acknowledged by the DP-Master. If this alarm-acknowledging step is not necessary, the 32DP can send a diagnostic message as a low-prioritized Status Message when users set the Alarm/Status Switch (BFM#1299 Bit0 = 1).

The content of BFM#1299 Bit0 is mapped to BFM#35 Bit2.

Note

If BFM#1299 Bit 0 turns to 1 when BFM#35 Bit0 = 0, BFM#38 Bit13 displays " BFM#1299 Setting Error."
 → For flag allocations, refer to Chapter 6
 → For details on Slave Diagnostic Data, refer to Chapter 6

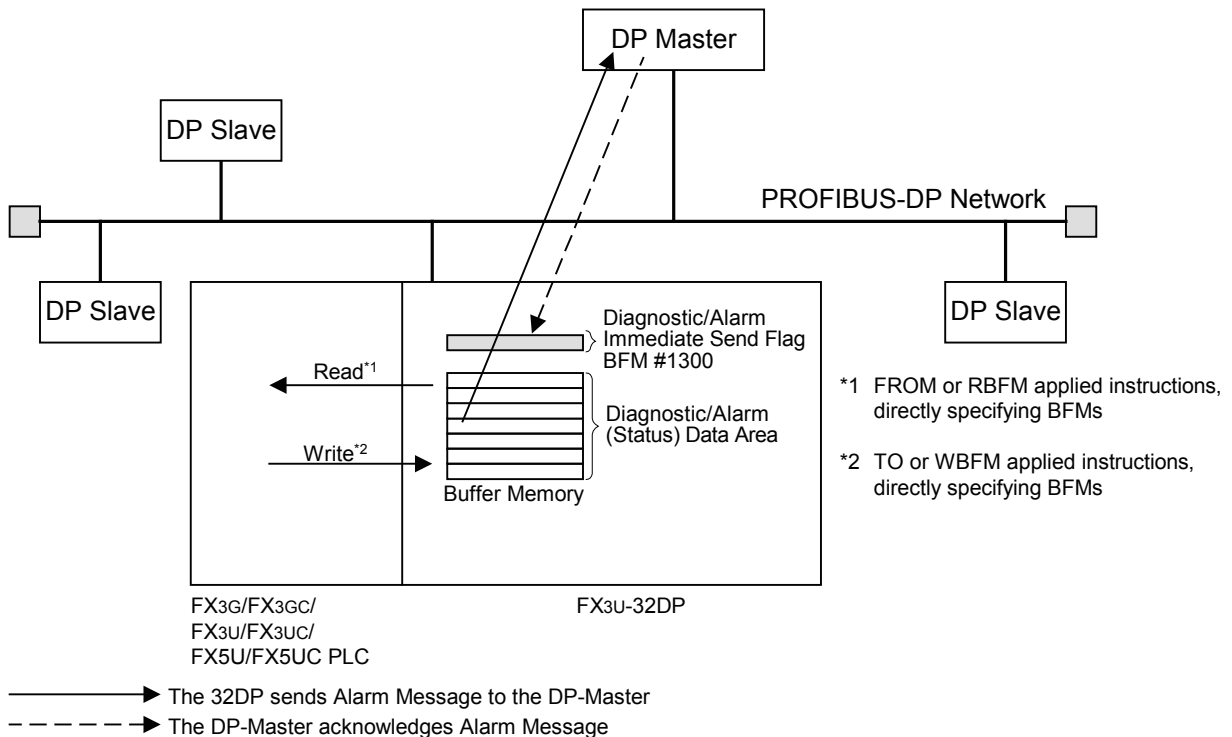

5.3.1 Diagnostic Data Communication

Diagnostic Data Communication is always processed in the Data Consistency mode, regardless of the BFM#98 setting.

→ For details on Diagnostic Data related flags, refer to Chapter 6

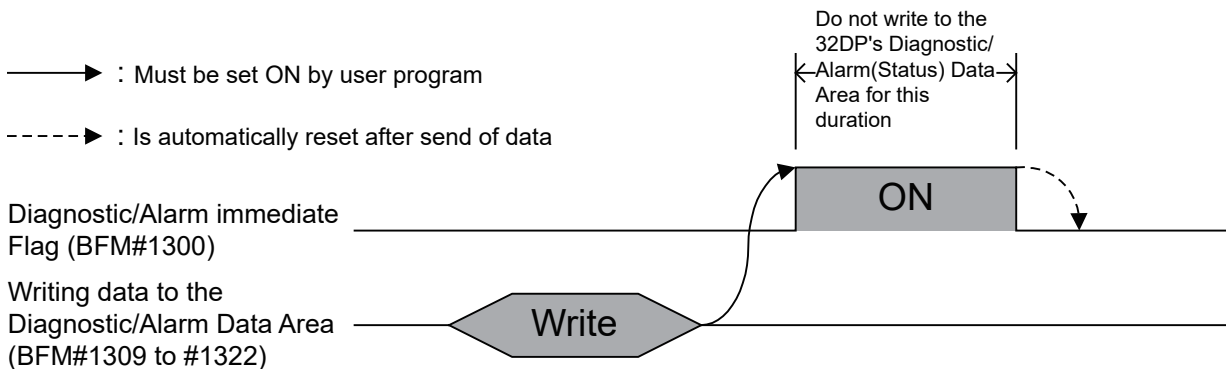

1 Introduction

2 Specifications

3 Installation

4 Wiring

5 Comm. Outline on PROFIBUS-DP Network

6 Buffer Memory Allocation

7 Parameter Setting and Network Configuration

8 Example Program

9 Diagnostics

5.4 Global Control

The 32DP supports SYNC, UNSYNC, FREEZE and UNFREEZE Global Control Services. The default setting is UNSYNC and UNFREEZE in Global Control Mode.

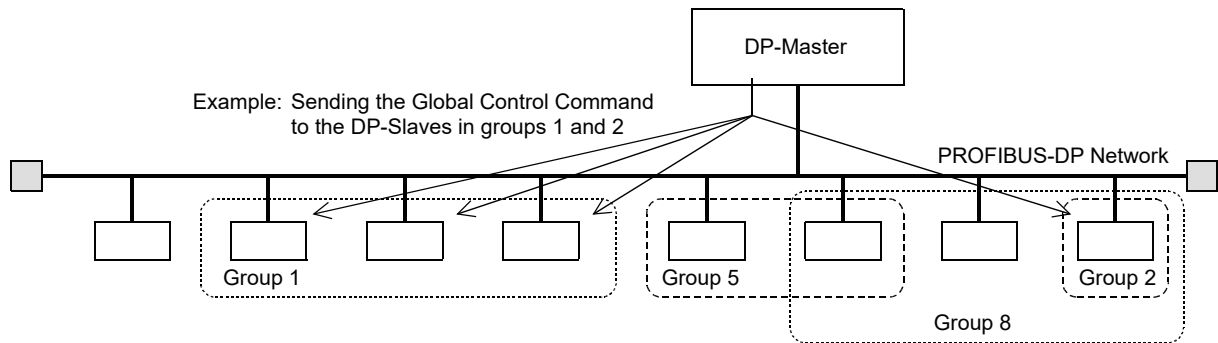

5.4.1 SYNC and UNSYNC Global Control

The SYNC/UNSYNC Global Control handles the cyclic output data from the DP-Master to the 32DP as follows:

→ For details on Global Control, refer to the DP-Master's Manual
→ For Cyclic Output Data, refer to Chapter 6

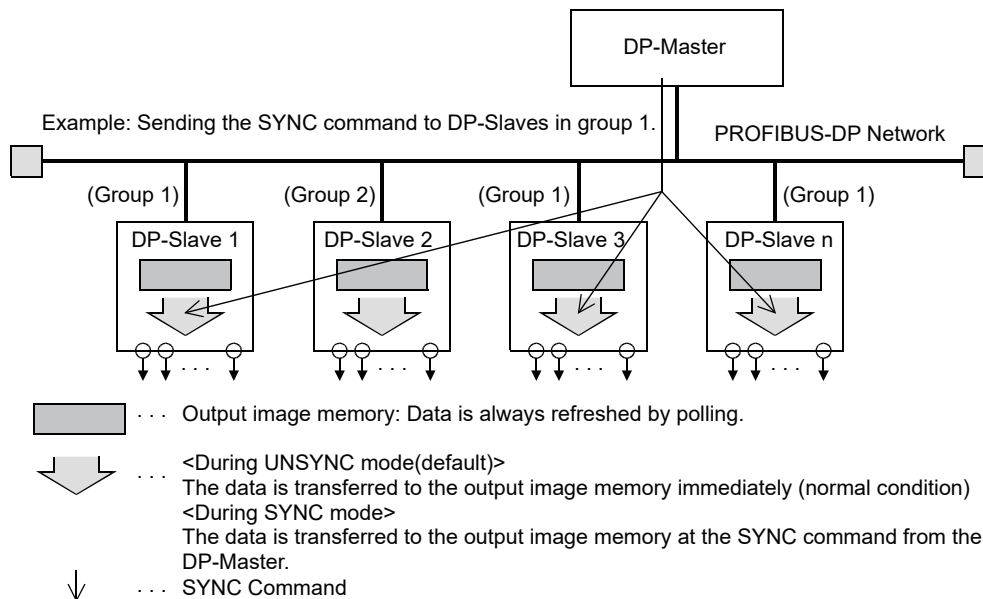

- 1) SYNC Global Control command
In SYNC mode, the cyclic output data to the 32DP in the group(s) specified by DP-Master is not immediately transferred to the output image memory of the 32DP. The 32DP holds the cyclic output data until the next SYNC/UNSYNC Global Control command. When receiving the next SYNC/UNSYNC command, the 32DP transfers the data to its output image memory.
- 2) UNSYNC Global Control command
The UNSYNC Global Control command releases the 32DP from SYNC mode and the 32DP starts updating the cyclic output data continuously.
By specifying groups of DP-Slaves, the DP-Master sends the UNSYNC command arbitrarily to those DP-Slave groups, similar to the SYNC command.

Note

When using SYNC Global Control command, the cyclic output data (sent to the DP-Slave) is not refreshed until the next SYNC or UNSYNC global command is sent to the DP-Slave.

5.4.2 FREEZE and UNFREEZE Global Control

The FREEZE/UNFREEZE Global Control handles the cyclic input data communication from the 32DP to the DP-Master.

→ For details on Global Control, refer to the DP-Master's Manual
→ For Cyclic Input Data, refer to Chapter 6

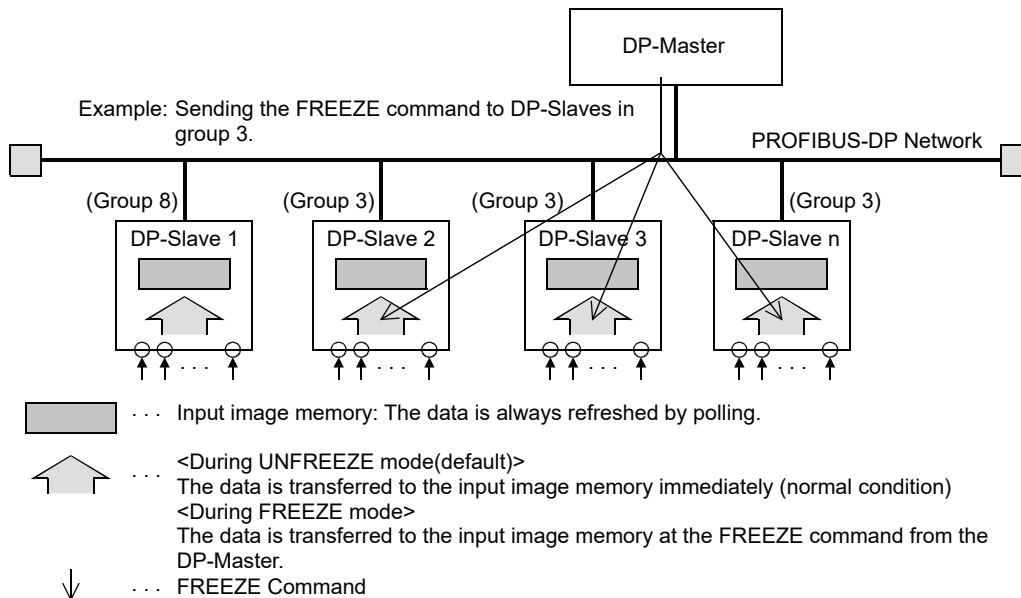

1) FREEZE Global Control command

In Freeze mode, the cyclic input data from the 32DP in the group specified by DP-Master is not immediately transferred to its input image memory. The 32DP holds the cyclic input data until the next FREEZE/UNFREEZE Global Control command. When receiving the next FREEZE/UNFREEZE command, the 32DP transfers the data to the input image memory.

2) UNFREEZE Global Control command

An UNFREEZE Global Control command releases the 32DP from FREEZE mode and the 32DP starts updating the cyclic input data continuously.

By specifying groups of DP-Slaves, the DP-Master sends the UNFREEZE command arbitrarily to those DP-Slave groups, similar to the FREEZE command.

Note

When using the FREEZE Global Control command, the cyclic input data (received from the DP-Slave) is not refreshed until the next FREEZE or UNFREEZE global command to the DP-Slave.

6. Buffer Memory Allocation

6.1 Buffer Memory (BFM) List

BFM No.	Description	BFM Access		Reference
		Read	Write	
BFM#0 to BFM#19	Cyclic I/O Data Area Compatible with FX0N-32NT-DP	✓	✓	6.2
BFM#20	Data Exchange Status Register	✓	–	6.3
BFM#21	Swap Byte Order	✓	–	6.4
BFM#22	Cyclic Input Data Length	✓	–	6.5
BFM#23	Cyclic Output Data Length	✓	–	6.6
BFM#24	Transmission Speed	✓	–	6.7
BFM#25	DP Communication Status Register	✓	✓	6.8
BFM#26	PROFIBUS Module ID: PNO-Nr. F332 Hex	✓	–	6.9
BFM#27	Slave Address	✓	✓	6.10
BFM#28	User Diagnostics	✓	✓	6.11
BFM#29	Error Status Register	✓	✓	6.12
BFM#30	Module ID Code	✓	–	6.13
BFM#31 to BFM#32	Not Available	–	–	–
BFM#33	Master Address	✓	–	6.14
BFM#34	Allocated Group ID Number	✓	–	6.15
BFM#35	DP-V1 Communication Parameter	✓	–	6.16
BFM#36	Start/Stop DP Communication	✓	✓	6.17
BFM#37	Consistency Handling Error Flags	✓	✓	6.18
BFM#38	Setting Error Flags	✓	✓	6.19
BFM#39 to BFM#97	Not Available			
BFM#98	Cyclic Input Data Consistency Activate/Deactivate Flag	✓	✓	6.20
BFM#99	Cyclic Input Data Send Flag	✓	✓	6.21
BFM#100 to BFM#171	Cyclic Input Data Send Area Max. 144 Byte	✓	✓	6.22
BFM#172 to BFM#297	Not Available	–	–	–
BFM#298	Cyclic Output Data Consistency Activate/Deactivate Flag	✓	✓	6.23
BFM#299	Cyclic Output Data Read Flag	✓	✓	6.24
BFM#300 to BFM#371	Cyclic Output Data Receive Area Max. 144 Byte	✓	–	6.25
BFM#372 to BFM#498	Not Available	–	–	–
BEM#499	Acyclic Input Data Send Flag (Class1)	✓	✓	6.26
BFM#500 to BFM#572	Acyclic Input Data Send Area (Class1) Max. 140 Byte	✓	✓*1	6.27
BFM#573 to BFM#698	Not Available	–	–	–
BFM#699	Acyclic Output Data Read Flag (Class1)	✓	✓	6.28
BFM#700 to BFM#772	Acyclic Output Data Receive Area (Class1) Max. 140 Byte	✓	–	6.29

BFM No.	Description	BFM Access		Reference
		Read	Write	
BFM#773 to BFM#898	Not Available	-	-	-
BFM#899	Acyclic Input Data Send Flag (Class2)	✓	✓	6.30
BFM#900 to BFM#972	Acyclic Input Data Send Area (Class2) Max. 140 Byte	✓	✓*2	6.31
BFM#973 to BFM#1098	Not Available	-	-	-
BFM#1099	Acyclic Output Data Read Flag (Class2)	✓	✓	6.32
BFM#1100 to BFM#1172	Acyclic Output Data Receive Area (Class2) Max. 140 Byte	✓	-	6.33
BFM#1173 to BFM#1297	Not Available	-	-	-
BFM#1298	Reset Extended Diagnostic/Alarm Data Area Flag	✓	✓	6.34
BFM#1299	Alarm/Status Switch	✓	✓	6.35
BFM#1300	Diagnostic/Alarm Immediate Send Flag	✓	✓	6.36
BFM#1301 to BFM#1325	Diagnostic/Alarm(Status) Data Area	✓	✓*3	6.37

- *1. BFM#500 to 502 are Read Only.
- *2. BFM#900 to 902 are Read Only.
- *3. BFM#1301 to 1308 are Read Only.

Note

- Do not access the "Not Available" BFM's with FROM/TO instructions. Accessing BFM's that are not available may cause operation errors in the 32DP.
- Do not write to the "Read Only" BFM's with TO instructions.

INPUT/OUTPUT to where?

When this manual references INPUT/OUTPUT for communication data on the PROFIBUS-DP network, it refers to data from the DP-Master's point of view. Therefore, CYCLIC INPUT DATA means THE CYCLIC DATA STREAMING FROM DP-SLAVE TO DP-MASTER. On the other hand, ACYCLIC OUTPUT DATA, for example, means THE ACYCLIC DATA STREAMING FROM DP-MASTER TO DP-SLAVE.

6.2 Cyclic I/O Data Area Compatible with FX0N-32NT-DP [BFM #0 to BFM #19]

BFM Access : Read / Write

The 32DP allocates Byte1 - 40 of Cyclic Output Data by the FROM instruction to the Cyclic Output Data Receive Area (BFM#300 to #371), while it allocates Byte1 - 40 of Cyclic Input Data by the TO instruction to the Cyclic Input Data Send Area (BFM#100 to #171).*1

- *1. These redundant allocations are implemented for compatibility to the FX0N-32NT-DP. Regardless of the data amount, it is recommended for most users to refer to the Cyclic Input/Output Data Receive/Send Area (BFM#100 to #171/BFM#300 to 371).

FROM Instruction Access

BFM Content

BFM #0	Copied from BFM #300
#1	Copied form BFM #301
⋮	⋮
#19	Copied from BFM #319

TO Instruction Access

BFM Content

BFM #0	Writing to BFM #100
#1	Writing to BFM #101
⋮	⋮
#19	Writing to BFM #119

- 1 Introduction
- 2 Specifications
- 3 Installation
- 4 Wiring
- 5 Comm. Outline on PROFIBUS-DP Network
- 6 Buffer Memory Allocation
- 7 Parameter Setting and Network Configuration
- 8 Example Program
- 9 Diagnostics

6.3 Data Exchange Status Register [BFM #20]

BFM Access : Read Only

This BFM shows the data exchange status.

Bit No.	Name	Description
Bit 0	Data Exchange Bit	ON when the 32DP is in the Data Exchange Mode
Bit1	Clear/Fail-Safe State	ON when the 32DP is in the Clear/Fail-Safe status
Bit2 to Bit15	Not Available	–

The following values show the PROFIBUS-DP communication status.

Value	Description
K0	The 32DP is in STOP/OFFLINE mode BFM25 Bit0 is " 0 " when the 32DP established no communication, the 32DP is OFFLINE BFM25 Bit0 is " 1 " when the 32DP established a communication, the 32DP is ONLINE
K1	The 32DP is in RUN mode
K3	The 32DP is in Clear/Fail-Safe mode

6.4 Swap Byte Order [BFM #21 Bit0 and Bit1]

BFM Access : Read Only

This BFM determines the byte-order swap for the I/O data and diagnostic data. ^{*1}

Bit No.	Name	Description
Bit 0	Cyclic Data Swap Byte Order	When turning this bit ON, the 32DP swaps the low and high byte of cyclic I/O data and diagnostic (alarm) messages
Bit1	Acyclic Data Swap Byte Order	When turning this bit ON, the 32DP swaps the low and high byte of acyclic I/O data
Bit2 to 15	Not Available	–

*1. The 32DP does not swap the I&M data byte-order, therefore the I&M data byte-order is always the high-byte followed by the low-byte.

Note

The Swap Byte Order can be set up by the DP-Master Configuration Tool. When using GX Configurator-DP, the Swap Byte Order is specified in the Extended User Parameters for the Slave.

→ For details, refer to Subsection 7.1.2

6.5 Cyclic Input Data Length [BFM #22]

BFM Access : Read Only

This BFM shows the cyclic input data length. The valid range lies from 0 to 72 words. When the value is out of the range, The 32DP writes "0xFF" to this BFM.

6.6 Cyclic Output Data Length [BFM #23]

BFM Access : Read Only

This BFM shows the cyclic output data length. The valid range lies from 0 to 72 words. When the value is out of the range, The 32DP writes "0xFF" to this BFM.

6.7 Transmission Speed [BFM #24]

BFM Access : Read Only

This BFM shows the current transmission speed of the DP network. The transmission speed depends on the DP-Master setting. When the 32DP is in the transmission speed search mode, the value remains "FFFFh" until the 32DP finds an applicable transmission speed.

Value (Hex)	Transmission Speed (bps)	Value (Hex)	Transmission Speed (bps)
96E2 H	9.6 kbps	05E5 H	500 kbps
19E3 H	19.2 kbps	15E5 H	1.5 Mbps
45E3 H	45.45 kbps	03E6 H	3 Mbps
93E3 H	93.75 kbps	06E6 H	6 Mbps
18E4 H	187.5 kbps	12E6 H	12 Mbps

6.8 DP Communication Status Register [BFM #25]

BFM Access : Read / Write (0 to Bit8 only)

This BFM shows the DP communication status as follows.

Bit No.	Name	Description
Bit 0	Module ONLINE/OFFLINE	ON when the module is ONLINE
Bit 1	Fail-Safe State Activate Flag	ON when the DP-Master activates the Fail-Safe mode
Bit 2	Diagnostics Status Flag	ON when the DP-Master does not retrieve any new diagnostic data, nor any new alarm data
Bit 3	DP Watchdog Base	ON when the 1ms Watchdog Base is enabled
Bit 4 Bit 5	DP-State	00b = Waiting Parameters 01b = Waiting Configuration 10b = Exchanging Data 11b = not possible
Bit 6 Bit 7	DP-Watchdog-State	00b = Baud Search State 01b = Baud Control State 10b = DP Control State 11b = not possible
Bit 8 *1	Address Change Impossible Flag	Turns ON automatically when the 32DP receives Address Change Impossible command from the DP-Master The allowable access is only to turn this bit OFF
Bit 9	Clear Data Global Control	ON when the 32DP receives the clear data command
Bit 10	UNFREEZE Global Control	The 32DP received the UNFREEZE command
Bit 11	FREEZE Global Control	The 32DP received the FREEZE command
Bit 12	UNSYNC Global Control	The 32DP received the UNSYNC command
Bit 13	SYNC Global Control	The 32DP received the SYNC command
Bit 14 *2	FREEZE Supported	ON when the FREEZE mode is active
Bit 15 *2	SYNC Supported	ON when the SYNC mode is active

- *1. To avoid "Consistency Error" by changing the slave address while the Address Change Impossible Flag is ON, write "FEFFh" to BFM#25 to turn OFF BFM#25 Bit8.
- *2. PROFIBUS Configuration Tool (e.g. GX-Configurator DP) will automatically turns these bits ON if specified.

6.9 PROFIBUS Module ID [BFM #26]

BFM Access : Read Only

This BFM shows the ID code that the PROFIBUS User Organization (PNO) has issued to the 32DP : F332h.

6.10 Slave Address [BFM #27]

BFM Access : Read / Write

This BFM shows the actual slave address. When changing the slave address with a TO instruction, users must write the new address value (0 - 126d) to this BFM, while verifying that the configured DP address will match the projected DP address.

When the slave address is changed more than once in 5 seconds, the "Consistency Error" (BFM#29 Bit5) and "Change Slave Address EEPROM Error" (BFM#37 Bit10) appear, and the 32DP latches the latest valid address. For changing the slave address via SSA-telegram, the valid address setting range is (0 to 125d).

When the new address value is outside the range (0 to 126d), a "Slave Address Change Error" appears, and the 32DP latches the latest valid address. The slave address can only be changed when the slave is in STOP mode (BFM#20 Bit0 = OFF) with the "Address Change Impossible Flag" set to OFF (BFM#25 Bit8). When the user changes the slave address with the "Address Change Impossible Flag" set to ON (BFM#25 Bit8), the "Consistency Error" (BFM#29 Bit5) and "Change Slave Address EEPROM Error" (BFM#37 Bit10) appear.

→ **For details on the Address Change Impossible Flag, refer to Section 6.8**

6.11 User Diagnostics [BFM #28]

BFM Access : Read / Write

By writing to this BFM, the 32DP can send user-diagnostic data with high priority to the DP-Master. The data from this BFM is handled as the extended diagnostic data by the DP-Master. When using this functionality, users need to define the meaning for each bit. This functionality is compatible to the FX0N-32NT-DP. The 32DP maps this BFM to BFM#1307.

→ **For the details on other diagnostic data, refer to Section 6.37**

6.12 Error Status Register [BFM #29 Bit0 to Bit13]

BFM Access : Read / Write

This BFM shows the 32DP's error status. In the General Error (BFM#29 Bit0 = ON), the 32DP sends the data from BFM#28 and #29 as diagnostic data to the DP-Master, while suspending the normal data exchange. When turning the PLC from STOP to RUN, all BFM#29 Bits turn OFF except Bit3, 4, 12 and 13. The 32DP maps this BFM to BFM#1308.

Bit No.	Name	Description
Bit 0	General Error	ON when any one or more of BFM#29's Bit1, 8 to 13 is ON
Bit 1	PLC in STOP mode	ON when the connected PLC is in STOP mode, and turns OFF when the PLC switches into RUN
Bit 2	Extended-user Alarm/Diagnostic Data Not Yet Sent Flag	ON when BFM#25 Bit2 is not 0
Bit 3	Hardware Error	ON when the 32DP detects an internal hardware error
Bit 4	EEPROM Error	ON when the slave address data in the EEPROM is corrupt
Bit 5	Consistency Handling Error Flags	ON when the 32DP detects a consistency error *1
Bit 6	Setting Error Flag	ON when the 32DP detects an incorrect BFM setting *2
Bit 7	Not Available	—
Bit 8	Watchdog DP Timeout	ON when the 32DP detects no reply from the DP-Master within the preset watchdog time
Bit 9	Acyclic Communication Error	ON when an error occurs in acyclic communication *3
Bit 10	Configuration Error	ON when the 32DP receives incorrect Config Data
Bit 11	Parameter Error	ON when the 32DP receives incorrect Parameter Data
Bit 12	Slave Address Change Error	ON when the 32DP detects an incorrect address or the address outside the range : 0 to 126*4
Bit 13	Slave "Reset No Address Change" Error	ON when the 32DP detects an error due to resetting the Address Change Impossible Flag (BFM#25 Bit8) in Data Exchange mode, or resetting this flag while the access to BFM#25 Bit8 is disabled
Bit 14 to 15	Not Available	—

*1. BFM#37 shows the error reason.

→ For details on BFM#37, refer to Section 6.18

*2. BFM#38 shows the error reason.

→ For details on BFM#38, refer to Section 6.19

*3. BFM#35 shows the error reason.

→ For details on BFM#35, refer to Section 6.16

*4. BFM#27 includes additional information.

→ For details on BFM#27, refer to Section 6.10

6.13 Module ID Code [BFM #30]

BFM Access : Read Only

This BFM shows " 7150 " as the Module ID Code of the 32DP, given by its vendor.

6.14 Master Address [BFM #33]

BFM Access : Read Only

This BFM shows the DP-Master address on the DP network, where the 32DP exists. When the DP-Master does not recognize the 32DP, this BFM value is 00FFh.

1

Introduction

2

Specifications

3

Installation

4

Wiring

5

Comm. Outline on PROFIBUS-DP Network

6

Buffer Memory Allocation

7

Parameter Setting and Network Configuration

8

Example Program

9

Diagnostics

6.15 Allocated Group ID Number [BFM #34]

BFM Access : Read Only

This BFM shows the groups including the 32DP.

Bit No.	Name	Description
Bit 0	Allocated Group 1	On when the 32DP belongs to Group 1
Bit 1	Allocated Group 2	On when the 32DP belongs to Group 2
Bit 2	Allocated Group 3	On when the 32DP belongs to Group 3
Bit 3	Allocated Group 4	On when the 32DP belongs to Group 4
Bit 4	Allocated Group 5	On when the 32DP belongs to Group 5
Bit 5	Allocated Group 6	On when the 32DP belongs to Group 6
Bit 6	Allocated Group 7	On when the 32DP belongs to Group 7
Bit 7	Allocated Group 8	On when the 32DP belongs to Group 8
Bit 8 to 15	Not Available	–

The DP-Master can allocate the 32DP to two or more groups simultaneously. When the BFM#34 = 0, the DP-Master has not allocated the 32DP to any group.

6.16 DP-V1 Communication Parameter [BFM #35]

BFM Access : Read Only

This BFM shows the 32DP's communication status. Depending on the module status, this BFM content varies as follows.

Bit No.	Name	Description
Bit 0	DP-V1 acyclic service enabled	ON when the DP-V1 service is enabled
Bit 1	Not Available	–
Bit 2	Alarm/Status Switch Status *1	Same status as BFM#1299 Bit0
Bit 3 to 7	Not Available	–
Bit 8 *2	Class1 General Service Error	ON when BFM#35 Bit9 or Bit10 is ON ON when an error occurs during the ALARM processing ON when an error occurs in the Class1 Transmission Delay
Bit 9 *2	Class1 Read Error	ON when an error occurs during the acyclic Class1 read service
Bit 10 *2	Class1 Write Error	ON when an error occurs during the acyclic Class1 write service
Bit 11	Not Available	–
Bit 12 *2	Class2 General Error	ON when BFM#35 Bit13, Bit14 or Bit15 is ON ON when an error occurs in Class2 transmission delay
Bit 13 *2	Class2 Read Error	ON when an error occurs during the acyclic Class2 read service
Bit 14 *2	Class2 Write Error	ON when an error occurs during the acyclic Class2 write service
Bit 15 *2	Class2 Transport Error	ON when an error occurs during the acyclic Class2 transport service ON when an error occurs in the Class2 transmission delay

*1. BFM#35 Bit2 corresponds to BFM#1299 Bit0.

→ For details on BFM#1299, refer to Section 6.35

*2. If any of these bits is ON, the 32DP aborts the acyclic service and sends the corresponding error to the DP-Master.

6.17 Start/Stop DP Communication [BFM #36 Bit0]

BFM Access : Read / Write

This BFM manually starts/stops the 32DP's DP Communication. The BFM value decides the 32DP's communication state as follows.

Bit No.	Description
Bit0 = 0	The 32DP stops the DP Communication when the PLC is in STOP
	The 32DP starts the DP Communication when the PLC is in RUN
Bit0 = 1	The 32DP stays in the DP Communication regardless of the PLC RUN/STOP

6.18 Consistency Handling Error Flags [BFM #37]

BFM Access : Read / Write (Valid Value : 0 only)

This BFM shows Consistency Handling Error Flags. A consistency error occurs when users read/write BFMs while they are being accessed by another instruction.

Error Status Register BFM#29 Bit5 also turns ON when a consistency error occurs. By resetting BFM#29 Bit5, BFM#37 resets. By writing 0 to BFM#37, BFM#29 Bit5 resets as well as Consistency Handling Error Flags.

Bit No.	Name	Description
Bit 0	Cyclic Input Data Exchange Consistency Error	ON when writing to the cyclic Input-Send Area while BFM#99 is 0
Bit 1	Cyclic Output Data Exchange Consistency Error	ON when reading the Cyclic Output Data Receive Area while BFM#299 is 0
Bit 2	Acyclic Class1 Input Data Exchange Consistency Error	ON when writing to the Acyclic Input Data Send Area while BFM#499 is 0
Bit 3	Acyclic Class1 Output Data Exchange Consistency Error	ON when reading the Acyclic Output Data Receive Area while BFM#699 is 0
Bit 4	Acyclic Class2 Input Data Exchange Consistency Error	ON when writing to the Acyclic Input Data Send Area while BFM#899 is 0
Bit 5	Acyclic Class2 Output Data Exchange Consistency Error	ON when reading the Acyclic Output Data Receive Area while BFM#1099 is 0
Bit 6 to 7	Not Available	-
Bit 8	Slave Diagnostics Send Consistency Error	ON when writing to the diagnostic/alarm(status) data area while BFM#1300 is 1
Bit 9	Change Slave Address Consistency Error	ON when changing the 32DP address while the 32DP is in Data Exchange mode or BFM#25 Bit8 (Address Change Impossible Flag) is ON
Bit 10	Change Slave Address EEPROM Error	ON when changing the 32DP address more than once in 5 seconds ^{*1}
Bit 11 to 15	Not Available	-

→ For details on BFM#25 Bit8, refer to Section 6.8

*1. Also refer to BFM#27.

→ For details on BFM#27, refer to Section 6.10

Note

A consistency error also occurs when users monitor the output data receive area of the 32DP BFMs in data consistency mode with programming Software (i. e. GX Developer).

6.19 Setting Error Flag [BFM #38]

BFM Access : Read / Write (Valid Value : 0 bitwise)

This BFM shows the setting error reasons. This BFM corresponds to BFM#29 Bit6. By resetting BFM#29 Bit6, BFM#38 also resets. By writing 0 to each bit in BFM#38, each flag resets individually.

Bit No.	Description
Bit 0	ON when writing to " Not Available " or " Read Only " BFMs
Bit 1	ON when writing an incorrect value to [BFM#36 Start/Stop DP-Communication] (Valid write value for BFM#36: 0 or 1)
Bit 2	Not Available
Bit 3	Not Available
Bit 4	ON when writing an incorrect value to [BFM#99 Cyclic Input Data Send Flag] (Valid write value for BFM#99: 0 only)
Bit 5	ON when writing an incorrect value to [BFM#299 Cyclic Output Data Read Flag] (Valid write value for BFM#299: 0 only)
Bit 6	ON when writing an incorrect value to [BFM#499 Acyclic Input Data Send Flag(Class1)] (Valid write value for BFM#499: 0 only)
Bit 7	ON when writing an incorrect value to [BFM#699 Acyclic Output Data Read Flag(Class1)] (Valid write value for BFM#699: 0 only)
Bit 8	ON when writing an incorrect value to [BFM#899 Acyclic Input Data Send Flag(Class2)] (Valid write value for BFM#899: 0 only)
Bit 9	ON when writing an incorrect value to [BFM#1099 Acyclic Output Data Read Flag(Class1)] (Valid write value for BFM#1099: 0 only)
Bit 10	ON when writing an incorrect value to [BFM#98 Cyclic Input Data Consistency Activate/Deactivate Flag] (Valid write value for BFM#98: 0 or 1)
Bit 11	ON when writing an incorrect value to [BFM#298 Cyclic Output Data Consistency Activate/Deactivate Flag] (Valid write value for BFM#298: 0 or 1)
Bit 12 *1	ON when writing an incorrect value to [BFM#1298 Reset Extended User-Diagnostic/Alarm Data Area Flag] (Valid write value for BFM#1298: 0 only)
	ON when writing "0" to BFM#1298 before the DP-Master acknowledges all the Alarm Messages
	ON when writing "0" to BFM#1298 while BFM#1298 is "0" ON when writing "0" to BFM#1298 while BFM#1309 to #1322 are already "0"
Bit 13	ON when writing an incorrect value to [BFM#1299 Alarm/Status Switch] (Valid write value for BFM#1299: 0 or 1)
	ON when BFM#1299 turns ON while BFM#35 Bit0 = 0 (DP-V1 disabled)
	ON when the DP-Master does not recognize the Alarm(Status) Message from the 32DP
	ON when the DIA LED is ON (Any value in BFM#28, #29, #1298 and #1300 is not "0") ON when a process error occurs in sending a User-Diagnostic/Alarm(Status) Message
Bit 14	ON when writing an incorrect value to [BFM#1300 Diagnostic/Alarm Immediate Send Flag] (Valid write value for BFM#1300: 1 only)
Bit 15	ON when writing an incorrect value to [BFM#25 DP Communication Status Register] (Valid write value for BFM#25: FEFh only)

- *1. If writing "0" to BFM#1298 when the 32DP is not in data exchange mode, the 32DP keeps BFM#1309 - #1322 contents, whereas the 32DP clears them at the next mode switch into data exchange mode.

- For details on BFM#36, refer to Section 6.17
- For details on BFM#99, refer to Section 6.21
- For details on BFM#299, refer to Section 6.24
- For details on BFM#499, refer to Section 6.26
- For details on BFM#699, refer to Section 6.28
- For details on BFM#899, refer to Section 6.30
- For details on BFM#1099, refer to Section 6.32
- For details on BFM#98, refer to Section 6.20
- For details on BFM#298, refer to Section 6.23
- For details on BFM#1298, refer to Section 6.34
- For details on BFM#1299, refer to Section 6.35
- For details on BFM#1300, refer to Section 6.36

1	Introduction
2	Specifications
3	Installation
4	Wiring
5	Comm. Outline on PROFIBUS-DP Network
6	Buffer Memory Allocation
7	Parameter Setting and Network Configuration
8	Example Program
9	Diagnostics

6.20 Cyclic Input Data Consistency Activate/Deactivate Flag [BFM #98 Bit0]

BFM Access : Read / Write

BFM#98 Bit0 turns ON when the DP communication requires data consistency for communication data >16bit/block. The PROFIBUS Configuration Tool (e.g. GX-Configurator DP) automatically turns this bit ON. Users can set/reset this bit manually as well, for example, by PLC program.

A cyclic data communication will always set the data consistency mode, regardless of this flag's setting.

- For details on Cyclic Communication, refer to Section 5.1
- For details on the data consistency mode, refer to Section 5.1

6.21 Cyclic Input Data Send Flag [BFM #99 Bit0]

BFM Access : Read / Write

The 32DP turns this flag ON automatically when new data can be written to the Cyclic Input Data Send Area. After the writing process is finished, the user must turn this flag OFF.

- For details on the data consistency mode, refer to Section 5.1

6.22 Cyclic Input Data Send Area [BFM #100 to #171]

BFM Access : Read / Write

This is the data storage area for cyclic input data, bound to be transferred to the DP-Master. A maximum of 144 Bytes of cyclic input data can be stored.

- For details on Cyclic Communication, refer to Section 5.1

Note

When the connected PLC is in STOP, the 32DP maintains no cyclic input data. It is necessary to prepare an appropriate amount of initial data in the send buffer before the 32DP initializes the cyclic communication.

BFM Address	Upper byte	Lower byte	Bit 0
BFM #100	2nd byte	1st byte	} Copied to BFM #0 to #19 (TO instruction access)
#101	4th byte	3rd byte	
#102	6th byte	5th byte	
#103	8th byte	7th byte	
⋮			
#119	40th byte	39th byte	
#120	42nd byte	41st byte	
⋮			
#171	144th byte	143rd byte	

6.23 Cyclic Output Data Consistency Activate/Deactivate Flag [BFM #298 Bit0]

BFM Access : Read / Write

BFM#298 Bit0 turns ON when the DP communication requires the data consistency. When a user sets the data consistency mode for one or more I/O modules for the 32DP, and when the communication data between those I/O modules and the 32DP>16bit/block, the user's configuration will turn this bit ON automatically. Users can set/reset this bit manually as well.

- For details on the data consistency mode, refer to Section 5.1

6.24 Cyclic Output Data Read Flag [BFM #299 Bit0]

BFM Access : Read / Write

The 32DP turns this flag ON automatically when new cyclic output data is available in the Cyclic Output Data Receive Area. After reading the data, the user must turn this flag OFF.

- For details on the data consistency mode, refer to Section 5.1

6.25 Cyclic Output Data Receive Area [BFM #300 to #371]

BFM Access : Read Only

This is the data storage area for cyclic output data from the DP-Master. A maximum of 144 Bytes of cyclic output data can be stored.

→ For details on Cyclic Communication, refer to Section 5.1

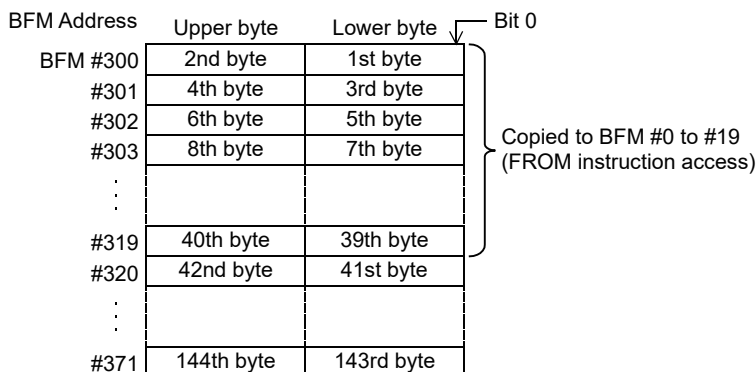

6.26 Acyclic Input Data Send Flag (Class1) [BFM #499 Bit0]

BFM Access : Read / Write

The 32DP turns this flag ON automatically when new acyclic input data can be written to the Acyclic Input Data Send Area. Acyclic Communication always requires the data consistency. After the writing process is finished, the user must turn this flag OFF.

→ For details on Acyclic Communication, refer to Section 5.2

→ For details on the data consistency mode, refer to Section 5.1

6.27 Acyclic Input Data Send Area (Class1) [BFM #500 to #572]

BFM Access : Read / Write

This is the data storage area for acyclic input data, bound to be transferred to the DP-Master. A maximum of 140 Bytes of acyclic input data can be stored.

BFM No.	Name	Description	Access
BFM #500	Slot Number	Number of the slot whose data has been read. This number is defined by the addressing for acyclic services. (Only Slot 0 possible, must be set by the DP-Master)	Read Only
BFM #501	Index	Indicates the index of the data being read. (Only Index 144 possible, must be set by the DP-Master)	Read Only
BFM #502	Length	Length of the data to be written (Data length in Bytes, requested by the DP-Master). The valid range is 0 to 140.	Read Only
BFM #503 to #572	Data	Acyclic User Input Data to be sent to the DP-Master.	Read/Write

→ For details on Acyclic Communication, refer to Section 5.2

6.28 Acyclic Output Data Read Flag (Class1) [BFM #699 Bit0]

BFM Access : Read / Write

The 32DP turns this flag ON automatically when new acyclic output data is available in the Acyclic Output Data Receive Area. Acyclic Communication always requires data consistency. After the communication process is finished, the user must turn this flag OFF.

→ For details on Acyclic Communication, refer to Section 5.2

→ For details on the data consistency mode, refer to Section 5.1

6.29 Acyclic Output Data Receive Area (Class1) [BFM #700 to #772]

BFM Access : Read Only

This is a data storage area for acyclic output data from the DP-Master. This area stores a maximum of 140Byte acyclic output data.

→ For details on Acyclic Communication, refer to Section 5.2

BFM No.	Name	Description	Access
BFM #700	Slot Number	Number of the slot whose data has been sent by DP-Master. This number is defined by the addressing for acyclic services. (Only Slot 0 possible, must be set by the DP-Master)	Read Only
BFM #701	Index	Indicates the index of the data being sent. Only Index 144 possible, must be set by the DP-Master	Read Only
BFM #702	Length	Length of the received data (size of Data in Byte). The valid range is 0 to 140.	Read Only
BFM #703 to #772	Data	Acyclic User Output Data received from the DP-Master.	Read Only

6.30 Acyclic Input Data Send Flag (Class2) [BFM #899 Bit0]

BFM Access : Read / Write

The 32DP turns this flag ON automatically when new acyclic input data can be written to the Acyclic Input Data Send Area. Acyclic Communication always requires data consistency. After the writing process is finished, the user must turn this flag OFF.

→ For details on Acyclic Communication, refer to Section 5.2
→ For details on the data consistency mode, refer to Section 5.1

6.31 Acyclic Input Data Send Area (Class2) [BFM #900 to #972]

BFM Access : Read / Write

This is a data storage area for acyclic input data, bound to be transferred to the DP-Master. This area stores a maximum of 140 Byte acyclic input data.

BFM No.	Name	Description	Access
BFM #900	Slot Number	Number of the slot whose data has been read. This number is defined by the addressing for acyclic services. (Only Slot 0 possible, must be set by the DP-Master)	Read Only
BFM #901	Index	Indicates the index of the data being sent. (Only Index 144 possible, must be set by the DP-Master)	Read Only
BFM #902	Length	Length of the data to be written (size of Data in Byte). The valid range is 0 to 140.	Read Only
BFM #903 to #972	Data	Acyclic User Input Data to be sent to the DP-Master.	Read/Write

→ For details on Acyclic Communication, refer to Section 5.2

6.32 Acyclic Output Data Read Flag (Class2) [BFM #1099 Bit0]

BFM Access : Read / Write

The 32DP turns this flag ON automatically when new acyclic output data is available in the Acyclic Output Data Receive Area. Acyclic Communication always requires data consistency. After the communication process is finished, the user must turn this flag OFF.

→ For details on Acyclic Communication, refer to Section 5.2
→ For details on the data consistency mode, refer to Section 5.1

1

Introduction

2

Specifications

3

Installation

4

Wiring

5

Comm. Outline on PROFIBUS-DP Network

6

Buffer Memory Allocation

7

Parameter Setting and Network Configuration

8

Example Program

9

Diagnostics

6.33 Acyclic Output Data Receive Area (Class2) [BFM #1100 to #1172]

BFM Access : Read Only

This is a data storage area for acyclic output data from the DP-Master. This area stores a maximum of 140 Byte acyclic output data.

→ For details on Acyclic Communication, refer to Section 5.2

BFM No.	Name	Description	Access
BFM #1100	Slot Number	Number of the slot whose data has been read. This number is defined by the addressing for acyclic services. Only Slot 0 possible, must be set by the DP-Master	Read Only
BFM #1101	Index	Indicates the index of the data being sent. Only Index 144 possible, must be set by the DP-Master	Read Only
BFM #1102	Length	Length of the data, which has been read (size of Data in Byte). The valid range is 0 to 140.	Read Only
BFM #1103 to #1172	Data	Acyclic User Output Data being received by the DP-Master.	Read Only

6.34 Reset Extended Diagnostic/Alarm Data Area Flag [BFM #1298]

Data consistency is necessary for the user-diagnostic and alarm (status) messages.

When the Extended User-Diagnostic/Alarm (Status) Data Area is not empty, this flag turns ON. Writing "0" to BFM#1298 clears the Extended User-Diagnostic/Alarm (Status) Data Area, whereas this BFM is available only when the DP-Master acknowledges all the Alarm Messages.

When writing "0" to BFM#1298 before the DP-Master acknowledges all the Alarm Messages, BFM#38 Bit12 turns ON to show the setting error.

→ For details on BFM#38, refer to Section 6.19

6.35 Alarm/Status Switch [BFM #1299 Bit0]

BFM Access : Read / Write

When the communication protocol is DP-V1 (BFM#35 Bit0 is ON), the 32DP transfers its diagnostic data by default as an Alarm Message with high priority. The Alarm Message needs to be acknowledged by the DP-Master. When this alarm acknowledging protocol is unnecessary, the diagnostic data can be sent with lower priority by specifying the data as a Status Message (setting BFM#1299 Bit0 to ON).

The 32DP diagnostic data varies depending on BFM#1299 Bit0 as follows.

Bit No.	Name	Description
Bit 0	Alarm/Status Switch	OFF when the diagnostic message is transferred as Alarm Message with high priority, requiring the DP-Master acknowledging ON when the diagnostic message is transferred as Status Message with low priority, requiring no DP-Master acknowledging
Bit 1 to 15	Not Available	-

Note

- BFM#35 Bit2 corresponds to BFM#1299 Bit0
- When enabling Alarm Message (BFM#1299 Bit0 is OFF) while DP-V1 acyclic services are disabled (BFM#35 Bit0 is OFF), the Alarm/Status Switch Error (BFM#1299 Bit13 ON) occurs.
- BFM #1299 Bit0 can only be set or reset when DP-V1 support and Diagnostic Alarm support are enabled with the DP-Master Configuration Tool.

→ For details on BFM #35, refer to Section 6.16

→ For details on BFM #38, refer to Section 6.19

→ For details on enabling DP-V1 support, refer to Subsection 7.1.1

6.36 Diagnostic/Alarm Immediate Send Flag [BFM #1300 Bit0]

BFM Access : Read / Write

Data consistency is necessary for transferring Diagnostic/Alarm(Status) Data.

To send the Diagnostic/Alarm(Status) Data to the DP-Master, turn ON BFM#1300 Bit0. The 32DP transfers the content in BFM#1301 to BFM#1322 to the DP-Master.

The Diagnostic/Alarm Immediate Send Flag (BFM#1300 Bit0) turns OFF automatically according to the following settings:

- When the diagnostic data is transferred as Alarm Message (BFM#1299 Bit0 is OFF)
This flag turns OFF after the DP-Master acknowledges all of the Alarm Messages.
- When the diagnostic data is transferred as Status Message (BFM#1299 Bit0 is ON)
This flag turns OFF after the 32DP sends all of the diagnostic data.

When BFM#28 or BFM#29 ≠ 0, the 32DP immediately sends the Diagnostic/Alarm(Status) Data, regardless of this flag (BFM#1300 Bit0).

The 32DP allocates the content of BFM#28 and BFM#29 to BFM#1307 and BFM#1308.

6.37 Diagnostic/Alarm (Status) Data Area

The Subsections below detail the Data Storage Area of the Diagnostic/Alarm (Status) Message. Data consistency is necessary for the user-diagnostic and alarm (status) messages.

BFM No.	Name	Description	Access
BFM #1301	Master Address	This BFM shows the DP-Master address. → For details, refer to Subsection 6.37.1	Read Only
BFM #1302	Ident Number	This BFM shows the DP-Master Ident number. → For details, refer to Subsection 6.37.2	Read Only
BFM #1303	Block Length	This BFM shows the diagnostic alarm data length. ExtDiagData [0]	Read Only
BFM #1304	Alarm / Status Type	This BFM shows the Alarm/Status type. ExtDiagData [1] → For details, refer to Subsection 6.37.4	Read Only
BFM #1305	Slot Number	This BFM shows the Slot Number. The 32DP's Slot Number is always "0". ExtDiagData [2] → For details, refer to Subsection 6.37.5	Read Only
BFM #1306	Specifier	This BFM shows the Alarm/Status specifier, Additional Acknowledge, and Sequence Number. ExtDiagData [3] → For details, refer to Subsection 6.37.6	Read Only
BFM #1307	Extended Alarm Data	This BFM shows the Extended alarm data. ExtDiagData [4, 5] → For details, refer to Subsection 6.37.7	Read Only
BFM #1308	Extended Alarm Data	This BFM shows the Extended alarm data. ExtDiagData [6, 7] → For details, refer to Subsection 6.37.8	Read Only
BFM #1309 to #1322	Extended Diagnostic/Alarm (Status) Data Area	This is the user-defined data storage area for the user diagnostic data. A maximum of 28 Bytes can be stored. ExtDiagData [8 to 35]	Read / Write

6.37.1 Master Address [BFM #1301]

BFM Access : Read Only

After the DP Network configuration, this BFM shows the DP-Master address.

6.37.2 ID Number [BFM #1302]

BFM Access : Read Only

The identification mark uniquely identifies each DP-Master.

6.37.3 Block Length [BFM # 1303]

BFM Access : Read Only

This BFM shows the diagnostic alarm data length.

6.37.4 Alarm/Status Type [BFM #1304]

BFM Access : Read Only

This BFM shows the Alarm/Status type as follows:
0x01 = Alarm Message
0x81 = Status Message

6.37.5 Slot Number [BFM #1305]

BFM Access : Read Only

This BFM comes from the PROFIBUS DP Specification, displaying the number of the special function blocks sending the alarm.
The 32DP's value here is always "0".

6.37.6 Specifier [BFM #1306]

BFM Access : Read Only

Bit No.	Description
Bit 0 Bit 1	The Alarm/Status specifier defines the message status *1 0x00 : No further distinction 0x01 : The error occurred and the slot number (BFM#1305) has an error 0x02 : The error disappeared and the slot number (BFM#1305) has no error 0x03 : The error disappeared and the slot number (BFM#1305) has an error
Bit 2	Additional Acknowledge ON when the message needs additional acknowledging *2
Bit 3 to 7	Sequence Number This BFM shows the sequence number of the message The sequence number range lies from 0 to 31

*1. This specifier comes from the PROFIBUS DP Specification, displaying the message status.
The 32DP's value here is always "0X00."

*2. This also comes from the PROFIBUS DP Specification, displaying the additional acknowledge handling.
The 32DP's value here is always "0".

6.37.7 Extended Alarm Data [BFM #1307]

BFM Access : Read Only

The 32DP allocates the content of BFM#28 here.

6.37.8 Extended Alarm Data [BFM #1308]

BFM Access : Read Only

The 32DP allocates the content of BFM#29 here.

6.37.9 Extended Diagnostic/Alarm(Status) Data Area [BFM #1309 to #1322]

BFM Access : Read / Write

This is the user-defined data storage area for the user diagnostic data. A maximum of 28 Bytes can be stored.

7. Parameter Setting and Network Configuration [GX Configurator-DP]

STARTUP AND MAINTENANCE PRECAUTIONS



WARNING

- Do not touch any terminal while the PLC's power is on.
Doing so may cause electric shock or malfunctions.
- Before cleaning or retightening terminals, externally cut off all phases of the power supply.
Failure to do so may cause electric shock.
- Before modifying or disrupting the program in operation or running the PLC, carefully read through this manual and the associated manuals and ensure the safety of the operation.
An operation error may damage the machinery or cause accidents.

STARTUP AND MAINTENANCE PRECAUTIONS



CAUTION

- Do not disassemble or modify the unit.
Doing so may cause fire, equipment failures, or malfunctions.
* For repair, contact your local Mitsubishi Electric representative.
- Do not drop the product or expose the product to strong impacts, as doing so may cause product damage.
- Turn off the power to the PLC before attaching or detaching the peripheral devices.
Failure to do so may cause equipment failures or malfunctions.

To set the parameters and configure the DP network, use GX Configurator-DP (Ver.7.00A or later).

→ For operation details on GX Configurator-DP, refer to the GX Configurator-DP Software Manual

→ For details on DP-Master setting procedures, refer to the respective DP-Master manual

→ For examples on setting parameters and configurations, refer to Chapter 8

Note

Module type

Select the appropriate module type in the "Network Setup" dialog box.

Operation mode

The FX3U-64DP-M PROFIBUS Master Module has 2 operation modes for cyclic communication.

- The Normal Service Mode exchanges a maximum of 32Byte/Slave.
- The Extended Service Mode exchanges a maximum of 244Byte/slave.

→ For the MELSEC PROFIBUS Operation Modes, refer to the respective DP-Master manual

1

Introduction

2

Specifications

3

Installation

4

Wiring

5

Comm. Outline on
PROFIBUS-DP
Network

6

Buffer Memory
Allocation

7

Parameter Setting
and Network
Configuration

8

Example
Program

9

Diagnostics

7.1 Slave Parameter Settings

The slave parameters for the 32DP must be set using the DP-Master Configuration Tool. This section describes the available parameters that are available with GX Configurator-DP.

→ For details on the "Slave Parameter Settings" dialog box, refer to the GX Configurator-DP Software Manual.

7.1.1 Slave Properties

Set the following parameters in the Slave Properties section of the "Slave Parameter Settings" dialog box within GX Configurator-DP.

→ For details on the "Slave Parameter Settings" dialog box, refer to the GX Configurator-DP Software Manual.

Parameter	Description	Default/Setting Range
Name	Name of the DP-Slave	Default: Slave_Nr_001
FDL address	This item defines the slave address	Default: 1 Range : 0 to 125
Watchdog	Check off to enable the watchdog control for the DP-Slave The DP-Slave monitors if the DP-Master completes the communication process within the preset watchdog time, and if the process exceeds the watchdog time, BFM #29 Bit 8 turns ON	Default: Not Checked
Slave Watchdog Time	Here, users need to set the watchdog time interval of the DP-Slave when the watchdog functionality is enabled. The Watchdog Time must be longer than the max. PROFIBUS Cycle Time. → For details on PROFIBUS Cycle Time, refer to the respective DP-Master Manual	Range: 1 to 65025 [10ms]
min T_sdr	This is the minimum response time for a DP slave to send the response frames to the DP master. Do not change this value.	Default : 11 Range : 1 to 255
Group Identification Number	Check off to allocate the DP-Slave to a group or a set of groups. The DP-Slaves in the same group operate synchronously	-
Slave is active	Check off for the master to determine the presence of the specified DP-Slave This helps users sort out the physical network connections	Default : Checked off
Sync (Output)	Check off set the output data ready for the SYNC mode	Default : Not Checked
Freeze (Input)	Check off to set the input data ready for the FREEZE mode	Default : Not Checked
Swap I/O Bytes in Master	Check off to swap the byte order for a PROFIBUS DP Module having the reversed-byte word format	Default : Not Checked
DP V1/V2 Slave Parameters	Click this button to open the <DP V1/V2 Slave Parameters> dialog box. Use the options to enable/disable DP-V1 Support and to set support for Diagnostic Alarm data. The default setting for "DP V1 support enabled" is "Not checked"	-

7.1.2 Extended User Parameters

Use the "User Param." button from the "Slave Parameter Settings" dialog box in GX Configurator-DP to enable or disable the swap byte order. The default setting is set to "disable." The "User Param." button opens the "Extended User Parameters" dialog box and is applicable for the Byte Swap of cyclic/acyclic I/O-Data.

→ For details on the "Slave Parameter Settings" dialog box, refer to the GX Configurator-DP Software Manual.

7.1.3 Slave Modules

Use the "Select Modules" button from the "Slave Parameter Settings" dialog box in GX Configurator-DP to define the combinations of I/O data sets for the Slave. GX Configurator-DP automatically restricts the number of available options.

→ For details on the "Slave Parameter Settings" dialog box, refer to the GX Configurator-DP Software Manual.

7.2 Network Configuration

Configure the PROFIBUS-DP network in the "graphical network editor" window with the GX Configurator-DP software.

→ For operation details, refer to GX Configurator-DP Software Manual.

1

Introduction

2

Specifications

3

Installation

4

Wiring

5

Comm. Outline on
PROFIBUS-DP
Network

6

Buffer Memory
Allocation

7

Parameter Setting
and Network
Configuration

8

Example
Program

9

Diagnostics

8. Example Program

STARTUP AND MAINTENANCE PRECAUTIONS



WARNING

- Do not touch any terminal while the PLC's power is on. Doing so may cause electric shock or malfunctions.
- Before cleaning or retightening terminals, externally cut off all phases of the power supply. Failure to do so may cause electric shock.
- Before modifying or disrupting the program in operation or running the PLC, carefully read through this manual and the associated manuals and ensure the safety of the operation. An operation error may damage the machinery or cause accidents.

STARTUP AND MAINTENANCE PRECAUTIONS



CAUTION

- Do not disassemble or modify the unit. Doing so may cause fire, equipment failures, or malfunctions. * For repair, contact your local Mitsubishi Electric representative.
- Do not drop the product or expose the product to strong impacts, as doing so may cause product damage.
- Turn off the power to the PLC before attaching or detaching the peripheral devices. Failure to do so may cause equipment failures or malfunctions.

8.1 Example Program

8.1.1 System Configuration

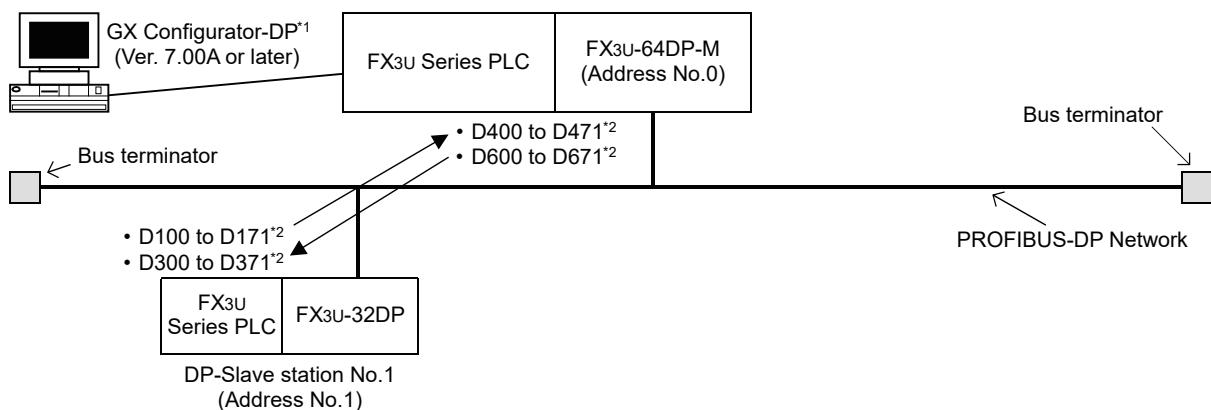

- *1. When configuring a system without a Mitsubishi PROFIBUS Master, separate software must be used.
*2. The range of data registers is different for acyclic communication.
→ For a program example on Acyclic Communication, refer to Section 8.1.6

8.1.2 Contents of Operation

- D100 to D171 of the FX3U PLC on DP-Slave Station No.1 are written to the 32DP BFM and sent to the DP-Master's BFM on the PROFIBUS DP Network. The data is then transferred from the 64DP-Master's BFM to enter D400 to D471 on the FX3U PLC Master. In a similar fashion, D600 to D671 from the Master Station is sent to D300 to D371 on the Slave Station.
- User Diagnostic and Alarm (or Status) data is sent from D20 to D33 of the 32DP PLC to the DP-Master.

8.1.3 Setting Network Configuration and Parameter for Example Program

When setting the network configuration and parameters for the example program, use GX Configurator-DP Ver. 7.00A or later.

→ For operation of GX Configurator-DP, refer to the GX Configurator-DP Software Manual

Point

- 1) Module type
Select FX CPU Series and set the MELSEC Device to "FX3U-64DP-M (PROFIBUS DP V1 Master)" on the "Network Setup" dialog box.
- 2) Download the project.
When completing the project, download it to the 64DP-M.

1 Master Parameter Settings

Set the master parameter settings as follows in the "Master Settings" dialog box.

→ For details, refer to the GX Configurator-DP Software Manual

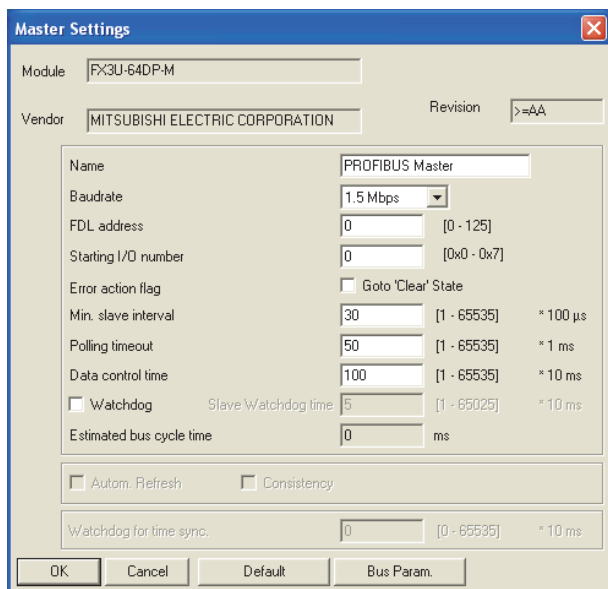

2 Bus Parameter Settings

Set the bus parameter settings as follows in the "Bus Parameter" dialog box.

→ For details, refer to the GX Configurator-DP Software Manual

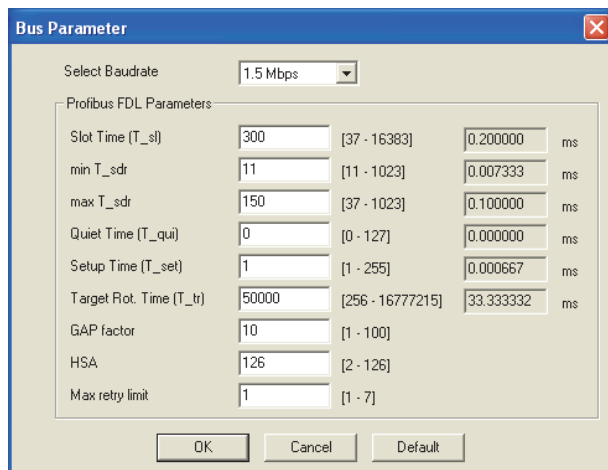

3 Network Configuration

Create the network configuration as follows using the "graphical network editor" window.

→ For operation details, refer to the **GX Configurator-DP Software Manual**

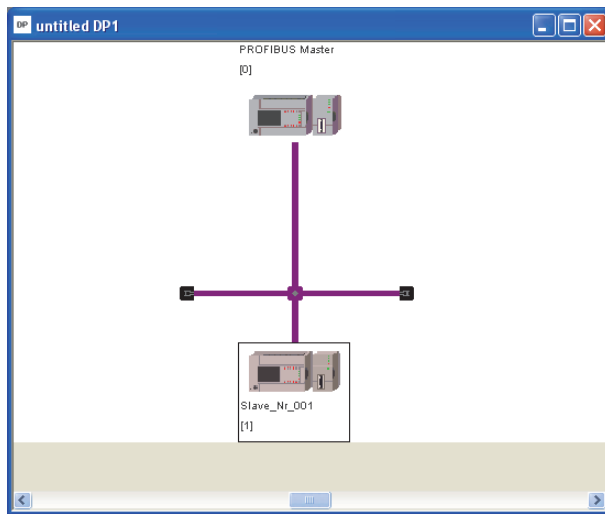

4 FX3U-32DP Setting

→ For details on the **Slave Parameters and Module Configuration settings**, refer to the **GX Configurator-DP Software Manual**

1. Slave Parameter Settings

Set the slave parameter settings for the FX3U-32DP as follows in the "Slave Parameter Settings" dialog box.

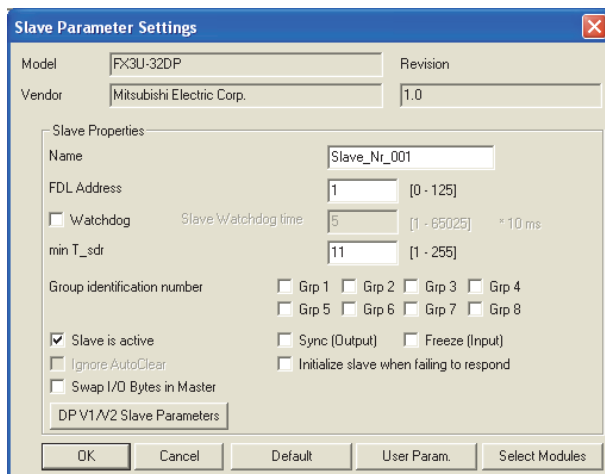

2. DP V1/V2 Slave Parameter Settings

Set the DP V1/V2 Slave Parameter Settings for the FX3U-32DP as follows in the "DP V1/V2 Slave Parameters" dialog box.

→ For details, refer to **Subsection 7.1.1**

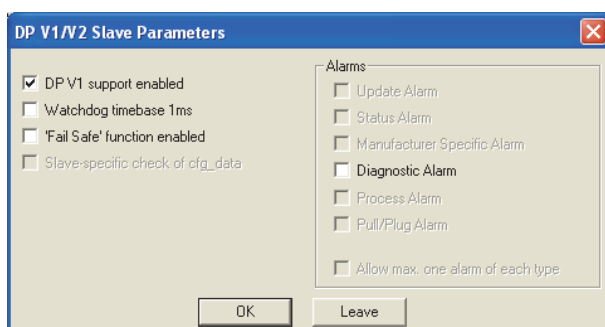

3. Module Configuration Settings

Set the Module Configuration for the FX3U-32DP as follows in the "Slave Modules" dialog box.

→ For details, refer to Subsection 7.1.3

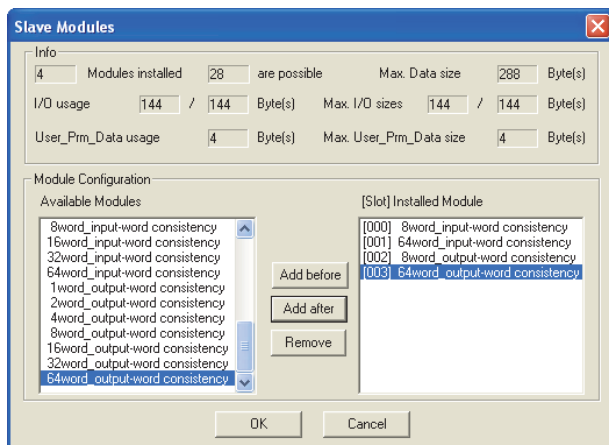

8.1.4 Example Program for Cyclic Communication using GX Developer

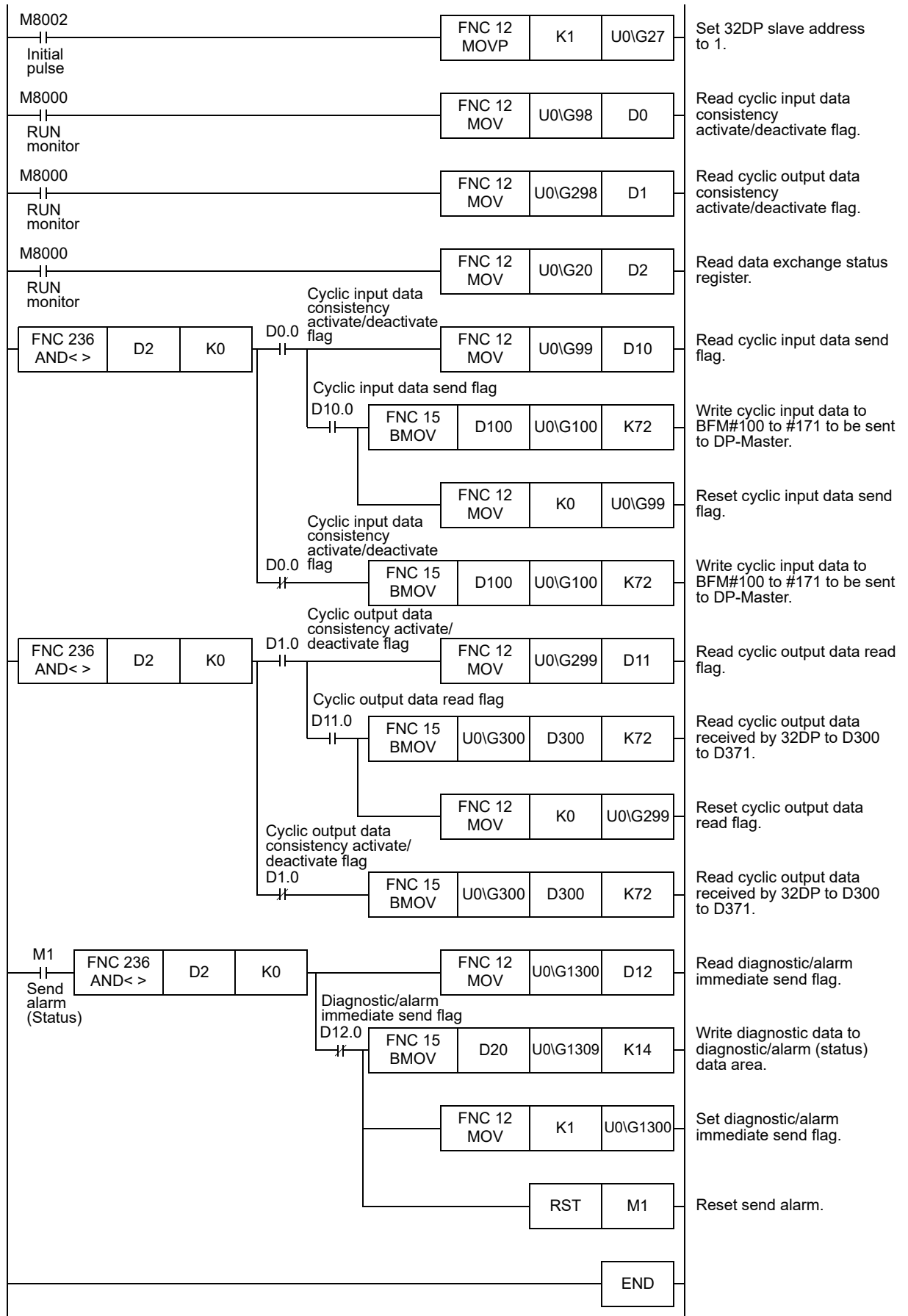

8.1.5 Example Program for Cyclic Communication using GX IEC Developer (Ver. 7.00 or later)

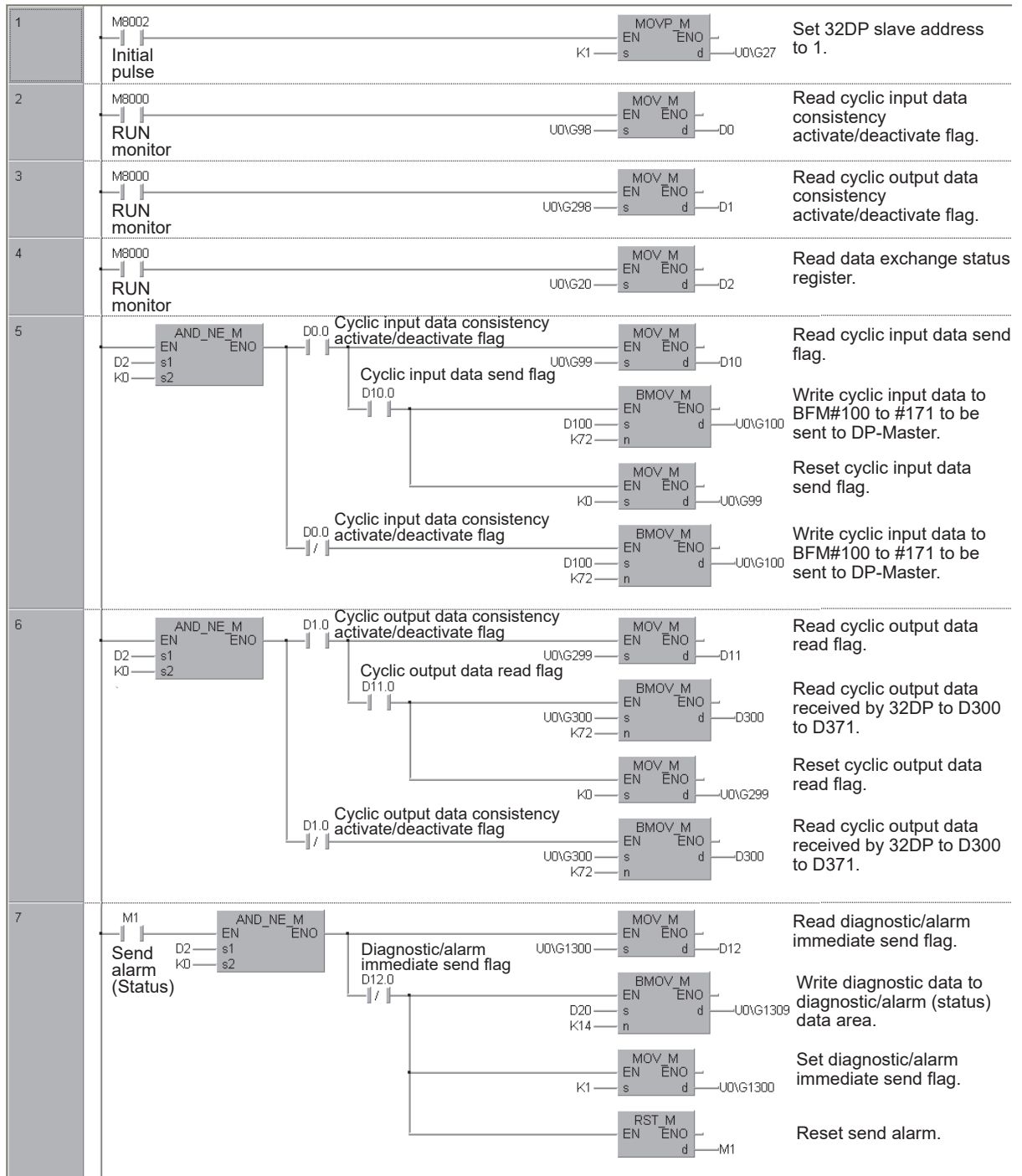

1

Introduction

2

Specifications

3

Installation

4

Wiring

5

Comm. Outline on PROFIBUS-DP Network

6

Buffer Memory Allocation

7

Parameter Setting and Network Configuration

8

Example Program

9

Diagnostics

8.1.6 Example Program for Acyclic Communication using GX Developer

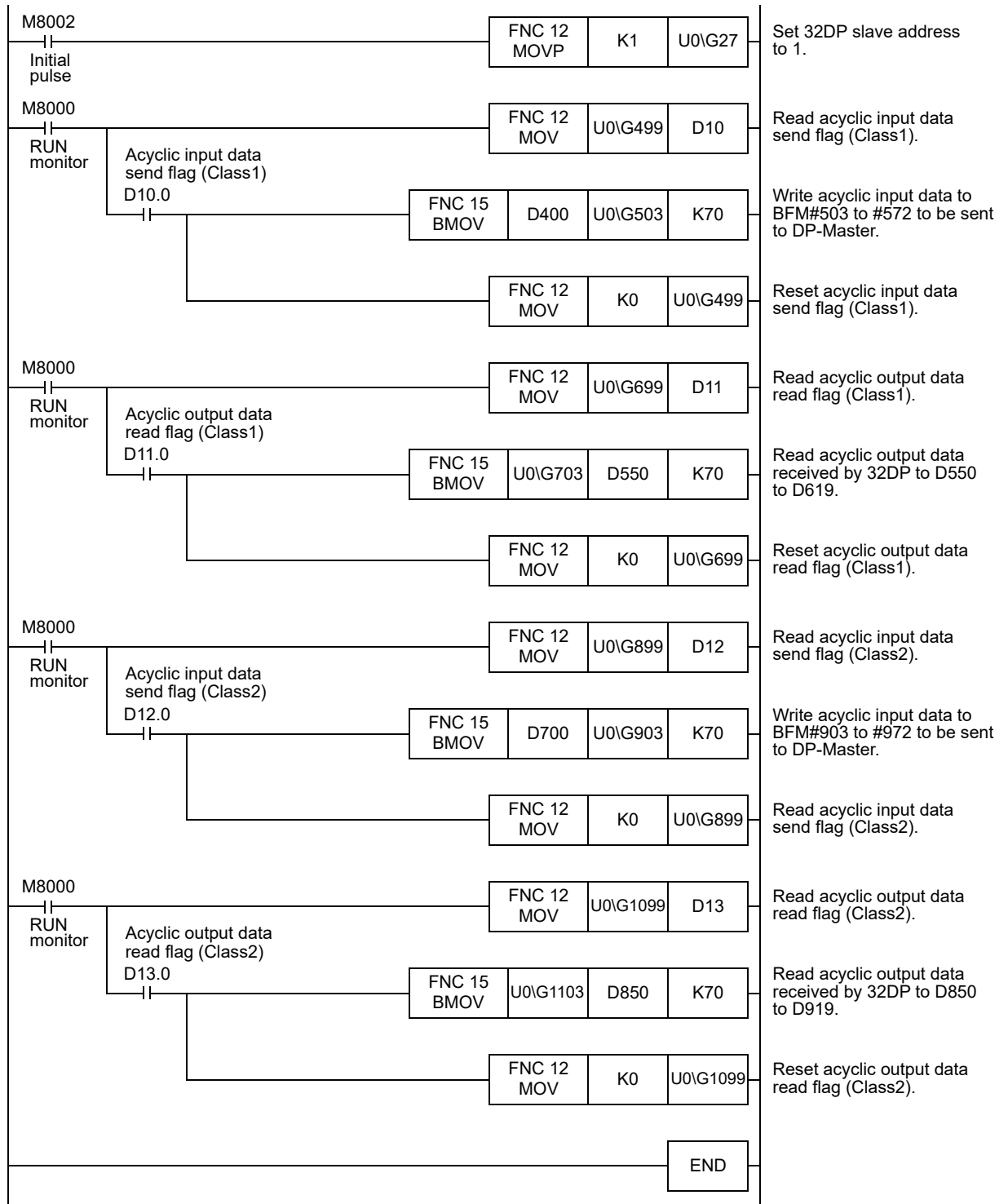

8.1.7 Example Program for Acyclic Communication using GX IEC Developer (Ver. 7.00 or later)

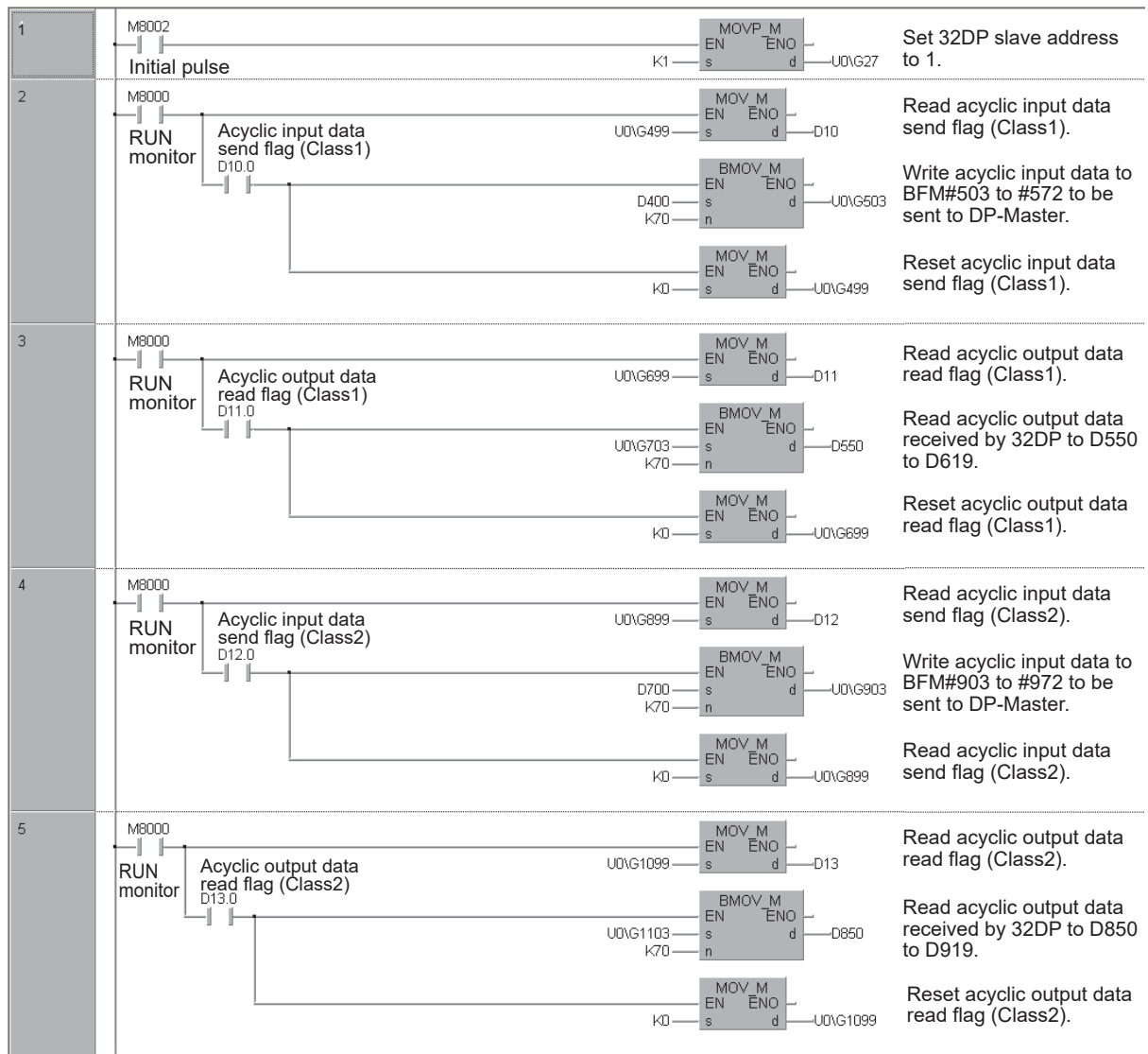

1

Introduction

2

Specifications

3

Installation

4

Wiring

5

Comm. Outline on PROFIBUS-DP Network

6

Buffer Memory Allocation

7

Parameter Setting and Network Configuration

8

Example Program

9

Diagnostics

9. Diagnostics

STARTUP AND MAINTENANCE PRECAUTIONS



WARNING

- Do not touch any terminal while the PLC's power is on.
Doing so may cause electric shock or malfunctions.
- Before cleaning or retightening terminals, externally cut off all phases of the power supply.
Failure to do so may cause electric shock.
- Before modifying or disrupting the program in operation or running the PLC, carefully read through this manual and the associated manuals and ensure the safety of the operation.
An operation error may damage the machinery or cause accidents.

STARTUP AND MAINTENANCE PRECAUTIONS



CAUTION

- Do not disassemble or modify the unit.
Doing so may cause fire, equipment failures, or malfunctions.
* For repair, contact your local Mitsubishi Electric representative.
- Do not drop the product or expose the product to strong impacts, as doing so may cause product damage.
- Turn off the power to the PLC before attaching or detaching the peripheral devices.
Failure to do so may cause equipment failures or malfunctions.

9.1 Check LEDs

Check the POWER, RUN and ERROR LED status.

1. POWER LED : Green

LED State	Description
ON	The connected PLC supplies power to the 32DP correctly
OFF	<p>Incorrect power supply from the PLC to the 32DP due to an unsecured cable connection</p> <ul style="list-style-type: none"> • Check the extension cable connection to the PLC • Check the power supply of the FX3G/FX3GC^{*1}/FX3U/FX3UC^{*1}/FX5U^{*2}/FX5UC^{*2} PLC <ul style="list-style-type: none"> → For FX3G Series PLC, refer to FX3G Hardware Edition → For FX3GC Series PLC, refer to FX3GC Hardware Edition → For FX3U Series PLC, refer to FX3U Hardware Edition → For FX3UC Series PLC, refer to FX3UC Hardware Edition → For FX5U PLC and FX5UC PLC, refer to MELSEC iQ-F FX5S/FX5UJ/FX5U/FX5UC User's Manual (Hardware) → For the power supply specifications for the 32DP, refer to Section 2.2

*1. An FX2NC-CNV-IF or FX3UC-1PS-5V is necessary to connect to the 32DP with the FX3GC/FX3UC Series PLC.
However, the 32DP cannot be connected to the FX3UC-32MT-LT(-2).

*2. An FX5-CNV-BUS or FX5-CNV-BUSC is necessary to connect to the 32DP with the FX5U/FX5UC PLC.

2. FROM/TO : Green

LED State	Description
ON	Constant FROM/TO access within 200ms intervals
OFF	No FROM/TO access within 200ms

3. RUN LED : Green

LED State	Description
ON	The 32DP is in cyclic data exchange mode
OFF	The 32DP is not in cyclic data exchange mode
Flashing	The DP-Master is in clear mode or the 32DP is in fail-safe mode

4. DIA LED : Red

LED State	Description
ON	Hardware error in the 32DP
OFF	Normal Operation without errors
Flashing	A User-Diagnostic Message or a DP-V1 Alarm/Status Message is left unread

→ For Error details, refer to Section 9.2

5. TOKEN LED : Green

LED State	Description
ON	The 32DP established a connection with the DP-Master at an appropriate transmission speed A Class2 Master can access the 32DP now
OFF	The 32DP has not established a connection at any transmission speed

Note

A consistency error also occurs when users monitor the 32DP BFM's in data consistency mode with programming Software (i. e. GX Developer).

9.2 Checking Errors

The following BFM has read/write access. Check the following BFM status to determine the error cause.

1. General Error [BFM #29 Bit 0]

This bit is set to ON if one or more of BFM#29's Bit1, 8-13 is ON. The 32DP attempts to send diagnostic data from BFM#28 and BFM#29 to the DP-Master while suspending normal data exchange when the General Error bit (BFM#29 Bit0) is ON.

2. PLC in STOP Mode [BFM #29 Bit 1]

This bit is set to ON if the connected PLC is in STOP Mode.

3. Extended-UserAlarm/Diagnostic Data Not Yet Sent Flag [BFM #29 Bit 2]

This bit is set to ON if the Extended-UserAlarm/Diagnostic Data has not yet been sent, or if it has not yet been acknowledged by the DP-master. This flag functions similar to the "Diagnostics Status Flag" in BFM#25 Bit2.

4. Hardware Error [BFM #29 Bit 3]

This bit is set to ON if an error occurs while initializing the 32DP or if a hardware error occurs during RUN. While this bit is ON, the 32DP halts communication with the DP-Master and only FROM instructions can operate for error checking.

5. EEPROM Error [BFM #29 Bit 4]

This bit is set to ON if an error occurs while initializing the 32DP EEPROM or if the slave address data in the EEPROM becomes corrupt. The EEPROM data may be damaged or destroyed. This bit corresponds directly with BFM#29 Bit3.

6. Consistency Handling Error Flags [BFM #29 Bit 5]

This bit is set to ON when the 32DP detects an error with data consistency handling. Further information is provided in BFM#37 for the type of consistency error. Resetting this bit will also reset BFM#37.

→ For details on the Consistency Handling Error Flags BFM#37, refer to Section 6.18

7. Setting Error Flag [BFM #29 Bit 6]

This bit is set to ON if an invalid setting is written to one of the 32DP's BFM addresses. Further information is provided in BFM#38 for the type of error. Resetting this bit will also reset BFM#38.

→ For details on the Setting Error Flag BFM#38, refer to Section 6.19

8. Watchdog DP Timeout Flag [BFM #29 Bit 8]

This bit is set to ON if the DP-Watchdog timer expires in the DP-control state. No requests were made to the DP-Master within the projected watchdog time. Causes may include a faulty PROFIBUS cable connection.

9. Acyclic Communication Error [BFM #29 Bit 9]

This bit is set to ON when an error occurs in (DP-V1) acyclic communication. Further information is provided in BFM#35 for the type of acyclic communication error. Resetting this bit will also reset BFM#35.

→ For details on the DP-V1 Communication Parameter BFM#35, refer to Section 6.16 [BFM #29 Bit 10]

10. Configuration Error [BFM #29 Bit 10]

This bit is set to ON if invalid configuration data is received from the DP-Master.

11. Parameter Error [BFM #29 Bit 11]

This bit is set to ON if invalid parameter data is received from the DP-Master.

12. Slave Address Change Error [BFM #29 Bit 12]

This bit turns ON if the user sets the 32DP slave address to a value greater than 126 in BFM#27 or if the slave address is set to greater than 125 when setting via SSA-telegram. This bit automatically resets itself when the 32DP slave address is set correctly via BFM or SSA.

→ For details on setting the Slave Address BFM#27, refer to Section 6.10

13. Slave "Reset No Address Change" Error [BFM #29 Bit 13]

This bit turns ON when the 32DP detects an error due to resetting the Address Change Impossible Flag (BFM#25 Bit8) while the slave is in Data Exchange mode, or when the Address Change Impossible Flag (BFM#25 Bit8) is reset while the write access to BFM#25 Bit8 is disabled.

Warranty

Please confirm the following product warranty details before using this product.

1. Gratis Warranty Term and Gratis Warranty Range

If any faults or defects (hereinafter "Failure") found to be the responsibility of Mitsubishi occurs during use of the product within the gratis warranty term, the product shall be repaired at no cost via the sales representative or Mitsubishi Service Company. However, if repairs are required onsite at domestic or overseas location, expenses to send an engineer will be solely at the customer's discretion. Mitsubishi shall not be held responsible for any re-commissioning, maintenance, or testing on-site that involves replacement of the failed module.

[Gratis Warranty Term]

The gratis warranty term of the product shall be for one year after the date of purchase or delivery to a designated place. Note that after manufacture and shipment from Mitsubishi, the maximum distribution period shall be six (6) months, and the longest gratis warranty term after manufacturing shall be eighteen (18) months. The gratis warranty term of repair parts shall not exceed the gratis warranty term before repairs.

[Gratis Warranty Range]

- (1) The range shall be limited to normal use within the usage state, usage methods and usage environment, etc., which follow the conditions and precautions, etc., given in the instruction manual, user's manual and caution labels on the product.
- (2) Even within the gratis warranty term, repairs shall be charged for in the following cases.
 1. Failure occurring from inappropriate storage or handling, carelessness or negligence by the user. Failure caused by the user's hardware or software design.
 2. Failure caused by unapproved modifications, etc., to the product by the user.
 3. When the Mitsubishi product is assembled into a user's device, Failure that could have been avoided if functions or structures, judged as necessary in the legal safety measures the user's device is subject to or as necessary by industry standards, had been provided.
 4. Failure that could have been avoided if consumable parts (battery, backlight, fuse, etc.) designated in the instruction manual had been correctly serviced or replaced.
 5. Relay failure or output contact failure caused by usage beyond the specified Life of contact (cycles).
 6. Failure caused by external irresistible forces such as fires or abnormal voltages, and failure caused by force majeure such as earthquakes, lightning, wind and water damage.
 7. Failure caused by reasons unpredictable by scientific technology standards at time of shipment from Mitsubishi.
 8. Any other failure found not to be the responsibility of Mitsubishi or that admitted not to be so by the user.

2. Onerous repair term after discontinuation of production

- (1) Mitsubishi shall accept onerous product repairs for seven (7) years after production of the product is discontinued.

Discontinuation of production shall be notified with Mitsubishi Technical Bulletins, etc.

- (2) Product supply (including repair parts) is not available after production is discontinued.

3. Overseas service

Overseas, repairs shall be accepted by Mitsubishi's local overseas FA Center. Note that the repair conditions at each FA Center may differ.

4. Exclusion of loss in opportunity and secondary loss from warranty liability

Regardless of the gratis warranty term, Mitsubishi shall not be liable for compensation to:

- (1) Damages caused by any cause found not to be the responsibility of Mitsubishi.
- (2) Loss in opportunity, lost profits incurred to the user by Failures of Mitsubishi products.
- (3) Special damages and secondary damages whether foreseeable or not, compensation for accidents, and compensation for damages to products other than Mitsubishi products.
- (4) Replacement by the user, maintenance of on-site equipment, start-up test run and other tasks.

5. Changes in product specifications

The specifications given in the catalogs, manuals or technical documents are subject to change without prior notice.

6. Product application

- (1) In using the Mitsubishi MELSEC programmable logic controller, the usage conditions shall be that the application will not lead to a major accident even if any problem or fault should occur in the programmable logic controller device, and that backup and fail-safe functions are systematically provided outside of the device for any problem or fault.

- (2) The Mitsubishi programmable logic controller has been designed and manufactured for applications in general industries, etc. Thus, applications in which the public could be affected such as in nuclear power plants and other power plants operated by respective power companies, and applications in which a special quality assurance system is required, such as for Railway companies or Public service purposes shall be excluded from the programmable logic controller applications.

In addition, applications in which human life or property that could be greatly affected, such as in aircraft, medical applications, incineration and fuel devices, manned transportation, equipment for recreation and amusement, and safety devices, shall also be excluded from the programmable logic controller range of applications.

However, in certain cases, some applications may be possible, providing the user consults their local Mitsubishi representative outlining the special requirements of the project, and providing that all parties concerned agree to the special circumstances, solely at the users discretion.

Revised History

Date	Revision	Description
3/2007	A	First Edition
9/2007	B	Changed BFM Descriptions [Section 6.35 and 6.37]
2/2011	C	<ul style="list-style-type: none"> • The FX3G/FX3UC Series was added. [FX3UC-32MT-LT(-2) is excluded.] • The notation change of "Compliance with EC directive." • The manual is added to Associated Manuals. • Errors are corrected.
4/2015	D	<ul style="list-style-type: none"> • A part of the cover design is changed.
11/2016	E	<ul style="list-style-type: none"> • The FX3GC Series was added. • The FX5U/FX5UC was added.
3/2019	F	<ul style="list-style-type: none"> • Errors are corrected.
10/2022	G	<ul style="list-style-type: none"> • Compliance with UKCA marking is added. • The manual name for the User's Manual (Hardware) is changed.

Japanese manual number: SH-081948-B

USER'S MANUAL

FX3U-32DP PROFIBUS-DP Interface Block

MITSUBISHI ELECTRIC CORPORATION

HEAD OFFICE : TOKYO BUILDING, 2-7-3 MARUNOUCHI, CHIYODA-KU, TOKYO 100-8310, JAPAN

MODEL	FX3U-32DP-U-E
MODEL CODE	09R633