

Mitsubishi Electric Corporation  
 2-7-3 Marunouchi, Chiyoda-ku, Tokyo, Japan  
 Mitsubishi Electric Europe BV  
 Gothaer strasse 8, 40880 Ratingen, Germany  
 All rights reserved • Specified product properties and technical data do not represent a guarantee declaration.

MODEL	WS-IO-U-HW
MODEL CODE	13J201
IB(NA)-0800444-E(1112)MEE	

© 2009 MITSUBISHI ELECTRIC CORPORATION

**Precautions regarding warranty and specifications**

MELSEC-WS series products were jointly developed and manufactured by Mitsubishi and SICK AG, Industrial Safety Systems, in Germany. Note that there are some precautions regarding warranty and specifications of MELSEC-WS series products.

<Warranty>

- The gratis warranty term of the product shall be for one (1) year after the date of delivery or for eighteen (18) months after manufacturing, whichever is less.
- The onerous repair term after discontinuation of production shall be for four (4) years.
- Mitsubishi shall mainly replace the product that needs a repair.
- It may take some time to respond to the problem or repair the product depending on the condition and timing.

<Specifications>

- General specifications of the products differ.

	MELSEC-WS	MELSEC-Q	MELSEC-QS
Operating ambient temperature	-25 to 55°C*1	0 to 55°C	0 to 55°C
Operating ambient humidity	10 to 95%RH	5 to 95%RH	5 to 95%RH
Storage ambient temperature	-25 to 70°C	-25 to 75°C	-40 to 75°C
Storage ambient humidity	10 to 95%RH	5 to 95%RH	5 to 95%RH

\*1: When the WS0-GCC100202 is included in the system, operating ambient temperature will be 0 to 55°C.

- EMC standards that are applicable to the products differ.

	MELSEC-WS	MELSEC-Q, MELSEC-QS
EMC standards	EN 61000-6-2, EN 55011	EN 61131-2

**1 About this document**

This document is the original manual.

**1.1 Documentations for the MELSEC-WS system**

This manual describes the mounting of the safety I/O modules (WS0-XTIO and WS0-XTDI) of a MELSEC-WS safety controller.

Mounting of the MELSEC-WS CPU modules (WS0-CPU0 and WS0-CPU1), network modules (WS0-GETH and WS0-GCC1) and the relay output module (WS0-4RO) is described in separate manuals.

The installation, configuration and commissioning of the MELSEC-WS safety controller are described in the "Safety Controller User's Manual" and "Safety Controller Setting and Monitoring Tool Operating Manual".

Title	Number
Safety Controller User's Manual	WS-CPU-U-E (13JZ32)
Safety Controller Ethernet Interface User's Manual	WS-ET-U-E (13JZ33)
Safety Controller CC-Link Interface User's Manual	WS-CC-U-E (13JZ45)
Safety Controller Setting and Monitoring Tool Operating Manual	SW1DNNWS0ADR-B-O-E (13JU67)

**1.2 Function of this document**

This manual instructs the technical staff of the machine manufacturer and/or of the machine operator on the safe mounting of the safety I/O module of the MELSEC-WS safety controller.

In addition mounting protective devices also requires specific technical skills which are not detailed in this documentation.

This manual does not provide manuals for operating the machine in which the safety controller is, or will be, integrated. Information of this kind will be found in the manuals for the machine.

**2 On safety**

This chapter deals with your own safety and the safety of the equipment operators.

- Please read this chapter carefully before beginning with the installation.

**2.1 Qualified safety personnel**

The MELSEC-WS safety controller may only be installed by qualified safety personnel.

Qualified safety personnel are defined as persons who ...

- have undergone the appropriate technical training **and**
- who have been instructed by the responsible machine operator in the operation of the machine and the current valid safety guidelines **and**
- have access to the MELSEC-WS manuals and have read and familiarized themselves with them **and**
- have access to the manuals for the protective devices (e.g. light curtains) connected to the safety controller and have read and familiarized themselves with them.

**2.2 Applications of the device**

The MELSEC-WS safety controller is a configurable controller for safety applications. It can be used

- in accordance with IEC 61508 to SIL 3
- in accordance with IEC 62061 to SILCL 3
- in accordance with EN/ISO 13849-1 up to Performance Level e

The degree of safety actually attained depends on the external circuit, the realization of the wiring, the parameter configuration, the choice of the pick-ups and their location at the machine.

Opto-electronic and tactile safety sensors (e.g. light curtains, laser scanners, safety switches, sensors, emergency-stop buttons) are connected to the safety controller and are linked logically. The corresponding actuators of the machines or systems can be switched off safely via the switching outputs of the safety controller.

**2.3 Correct use**



**The MELSEC-WS safety controller fulfils the requirements of Class A (industrial applications) in accordance with the "Interference emission" basic specifications!**

The MELSEC-WS safety controller is therefore only suitable for use in an industrial environment and not for private use.

The MELSEC-WS safety controller may only be used within specific operating limits (voltage, temperature, etc., refer to the technical data and to the section "Application areas of the device"). It may only be used by specialist personnel and only at the machine at which it was mounted and initially commissioned by qualified personnel in accordance with the "Safety Controller User's Manual".

The modules of the MELSEC-WS safety controller conform to Class A, Group 1, in accordance with EN 55011. Group 1 encompasses all the ISM devices in which intentionally generated and/or used conductor-bound RF energy that is required for the inner function of the device itself occurs. Mitsubishi Electric Corporation accepts no claims for liability if the equipment is used in any other way or if modifications are made to the device, even in the context of mounting and installation.

UL/CSA applications:

- Use 60°C/75°C conductors.
- The terminal tightening torque must be 5-7 lbs in.
- To be used in a Pollution Degree 2 environment only.
- Memory plug and CPU module shall be supplied by an isolating power source protected by an UL248 fuse, rating 42.4VDC which is the maximum voltage requirements of UL508.
- The safety functions are not evaluated by UL. The approval is accomplished according to UL508, general use applications.

**2.4 General protective notes and protective measures**



**Observe the protective notes and measures!**

Please observe the following items in order to ensure proper use of the MELSEC-WS safety controller.

- When mounting, installing and using the MELSEC-WS safety controller, observe the standards and directives applicable in your country.
- The national/international rules and regulations apply to the installation, use and periodic technical inspection of the MELSEC-WS safety controller, in particular:
  - Machinery Directive 2006/42/EC
  - EMC Directive 2004/108/EC
  - Use of Work Equipment Directive 89/655/EC
  - Low-Voltage Directive 2006/95/EC
  - The work safety regulations/safety rules

- Manufacturers and owners of the machine on which a MELSEC-WS safety controller is used are responsible for obtaining and observing all applicable safety regulations and rules.
- It is imperative that the notices, in particular the test notice of the manual must be observed.
- The tests must be carried out by specialised personnel or specially qualified and authorised personnel and must be recorded and documented to ensure that the tests can be reconstructed and retraced at any time by third parties.

**2.5 Disposal**

Disposal of unusable or irreparable devices should always occur in accordance with the applicable country-specific waste-disposal regulations (e.g. European Waste Code 16 02 14).

**3 Conditions of use for the product**

- (1) Although MELCO has obtained the certification for Product's compliance to the international safety standards IEC 61508, EN 954-1/ISO 13849-1 from TUV Rheinland, this fact does not guarantee that Product will be free from any malfunction or failure. The user of this Product shall comply with any and all applicable safety standard, regulation or law and take appropriate safety measures for the system in which the Product is installed or used and shall take the second or third safety measures other than the Product. MELCO is not liable for damages that could have been prevented by compliance with any applicable safety standard, regulation or law.
- (2) MELCO prohibits the use of Products with or in any application involving, and MELCO shall not be liable for a default, a liability for defect warranty, a quality assurance, negligence or other tort and a product liability in these applications.
  - 1) power plants,
  - 2) trains, railway systems, airplanes, airline operations, other transportation systems,
  - 3) hospitals, medical care, dialysis and life support facilities or equipment,
  - 4) amusement equipments,
  - 5) incineration and fuel devices,
  - 6) handling of nuclear or hazardous materials or chemicals,
  - 7) mining and drilling,
  - 8) and other applications where the level of risk to human life, health or property are elevated.

**4 Product description**

**4.1 Description**

**4.1.1 Safety I/O combined module WS0-XTIO**

The WS0-XTIO module is an input/output extension with 8 safety inputs and 4 safety outputs. It fulfils the following tasks:

- Monitoring of the connected sensor equipment
- Passing on the input information to the CPU module
- Receiving the control signals from the CPU module and corresponding switching of the outputs
- Fast Shut Off

The WS0-XTIO module can only be used in combination with a CPU module (WS0-CPU0 or WS0-CPU1) (see the Safety Controller Setting and Monitoring Tool Operating Manual).

Simultaneous use of several WS0-XTIO modules is possible (a maximum total of 12 WS0-XTIO and WS0-XTDI).

Voltage for the internal logic and the test outputs is supplied from the memory plug via the FLEXBUS+ backplane bus.

Voltage for the WS0-XTIOs outputs Q1 ... Q4 must be supplied directly via A1/A2 on the respective module.

A WS0-XTIO has two test signal generators. Short circuits between test outputs X1 and X2 are recognised.

**4.1.2 Safety input module WS0-XTDI**

The WS0-XTDI module is the input extension with 8 safe inputs. It fulfils the following tasks:

- Monitoring of the connected sensor equipment
- Passing on the input information to the CPU module

The WS0-XTDI module can only be used in combination with a CPU module (WS0-CPU0 or WS0-CPU1) (see the Safety Controller Setting and Monitoring Tool Operating Manual).

Simultaneous use of several WS0-XTDI modules is possible (a maximum total of 12 WS0-XTIO and WS0-XTDI).

Voltage supply is effected via the FLEXBUS+ backplane bus.

A WS0-XTDI has two test signal generators. One test signal generator is responsible for the odd-numbered test pulse outputs X1, X3, X5 and X7, the other for the even-numbered test pulse outputs X2, X4, X6 and X8.



WS0-XTDI recognises short-circuits between odd-numbered (X1, X3, X5, X7) and even-numbered (X2, X4, X6, X8) test pulse outputs if the test gaps <4ms. If the test gaps ≥ 4ms, the short-circuits are not always recognize in every case. Short-circuits under the odd-numbered (X1, X3, X5, X7) test pulse outputs or under the even-numbered (X2, X4, X6, X8) test pulse outputs are not recognize.

- Take this into account for the wiring, e.g. by separate routing or sheathing lines.

**4.2 Display elements**

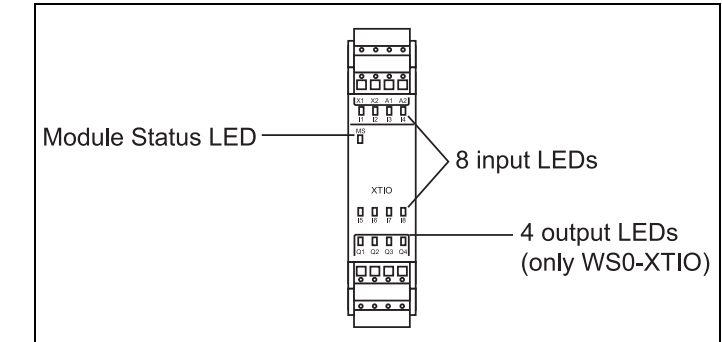

**4.2.1 Displays of the MS LED**

MS LED	Meaning
Off	Supply voltage lies outside range
Flashes red/green (1Hz)	Configuration required
Flashes green (1Hz)	System is in Stop state
Lights up green	System is in Run state
Flashes red (1Hz)	Recoverable external error
Lights up red	Critical error in the system, possibly in another module. Application is stopped. All outputs are switched off.

**4.2.2 Displays of the input/output LEDs**

Input LEDs (I1 ... I8) Output LEDs (Q1 ... Q4) (only WS0-XTIO)	Meaning
Off	Input/output is inactive.
Lights up green	Input/output is active.
Flashes green (1Hz) synchronous with the red MS LED	Input/output is inactive and there is a correctable error.
Flashes green (1Hz) alternating with the red MS LED	Input/output is active and there is a correctable error.

**4.3 Terminal assignment**

**4.3.1 Terminal assignment WS0-XTIO**

Module	Terminal	Assignment
	X1/X2	Test outputs 1 and 2
	I1 ... I4	Inputs 1 to 4
	A1	24V
	A2	GND
	I5 ... I8	Inputs 5 to 8
	Q1 ... Q4	Outputs 1 to 4

**4.3.2 Terminal assignment WS0-XTDI**

Module	Terminal	Assignment
	X1/X3	Test output 1 (test signal generator 1)
	X2/X4	Test output 2 (test signal generator 2)
	I1 ... I4	Inputs 1 to 4
	I5 ... I8	Inputs 5 to 8
	X5/X7	Test output 1 (test signal generator 1)
	X6/X8	Test output 2 (test signal generator 2)

## 5 Mounting/Dismantling

**ATTENTION** The MELSEC-WS safety controller is only suitable for mounting in a control cabinet with at least IP 54 degree of protection.

While supply voltage is applied, modules must not be plugged to nor be removed from the MELSEC-WS safety controller.

### 5.1 Mounting the modules

- In a MELSEC-WS safety controller, the WS0-CPU0 or WS0-CPU1 is positioned at the far left and the two optional network modules follow directly. Only then do the safety I/O modules follow. The WS0-4RO module has to be mounted at the far right.
- The modules are located in a 22.5mm wide modular system for 35mm DIN rails to IEC/EN 60715.
- The connection between the modules is effected by means of the plug connection integrated in the housing.
- Mount the modules in accordance with EN 50274
- Ensure that suitable ESD protective measures are also taken during mounting. Otherwise the FLEXBUS+ backplane bus may be damaged.
- Take suitable measures to ensure that foreign matter does not enter the connector openings, in particular that of the memory plug.

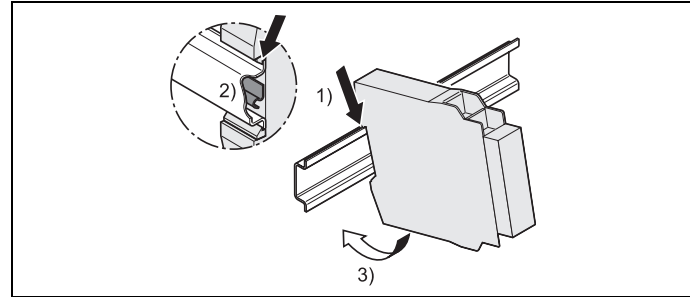

- Make sure that the voltage supply of the MELSEC-WS safety controller is switched off.
- Hang the device onto the DIN rail (1)).
- Ensure that the earthing spring contact is positioned correctly (2)). The earthing spring contact of the module must contact the DIN rail securely to allow electrical conductivity.
- Snap the module onto the DIN rail by pressing it lightly in the direction of the arrow (3)).

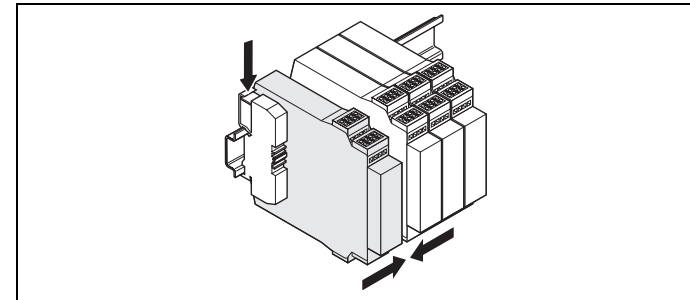

- If there are several modules, slide the modules together individually in the direction of the arrow until the side plug connection latches in.
- Install the end clips on the left and right.

### 5.2 Steps for dismantling the modules

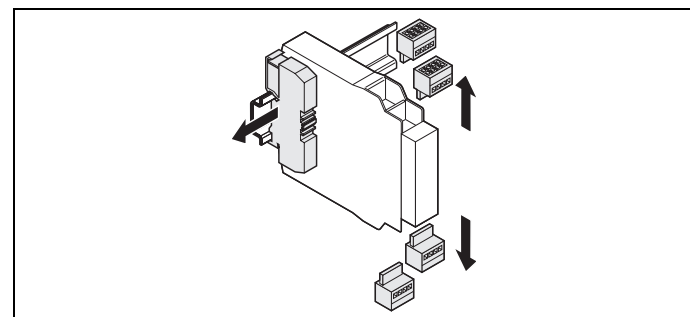

- Remove the removable terminals with wiring and the end clips.

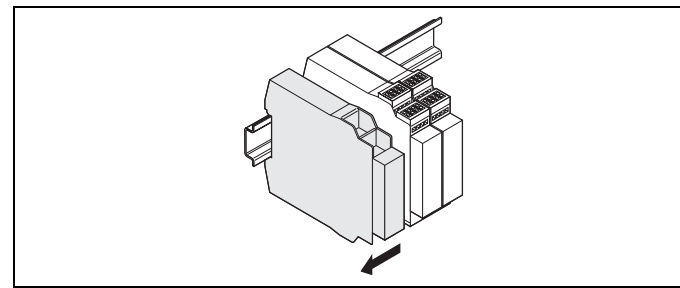

- If there are several modules, slide the modules away from each other individually in the direction of the arrow until the side plug connection is separated.

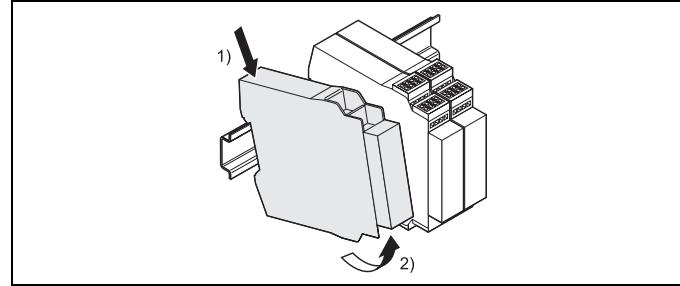

- Press the module downwards at the rear (1)) and remove it from the DIN rail in the direction of the arrow while keeping it pressed down (2)).

## 6 Electrical installation

**ATTENTION** De-energize the entire system! The system could start up unexpectedly while you are connecting the devices.

**Observe the relevant safety standards!** All safety related parts of the installation (cabling, connected sensors and actuators, configuration settings, EDM) must be according to the relevant safety standards (e.g. IEC 62061 or EN/ISO 13849-1).

- The MELSEC-WS safety controller fulfils the EMC requirements in accordance with the basic specification IEC 61000-6-2 for industrial use.
- Electrical installation in accordance with IEC 60204-1
- To ensure full electromagnetic compatibility (EMC), the DIN rail has to be connected to functional earth (FE).
- The voltage supply of the devices must be capable of buffering brief mains voltage failures of 20ms as specified in IEC 60204-1.
- The voltage supply has to fulfil the regulations for extra-low voltages with safe separation (SELV, PELV) in accordance with IEC 60664 and EN 50178 (equipment of electrical power installation with electronic devices).
- You must to connect all the modules of the MELSEC-WS safety controller, the connected protective devices as well as the voltage supply/ies with the same 0VDC (GND).
- All connected pick-ups and downstream controllers as well as wiring and installation have to fulfil the required safety characteristics.
- Depending on the external loads, especially for inductive loads, additional external protective elements, e.g. varistors or RC elements may be necessary in order to protect the safety outputs. Take into account that the response times may increase, depending on the type of protective element.
- If a module is replaced the correct terminal assignment has to be guaranteed, for example by labelling or suitable cable routing.
- For further information that is to be taken into consideration when the MELSEC-WS safety controller is used refer to the "Safety Controller User's Manual" and "Safety Controller Setting and Monitoring Tool Operating Manual".

## 7 Configuration and commissioning

**ATTENTION** Do not commission without a check by qualified safety personnel! Before initial commissioning of a system using a MELSEC-WS safety controller, it must be checked and released by qualified personnel. Document the result of the safety check.

The MELSEC-WS safety controller can be configured by the Setting and Monitoring Tool connected to the RS-232 interface of a CPU module or the port of an Ethernet interface module.

- Note
- The Setting and Monitoring Tool version 1.3.0 or higher is required to configure and commission the MELSEC-WS safety controller.
  - The system configuration of the complete MELSEC-WS safety controller is stored in the memory plug. The system does not have to be reconfigured when a module is replaced.

## 8 Technical data

### 8.1 Technical data WS0-XTIO/WS0-XTDI

Safety Integrity Level	SIL3 (IEC 61508)
Category	Category 4 (EN 13849-1)
Performance Level	PLe (EN/ISO 13849-1)
PFHd (mean probability of a dangerous failure per hour)	See the Safety Controller User's Manual.
T <sub>M</sub> (mission time)	20 years (EN ISO 13849-1)
Protection class	III (IEC 61140)
Enclosure rating	Terminals: IP 20 (IEC 60529) Housing: IP 40 (IEC 60529)
Ambient temperature in operation	-25 ... +55°C
Storage temperature	-25 ... +70°C
Humidity	10% ... 95%, non-condensing
Climatic conditions	55°C, 95% rel. humidity (IEC 61131-2), No corrosive gases
Vibration resistance	10-500Hz/5g (IEC 60068-2-6)
Shock resistance	Continuous shock Single shock
Electromagnetic compatibility	Class A (IEC 61000-6-2, EN 55011)
System connection	Dual level spring clamp terminals
Power input via FLEXBUS+	WS0-XTIO: Max. 2.8W (without currents to X1, X2) WS0-XTDI: Max. 3.3W (without currents to X1 ... X8)
Cross-section of connecting wires	Single-core or finely stranded: 1 × 0.14 ... 2.5mm <sup>2</sup> or 2 × 0.14 ... 0.75mm <sup>2</sup> Finely stranded with wire end ferrules to EN 46228: 1 × 0.25 ... 2.5mm <sup>2</sup> or 2 × 0.25 ... 0.5mm <sup>2</sup>
Data interface	Backplane bus (FLEXBUS+)
Dimensions (WxHxD)	22.5 × 106.5 × 120.8mm
Weight	WS0-XTIO: 180g WS0-XTDI: 150g

#### Input circuit (I1 ... I8)

Input voltage HIGH	13 ... 30VDC
Input voltage LOW	-5 ... +5VDC
Input current HIGH	2.4 ... 3.8mA
Input current LOW	-2.5 ... 2.1mA
Switching current (with mechanical contacts)	14.4mA at 5V 3mA at 24V
Input capacitance	Max. 10nF
Discrepancy times	4ms ... 30s, configurable
Number of inputs	8

#### Test outputs (X1, X2) or (X1 ... X8)

Number of outputs	XTIO: 2 (with 2 test pulse generators) XTDI: 8 (with 2 test pulse generators)
Output type	PNP semiconductor, short-circuit protected, cross circuit monitoring (selectable)
Output voltage High	16 ... 30VDC
Output resistance Low	22Ω +/- 10%, current limited at approx. 10mA (WS0-XTIO only)
Output current	Max. 120mA at a test output
Test pulse rate (test period)	1 ... 25Hz, configurable
Test pulse duration (test gap)	1 ... 100ms, configurable
Load capacity	1μF for test gap ≥ 4ms 0.5μF for test gap 1ms
Cable resistance	< 100Ω

#### Power supply unit (A1, A2) (WS0-XTIO only)

Supply voltage	24VDC (16.8VDC ... 30VDC)
Type of supply voltage	PELV or SELV The current of the power supply unit for the CPU module has to be limited to a maximum of 4A – either by the power supply unit itself or by a fuse.
Power consumption	Max. 96W, determined by the load at the outputs Q1 to Q4
Switch-on time	Max. 18s
Short-circuit protection	4A gG (with tripping characteristic B or C)

### Safety outputs (Q1 ... Q4) (WS0-XTIO only)

Number of outputs	4
Output type	PNP semiconductor, short-circuit protected, cross circuit monitoring (selectable)
Output voltage High	15.6 ... 30VDC
Leakage current Low	Max. 0.1mA Max. 1.6mA
Output current	Max. 2.0A
Total current I <sub>sum</sub>	Max. 4.0A Max. 3.2A Max. 3.2A
Test pulse width	< 650μs
Test pulse rate	Max. 5Hz
Capacitive load	≤ 0.5μF
Cable resistance	Max. 5Ω (e.g. 100m × 1.5mm <sup>2</sup> = 1.2Ω)
Max. permitted coil energy without external protection elements	0.22 J 0.37 J
Response time	Depending on the logic configuration
Data interface	Backplane bus (FLEXBUS+)

Country/Region	Sales office/Tel	Country/Region	Sales office/Tel
U.S.A.	Mitsubishi Electric Automation Inc. 500 Corporate Woods Parkway Vernon Hills, IL 60061, U.S.A. Tel : +1-847-478-2100	China	Mitsubishi Electric Automation (China) Ltd. 4/F Zhi Fu Plaza, No.80 Xin Chang Road, Shanghai 200003, China Tel : +86-21-6120-0808
Brazil	MELCO-TEC Rep. Com.e Assessoria Tecnica Ltda. Rua Correia Dias, 184, Edificio Paraiso Trade Center-8 andar Paraiso, Sao Paulo, SP Brazil Tel : +55-11-5908-8331	Taiwan	Setuyo Enterprise Co., Ltd. 6F No.105 Wu-Kung 3rd.Rd, Wu-Ku Hsiang, Taipei Hsine, Taiwan Tel : +886-2-2299-2499
Germany	Mitsubishi Electric Europe B.V. German Branch Gothaer Strasse 8 D-08880 Ratingen, GERMANY Tel : +49-2102-486-0	Korea	Mitsubishi Electric Automation Korea Co., Ltd. 1480-6, Gayang-dong, Gangseo-gu Seoul 157-200, Korea Tel : +82-2-3660-9552
U.K.	Mitsubishi Electric Europe B.V. UK Branch Travellers Lane, Hatfield, Hertfordshire, AL10 8XB, U.K. Tel : +44-1707-276100	Singapore	Mitsubishi Electric Asia Pte, Ltd. 307 Alexandra Road #05-01/02, Mitsubishi Electric Building, Singapore 159943 Tel : +65-6470-2480
Italy	Mitsubishi Electric Europe B.V. Italian Branch Centro Dir. Colleoni, Pal. Perseo-Ingr.2 Via Paracelso 12, I-20041 Agrate Brianza, Milano, Italy Tel : +39-039-60531	Thailand	Mitsubishi Electric Automation (Thailand) Co., Ltd. Bang-Chan Industrial Estate No.111 Moo 4, Serithai Rd, T.Kannayao, A.Kannayao, Bangkok 10230 Thailand Tel : +66-2-517-1326
Spain	Mitsubishi Electric Europe B.V. Spanish Branch Carretera de Rubi 76-80, E-08190 Sant Cugat del Valles, Barcelona, Spain Tel : +34-93-565-3131	Indonesia	P.T. Autoteknindo Sumber Makmur Muara Karang Selatan, Block A/Utara No.1 Kav. No.11 Kawasan Industri Pergudangan Jakarta - Utara 14440, P.O.Box 5045 Jakarta, 11050 Indonesia Tel : +62-21-6630833
France	Mitsubishi Electric Europe B.V. French Branch 25, Boulevard des Bouvets, F-92741 Nanterre Cedex, France Tel : +33-1-5568-5568	India	Messung Systems Pvt. Ltd. Electronic Sadan NO.III Unit No15, M.I.D.C Bhosari, Pune-411026, India Tel : +91-20-2712-3130
South Africa	Circuit Breaker Industries Ltd. Private Bag 2016, ZA-1600 Isando, South Africa Tel : +27-11-928-2000	Australia	Mitsubishi Electric Australia Pty. Ltd. 348 Victoria Road, Rydalmere, N.S.W 2116, Australia Tel : +61-2-9684-7777

**mitsubishi electric corporation**

HEAD OFFICE: TOKYO BUILDING, 2-3-1 MARUNOUCHI, CHYODOKU, TOKYO 100-8315, JAPAN  
NAGOYA WORKS: 1-14, YADA-2NHASHI 5-CHOME, HISASHIKU, NAGOYA, JAPAN

When exported from Japan, this manual does not require application to the Ministry of Economy, Trade and Industry for service transaction permission.

Specifications subject to change without notice.

**SICK** SICK AG <http://www.sick.com/>