

mitsubishi

QA6ADP QA Conversion Adapter Module

User's Manual

QA6ADP

Thank you for buying the Mitsubishi general-purpose programmable controller MELSEC-Q Series

Prior to use, please read both this manual and detailed manual thoroughly and familiarize yourself with the product.

MELSEC-Q
Mitsubishi Programmable
Controller

MODEL	QA6ADP-U-JE
MODEL CODE	13JY50
IB(NA)-0800402-F(1110)MEE	

● CONDITIONS OF USE FOR THE PRODUCT ●

- (1) Mitsubishi programmable controller ("the PRODUCT") shall be used in conditions;
 - i) where any problem, fault or failure occurring in the PRODUCT, if any, shall not lead to any major or serious accident; and
 - ii) where the backup and fail-safe function are systematically or automatically provided outside of the PRODUCT for the case of any problem, fault or failure occurring in the PRODUCT.

- (2) The PRODUCT has been designed and manufactured for the purpose of being used in general industries.

MITSUBISHI SHALL HAVE NO RESPONSIBILITY OR LIABILITY (INCLUDING, BUT NOT LIMITED TO ANY AND ALL RESPONSIBILITY OR LIABILITY BASED ON CONTRACT, WARRANTY, TORT, PRODUCT LIABILITY) FOR ANY INJURY OR DEATH TO PERSONS OR LOSS OR DAMAGE TO PROPERTY CAUSED BY the PRODUCT THAT ARE OPERATED OR USED IN APPLICATION NOT INTENDED OR EXCLUDED BY INSTRUCTIONS, PRECAUTIONS, OR WARNING CONTAINED IN MITSUBISHI'S USER, INSTRUCTION AND/OR SAFETY MANUALS, TECHNICAL BULLETINS AND GUIDELINES FOR the PRODUCT.

("Prohibited Application")

Prohibited Applications include, but not limited to, the use of the PRODUCT in;

 - Nuclear Power Plants and any other power plants operated by Power companies, and/or any other cases in which the public could be affected if any problem or fault occurs in the PRODUCT.
 - Railway companies or Public service purposes, and/or any other cases in which establishment of a special quality assurance system is required by the Purchaser or End User.
 - Aircraft or Aerospace, Medical applications, Train equipment, transport equipment such as Elevator and Escalator, Incineration and Fuel devices, Vehicles, Manned transportation, Equipment for Recreation and Amusement, and Safety devices, handling of Nuclear or Hazardous Materials or Chemicals, Mining and Drilling, and/or other applications where there is a significant risk of injury to the public or property.

Notwithstanding the above, restrictions Mitsubishi may in its sole discretion, authorize use of the PRODUCT in one or more of the Prohibited Applications, provided that the usage of the PRODUCT is limited only for the specific applications agreed to by Mitsubishi and provided further that no special quality assurance or fail-safe, redundant or other safety features which exceed the general specifications of the PRODUCTS are required. For details, please contact the Mitsubishi representative in your region.

REVISIONS

* The manual number is noted at the lower right of the top cover.

Print Date	*Manual Number	Revision
Aug., 2007	IB(NA)-0800402-A	First printing
Mar., 2008	IB(NA)-0800402-B	Partial correction Section 2.2, 6.1
Mar., 2010	IB(NA)-0800402-C	Partial correction Section 2.2 Addition CONDITIONS OF USE FOR THE PRODUCT
Apr., 2010	IB(NA)-0800402-D	Partial correction Back cover
Mar., 2011	IB(NA)-0800402-E	Partial correction Section6.2
Oct., 2011	IB(NA)-0800402-F	Partial correction Section2.1

This manual confers no industrial property rights or any rights of any other kind, nor does it confer any patent licenses. Mitsubishi electric Corporation cannot be held responsible for any problems involving industrial property rights which may occur as a result of using the contents noted in this manual

CONTENTS

1. OVERVIEW	1
1.1 Overview.....	1
1.2 Included Parts.....	2
2. SYSTEM CONFIGURATION	3
2.1 System Configuration	3
2.2 Configuration Device List.....	5
3. SPECIFICATIONS	8
3.1 General Specifications.....	8
3.2 Performance Specifications.....	9
4. PART NAMES AND SETTING	10
4.1 Part Names.....	10
4.2 Extension Stage Number Setting	11
5. MOUNTING AND INSTALLATION	12
5.1 Mounting/Removal of QA6ADP	12
5.2 Connection/Disconnection of Extension Cable.....	14
6. PRECAUTION FOR USING QA6ADP	17
6.1 Current Consumption of QA6ADP	17
6.2 Voltage Drop of Extension Cable	18
7. COMPATIBLE MODELS LIST	20

GENERIC TERMS AND ABBREVIATIONS

Unless otherwise specified, this manual uses the following generic terms and abbreviations to explain the QA conversion adapter module.

Generic term/Abbreviation	Description
A5□B	Generic term for A52B, A55B, and A58B extension base units on which A series I/O module and special function module can be mounted without power supply.
A6□B	Generic term for A62B, A65B, and A68B extension base units on which A series I/O module and special function module can be mounted.
QA6ADP	Abbreviation for QA6ADP QA conversion adapter module.
QA6ADP+A5□B/A6□B	Abbreviation for A large type extension base unit on which QA6ADP is mounted.

1. OVERVIEW

1.1 Overview

This user's manual describes the specifications, configuration device, part names and setting, and implementation and installation of the QA6ADP QA conversion adapter module.

For contents that are not described in this manual such as safety precautions, EMC and low voltage directives, or error code list, refer to QCPU User's Manual (Hardware Design, Maintenance and Inspection) (SH-080483).

The QA6ADP is the adapter module connecting the A (large type) series extension base unit to the Q series main base unit.

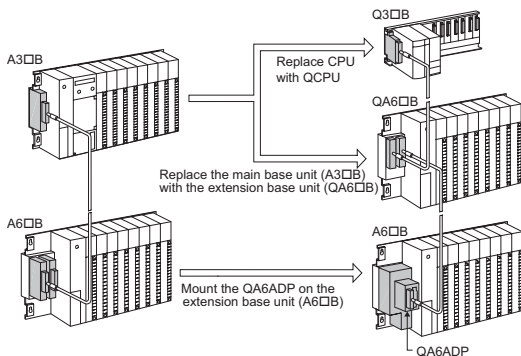

POINT

- The QA6ADP is CE-compliant. To meet the EMC directive, the extension base unit and module to be used in combination with the QA6ADP should be CE-compliant.
- When using a control line or communication cable, keep it away from the main circuit or power line 100mm or more.
Failure to do so may cause malfunction due to noise.

1.2 Included Parts

This section describes parts included with this module.

Product name	Model	Quantity	Remarks
QA6ADP QA conversion adapter module	QA6ADP	1	—
Adapter module mounting bracket	—	1	—
Mounting bracket fixing screw	—	1	—
Board fixing screw	—	1	—
This manual	—	1	—

2. SYSTEM CONFIGURATION

2.1 System Configuration

This section describes the system configuration and restrictions when the QA6ADP is used.

- (1) The QA6ADP+A5□B/A6□B is only applicable for the following CPU modules.
 - High Performance model QCPU
 - Universal model QCPU whose serial number (first five digits) is "13102" or later
- (2) Mount the Q5□B/Q6□B, QA6□B, and QA6ADP+A5□B/A6□B in order from the nearest position of the main base unit.
The QA6ADP cannot be used in combination with the QA1S5□B or QA1S6□B.
- (3) The number of slots of the QA6ADP+A5□B/A6□B is always displayed in 8 slots, regardless of the number of slots of the extension base unit to be used in combination with the QA6ADP. Assign the I/O number of a module, putting each series in block and in order of "Q series→A series" or "A series→Q series". Failure to do so may cause an error (SP.UNITLAY ERR). In addition, do not duplicate the I/O number.
- (4) For the extension stage number setting of the extension base unit, set stage number (the first to seventh stages) to extension stages from the one nearest to the main base unit.
- (5) An extension cable connectable to the QA6ADP is the Q series extension cable only.
- (6) Set the same stage number to both the stage number setting connector of the extension base unit and that of the QA6ADP.
- (7) The QA6ADP+A5□B/A6□B cannot be used as the MELSECNET/H remote I/O station.

(8) The bus connection with GOT is not available for the QA6ADP+A5□B/A6□B.

[Extension stage number setting]

Stage number setting connector

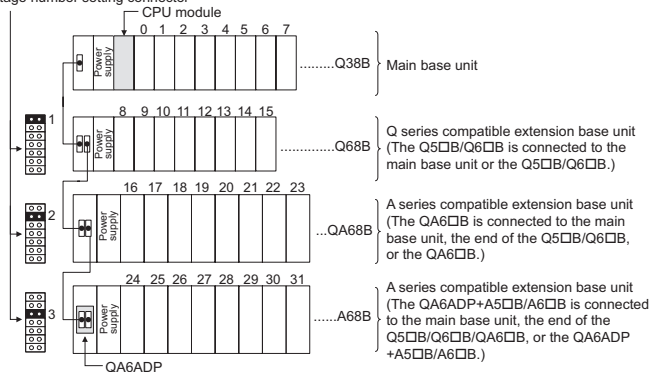

2.2 Configuration Device List

- (1) Extension base unit mountable on the QA6ADP

The following shows extension base units that can be mounted on the QA6ADP.

Product name	Model			Remarks
Extension base unit (Power supply module not mounting type)	A52B, A55B-UL,	A55B, A58B-UL	A58B,	—
Extension base unit (Power supply module mounting type)	A62B, A65B-UL,	A65B, A68B-UL	A68B,	—

- (2) Module mountable on the extension base unit where the QA6ADP is mounted

The following shows modules that can be mounted on the extension base unit where the QA6ADP is mounted.

Product name	Model			Remarks
Power supply module	A61P, A63P,	A61PN, A61PEU,	A62P, A62PEU	—
Power supply module (I/O slot mounting type)	A68P			—
AC input module	AX10, AX20,	AX11, AX21,	AX11EU, AX21EU	*6
AC/DC input module	AX31,	AX31-S1		—
DC input module	AX40, AX42, AX60-S1, AX80, AX81-S1, AX81B,	AX41, AX42-S1, AX70, AX80E, AX81-S2, AX82	AX41-S1, AX50-S1, AX71, AX81, AX81-S3,	—
Contact output module	AY10, AY11A, AY11EEU, AY13EU,	AY10A, AY11E, AY13, AY15EU	AY11, AY11AEU, AY13E,	—
Triac output module	AY22,	AY23		—
Transistor output module	AY40, AY42, AY42-S3, AY51, AY60S, AY71, AY81,	AY40A, AY42-S1, AY42-S4, AY51-S1, AY60E, AY72, AY82EP	AY41, AY42-S2, AY50, AY60, AY70, AY80,	—
Dynamic I/O module	A42XY			—
Combined I/O module	AH42			—

Product name	Model			Remarks
High-speed counter module	AD61,	AD61S1		*1
A/D converter module	A68AD, A616AD	A68AD-S2,	A68ADN,	—
D/A converter module	A62DA, A68DAI-S1,	A62DA-S1, A616DAV,	A68DAV, A616DAI	—
Temperature-digital converter module	A68RD3, A68RD4N, A60MXR, A60MXTN	A68RD3N, A616TD, A60MXRN,	A68RD4, A60MX, A60MXT,	—
Interrupt module	AI61,	AI61-S1		*2
Positioning module	AD70, AD71S1, AD72	AD70D, AD71S2,	AD71, AD71S7,	—
	AD75M1, AD75P1-S3,	AD75M2, AD75P2-S3,	AD75M3, AD75P3-S3	*1
A-A1S module conversion adapter	A1ADP-XY,	A1ADP-SP		*3 *4
MELSECNET/MINI-S3 master module	AJ71PT32-S3, AJ71T32-S3			*1
Intelligent communication module	AD51, AD51E-S3,	AD51E, AD51H,	AD51-S3, AD51H-S3	*2
PC fault detection module	AS91			—
MELSEC-I/OLINK module	AJ51T64			—
B/NET interface module	AJ71B62-S3			—
Blank cover	AG60			—
Dummy module	AG62			—

- *1 The dedicated instructions used in the QnA/A series program cannot be used in the QCPU.
Replace the dedicated instructions with the FROM/TO instructions.
- *2 There is restriction on the number of mountable modules.

Product name	Model		No. of mountable modules
Intelligent communication module	AD51, AD51-S3, AD51H,	AD51E, AD51E-S3, AD51H-S3	6
Interrupt module	AI61,	AI61-S1	1 *5

- *3 Using the A-A1S module conversion adapter enables to use modules equivalent to the AnS module by the module shown in the table. For the mountable modules, refer to A-A1S Module Conversion Adapter User's Manual (IB-0800352).
- *4 Only the multidrop link function can be used with the A1SJ71UC24-R4+A1ADP.
- *5 The interrupt module can use only one out of the QI60 (when mounted on the Q3□B, Q5□B or Q6□B), AI61, and AI61-S1.
- *6 The normal operation of A series AC input module can be guaranteed only when the base unit on which the A series power supply module is mounted exists in the system.
Make sure that the following condition is satisfied when A series AC input module is used.
- A series AC input module is mounted on the QA6□B or QA6ADP+A6□B.
 - A series AC input module is mounted on the QA6ADP+A5□B. However, A series compatible extension base unit, QA6□B or QA6ADP+A6□B, exists in the system.

3. SPECIFICATIONS

3.1 General Specifications

This section describes general specifications of the QA6ADP.

Item	Specifications					
Operating ambient temperature	0 to 55 °C					
Storage ambient temperature	-20 to 75 °C					
Operating ambient humidity	10 to 90 % RH, No-condensing					
Storage ambient humidity	10 to 90 % RH, No-condensing					
Vibration resistance	Conforming to JIS B 3502, IEC 61131-2	Under intermittent vibration	Frequency	Acceleration	Amplitude	Sweep count 10 times each in X, Y, Z directions
			10 to 57 Hz	—	0.075 mm	
		57 to 150 Hz	9.8 m/s ²	—		
		Under continuous vibration	10 to 57 Hz	—	00.35 mm (0.001 in.)	
			57 to 150 Hz	4.9 m/s ²	—	
Shock resistance	Conforming to JIS B 3502, IEC 61131-2 (147 m/s ² , 3 times in each of 3 directions XYZ)					
Operation ambience	No corrosive gasses					
Operating elevation *3	0 to 2000 m					
Installation location	Control panel					
Overvoltage category *1	II max.					
Pollution degree *2	2 max.					
Equipment category	Class I					

- *1 This indicates the section of the power supply to which the equipment is assumed to be connected between the public electrical power distribution network and the machinery within premises.
Category II applies to equipment for which electrical power is supplied from fixed facilities.
The surge voltage withstand level for up to the rated voltage of 300 V is 2500 V.
- *2 This index indicates the degree to which conductive material is generated in terms of the environment in which the equipment is used.
Pollution level 2 is when only non-conductive pollution occurs. A temporary conductivity caused by condensing must be expected occasionally.

- *3 Do not use or store the programmable controller in the environment when the pressure is higher than the atmospheric pressure at sea level. Otherwise, malfunction may result.
To use the programmable controller in high-pressure environment, please contact your local Mitsubishi Representative.

3.2 Performance Specifications

This section describes performance specifications of the QA6ADP.

Item	Specifications
5VDC internal current consumption	110 mA
External dimensions *1	130 mm (5.11 inch) (H) × 73.5 mm (2.89 inch) (W) × 74 (2.91 inch) mm (D)
Weight	0.2 kg
Adapter mounting screw (M3) torque	0.36 to 0.48 N•m
Board fixing screw torque	0.61 to 0.82 N•m

- *1 The external dimensions show values in a status where the QA6ADP is mounted on the extension base unit.

4. PART NAMES AND SETTING

4.1 Part Names

This section describes part names of the QA6ADP

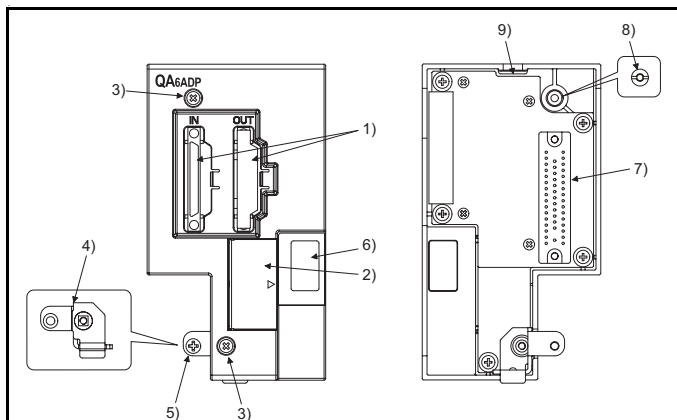

No.	Name	Application
1)	Extension cable connector	Connector for sending/receiving signals to the main base unit or the other extension base unit and connecting an extension cable.
2)	Stage number setting connector	Connector for setting the number of extension stages.
3)	Adapter module mounting screw (M3 screw)	Screw for mounting this adapter module on the extension base unit.
4)	Adapter module mounting bracket	Bracket for mounting this adapter module on the extension base unit. Utilize screws used in the extension base unit. (Included parts)
5)	Mounting bracket fixing screw	Screw for mounting an adapter module mounting bracket on the extension base unit. (Included parts)
6)	Base side stage number setting connector window	Window is transparent so that a stage number setting connector of the extension base unit side can be seen.
7)	Extension base unit mounting connector	Connector to be connected to the A extension cable I/O connector of the extension base unit.
8)	Board fixing screw	Screw for mounting this adapter module on the extension base unit. (Included parts)
9)	Mounting guide	Guide for positioning an extension base unit mounting connector by inserting this into a cover fixing square hole of the extension base unit at the time of mounting.

4.2 Extension Stage Number Setting

Set the number of extension stages to both the QA6ADP and the extension base unit.

The same stage number should be set to both the stage number setting connector of the extension base unit and that of the QA6ADP.

POINT

Set any number of 1 to 7 which matches to the number of extension stages for the stage number setting connector setting. If the stage number setting of the QA6ADP and that of the extension base unit is different, the two or more settings are made to one stage, the same stage number is duplicated, or no setting is made to the number of stages, incorrect input or incorrect output will occur.

(1) Extension stage number setting of the QA6ADP

The following describes how to set the number of extension stages of the QA6ADP.

Stage number setting connector setting	Extension stage number setting						
	1 st stage	2 nd stage	3 rd stage	4 th stage	5 th stage	6 th stage	7 th stage
	P1IN1	P1IN1	P1IN1	P1IN1	P1IN1	P1IN1	P1IN1

(2) Extension stage number setting of the extension base unit

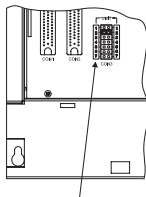
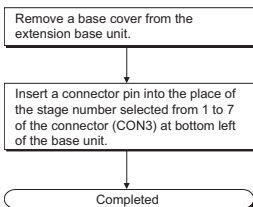

Stage number setting connector

Stage number setting connector setting	Extension stage number setting						
	1 st stage	2 nd stage	3 rd stage	4 th stage	5 th stage	6 th stage	7 th stage
	CON3	CON3	CON3	CON3	CON3	CON3	CON3

5. MOUNTING AND INSTALLATION

5.1 Mounting/Removal of QA6ADP

(1) Mounting of the QA6ADP

The following shows procedures for mounting the QA6ADP on the extension base unit.

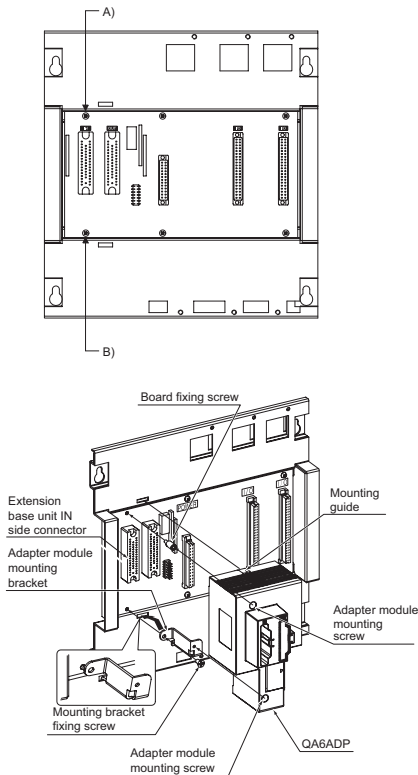
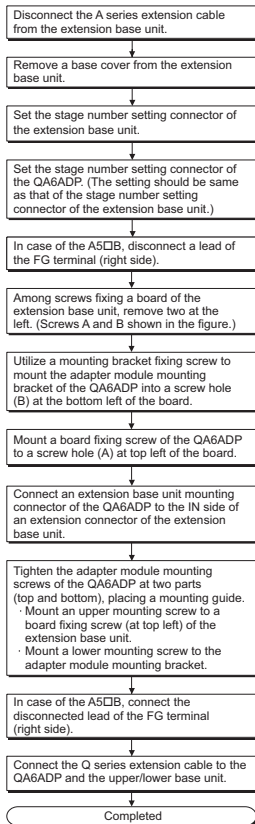

(2) Removal of the QA6ADP

The following shows procedures for removing the QA6ADP from the extension base unit.

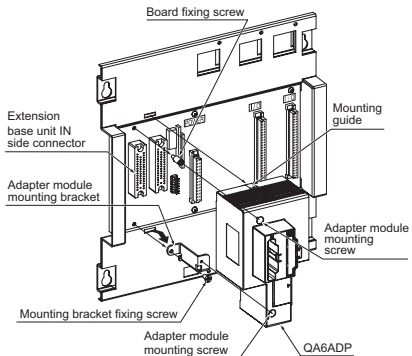
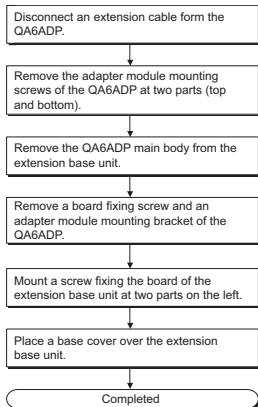

5.2 Connection/Disconnection of Extension Cable

- (1) Precautions for handling an extension cable
 - Do not step on an extension cable.
 - When laying an extension cable, the minimum bend radius of the cable should be 55 mm (2.17 inch) or more. If it is less than 55 mm (2.17 inch), malfunction may occur due to characteristic deterioration, wire break etc.
 - When connecting or disconnecting an extension cable, do not hold ferrite cores mounted at both ends of the cable. In case of connecting/disconnecting a cable, hold the connector part of the cable.

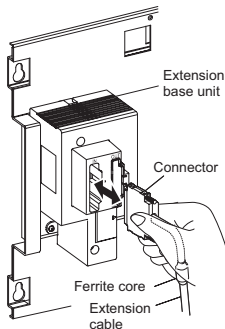

Holding a ferrite core may cause cable break inside the connector. Also, if the ferrite core is shifted, the characteristic will change. When handling the cable, take care not to change position of the ferrite core.

- (2) Connection of extension cable

The following shows extension cables connectable to the QA6ADP.

Model	Remarks
QC05B	0.45m cable
QC06B	0.6m cable
QC12B	1.2m cable
QC30B	3m cable
QC50B	5m cable
QC100B	10m cable

POINT

When connecting the base unit of the previous stage and the QA6ADP with an extension cable, be sure to connect the OUT side connector of the base unit of the previous stage and the IN side connector of the QA6ADP.

If an extension cable is connected in the wrong way (IN→IN, OUT→OUT or IN→OUT), the system will not operate normally.

- To connect an extension cable to the QA6ADP, remove a sticker on the IN side connector.

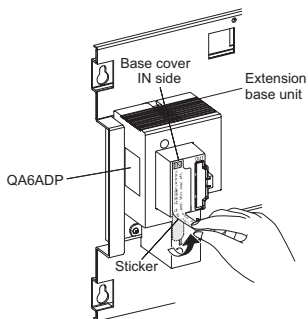

- To connect an extension cable to the OUT side connector of the QA6ADP, remove the portion (lid) under the characters "OUT" by tools such as a flathead screwdriver (5.5×75, 6×100).

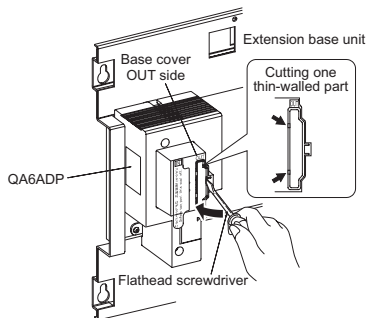

- Hold the connector part of an extension cable when connecting the extension cable to the QA6ADP.

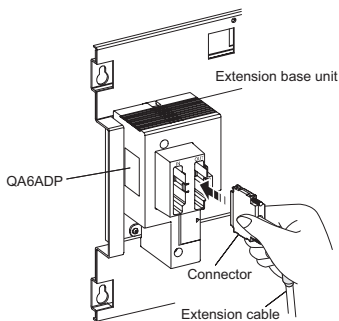

- Make sure to tighten fixing screws of the extension cable connector after connecting the extension cable.
(Tightening torque: 0.20 N•m)

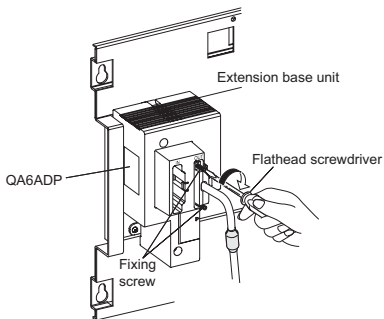

- (3) Disconnection of extension cable
When disconnecting an extension cable, hold and pull the connector part of the extension cable after making sure that fixing screws have been completely removed.

6. PRECAUTION FOR USING QA6ADP

6.1 Current Consumption of QA6ADP

Since 5VDC is supplied to the QA6ADP from the power supply module of the main base unit, take the current consumption of the QA6ADP into consideration when selecting the power supply module for the main base unit.

Current consumption of CPU and I/O of main base unit + Current consumption of I/O of Q5□B + Current consumption of I/O of A5□B + Current consumption of QA6ADP × n

n: Quantity of QA6ADP in system**

*1 The quantity of the QA6ADP includes the QA6ADP when the A6□B is used.

The following shows the concept of the current consumption of the power supply module mounted on the main base unit.

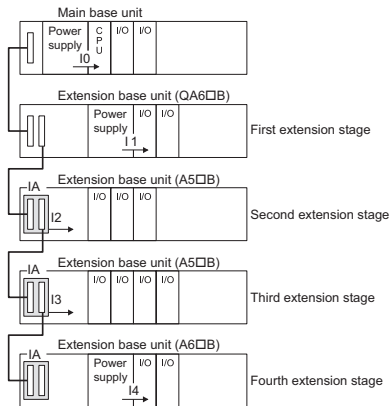

Symbol	Description
I	Rated current of power supply module on the main base unit
I0	Current consumption of CPU and I/O modules mounted on the main base unit
I1 to I4	Current consumption of I/O mounted on the extension base unit in first to fourth stages
IA	Current consumption of the QA6ADP

In case of the above system, use the QA6ADP when the current consumption of the power supply module mounted on the main base unit meets the following formula.

[Calculating formula]

$$I > I_0 + I_2 + I_3 + I_A \times 3$$

6.2 Voltage Drop of Extension Cable

Since 5VDC is supplied to the QA6ADP from the power supply module mounted on the main base unit, the voltage drop will be caused in the extension cable.

If the specified voltage (4.75VDC or more) is not supplied to the IN side connector of the QA6ADP+A5□B/A6□B, wrong input/output may occur. When using the QA6ADP, check that the IN side connector of the QA6ADP+A5□B/A6□B has 4.75VDC or more.

The following shows an example regarding how to calculate the voltage drop.

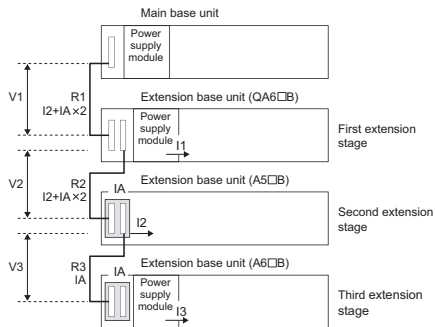

Model	Conductor resistance value
QC05B	0.044Ω
QC06B	0.051Ω
QC12B	0.082Ω
QC30B	0.172Ω
QC50B	0.273Ω
QC100B	0.530Ω

Symbol	Description
V	Sum of voltage drop
V1	Voltage drop due to an extension cable between the main base unit and the QA6□B
Vn	Voltage drop due to an extension cable between the extension base unit (n-1th extension stage) and the extension base unit (nth extension stage)
R1	Resistance value of a cable between the main base unit and the extension base unit QA6□B
Rn	Resistance value of an extension cable between the extension base unit (n-1th extension stage) and the extension base unit (nth extension stage)
I1 to I3	Current consumption (5VDC) at the first to the third extension base units*1
IA	Current consumption of the QA6ADP

*1 Current consumption at each extension base unit is as follows:

First extension base unit: None

Second extension base unit: IA+I2

Third extension base unit: IA

Since the first extension base unit and the third extension base unit are supplied from the power supply module on each extension base unit, the values are not included above.

Since the current consumptions I1 to I3 vary depending on modules to be mounted, refer to the manual for the module to be mounted.

[Calculating formula]

$$V = V1 + V2 + V3 = R1 \times (I2 + IA \times 2) + R2 \times (I2 + IA \times 2) + R3 \times IA$$

The minimum value of the 5VDC output voltage of the power supply module mounted on the main base unit is set to 4.90VDC. Therefore, the voltage of the IN side connector of the QA6ADP+A5□B/A6□B in the final stage is 4.75VDC or more only when the sum (V) of voltage drop is 0.15V or less.

7. COMPATIBLE MODELS LIST

This chapter describes external dimensions of the QA6ADP.

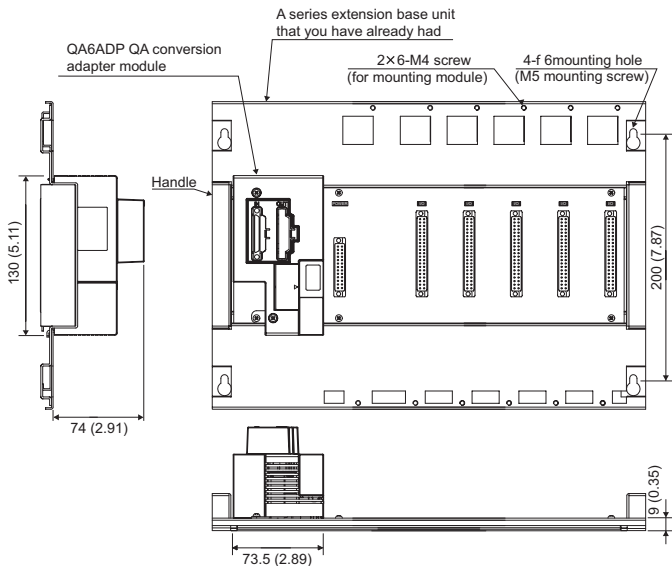

Power supply module, Extension cable

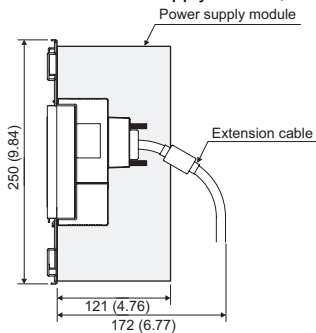

Unit: mm (inch)

WARRANTY

Mitsubishi will not be held liable for damage caused by factors found not to be the cause of Mitsubishi; machine damage or lost profits caused by faults in the Mitsubishi products; damage, secondary damage, accident compensation caused by special factors unpredictable by Mitsubishi; damages to products other than Mitsubishi products; and to other duties.

Country/Region	Sales office/Tel	Country/Region	Sales office/Tel
U.S.A	Mitsubishi Electric Automation Inc. 500 Corporate Woods Parkway Vernon Hills, IL 60061, U.S.A. Tel : +1-847-478-2100	China	Mitsubishi Electric Automation (China) Ltd. 4/F Zhi Fu Plazz, No.80 Xin Chang Road, Shanghai 200003, China Tel : +86-21-6120-0808
Brazil	MELCO-TEC Rep. Com.e Assessoria Tecnica Ltda. Rua Correia Dias, 184, Edificio Paraiso Trade Center-8 andar Paraiso, Sao Paulo, SP Brazil Tel : +55-11-5908-8331	Taiwan	Setsuyo Enterprise Co., Ltd. 6F No.105 Wu-Kung 3rd.Rd, Wu-Ku Hsiang, Taipei Hsine, Taiwan Tel : +886-2-2299-2499
Germany	Mitsubishi Electric Europe B.V. German Branch Gothaer Strasse 8 D-40880 Ratingen, GERMANY Tel : +49-2102-486-0	Korea	Mitsubishi Electric Automation Korea Co., Ltd. 1480-6, Gayang-dong, Gangseo-ku Seoul 157-200, Korea Tel : +82-2-3660-9552
U.K	Mitsubishi Electric Europe B.V. UK Branch Travellers Lane, Hatfield, Hertfordshire., AL10 8XB, U.K. Tel : +44-1707-276100	Singapore	Mitsubishi Electric Asia Pte. Ltd. 307 Alexandra Road #05-01/02, Mitsubishi Electric Building, Singapore 159943 Tel : +65-6470-2480
Italy	Mitsubishi Electric Europe B.V. Italian Branch Centro Dir. Colleoni, Pal. Perseo-Ingr.2 Via Paracelso 12, I-20041 Agrate Brianza., Milano, Italy Tel : +39-039-60531	Thailand	Mitsubishi Electric Automation (Thailand) Co., Ltd. Bang-Chan Industrial Estate No.111 Moo 4, Serithai Rd, T.Kannayao, A.Kannayao, Bangkok 10230 Thailand Tel : +66-2-517-1326
Spain	Mitsubishi Electric Europe B.V. Spanish Branch Carretera de Rubi 76-80, E-08190 Sant Cugat del Valles, Barcelona, Spain Tel : +34-93-565-3131	Indonesia	P.T. Autoteknindo Sumber Makmur Muara Karang Selatan, Block A/Utara No.1 Kav. No.11 Kawasan Industri Pergudangan Jakarta - Utara 14440, P.O.Box 5045 Jakarta, 11050 Indonesia Tel : +62-21-6630833
France	Mitsubishi Electric Europe B.V. French Branch 25, Boulevard des Bouvets, F-92741 Nanterre Cedex, France Tel : +33-1-5568-5568	India	Messung Systems Pvt, Ltd. Electronic Sadan NO:III Unit No15, M.I.D.C Bhosari, Pune-411026, India Tel : +91-20-2712-3130
South Africa	Circuit Breaker Industries Ltd. Private Bag 2016, ZA-1600 Isando, South Africa Tel : +27-11-928-2000	Australia	Mitsubishi Electric Australia Pty. Ltd. 348 Victoria Road, Rydalmere, N.S.W 2116, Australia Tel : +61-2-9684-7777

MITSUBISHI ELECTRIC CORPORATION

HEAD OFFICE : TOKYO BUILDING, 2-7-3 MARUNOUCHI, CHIYODA-KU, TOKYO 100-8310, JAPAN
NAGOYA WORKS : 1-14, YADA-MINAMI 5-CHOME, HIGASHI-KU, NAGOYA, JAPAN

When exported from Japan, this manual does not require application to the Ministry of Economy, Trade and Industry for service transaction permission.