

# MITSUBISHI

## Insulation Displacement Connector for MELSEC-Q Series 32-Point I/O Module

### User's Manual

## Q6TA32

Thank you for purchasing the Mitsubishi programmable controller MELSEC-Q series.

Prior to use, please read this manual thoroughly and familiarize yourself with the product

**MELSEC-Q**  
Mitsubishi Programmable  
Controller

MODEL	Q6TA32-U-JE
MODEL CODE	13JT92
IB(NA)-0800228-D(1110)MEE	

## ● SAFETY PRECAUTIONS ●

(Read these precautions before using this product.)

Before using this product, please read this manual and the relevant manuals carefully and pay full attention to safety to handle the product correctly.

In this manual, the safety precautions are classified into two levels:  
"⚠ WARNING" and "⚠ CAUTION".



Indicates that incorrect handling may cause hazardous conditions, resulting in death or severe injury.



Indicates that incorrect handling may cause hazardous conditions, resulting in minor or moderate injury or property damage.

Under some circumstances, failure to observe the precautions given under "⚠ CAUTION" may lead to serious consequences.

Observe the precautions of both levels because they are important for personal and system safety.

Make sure that the end users read this manual and then keep the manual in a safe place for future reference.

### [DESIGN PRECAUTIONS]

#### ⚠ CAUTION

- Do not bunch the control wires or communication cables with the main circuit or power line, or install them close to each other.  
They should be installed 100 mm (3.94 inch) or more from each other.  
Otherwise, noise may occur and result in malfunction.

## [INSTALLATION PRECAUTIONS]

### CAUTION

- Use the programmable controller in an environment that meets the general specifications given in the user's manual for the CPU module used. Failure to do so may result in electric shock, fire, malfunction, or damage to or deterioration of the product.
- When installing this product on an I/O module, securely install it using 2 fixing screws (M2.6). Incorrect installation may cause this product to fall out, the I/O module to malfunction or similar problems to occur.
- Shut off the external power supply for the system in all phases before mounting or removing this product. Otherwise, the I/O module may go down or malfunction.

## [WIRING PRECAUTIONS]

### WARNING

- Shut off the external power supply for the system in all phases before wiring. Otherwise, an electric shock may occur or this product may be damaged.

### CAUTION

- When wiring this product, be sure that the terminal layout is correct and the I/O module's rated voltage is used. Connecting a power supply out of the rating or miswiring could result in fire or damage.
- Make sure that the applicable wires are crimped onto the terminal conductors before using this product.
- Be careful not to let foreign matters such as sawdust or wire chips get inside this product or the I/O module. These may cause fire, damage, or malfunction.

## [STARTING AND MAINTENANCE PRECAUTIONS]

### WARNING

- Do not insert or pull out the wires when power is on.  
It may cause a malfunction or electric shock.
- Always clean or retighten fixing screws after switching power off externally in all phases.  
Otherwise, the I/O module may malfunction.

### CAUTION

- Do not disassemble or rebuild this product.  
It may cause accidents, malfunction, injury, or fire.
- Shut off the external power supply for the system in all phases before mounting or removing this product.  
Otherwise, the I/O module may go down or malfunction.
- Before handling the connector, touch a grounded metal object to discharge the static electricity from the human body.  
Failure to do so may cause the module to fail or malfunction.

## [DISPOSAL PRECAUTIONS]

### CAUTION

- When disposing this product, handle it as industrial waste.

## ● **CONDITIONS OF USE FOR THE PRODUCT** ●

- (1) Mitsubishi programmable controller ("the PRODUCT") shall be used in conditions;
  - i) where any problem, fault or failure occurring in the PRODUCT, if any, shall not lead to any major or serious accident; and
  - ii) where the backup and fail-safe function are systematically or automatically provided outside of the PRODUCT for the case of any problem, fault or failure occurring in the PRODUCT.
  
- (2) The PRODUCT has been designed and manufactured for the purpose of being used in general industries.

MITSUBISHI SHALL HAVE NO RESPONSIBILITY OR LIABILITY (INCLUDING, BUT NOT LIMITED TO ANY AND ALL RESPONSIBILITY OR LIABILITY BASED ON CONTRACT, WARRANTY, TORT, PRODUCT LIABILITY) FOR ANY INJURY OR DEATH TO PERSONS OR LOSS OR DAMAGE TO PROPERTY CAUSED BY the PRODUCT THAT ARE OPERATED OR USED IN APPLICATION NOT INTENDED OR EXCLUDED BY INSTRUCTIONS, PRECAUTIONS, OR WARNING CONTAINED IN MITSUBISHI'S USER, INSTRUCTION AND/OR SAFETY MANUALS, TECHNICAL BULLETINS AND GUIDELINES FOR the PRODUCT.

("Prohibited Application")

Prohibited Applications include, but not limited to, the use of the PRODUCT in;

  - Nuclear Power Plants and any other power plants operated by Power companies, and/or any other cases in which the public could be affected if any problem or fault occurs in the PRODUCT.
  - Railway companies or Public service purposes, and/or any other cases in which establishment of a special quality assurance system is required by the Purchaser or End User.
  - Aircraft or Aerospace, Medical applications, Train equipment, transport equipment such as Elevator and Escalator, Incineration and Fuel devices, Vehicles, Manned transportation, Equipment for Recreation and Amusement, and Safety devices, handling of Nuclear or Hazardous Materials or Chemicals, Mining and Drilling, and/or other applications where there is a significant risk of injury to the public or property.

Notwithstanding the above, restrictions Mitsubishi may in its sole discretion, authorize use of the PRODUCT in one or more of the Prohibited Applications, provided that the usage of the PRODUCT is limited only for the specific applications agreed to by Mitsubishi and provided further that no special quality assurance or fail-safe, redundant or other safety features which exceed the general specifications of the PRODUCTS are required. For details, please contact the Mitsubishi representative in your region.

## REVISIONS

\* The manual number is given on the bottom right of the top cover.

Print Date	*Manual Number	Revision
Feb., 2002	IB(NA)-0800228-A	First edition
Jan., 2003	IB(NA)-0800228-B	Manual title change Pressure-Displacement Terminal Block Adaptor for MELSEC-Q Series 32-Point I/O Module
Sep., 2009	IB(NA)-0800228-C	SAFETY PRECAUTIONS, Chapter 1, 2, 3,4, Section 5.2
Oct., 2011	IB(NA)-0800228-D	SAFETY PRECAUTIONS (Chinese)

This manual confers no industrial property rights or any rights of any other kind, nor does it confer any patent licenses. Mitsubishi electric Corporation cannot be held responsible for any problems involving industrial property rights which may occur as a result of using the contents noted in this manual.

## CONTENTS

1. OVERVIEW.....	1
2. PERFORMANCE SPECIFICATIONS .....	2
3. NAMES OF PARTS .....	3
4. HANDLING INSTRUCTIONS .....	5
5. WIRING .....	6
5.1 Wiring Instructions .....	6
5.2 External Wiring .....	7
5.3 Wiring Procedure .....	8
6. EXTERNAL DIMENTIONS .....	10

## MANUALS

The following manual is related to this product.  
Please order it if necessary.

Related manual

Manual Name	Manual Number (Model Code)
I/O Module Type Building Block User's Manual	SH-080042 (13JL99)



---

## 1. OVERVIEW

---

This manual describes the specifications, handling, part names and others of the Q6TA32 insulation displacement connector for MELSEC-Q series 32-point I/O module (hereinafter referred to as the Q6TA32). The Q6TA32 is to be connected to the connector of the Q Series 40-pin connector type 32-point I/O module in order to convert the module connector into an insulation displacement connector.

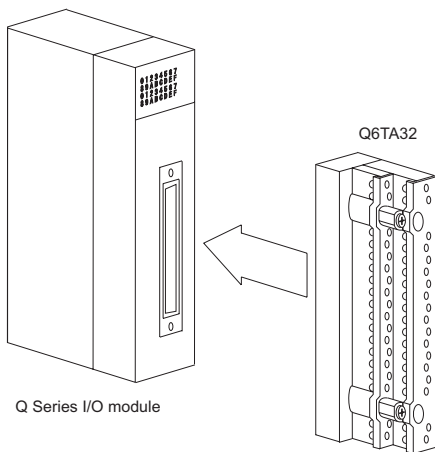

### Packing list

Type	Product
Q6TA32	32-point insulation displacement connector
Q6TA32-TOL	Wiring tool (sold separately)

## 2. PERFORMANCE SPECIFICATIONS

The following table lists the performance specifications of the Q6TA32.

Item		Specifications
Applicable model		QX41, QX41-S1, QX71, QY41P, QY71
Applicable wire *2		Polyvinyl chloride wire (twisted wire) Nominal 0.5 mm <sup>2</sup> (20AWG) max. insulation diameter: φ1.9 mm (0.07 inch)
Number of connectable wire		1
Tensile strength *1 of wire	To the left	35N
	Forward	22N
	Upward or downward	60N
Number of wire insertion/ disconnection times		30
Max. allowable voltage		250VAC
Max. allowable current		3ADC
Contact resistance		100m (327.8 feet) Ω or less
Weight		0.08 kg (0.18 lb.)

\*1 Direction of tensile strength of wire

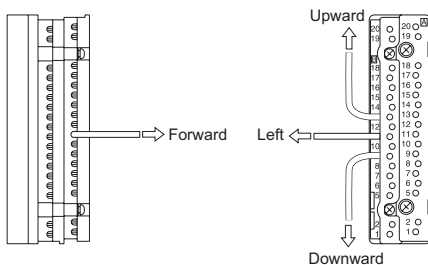

\*2 Use the "UL STYLE 1007" or "CSA TYPE TR-64" type cable.

### 3. NAMES OF PARTS

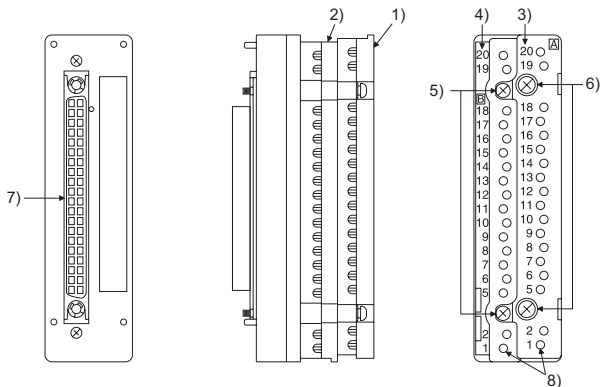

No.	Name	Description
1)	Line A cover	Cover for the insulation displacement connector line A
2)	Line B cover	Cover for the insulation displacement connector line B
3)	Terminal number (Line A)	Indicate the I/O module pin number A1 to A20 corresponding to the insulation displacement terminals.
4)	Terminal number (Line B)	Indicate the I/O module pin number B1 to B20 corresponding to the insulation displacement terminals.
5)	Cover fixing screw	Screw for fixing the cover (M2.6 screw)
6)	Insulation displacement connector fixing screw	Screw for fixing the Q6TA32 to the I/O module connector (M2.6 screw)
7)	Connector	Connector for connection to the I/O module.
8)	Tester lead-in port	Hole through which a tester lead is drawn for continuity check.



---

---

## 4. HANDLING INSTRUCTIONS

---

---

- (1) Do not use solid wires with this connector.
- (2) Do not drop the connector case and wiring tool or give them high impact since they are made of resin.
- (3) Do not disassemble the connector case.  
It may cause a failure.
- (4) Tighten the fixing screws and cover fixing screws within the following ranges.

Screw	Tightening Torque Range
Insulation displacement connector fixing screw (M2.6 screw)	0.21 to 0.28 N · m
Cover fixing screw (M2.6 screw)	0.21 to 0.28 N · m

- (5) When the Q6TA32 is installed to the I/O module, it is 9 mm (0.35 inch) out of the I/O module bottom. (Refer to "6. OUTLINE DRAWING".)  
Pay attention to the installation position.
- (6) The Q6TA32 cannot be used with any model that is not mentioned as the applicable model in the performance specifications.

---

---

## 5. WIRING

---

---

### 5.1 Wiring Instructions

- (1) Do not strip the insulation of the connectable wire before wiring.
- (2) The number of connectable wire per terminal is 1.
- (3) Wire the far side line B terminals first.
- (4) To prevent the wires from pushing the adjacent modules, connect them after pulling them toward you within the wire's tensile strength range given in the performance specifications.

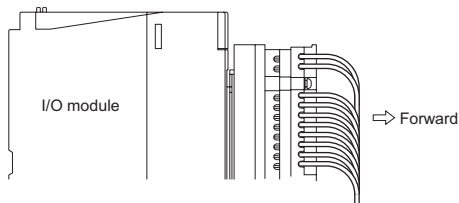

- (5) During and after wiring, do not apply loads larger than the wire's tensile strength given in the performance specifications to the wires.
- (6) When reusing the wire that has been connected to this connector once, cut off its insulation displacement end face in advance.

## 5.2 External Wiring

The following table indicates the terminal number and the corresponding signal name.

(When the head I/O number of the I/O module is set to 0)

Input Module (QX41, QX41-S1, QX71)				Output Module (QY41P, QY71 <sup>*1</sup> )			
Terminal number	Signal name	Terminal number	Signal name	Terminal number	Signal name	Terminal number	Signal name
B20	X00	A20	X10	B20	Y00	A20	Y10
B19	X01	A19	X11	B19	Y01	A19	Y11
B18	X02	A18	X12	B18	Y02	A18	Y12
B17	X03	A17	X13	B17	Y03	A17	Y13
B16	X04	A16	X14	B16	Y04	A16	Y14
B15	X05	A15	X15	B15	Y05	A15	Y15
B14	X06	A14	X16	B14	Y06	A14	Y16
B13	X07	A13	X17	B13	Y07	A13	Y17
B12	X08	A12	X18	B12	Y08	A12	Y18
B11	X09	A11	X19	B11	Y09	A11	Y19
B10	X0A	A10	X1A	B10	Y0A	A10	Y1A
B9	X0B	A9	X1B	B9	Y0B	A9	Y1B
B8	X0C	A8	X1C	B8	Y0C	A8	Y1C
B7	X0D	A7	X1D	B7	Y0D	A7	Y1D
B6	X0E	A6	X1E	B6	Y0E	A6	Y1E
B5	X0F	A5	X1F	B5	Y0F	A5	Y1F
B4 <sup>*2</sup>	-	A4 <sup>*2</sup>	-	B4 <sup>*2</sup>	-	A4 <sup>*2</sup>	-
B3 <sup>*2</sup>	-	A3 <sup>*2</sup>	-	B3 <sup>*2</sup>	-	A3 <sup>*2</sup>	-
B2	COM	A2	Empty	B2	12/24VDC <sup>*1</sup>	A2	COM
B1	COM	A1	Empty	B1	12/24VDC <sup>*1</sup>	A1	COM

\*1 B1 and B2 of the QY71 are used at 5/12VDC.

\*2 The Q6TA32 does not have the terminal number A3, A4, B3 and B4.

## 5.3 Wiring Procedure

### (1) Wire connection

- 1) Install the Q6TA32 to the I/O module with the insulation displacement connector fixing screws, loosen the cover fixing screws, and remove the covers.

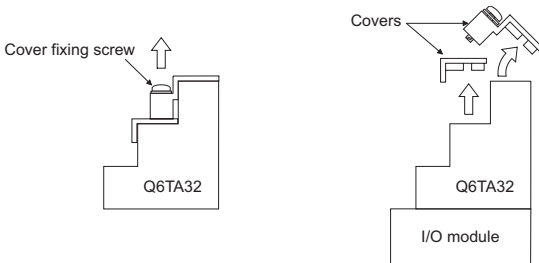

- 2) Insert the wire along the guide inside the Q6TA32 without a gap, push it in gently with your finger to temporarily hold it, and push it far enough with the wiring tool.

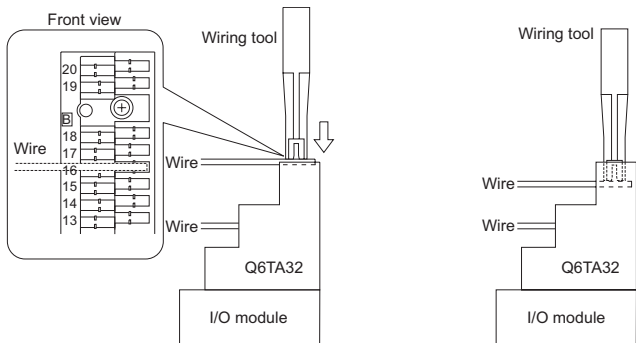

When wiring Line A (right side), check the numeral of Line B (left side) to confirm the terminal number to be wired.

- 3) Install the covers to the Q6TA32 and tighten the cover fixing screws.

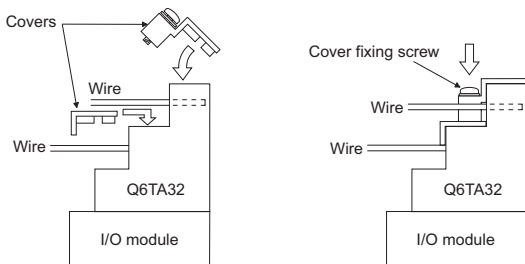

- 4) Using a tester, make a continuity check.

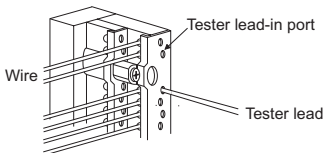

- (2) Disconnecting the wire

Loosen the cover fixing screws, remove the covers, and pull the wire toward you.

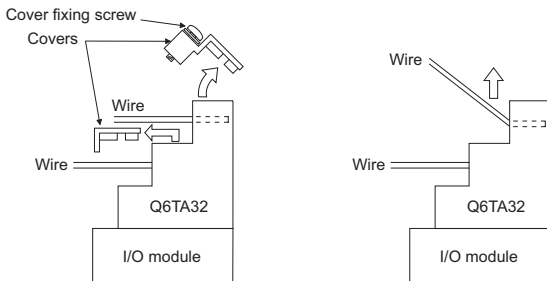

## 6. EXTERNAL DIMENSIONS

(1) Q6TA32 (When mounted on an I/O module)

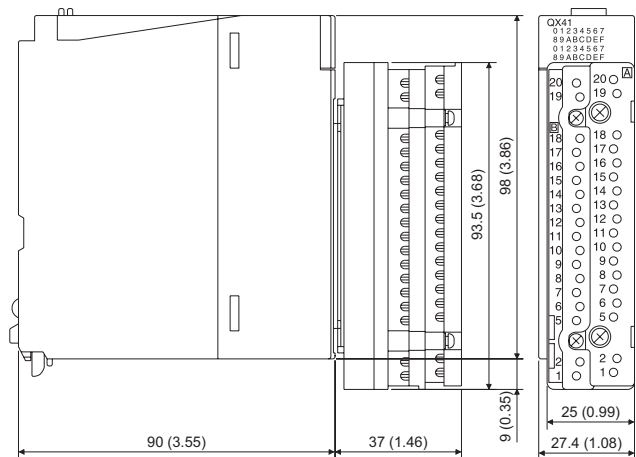

(2) Q6TA32-TOL

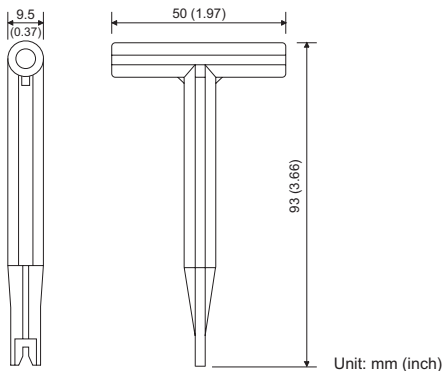



## WARRANTY

Mitsubishi will not be held liable for damage caused by factors found not to be the cause of Mitsubishi; machine damage or lost profits caused by faults in the Mitsubishi products; damage, secondary damage, accident compensation caused by special factors unpredictable by Mitsubishi; damages to products other than Mitsubishi products; and to other duties.

Country/Region	Sales office/Tel	Country/Region	Sales office/Tel
U.S.A	Mitsubishi Electric Automation Inc. 500 Corporate Woods Parkway Vernon Hills, IL 60061, U.S.A. Tel : +1-847-478-2100	China	Mitsubishi Electric Automation (China) Ltd. 4/F Zhi Fu Plaza, No.80 Xin Chang Road, Shanghai 200003, China Tel : +86-21-6120-0808
Brazil	MELCO-TEC Rep. Com.e Assessoria Tecnica Ltda. Rua Correia Dias, 184, Edifício Paraiso Trade Center-8 andar Paraiso, Sao Paulo, SP Brazil Tel : +55-11-5908-8331	Taiwan	Setsuyo Enterprise Co., Ltd. 6F No.105 Wu-Kung 3rd.Rd, Wu-Ku Hsiang, Taipei Hsine, Taiwan Tel : +886-2-2299-2499
Germany	Mitsubishi Electric Europe B.V. German Branch Gothaer Strasse 8 D-40880 Ratingen, GERMANY Tel : +49-2102-486-0	Korea	Mitsubishi Electric Automation Korea Co., Ltd. 1480-6, Gayang-dong, Gangseo-ku Seoul 157-200, Korea Tel : +82-2-3660-9552
U.K	Mitsubishi Electric Europe B.V. UK Branch Travellers Lane, Hatfield, Hertfordshire., AL10 8XB, U.K. Tel : +44-1707-276100	Singapore	Mitsubishi Electric Asia Pte, Ltd. 307 Alexandra Road #05-01/02, Mitsubishi Electric Building, Singapore 159943 Tel : +65-6470-2480
Italy	Mitsubishi Electric Europe B.V. Italian Branch Centro Dir. Colleoni, Pal. Perseo-Ingr.2 Via Paracelso 12, I-20041 Agrate Brianza., Milano, Italy Tel : +39-039-60531	Thailand	Mitsubishi Electric Automation (Thailand) Co., Ltd. Bang-Chan Industrial Estate No.111 Moo 4, Serithai Rd, T.Kannayao, A.Kannayao, Bangkok 10230 Thailand Tel : +66-2-517-1326
Spain	Mitsubishi Electric Europe B.V. Spanish Branch Carretera de Rubi 76-80, E-08190 Sant Cugat del Valles, Barcelona, Spain Tel : +34-93-565-3131	Indonesia	P.T. Autoteknindo Sumber Makmur Muara Karang Selatan, Block A/Utara No.1 Kav. No.11 Kawasan Industri Pergudangan Jakarta - Utara 14440, P.O.Box 5045 Jakarta, 11050 Indonesia Tel : +62-21-6630833
France	Mitsubishi Electric Europe B.V. French Branch 25, Boulevard des Bouvets, F-92741 Nanterre Cedex, France Tel : +33-1-5568-5568	India	Messung Systems Pvt, Ltd. Electronic Sadan NO:III Unit No15, M.I.D.C Bhosari, Pune-411026, India Tel : +91-20-2712-3130
South Africa	Circuit Breaker Industries Ltd. Private Bag 2016, ZA-1600 Isando, South Africa Tel : +27-11-928-2000	Australia	Mitsubishi Electric Australia Pty. Ltd. 348 Victoria Road, Rydalmere, N.S.W 2116, Australia Tel : +61-2-9684-7777

### MITSUBISHI ELECTRIC CORPORATION

HEAD OFFICE : TOKYO BUILDING, 2-7-3 MARUNOUCHI, CHIYODA-KU, TOKYO 100-8310, JAPAN  
NAGOYA WORKS : 1-14, YADA-MINAMI 5-CHOME, HIGASHI-KU, NAGOYA, JAPAN

When exported from Japan, this manual does not require application to the Ministry of Economy, Trade and Industry for service transaction permission.