

FX1N

DISPLAY MODULE FX1N-5DM

USER'S MANUAL

JY992D84901F

This manual only describes the specifications for Display Module FX1N-5DM.

For complete operation, wiring, mounting and programming instructions please refer to the FX1S, FX1N HARDWARE MANUAL and PROGRAMMING MANUAL.

These manuals should be read and understood before attempting to install or use the unit.

Related Manuals

| Manual name | Manual No. | Description |
|---------------------------------|-------------|---|
| FX1S Series Hardware Manual | JY992D83901 | Describes contents related to hardware of FX1S Series PLC such as specifications, wiring and installation. (It is offered with FX1S Series PLC basic unit.) |
| FX1N Series Hardware Manual | JY992D88201 | Describes contents related to hardware of FX1N Series PLC such as specifications, wiring and installation. (It is offered with FX1N Series PLC basic unit.) |
| FX Series Programming Manual II | JY992D88101 | Describes instructions in FX1S/FX1N/FX2N/FX2NC Series. |

1. Outline of Product

1.1 Features

The micro display module FX1N-5DM (hereafter referred to as "5DM") is mounted on the top face of the FX1S/FX1N Series PLC basic unit and can monitor/update internal PLC data.

PLCs installed to: FX1S and FX1N Series

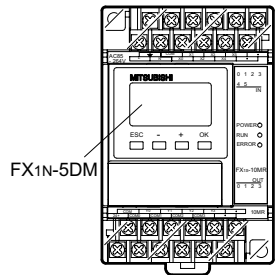

1.2 Product configuration

Main unit : FX1N-5DM

Accessories : Top cover for DM 1, M3 screw to mount top cover 1

1.3 Outside dimensions

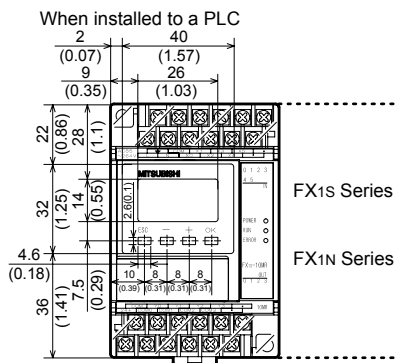
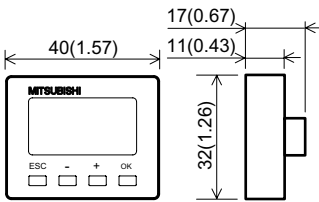

Note: These dimensions measured from the left side are common to the FX1S and FX1N Series.

Unit: mm (inches)

Outer painting color: Munsell 0.08GY/7.64/0.81

Mass: 20 g (0.05 lbs)

1.4 Name of each part

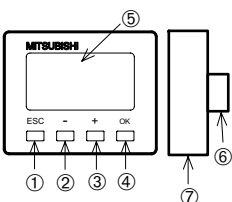

- ① ESC key: Cancels the last key operation or returns to the previous screen.
- ② "-" key: Scrolls the device No. to a smaller one or decrements a numeric value by.
- ③ "+" key: Scrolls the device No. to a larger one or increments a numeric value.
- ④ OK key: Determines the display device, executes write of a numeric value, or changes over forced setting and forced resetting.
- ⑤ Display area: Displays the current time and the monitored device status.
- ⑥ Connector for PLC
- ⑦ 5DM mounting hook

2. Installation

Install the 5DM to the PLC using the following procedure.

- A) Top cover for DM (offered as an accessory of 5DM)
- B) Connector for optional equipment
- C) M3 screw to fix top cover

- Remove the top cover of the basic unit, and attach the top cover for DM A) instead.
Plug the 5DM in to the connector B).
- If the 5DM is always used, the top cover can be fixed with the M3 screw C). (Tightening torque: 0.3 to 0.6 N·m)

If the 5DM is used together with a function expansion board, remove and attach the 5DM by pressing the 5DM mounting hook provided at the bottom of the 5DM.

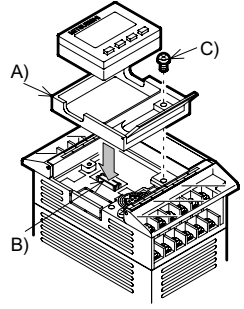

3. Specifications

3.1 Environmental specifications

The environmental specifications are equivalent to those of the PLC main unit. (Refer to the handy manual offered with the FX1S/FX1N Series PLC main unit.)

3.2 Power supply specifications

The power is supplied from the PLC main unit.
5V DC, 110 mA

4. Outline of Performance

This section describes the function list of the 5DM.

The operator functions available with the operation keys of the 5DM are described on the back of this manual. For the 5DM control functions available from the PLC, refer to the FX1S/FX1N/FX2N/FX2NC Series Programming Manual.

4.1 Function list

Symbols stand for the following.

X: Input Y: Output M: Auxiliary relay S: State T: Timer C: Counter D: Data register
BFM: Buffer memory of special units and special blocks

Operator functions: The operator can use these functions by using only the operation keys of the 5DM. Refer to the simplified chart of operations shown on the back face of this manual.

| Function | Description |
|--------------------------------|---|
| Clock function | |
| Display | Displays current time of clock function (built in FX1S/FX1N Series). |
| Setting | Allows to set time (year, month, day, hour and minute). |
| Device monitor function | |
| Bit device monitor | Displays ON/OFF status of X, Y, M and S. |
| Word device (16-bit) monitor | Displays current and set values of T and C and current value of D. |
| Word device (32-bit) monitor | Displays current and set values of 32-bit C and current value of D. |
| Buffer memory monitor function | Displays buffer memory of special units and special blocks (offered only in FX1N Series). |
| Error display function | Displays error code and error occurrence step No. when a PLC error has occurred. |
| Forced set/reset function | Forces ON and OFF bit devices Y, M and S. |
| T/C reset function | Clears current value of T and C (current value: 0, contact: OFF). |
| Data change function | |
| Current value change | Change current value of T, C and D. |
| Set value change | Change set value of T and C. |

5DM control functions: The 5DM is controlled by sequence programs.

For use of these functions, refer to the FX Series Programming Manual II

| Function | Description |
|---|--|
| Protect function | Enables full use of all operator functions, enables only monitor function or enables only clock time display function. |
| Specified device monitor function | Allows to specify device type and device No. to be displayed in 5DM. |
| Error display enable/disable function | Enables or disables error display function (operator function). |
| Automatic backlight OFF function | Allows to set automatic backlight OFF time (initial value: 10 min). |
| Operation key status recognition function | Recognizes ON/OFF status of four operation keys. |

Cautions:

- 1) If a keyword to prohibit read, write or read and write of programs is registered in the PLC, only the clock time display function is available. Any other function shown above is not available.
If any operation is performed in the 5DM when a keyword is registered in the PLC, the error display flickers for 5 seconds.
- 2) The automatic backlight OFF function is set to 10 minutes as the initial value. As far as the OFF time is not changed by a sequence program, the backlight turns off 10 minutes later.
If any key is pressed after the backlight turns off, the contents displayed just before the backlight turns off appear again. A key pressed for the first time after the backlight turns off is regarded as a trigger to turn on the backlight, and is not regarded as a key operation.

4.2 Control devices for 5DM

When using the 5DM control function, specify data registers (D) and auxiliary relays (M) used to control the 5DM to special data registers D8158 and D8159.

Five data registers and 15 auxiliary relays are occupied for control of the 5DM.

For the control device use procedure, refer to the FX1S/FX1N/FX2N/FX2NC Series Programming Manual.

| Special D | Control device | Description | Application |
|-------------|----------------|---|---------------------------------------|
| D8158 K0 | DO | Device type to be displayed *1 | For specified device monitor function |
| | DO+1 | Device No. to be displayed | |
| | DO+2 | Backlight OFF time (min) | For automatic backlight OFF function |
| | DO+3 | Protects display screen. *2 | For protect function |
| | DO+4 | Not available. | |
| D8159 K0 | M0 | Requests edition of displayed device data. | For specified device monitor function |
| | M0+1 | Edition completion response | |
| | M0+2 | Disables backlight OFF function. (Turns on backlight forcibly.) | For automatic backlight OFF function |
| | M0+3 | Displays or hides operation errors, etc. *3 | Others |
| | M0+4 | ESC key status *4 | For specified device monitor function |
| | M0+5 | "-" key status *4 | |
| | M0+6 | "+" key status *4 | |
| | M0+7 | OK key status *4 | |
| | M0+8 | Not available. | |
| | M0+9 | Not available. | |
| | M0+10 | Not available. | |
| | M0+11 | Not available. | |
| | M0+12 | Not available. | |
| | M0+13 | Not available. | |
| M0+14 | Not available. | | |

*1 Input numeric values correspond to the devices as follows.

- 1: Input (X) 2: Output (Y) 3: Auxiliary relay (M) 4: State (S) 5: Timer (T)
6: Counter (C), 16-bit (current value/set value) and 32-bit (set value)
7: Data register (D), 16-bit 8: Data register (D), 32-bit 9: Time display
10: Counter (C), 16-bit (current value/set value) and 32-bit (current value)

*2 0: Enables all operations. 1: Enables only the time display function.

2: Enables only the monitor function.

*3 PC hardware errors, parameter errors, grammatical errors and circuit errors are unconditionally displayed. While this bit is ON, I/O configuration errors, parallel link errors and operation errors are also displayed.

*4 Every operation key is the momentary type, and functions as follows:

While a key is pressed and held: ON

While key is not pressed: OFF

4.3 Description on display area

The display area of the 5DM shows the following.

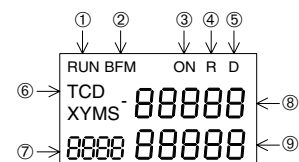

- ① "RUN": Displayed while the PLC is running, and not displayed while the PLC is stopped.
- ② "BFM": Displays the contents of the buffer memory when a special block is connected (only in the FX1N Series).
- ③ "ON/OFF": Displayed while T or C is ON in the word device monitor function, and not displayed while T or C is OFF.
- ④ "R" (reset): Displayed while T or C is reset.
- ⑤ "D" (32-bit): Displayed when a 32-bit D is specified.
- ⑥ Device type: Displays the device type (T, C, D, X, Y, M or S) currently being displayed.
- ⑦ Device No.: Displays the device No. currently being displayed.
- ⑧ Current value: Displays the current value of T, C or D.
- ⑨ Set value: Displays the set value of T or C.

* In the case of 32-bit C or D, upper 5 digits are displayed in ⑧ and the lower 5 digits are displayed in ⑨.

5. Operation List

The process for the operator functions are shown below.

- The operation keys are expressed as follows.

ESC : ESC key - : "-" key + : "+" key OK : OK key

Time display screen (when the power is turned on)

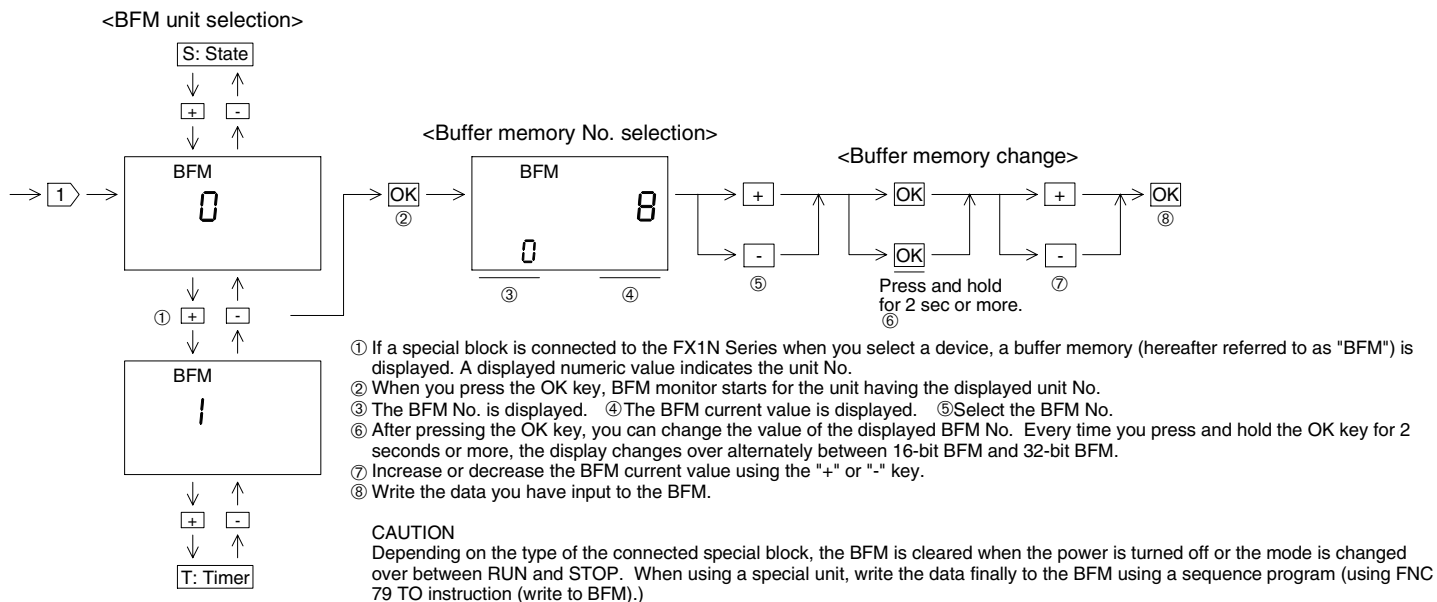
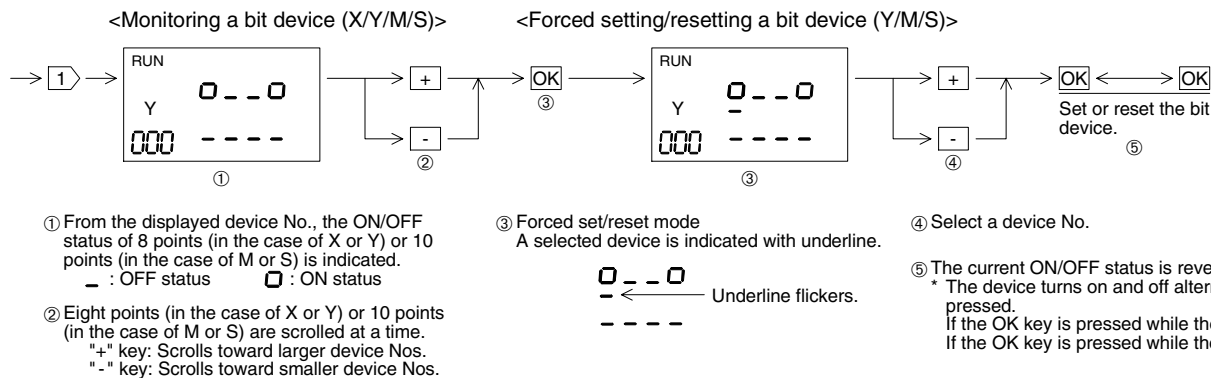
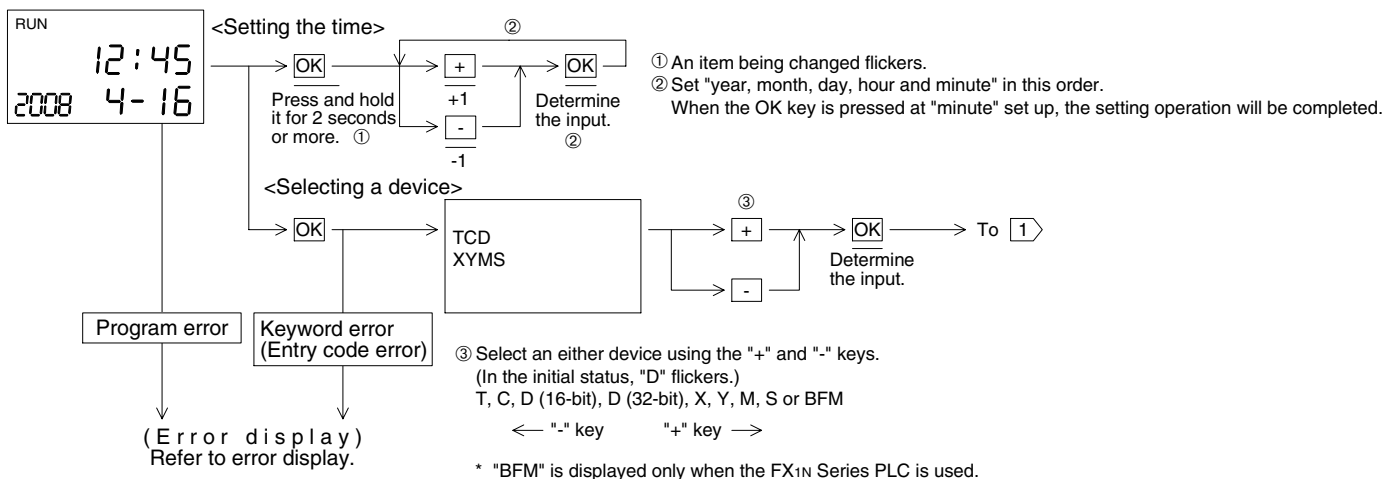

Guidelines for the safety of the user and protection of the Micro Display Module FX1N-5DM

- This manual has been written to be used by trained and competent personnel. This is defined by the European directives for machinery, low voltage and EMC.
- If in doubt at any stage during the installation of the Micro Display Module FX1N-5DM always consult a professional electrical engineer who is qualified and trained to the local and national standards. If in doubt about the operation or use of the Micro Display Module FX1N-5DM please consult the nearest Mitsubishi Electric distributor.
- Under no circumstances will Mitsubishi Electric be liable or responsible for any consequential damage that may arise as a result of the installation or use of this equipment.
- All examples and diagrams shown in this manual are intended only as an aid to understanding the text, not to guarantee operation. Mitsubishi Electric will accept no responsibility for actual use of the product based on these illustrative examples.
- Owing to the very great variety in possible application of this equipment, you must satisfy yourself as to its suitability for your specific application.

Attention

- This product is designed for use in industrial applications.

Note

- Manufactured by: Mitsubishi Electric Corporation
2-7-3 Marunouchi, Chiyoda-ku, Tokyo, 100-8310 Japan
- Manufactured at: Mitsubishi Electric Corporation Himeji Works
840 Chiyoda-machi, Himeji, Hyogo, 670-8677 Japan
- Authorized Representative in the European Community:
Mitsubishi Electric Europe B.V.
Gothaer Str. 8, 40880 Ratingen, Germany

<Monitoring 16-bit T or 16-bit C >

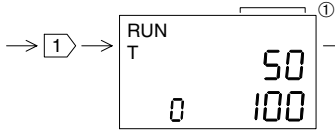

<Changing the current value/set value of 16-bit T or 16-bit C >

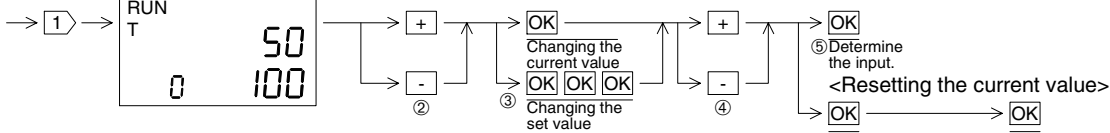

- ① "ON" is displayed when T or C is ON and "R" is displayed while resetting.
- ② Change over the device to monitor.
T or C that is not used in the program is not displayed.
(A horizontal line "-" is displayed if there is none of T or C in the program.)
- ③ When the OK key is pressed once, the current value is changed, and when the OK key is pressed three times, the set value is changed. (Flickers while changing)
- ④ Press the "+" key to increase the value. Press the "-" key to decrease the value.
- ⑤ Press the OK key to determine the input. At this time, the input data is written to the PLC.
- ⑥ When the OK key is pressed and held for 2 seconds or more while the current value is changed, the current value is reset to "0" and the contact turns off.
When the OK key is pressed once again, the current value reset operation will be completed.

<Monitoring 32-bit C >

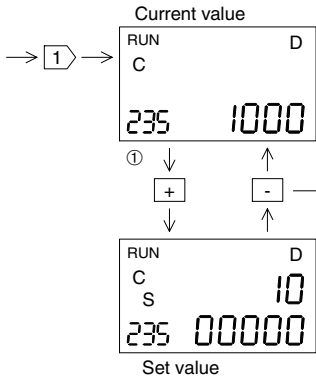

<Changing the current set value of 32-bit C >

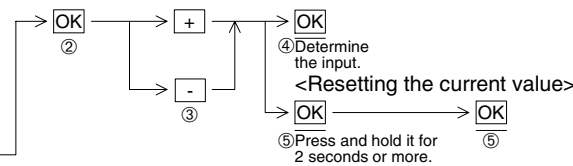

- ① Press the "+" or "-" key to change over the current value and the set value. For the set value, "S" is added in a right position above the device No.
- ② When the OK key is pressed, the current value or the set value is changed.
- ③ Press the "+" key to increase the value. Press the "-" key to decrease the value.
- ④ Press the OK key to determine the input. At this time, the input data is written to the PLC.
- ⑤ When the OK key is pressed and held for 2 seconds or more while the current value is changed, the current value is reset to "0" and the contact turns off.
When the OK key is pressed once again, the current value reset operation will be completed.

<Monitoring 16-bit D >

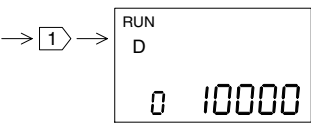

<Changing the current value of 16-bit D >

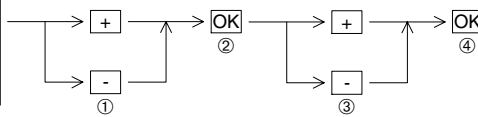

- ① D is scrolled by 1 point at a time.
- ② Select the current value change mode.
- ③ Press the "+" key to increase the value. Press the "-" key to decrease the value.
- ④ Press the OK key to determine the input. At this time, the input data is written to the PLC.

<Monitoring 32-bit D >

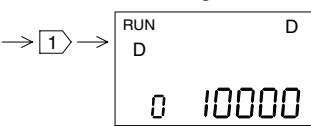

<Changing the current value of 32-bit D >

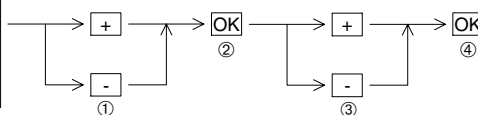

- ① D is scrolled by 2 points at a time by the "+" key and by 1 point at a time by the "-" key.
- ② Select the current value change mode.
- ③ Press the "+" key to increase the value. Press the "-" key to decrease the value.
- ④ Press the OK key to determine the input. At this time, the input data is written to the PLC.

<Error display >

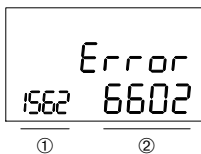

- ① Error step No.
 - ② Error code
- Press the ESC key or release the error status to delete the error display.

<Keyword (Entry code) error display >

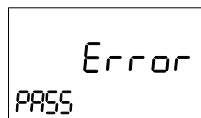

When an keyword (entry code) has been input to the PLC, only the time can be displayed.
If you press the OK key while the time is displayed, the error message shown on the left flickers for 5 seconds.
Release the keyword (entry code) in a peripheral unit such as the FX-10P/20P and the personal computer software for creating sequence programs.

Manual number : JY992D84901

Manual revision : F

Date : October 2010

MITSUBISHI ELECTRIC CORPORATION

HEAD OFFICE : TOKYO BUILDING, 2-7-3 MARUNOUCHI, CHIYODA-KU, TOKYO 100-8310 JAPAN
HIMEJI WORKS : 840, CHIYODA CHO, HIMEJI, JAPAN

JY992D84901F

Effective October 2010

Specifications are subject to change without notice

This manual confers no industrial property rights or any rights of any other kind, nor does it confer any patent licenses. Mitsubishi Electric Corporation cannot be held responsible for any problems involving industrial property rights which may occur as a result of using the contents noted in this manual.

FX1N

DISPLAY MODULE FX1N-5DM

USER'S MANUAL

JY992D84901F

This manual only describes the specifications for Display Module FX1N-5DM.

For complete operation, wiring, mounting and programming instructions please refer to the FX1S, FX1N HARDWARE MANUAL and PROGRAMMING MANUAL.

These manuals should be read and understood before attempting to install or use the unit.

Related Manuals

| Manual name | Manual No. | Description |
|---------------------------------|-------------|---|
| FX1S Series Hardware Manual | JY992D83901 | Describes contents related to hardware of FX1S Series PLC such as specifications, wiring and installation. (It is offered with FX1S Series PLC basic unit.) |
| FX1N Series Hardware Manual | JY992D88201 | Describes contents related to hardware of FX1N Series PLC such as specifications, wiring and installation. (It is offered with FX1N Series PLC basic unit.) |
| FX Series Programming Manual II | JY992D88101 | Describes instructions in FX1S/FX1N/FX2N/FX2NC Series. |

1. Outline of Product

1.1 Features

The micro display module FX1N-5DM (hereafter referred to as "5DM") is mounted on the top face of the FX1S/FX1N Series PLC basic unit and can monitor/update internal PLC data.

PLCs installed to: FX1S and FX1N Series

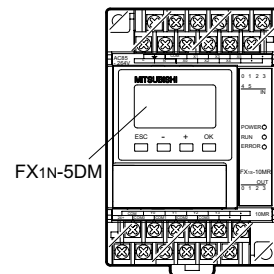

1.2 Product configuration

Main unit : FX1N-5DM

Accessories : Top cover for DM 1, M3 screw to mount top cover 1

1.3 Outside dimensions

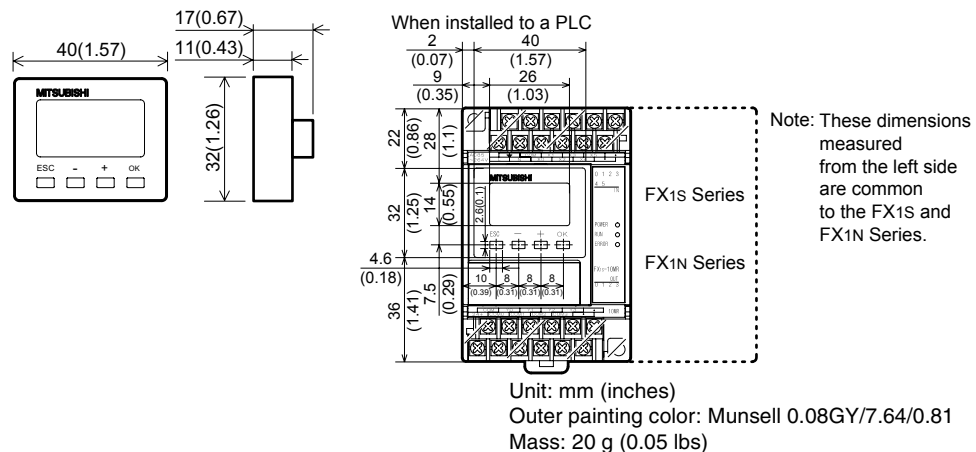

1.4 Name of each part

-
- ESC key: Cancels the last key operation or returns to the previous screen.
 - "-" key: Scrolls the device No. to a smaller one or decrements a numeric value by.
 - "+" key: Scrolls the device No. to a larger one or increments a numeric value.
 - OK key: Determines the display device, executes write of a numeric value, or changes over forced setting and forced resetting.
 - Display area: Displays the current time and the monitored device status.
 - Connector for PLC
 - 5DM mounting hook

2. Installation

Install the 5DM to the PLC using the following procedure.

- Top cover for DM (offered as an accessory of 5DM)
- Connector for optional equipment
- M3 screw to fix top cover

- Remove the top cover of the basic unit, and attach the top cover for DM A) instead. Plug the 5DM in to the connector B).
- If the 5DM is always used, the top cover can be fixed with the M3 screw C). (Tightening torque: 0.3 to 0.6 N·m)

If the 5DM is used together with a function expansion board, remove and attach the 5DM by pressing the 5DM mounting hook provided at the bottom of the 5DM.

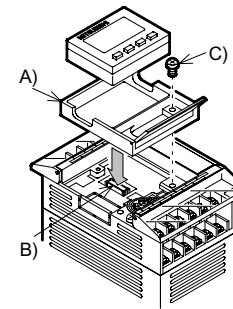

3. Specifications

3.1 Environmental specifications

The environmental specifications are equivalent to those of the PLC main unit. (Refer to the handy manual offered with the FX1S/FX1N Series PLC main unit.)

3.2 Power supply specifications

The power is supplied from the PLC main unit.
5V DC, 110 mA

4. Outline of Performance

This section describes the function list of the 5DM.

The operator functions available with the operation keys of the 5DM are described on the back of this manual. For the 5DM control functions available from the PLC, refer to the FX1S/FX1N/FX2N/FX2NC Series Programming Manual.

4.1 Function list

Symbols stand for the following.

X: Input Y: Output M: Auxiliary relay S: State T: Timer C: Counter D: Data register
BFM: Buffer memory of special units and special blocks

Operator functions: The operator can use these functions by using only the operation keys of the 5DM. Refer to the simplified chart of operations shown on the back face of this manual.

| Function | Description |
|--------------------------------|---|
| Clock function | Display: Displays current time of clock function (built in FX1S/FX1N Series). |
| | Setting: Allows to set time (year, month, day, hour and minute). |
| Device monitor function | Bit device monitor: Displays ON/OFF status of X, Y, M and S. |
| | Word device (16-bit) monitor: Displays current and set values of T and C and current value of D. |
| | Word device (32-bit) monitor: Displays current and set values of 32-bit C and current value of D. |
| Buffer memory monitor function | Displays buffer memory of special units and special blocks (offered only in FX1N Series). |
| Error display function | Displays error code and error occurrence step No. when a PLC error has occurred. |
| Forced set/reset function | Forces ON and OFF bit devices Y, M and S. |
| T/C reset function | Clears current value of T and C (current value: 0, contact: OFF). |
| Data change function | Current value change: Change current value of T, C and D. |
| | Set value change: Change set value of T and C. |

5DM control functions: The 5DM is controlled by sequence programs.

For use of these functions, refer to the FX Series Programming Manual II

| Function | Description |
|---|--|
| Protect function | Enables full use of all operator functions, enables only monitor function or enables only clock time display function. |
| Specified device monitor function | Allows to specify device type and device No. to be displayed in 5DM. |
| Error display enable/disable function | Enables or disables error display function (operator function). |
| Automatic backlight OFF function | Allows to set automatic backlight OFF time (initial value: 10 min). |
| Operation key status recognition function | Recognizes ON/OFF status of four operation keys. |

Cautions:

- If a keyword to prohibit read, write or read and write of programs is registered in the PLC, only the clock time display function is available. Any other function shown above is not available. If any operation is performed in the 5DM when a keyword is registered in the PLC, the error display flickers for 5 seconds.
- The automatic backlight OFF function is set to 10 minutes as the initial value. As far as the OFF time is not changed by a sequence program, the backlight turns off 10 minutes later. If any key is pressed after the backlight turns off, the contents displayed just before the backlight turns off appear again. A key pressed for the first time after the backlight turns off is regarded as a trigger to turn on the backlight, and is not regarded as a key operation.

4.2 Control devices for 5DM

When using the 5DM control function, specify data registers (D) and auxiliary relays (M) used to control the 5DM to special data registers D8158 and D8159.

Five data registers and 15 auxiliary relays are occupied for control of the 5DM.

For the control device use procedure, refer to the FX1S/FX1N/FX2N/FX2NC Series Programming Manual.

| Special D | Control device | Description | Application |
|-------------|----------------|---|---------------------------------------|
| D8158 KO | DO | Device type to be displayed *1 | For specified device monitor function |
| | DO+1 | Device No. to be displayed | |
| | DO+2 | Backlight OFF time (min) | For automatic backlight OFF function |
| | DO+3 | Protects display screen. *2 | For protect function |
| | DO+4 | Not available. | |
| D8159 K□ | M□ | Requests edition of displayed device data. | For specified device monitor function |
| | M□+1 | Edition completion response | |
| | M□+2 | Disables backlight OFF function. (Turns on backlight forcedly.) | For automatic backlight OFF function |
| | M□+3 | Displays or hides operation errors, etc. *3 | Others |
| | M□+4 | ESC key status *4 | For specified device monitor function |
| | M□+5 | "-" key status *4 | |
| | M□+6 | "+" key status *4 | |
| | M□+7 | OK key status *4 | |
| | M□+8 | Not available. | |
| | M□+9 | Not available. | |
| | M□+10 | Not available. | |
| | M□+11 | Not available. | |
| | M□+12 | Not available. | |
| | M□+13 | Not available. | |
| M□+14 | Not available. | | |

*1 Input numeric values correspond to the devices as follows.

- Input (X)
- Output (Y)
- Auxiliary relay (M)
- State (S)
- Timer (T)
- Counter (C), 16-bit (current value/set value) and 32-bit (set value)
- Data register (D), 16-bit/8: Data register (D), 32-bit
- Time display
- Counter (C), 16-bit (current value/set value) and 32-bit (current value)

*2 0: Enables all operations. 1: Enables only the time display function.
2: Enables only the monitor function.

*3 PC hardware errors, parameter errors, grammatical errors and circuit errors are unconditionally displayed. While this bit is ON, I/O configuration errors, parallel link errors and operation errors are also displayed.

*4 Every operation key is the momentary type, and functions as follows:
While a key is pressed and held: ON
While key is not pressed: OFF

4.3 Description on display area

The display area of the 5DM shows the following.

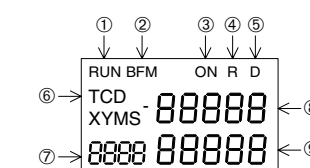

- "RUN": Displayed while the PLC is running, and not displayed while the PLC is stopped.
- "BFM": Displays the contents of the buffer memory when a special block is connected (only in the FX1N Series).
- "ON/OFF": Displayed while T or C is ON in the word device monitor function, and not displayed while T or C is OFF.
- "R" (reset): Displayed while T or C is reset.
- "D" (32-bit): Displayed when a 32-bit D is specified.
- Device type: Displays the device type (T, C, D, X, Y, M or S) currently being displayed.
- Device No.: Displays the device No. currently being displayed.
- Current value: Displays the current value of T, C or D.
- Set value: Displays the set value of T or C.

* In the case of 32-bit C or D, upper 5 digits are displayed in ⑧ and the lower 5 digits are displayed in ⑨.

5. Operation List

The process for the operator functions are shown below.

- The operation keys are expressed as follows.

ESC : ESC key - : "-" key + : "+" key OK : OK key

Time display screen (when the power is turned on)

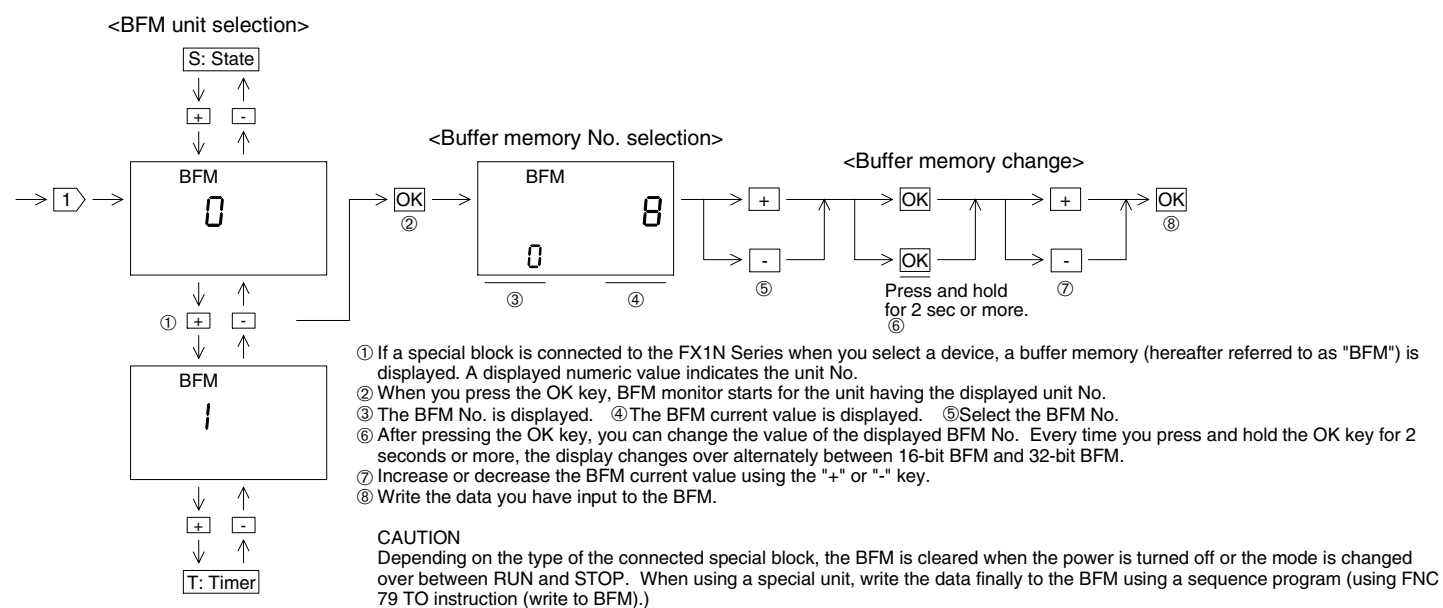
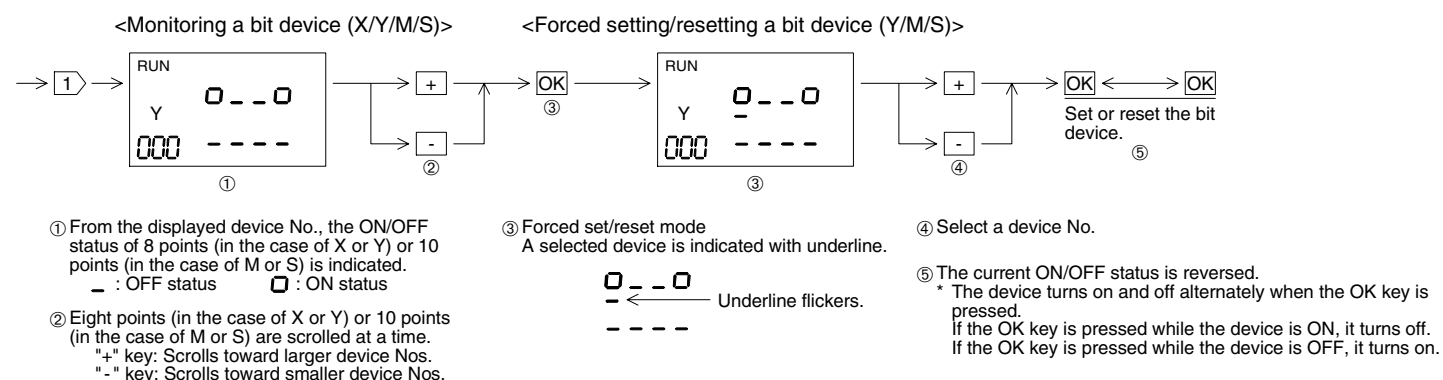
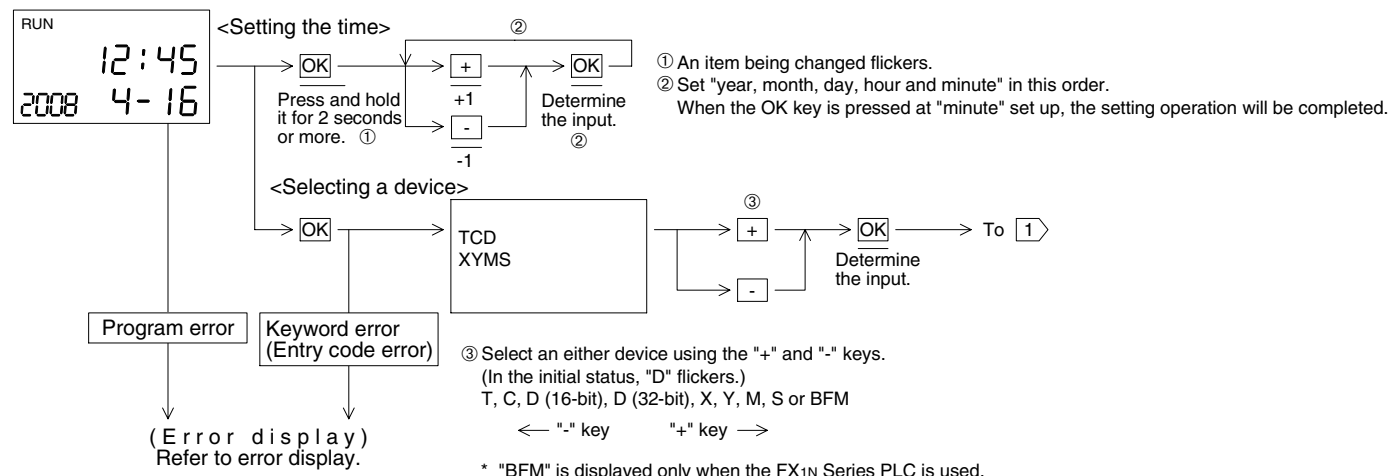

Guidelines for the safety of the user and protection of the Micro Display Module FX1N-5DM

- This manual has been written to be used by trained and competent personnel. This is defined by the European directives for machinery, low voltage and EMC.
- If in doubt at any stage during the installation of the Micro Display Module FX1N-5DM always consult a professional electrical engineer who is qualified and trained to the local and national standards. If in doubt about the operation or use of the Micro Display Module FX1N-5DM please consult the nearest Mitsubishi Electric distributor.
- Under no circumstances will Mitsubishi Electric be liable or responsible for any consequential damage that may arise as a result of the installation or use of this equipment.
- All examples and diagrams shown in this manual are intended only as an aid to understanding the text, not to guarantee operation. Mitsubishi Electric will accept no responsibility for actual use of the product based on these illustrative examples.
- Owing to the very great variety in possible application of this equipment, you must satisfy yourself as to its suitability for your specific application.

Attention

- This product is designed for use in industrial applications.

Note

- Manufactured by: Mitsubishi Electric Corporation
2-7-3 Marunouchi, Chiyoda-ku, Tokyo, 100-8310 Japan
- Manufactured at: Mitsubishi Electric Corporation Himeji Works
840 Chiyoda-machi, Himeji, Hyogo, 670-8677 Japan
- Authorized Representative in the European Community:
Mitsubishi Electric Europe B.V.
Gothaer Str. 8, 40880 Ratingen, Germany

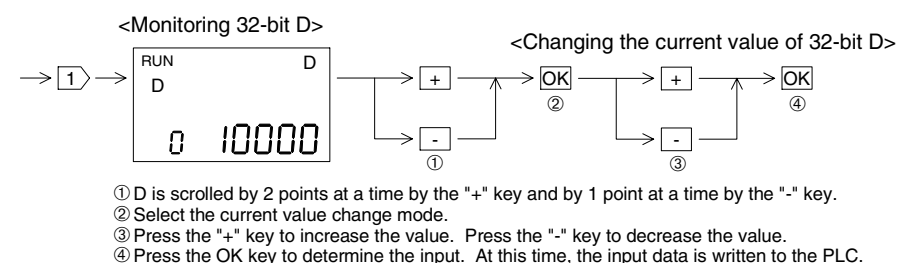
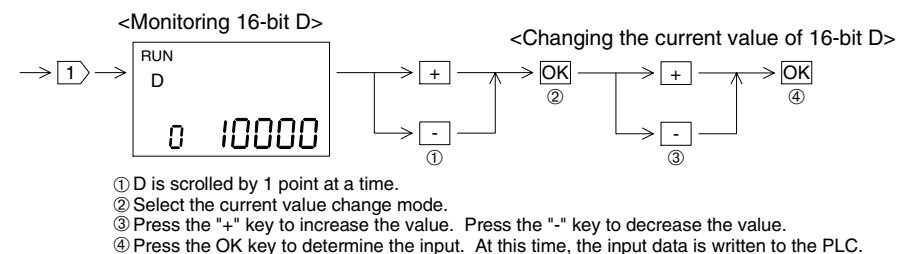
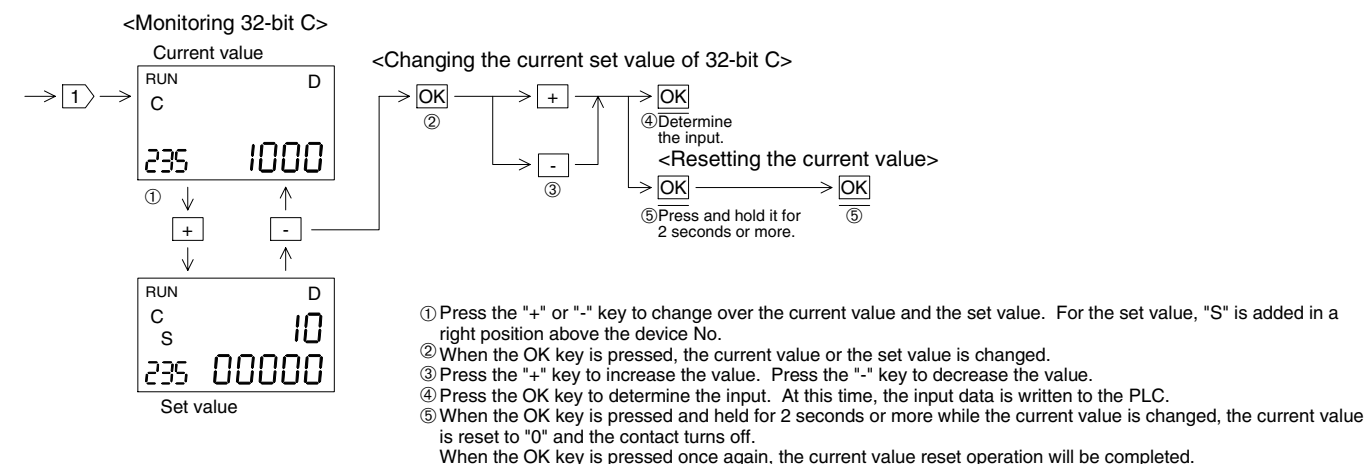
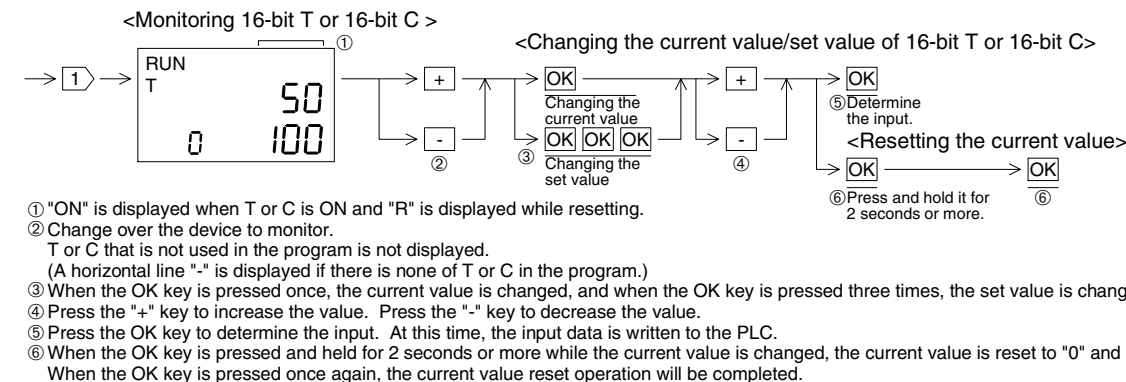

<Error display>

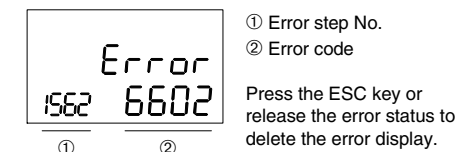

<Keyword (Entry code) error display>

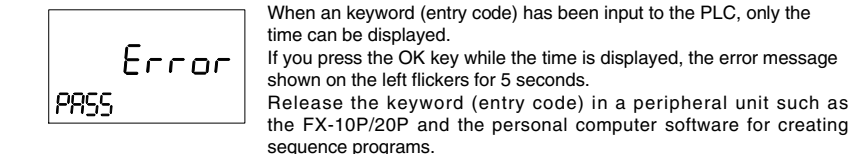

Manual number : JY992D84901

Manual revision : F

Date : October 2010

MITSUBISHI ELECTRIC CORPORATION

HEAD OFFICE : TOKYO BUILDING, 2-7-3 MARUNOUCHI, CHIYODA-KU, TOKYO 100-8310 JAPAN
HIMEJI WORKS : 840, CHIYODA CHO, HIMEJI, JAPAN

JY992D84901F

Effective October 2010

Specifications are subject to change without notice

This manual confers no industrial property rights or any rights of any other kind, nor does it confer any patent licenses. Mitsubishi Electric Corporation cannot be held responsible for any problems involving industrial property rights which may occur as a result of using the contents noted in this manual.