



**FX3U-CF-ADP**

**INSTALLATION MANUAL**

Manual Number	JY997D35201
Revision	B
Date	September 2010

This manual describes the part names, dimensions, mounting, and specifications of the product. Before use, read this manual and the manuals of all relevant products fully to acquire proficiency in handling and operating the product. Make sure to learn all the product information, safety information, and precautions. Store this manual in a safe place so that it can be taken out and read whenever necessary. Always forward it to the end user.

Registration: CompactFlash is a trademark of SanDisk Corporation in the United States and other countries.

The company and product names described in this manual are registered trademarks or the trademarks of their respective companies.

Effective September 2010  
 Specifications are subject to change without notice.

© 2009 Mitsubishi Electric Corporation

**Safety Precaution** (Read these precautions before use.)

This manual classifies the safety precautions into two categories:

⚠ **DANGER** and ⚠ **CAUTION**.

<b>DANGER</b>	Indicates that incorrect handling may cause hazardous conditions, resulting in death or severe injury.
<b>CAUTION</b>	Indicates that incorrect handling may cause hazardous conditions, resulting in medium or slight personal injury or physical damage.

Depending on the circumstances, procedures indicated by **CAUTION** may also cause severe injury. It is important to follow all precautions for personal safety.

**Associated Manuals**

Manual name	Manual No.	Description
FX3U-CF-ADP User's Manual	JY997D35401 MODEL CODE: 09R720	Describes details of the FX3U-CF-ADP CF card special adapter.
FX3G/FX3U/FX3UC Series Programming Manual - Basic & Applied Instruction Edition	JY997D16601 MODEL CODE: 09R517	Describes PLC programming for basic/applied instructions and devices.
FX3U Series User's Manual - Hardware Edition	JY997D16501 MODEL CODE: 09R516	Explains the FX3U Series PLC specifications for I/O, wiring, installation, and maintenance.
FX3UC Series User's Manual - Hardware Edition	JY997D28701 MODEL CODE: 09R519	Explains the FX3UC Series PLC specifications for I/O, wiring, installation, and maintenance.

**How to obtain manuals**

For product manuals or documents, consult with the Mitsubishi Electric dealer from who you purchased your product.

**Certification of UL, cUL standards**

FX3U-CF-ADP units comply with the UL standards (UL, cUL).  
 UL, cUL File Number: E95239

Regarding the standards that comply with the main unit, please refer to either the FX series product catalog or consult with your nearest Mitsubishi product provider.

**Compliance with EC directive (CE Marking)**

This note does not guarantee that an entire mechanical module produced in accordance with the contents of this note will comply with the following standards. Compliance to EMC directive and LVD directive for the entire mechanical module should be checked by the user / manufacturer. For more information please consult with your nearest Mitsubishi product provider.

Regarding the standards that comply with the main unit, please refer to either the FX series product catalog or consult with your nearest Mitsubishi product provider.

**Attention**

- This product is designed for use in industrial applications.

**Note**

- Manufactured by: Mitsubishi Electric Corporation  
 2-7-3 Marunouchi, Chiyoda-ku, Tokyo, 100-8310 Japan
- Manufactured at: Mitsubishi Electric Corporation Himeji Works  
 840 Chiyoda-machi, Himeji, Hyogo, 670-8677 Japan
- Authorized Representative in the European Community:  
 Mitsubishi Electric Europe B.V.  
 Gothaer Str. 8, 40880 Ratingen, Germany

**Requirement for Compliance with EMC directive**

The following products have shown compliance through direct testing (of the identified standards below) and design analysis (through the creation of a technical construction file) to the European Directive for Electromagnetic Compatibility (2004/108/EC) when used as directed by the appropriate documentation.

Type: Programmable Controller (Open Type Equipment)

Models: MELSEC FX3U series manufactured

from June 1st, 2009 FX3U-CF-ADP

Standard	Remark
EN61131-2:2007 Programmable controllers - Equipment requirements and tests	Compliance with all relevant aspects of the standard. <b>EMI</b> • Radiated Emissions • Conducted Emissions <b>EMS</b> • Radiated electromagnetic field • Fast Transient burst • Electrostatic discharge • High-energy surge • Voltage drops and interruptions • Conducted RF • Power frequency magnetic field

**Caution for EC Directive**

- Installation in Enclosure  
 Programmable logic controllers are open-type devices that must be installed and used within conductive control cabinets. Please use the programmable logic controller while installed within a conductive shielded control cabinet. Please secure the cabinet door to the control cabinet (for conduction). Installation within a control cabinet greatly affects the safety of the system and aids in shielding noise from the programmable logic controller.
- Control cabinet  
 - The control cabinet must be conductive.  
 - Ground the control cabinet with the thickest possible grounding cable.  
 - To ensure that there is electric contact between the control cabinet and its door, connect the cabinet and its doors with thick wires.  
 - In order to suppress the leakage of radio waves, the control cabinet structure must have minimal openings. Also, wrap the cable holes with a shielding cover or other shielding devices.  
 - The gap between the control cabinet and its door must be as small as possible by attaching EMI gaskets between them.

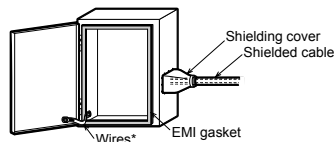

\* These wires are used to improve the conductivity between the door and control cabinet.

**1. Introduction**

The CF card special adapter FX3U-CF-ADP (hereinafter abbreviated as "CF-ADP") stores data to and reads data from the CompactFlash™ card (CF card) in accordance with applied instructions for the CF-ADP sent from the FX3U/FX3UC PLC.

Data is stored in CSV format on the CompactFlash™ card.  
 Only one CF-ADP unit can be connected to a single main unit.

For system configuration, refer to the following manual.

→ **FX3U-CF-ADP User's Manual**

**1.1 Function outline**

- Data can be saved in the CompactFlash™ card in files with the FIFO (first in, first out) function.
- Data can be saved in a specified file stored in the CompactFlash™ card.
- Data can be read from the CompactFlash™ card.

**1.2 Incorporated Items**

Check to ensure the following product and items are included in the package:

Product	FX3U-CF-ADP CF card special adapter
Accessories	FX2NC-100MPCB Power supply cable [1m (3'3")] x 1 sheet Dust proof protection sheet x 1 sheet Installation manual (This manual)

**1.3 External Dimensions and Part Names**

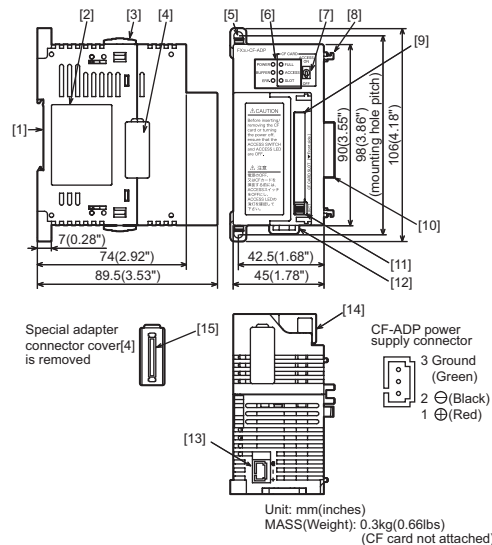

- |  |                                    |
|--|------------------------------------|
| [1] DIN rail mounting groove (DIN rail: DIN46277, 35mm (1.38") width)              | [10] Special adapter connector     |
| [2] Nameplate  | [11] EJECT button                  |
| [3] Special adapter slide hook   | [12] DIN rail mounting hook        |
| [4] Special adapter connector cover  | [13] CF-ADP power supply connector |
| [5] Direct mounting hole (2 holes of $\phi$ 4.5 (0.18") (mounting screw: M4 screw) | [14] CF card cover                 |
| [6] Status LEDs  | [15] Special adapter connector     |
| [7] CF card ACCESS switch  |                                    |
| [8] Special adapter fixing hook  |                                    |
| [9] CF card slot   |                                    |

**1.4 Power and status LEDs**

LED display	LED color	Status	Description
POWER	Green	OFF	Power is not being supplied from the external power supply (24V DC).
		ON	Power is being supplied from the external power supply (24V DC).
BUFFER	Green	OFF	Data is not stored in the internal buffer.
		ON	Data is stored in the internal buffer.
ERR.	Red	OFF	No errors.
		ON	CF write error, CompactFlash™ card error, etc. has occurred.
FULL	Red	OFF	The CompactFlash™ card has free space.
		Flicker	The free space in the CompactFlash™ card is 20% or less of the full capacity.
		ON	The CompactFlash™ card has no free space. The free space in the CompactFlash™ card is 1% or less of the full capacity.
ACCESS	Green	OFF	CompactFlash™ card not accessed.
		ON	CompactFlash™ card accessed.
SLOT	Green	OFF	The CompactFlash™ card is not inserted, or the slot is in the CompactFlash™ card unmounted status.
		ON	The CompactFlash™ card is inserted, or the slot is in the card mounted status.

**2. Installation**

For installation details, refer to the following manuals.

→ **Refer to the FX3U-CF-ADP User's Manual.**

**INSTALLATION PRECAUTIONS** ⚠ **DANGER**

- Make sure to shut down all phases of the power supply externally before installing the CF-ADP. Failure to do so may cause electric shock or damage to the product.

**INSTALLATION PRECAUTIONS** ⚠ **CAUTION**

- Use the product within the generic environment specifications described in PLC main unit manual (Hardware Edition). Never use the product in areas with excessive dust, oily smoke, conductive dusts, corrosive gas (salt air, Cl<sub>2</sub>, H<sub>2</sub>S, SO<sub>2</sub>, or NO<sub>2</sub>), flammable gas, vibration or impacts, or expose it to high temperature, condensation, or rain and wind. If the product is used in such conditions, electric shock, fire, malfunctions, deterioration or damage may occur.
- Do not touch the conductive parts of the product directly. Doing so may cause device failures or malfunctions.
- Install the product securely using a DIN rail or mounting screws.
- Install the product on a flat surface. If the mounting surface is rough, undue force will be applied to the PC board, thereby causing nonconformities.
- When drilling screw holes or wiring, make sure that cutting and wiring debris do not enter the ventilation slits. Failure to do so may cause fire, equipment failures or malfunctions.
- Be sure to remove the dust proof sheet from the PLC's ventilation port when installation work is completed. Failure to do so may cause fire, equipment failures or malfunctions.
- Connect the CF-ADP securely to special adapter connector. Loose connections may cause malfunctions.
- Connect the power connector of the power supply cable securely to the CF-ADP power supply connector. Loose connections may cause malfunctions.
- When inserting a CompactFlash™ card into the CF-ADP, push it into the CF card slot until the EJECT button pops out. Loose connections may cause malfunctions.

**INSTALLATION PRECAUTIONS** **CAUTION**

- Before inserting/removing a CompactFlash™ card into/from the CF-ADP, set the CF card ACCESS switch to OFF and confirm that the BUFFER LED and ACCESS LED are both OFF.
- Failure to do so may corrupt data within the CompactFlash™ card.
- When removing a CompactFlash™ card from the CF-ADP, make sure to support the CompactFlash™ card by hand, as it may pop out.
- Failure to do so may cause the CompactFlash™ card to fall from the CF-ADP and break.

### 2.1 Connection with PLC

Only one CF-ADP can be connected to the left side of a PLC main unit or special adapter.  
An expansion board is necessary to connect the CF-ADP with the FX3U, FX3UC-32MT-LT PLC.  
For details, refer to the respective PLC manual.  
→ FX3U Series User's Manual - Hardware Edition  
→ FX3UC Series User's Manual - Hardware Edition

### 2.2 Mounting

- The product is mounted by the following method.
- DIN rail mounting
- Direct mounting (mounting screw: M4 screw)

For details, refer to the respective PLC manual.

→ FX3U Series User's Manual - Hardware Edition  
→ FX3UC Series User's Manual - Hardware Edition

### 2.3 Inserting and Removal Procedures

#### 2.3.1 Inserting the CompactFlash™ card

The CompactFlash™ card can be inserted when the CF-ADP is power off.  
When the power supply of CF-ADP is ON and it inserts the CompactFlash™ card, make sure to perform of the following procedures.

- Set the CF card ACCESS switch to OFF (A in the figure on the right) in the CF-ADP. Confirm that the POWER LED is lit.

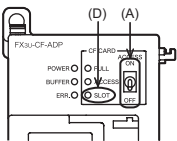

- Open the CF card cover.  
Insert the CompactFlash™ card into the CF card slot with the front side (side B in the figure on the right) facing the right side of the CF-ADP until the EJECT button (side C in the figure on the right) pops out.

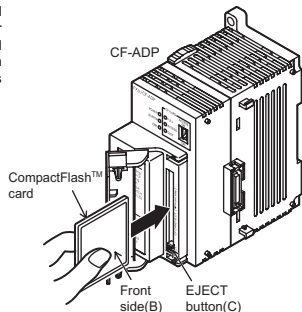

- Close the CF card cover.  
Set the CF card ACCESS switch to ON.

#### 2.3.2 Removing the CompactFlash™ card

The CompactFlash™ card can be removed when the CF-ADP is power off.  
When the power supply of CF-ADP is ON and it removes the CompactFlash™ card, make sure to perform of the following procedures.

- Set the CF card ACCESS switch of the CF-ADP to OFF (A in the figure on the right), and make sure that the CF card ACCESS LED and BUFFER LED (B in the figure on the right) both turn off. (When the CF card ACCESS LED turns off, the CompactFlash™ card can be removed even when the CF-ADP is powering on.)

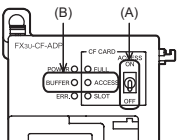

#### CAUTION

When the CF card ACCESS LED is lit or flickering, do not removing the CompactFlash™ card or power off the CF-ADP. Doing so may cause data corruption or malfunction.

- Open the CF card cover.  
Push the EJECT button (C in the figure on the right) of the CF-ADP to push out the CompactFlash™ card and remove it.

#### CAUTION

When ejecting the CompactFlash™ card, support it by hand since it may pop out. Failure to do so may cause the CompactFlash™ card to fall, leading to failure or damage of the card.

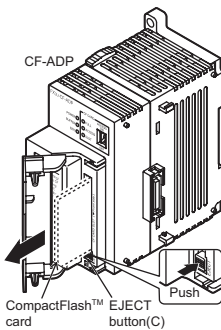

### 3. Specification

For details on specifications, refer to the following manual.

→ FX3U-CF-ADP User's Manual

**DESIGN PRECAUTIONS** **DANGER**

- Make sure to include the following safety circuits outside the PLC to ensure safe system operation even during external power supply problems or PLC failure. Otherwise, malfunctions may cause serious accidents.

- Above all, the following components should be included: an emergency stop circuit, a protection circuit, an interlock circuit for opposite movements (such as normal vs. reverse rotation), and an interlock circuit (to prevent damage to the equipment at the upper and lower positioning limits).
- Note that when the PLC main unit detects an error during self diagnosis, such as a watchdog timer error, all outputs are turned off. Also, when an error that cannot be detected by the PLC main unit occurs in an input/output control block, output control may be disabled. External circuits and mechanisms should be designed to ensure safe machinery operation in such cases.

**DESIGN PRECAUTIONS** **CAUTION**

- Observe the following items. Failure to do so may cause incorrect data-writing through noise to the PLC and result in PLC failure, machine damage or other accident.

- Do not bundle the control line together with or lay it close to the main circuit or power line. As a guideline, lay the control line at least 100mm (3.94") or more away from the main circuit or power line. Noise may cause malfunctions.
- Ground the shield wire or shield of a shielded cable. Do not use common grounding with heavy electrical systems.

- During access (ACCESS LED is lit or flickering) to CompactFlash™ card, do not remove the CompactFlash™ card or power off the CF-ADP. Failure to do so may cause CompactFlash™ card failures or malfunctions.
- If the power is turned OFF while the CompactFlash™ card is being accessed (ACCESS LED is lit or flickering), the buffered data is erased. Also files or CompactFlash™ card itself may be damaged. Do not turn the power OFF while the ACCESS LED is lit or flickering.
- Do not apply excessive pressure to the power supply cable or the power supply connector. Excessive pressure may cause damage or error.

**DISPOSAL PRECAUTIONS** **CAUTION**

- Please contact a certified electronic waste disposal company for the environmentally safe recycling and disposal of your device.

**TRANSPORT AND STORAGE PRECAUTIONS** **CAUTION**

- The product is a precision instrument. During transportation, avoid any impacts. Failure to do so may cause failures in the product. After transportation, verify the operations of the product.

### 3.1 Applicable PLC

Model name	Applicability	Number of connectable units
FX3U Series PLC <sup>*1</sup>	Ver. 2.61 and later	One unit
FX3UC Series PLC <sup>*1</sup>	Ver. 2.61 and later	One unit

The version number can be checked by reading the last three digits of device D8001.

<sup>\*1</sup> An expansion board is required to connect the CF-ADP with the FX3U, FX3UC-32MT-LT(-2) PLCs.

### 3.2 General Specifications

Items other than the following are equivalent to those of the PLC main unit.  
For general specifications, refer to the manual of the PLC main unit.

→ FX3U Series User's Manual - Hardware Edition  
→ FX3UC Series User's Manual - Hardware Edition

Item	Specification
Ambient temperature <sup>*1</sup>	0 to 55°C (32 to 131°F) **** when operating, -25 to 75°C (-13 to 167°F) **** when stored
Dielectric withstand voltage	500V AC for one minute
Insulation resistance	5MΩ or more by 500V DC megger

<sup>\*1</sup> The upper limit of the ambient temperature shall not exceed "20°C" below the upper limit of the CompactFlash™ card operating temperature.

Example : When the upper limit of the CompactFlash™ card operating temperature is 75°C, the upper limit of the ambient temperature is 55°C.

### 3.3 Power Supply Specification

Item	Specification
Power supply voltage	24V DC +20% -15% Ripple (p-p) within 5%
Permitted instantaneous power failure time	Operation continues when the instantaneous power failure is shorter than 1ms.
Current consumption	130mA Connect a 24V DC power supply to the power supply connector.
Interface driving power supply	50mA / 5V DC 5V DC power is supplied internally from the main unit.

### 3.4 Performance Specification

Item	Specification
Data transfer method	Depends on the applied instruction sent from the main unit.
Clock data	Operates based on the clock data in the main unit.
DOS file system	FAT16
The maximum data capacity	2GB
The maximum file size	512MB(Per 1 file)
Data format	CSV format
The number of the maximum files	63 files (When the FIFO function is not used)
FIFO functional file	1 pattern. The file name is automatically assigned.
Data storage directory	Standard file {\FX3U_CF\DATA}. (The directory name is fixed.) FIFO file {\FX3U_CF\DATA\FIFO}. (The directory name is fixed.)
File name type	8.3 file name (The extension is fixed to "CSV".) (Half-width alphanumeric characters and symbols and character strings allowed in the MS-DOS)
Number of I/O occupied points	0 point (This number is not related to the maximum number of input/output points of the PLC.)
Number of connectable units to the main unit	1 unit <sup>*1</sup>

<sup>\*1</sup> The CF-ADP is handled in the same way as communication expansion boards and communication special adapters, and occupies one communication channel.

### 3.5 CF Card ACCESS Switch Specification

Setting item	Description
ON	Access to the CompactFlash™ card enabled
OFF <sup>*1</sup>	Access to the CompactFlash™ card disabled

<sup>\*1</sup> Turn OFF the CF card ACCESS switch, and then confirm that the BUFFER LED and ACCESS LED are completely OFF before removing the CompactFlash™ card or turning OFF the power of the CF-ADP.

### 3.6 CompactFlash™ card Specification

Item	Specification
Operating ambient humidity	5 to 95%RH (no condensation)
Power supply voltage	3.3V 150mA or less
Connector shape	TYPE I
Format form	FAT16 (The CompactFlash™ card shall be formatted in accordance with the FAT16 in advance.)
Data capacity	2GB or less
Connector terminal	Gilding
No. of installable cards	1

### 3.7 Applicable CompactFlash™ cards

The following CompactFlash™ cards are applicable for the CF-ADP.

	Model	Description
CompactFlash™ Card	GT05-MEM-128MC	Flash ROM 128MB
	GT05-MEM-256MC	Flash ROM 256MB
	GT05-MEM-512MC	Flash ROM 512MB
	GT05-MEM-1GC	Flash ROM 1GB
	GT05-MEM-2GC	Flash ROM 2GB

#### Caution

The life of a CompactFlash™ card is expired when data is written to it a specified number of times.

Generally, at the end of the operational life, the CompactFlash™ card has reduced capabilities.

Please use it ensuring sufficient availability.

#### 3.8 Power OFF procedure

Make sure to perform either of the following procedures when turning OFF the power of the CF-ADP. For details, refer to the following manual.

→ FX3U-CF-ADP User's Manual

- Power OFF procedure using the CF card ACCESS switch
  - Set the main unit to the STOP mode, or set the applied instruction for the CF-ADP to the unactuated status.
  - Turn OFF the CF card ACCESS switch, and then confirm that the BUFFER LED and ACCESS LED are completely OFF.
  - Turn OFF the power of the CF-ADP.
- Power OFF procedure using the applied instruction for the CF-ADP
  - Execute the FLCMD instruction to unmount the CompactFlash™ card.
  - Confirm that the FLCMD instruction is completed normally.
  - Turn OFF the power of the CF-ADP.

#### CAUTION

If the power is turned OFF while the CompactFlash™ card is being accessed (ACCESS LED is lit or flickering), the buffered data is erased. Also files or CompactFlash™ card itself may be damaged.  
Do not turn the power OFF while the ACCESS LED is lit or flickering.

This manual confers no industrial property rights or any rights of any other kind, nor does it confer any patent licenses. Mitsubishi Electric Corporation cannot be held responsible for any problems involving industrial property rights which may occur as a result of using the contents noted in this manual.

#### Warranty

Mitsubishi will not be held liable for damage caused by factors found not to be the cause of Mitsubishi; opportunity loss or lost profits caused by faults in the Mitsubishi products; damage, secondary damage, accident compensation caused by special factors unpredictable by Mitsubishi; damages to products other than Mitsubishi products; and to other duties.

### For safe use

- This product has been manufactured as a general-purpose part for general industries, and has not been designed or manufactured to be incorporated in a device or system used in purposes related to human life.
- Before using the product for special purposes such as nuclear power, electric power, aerospace, medicine or passenger movement vehicles, consult with Mitsubishi Electric.
- This product has been manufactured under strict quality control. However when installing the product where major accidents or losses could occur if the product fails, install appropriate backup or failsafe functions in the system.

**MITSUBISHI ELECTRIC CORPORATION**

HEAD OFFICE : TOKYO BUILDING, 2-7-3 MARUNOUCHI, CHIYODA-KU, TOKYO 100-8310, JAPAN  
HIMEJI WORKS : 840, CHIYODA CHO, HIMEJI, JAPAN

**MITSUBISHI** *Changes for the Better*  
 PROGRAMMABLE CONTROLLERS  
**FX3U-CF-ADP**  
**INSTALLATION MANUAL**

Manual Number	JY997D35201
Revision	B
Date	September 2010

This manual describes the part names, dimensions, mounting, and specifications of the product. Before use, read this manual and the manuals of all relevant products fully to acquire proficiency in handling and operating the product. Make sure to learn all the product information, safety information, and precautions. Store this manual in a safe place so that it can be taken out and read whenever necessary. Always forward it to the end user.

Registration: CompactFlash is a trademark of SanDisk Corporation in the United States and other countries. The company and product names described in this manual are registered trademarks or the trademarks of their respective companies.

Effective September 2010  
 Specifications are subject to change without notice.  
 © 2009 Mitsubishi Electric Corporation

**Safety Precaution** (Read these precautions before use.)  
 This manual classifies the safety precautions into two categories:  
 ⚠ DANGER and ⚠ CAUTION.

<b>DANGER</b>	Indicates that incorrect handling may cause hazardous conditions, resulting in death or severe injury.
<b>CAUTION</b>	Indicates that incorrect handling may cause hazardous conditions, resulting in medium or slight personal injury or physical damage.

Depending on the circumstances, procedures indicated by ⚠ CAUTION may also cause severe injury. It is important to follow all precautions for personal safety.

**Associated Manuals**

Manual name	Manual No.	Description
FX3U-CF-ADP User's Manual	JY997D35401 MODEL CODE: 09R720	Describes details of the FX3U-CF-ADP CF card special adapter.
FX3G/FX3U/FX3UC Series Programming Manual - Basic & Applied Instruction Edition	JY997D16601 MODEL CODE: 09R517	Describes PLC programming for basic/applied instructions and devices.
FX3U Series User's Manual - Hardware Edition	JY997D16501 MODEL CODE: 09R516	Explains the FX3U Series PLC specifications for I/O, wiring, installation, and maintenance.
FX3UC Series User's Manual - Hardware Edition	JY997D28701 MODEL CODE: 09R519	Explains the FX3UC Series PLC specifications for I/O, wiring, installation, and maintenance.

**How to obtain manuals**  
 For product manuals or documents, consult with the Mitsubishi Electric dealer from who you purchased your product.

**Certification of UL, cUL standards**  
 FX3U-CF-ADP units comply with the UL standards (UL, cUL).  
 UL, cUL File Number: E95239  
 Regarding the standards that comply with the main unit, please refer to either the FX series product catalog or consult with your nearest Mitsubishi product provider.

**Compliance with EC directive (CE Marking)**  
 This note does not guarantee that an entire mechanical module produced in accordance with the contents of this note will comply with the following standards: Compliance to EMC directive and LVD directive for the entire mechanical module should be checked by the user / manufacturer. For more information please consult with your nearest Mitsubishi product provider.  
 Regarding the standards that comply with the main unit, please refer to either the FX series product catalog or consult with your nearest Mitsubishi product provider.

**Attention**  
 • This product is designed for use in industrial applications.  
**Note**  
 • Manufactured by: Mitsubishi Electric Corporation  
 2-7-3 Marunouchi, Chiyoda-ku, Tokyo, 100-8310 Japan  
 • Manufactured at: Mitsubishi Electric Corporation Himeji Works  
 840 Chiyoda-machi, Himeji, Hyogo, 670-8677 Japan  
 • Authorized Representative in the European Community:  
 Mitsubishi Electric Europe B.V.  
 Gothaer Str. 8, 40880 Ratingen, Germany

**Requirement for Compliance with EMC directive**  
 The following products have shown compliance through direct testing (of the identified standards below) and design analysis (through the creation of a technical construction file) to the European Directive for Electromagnetic Compatibility (2004/108/EC) when used as directed by the appropriate documentation.

Type: Programmable Controller (Open Type Equipment)  
 Models: MELSEC FX3U series manufactured from June 1st, 2009 FX3U-CF-ADP

Standard	Remark
EN61131-2:2007 Programmable controllers - Equipment requirements and tests	Compliance with all relevant aspects of the standard.
EMC	• Radiated Emissions • Conducted Emissions
EMS	• Radiated electromagnetic field • Fast Transient burst • Electrostatic discharge • High-energy surge • Voltage drops and interruptions • Conducted RF • Power frequency magnetic field

**Caution for EC Directive**  
 • Installation in Enclosure  
 Programmable logic controllers are open-type devices that must be installed and used within conductive control cabinets. Please use the programmable logic controller while installed within a conductive shielded control cabinet. Installation within a control cabinet greatly affects the safety of the system and aids in shielding noise from the programmable logic controller.  
 • Control cabinet  
 - The control cabinet must be conductive.  
 - Ground the control cabinet with the thickest possible grounding cable.  
 - To ensure that there is electric contact between the control cabinet and its door, connect the cabinet and its doors with thick wires.  
 - In order to suppress the leakage of radio waves, the control cabinet structure must have minimal openings. Also, wrap the cable holes with a shielding cover or other shielding devices.  
 - The gap between the control cabinet and its door must be as small as possible by attaching EMI gaskets between them.

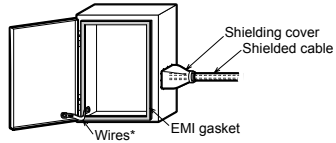

\* These wires are used to improve the conductivity between the door and control cabinet.

**1. Introduction**

The CF card special adapter FX3U-CF-ADP (hereinafter abbreviated as "CF-ADP") stores data to and reads data from the CompactFlash™ card (CF card) in accordance with applied instructions for the CF-ADP sent from the FX3U/FX3UC PLC. Data is stored in CSV format on the CompactFlash™ card. Only one CF-ADP unit can be connected to a single main unit. For system configuration, refer to the following manual.  
 → FX3U-CF-ADP User's Manual

**1.1 Function outline**

- 1) Data can be saved in the CompactFlash™ card in files with the FIFO (first in, first out) function.
- 2) Data can be saved in a specified file stored in the CompactFlash™ card.
- 3) Data can be read from the CompactFlash™ card.

**1.2 Incorporated Items**

Check to ensure the following product and items are included in the package:

Product	Item
FX3U-CF-ADP CF card special adapter	
Accessories	FX2NC-100MPCB Power supply cable (1m (3'3")) x 1 cable Dust proof protection sheet x 1 sheet Installation manual (This manual)

**1.3 External Dimensions and Part Names**

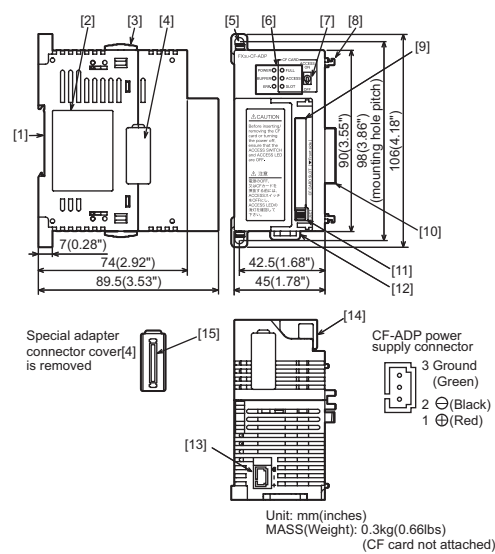

- |   |                                    |
|---|------------------------------------|
| [1] DIN rail mounting groove (DIN rail: DIN46277, 35mm (1.38") width)         | [10] Special adapter connector     |
| [2] Nameplate   | [11] EJECT button                  |
| [3] Special adapter slide hook  | [12] DIN rail mounting hook        |
| [4] Special adapter connector cover   | [13] CF-ADP power supply connector |
| [5] Direct mounting hole (2 holes of φ 4.5 (0.18") (mounting screw: M4 screw) | [14] CF card cover                 |
| [6] Status LEDs   | [15] Special adapter connector     |
| [7] CF card ACCESS switch   |                                    |
| [8] Special adapter fixing hook   |                                    |
| [9] CF card slot  |                                    |

**3.2 General Specifications**

Items other than the following are equivalent to those of the PLC main unit. For general specifications, refer to the manual of the PLC main unit.  
 → FX3U Series User's Manual - Hardware Edition  
 → FX3UC Series User's Manual - Hardware Edition

Item	Specification
Ambient temperature <sup>1</sup>	0 to 55°C (32 to 131°F) **** when operating. -25 to 75°C (-13 to 167°F) **** when stored
Dielectric withstand voltage	500V AC for one minute
Insulation resistance	5MΩ or more by 500V DC megger

\*1 The upper limit of the ambient temperature shall not exceed "20°C" below the upper limit of the CompactFlash™ card operating temperature.  
 Example : When the upper limit of the CompactFlash™ card operating temperature is 75°C, the upper limit of the ambient temperature is 55°C.

**3.3 Power Supply Specification**

Item	Specification
Power supply voltage	24V DC +20% -15% Ripple (p-p) within 5%
Permitted instantaneous power failure time	Operation continues when the instantaneous power failure is shorter than 1ms.
Current consumption	130mA Connect a 24V DC power supply to the power supply connector.
Interface driving power supply	50mA / 5V DC 5V DC power is supplied internally from the main unit.

**3.4 Performance Specification**

Item	Specification
Data transfer method	Depends on the applied instruction sent from the main unit.
Clock data	Operates based on the clock data in the main unit.
DOS file system	FAT16
The maximum data capacity	2GB
The maximum file size	512MB(Per 1 file)
Data format	CSV format
The number of the maximum files	63 files (When the FIFO function is not used)
FIFO functional file	1 pattern. The file name is automatically assigned.
Data storage directory	Standard file √FX3U_CF\DATA. (The directory name is fixed.) FIFO file √FX3U_CF\DATA\FIFO. (The directory name is fixed.)
File name type	8.3 file name (The extension is fixed to "CSV".) (Half-width alphanumeric characters and symbols and character strings allowed in the MS-DOS)
Number of I/O occupied points	0 point (This number is not related to the maximum number of input/output points of the PLC.)
Number of connectable units to the main unit	1 unit <sup>1</sup>

\*1 The CF-ADP is handled in the same way as communication expansion boards and communication special adapters, and occupies one communication channel.

**3.5 CF Card ACCESS Switch Specification**

Setting item	Description
ON	Access to the CompactFlash™ card enabled
OFF <sup>1</sup>	Access to the CompactFlash™ card disabled

\*1 Turn OFF the CF card ACCESS switch, and then confirm that the BUFFER LED and ACCESS LED are completely OFF before removing the CompactFlash™ card or turning OFF the power of the CF-ADP.

**1.4 Power and status LEDs**

LED display	LED color	Status	Description
POWER	Green	OFF	Power is not being supplied from the external power supply (24V DC).
		ON	Power is being supplied from the external power supply (24V DC).
BUFFER	Green	OFF	Data is not stored in the internal buffer.
		ON	Data is stored in the internal buffer.
ERR.	Red	OFF	No errors.
		ON	CF write error, CompactFlash™ card error, etc. has occurred.
FULL	Red	OFF	The CompactFlash™ card has free space.
		Flicker	The free space in the CompactFlash™ card is 20% or less of the full capacity.
		ON	The CompactFlash™ card has no free space. The free space in the CompactFlash™ card is 1% or less of the full capacity.
ACCESS	Green	OFF	CompactFlash™ card not accessed.
		ON	CompactFlash™ card accessed.
SLOT	Green	OFF	The CompactFlash™ card is not inserted, or the slot is in the CompactFlash™ card unmounted status.
		ON	The CompactFlash™ card is inserted, or the slot is in the card mounted status.

**2. Installation**

For installation details, refer to the following manuals.  
 → Refer to the FX3U-CF-ADP User's Manual.

**INSTALLATION PRECAUTIONS** ⚠ **DANGER**

• Make sure to shut down all phases of the power supply externally before installing the CF-ADP.  
 Failure to do so may cause electric shock or damage to the product.

**INSTALLATION PRECAUTIONS** ⚠ **CAUTION**

• Use the product within the generic environment specifications described in PLC main unit manual (Hardware Edition).  
 Never use the product in areas with excessive dust, oily smoke, conductive dusts, corrosive gas (salt air, Cl<sub>2</sub>, H<sub>2</sub>S, SO<sub>2</sub>, or NO<sub>2</sub>), flammable gas, vibration or impacts, or expose it to high temperature, condensation, or rain and wind.  
 If the product is used in such conditions, electric shock, fire, malfunctions, deterioration or damage may occur.  
 • Do not touch the conductive parts of the product directly.  
 Doing so may cause device failures or malfunctions.  
 • Install the product securely using a DIN rail or mounting screws.  
 • Install the product on a flat surface.  
 If the mounting surface is rough, undue force will be applied to the PC board, thereby causing nonconformities.  
 • When drilling screw holes or wiring, make sure that cutting and wiring debris do not enter the ventilation slits.  
 Failure to do so may cause fire, equipment failures or malfunctions.  
 • Be sure to remove the dust proof sheet from the PLC's ventilation port when installation work is completed.  
 Failure to do so may cause fire, equipment failures or malfunctions.  
 • Connect the CF-ADP securely to special adapter connector.  
 Loose connections may cause malfunctions.  
 • Connect the power connector of the power supply cable securely to the CF-ADP power supply connector.  
 Loose connections may cause malfunctions.  
 • When inserting a CompactFlash™ card into the CF-ADP, push it into the CF card slot until the EJECT button pops out.  
 Loose connections may cause malfunctions.

**INSTALLATION PRECAUTIONS** ⚠ **CAUTION**

• Before inserting/removing a CompactFlash™ card into/from the CF-ADP, set the CF card ACCESS switch to OFF and confirm that the BUFFER LED and ACCESS LED are both OFF.  
 Failure to do so may corrupt data within the CompactFlash™ card.  
 • When removing a CompactFlash™ card from the CF-ADP, make sure to support the CompactFlash™ card by hand, as it may pop out.  
 Failure to do so may cause the CompactFlash™ card to fall from the CF-ADP and break.

**2.1 Connection with PLC**  
 Only one CF-ADP can be connected to the left side of a PLC main unit or special adapter.  
 An expansion board is necessary to connect the CF-ADP with the FX3U, FX3UC-32MT-LT PLC.  
 For details, refer to the respective PLC manual.  
 → FX3U Series User's Manual - Hardware Edition  
 → FX3UC Series User's Manual - Hardware Edition

**2.2 Mounting**  
 The product is mounted by the following method.  
 • DIN rail mounting  
 • Direct mounting (mounting screw: M4 screw)  
 For details, refer to the respective PLC manual.  
 → FX3U Series User's Manual - Hardware Edition  
 → FX3UC Series User's Manual - Hardware Edition

**2.3 Inserting and Removal Procedures**

**2.3.1 Inserting the CompactFlash™ card**  
 The CompactFlash™ card can be inserted when the CF-ADP is power off.  
 When the power supply of CF-ADP is ON and it inserts the CompactFlash™ card, make sure to perform the following procedures.  
 1) Set the CF card ACCESS switch to OFF (A in the figure on the right) in the CF-ADP. Confirm that the POWER LED is lit.

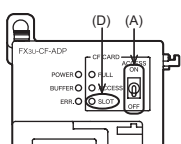

2) Open the CF card cover.  
 Insert the CompactFlash™ card into the CF card slot with the front side (side B in the figure on the right) facing the right side of the CF-ADP until the EJECT button (side C in the figure on the right) pops out.

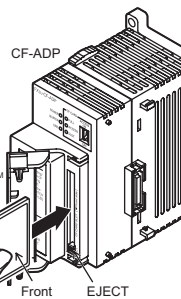

3) Confirm that the CF card ACCESS LED is lit or flickers and turns OFF, and then the SLOT LED (D in the figure on the right) turns ON.

4) Close the CF card cover.  
 Set the CF card ACCESS switch to ON.

**2.3.2 Removing the CompactFlash™ card**  
 The CompactFlash™ card can be removed when the CF-ADP is power off.  
 When the power supply of CF-ADP is ON and it removes the CompactFlash™ card, make sure to perform the following procedures.  
 1) Set the CF card ACCESS switch of the CF-ADP to OFF (A in the figure on the right), and make sure that the CF card ACCESS LED and BUFFER LED (B in the figure on the right) both turn off. (When the CF card ACCESS LED turns off, the CompactFlash™ card can be removed even when the CF-ADP is powering on.)

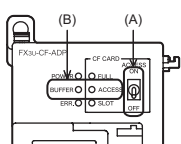

**CAUTION**  
 When the CF card ACCESS LED is lit or flickering, do not removing the CompactFlash™ card or power off the CF-ADP.  
 Doing so may cause data corruption or malfunction.

**3. Specification**  
 For details on specifications, refer to the following manual.  
 → FX3U-CF-ADP User's Manual

**DESIGN PRECAUTIONS** ⚠ **DANGER**

• Make sure to include the following safety circuits outside the PLC to ensure safe system operation even during external power supply problems or PLC failure. Otherwise, malfunctions may cause serious accidents.  
 1) Above all, the following components should be included: an emergency stop circuit, a protection circuit, an interlock circuit for opposite movements (such as normal vs. reverse rotation), and an interlock circuit (to prevent damage to the equipment at the upper and lower positioning limits).  
 2) Note that when the PLC main unit detects an error during self diagnosis, such as a watchdog timer error, all outputs are turned off. Also, when an error that cannot be detected by the PLC main unit occurs in an input/output control block, output control may be disabled.  
 External circuits and mechanisms should be designed to ensure safe machinery operation in such cases.

**DESIGN PRECAUTIONS** ⚠ **CAUTION**

• Observe the following items. Failure to do so may cause incorrect data-writing through noise to the PLC and result in PLC failure, machine damage or other accident.  
 1) Do not bundle the control line together with or lay it close to the main circuit or power line. As a guideline, lay the control line at least 100mm (3.94") or more away from the main circuit or power line.  
 Noise may cause malfunctions.  
 2) Ground the shield wire or shield of a shielded cable. Do not use common grounding with heavy electrical systems.  
 • During access (ACCESS LED is lit or flickering) to CompactFlash™ card, do not remove the CompactFlash™ card or power off the CF-ADP.  
 Failure to do so may cause CompactFlash™ card failures or malfunctions.  
 • If the power is turned OFF while the CompactFlash™ card is being accessed (ACCESS LED is lit or flickering), the buffered data is erased. Also files or CompactFlash™ card itself may be damaged. Do not turn the power OFF while the ACCESS LED is lit or flickering.  
 • Do not apply excessive pressure to the power supply cable or the power supply connector.  
 Excessive pressure may cause damage or error.

**DISPOSAL PRECAUTIONS** ⚠ **CAUTION**

• Please contact a certified electronic waste disposal company for the environmentally safe recycling and disposal of your device.

**TRANSPORT AND STORAGE PRECAUTIONS** ⚠ **CAUTION**

• The product is a precision instrument. During transportation, avoid any impacts.  
 Failure to do so may cause failures in the product. After transportation, verify the operations of the product.

**3.1 Applicable PLC**

Model name	Applicability	Number of connectable units
FX3U Series PLC <sup>1</sup>	Ver. 2.61 and later	One unit
FX3UC Series PLC <sup>1</sup>	Ver. 2.61 and later	One unit

The version number can be checked by reading the last three digits of device D8001.

\*1 An expansion board is required to connect the CF-ADP with the FX3U, FX3UC-32MT-LT(-2) PLCs.