

FX_{2N}

FX2N-16CCL-M CC-Link SYSTEM MASTER BLOCK

HARDWARE MANUAL

JY992D93201D

This manual contains text, diagrams and explanations which will guide the reader in the correct installation and operation of the FX_{2N}-16CCL-M CC-Link SYSTEM MASTER BLOCK. It should be read and understood before attempting to install or use the unit. Further information can be found in the FX series PLC hardware manuals.

Note's on the symbology used in this manual

At various times through out this manual certain symbols will be used to highlight points of information which are intended to ensure the user's personal safety and protect the integrity of the equipment. Whenever any of the following symbols are encountered, its associated note must be read and understood. Each of the symbols used will now be listed with a brief description of its meaning.

Hardware warnings

- 1) Indicates that the identified danger WILL cause physical and property damage.
- 2) Indicates that the identified danger could POSSIBLY cause physical and property damage.

1. INTRODUCTION

1.1 Associated Manuals

| Manual name | Manual number | Description |
|--|--------------------------------------|---|
| ★FX _{2N} -16CCL-M User's Manual | JY992D93101 (sent separately) | Describes programming and handling of the CC-Link master block FX _{2N} -16CCL-M. |
| ★FX _{1S} /FX _{1N} /FX _{2N} /FX _{2NC} Programming Manual II | JY992D88101 (sent separately) | Explains the instructions available to the FX _{1S} /FX _{1N} /FX _{2N} /FX _{2NC} Series PLC. |
| ★FX _{3G} /FX _{3U} /FX _{3UC} Programming Manual | JY997D16601 (sent separately) | Explains the instructions available to the FX _{3G} /FX _{3U} /FX _{3UC} Series PLC. |
| ☆FX _{1N} Hardware Manual | JY992D89301 (packed with product) | Describes hardware specifications, wiring and mounting of the FX _{1N} Series PLC. |
| ☆FX _{2N} Hardware Manual | JY992D66301 (packed with product) | Describes the contents related to the hardware such as specifications, wiring and mounting of the FX _{2N} Series PLC. |
| ☆FX _{3G} Hardware Manual | JY992D33401 (packed with product) | Describes the name of each part and harding of the FX _{3G} Series PLC. |
| ☆FX _{3G} Series User's Manual - Hardware Edition | JY997D31301 (sent separately) | Describes the contents related to the hardware such as specifications, wiring and mounting of the FX _{3G} Series PLC. |
| ☆FX _{3U} Hardware Manual | JY997D18801 (packed with product) | Describes the name of each part and harding of the FX _{3U} Series PLC. |
| ☆FX _{3U} Series User's Manual - Hardware Edition | JY997D16501 (sent separately) | Describes the hardware specifications, wiring and mounting of the FX _{3U} Series PLC. |
| ☆FX _{2NC} (DSS/S) Hardware Manual | JY992D76401 (packed with product) | Describes the hardware specifications, wiring and mounting of the FX _{2NC} Series PLC. |
| ☆FX _{2NC} (D/UL) Hardware Manual | JY997D87201 (packed with product) | Describes the contents related to the hardware such as specifications, wiring and mounting of the FX _{2NC} Series PLC. |
| ☆FX _{3U} (D,DSS) Hardware Manual | JY992D28601 (packed with product) | Describes the name of each part and harding of the FX _{3U} Series PLC. |
| ☆FX _{3UC} Series User's Manual - Hardware Edition | JY997D28701 (sent separately) | Describes the hardware specifications, wiring and mounting of the FX _{3UC} Series PLC. |
| ☆FX _{2N} -32CCL User's Manual | JY992D71801 (packed with product) | Describes programming and handling of the CC-Link interface block FX _{2N} -32CCL. |

★: Indispensable manual

☆: Manual required depending on equipment used

1.2 Overview

The CC-Link master block FX2N-16CCL-M is a special extension block which assigns an FX Series PLC as the master station of the CC-Link system.

- Remote I/O stations and remote device stations can be connected to the master station (FX Series PLC).
 Master station : Station which controls the data link system
 Remote I/O station : Remote station which handles only bit information
 Remote device station : Remote station which handles both bit information and word information
- By using the CC-Link interface block FX2N-32CCL, two or more FX Series PLCs can be connected as remote device stations to configure a simple distributed system.

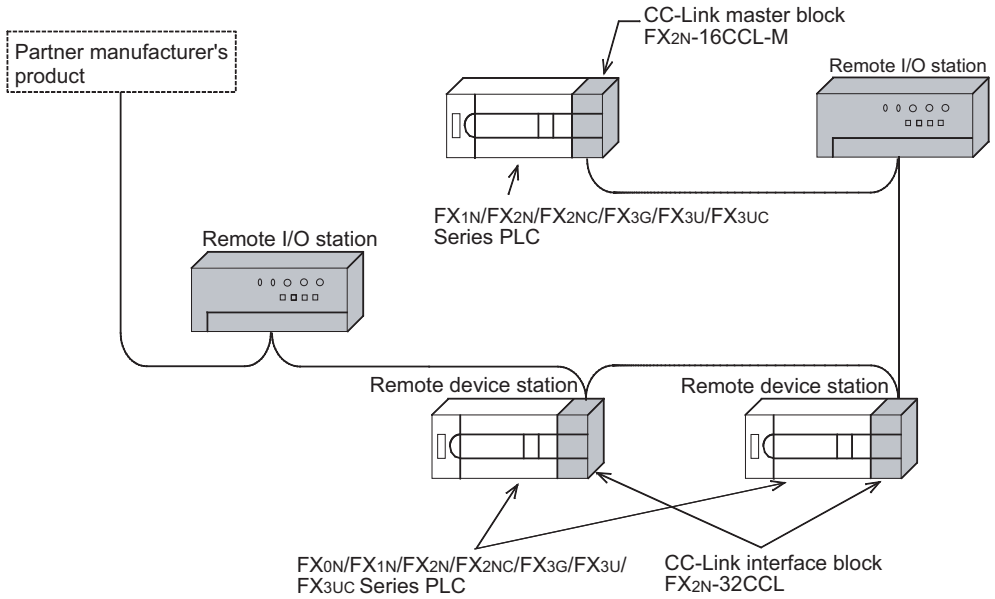

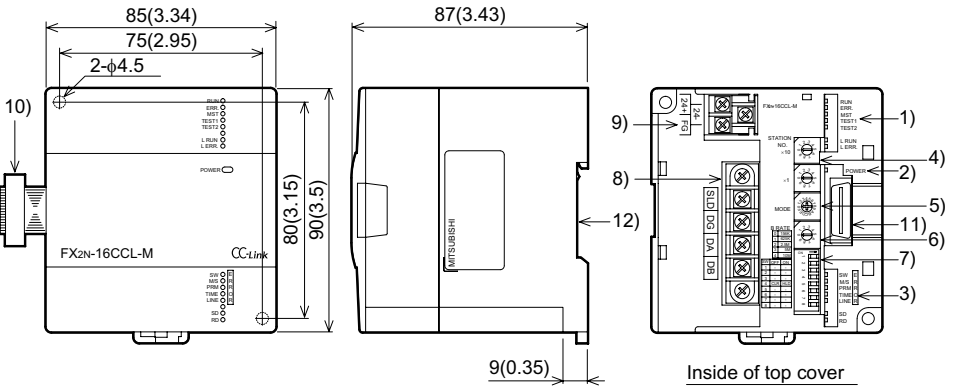

1.3 Dimensions and Setting

Dimensions: mm (inches) MASS (Weight): 0.4 kg (0.88 lbs)

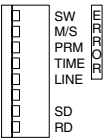
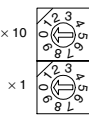

| Number | Name | Description | | | |
|--------|------------------|-------------|--|------------------------|---|
| | | LED name | Description | LED status | |
| 1) | LED indicators 1 | RUN | ON : Module is normal. OFF: Watchdog time error has occurred. | ON | OFF |
| | | ERR. | Indicates the communication status with the stations set in the parameters. ON : Communication error has occurred in all stations. Flashing : Communication error has occurred in some stations. | OFF | ON or flashing |
| | | MST | ON : Set as the master station | ON | OFF |
| | | TEST1 | Test result indication | OFF except during test | |
| | | TEST2 | Test result indication | | |
| | | L RUN | ON : Data link is being executed (host station). | ON | OFF |
| | | L ERR. | ON : Communication error has occurred (host station). Flashing : The settings of the switches 4) to 7) were changed while the power was ON. | OFF | ON or flashing |
| | | 2) | Power indicator | POWER | ON : 24V DC is supplied from the outside. |

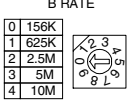
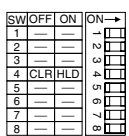
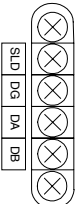
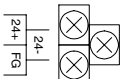
| Number | Name | Description | | | | | | | | | | | | | | | | | | | | | | | | | | | | | | | | | | |
|---|--|--|---|---|--|--------|---------------------|---------------|--|----------|-------------------------------|------------|--|------------|----|----------|--|------------|-------------|-------------------------|---|-------------|-------------------------|--------|---|---------------------------------|----|---------------|-------------------------|----|---------------------------------|--|--------|------------|--|--------|
| 3) | LED indicators 2  | <table border="1"> <tr> <td rowspan="5" style="writing-mode: vertical-rl; transform: rotate(180deg);">ERROR</td> <td>SW</td> <td>ON : Switch setting error has occurred.</td> <td>OFF</td> <td>ON</td> </tr> <tr> <td>M/S</td> <td>ON : The master station is already present in the same line.</td> <td>OFF</td> <td>ON</td> </tr> <tr> <td>PRM</td> <td>ON : Parameter setting error has occurred.</td> <td>OFF</td> <td>ON</td> </tr> <tr> <td>TIME</td> <td>ON : Data link watchdog timer errors has occurred (error in all stations).</td> <td>OFF</td> <td>ON</td> </tr> <tr> <td>LINE</td> <td>ON : The cable is broken or the transmission route has been affected by noise, etc.</td> <td>OFF</td> <td>ON</td> </tr> <tr> <td></td> <td>SD</td> <td>ON : Data is being transmitted.</td> <td>ON</td> <td>OFF</td> </tr> <tr> <td></td> <td>RD</td> <td>ON : Data is being received. *1</td> <td>ON</td> <td>OFF</td> </tr> </table> | ERROR | SW | ON : Switch setting error has occurred. | OFF | ON | M/S | ON : The master station is already present in the same line. | OFF | ON | PRM | ON : Parameter setting error has occurred. | OFF | ON | TIME | ON : Data link watchdog timer errors has occurred (error in all stations). | OFF | ON | LINE | ON : The cable is broken or the transmission route has been affected by noise, etc. | OFF | ON | | SD | ON : Data is being transmitted. | ON | OFF | | RD | ON : Data is being received. *1 | ON | OFF | | | |
| | | ERROR | | SW | ON : Switch setting error has occurred. | OFF | ON | | | | | | | | | | | | | | | | | | | | | | | | | | | | | |
| | | | | M/S | ON : The master station is already present in the same line. | OFF | ON | | | | | | | | | | | | | | | | | | | | | | | | | | | | | |
| | | | | PRM | ON : Parameter setting error has occurred. | OFF | ON | | | | | | | | | | | | | | | | | | | | | | | | | | | | | |
| | | | | TIME | ON : Data link watchdog timer errors has occurred (error in all stations). | OFF | ON | | | | | | | | | | | | | | | | | | | | | | | | | | | | | |
| | | | LINE | ON : The cable is broken or the transmission route has been affected by noise, etc. | OFF | ON | | | | | | | | | | | | | | | | | | | | | | | | | | | | | | |
| | | | SD | ON : Data is being transmitted. | ON | OFF | | | | | | | | | | | | | | | | | | | | | | | | | | | | | | |
| | | | RD | ON : Data is being received. *1 | ON | OFF | | | | | | | | | | | | | | | | | | | | | | | | | | | | | | |
| 4) | Station number setting switch STATION NO.  | Sets the station number of the module. (Default setting at shipment: 00) <Setting range> 00 (because the FX2N-16CCL-M is dedicated to the master station) If "65" or larger number is set, the "SW" and "L ERR." LED indicators turn ON. | | | | | | | | | | | | | | | | | | | | | | | | | | | | | | | | | | |
| | | <table border="1"> <tr> <td colspan="3">Sets the operation status of the module. (Default setting at shipment: 0)</td> </tr> <tr> <th>Number</th> <th>Name</th> <th>Description</th> </tr> <tr> <td>0</td> <td>Online</td> <td>Sets connection to data link.</td> </tr> <tr> <td>1</td> <td>(Unusable)</td> <td>—</td> </tr> <tr> <td>2</td> <td>Offline</td> <td>Sets disconnection from data link.</td> </tr> <tr> <td>3</td> <td>Line test 1</td> <td>Refer to USER'S MANUAL.</td> </tr> <tr> <td>4</td> <td>Line test 2</td> <td>Refer to USER'S MANUAL.</td> </tr> <tr> <td>5</td> <td>Parameter verification test</td> <td>Refer to USER'S MANUAL.</td> </tr> <tr> <td>6</td> <td>Hardware test</td> <td>Refer to USER'S MANUAL.</td> </tr> <tr> <td>7</td> <td>(Unusable)</td> <td>Setting error (The SW LED indicator turns ON.)</td> </tr> <tr> <td>8 to A</td> <td>(Unusable)</td> <td>Cannot be set because it is already used inside.</td> </tr> <tr> <td>B to F</td> <td>(Unusable)</td> <td>Setting error (The SW LED indicator turns ON.)</td> </tr> </table> | Sets the operation status of the module. (Default setting at shipment: 0) | | | Number | Name | Description | 0 | Online | Sets connection to data link. | 1 | (Unusable) | — | 2 | Offline | Sets disconnection from data link. | 3 | Line test 1 | Refer to USER'S MANUAL. | 4 | Line test 2 | Refer to USER'S MANUAL. | 5 | Parameter verification test | Refer to USER'S MANUAL. | 6 | Hardware test | Refer to USER'S MANUAL. | 7 | (Unusable) | Setting error (The SW LED indicator turns ON.) | 8 to A | (Unusable) | Cannot be set because it is already used inside. | B to F |
| Sets the operation status of the module. (Default setting at shipment: 0) | | | | | | | | | | | | | | | | | | | | | | | | | | | | | | | | | | | | |
| Number | Name | Description | | | | | | | | | | | | | | | | | | | | | | | | | | | | | | | | | | |
| 0 | Online | Sets connection to data link. | | | | | | | | | | | | | | | | | | | | | | | | | | | | | | | | | | |
| 1 | (Unusable) | — | | | | | | | | | | | | | | | | | | | | | | | | | | | | | | | | | | |
| 2 | Offline | Sets disconnection from data link. | | | | | | | | | | | | | | | | | | | | | | | | | | | | | | | | | | |
| 3 | Line test 1 | Refer to USER'S MANUAL. | | | | | | | | | | | | | | | | | | | | | | | | | | | | | | | | | | |
| 4 | Line test 2 | Refer to USER'S MANUAL. | | | | | | | | | | | | | | | | | | | | | | | | | | | | | | | | | | |
| 5 | Parameter verification test | Refer to USER'S MANUAL. | | | | | | | | | | | | | | | | | | | | | | | | | | | | | | | | | | |
| 6 | Hardware test | Refer to USER'S MANUAL. | | | | | | | | | | | | | | | | | | | | | | | | | | | | | | | | | | |
| 7 | (Unusable) | Setting error (The SW LED indicator turns ON.) | | | | | | | | | | | | | | | | | | | | | | | | | | | | | | | | | | |
| 8 to A | (Unusable) | Cannot be set because it is already used inside. | | | | | | | | | | | | | | | | | | | | | | | | | | | | | | | | | | |
| B to F | (Unusable) | Setting error (The SW LED indicator turns ON.) | | | | | | | | | | | | | | | | | | | | | | | | | | | | | | | | | | |
| 5) | Mode setting switch MODE  | <table border="1"> <tr> <td colspan="3">Sets the transmission speed of the module. (Default setting at shipment: 0)</td> </tr> <tr> <th>Number</th> <th colspan="2">Setting contents</th> </tr> <tr> <td>0</td> <td colspan="2">156 kbps</td> </tr> <tr> <td>1</td> <td colspan="2">625 kbps</td> </tr> <tr> <td>2</td> <td colspan="2">2.5 Mbps</td> </tr> <tr> <td>3</td> <td colspan="2">5 Mbps</td> </tr> <tr> <td>4</td> <td colspan="2">10 Mbps</td> </tr> <tr> <td>5 to 9</td> <td colspan="2">Setting error (The SW and L ERR. LED indicators turn ON.)</td> </tr> </table> | Sets the transmission speed of the module. (Default setting at shipment: 0) | | | Number | Setting contents | | 0 | 156 kbps | | 1 | 625 kbps | | 2 | 2.5 Mbps | | 3 | 5 Mbps | | 4 | 10 Mbps | | 5 to 9 | Setting error (The SW and L ERR. LED indicators turn ON.) | | | | | | | | | | | |
| | | Sets the transmission speed of the module. (Default setting at shipment: 0) | | | | | | | | | | | | | | | | | | | | | | | | | | | | | | | | | | |
| | | Number | Setting contents | | | | | | | | | | | | | | | | | | | | | | | | | | | | | | | | | |
| | | 0 | 156 kbps | | | | | | | | | | | | | | | | | | | | | | | | | | | | | | | | | |
| | | 1 | 625 kbps | | | | | | | | | | | | | | | | | | | | | | | | | | | | | | | | | |
| | | 2 | 2.5 Mbps | | | | | | | | | | | | | | | | | | | | | | | | | | | | | | | | | |
| | | 3 | 5 Mbps | | | | | | | | | | | | | | | | | | | | | | | | | | | | | | | | | |
| 4 | 10 Mbps | | | | | | | | | | | | | | | | | | | | | | | | | | | | | | | | | | | |
| 5 to 9 | Setting error (The SW and L ERR. LED indicators turn ON.) | | | | | | | | | | | | | | | | | | | | | | | | | | | | | | | | | | | |
| 6) | Transmission speed setting switch B RATE  | <table border="1"> <tr> <td>0</td> <td>156K</td> </tr> <tr> <td>1</td> <td>625K</td> </tr> <tr> <td>2</td> <td>2.5M</td> </tr> <tr> <td>3</td> <td>5M</td> </tr> <tr> <td>4</td> <td>10M</td> </tr> </table> | 0 | 156K | 1 | 625K | 2 | 2.5M | 3 | 5M | 4 | 10M | | | | | | | | | | | | | | | | | | | | | | | | |
| | | 0 | 156K | | | | | | | | | | | | | | | | | | | | | | | | | | | | | | | | | |
| | | 1 | 625K | | | | | | | | | | | | | | | | | | | | | | | | | | | | | | | | | |
| | | 2 | 2.5M | | | | | | | | | | | | | | | | | | | | | | | | | | | | | | | | | |
| | | 3 | 5M | | | | | | | | | | | | | | | | | | | | | | | | | | | | | | | | | |
| | | 4 | 10M | | | | | | | | | | | | | | | | | | | | | | | | | | | | | | | | | |
| 7) | Condition setting switch  | <table border="1"> <tr> <td colspan="3">Sets the operation condition. (Default setting at shipment: All OFF)</td> </tr> <tr> <th rowspan="2">Number</th> <th rowspan="2">Setting description</th> <th colspan="2">Switch status</th> </tr> <tr> <th>ON</th> <th>OFF</th> </tr> <tr> <td>SW1 to SW3</td> <td>(Unusable)</td> <td colspan="2">Always OFF</td> </tr> <tr> <td>SW4</td> <td>Input data status in data link faulty station</td> <td>Keep (HLD)</td> <td>Clear (CLR)</td> </tr> <tr> <td>SW5 to SW8</td> <td>(Unusable)</td> <td colspan="2">Always OFF</td> </tr> </table> | Sets the operation condition. (Default setting at shipment: All OFF) | | | Number | Setting description | Switch status | | ON | OFF | SW1 to SW3 | (Unusable) | Always OFF | | SW4 | Input data status in data link faulty station | Keep (HLD) | Clear (CLR) | SW5 to SW8 | (Unusable) | Always OFF | | | | | | | | | | | | | | |
| | | Sets the operation condition. (Default setting at shipment: All OFF) | | | | | | | | | | | | | | | | | | | | | | | | | | | | | | | | | | |
| | | Number | Setting description | Switch status | | | | | | | | | | | | | | | | | | | | | | | | | | | | | | | | |
| | | | | ON | OFF | | | | | | | | | | | | | | | | | | | | | | | | | | | | | | | |
| | | SW1 to SW3 | (Unusable) | Always OFF | | | | | | | | | | | | | | | | | | | | | | | | | | | | | | | | |
| SW4 | Input data status in data link faulty station | Keep (HLD) | Clear (CLR) | | | | | | | | | | | | | | | | | | | | | | | | | | | | | | | | | |
| SW5 to SW8 | (Unusable) | Always OFF | | | | | | | | | | | | | | | | | | | | | | | | | | | | | | | | | | |
| 8) | Terminal block  | Connects dedicated CC-Link cables to enable data link. For the connection method, refer to Section 2.3. The terminals SLD and FG are connected inside. M3.5 Screw | | | | | | | | | | | | | | | | | | | | | | | | | | | | | | | | | | |
| | | Connects the power supply to operate the master block. M3 Screw | | | | | | | | | | | | | | | | | | | | | | | | | | | | | | | | | | |
| 9) | Terminal block  | Connects the power supply to operate the master block. M3 Screw | | | | | | | | | | | | | | | | | | | | | | | | | | | | | | | | | | |
| 10) | Extension cable | Connects the PLC. | | | | | | | | | | | | | | | | | | | | | | | | | | | | | | | | | | |
| 11) | Next step extension connector | Connects extension equipment. | | | | | | | | | | | | | | | | | | | | | | | | | | | | | | | | | | |
| 12) | DIN rail mounting groove | DIN46277: DIN rail mounting groove of 35 mm (1.38") in width | | | | | | | | | | | | | | | | | | | | | | | | | | | | | | | | | | |

*1 The [RD] LED is darker as the transmission speed is faster and as the number of connected stations is smaller.

2. Installation and wiring



INSTALLATION PRECAUTIONS

- Use the module in the environment described in the USER'S MANUAL General Specification. Do not use the PLC in places with dust, soot, conductive dust, corrosive gas or combustible gas, places exposed to high temperature, condensation, wind or rain or places that experience vibration or impact. Using the module outside the range of the general specification may result in electrical shock, fire, malfunctions, or damage to the PLC.
- When drilling screw holes or performing wiring, make sure that cutting and wiring debris or other foreign matter do not enter the ventilation slits of the module. Such matter may cause fire, failure or malfunction.
- When the installation work is completed, remove the dust protection sheet from the ventilation slits of the PLC. If the sheet remains attached, it may cause fire, failure or malfunction.
- Securely connect extension cables to their specified connectors. Poor contact may cause malfunction.



WIRING PRECAUTIONS

- Before beginning any installation or wiring work, make sure all phases of the power supply have been shut off. Failing to shut off the power supply may cause electrical shock or damage to the module.
- Following installation or wiring work, when turning on the power supply and operating the PLC, make sure that the terminal cover provided as an accessory has been attached to the module. Failing to attach the cover may cause electrical shock.
- For the CC-Link system, use dedicated cables specified by the manufacturer. The performance of the CC-Link system cannot be guaranteed with any cable other than dedicated ones specified by the manufacturer. For the maximum total extension length and the cable length between stations, observe the specifications described in USER'S MANUAL. With wiring outside the specification range, normal data transfer cannot be guaranteed.
- Make sure to fix communication cables and power cables connected to the module by placing them in a duct or clamping them. Cables not placed in a duct or left unclamped may hang or shift, allowing them to be pulled accidentally, which may result in malfunction or damage to the module and the cables.
- When disconnecting a communication/power cable connected to the module, do not hold the cable area. For a cable with a connector, hold the connector attached to the cable. For a cable connected to a terminal block, loosen screws of the terminal block before disconnecting the cable. If a cable is pulled while it is connected to a module, the module may malfunction or the module and the cable may be damaged.



WIRING PRECAUTIONS

- Use a grounding resistor of 100Ω or less with a wire of 2 mm² or more to ground the grounding terminal in the PLC main units. However, never perform common grounding with a high voltage system.

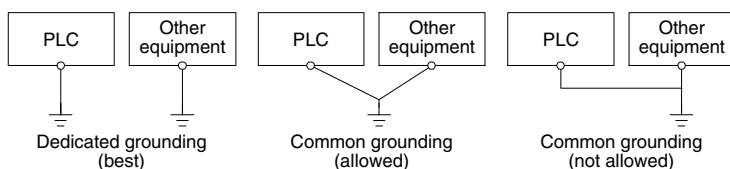

- Do not bundle control cables and communication cables with the main circuit and power cables. Keep control cables and communication cables at least 100 mm away from the main circuit and power cables. Otherwise, electric noise may cause a malfunction.

2.1 Installation

Install the FX2N-16CCL-M on the right side of the FX1N/FX2N/FX2NC/FX3G/FX3U/FX3UC Series main unit, extension unit or another extension block. (For the FX2NC Series, the FX2NC-CNV-IF is required. For the FX3UC Series, the FX2NC-CNV-IF or FX3UC-1PS-5V is required.)

The FX2N-16CCL-M can be installed using a DIN rail (DIN 46277, width: 35 mm (1.38 in.)) or directly with M4 (0.16 in.) screws.

In the case of direct installation, provide a space of 1 to 2 mm (0.04 to 0.08 in.) between the units.

2.2 Dedicated CC-Link Cables

Use dedicated CC-Link cables in the CC-Link system.

If any other cable is used, the performance of the CC-Link system cannot be guaranteed.

2.3 Module Wiring with Dedicated CC-Link Cables

This section describes the connection method of dedicated CC-Link cables.

- The cables can be connected regardless of the station number.
- Make sure to connect a terminal resistor (offered as an accessory to the module) between the terminals DA and DB in the modules at both ends of the CC-Link system.
- In the CC-Link system, the terminal resistor required varies depending on the cable used.
 - When a dedicated CC-Link cable is used: 110 Ω, 1/2 W (brown, brown and brown)
 - When a dedicated high-performance CC-Link cable is used: 130 Ω, 1/2 W (brown, orange and brown)
- The master module can be connected at either end of the system.
- Star configuration is not allowed.
- The figure below shows the connection method.

| Item | Specification |
|---|---|
| Synchronous method | Frame synchronous method |
| Encoding method | NRZI method |
| Transmission path type | Bus (RS-485) |
| Transmission format | In conformance to HDLC Standard |
| Error control method | CRC($X^{16}+X^{12}+X^5+1$) |
| Connection cable | Dedicated CC-Link cable/Dedicated high-performance CC-Link cable *1 |
| RAS function | <ul style="list-style-type: none"> Automatic return function Slave station cutoff function Error detection by link special relay/register |
| Number of times of parameter registration to EEPROM | Approximately 10,000 times |
| Connectable PLC | FX1N, FX2N (V 2.20 or later), FX3U, FX2NC (V 2.20 or later) *2, FX3G, FX3UC *3 Series PLC |
| Number of occupied I/O points | <ul style="list-style-type: none"> 8 I/O points of FX Series PLC (8 points in total. The ratio between inputs and outputs is arbitrary.) When remote I/O station is connected, 32 points per station are occupied. |
| Communication with PLC | By FROM and TO instructions or direct specification of buffer memory (FX3U/FX3UC) via the buffer memory |
| Note | <ul style="list-style-type: none"> Scan method: Asynchronous mode Automatic refresh: Not provided Local station function: Not provided Standby master station function: Not provided Intelligent device station connection function: Not provided FX2N-32ASI-M AS-i master block: Cannot be connected concurrently. |
| Operation indication | <p>POWER : Lit while 24V DC is supplied from outside.</p> <p>L RUN : Lit while communication is normal.</p> <p>L ERR : Lit when communication error has occurred.</p> <p>SD : Lit while data is being transmitted.</p> <p>RD : Lit while data is being received. *4</p> |
| Accessories | <p>Terminal resistor</p> <ul style="list-style-type: none"> For standard cable: 110 Ω, 1/2 W (color cable: brown, brown and brown), 2 cables For high performance cable: 130 Ω, 1/2 W (color cable: brown, orange and brown), 2 cables <p>Special block number label</p> |
| MASS (Weight) | 0.4 kg (0.88 lbs) |

*1 Dedicated CC-Link cables and dedicated high-performance CC-Link cables cannot be used at the same time.

Attach a terminal resistor in accordance with the cable type.

*2 When an FX2NC Series PLC is connected, the interface FX2NC-CNV-IF is required.

*3 When an FX3UC Series PLC is connected, the interface FX2NC-CNV-IF or FX3UC-1PS-5V is required.

*4 The [RD] LED is darker as the transmission speed is faster and as the number of connected stations is smaller.

This manual confers no industrial property rights or any rights of any other kind, nor does it confer any patent licenses. Mitsubishi Electric Corporation cannot be held responsible for any problems involving industrial property rights which may occur as a result of using the contents noted in this manual.

Warranty

Mitsubishi will not be held liable for damage caused by factors found not to be the cause of Mitsubishi; opportunity loss or lost profits caused by faults in the Mitsubishi products; damage, secondary damage, accident compensation caused by special factors unpredictable by Mitsubishi; damages to products other than Mitsubishi products; and to other duties.

For safe use

- This product has been manufactured as a general-purpose part for general industries, and has not been designed or manufactured to be incorporated in a device or system used in purposes related to human life.
- Before using the product for special purposes such as nuclear power, electric power, aerospace, medicine or passenger movement vehicles, consult with Mitsubishi Electric.
- This product has been manufactured under strict quality control. However when installing the product where major accidents or losses could occur if the product fails, install appropriate backup or failsafe functions in the system.

Manual number : JY992D93201

Manual revision : D

Date : JUN. 2010

 **MITSUBISHI ELECTRIC CORPORATION**

HEAD OFFICE : TOKYO BUILDING, 2-7-3 MARUNOUCHI, CHIYODA-KU, TOKYO 100-8310, JAPAN
HIMEJI WORKS : 840, CHIYODA CHO, HIMEJI, JAPAN

JY992D93201D

Effective JUN. 2010

Specifications are subject to change without notice

FX2N-16CCL-M CC-Link SYSTEM MASTER BLOCK

HARDWARE MANUAL

JY992D93201D

This manual contains text, diagrams and explanations which will guide the reader in the correct installation and operation of the FX2N-16CCL-M CC-Link SYSTEM MASTER BLOCK. It should be read and understood before attempting to install or use the unit. Further information can be found in the FX series PLC hardware manuals.

Note's on the symbology used in this manual

At various times through out this manual certain symbols will be used to highlight points of information which are intended to ensure the user's personal safety and protect the integrity of the equipment. Whenever any of the following symbols are encountered, its associated note must be read and understood. Each of the symbols used will now be listed with a brief description of its meaning.

Hardware warnings

- 1) Indicates that the identified danger WILL cause physical and property damage.
- 2) Indicates that the identified danger could POSSIBLY cause physical and property damage.

1. INTRODUCTION

1.1 Associated Manuals

| Manual name | Manual number | Description |
|--|-----------------------------------|---|
| ★FX2N-16CCL-M User's Manual | JY992D93101 (sent separately) | Describes programming and handling of the CC-Link master block FX2N-16CCL-M. |
| ★FX1S/FX1N/FX2N/FX2NC Programming Manual II | JY992D88101 (sent separately) | Explains the instructions available to the FX1S/FX1N/FX2N/FX2NC Series PLC. |
| ★FX3G/FX3U/FX3UC Programming Manual | JY997D16601 (sent separately) | Explains the instructions available to the FX3G/FX3U/FX3UC Series PLC. |
| ☆FX1N Hardware Manual | JY992D89301 (packed with product) | Describes hardware specifications, wiring and mounting of the FX1N Series PLC. |
| ☆FX2N Hardware Manual | JY992D66301 (packed with product) | Describes the contents related to the hardware such as specifications, wiring and mounting of the FX2N Series PLC. |
| ☆FX3G Hardware Manual | JY992D33401 (packed with product) | Describes the name of each part and harding of the FX3G Series PLC. |
| ☆FX3G Series User's Manual - Hardware Edition | JY997D31301 (sent separately) | Describes the contents related to the hardware such as specifications, wiring and mounting of the FX3G Series PLC. |
| ☆FX3U Hardware Manual | JY997D18801 (packed with product) | Describes the name of each part and harding of the FX3U Series PLC. |
| ☆FX3U Series User's Manual - Hardware Edition | JY997D16501 (sent separately) | Describes the hardware specifications, wiring and mounting of the FX3U Series PLC. |
| ☆FX2NC (DSS/S) Hardware Manual | JY992D76401 (packed with product) | Describes the hardware specifications, wiring and mounting of the FX2NC Series PLC. |
| ☆FX2NC (D/UL) Hardware Manual | JY997D87201 (packed with product) | Describes the contents related to the hardware such as specifications, wiring and mounting of the FX2NC Series PLC. |
| ☆FX3U (D,DSS) Hardware Manual | JY992D28601 (packed with product) | Describes the name of each part and harding of the FX3U Series PLC. |
| ☆FX3UC Series User's Manual - Hardware Edition | JY997D28701 (sent separately) | Describes the hardware specifications, wiring and mounting of the FX3UC Series PLC. |
| ☆FX2N-32CCL User's Manual | JY992D71801 (packed with product) | Describes programming and handling of the CC-Link interface block FX2N-32CCL. |

★: Indispensable manual
☆: Manual required depending on equipment used

1.2 Overview

The CC-Link master block FX2N-16CCL-M is a special extension block which assigns an FX Series PLC as the master station of the CC-Link system.

- Remote I/O stations and remote device stations can be connected to the master station (FX Series PLC).
Master station : Station which controls the data link system
Remote I/O station : Remote station which handles only bit information
Remote device station : Remote station which handles both bit information and word information
- By using the CC-Link interface block FX2N-32CCL, two or more FX Series PLCs can be connected as remote device stations to configure a simple distributed system.

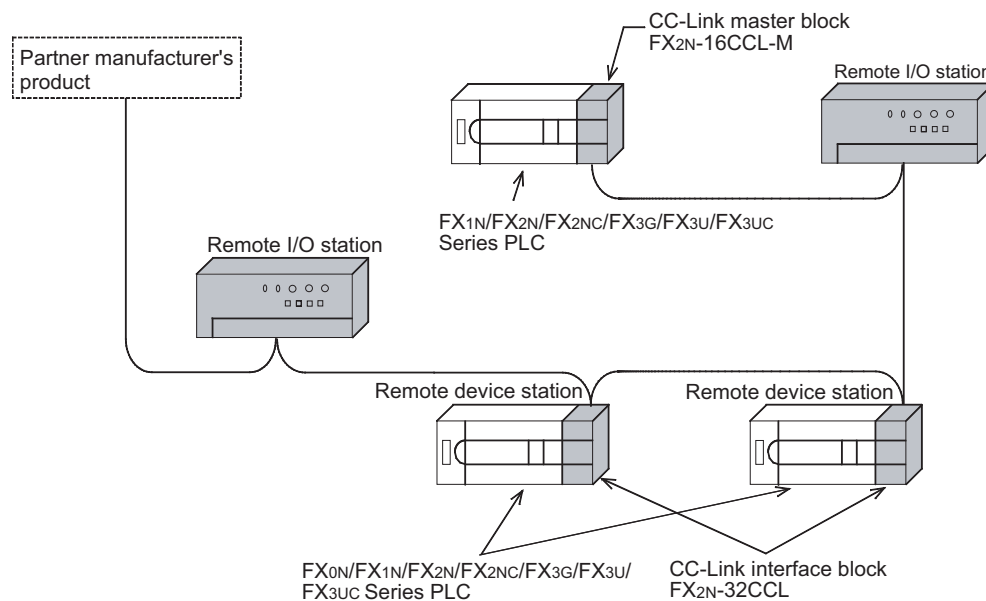

1.3 Dimensions and Setting

Dimensions: mm (inches) MASS (Weight): 0.4 kg (0.88 lbs)

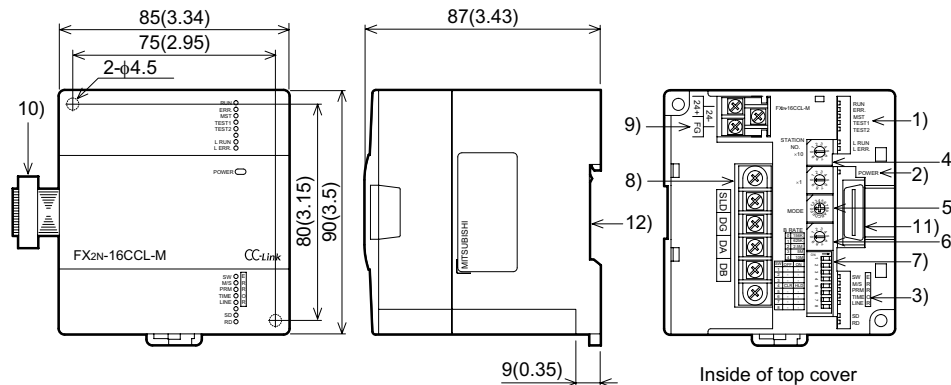

| Number | Name | Description | | | | | |
|--------|------------------|-------------|--|------------------------|---|----|-----|
| | | LED name | Description | LED status | | | |
| 1) | LED indicators 1 | RUN | ON : Module is normal. OFF: Watchdog time error has occurred. | ON | OFF | | |
| | | ERR. | Indicates the communication status with the stations set in the parameters. ON : Communication error has occurred in all stations. Flashing : Communication error has occurred in some stations. | OFF | ON or flashing | | |
| | | MST | ON : Set as the master station | ON | OFF | | |
| | | TEST1 | Test result indication | OFF except during test | | | |
| | | TEST2 | Test result indication | OFF except during test | | | |
| | | L RUN | ON : Data link is being executed (host station). | ON | OFF | | |
| | | L ERR. | ON : Communication error has occurred (host station). Flashing : The settings of the switches 4) to 7) were changed while the power was ON. | OFF | ON or flashing | | |
| | | 2) | Power inductor | POWER | ON : 24V DC is supplied from the outside. | ON | OFF |

| Number | Name | Description | | | |
|--------|---|---|---|--|-------------|
| | | SW | ON | OFF | ON |
| 3) | LED indicators 2 | SW | ON : Switch setting error has occurred. | OFF | ON |
| | | M/S | ON : The master station is already present in the same line. | OFF | ON |
| | | PRM | ON : Parameter setting error has occurred. | OFF | ON |
| | | TIME | ON : Data link watchdog timer errors has occurred (error in all stations). | OFF | ON |
| | | LINE | ON : The cable is broken or the transmission route has been affected by noise, etc. | OFF | ON |
| | | SD | ON : Data is being transmitted. | ON | OFF |
| | | RD | ON : Data is being received.*1 | ON | OFF |
| 4) | Station number setting switch | Sets the station number of the module. (Default setting at shipment: 00) <Setting range> 00 (because the FX2N-16CCL-M is dedicated to the master station) If "65" or larger number is set, the "SW" and "L ERR." LED indicators turn ON. | | | |
| 5) | Mode setting switch | Sets the operation status of the module. (Default setting at shipment: 0) | | | |
| | | Number | Name | Description | |
| | | 0 | Online | Sets connection to data link. | |
| | | 1 | (Unusable) | — | |
| | | 2 | Offline | Sets disconnection from data link. | |
| | | 3 | Line test 1 | Refer to USER'S MANUAL. | |
| | | 4 | Line test 2 | Refer to USER'S MANUAL. | |
| | | 5 | Parameter verification test | Refer to USER'S MANUAL. | |
| | | 6 | Hardware test | Refer to USER'S MANUAL. | |
| | | 7 | (Unusable) | Setting error (The SW LED indicator turns ON.) | |
| 8 to A | (Unusable) | Cannot be set because it is already used inside. | | | |
| B to F | (Unusable) | Setting error (The SW LED indicator turns ON.) | | | |
| 6) | Transmission speed setting switch | Sets the transmission speed of the module. (Default setting at shipment: 0) | | | |
| | | Number | Setting contents | | |
| | | 0 | 156 kbps | | |
| | | 1 | 625 kbps | | |
| | | 2 | 2.5 Mbps | | |
| | | 3 | 5 Mbps | | |
| 4 | 10 Mbps | | | | |
| 5 to 9 | Setting error (The SW and L ERR. LED indicators turn ON.) | | | | |
| 7) | Condition setting switch | Sets the operation condition. (Default setting at shipment: All OFF) | | | |
| | | Number | Setting description | Switch status | |
| | | SW1 to SW3 | (Unusable) | Always OFF | |
| | | SW4 | Input data status in data link faulty station | Keep (HLD) | Clear (CLR) |
| | | SW5 to SW8 | (Unusable) | Always OFF | |
| 8) | Terminal block | Connects dedicated CC-Link cables to enable data link. For the connection method, refer to Section 2.3. | | | |
| | | The terminals SLD and FG are connected inside. M3.5 Screw | | | |
| 9) | Terminal block | Connects the power supply to operate the master block. M3 Screw | | | |
| 10) | Extension cable | Connects the PLC. | | | |
| 11) | Next step extension connector | Connects extension equipment. | | | |
| 12) | DIN rail mounting groove | DIN46277: DIN rail mounting groove of 35 mm (1.38") in width | | | |

*1 The [RD] LED is darker as the transmission speed is faster and as the number of connected stations is smaller.

2. Installation and wiring

INSTALLATION PRECAUTIONS

- Use the module in the environment described in the USER'S MANUAL General Specification. Do not use the PLC in places with dust, soot, conductive dust, corrosive gas or combustible gas, places exposed to high temperature, condensation, wind or rain or places that experience vibration or impact. Using the module outside the range of the general specification may result in electrical shock, fire, malfunctions, or damage to the PLC.
- When drilling screw holes or performing wiring, make sure that cutting and wiring debris or other foreign matter do not enter the ventilation slits of the module. Such matter may cause fire, failure or malfunction.
- When the installation work is completed, remove the dust protection sheet from the ventilation slits of the PLC. If the sheet remains attached, it may cause fire, failure or malfunction.
- Securely connect extension cables to their specified connectors. Poor contact may cause malfunction.

WIRING PRECAUTIONS

- Before beginning any installation or wiring work, make sure all phases of the power supply have been shut off. Failing to shut off the power supply may cause electrical shock or damage to the module.
- Following installation or wiring work, when turning on the power supply and operating the PLC, make sure that the terminal cover provided as an accessory has been attached to the module. Failing to attach the cover may cause electrical shock.
- For the CC-Link system, use dedicated cables specified by the manufacturer. The performance of the CC-Link system cannot be guaranteed with any cable other than dedicated ones specified by the manufacturer. For the maximum total extension length and the cable length between stations, observe the specifications described in USER'S MANUAL. With wiring outside the specification range, normal data transfer cannot be guaranteed.
- Make sure to fix communication cables and power cables connected to the module by placing them in a duct or clamping them. Cables not placed in a duct or left unclamped may hang or shift, allowing them to be pulled accidentally, which may result in malfunction or damage to the module and the cables.
- When disconnecting a communication/power cable connected to the module, do not hold the cable area. For a cable with a connector, hold the connector attached to the cable. For a cable connected to a terminal block, loosen screws of the terminal block before disconnecting the cable. If a cable is pulled while it is connected to a module, the module may malfunction or the module and the cable may be damaged.

WIRING PRECAUTIONS

- Use a grounding resistor of 100Ω or less with a wire of 2 mm² or more to ground the grounding terminal in the PLC main units. However, never perform common grounding with a high voltage system.

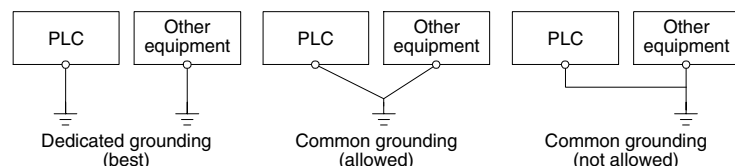

- Do not bundle control cables and communication cables with the main circuit and power cables. Keep control cables and communication cables at least 100 mm away from the main circuit and power cables. Otherwise, electric noise may cause a malfunction.

2.1 Installation

Install the FX2N-16CCL-M on the right side of the FX1N/FX2N/FX2NC/FX3G/FX3U/FX3UC Series main unit, extension unit or another extension block. (For the FX2NC Series, the FX2NC-CNV-IF is required. For the FX3UC Series, the FX2NC-CNV-IF or FX3UC-1PS-5V is required.) The FX2N-16CCL-M can be installed using a DIN rail (DIN 46277, width: 35 mm (1.38 in.)) or directly with M4 (0.16 in.) screws. In the case of direct installation, provide a space of 1 to 2 mm (0.04 to 0.08 in.) between the units.

2.2 Dedicated CC-Link Cables

Use dedicated CC-Link cables in the CC-Link system. If any other cable is used, the performance of the CC-Link system cannot be guaranteed.

2.3 Module Wiring with Dedicated CC-Link Cables

This section describes the connection method of dedicated CC-Link cables.

- The cables can be connected regardless of the station number.
- Make sure to connect a terminal resistor (offered as an accessory to the module) between the terminals DA and DB in the modules at both ends of the CC-Link system.
- In the CC-Link system, the terminal resistor required varies depending on the cable used.
 - When a dedicated CC-Link cable is used: 110 Ω, 1/2 W (brown, brown and brown)
 - When a dedicated high-performance CC-Link cable is used: 130 Ω, 1/2 W (brown, orange and brown)
- The master module can be connected at either end of the system.
- Star configuration is not allowed.
- The figure below shows the connection method.

| Important |
|---|
| Make sure to use only one type of cable (dedicated CC-Link cables OR dedicated CC-Link high-performance cables). If both types of cables are used together, normal data transmission cannot be guaranteed. |

| Point |
|--|
| The shielded dedicated CC-Link cable should go through the terminals SLD and FG in each module, and both ends should be grounded (Class D = solid grounding). The terminals SLD and FG are connected to each other inside the module. |

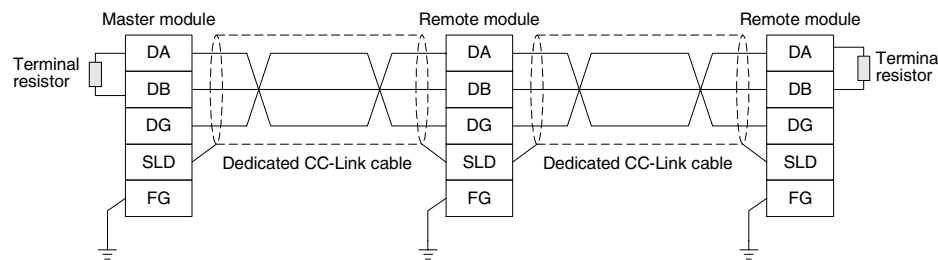

3. SPECIFICATION

3.1 Power Supply Specification

| Item | Specification |
|------------------------------|--|
| 24V DC external power supply | Supplied from a 24V DC (150 mA) external terminal block. |
| 5V DC internal power supply | 5V DC of PLC is not used. (5V DC is converted from 24V DC external power supply.) |

3.2 General Specification

Dielectric strength: 500V AC for 1 minute (between the case and the PLC ground)
Other specification is equivalent to that of the PLC main unit.

3.3 Performance Specification

| Item | Specification |
|--|---|
| Applicable function | Master station function (The local station and standby master station functions are not provided.) |
| CC-Link version | Ver.1.10 |
| Transmission speed | Selectable (by rotary switch): 156 kbps, 625 kbps, 2.5 Mbps, 5 Mbps or 10 Mbps |
| Station number | 0 (set by rotary switch) |
| Maximum total cable length (maximum transmission distance) | 1,200 m maximum Varies depending on the transmission speed. (Refer to USER'S MANUAL.) |
| Maximum number of connected modules | <ul style="list-style-type: none"> Remote I/O stations: 7 maximum (Each station occupies 32 I/O points of the PLC.) Remote device stations: 8 maximum (The following condition must be satisfied.) $\{(1 \times a) + (2 \times b) + (3 \times c) + (4 \times d)\} \leq 8$ <ul style="list-style-type: none"> a: Number of remote device stations occupying 1 station b: Number of remote device stations occupying 2 stations c: Number of remote device stations occupying 3 stations d: Number of remote device stations occupying 4 stations Number of remote I/O stations + Number of remote device stations ≤ 15 "Maximum number of I/O points per system" below shall be satisfied. For the system configuration calculation, refer to the USER'S MANUAL. |
| Maximum number of I/O points per system | <p>[When using an FX3U, FX3UC (Ver. 2.20 or later) Series PLC]</p> <ul style="list-style-type: none"> 1) (Actual number of PLC I/O points) + (Number of points occupied by special function blocks) + (Number of points occupied by FX2N-16CCL-M: 8) ≤ 256 2) (32 × Number of remote I/O modules) ≤ 224 1)+2) total number of points ≤ 384 <p>[When using an FX3G Series PLC]</p> <ul style="list-style-type: none"> (Actual number of PLC I/O points) + (Number of points occupied by special function blocks) + (Number of points occupied by FX2N-16CCL-M: 8) ≤ 128 (32 × Number of remote I/O modules) ≤ 128 <p>[When using an FX2N, FX2NC or a FX3UC (Ver. 2.20 or less) Series PLC]</p> <p>Connection is allowed as far as the following condition is satisfied:</p> <ul style="list-style-type: none"> (Actual number of PLC I/O points) + (Number of points occupied by special function blocks) + (Number of points occupied by FX2N-16CCL-M: 8) + (32 × Number of remote I/O modules) ≤ 256 <p>[When using an FX1N, FX1NC Series PLC]</p> <p>Connection is allowed as far as the following condition is satisfied:</p> <ul style="list-style-type: none"> (Actual number of PLC I/O points) + (Number of points occupied by special function blocks) + (Number of points occupied by FX2N-16CCL-M: 8) + (32 × Number of remote I/O modules) ≤ 128 For the system configuration calculation, refer to Chapter 3. |
| Number of link points per station | Remote I/O station : Remote I/O = 32/32 (RX/RX) points Remote device station : Remote I/O = 32/32 (RX/RX) points Remote register = 4 (RWw) points (master station → remote device station) Remote register = 4 (RWr) points (remote device station → master station) |
| Communication method | Polling method |

| Item | Specification |
|---|---|
| Synchronous method | Frame synchronous method |
| Encoding method | NRZI method |
| Transmission path type | Bus (RS-485) |
| Transmission format | In conformance to HDLC Standard |
| Error control method | CRC(X ¹⁶ +X ¹² +X ⁵ +1) |
| Connection cable | Dedicated CC-Link cable/Dedicated high-performance CC-Link cable *1 |
| RAS function | <ul style="list-style-type: none"> Automatic return function Slave station cutoff function Error detection by link special relay/register |
| Number of times of parameter registration to EEPROM | Approximately 10,000 times |
| Connectable PLC | FX1N, FX2N (V 2.20 or later), FX3U, FX2NC (V 2.20 or later) *2, FX3G, FX3UC *3 Series PLC |
| Number of occupied I/O points | <ul style="list-style-type: none"> 8 I/O points of FX Series PLC (8 points in total. The ratio between inputs and outputs is arbitrary.) When remote I/O station is connected, 32 points per station are occupied. |
| Communication with PLC | By FROM and TO instructions or direct specification of buffer memory (FX3U/FX3UC) via the buffer memory |
| Note | <ul style="list-style-type: none"> Scan method: Asynchronous mode Automatic refresh: Not provided Local station function: Not provided Standby master station function: Not provided Intelligent device station connection function: Not provided FX2N-32ASI-M AS-i master block: Cannot be connected concurrently. |
| Operation indication | POWER : Lit while 24V DC is supplied from outside. L RUN : Lit while communication is normal. L ERR : Lit when communication error has occurred. SD : Lit while data is being transmitted. RD : Lit while data is being received. *4 |
| Accessories | Terminal resistor <ul style="list-style-type: none"> For standard cable: 110 Ω, 1/2 W (color cable: brown, brown and brown), 2 cables For high performance cable: 130 Ω, 1/2 W (color cable: brown, orange and brown), 2 cables Special block number label |
| MASS (Weight) | 0.4 kg (0.88 lbs) |

*1 Dedicated CC-Link cables and dedicated high-performance CC-Link cables cannot be used at the same time. Attach a terminal resistor in accordance with the cable type.

*2 When an FX2NC Series PLC is connected, the interface FX2NC-CNV-IF is required.

*3 When an FX3UC Series PLC is connected, the interface FX2NC-CNV-IF or FX3UC-1PS-5V is required.

*4 The [RD] LED is darker as the transmission speed is faster and as the number of connected stations is smaller.

This manual confers no industrial property rights or any rights of any other kind, nor does it confer any patent licenses. Mitsubishi Electric Corporation cannot be held responsible for any problems involving industrial property rights which may occur as a result of using the contents noted in this manual.

Warranty

Mitsubishi will not be held liable for damage caused by factors found not to be the cause of Mitsubishi; opportunity loss or lost profits caused by faults in the Mitsubishi products; damage, secondary damage, accident compensation caused by special factors unpredictable by Mitsubishi; damages to products other than Mitsubishi products; and to other duties.

For safe use

- This product has been manufactured as a general-purpose part for general industries, and has not been designed or manufactured to be incorporated in a device or system used in purposes related to human life.
- Before using the product for special purposes such as nuclear power, electric power, aerospace, medicine or passenger movement vehicles, consult with Mitsubishi Electric.
- This product has been manufactured under strict quality control. However when installing the product where major accidents or losses could occur if the product fails, install appropriate backup or failsafe functions in the system.

Manual number : JY992D93201

Manual revision : D

Date : JUN. 2010

MITSUBISHI ELECTRIC CORPORATION

HEAD OFFICE : TOKYO BUILDING, 2-7-3 MARUNOUCHI, CHIYODA-KU, TOKYO 100-8310, JAPAN
HIMEJI WORKS : 840, CHIYODA CHO, HIMEJI, JAPAN

JY992D93201D

Effective JUN. 2010
Specifications are subject to change without notice