

# **MELSEC FX Series**

Programmable Controller

User's Manual

## **FX-485PC-IF Interface Unit**

## **Foreword**

- This manual contains text, diagrams and explanations which will guide the reader in the correct installation and operation of the 485PC-IF Interface Unit and should be read and understood before attempting to install or use the unit.
- If in doubt at any stage during the installation of the 485PC-IF Interface Unit always consult a professional electrical engineer who is qualified and trained to the local and national standards. If in doubt about the operation or use of the 485PC-IF Interface Unit please consult the nearest Mitsubishi Electric distributor.
- This manual is subject to change without notice.

# FX-485PC-IF RS485 Interface Unit

## User's Manual

Manual number: JY992D53501  
Manual revision: A  
Date: December 1995



## Guidelines for the safety of the user and protection of the FX-485PC-IF RS-485 Interface Unit

This manual provides information for the installation and use of the FX-485PC-IF RS-485 interface unit. The manual has been written to be used by trained and competent personnel. The definition of such a person or persons is as follows;

- a) Any engineer who is responsible for the planning, design and construction of automatic equipment using the product associated with this manual should be of a competent nature, (trained and qualified to the local and national standards required to fulfill that role). These engineers should be fully aware of all aspects of safety with regards to automated equipment.
- b) Any commissioning or service engineer must be of a competent nature, trained and qualified to the local and national standards required to fulfill that job. These engineers should also be trained in the use and maintenance of the completed product. This includes being completely familiar with all associated documentation for the said product. All maintenance should be carried out in accordance with established safety practices.
- c) All operators of the compliance product should be trained to use that product in a safe and coordinated manner in compliance to established safety practices. The operators should also be familiar with all documentation which is connected with the actual operation of the completed equipment.

Note: the term 'completed equipment' refers to a third party constructed device which contains or uses the product associated with this manual.

### Note's on the symbology used in this manual

At various times through out this manual certain symbols will be used to highlight points of information which are intended to ensure the users personal safety and protect the integrity of the equipment. Whenever any of the following symbols are encountered, its associated note must be read and understood. Each of the symbols used will now be listed with a brief description of its meaning.

#### Hardware warnings



1) Indicates that the identified danger WILL cause physical and property damage.



2) Indicates that the identified danger could POSSIBLY cause physical and property damage.



3) Indicates a point of further interest or further explanation.

#### Software warnings



4) Indicates special care must be taken when using this element of software.



5) Indicates a special point of which the user of the associate software element should be aware.



6) Indicates a point of interest or further explanation.

# Contents

<b>1. Outline and system configuration</b> .....	<b>1-1~1-6</b>
1.1 Outline .....	1-1
1.1.1 Product interaction .....	1-1
1.1.2 Communications Outline .....	1-2
1.1.3 Functions .....	1-2
1.1.4 System configuration and number of link stations .....	1-3
1.2 System configuration .....	1-4
1.2.1 Computer and PC in 1:1 system configuration .....	1-4
1.2.2 Computer and PC in 1:n system configuration .....	1-4
1.2.3 Applicable PCs .....	1-5
1.2.4 Applicable functions in system configurations .....	1-5
<b>2. Specification</b> .....	<b>2-1~2-4</b>
2.1 Environmental specifications .....	2-1
2.2 Power source specifications and insulation .....	2-1
2.2.1 Power source specifications of 485PC-IF .....	2-1
2.2.2 485PC-IF isolation .....	2-1
2.3 Performance specifications .....	2-2
2.3.1 RS-232C connector specifications .....	2-2
2.3.2 RS-485 terminal block specifications .....	2-2
2.3.3 Cable specification .....	2-2
2.3.4 Transmission characteristics of the PC .....	2-3
2.4 Data communication function .....	2-3
2.5 Dimensions and Part Names .....	2-4
2.5.1 FX-485PC-IF Dimensions .....	2-4
2.5.2 Power feed plug specifications .....	2-4
<b>3. Settings and procedures before operation</b> .....	<b>3-1~3-10</b>
3.1 Procedures before operation .....	3-1
3.2 Setting of transmission specifications and transmission control protocol .....	3-2
3.2.1 Setting of transmission specifications .....	3-2
3.2.2 Setting of transmission control protocol .....	3-2
3.3 Setting of station number .....	3-3
3.4 Setting of time-out check time .....	3-3
3.5 Cautions for connection of 485PC-IF and power source unit .....	3-4
3.6 External wiring .....	3-4
3.6.1 Cautions for wiring .....	3-4
3.6.2 Connecting to a computer .....	3-5
3.6.3 Connecting to a PC .....	3-5
3.7 Connection of terminating resistance .....	3-8
3.7.1 Classification of terminating resistances .....	3-8
3.7.2 When connecting computer and PC by 1:1 .....	3-8
3.7.3 When connecting computer and PCs by 1:n .....	3-8
3.8 Loopback test .....	3-9
3.9 Operation, maintenance and checking .....	3-9
3.9.1 Operation .....	3-9
3.9.2 Maintenance, checking .....	3-9

<b>4. Communication using dedicated protocols .....</b>	<b>4-1~4-14</b>
4.1 Data flow by link.....	4-1
4.2 Information needed before programming.....	4-2
4.2.1 PC operation during data communication .....	4-2
4.2.2 Precautions during data communication .....	4-2
4.3 How to read a control protocol diagram .....	4-2
4.4 Basic formats of dedicated protocol .....	4-3
4.4.1 Control protocol format 1 .....	4-4
4.4.2 Control protocol format 4 .....	4-5
4.4.3 Control Protocol parts explained .....	4-6
4.4.4 Error code .....	4-8
4.5 Communication Timing chart .....	4-9
4.5.1 When reading data from the PC to the computer (with the message wait time set) .....	4-9
4.5.2 When writing data from the computer to the PC (with the message wait time set) .....	4-9
4.5.3 Communication Time .....	4-10
4.6 Character area data transmission .....	4-11
4.6.1 When reading or writing bit device memory .....	4-11
4.6.2 When reading or writing word device memory .....	4-12
4.7 Commands and Device ranges .....	4-13
4.7.1 Commands .....	4-13
4.7.2 Device specification ranges .....	4-14
<b>5. Commands .....</b>	<b>5-1~5-18</b>
5.1 Batch read of device memory, bit units (BR command) .....	5-2
5.2 Batch read of device memory, word units (WR command) .....	5-3
5.3 Batch write of device memory, bit units (BW command) .....	5-4
5.4 Batch write of device memory, word units (WW command) .....	5-5
5.5 Test of device memory, bit unit (selective write) (BT command) .....	5-6
5.6 Test of device memory, word units (selective write) (WT command) .....	5-7
5.7 Remote run/stop with PC (RR, RS commands) .....	5-8
5.7.1 Operation of remote run/stop .....	5-8
5.7.2 Conditions for valid execution of remote run/stop .....	5-8
5.7.3 Control specification and examples of remote run/stop .....	5-9
5.8 Reading the PC type name (PC command) .....	5-10
5.8.1 PC type codes .....	5-10
5.8.2 Control specification and example .....	5-10
5.9 Global function (GW command) .....	5-11
5.9.1 Control specification and example of global function .....	5-11
5.10 On-demand function .....	5-12
5.10.1 Special devices used in on-demand function .....	5-12
5.10.2 On-demand Control protocol .....	5-13
5.10.3 Specification and example of on-demand .....	5-15
5.11 Loopback test .....	5-18
<b>6. Diagnostics .....</b>	<b>6-1~6-6</b>
6.1 NAK Error codes.....	6-1
6.2 PC Error codes .....	6-1
6.3 Diagnostics .....	6-2
6.3.1 Diagnostic Flow Chart.....	6-2
6.3.2 Computer does not receive data .....	6-3
6.3.3 PC error flag M8063 is ON .....	6-4
6.3.4 Communication fails sometimes .....	6-5
<b>Appendix A .....</b>	<b>A-1~A-3</b>
Example computer program for Loopback command .....	A-1



<b>1</b>	<b>Outline and system configuration</b>
<b>2</b>	<b>Specification</b>
<b>3</b>	<b>Settings and produres before operation</b>
<b>4</b>	<b>Communication using dedicated protocols</b>
<b>5</b>	<b>Commands</b>
<b>6</b>	<b>Diagnostics</b>
	<b>Appendix A</b>



# 1. Outline and system configuration

The User's Manual describes the specification, handling, and transmission control procedure of the FX-485PC-IF RS485 interface unit (hereinafter called 485PC-IF).

## 1.1 Outline

### 1.1.1 Product interaction

The products of a computer link system using the 485PC-IF are shown below.

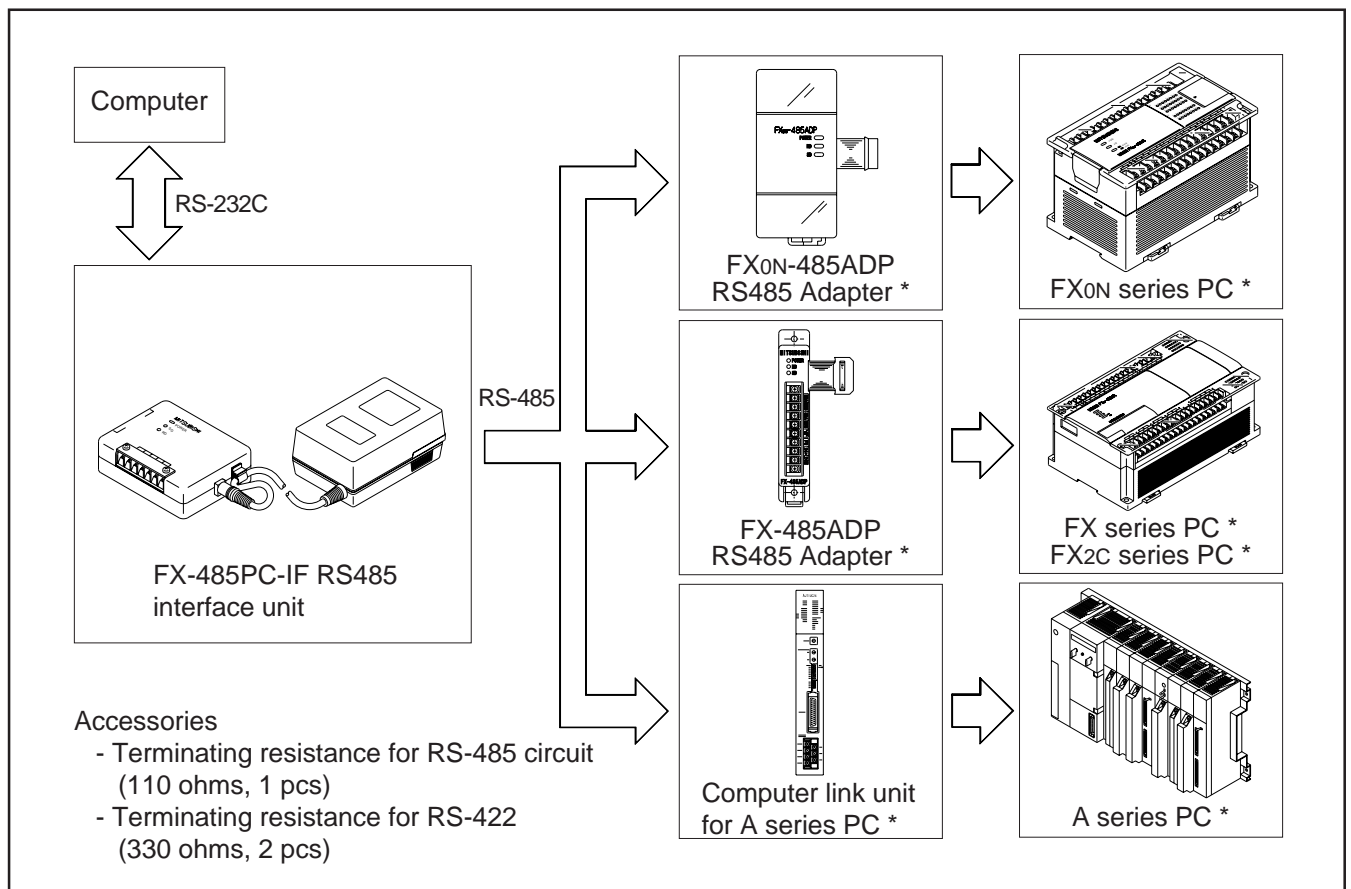

\* : For specification and handling see the appropriate manual.



#### Notes

- The 485PC-IF is an interface for RS-485 communication circuit. However, if RS-422 devices are included in the computer link system, it can be used as an interface for RS-422 communication by changing the wiring method and terminating resistances.  
For wiring method, see section 3.6.3.  
For terminating resistances, see section 3.7.

### 1.1.2 Communications Outline

The 485PC-IF has an RS-232C port for connection with the computer, and an RS-485 terminal block for connection with the PC, and is designed as an interface unit for converting the RS-232C signal of the computer into an RS-485 signal.

A dedicated protocol is used in the transmission control procedure for linking the PC and the computer. The transmission data of the dedicated protocol is communicated in ASCII code as shown below.

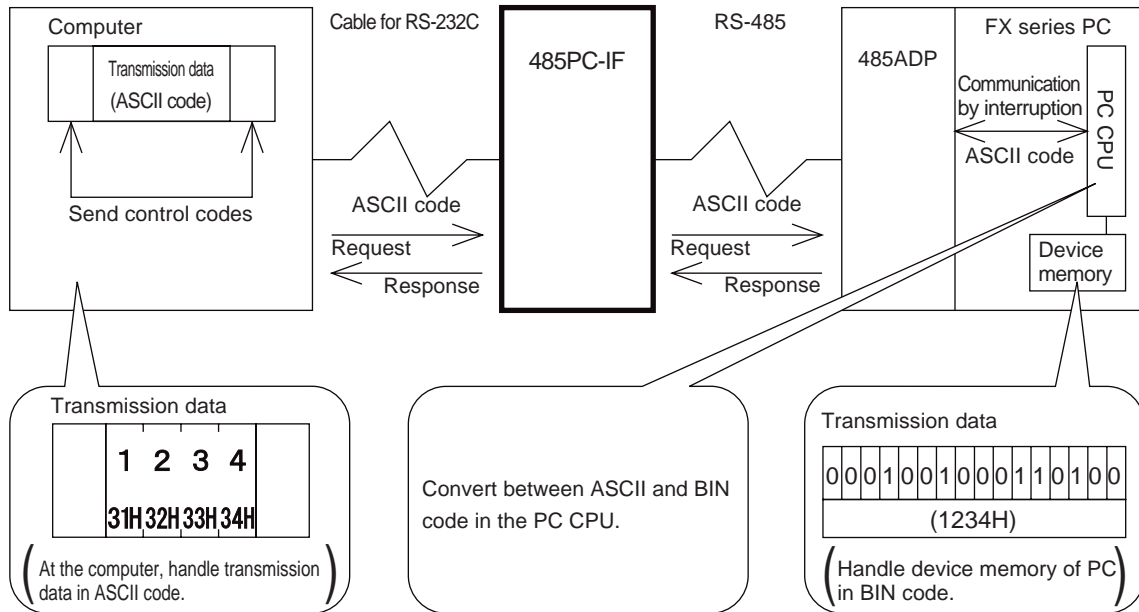

### 1.1.3 Functions

For linking a computer with the PC, the FX<sub>(ON)</sub>-485ADP adapter for RS485 (485ADP hereinafter) is used with the FX series PC. The data communication functions between the PC and the computer using the 485ADP and 485PC-IF include the following.

(1) Data communication by request from the computer

The computer requests data transmission.

By sending a request command from the computer to the PC, specified data is transmitted.

To use the 485PC-IF or 485ADP, no particular PC program is needed (except for the global function and on-demand function).

1) Batch reading or writing of all devices of the PC (word unit, bit unit) is possible.

By reading the device data of the PC, the running state can be monitored, or the data can be acquired or analyzed.

By writing data into devices, production control or production instruction can be done.

2) Remote run/stop of PC.

The programmable controller is remote controllable from the computer with remote run/stop command to a stopped programmable controller.

3) Batch command can be issued to all PCs.

When one computer and several PCs are connected, the computer can control the on/off state of a specific device in all PCs on the circuit in batch (special auxiliary relay M8126\* in the case of FX series PC, input signal (x) in the case of A series PC). This function is called the global function.

\* This special auxiliary relay M8126 is the dedicated device for the global function.

- (2) Data communication by request from PC  
 The PC requests data communication.  
 If transmission of emergency data from the PC to the computer is needed, this is a function for interrupting the computer by sending a transmission request from the PC.  
 This function is called on-demand function, which can be executed only when the system configuration of the computer and PC is 1:1.

### 1.1.4 System configuration and number of link stations

The computer link system configuration of a computer and PC can be either 1:1 or 1:n. However, as mentioned above, the on-demand function is available in 1:1 configuration only. The maximum number of link stations is 16 for a total system of FX series PCs and A series PCs on one circuit in the 1:n configuration\*.

\* This is a method of exchanging data between one computer and several PCs. It is also known as multidrop link system.

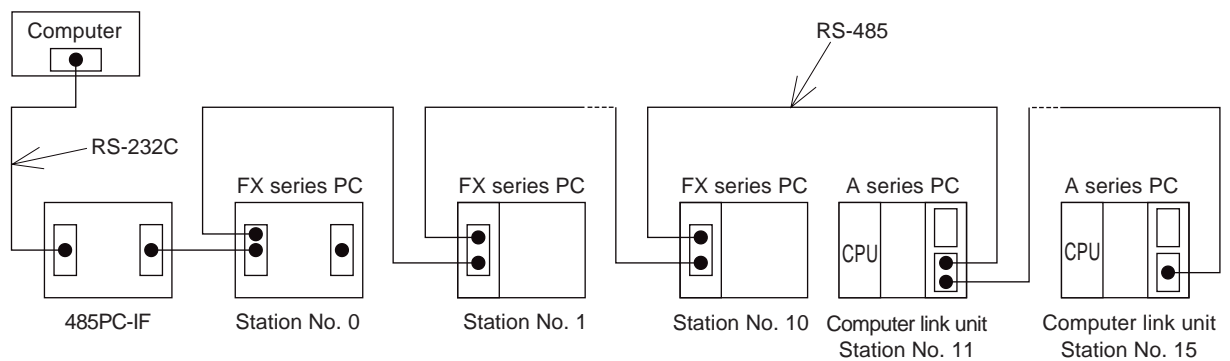

#### Notes

- The FX series PCs and A series PCs are shown separately in the diagram for the sake of simplicity, but actually they can be linked in any order. The station numbers may be either regular or irregular. For detail of system configuration, see section 1.2. For detail of station numbers, see section 3.3.

## 1.2 System configuration

In a system configuration using the 485PC-IF, the computer and PCs are connected as either 1:1 or 1:n, and for communication with the PC, the signals conform to RS-485\*. This configuration is described below. For the A series PC, see the corresponding manual.

### 1.2.1 Computer and PC in 1:1 system configuration

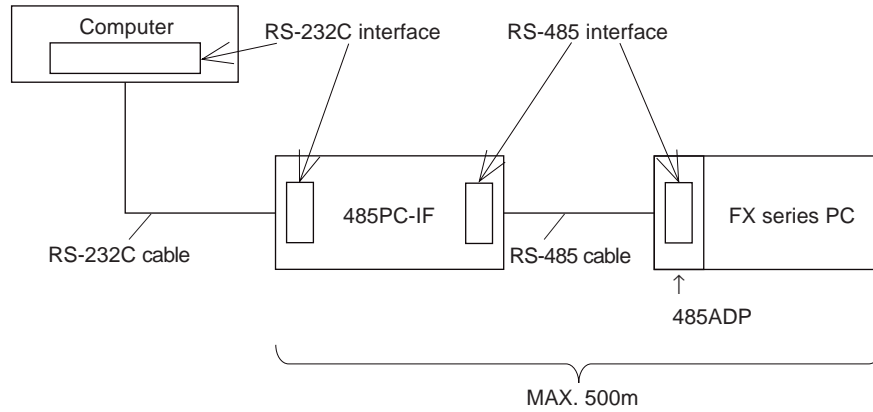

### 1.2.2 Computer and PC in 1:n system configuration

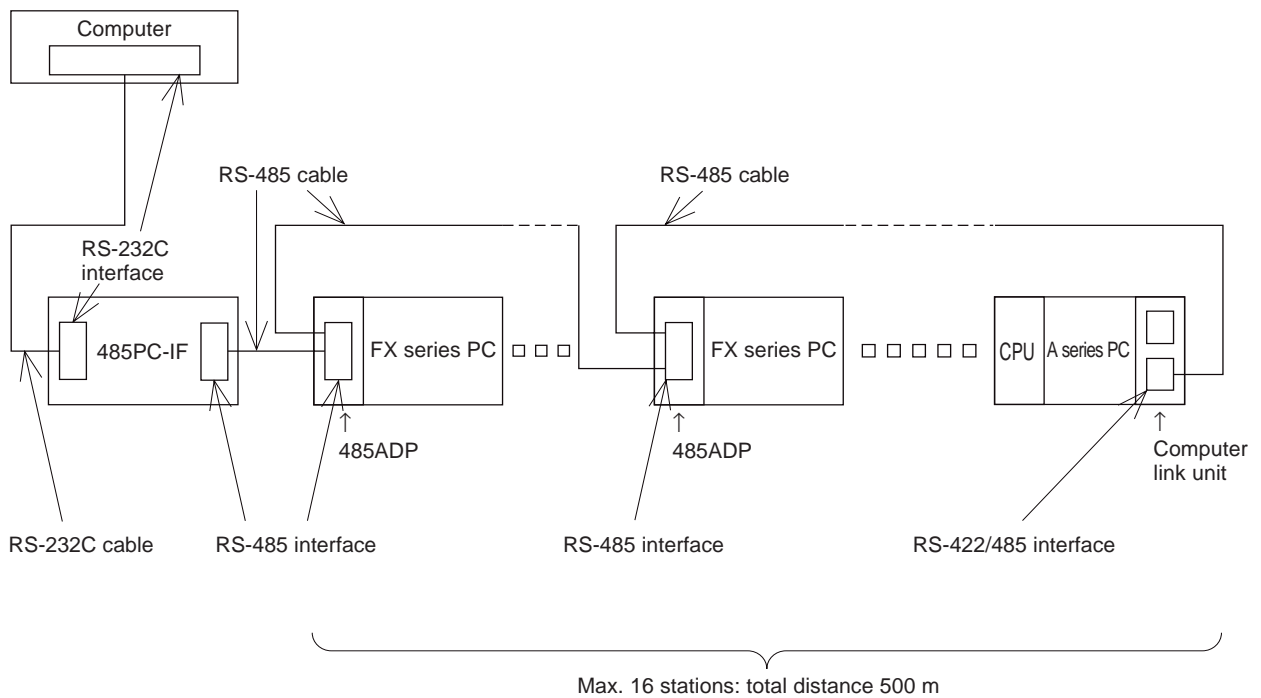

### 1.2.3 Applicable PCs

The 485PC-IF is used with the following PCs.

(1) FX series PCs

PC type	Applicable version	Remarks
FX0N series PC	V1.20 or later	Dedicated protocol format 1 and format 4 supported.
FX, FX2C series PC	V3.30 or later	Dedicated protocol format 1 and format 4 supported.

(2) A series PCs

In the A series PCs, the following CPUs are applicable.

A0J2H, A1, A1N, A1S(J), A2(-S1), A2N(-S1), A2S, A3, A3N, A3H, A3M, A73, A2A(-S1), A3A, A2U(-S1), A3U, A4U, A2US(-S1), A1SCPU24-R2, A52G, A7LMS-F

For details see the A series manual.

### 1.2.4 Applicable functions in system configurations

Functions usable in the FX series PCs in each system configuration are explained below.

For the A series PCs see the appropriate manual.

(1) Functions available from the computer

Usable function		System configuration	
		1:1	1:n
Device memory	Read/write	○	○
	Test	○	○
PC	Remote run/stop	○	○
	Read PC name	○	○
Global	On/off of special auxiliary relay M8126	○	○
Loopback test	Transmission of received data	○	○

(2) Functions available from the PC

Usable function		System configuration	
		1:1	1:n
On-demand	Data transmission to computer	○	×



<b>1</b>	<b>Outline and system configuration</b>
<b>2</b>	<b>Specification</b>
<b>3</b>	<b>Settings and produres before operation</b>
<b>4</b>	<b>Communication using dedicated protocols</b>
<b>5</b>	<b>Commands</b>
<b>6</b>	<b>Diagnostics</b>
	<b>Appendix A</b>



## 2. Specification

This chapter describes the environmental specifications, performance specification, and functions of the FX-485PC-IF.

### 2.1 Environmental specifications

Ambient temperature	Operating: 0 to 55°C, storing: -20 to 70°C.	
Ambient humidity	Operating: 35 to 85% (with no condensation).	
Vibration resistance	Conforming to JIS C 0911: 10 to 55 Hz, 0.5 mm (max. 2G), 2 hours each in 3 axes.	
Shock resistance	Conforming to JIS C 0912: 10 G, 3 times each in 3 axes.	
Noise immunity	Noise voltage 1000 Vp-p, noise width 1 μ sec, period 30 to 100 Hz, by noise simulator.	
Withstand voltage	500 VAC, 1 min	between terminals in batch and case
Insulation resistance	5 M Ω or more by 500 VDC megger	
Operating ambience	Free from corrosive gas, minimal dust.	

### 2.2 Power source specifications and isolation

#### 2.2.1 Power source specifications of 485PC-IF

Power source	5 VDC ± 5%
Current consumption	Max. 260 mA

#### 2.2.2 485PC-IF isolation

The 485PC-IF has photo coupler isolation and transformer isolation between PC and communication signal.

## 2.3 Performance specifications

### 2.3.1 RS-232C connector specifications

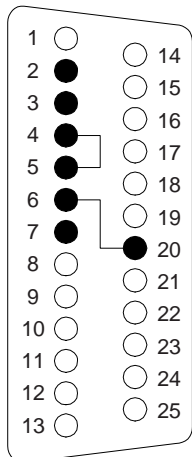

Pin No.	Description	Signal Abbreviation	Signal direction	
			485PC-IF	↔ computer
2	Send data	SD(TXD)	→	→
3	Receive data	RD(RXD)	←	←
4	Not used (short-circuited with pin 5)	RS(RTS)	→	→
5	Not used (short-circuited with pin 4)	CS(CTS)	←	←
6	Not used (short-circuited with pin 20)	DR(DSR)	←	←
7	Signal ground	LINK SG	↔	↔
20	Not used (short-circuited with pin 6)	ER(DTR)	→	→

A 25-pin D sub (female) connector is used.

### 2.3.2 RS-485 terminal block specifications

(1) Terminal block of 485PC-IF

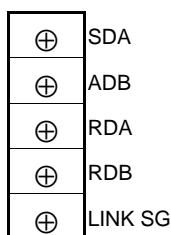

Signal abbreviation	Signal direction		Remarks
	485PC-IF	↔ PC	
SDA	→	→	Send data
SDB	→	→	Send data
RDA	←	←	Receive data
RDB	←	←	Receive data
LINK SG	↔	↔	Signal ground

(2) Function block diagram of RS-485

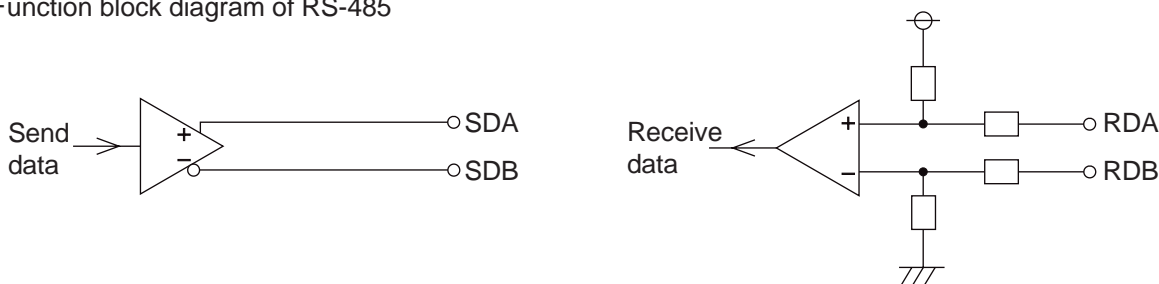

### 2.3.3 Cable specification

The RS-422/485 cable used should conform to the following specifications.

Item	Description
Cable type	Shielded cable
Number of pairs	3
Conductor resistance(20°C)	88 Ω /km or less
Insulation resistance	10 Ω /km
Withstand voltage	500V DC, 1 min
Electrostatic capacity (1 kHz)	Average: 60nF/km or less
Characteristic impedance(100 kHz)	110 ± 10 Ω

(Recommended cable)

SPEV(SB)-MPC-0.2X0.3

SPEV(SB)-0.2X3P

(Manufactured by Mitsubishi Cable Industries, Ltd.)

The recommended cables are identical in electric characteristic, but differ partly in the outside diameter and internal wire color.

## 2.3.4 Transmission characteristics of the PC

Item		Specifications	
Interface		Conforms to RS-422/485	
Communication method		Dedicated protocol, half duplex communication method	
Synchronizing method		Start-stop synchronizing method	
Transmission speed		300, 600, 1200, 2400, 4800, 9600, 19200 bps	
Data format	Start bit	1	
	Data bit	7 or 8	
	Parity bit	1 or none	
	Stop bit	1 or 2	
Error detection	Parity check	Odd / Even / None	
	Sum check	Yes / No	
Access cycle		Each request is processed during the END processing of the PC program. Therefore, access cycle is one scan time.	
System Configuration (Computer: PC)		1:1 or 1:n ( n = 0~15 (MAX. 16 stations))	
Transmission distance	RS-485 RS-422	Total distance up to 500 m	
	RS-232C	Up to 15 m	

## 2.4 Data communication function

			Command		Description	Maximum No. of units per communication	
			Symbol	ASCII code		FX0N	FX2C
Device memory	Batch read	Bit units	BR	42H,52	Reads a group of bit devices (X, Y, M, S, T, C), result is in units of 1 device.	54 points	256 points
		Word units	W	57H,52	Reads a group of bit devices (X, Y, M, S), result is in units of 16 devices.	13 words, 208 points	32 words, 512 points
					Reads a group of word devices (D, T, C), result is in units of 1 device.	13 points	64 points
	Batch write	Bit units	B	42H,57	Writes a group of bit devices (X, Y, M, S, T, C), data is in units of 1 device.	46 points	160 points
		Word units	W	57H,57	Writes a group of bit devices (X, Y, M, S), data is in units of 16 devices.	10 words, 160 points	10 words, 160 points
					Writes a group of word devices (D, T, C), data is in units of 1 device.	11 points	64 points
	Test (select write)	Bit units	BT	42H,54	Set/reset individual bit devices (X, Y, M, S, T, C) selectively in units of 1 device.	10 points	20 points
		Word units	W	57H,54	Set/reset bit devices (X, Y, M, S) selectively in units of 16 devices.	6 words, 96 points	10 words, 160 points
					Write word devices (D, T, C*) selectively in units of 1 device.	6 points	10 points
PC	Remote run	R	52H,52	Remote run/stop request to PC	---	---	
	Remote stop	RS	52H,53				
	PC type read	PC	50H,43				PC type name (code) is read.
Global	G	47H,57	Set/reset the global flag (M8126 for FX series) to all connected PCs.	1 points	1 points		
On-demand	---	---	Send request from PC. Possible, however, only in 1:1 system configuration.	Maximum 13 words	Maximum 64 words		
Loopback test	TT	54H,54	Characters received from the computer are directly sent back to the computer.	25 characters	254 characters		

\* Counter except high speed (32-bit) counters C200 to C255.

## 2.5 Dimensions and Part Names

The FX-485PC-IF consists of the 485PC-IF (interface) and terminating resistors.

### 2.5.1 485PC-IF Dimensions

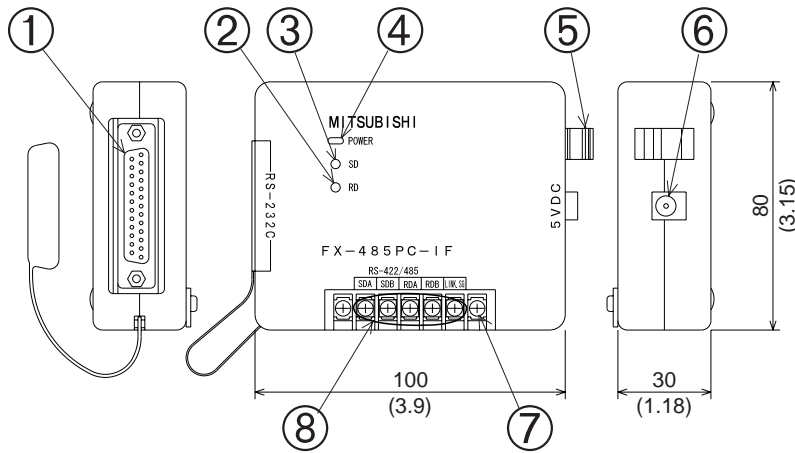

Weight: Approx. 0.3 kg (0.66 lbs)  
Units: mm(inches)

- ①RS-232C connector ..... Used for connection between 485PC-IF and computer.
- ②RD LED ..... Lit when the PC sends data to the computer.
- ③SD LED ..... Lit when the PC receives data from the computer.
- ④POWER LED ..... Lit when 5 V is supplied to the power feed jack ⑥.
- ⑤Power supply cable grip ..... Safety grip to prevent disconnection of 5V power supply.
- ⑥Power feed jack ..... Jack for connecting power supply unit.  $\oplus$  —  $\ominus$   
Use a plug with specifications as shown below.
- ⑦Terminal block cover mounting screws ..... ( M3 ( 0.12 ) )
- ⑧Terminal block for RS-422/485 ..... Used in connection 485PC-IF and PC.  
( M3 ( 0.12 ) )  
For detail of connection see section 3.6

### 2.5.2 Power feed plug specifications

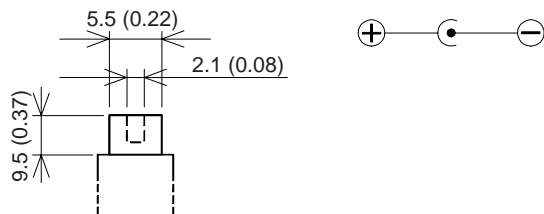

<b>1</b>	<b>Outline and system configuration</b>
<b>2</b>	<b>Specification</b>
<b>3</b>	<b>Settings and produres before operation</b>
<b>4</b>	<b>Communication using dedicated protocols</b>
<b>5</b>	<b>Commands</b>
<b>6</b>	<b>Diagnostics</b>
	<b>Appendix A</b>



## 3. Settings and procedures before operation

This chapter only explains the settings and procedures for linking to an FX series PC (using 485PC-IF and 485ADP). For the A series PC, see the appropriate A series manual.

### 3.1 Procedures before operation

The flowchart below shows the necessary procedures to setup the computer link for use with the FX series PC.

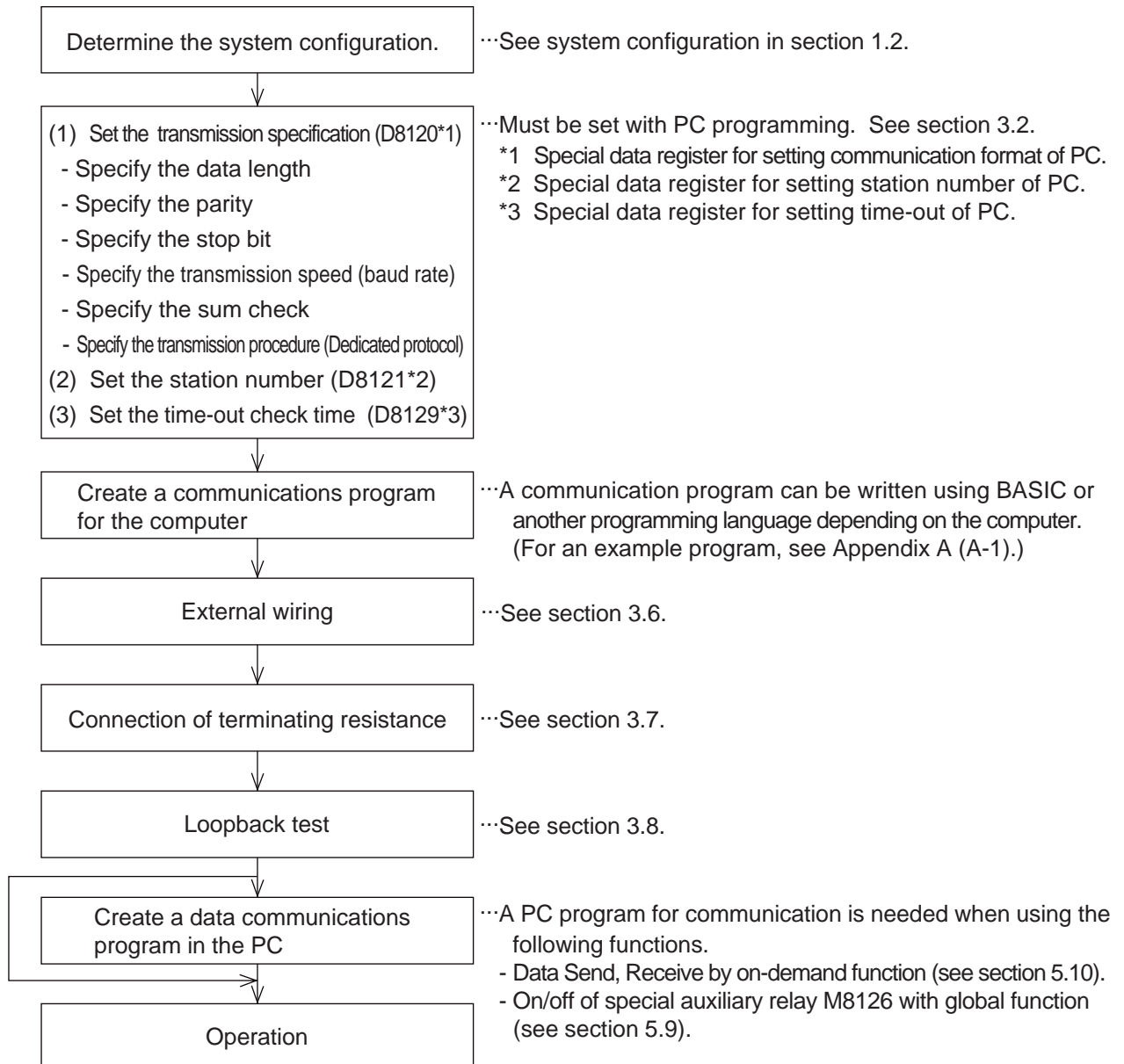

#### Notes

- (1) When using FX, FX2c series, special data registers D8120, D8121 and D8129 are battery backed.
- (2) When using the FX<sub>0N</sub> series PCs, turn on the special auxiliary relay M8120 to make special data registers D8120, D8121, and D8129 battery backed. When the special auxiliary relay M8120 is in an ON state, it must be noted that the backed up data registers D254, D255 become general data registers.
- (3) If D8120 or D8121 settings are changed, it is necessary to reset the power of the PC to initialize the new values.

## 3.2 Setting of transmission specifications and transmission control protocol

The transmission specifications and transmission control protocol are set with data register D8120 (abbreviated to special D8120) of the PC.

In the case of FX<sub>ON</sub> series, it is necessary to turn on M8120 when using special D8120.

When a setting is changed, turn off the power source of the PC once and then turn it on again.



### 3.2.1 Setting of transmission specifications

The transmission specification is set using b0 to b7 of special D8120. The setting data is as follows.

b 0	Data length	b0=0:7bit , b0=1:8bit
b 1	Parity	(b2,b1)=(0,0):No parity
b 2		(b2,b1)=(1,1):Odd parity
b 3	Stop bits	(b2,b1)=(0,1):Even parity
b 3	Stop bits	b3=0:1bit , b3=1:2bit
b 4	Transmission speed (baud rate)	(b7,b6,b5,b4)=(0,0,1,1): 300
b 5		(b7,b6,b5,b4)=(0,1,1,1): 4,800
b 6		(b7,b6,b5,b4)=(0,1,0,0): 600
b 7		(b7,b6,b5,b4)=(1,0,0,0): 9,600
b 6		(b7,b6,b5,b4)=(0,1,0,1): 1,200
b 7		(b7,b6,b5,b4)=(1,0,0,1):19,200
b 7		(b7,b6,b5,b4)=(0,1,1,0): 2,400

### 3.2.2 Setting of transmission control protocol

The transmission control protocol is set using b8 to b15 of special D8120. The setting data is as follows.

b8-b12	Not used	Set b8 to b12 = 0 (All set to 0)
b13	Sum check	b13=0: sum check code is not added.      b13=1: sum check code is added automatically.
b14	Protocol *	b14=0: Dedicated protocol is not used.      b14=1: Dedicated protocol is used.
b15	Transmission control protocol	b15=0: Dedicated protocol format 1 is used.      b15=1: Dedicated protocol format 4 is used.

\* When using 485PC-IF and 485ADP to communicate data using a dedicated protocol use b14=1.

### 3.3 Setting of station number

The station number is the number provided at the PC in order to determine which PC the computer accesses. In the FX series PC, the station number is set by the special data register D8121 (special D8121 hereinafter). The setting range is 00H to 0FH. In the case of FX<sub>0N</sub> series turn on M8120 when using the special D8121. For the setting method of an A series PC, see the A series manual.

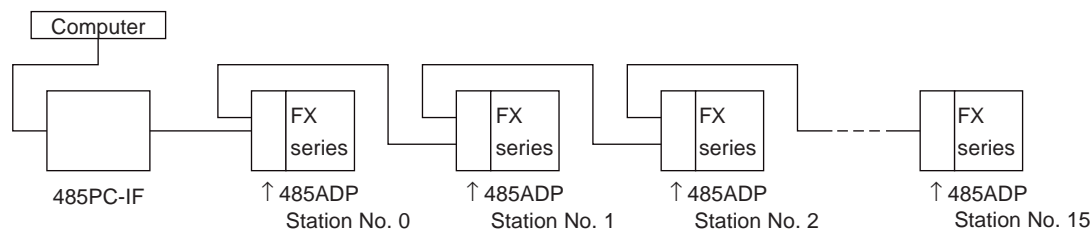

The following instructions can be used to set the station number of station 0 in the above system.

```

M8002
┌───┴───┐ ┌───┴───┐ [ MOV H0 D8121 ]

```



**Notes**

- (1) When setting station numbers, don't set the same number at more than 1 station. Otherwise, transmission data may become confused and communication irregular.
- (2) Station numbers need not be set in numerical order, but are free to be set within the specified range (00H to 0FH). For example, setting in a random order or skipping numbers is acceptable.

### 3.4 Setting of time-out check time

The time out check time refers to the duration after termination of Receive (final character received) of a failed transmission from the computer to the PC, until the Send sequence is initialized. This check time is specified as follows depending on the model and version of the PC.

To set the time-out check time as 60 ms:

```

M8002
┌───┴───┐ ┌───┴───┐ [ MOV K6 D8129 ]

```



**Other function information:**

- In the case of FX<sub>0N</sub> series, turn on M8120 when using the special D8129.

PC series	Setting range
FX <sub>0N</sub>	1 to 255 (10 to 2,550 ms); however, a setting of "0" gives 100 ms.
FX, FX2C	1 to 3, 276 (10 to 32,760 ms); however, setting of "0" gives 100 ms.

It must be noted that the time-out check time is not updated until the next character is received, and hence must be set to at least more than the time necessary to receive one character at the baud rate (transmission speed) in use. When 1 character = 12 bits, the minimum setting of time-out check time is as follows.

Baud rate (bps)	Time to receive one character (ms)	Time-out check time (set value)
300	40	50ms(5)
600	20	30ms(3)
1200	10	20ms(2)
2400	5	10ms(1)
4800	2.5	10ms(1)
9600	1.25	10ms(1)
19200	0.625	10ms(1)

## 3.5 Cautions for connection of 485PC-IF and power supply unit



### Caution !

- When a voltage exceeding the allowable range ( $5\text{ V} \pm 5\%$ ) is supplied to the 5 VDC power socket of 485PC-IF, internal circuitry may be damaged and/or communication data may become abnormal. Use an appropriate power supply unit conforming to the given specification.

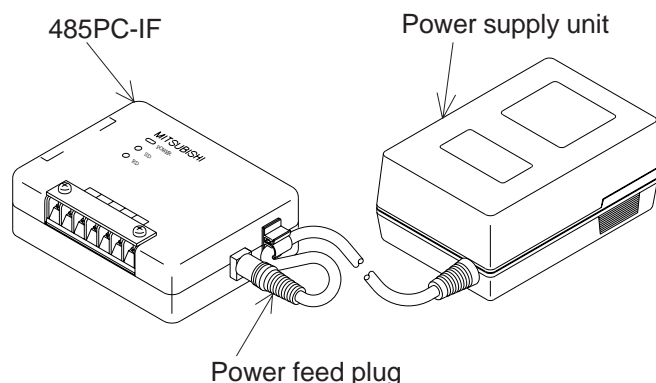

## 3.6 External wiring

### 3.6.1 Cautions for wiring

Noise-resistant external wiring is very important as one of the requirements for a system of high reliability and to make the best of the functions of the 485PC-IF and 485ADP. Cautions for external wiring are given below.



### Caution !

- (1) This system is designed to read and write data (forced on/off) while the PC is running. If abnormal data is written into the PC, due to effects of noise, the PC may malfunction and cause machine trouble or an accident. Therefore, observe the following cautions.
  - Do not lay signal cables near high voltage power cables or put them in the same trunking duct. Otherwise effects of noise or surge induction are likely to take place. Keep a safe distance of more than 100 mm from these wires.
  - Ground the shield wire or shield of a shielded cable at one point on the PC. Do not, however, ground at the same point as high voltage lines.
- (2) The terminal screws for the terminal block of the RS-485 are M3 screws and therefore the crimp style terminal (see drawing) suitable for use with these screws should be fitted to the cable for wiring.

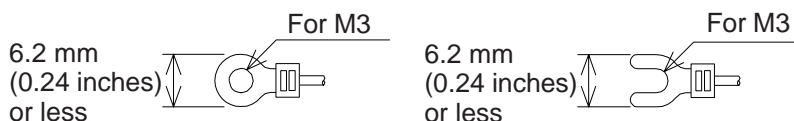

- (3) The terminal tightening torque is 0.5 to 0.8 N•m (5 to 8 kgf•cm), and tighten securely to avoid malfunction.
- (4) Cut off all phases of power source externally, before installation or wiring work in order to avoid electric shock or damage of product.
- (5) Replace the provided terminal cover before supplying power and operating the unit after installation or wiring work in order to avoid electric shock.

### 3.6.2 Connecting to a computer

Connect with a computer in the following manner.

- (1) Cautions for connection of RS-232C and computer  
 RS(RXD) and CS (CTS), and DR (DSR) and ER (DTR) are not used in the 485PC-IF.  
 (They are respectively short-circuited inside of the 485PC-IF.)

(2) Connection examples

485PC-IF		Cable connection and signal direction	Computer
Signal name	Pin No.		Signal name
SD(TXD)	2	→	FG *1
RD(RXD)	3		←
RS(RTS)	4	→	SD(TXD)
CS(CTS)	5		←
DR(DSR)	6	→	RS(RTS) *2
SG	7		←
ER(DTR)	20	→	DR(DSR) *2
			←
			CD *1
			ER(DTR) *2

\*1 This signal is not used.

\*2 This signal is not used, but since it is short-circuited inside the 485PC-IF, connect wiring depending on the need at the computer.

### 3.6.3 Connecting to a PC

For connection of the programmable controller, two-pair wiring and one-pair wiring are available, which are used as follows.

- Two-pair wiring is required when:

- 1) There is RS-422 device in the system configuration.
- 2) High speed response is required (using message wait within 70 ms; see section 4.4.3 (5)).
- 3) The on-demand function is used (possible, however, only when the system configuration is 1:1).
- 4) Adding to a system already using two-pair wiring.

- One-pair wiring is required when:

- 1) Adding to a system already using one-pair wiring.
- 2) The system configuration is standardized to RS-485 devices, and two-pair wiring is not necessary.

The connecting methods of two-pair wiring and one-pair wiring are explained in the following pages.

(1) Examples of two-pair wiring (for RS-422 circuit)

(a) When connecting one computer and one programmable controller

485PC-IF		Cable connection and signal direction	485ADP(PC)		Remarks
Signal name			Signal name		
SDA	R *1		RDA	Receive data	
SDB			RDB	Receive data	
RDA	R *1		SDA	Send data	
RDB			SDB	Send data	
SG			SG	Signal ground	
Grounding resistance of 100 Ω or less			FG	*2	Frame ground
			24V	*3	Power supply terminal
			24G	*3	Power supply terminal

(b) Computer and PCs in 1:n connection (n is max. 16 stations)

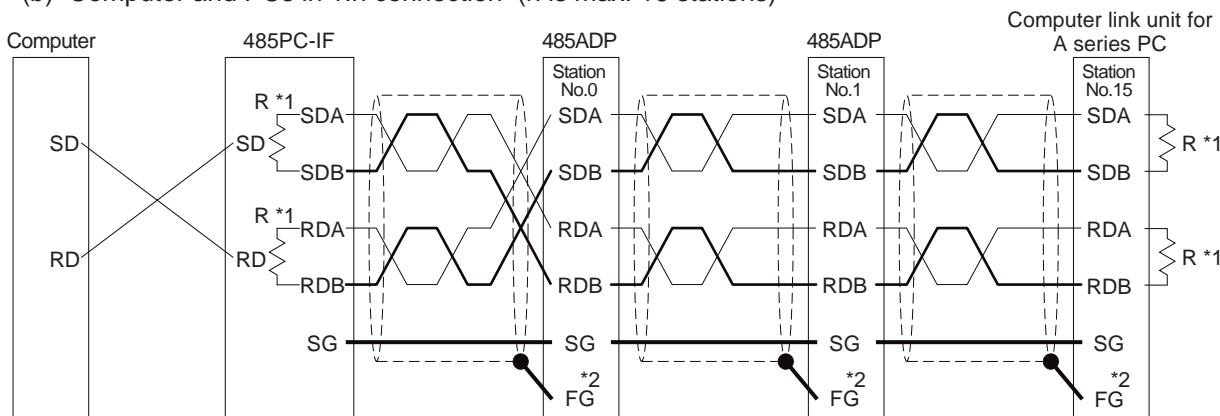

- \*1 R is terminating resistance. Connect the terminating resistance (330 Ω) between terminals SDA and SDB, and between RDA and RDB. For detail see section 3.7.
- \*2 Connect terminal FG to the earth terminal of the programmable controller main unit, grounded at a resistance of 100 Ω or less (class 3). For the computer link unit of the A series PC, see the manual of the computer link unit.
- \*3 For the DC 24 V power supply, the service power supply of the programmable controller main unit can be used.  
The terminal logout is different for the sake of explanation. For the 485PC-IF, see section 2.5, and for the 485ADP and computer link unit for A series PC, see the respective manuals.

(2) Examples of one-pair wiring (for RS-485 circuit)

(a) When connecting one computer and one programmable controller

485PC-IF		Cable connection and signal direction	485ADP(PC)		Remarks
Signal name			Signal name		
SDA	R *1		RDA	Receive data	
SDB			RDB	Receive data	
RDA			SDA	Send data	
RDB			SDB	Send data	
SG		SG	Signal ground		
Grounding resistance of 100 Ω or less		FX base unit	FG	*2	Frame ground
		DC24V	24V	*3	Power supply terminal
			24G	*3	Power supply terminal

(b) Computer and PCs in 1:n connection (n is max. 16 stations)

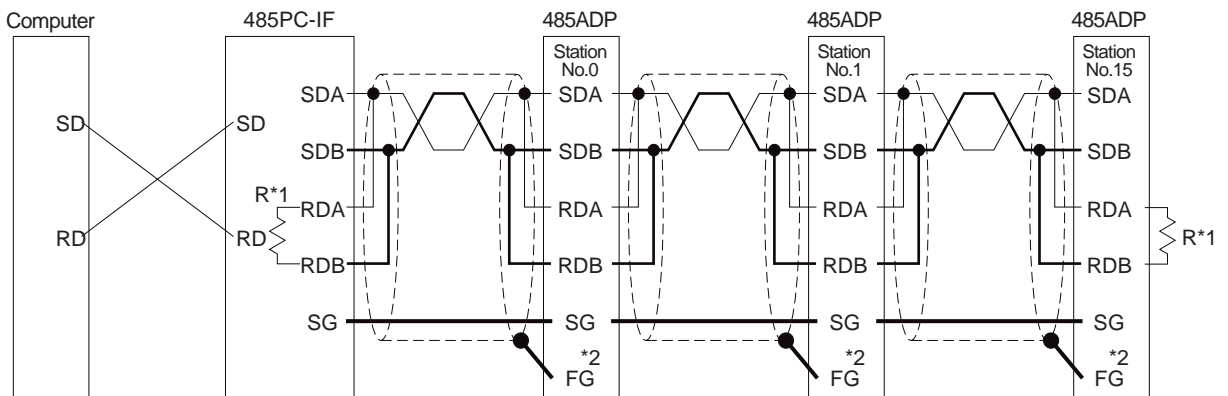

\*1 R is terminating resistance. Connect the terminating resistance (110 Ω) between terminals RDA and RDB. For detail see section 3.7

\*2 Connect terminal FG to the earth terminal of the programmable controller main unit, grounded at a resistance of 100 Ω or less (class 3). For the computer link unit of the A series PC, see the manual of the computer link unit.

\*3 For the DC 24 V power supply, the service power supply of the programmable controller main unit can be used.

The terminal logout is different for the sake of explanation. For the 485PC-IF, see section 2.5, and for the 485ADP and computer link unit for A series PC, see the respective manuals.

### 3.7 Connection of terminating resistance

The terminating resistance is the resistance connected between SDA and SDB, or RDA and RDB at both end stations of the circuit when connecting with an RS-485 or RS-422 circuit.

#### 3.7.1 Classification of terminating resistances

This product includes two sets of terminating resistances (330 Ω x 2, 110 Ω x 1), and depending on the circuit being used, the terminating resistance to be connected is as follows.

- When communicating by RS-422 circuit, resistance of 330 Ω, 1/4W.
- When communicating by RS-485 circuit, resistance of 110 Ω, 1/2W.

How to distinguish the terminating resistances



#### 3.7.2 When connecting computer and PC by 1:1

For A series PC connections, see the A series PC manual.

System configuration		<p>*1 Connection example</p> <div style="display: flex; justify-content: space-around;"> <div style="text-align: center;"> <p>(Two-pair wiring)</p> </div> <div style="text-align: center;"> <p>(One-pair wiring)</p> </div> </div>
Objective station	Connecting method of terminating resistance	
① , ②	Connect the terminating resistance to each unit between terminals SDA and SDB, and terminals RDA and RDB.	

\*2 Use 485ADP with FX series PCs, and A series computer link unit with A series PCs.

#### 3.7.3 When connecting computer and PCs by 1:n

For the A series PC, see the A series PC manual.

System configuration		<p>*1 Connection example</p> <div style="display: flex; justify-content: space-around;"> <div style="text-align: center;"> <p>(Two-pair wiring)</p> </div> <div style="text-align: center;"> <p>(One-pair wiring)</p> </div> </div>
Objective station	Connecting method of terminating resistance	
① , ③	Connect the terminating resistance to each unit between terminals RDA and RDB.	
②	Terminating resistance is not needed.	

\*2 Use 485ADP with FX series PCs, and A series computer link unit with A series PCs.

## 3.8 Loopback test

The Loopback test is the function for checking the wiring and communication format by confirming the communication function of the computer and the PC using the command (TT) of the dedicated protocol, format 1 or 4.

Operate the Loopback test by following steps 1 to 5. For operating procedures of the A series PC, see the A series PC manual.

(Step 1) Connection of computer and PC

Connect the computer and PC correctly according to section 3.6.

(Step 2) Setting of transmission specifications, transmission procedure, and station number.

Set the transmission specifications and transmission procedure in special data register D8120 of the PC, and set the station number in the PC program with special data register D8121.

(For setting method, see section 3.2.)

(Step 3) Starting of PC

Using the run/stop switch or run terminal of the PC, switch the PC to run, and turn on the power source. If special D8120 and D8121 are to be set from a peripheral device (i.e. not by the PC program) it is only necessary to turn on the power source.

(Step 4) Execution of command for Loopback test

1. Create the Loopback test program on the computer, and send the command and data to the PC. (For message composition of format 1 or 4, see section 4.4.1 and 4.4.2; for details of Loopback command (TT), see section 5.11.)
2. The PC transmits the received data directly to the computer.

(Step 5) Computer coincidence check

1. Check at the computer if data transmitted from the computer to the PC is identical with the data transmitted back from the PC to the computer. Identical data indicates that communication between the computer and the PC is normal. If the data transmitted are not identical, the transmission specifications settings probably do not match. See troubleshooting in chapter 6.
2. If communication is not possible, the cable connection or transmission specification is probably incorrect. Correct according to the troubleshooting hints in chapter 6, and repeat the Loopback test.
3. After a successful Loopback test, the computer can be linked using the dedicated protocol.

## 3.9 Operation, maintenance and checking

### 3.9.1 Operation



Caution !

- Before using remote run/stop, data write (bit unit, word unit), and before execution of the computer program, read the manual carefully, and confirm safe operation. Faulty handling or programming error may cause machine trouble or accident.

### 3.9.2 Maintenance, checking

Check the following two points for 485PC-IF, and service according to the items mentioned in the FX PC manual in order to use the system at its best.

- (1) Make sure terminals are tightened securely.
- (2) Make sure the connection between 485PC-IF and power supply unit is correct.



<b>1</b>	<b>Outline and system configuration</b>
<b>2</b>	<b>Specification</b>
<b>3</b>	<b>Settings and produres before operation</b>
<b>4</b>	<b>Communication using dedicated protocols</b>
<b>5</b>	<b>Commands</b>
<b>6</b>	<b>Diagnostics</b>
	<b>Appendix A</b>



# 4. Communication using dedicated protocols

This chapter explains the details and methods of specifying dedicated protocol used for linking of the FX PC and computer. The dedicated protocol is available in two types, format 1 and format 4 (the format names conform to the dedicated protocols used in the computer link unit of the A series PC).

## 4.1 Data flow by link

Shown below are drawings of data flow for reading, writing, and status control of the PC CPU.

(1) The computer reads data from the PC CPU.

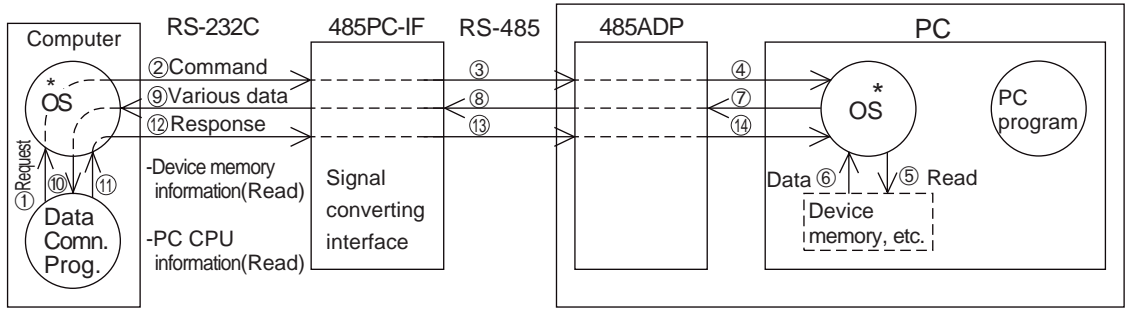

(2) The computer sends data to the PC CPU.

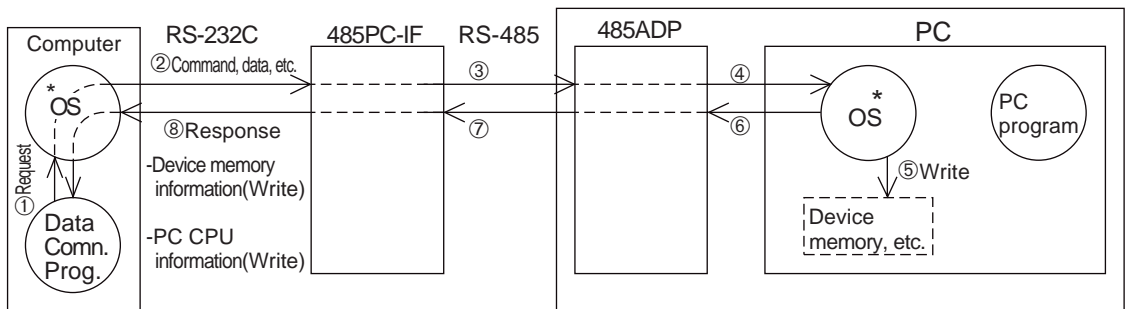

(3) The PC CPU sends data to the computer.

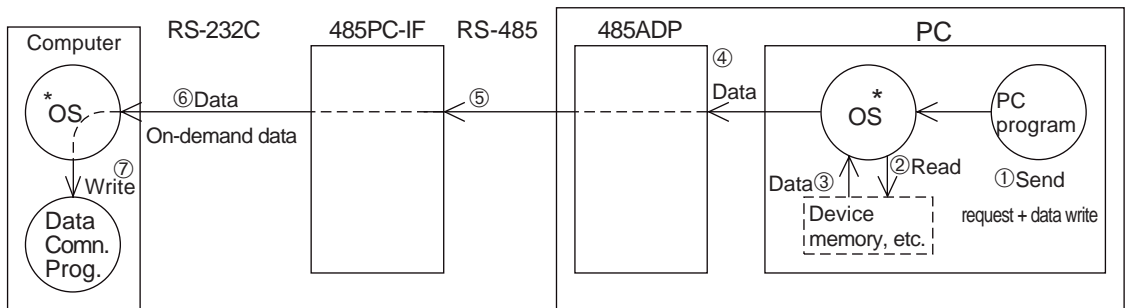

\* OS (operating system) is the software for operating (or using) effectively the resources such as the CPU, memory, terminal, file and network.

## 4.2 Information needed before programming

### 4.2.1 PC operation during data communication

The operation and scan time of PC by the computer link are as follows.

While the PC is running, access requests to the PC from the computer are processed one every END processing. The processing of Send or Receive data is performed using interrupts.

Therefore, during the processing of Send or Receive, the scan time is extended; typically by about 10 percent. The scan time can be monitored using the special data registers D8010 to D8012 of the PC.

### 4.2.2 Precautions during data communication

#### 1) Conditions under which the transmission sequence is initialised

The transmission sequence of the PC is initialised during the following conditions.

- When the power is turned on
- When data communication is completed normally
- When control code EOT or CL is received
- When a NAK control code is received
- After the time-out check time has elapsed (see section 3.4)

#### (2) Occurrence of framing error at the computer

When a commercial RS-485 interface is used at the computer, if nothing is transmitted from the PC to the computer at the interface, a framing error may occur at the computer.

Accordingly, read and skip the data at the computer until any one of STX, ACK, and NAK is transmitted from the PC.

#### (3) NAK response from PC

NAK response from the PC to the computer is done when an error is detected.

#### (4) Command transmission from computer

When sending a command from the computer to the PC using the dedicated protocol, only send the command after a gap of approximately two PC scans from the time the data communications required by the previous command are completed.

## 4.3 How to read a control protocol diagram

### (1) When the computer reads data from the PC (computer ← PC)

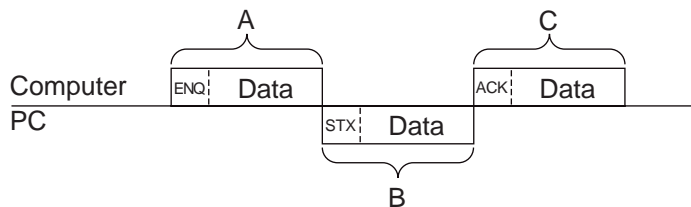

- 1) Areas A and C indicate transmission from the computer to the PC.
- 2) Area B denotes transmission from the PC to the computer.
- 3) The computer program is created so that the data is transmitted in the order read from left to right, and the protocol determines that the data is sent in the sequence A, B, C.  
(Example: In area A, ENQ is transmitted followed by all other data, starting to the right, after the ENQ.)

(2) When writing data from the computer into the PC (computer → PC)

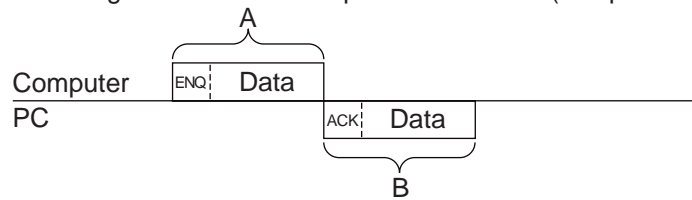

- 1) Area A indicates transmission from the computer to the PC.
  - 2) Area B denotes transmission from the PC to the computer.
  - 3) The computer program is created so that the data is transmitted in the order read from left to right, and the protocol determines that the data is sent in the sequence A, B.
- (Example: In area A, ENQ is transmitted followed by all other data, starting to the right, after the ENQ.)

## 4.4 Basic formats of dedicated protocol

There are two formats for the dedicated protocol; which may be selected by setting special data register D8120 (see section 3.2).

The difference between the two formats is whether CR + LF is added to each block or not.

The protocols are format 1 and format 4. (The format names conform to the computer link unit for A series PC.)



Basic format of transmitted data.

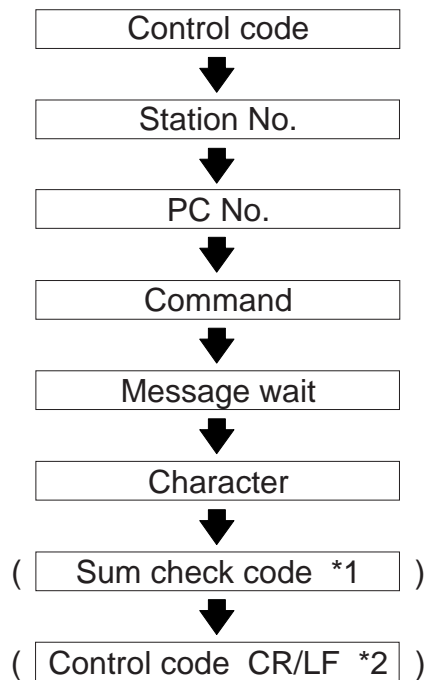

\*1 Whether or not to add sum check code can be selected using the communication format special data register D8120.

\*2 Whether or not to add terminating CR + LF codes is determined by the protocol selected.

4.4.1 Control protocol format 1

Description	Control protocol
<p>To read data from the PC to the computer</p>	
<p>To write data from the computer to the PC</p>	
<p>Remarks</p>	<p>(1) Sum check code is used when the sum check flag is set "Yes" ("b13=1" in special data register D8120), and not used when set to "NO" ("b13=0").</p> <p>(2) When the sum check flag is set to "Yes", the sum check is made on the characters in the asterisked area.</p> <p>(3) In the diagram, the contents of character area A, character area B, and character area C depend on the individual system, but do not differ depending on the format of control protocol.</p> <p>For details of each character area, see the link contents.</p>

4.4.2 Control protocol format 4

Description	Control protocol
<p>To read data from the PC to the computer</p>	<p>The diagram illustrates the transmission sequence for reading data from the PC to the computer. It shows two possible data structures. The first structure consists of: Station No. (N, A, K), PC No. (L, C, R, F), Command (E, N, Q), Message wait time, Character area A (marked with an asterisk), Sum check code (L, C, R, F), Station No. (S, T, X), PC No. (L, C, R, F), Character area B (E, T, X), Sum check code (L, C, R, F), Station No. (A, C, K), PC No. (L, C, R, F), and Error code (L, C, R, F). The second structure is identical but includes an Error code field (L, C, R, F) before the Station No. (S, T, X). Asterisks indicate that the sum check code is calculated over the Command, Message wait time, and Character area A fields.</p>
<p>To write data from the computer to the PC</p>	<p>The diagram illustrates the transmission sequence for writing data from the computer to the PC. It shows two possible data structures. The first structure consists of: Station No. (E, N, Q), PC No. (L, C, R, F), Command (E, N, Q), Message wait time, Character area C (marked with an asterisk), Sum check code (L, C, R, F), Station No. (A, C, K), PC No. (L, C, R, F), Error code (L, C, R, F), Station No. (S, T, X), PC No. (L, C, R, F), and Error code (L, C, R, F). The second structure is identical but includes an Error code field (L, C, R, F) before the Station No. (S, T, X). Asterisks indicate that the sum check code is calculated over the Command, Message wait time, and Character area C fields.</p>
<p>Remarks</p>	<ol style="list-style-type: none"> <li>(1) Sum check code is used when the sum check flag is set "Yes" ("b13=1" in special data register D8120), and not used when set to "NO" ("b13=0").</li> <li>(2) When the sum check flag is set to "Yes", the sum check is made on the characters in the asterisked area.</li> <li>(3) In the diagram, the contents of character area A, character area B, and character area C depend on the individual system, but do not differ depending on the format of control protocol. For details of each character area, see the link contents.</li> </ol>

### 4.4.3 Control Protocol parts explained

This is to explain the content of data set in each control procedure.

(1) Control codes

The control codes are listed below.

Signal	Code (Hexadecimal)	Description	Signal	Code (Hexadecimal)	Description
STX	02H	Start of Text	LF	0AH	Line Feed
ETX	03H	End of Text	CL	0CH	Clear
EOT	04H	End of Transmission	CR	0DH	Carriage Return
ENQ	05H	Enquiry	NAK	15H	Not Acknowledge
ACK	06H	Acknowledge			

- (a) The PC initializes the transmission sequence when receiving any one of ENQ, ACK,NAK, and starts .
- (b) When EOT, or CL code is received as follows, the PC initializes the transmission sequence. At this time, no response is made from the PC.

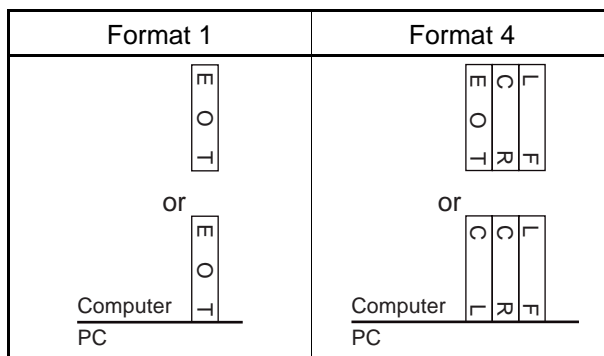

(2) Station number

The station number is the number identifying the PC that the computer accesses. At the PC, the number is set from 0 to 15 (00H to 0FH) in special data register D8121. In a message the number is represented as two ASCII characters; i.e. "00" to "0F" hexadecimal. When using the global function, however, the station number in the message should be "FF".

<Example>

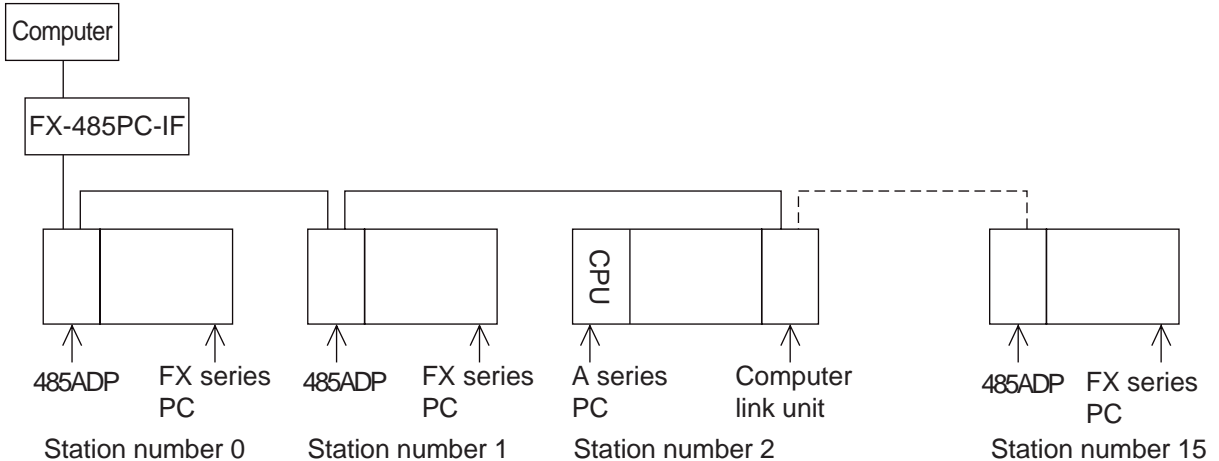

- (3) PC number  
 The PC number is the number identifying the PC CPU on the A series MELSECNET(II) or MELSECNET/B. Accordingly, the PC number for an FX series PC is FFH, and is represented as two ASCII characters; i.e. "FF". When using the on-demand function the PC number is automatically converted to FFH by the PC.  
 For the PC number of PC CPU on the MELSECNET (II), MELSECNET/B see the computer link manual for A series PCs.
- (4) Command  
 Used to specify the operation required, e.g. read, write, etc. Commands are defined using two ASCII characters.  
 For a description of the available commands, see section 4.7.1.
- (5) Message wait  
 This is a delay time required by some computers to switch between send and receive states. The message wait time determines the minimum delay before the PC sends data after receiving a message from the computer. Set the wait time according to the computer specifications.  
 The message wait time may be set between 0 to 150 ms in 10 ms increments. The value is set using a single ASCII character ("0" to "F") representing 0H to FH (0 to 15).  
 When using the 485PC-IF in a 1:n system always set the message to be 50 ms or longer (5 or more).

Example: Setting the message wait time

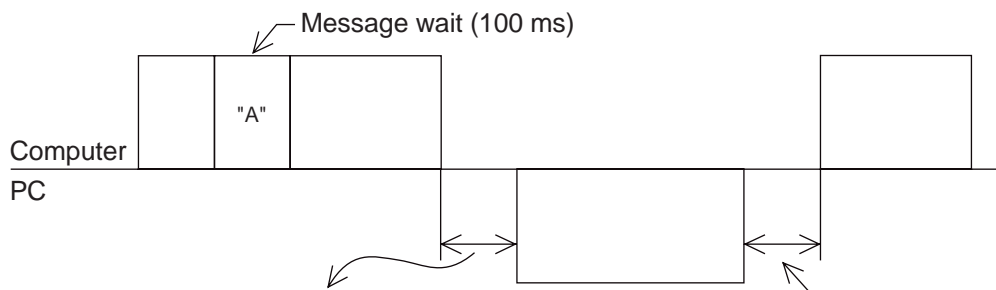

Transmission starts more than 100 ms later. Wait time must be longer than two-scan time.

- (6) Sum check code  
 The sum check code is used to verify that the data in a message has not been corrupted. It is calculated by adding (summing) the hexadecimal values of the ASCII character codes in the sum check area of a message. The lower two digits (in hexadecimal) of the summed result (the sum check code) are then represented as two ASCII characters at the end of the message. (Note: The sum of the decimal ASCII character codes, converted to hexadecimal, will give the same result).  
 Special data register D8120 (communication format) b13, sets whether or not to add the sum check code to the message.

- When "b13=1", the sum check code is automatically added to messages when transmitting, and a new sum check value is calculated from the Receive data and compared with the received sum check value, thereby checking the Receive message.
  - When "b13=0", the sum check code is not added, and the Receive data is not checked.
- An example showing how to calculate the sum check code is given below.

Example: When transmitting station number 0, PC number FF, command BR (device memory batch read), message wait time 30 ms, and data ABCD in format 1, the sum check code is calculated as follows.

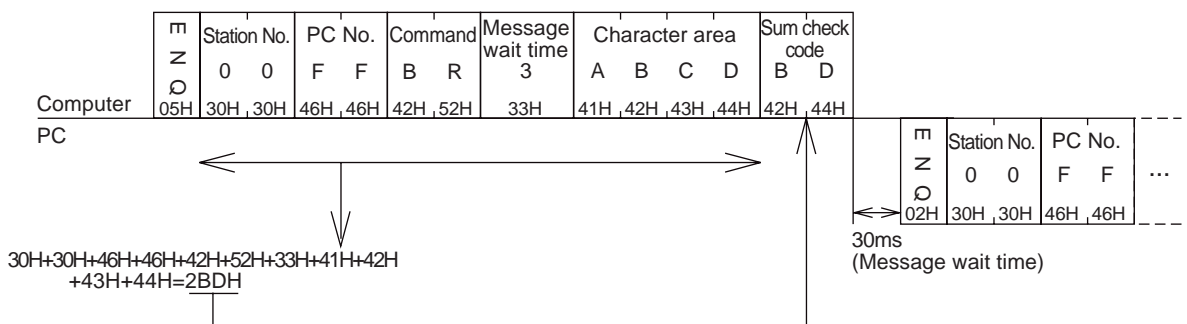

4.4.4 Error code

The error code is sent following a NAK response to indicate the type of error that occurred. It is transmitted as two ASCII characters representing the hexadecimal codes ranging from 00H to FFH. If two or more errors occur simultaneously, the error code with the lowest number is transmitted.

List of error codes

Error code (hexadecimal)	Error Description
00H,01H	
02H	Sum error
03H	Protocol error (the communication protocol does not conform to the format selected with D8120)
04H,05H	
06H	Character area error (the character area is incorrectly defined, or the specified command is not available)
07H~09H	
10H	PC number error (the PC number is not set to "FF" or not available from this station)
11H~17H	
18H	Remote error (remote run/stop is disabled)

With the FX series PC, the following errors are not transmitted using a NAK, but instead are shown at the PC by switching on special auxiliary relay M8063, and storing the error code in special data register D8063.

List of PC error codes

Error code (in D8063)	Error description
6301	Parity, overrun, framing error
6305	Command failure receiving a command other than GW (global) when the station number is "FF"
6306	Monitor timer over (message to be received is insufficient)

Because these errors are not transmitted it must be programmed at the computer so as to recognize an error by using a watchdog timer or other monitor timer.



Notes

- In the event of an error, the basic format of the control protocol is as shown below.

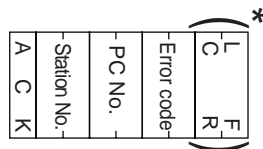

\* Depending on the type of protocol, it can be selected whether or not to add the content in parentheses.

## 4.5 Communication Timing chart

### 4.5.1 When reading data from the PC to the computer (with the message wait time set)

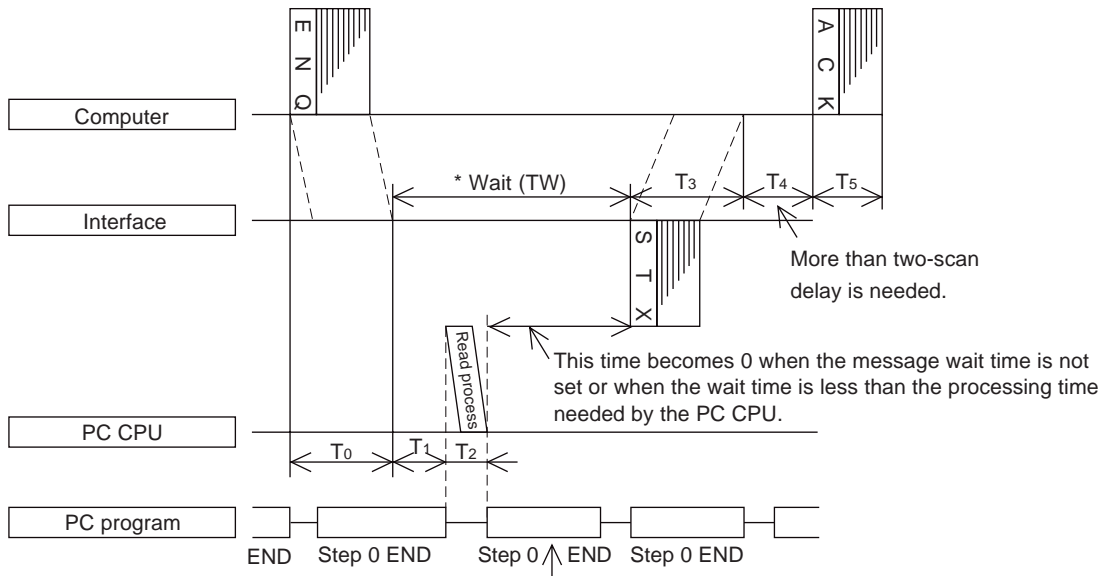

If the wait time has expired the response is sent at completion of the END process, otherwise the wait time is checked again during the next END process.

### 4.5.2 When writing data from the computer to the PC (with the message wait time set)

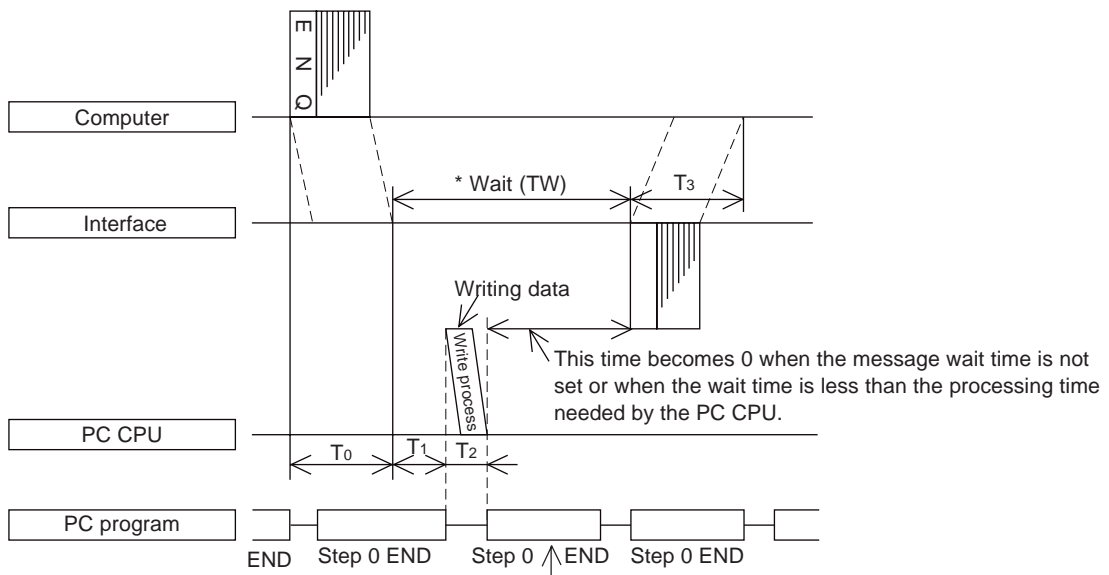

If the wait time has expired the response is sent at completion of the END process, otherwise the wait time is checked again during the next END process.

4.5.3 Communication Time

This is to explain the method of calculating the approximate time until all communication is over.

For the locations of T0 to T4, see the previous page.

(1) When reading data from the PC CPU to the computer

Communication time = T0 + (T1+T2 or TW, whichever is longer) + T3 + T4 + T5

T0, T3, T5 = 1/baud rate x number of bits in 1 character (1+7(8)+0(1)+1(2)) x number of characters

T1 = max. 1 scan time (during RUN, message processing is done at END processing, a maximum delay of 1 scan could occur depending on message timing; during STOP, T1 is 1 ms)

T2 = END process time of PC CPU during data communication

T4 = A delay of at least 2 scans is required

TW = set time when message wait is set

(2) When writing data from the computer to the PC CPU

Communication time = T0 + (T1+T2 or TW, whichever is longer) + T3

T0, T3 = 1/baud rate x number of bits in 1 character (1+7(8)+0(1)+1(2)) x number of characters

T1 = max. 1 scan time (during RUN, message processing is done at END processing, a maximum delay of 1 scan could occur depending on message timing; during STOP, T1 is 1 ms)

T2 = END process time of PC CPU during data communication

TW = set time when message wait is set



### 4.6.2 When reading or writing word device memory

When handling word device memory, each word is expressed as 4 hexadecimal digits (each of 4 bits) starting with the higher digit. Each digit being represented by the appropriate ASCII character.

Example 1) When showing the contents of data registers D350, D351

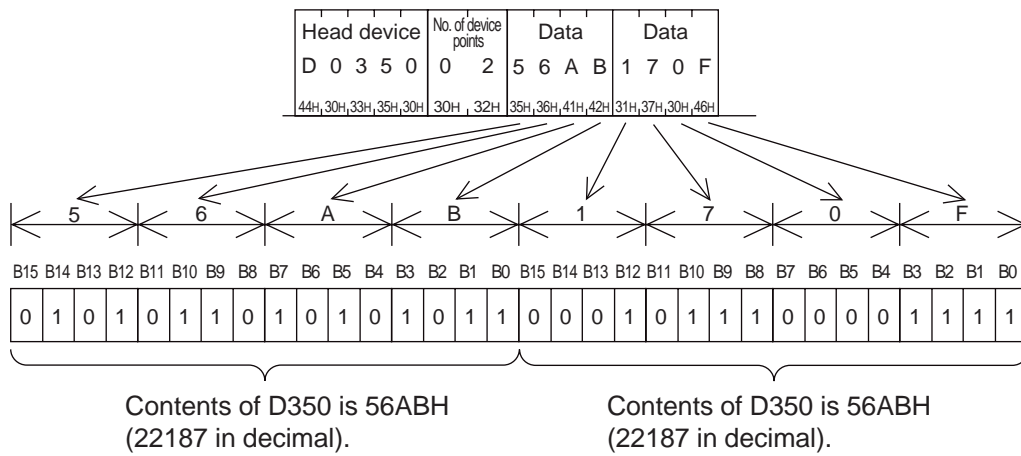

Example 2) When showing the contents of C200\* (32-bit counter)

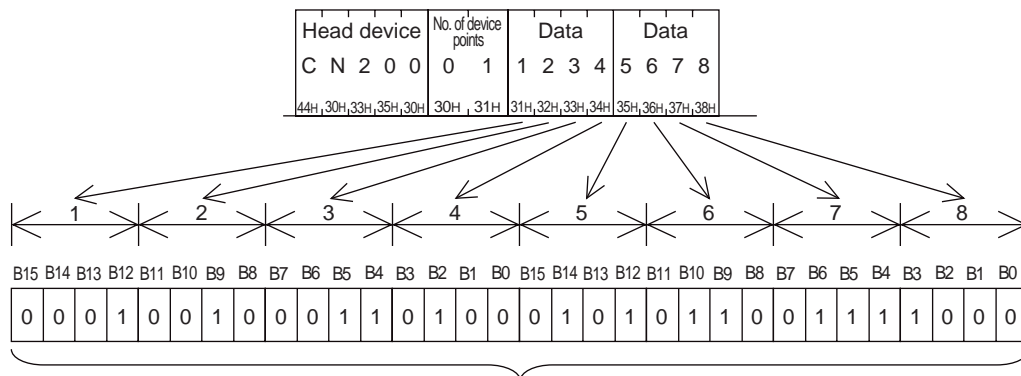

The content of the C200 shows 12345678H (305419896 in decimal notation).

\* The device code of C200 is CN200.

## 4.7 Commands and Device ranges

### 4.7.1 Commands

			Command		Description	Maximum No. of units per communication	
			Symbol	ASCII code		FX0N	FX,FX2C
Device memory	Batch read	Bit units	BR	42H,52	Reads a group of bit devices (X, Y, M, S, T, C), result is in units of 1 device.	54 points	256 points
		Word units	W	57H,52	Reads a group of bit devices (X, Y, M, S), result is in units of 16 devices. Reads a group of word devices (D, T, C), result is in units of 1 device.	13 words, 208 points	32 words, 512 points
	Batch write	Bit units	B	42H,57	Writes a group of bit devices (X, Y, M, S, T, C), data is in units of 1 device.	46 points	160 points
		Word units	W	57H,57	Writes a group of bit devices (X, Y, M, S), data is in units of 16 devices. Writes a group of word devices (D, T, C), data is in units of 1 device.	10 words, 160 points	10 words, 160 points
	Test (selective write)	Bit units	BT	42H,54	Set/reset individual bit devices (X, Y, M, S, T, C) selectively in units of 1 device.	10 points	20 points
		Word units	W	57H,54	Set/reset bit devices (X, Y, M, S) selectively in units of 16 devices. Write word devices (D, T, C*) selectively in units of 1 device.	6 words, 96 points	10 words, 160 points
	PC	Remote run	R	52H,52	Remote run/stop request to PC	---	---
		Remote stop	RS	52H,53			
		PC type read	PC	50H,43			
Global		G	47H,57	Set/reset the global flag (M8126 for FX series) to all connected PCs.	1 points	1 points	
On-demand		---		Send request from PC. Possible, however, only in 1:1 system configuration.	Maximum 13 words	Maximum 64 words	
Loopback test		TT	54H,54	Characters received from the computer are directly sent back to the computer.	25 characters	254 characters	

\* Counter except high speed (32-bit) counters C200 to C255.

### 4.7.2 Device specification ranges

The following is the device and device number range that can be used in the access of device memory. Each device is composed of five characters.

Device (1 character, 2 characters with timer and counter) + device number (4 characters, 2 characters with timer and counter) = 5 characters

#### (1) Bit devices

Device	Device specification characters		Decimal/octal expression	Usable command	
	FX0N	FX,FX2C		BR,BW,BT	WR,WW,WT
Inputs (X)	X0000~X017	X0000~X037	Octal		
Outputs (Y)	Y0000~Y017	Y0000~Y037			
Auxiliary relays (M)	M0000~M051	M0000~M153	Decimal	○	○
States (S)	S0000~S012	S0000~S099			
Special auxiliary relays (M)	M8000~M825	M8000~M825			
Timer contacts (T)	TS000~TS06	TS000~TS25			
Counter contacts (C)	CS000~CS03 CS235~CS25	CS000~CS25			×

In FX series, the timer coil (TC) and counter coil (CC) are not supported.

#### (2) Word devices

Device	Device specification characters		Decimal/octal expression	Usable command		
	FX0N	FX,FX2C		BR,BW,BT	WR,WW	WT
Timer current value (T)	TN000~TN06	TN000~TN25	Decimal	×	○	○
Counter current value (C)	CN000~CN03 CN235~CN25	CN000~CN25				○*
Data registers (D)	D0000~D025	D0000~D099				
File registers (D)	D1000~D249	D1000~D299				○
RAM file registers (D)	———	D6000~D799				
Special data registers (D)	D8000~D825	D8000~D825				

\*Only CN000 to CN199 can be used.

(C200 to C255 of 32 bit counter or high speed counter cannot be used.)



#### Notes

- When using bit devices specified in word units (WR, WW, WT), the number of the head device must be a multiple of 8 (or if an octal device end in 0) e.g. X30, M24.
- The special auxiliary relays (M8000 to M8255) and special data registers (D8000 to D8255) can be read only, write only, and reserved for system use.  
If an attempt is made to write outside the write enable range, an error may occur in the PC. Accordingly, for details of special auxiliary relays and special data registers, see the PC manual.

<b>1</b>	<b>Outline and system configuration</b>
<b>2</b>	<b>Specification</b>
<b>3</b>	<b>Settings and produres before operation</b>
<b>4</b>	<b>Communication using dedicated protocols</b>
<b>5</b>	<b>Commands</b>
<b>6</b>	<b>Diagnostics</b>
	<b>Appendix A</b>



## 5. Commands

This chapter describes the structure and gives examples for each command of the dedicated protocol. See also Chapter 4 "Communication using Dedicated Protocols"

The reference pages for each command are given below.

Command	Description	Section
BR	Bit devices read in units of 1 point.	5.1
WR	Bit devices read in units of 16 points, or word devices read in units of 1 point.	5.2
BW	Bit devices written in units of 1 point.	5.3
WW	Bit devices written in units of 16 points, or word devices written in units of 1 point.	5.4
BT	Bit devices specified in units of 1 point, and set/reset (forced on/off).	5.5
WT	Bit devices specified in units of 16 points, and set/reset (forced on/off), or word devices specified in units of 1 point, and data written.	5.6
RR	PC is started (RUN) by remote control.	5.7
RS	PC is stopped (STOP) by remote control.	5.7
PC	PC type name code is read.	5.8
GW	Global signal is turned on/off on all linked PCs.	5.9
—	On-demand function (Send request is issued from the PC. There is no command).	5.10
TT	Characters received from the computer are directly returned to the computer.	5.11

## 5.1 Batch read of device memory, bit units (BR command)

**Command Specification**

Protocol format 1 is shown.

Batch read command (bits)

Character area A

Computer PC

ENQ Station No. PC No. BR Message wait time Head device (5 characters) Number of devices (2 characters, hexadecimal) Sum check code

“0” (30H) indicates OFF.  
“1” (31H) indicates ON.

ACK Station No. PC No.

Character area B

STX Station No. PC No. Data of the specified devices ETX Sum check code

Specifies the range of devices to be read.

Notes

- Specify the range and number of devices so as to satisfy the following conditions.
  - 1 ≤ number of devices ≤ 256 (54 for FX0N) (256 points are specified by 00H)
  - Head device No. + number of devices - 1 ≤ max. device No.
- The station number, PC number, number of devices, and sum check code are expressed in hexadecimal.

**Command Example**

To read five points of data from X040 to X044 at PC station No. 5 (with message wait time set to 100 ms).  
(Assuming that X040 and X043 are OFF and X41, X42 and X44 are ON)

Computer PC

ENQ 05 FF BR AX0040 0547

The sum check is calculated over this range

STX 05 FF 01101 ETX 05

The sum check is calculated over this range

ACK 05 FF

Indicating X044 is ON  
Indicating X043 is OFF  
Indicating X042 is ON  
Indicating X041 is ON  
Indicating X040 is OFF

Notes

- Message wait time can be specified from 0 to 150 ms in 10 ms increments, expressed by 0H to FH (in hexadecimal). Therefore, 100 ms is expressed as “A”.

## 5.2 Batch read of device memory, word units (WR command)

### Command Specification

Protocol format 1 is shown.

Batch read command (words)

E	N	O	-	Station No.	-	PC No.	-	W	R	-	Message wait time
---	---	---	---	-------------	---	--------	---	---	---	---	-------------------

Character area A

H	e	a	d	d	e	v	i	c	e
Head device (5 characters)									
N	u	m	b	e	r	o	f	d	e
Number of devices (2 characters, hexadecimal)									
S	u	m	c	h	e	c	o	d	e
Sum check code									

Specifies the range of devices to be read.

Character area B

S	T	X	-	Station No.	-	PC No.	-	D	a	t	a	o	f	t	h	e	s	p	e	c	i	f	i	e	d	d	e	v	i	c	e	s
Data of the specified devices																																
E	T	X	-	Sum check code																												
Sum check code																																

One word device requires four hexadecimal digits. Therefore, one word is expressed using four characters.

A	C	K	-	Station No.	-	PC No.
A C K 0 5 F F						

A	C	K	-	Station No.	-	PC No.
A C K 0 5 F F						

### Notes

(1) Specify the range and number of devices (16 bit words) so as to satisfy the following conditions.

- $1 \leq \text{number of devices} \leq 64$  (32 words in the case of bit devices) (13 words for FX<sub>ON</sub>)
- Head device No. + number of devices (number of devices x 16 in the case of bit devices) - 1  $\leq$  max. device No.
- When reading 32-bit devices (C200 to C255), the returned data is a double word. Hence, the maximum number of devices is 32.

(2) The station number, PC number, number of devices, and sum check code are expressed in hexadecimal.

### Command Examples

[Example 1] To read 32 points of data from X040 to X077 at PC station No. 5 (with message wait time set to 0 ms).

Computer

E	N	O	-	0	5	-	F	F	-	W	R	-	0	X	0	0	4	0	-	0	2	-	4	8
05H 30H,35H 46H,46H 57H,52H 30H 58H,30H,30H,34H,30H 30H 32H 34H,38H																								

PC

The sum check is calculated over this range

S	T	X	-	0	5	-	F	F	-	1	2	3	4	-	A	B	C	D	-	E	T	X	-	C	8
02H 30H,35H 46H,46H 31H,32H,33H,34H 41H,42H,43H,44H 03H 43H,38H																									

The sum check is calculated over this range

The sum check is calculated over this range

A	C	K	-	0	5	-	F	F
06H 30H,35H 46H,46H								

1	2	3	4	A	B	C	D
0 0 0 1 0 0 1 1 0 0 1 1 0 1 0 0 1 0 1 1 1 0 1 1 1 1 0 0 1 1 0 1							
X X X X X X X X X X X X X X X X X X X X							
0 0 0 0 0 0 0 0 0 0 0 0 0 0 0 0 0 0							
5 5 5 4 4 4 4 7 7 7 7 6 6 6 6 6 6 6 6							
7 2 1 0 7 3 2 1 0 7 2 1 0 7 3 2 1 0 7 3 2 1 0							

### Notes

- Command WR uses word units. When reading 32 points, the number of devices is specified by "02" (16 points (bits) per one word unit).

[Example 2] To read the present value of two points, T123 and T124, at PC station No. 5.

Computer

E	N	O	-	0	5	-	F	F	-	W	R	-	0	T	N	1	2	3	-	0	2	-	6	4
05H 30H,35H 46H,46H 57H,52H 30H 54H,4Eh,31H,32H,33H 30H 32H 36H,34H																								

PC

The sum check is calculated over this range

S	T	X	-	0	5	-	F	F	-	7	B	C	9	-	1	2	3	4	-	E	T	X	-	C	8
02H 30H,35H 46H,46H 37H,42H,43H,39H 31H,32H,33H,34H 03H 42H,33H																									

The sum check is calculated over this range.

The sum check is calculated over this range

A	C	K	-	0	5	-	F	F
06H 30H,35H 46H,46H								

Present value of T123: 7BC9H (hexadecimal): indicates 31689 in decimal.  
 Present value of T124: 1234H (hexadecimal): indicates 4660 in decimal.

5-3

### 5.3 Batch write of device memory, bit units (BW command)

**Command Specification**

Protocol format 1 is shown

Computer  
PC

ENQ  
Station No.  
PC No.  
B W  
Message wait time  
Head device (5 characters)  
Number of devices (2 characters, hexadecimal)  
Data of the specified devices  
Sum check code

Specifies the range of devices to be written

"0" (30H) indicates OFF  
"1" (31H) indicates ON

S T X  
Station No.  
PC No.

**Notes**

(1) Specify the range and number of devices so as to satisfy the following conditions.

- $1 \leq \text{number of devices} \leq 160$
- Head device No. + number of devices -  $1 \leq \text{max. device No.}$

(2) The station number, PC number, number of devices, and sum check code are expressed in hexadecimal.

**Command Example**

To write data into five points from M903 to M907 at PC station No. 0 (with message wait time set to 0 ms).

Computer  
PC

ENQ  
Station No.  
PC No.  
B W  
Message wait time  
Head device (5 characters)  
Number of devices (2 characters, hexadecimal)  
Data of the specified devices  
Sum check code

The sum check is calculated over this range

Specifies to turn OFF M903  
Specifies to turn ON M904  
Specifies to turn ON M905  
Specifies to turn OFF M906  
Specifies to turn ON M907

A C K  
Station No.  
PC No.

### 5.4 Batch write of device memory, word units (WW command)

**Command Specification**

Protocol format 1 is shown

Computer  
PC

ENQ  
Station No.  
PC No.  
BR  
Message wait time  
Head device (5 characters)  
Number of devices (2 characters, hexadecimal)  
Data of the specified devices  
Sum check code

Character area C

Specifies the range of devices to be read.  
One word device requires four hexadecimal digits.  
Therefore, one word is expressed using four characters.

STX  
Station No.  
PC No.

**Notes**

- Specify the range and number of devices (16 bit words) so as to satisfy the following conditions.
  - $1 \leq \text{number of devices} \leq 64$  (10 words in the case of bit devices)
  - Head device No. + number of devices (number of devices x 16 in the case of bit device) -  $1 \leq \text{max. device No.}$
- The station number, PC number, number of devices, and sum check code are expressed in hexadecimal.

**Specification Examples**

[Example 1] To write to 32 points from M640 to M671 at PC station No. 0 (with message wait time set to 0 ms).

Computer  
PC

ENQ 00FFWW0M0640022347AB9605

ACK 05FF

The sum check is calculated over this range

1 2 3 7 A B 9 6

0011100101110111011101110111011101110111011011101110

MMM 666 555 543

MMMMMM 666666 4444776 3210109

MMM 666 555 9876

**Notes**

- Command WW uses word units. When writing 32 points, the number of devices is specified by "02" (16 points (bits) per one word unit).

[Example 2] To write data to two points, D0 and D1, at PC station No. 0 (with message wait time set to 0 ms).

Computer  
PC

ENQ 00FFWW0D0000021234ACD7F9

ACK 05FF

The sum check is calculated over this range

1234H (hexadecimal) to D0: indicates to write 4660 in decimal.  
ACD7H (hexadecimal) to D1: indicates to write -21289 in decimal.

## 5.5 Test of device memory, bit unit (selective write) (BT command)

**Command Specification**

Protocol format 1 is shown

Test Command (selective write, bits) ← Character area C →

Computer	ENQ	Station No.	PC No.	BT	Message wait time	Number of devices (2 characters, hexadecimal)	Device (5 characters)	Set/reset (~)	Device (5 characters)	Set/reset	Sum check code	ACK	Station No.	PC No.
PC								1 character "0" (30H) indicates reset (OFF) "1" (31H) indicates set (ON)						

**Notes**

- Specify the range and number of devices so as to satisfy the following condition.
  - $1 \leq \text{number of devices} \leq 20$  (10 for FX<sub>ON</sub>)
- The station number, PC number, number of devices, and sum check code are expressed in hexadecimal.

**Specification example**

To set ON M50, OFF S100, and ON Y001 at PC station No. 5 (with message wait time set to 0 ms).

Computer	M	5	F	F	B	T	0	0	3	M	0	0	5	0	1	S	0	1	0	0	0	Y	0	0	0	1	1	E	C
PC	05H	30H,35H	46H,46H	42H,54H	30H	30H,33H	4DH,30H,30H	35H,30H	31H	53H,30H,31H	30H,30H	30H	59H,30H,30H	30H,30H,31H	31H	45H,43H	ACK	05	FF										

The sum check is calculated over this range

Set (ON)      Reset (OFF)      Set (ON)

### 5.6 Test of device memory, word units (selective write) (WT command)

**Command Specification**

Protocol format 1 is shown.

Computer  
PC

When specifying bit devices, specify the Head device.

One word device requires four hexadecimal digits. Therefore, one word is expressed using four characters.

**Notes**

- Specify the range and number of devices (16 bit words) so as to satisfy the following conditions.
  - 1 ≤ number of devices ≤ 10 (6 for FX<sub>0N</sub>) (one unit is 16 points for bit devices)
- The station number, PC number, number of devices, and sum check code are expressed in hexadecimal.
- C200 to C255 (CN200 to Cn255) which are 32-bit devices cannot be handled in this command.

**Specification example**

To changing the present value of D500 to 1234H, bits Y100 to Y117 to BCA9H, and the present value of C100 to 100 at PC station No. 5 (with message wait time set to 0 ms)

Computer  
PC

The sum check is calculated over this range

Indicates to change the contents of D500 to 1234H or 4660 in decimal.

Indicates to change the present value of C100 to 64H or 100 in decimal.

Each bit 0/1 indicates reset (OFF) or set (ON) respectively.

## 5.7 Remote run/stop with PC (RR, RS commands)

### 5.7.1 Operation of remote run/stop

When remote run/stop is requested from the computer, the PC forced run mode, and the special auxiliary relays M8035, M8036, M8037 are controlled as follows.

- Remote run

When remote run (RR command) is requested, M8035 and M8036 are set ON at the PC, and forced run mode becomes active; the PC switching to RUN.

However, when remote run is executed while the PC is running (forced or otherwise), the state is not changed, and the remote error code (18H) is returned to the computer.

- Remote stop

When remote stop (RS command) is requested, M8037 is set ON at the PC. This in turn resets M8035, M8036 and M8037 to OFF and forced run mode is disabled; the PC switching to STOP.

However, when remote stop is executed while the PC is not in forced run mode, the state is not changed, and the remote error code (18H) is returned to the computer.

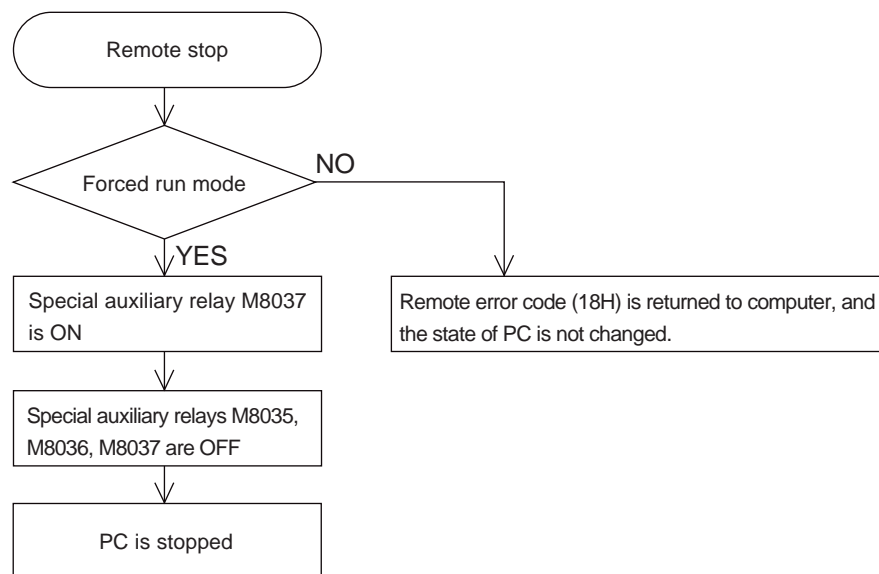

### 5.7.2 Conditions for valid execution of remote run/stop

The RUN terminal of the PC is OFF, any built-in run/stop switch is at STOP.

- Remote run

The PC should be stopped.

- Remote stop

The PC should be in forced run mode.



#### Notes

- Forced run mode is not restored after a power failure. When the PC is in forced run mode, if the power source is turned off and on, the special auxiliary relays M8035, M8036, M8037 are all reset to OFF, and the PC remains in STOP.

5.7.3 Control specification and examples of remote run/stop

**Control specification**

Protocol format 1 is shown.

PC remote run command: "RR"  
PC remote stop command: "RS"

Computer	PC	ENQ	Station No.	PC No.	RR or RS	Message wait time	Sum check code	ACK	Station No.	PC No.
----------	----	-----	-------------	--------	----------------	----------------------	-------------------	-----	-------------	--------

**Notes**

- The station number, PC number, number of devices, and sum check code are expressed in hexadecimal.

**Operation Examples**

[Example 1] To execute remote RUN at PC station No. 5 (with a message wait time set to 0 ms)

The sum check is calculated over this range

Computer	PC	ENQ	05	FF	RR	0C	5	ACK	05	FF
		05H	30H,35H	46H,46H	52H,52H	30H	43H,35H	06H	30H,35H	46H,46H

[Example 2] To execute remote STOP at PC station No. 0 (with message wait time set to 0 ms)

The sum check is calculated over this range

Computer	PC	ENQ	00	FF	RS	0C	1	ACK	00	FF
		05H	30H,30H	46H,46H	52H,53H	30H	43H,31H	06H	30H,30H	46H,46H

## 5.8 Reading the PC type name (PC command)

### 5.8.1 PC type codes

PC type name	Type name code (hex.)	PC type name	Type name code (hex.)
FX0N	8EH	A3CPU, A3NCP	A3H
FX, FX2C	8DH	A3ACPU	94H
A0J2HCPU	98H	A3HCPU, A3MCP	A4H
A1CPU, A1NCP	A1H	A3UCPU	84H
A1SCPU, A1SJCPU	98H	A4UCPU	85H
A2CPU(-S1), A2NCP(-S1), A2SCPU	A2H	A52GCP	9AH
A2ACPU	92H	A73CPU	A3H
A2ACPU-S1	93H	A7LMS-F	A3H
A2CCPU	9AH	AJ72P25 / R25	ABH
A2USCPU	82H	AJ72LP25 / BR15	8BH
A2CPU-S1, A2USCPU-S1	83H		

### 5.8.2 Control specification and example

#### Control specification

Protocol format 1 is shown.

PC type name read command

**Notes**

- The station number, PC number, number of devices, and sum check code are expressed in hexadecimal.

#### Specification example

To read the type name from PC station No. 15 (with message wait time set to 0 ms)

The sum check is calculated over this range

Indicates station No. 15 ("0F" in hexadecimal).

Indicates the type name of the PC is FX, FX2c series.

## 5.9 Global function (GW command)

This function is to turn on and off the global operation flag at all stations in the multidrop link. For an FX series PC this is special auxiliary relay M8126, and for an A series PC, it is Xn2 of the computer link unit. This function can be used for initialisation, resetting or simultaneous start/stop of all PC stations.

### 5.9.1 Control specification and example of global function

The global function is to turn on or off the special auxiliary relay M8126 (global operation flag) at all stations in the multidrop link.

- The station number specified in the control protocol must indicate all stations, and is hence specified as FFH ("FF"). If other than FFH is specified as the station number, the special auxiliary relay M8126 of the specified station is turned on/off.
- No reply is given by the PC to this command.
- If the PC power is turned off, the communication format changed, or the PC is stopped, the special auxiliary relay M8126 of that station is turned off, and the global function operation is cleared.

**Control specification**

Protocol format 1 is shown.

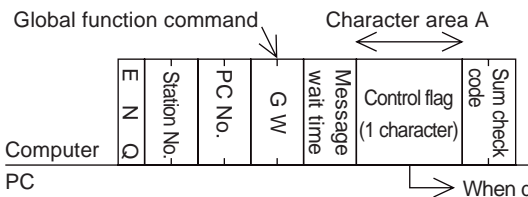



**Notes**

- The station number, PC number, number of devices, and sum check code are expressed in hexadecimal.

---

**Specification Example**

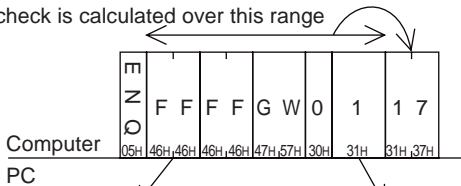
To turn on the global operation flag at all PC stations in the computer link; auxiliary relay M8126 in an FX series PC station, and Xn2 in an A series PC station.



"FF" is specified to indicate all stations.  
 For a specific station, specify the station number between "00" to "0F" ("00" to "1F" for A series).

Indicates that the global operation flag is turned ON.

### 5.10 On-demand function

Data transmission between the computer and the PC is usually initiated by the computer only. The on-demand function is used if there is a need to transmit data from the PC to the computer. The range of data registers containing the data to be sent is specified in special data registers.

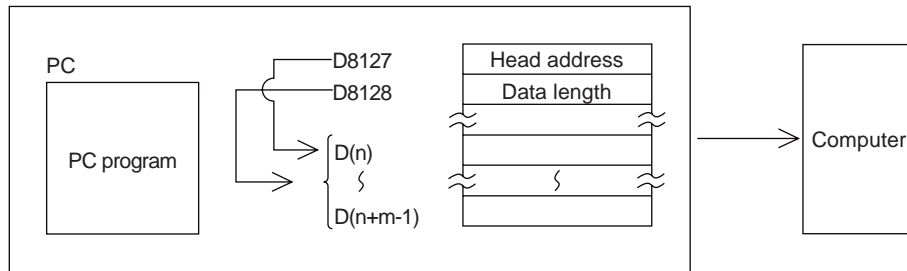

Notes

- This function can only be used when the configuration of the computer and PC CPU is 1:1.

#### 5.10.1 Special devices used in on-demand function

The special data registers and auxiliary relays used in the on-demand function are explained in the following table.

Device	Name	Description
M8127	On-demand handshake signal	ON during execution of on-demand ON : on-demand data being transmitted OFF: on-demand data transmission complete
M8128	On-demand error flag	ON if there is error in specified value for data transmission in on-demand ON : error OFF: no error
M8129	Flag for specifying word or byte data format	Word / byte data format for on-demand data. ON : byte units (8-bits per data register) OFF: word units (16-bits per data register)
D8127	On-demand head device number register	The head device number of the data area in which the data to be transmitted is stored. Set by PC program.
D8128	On-demand data length register	The data length to be transmitted by on-demand. Set by PC program.



Notes

- The on-demand handshake signal is a signal which is turned on when data transmission to the computer is started from the PC, and is turned off when transmission of the specified data is complete. This is used as an interlock so that multiple on-demand requests can not be issued simultaneously.

5.10.2 On-demand Control protocol

(1) Control protocol at PC

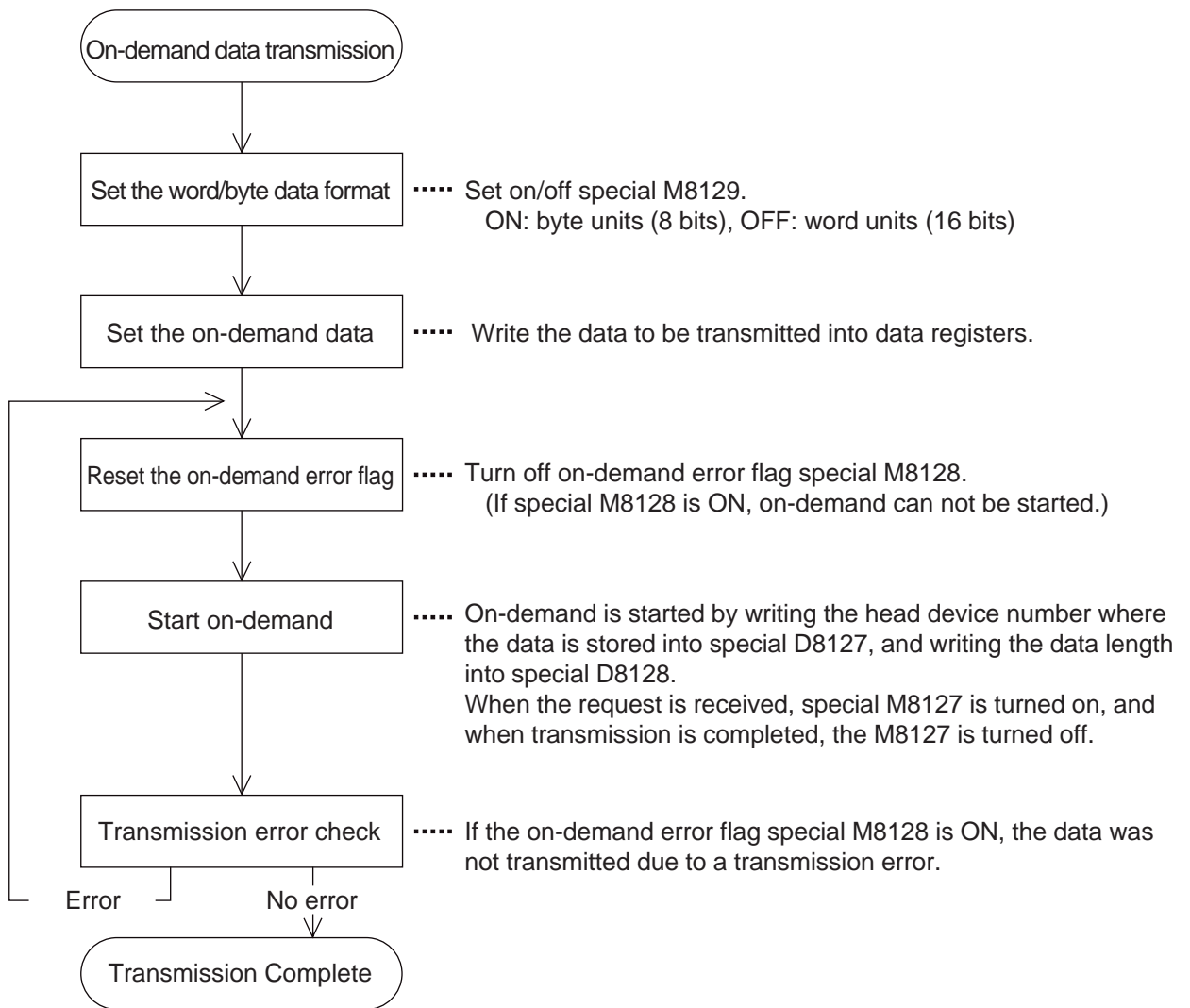

(2) Control protocol at computer

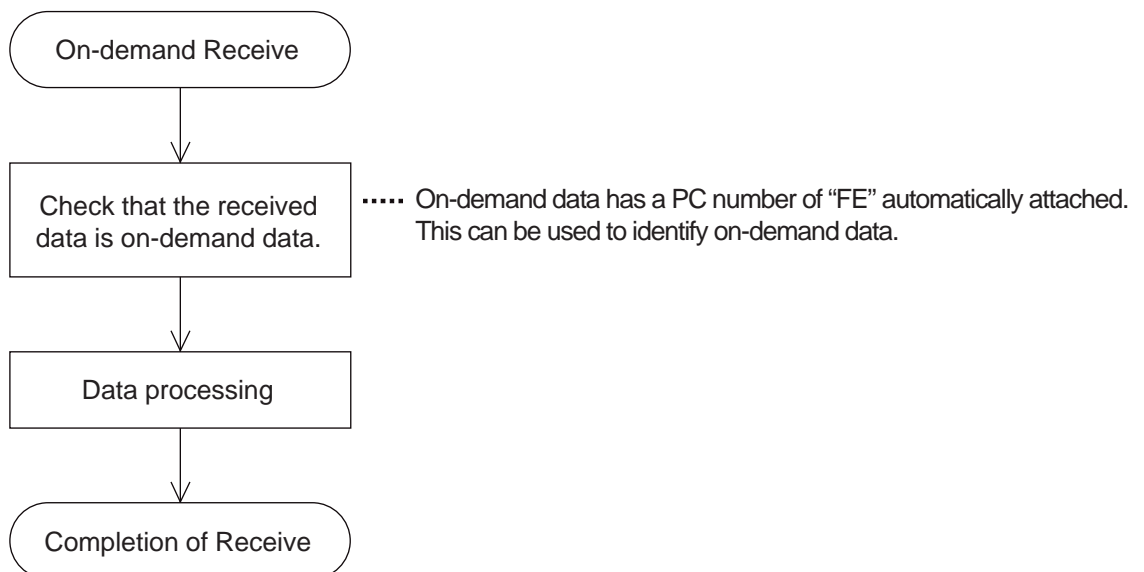

(3) On-demand request time chart.

When the computer is transmitting data

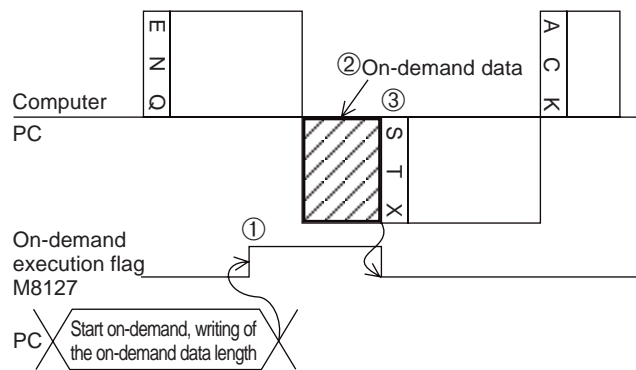

- 1) When on-demand is requested, the on-demand execution signal (special M8127) is immediately turned on.
- 2) Transmission of on-demand data is forced to wait until completion of reception of command data (ENQ-) from the computer.
- 3) Transmission of response data (STX-) to command data (ENQ-) is forced to wait until completion of transmission of on-demand data.

When the computer is receiving data

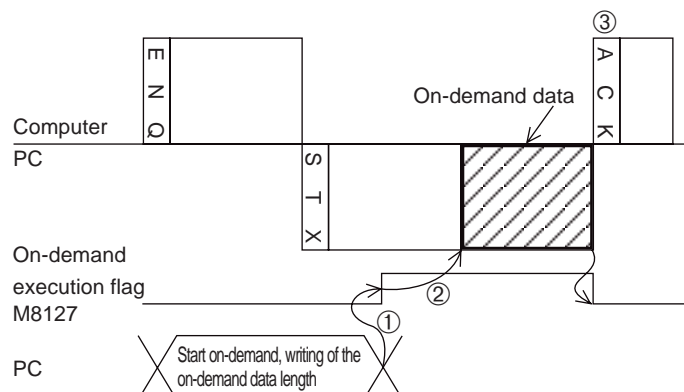

- 1) When on-demand is requested, the on-demand execution signal (special M8127) is immediately turned on.
- 2) Transmission of on-demand data is forced to wait until completion of transmission of response data (STX-) to the command data (ENQ-) from the computer.
- 3) Transmission of response data (ACK-) from the computer to the transmission of response data (STX-) from the PC should be done after completion of reception of on-demand data.

5.10.3 Specification and example of on-demand

**Command specification**

Protocol format 1 is shown.

Computer  
PC

Station No. PC No. Transmission data

Sum check code

Added by PC.

Special auxiliary relay M8127

ON OFF

PC Write processing

On-demand data is set, the head address is written to D8127 and the data length is written to D8128.

**Notes**

- (1) Specify the data length so as to satisfy the following condition.  
Data length ≤ 40H (64 points) (13 points for FX<sub>0N</sub>)
- (2) The PC number, "FE" is added by the PC.
- (3) The station number, PC number, number of devices, and sum check code are expressed in hexadecimal.



**Important**

- Don't use the on-demand function unless the system configuration is 1:1.
- If the on-demand function is used in a multidrop system in which the computer and the PC CPUs are connected in 1:n configuration, normal communication data in control protocol formats 1 to 4, and on-demand data become confused, and normal data transmission is not possible.

**Specification Example 1**

To transmit the data stored in data registers D100 and D101 from the PC (when the station number is 0, and data is specified in word units)

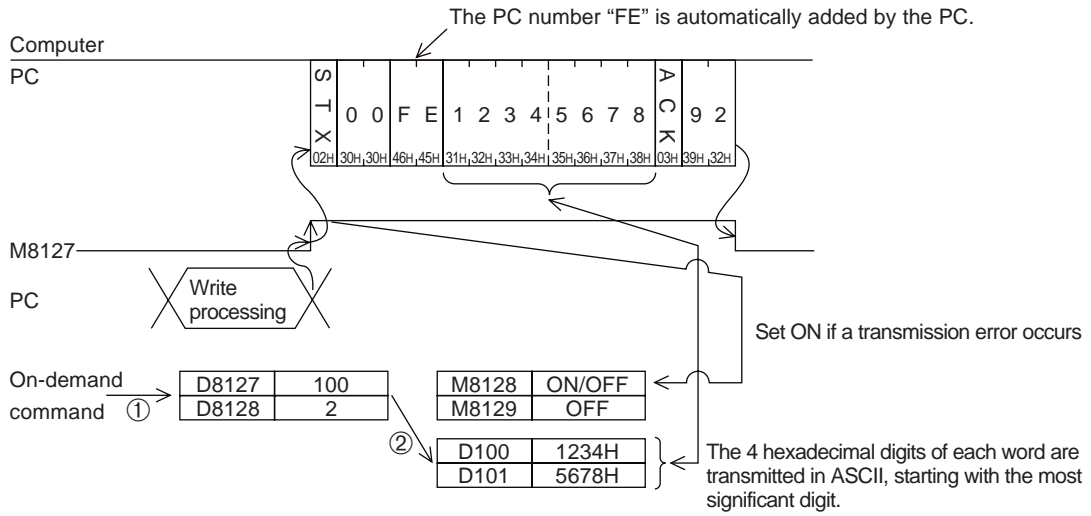

[PC program example]

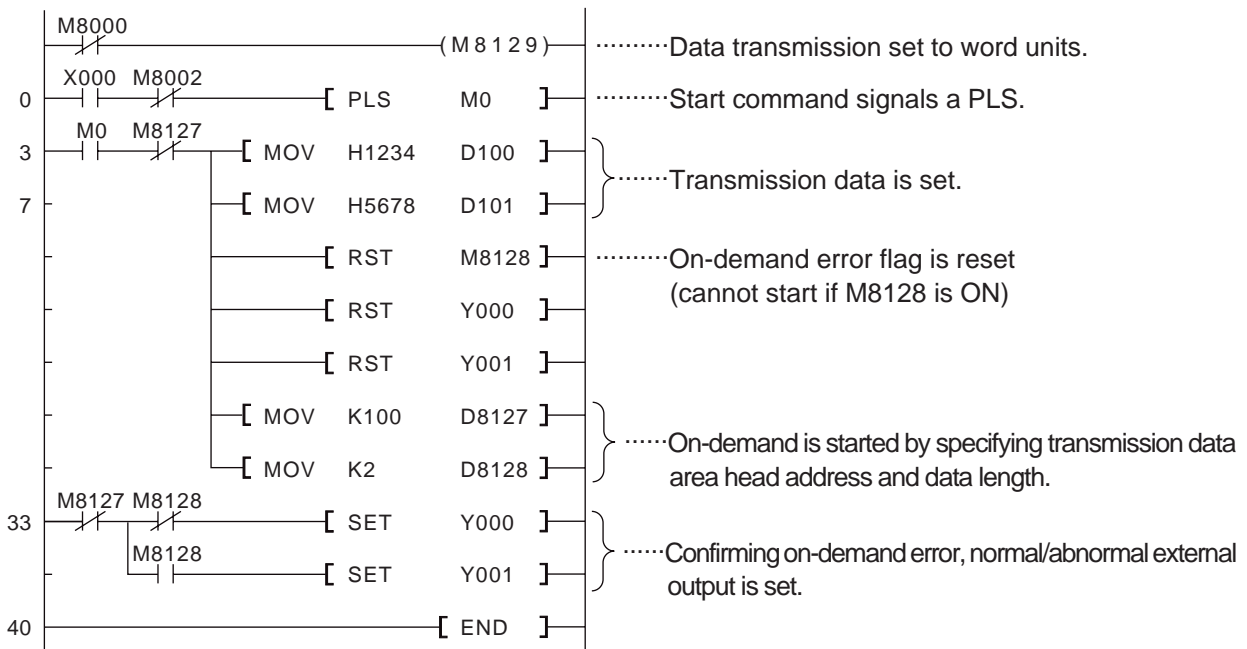

M8128 OFF: Normally transmitted.  
ON: Data is not transmitted due to error.

**Specification Example 2**

To transmit the data stored in data registers D100 and D101 from the PC (when the station number is 0, and data is specified in byte units)

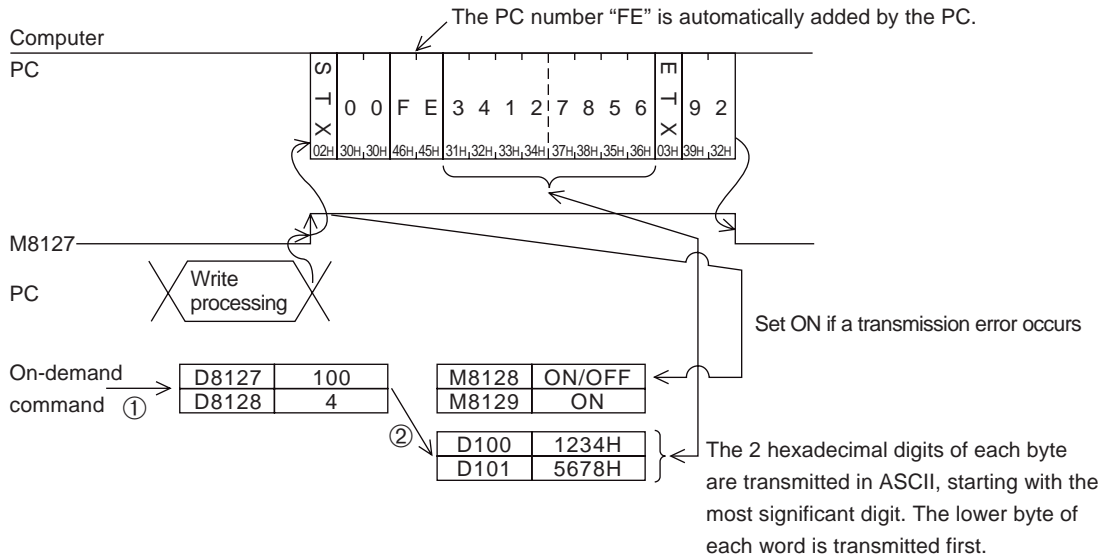

[PC program example]

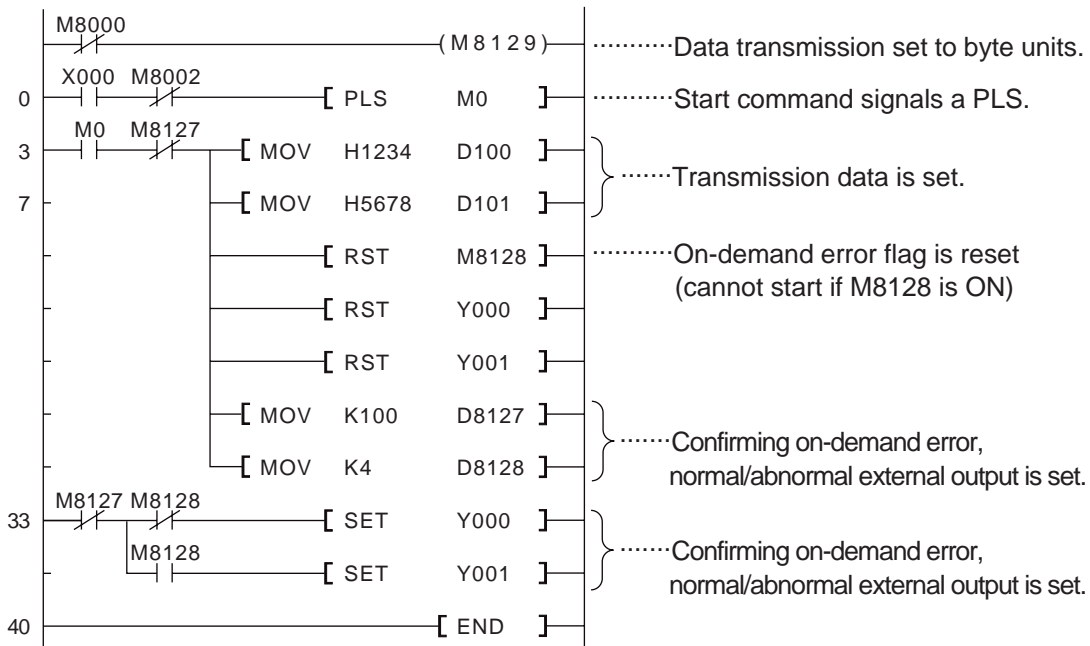

M8128 OFF: Normally transmitted.  
 ON: Data is not transmitted due to error.

### 5.11 Loopback test

The Loopback test is the function for testing if communication between the computer and PC is operating as normal or not.

**Command Specification**

Protocol format 1 is shown.

**Notes**

- Specify the number of characters so as to satisfy the following condition.
  - $1 \leq \text{No. characters} \leq 254$  (25 for FX0N)
- The station number, PC number, number of devices, and sum check code are expressed in hexadecimal.

**Specification example**

To test the Loopback with data "ABCDE" at station No. 0 (with message wait time set to 0 ms)

The sum check is calculated over this range

The sum check is calculated over this range

Same data is transmitted.

<b>1</b>	<b>Outline and system configuration</b>
<b>2</b>	<b>Specification</b>
<b>3</b>	<b>Settings and produres before operation</b>
<b>4</b>	<b>Communication using dedicated protocols</b>
<b>5</b>	<b>Commands</b>
<b>6</b>	<b>Diagnostics</b>
	<b>Appendix A</b>



## 6. Diagnostics

This chapter describes possible errors occurring in the link with the computer and troubleshooting hints. As for error codes and troubleshooting of A series programmable controller, see the manual of the A series programmable controller.

### 6.1 NAK Error codes

NAK error codes follow a NAK transmitted when an error occurs in communication between a PC and the computer. They have a value of 00H to FFH transmitted as two ASCII digits.

When multiple errors occur simultaneously, the error code with the lowest number is given priority, and this is transmitted. If the following errors should occur, all transmission is initialized.

List of error codes

Error code (hexadecimal)	Error	Error description	Remedy
02H	Sum check error	Sum check error The calculated and transmitted sum check codes do not match.	Check and correct the transmission data from the computer and the sum check value.
03H	Protocol error	Communication protocol is not valid Attempting to communicate with a different or partially different control protocol to that selected by D8120.	Check and correct the contents of D8120 and the communicated control protocol.
06H	Character area error	Error in command area A, B, C, or command not available. (1) The data area of the transmitted command does not conform to the protocol selected by D8120. (2) Requested command not available at specified PC. Requested device number does not exist in specified PC. (3) Device number is not specified using the correct number of characters (5 characters).	(1) Check and correct the command specification. (2) Check and correct the command or device number by referring to list of commands on section 4.7.1. (3) Check and correct the specified device numbers by referring to the device ranges on section 4.7.2.
10H	PC No. error	PC Number does not exist.	Check PC No. in message, correct, and communicate again. For FX series the PC No. must be FFH.
18H	Remote error	Remote run/stop operation can not be done. RUN is selected by hardware (Run/stop switch is used, etc.) or the PC is already in Run/stop.	Use forced run mode to RUN/STOP the PC for normal operation.

### 6.2 PC Error codes

Some communication errors give an error code at the PC without transmitting a NAK message to the computer.

When this kind of error occurs, the special auxiliary relay M8063 is turned on, and the error code is stored in the special data register D8063.

Error codes

Error code	Error	Error description	Remedy
6301	Parity, overrun, framing error	Transmission data is not normal.	Check and correct the transmission specification designated by D8120 and communicate again.
6305	Command failure	Station number is FF specified for a command other than GW.	Check and correct the transmitted command.
6306	Communication remote error	A complete message was not received before the time out check time elapsed. Communications are re-initialized.	The message is incomplete. Check the communication program of the computer and rating.

## 6.3 Diagnostics

This section refers to simple troubleshooting methods for use with the 485PC-IF and 485ADP. For troubles relating to the A series computer link unit or the computer please see the appropriate manual.

### 6.3.1 Diagnostic Flow Chart

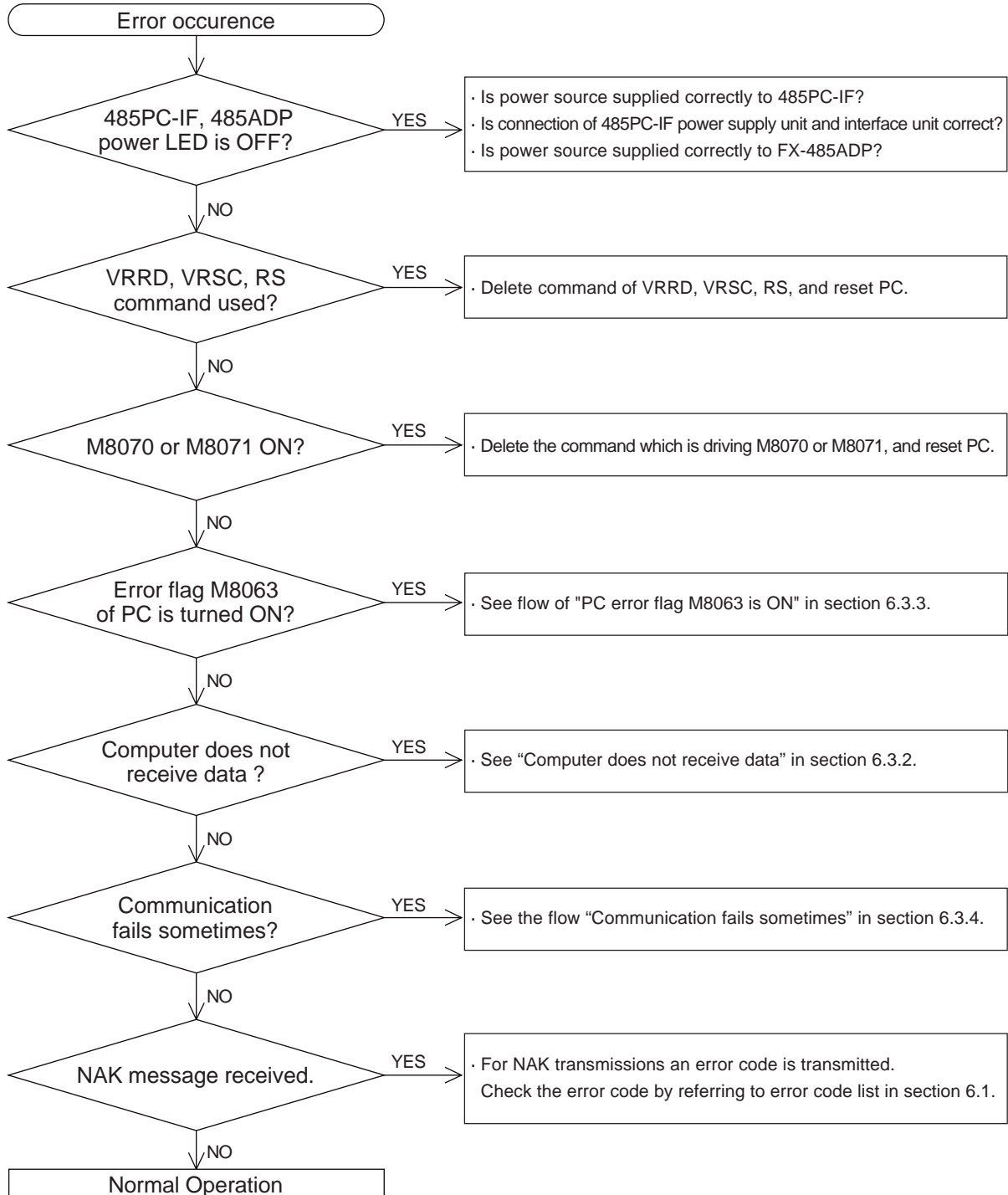

6.3.2 Computer does not receive data

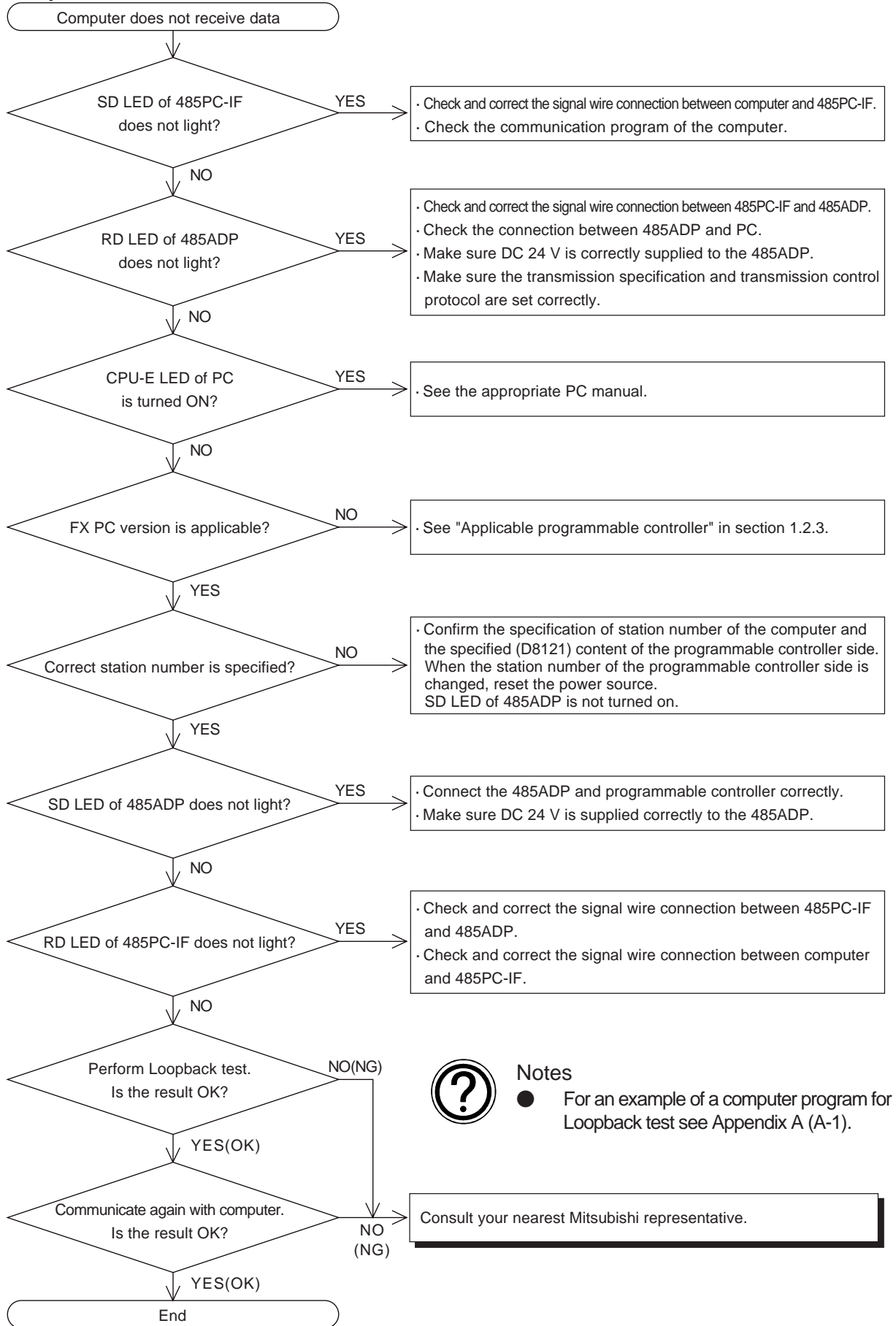

Notes

- For an example of a computer program for Loopback test see Appendix A (A-1).

Consult your nearest Mitsubishi representative.

6.3.3 PC error flag M8063 is ON

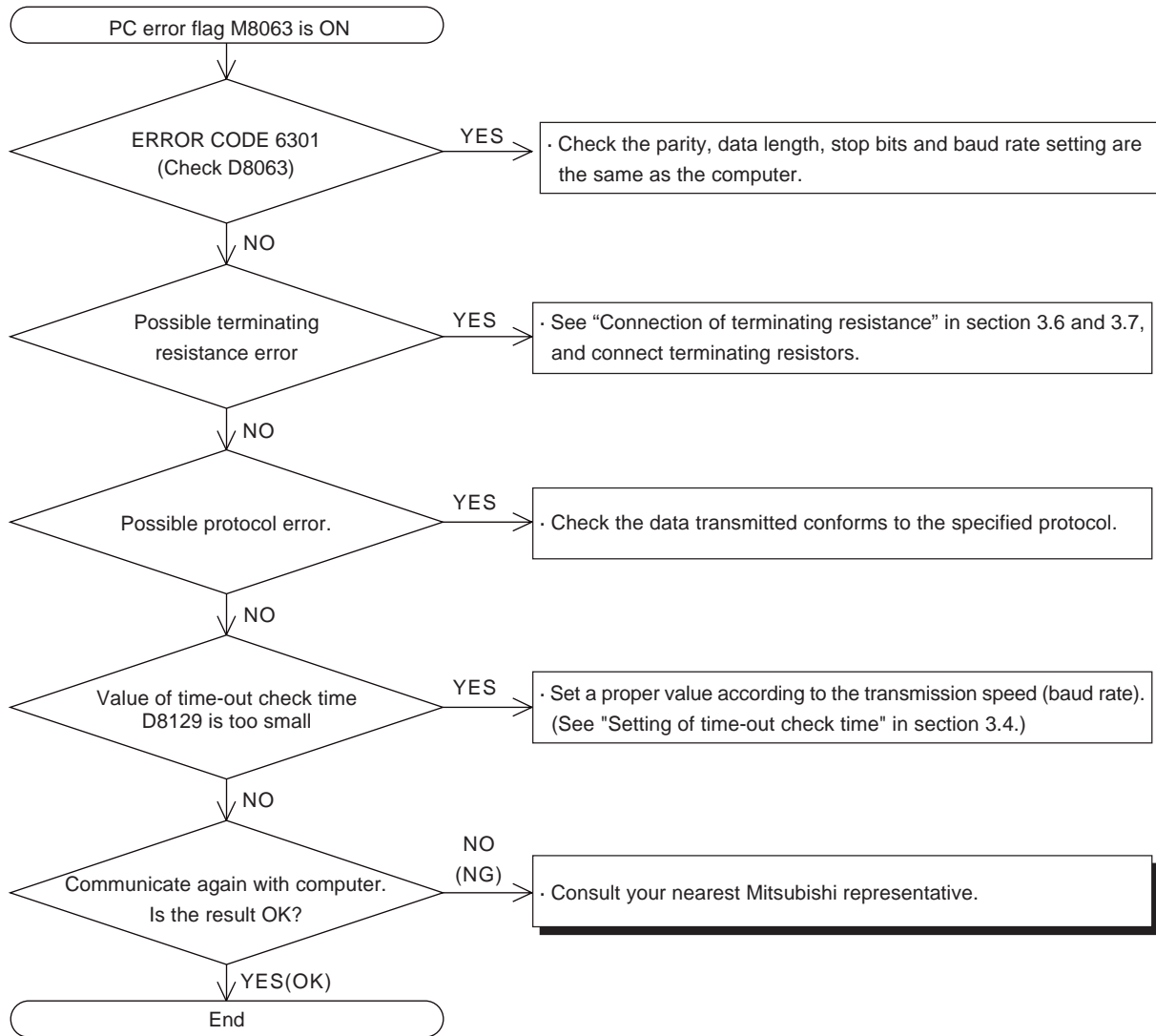

6.3.4 Communication fails sometimes

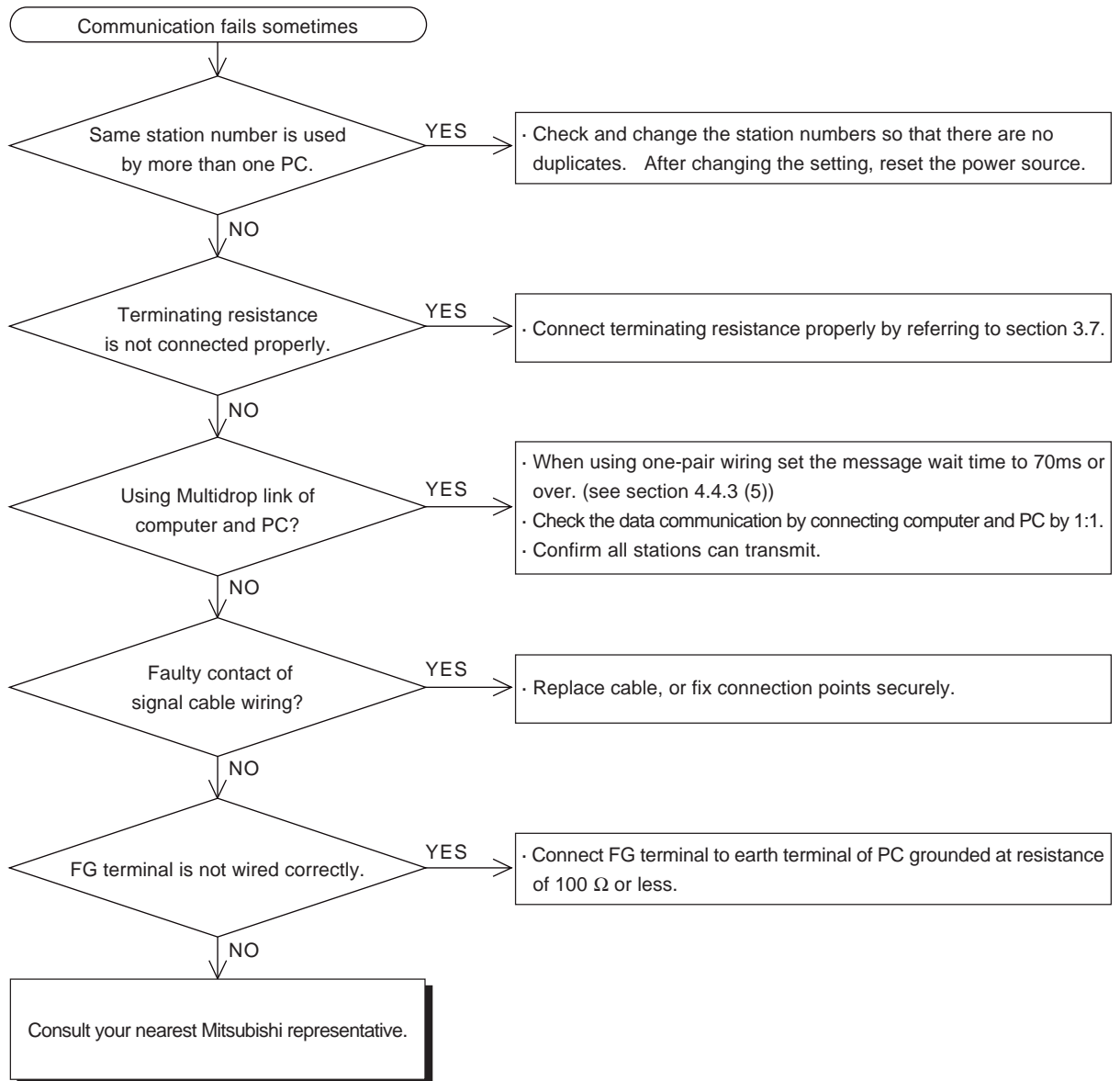



<b>1</b>	<b>Outline and system configuration</b>
<b>2</b>	<b>Specification</b>
<b>3</b>	<b>Settings and produres before operation</b>
<b>4</b>	<b>Communication using dedicated protocols</b>
<b>5</b>	<b>Commands</b>
<b>6</b>	<b>Diagnostics</b>
	<b>Appendix A</b>



# Appendix A

## Example computer program for Loopback command

This is an example of a BASIC program for communication of the computer link using a computer, programmable controller 485PC-IF, and 485ADP. (N88BASIC of Nippon Electric Corporation is used)

### (1) Setting of transmission specification

Item	Description	
Communication method	Half-duplex communication method	
Synchronizing method	Start-stop synchronization method	
Transmission speed	9600bps	
Data format	Start bit	1bit
	Data length	7bit
	Parity bit	None
	Stop bit	1bit
Sum check	Sum check is used	
Station No.	Station No. 0	
Exclusive protocol format	Format 1	

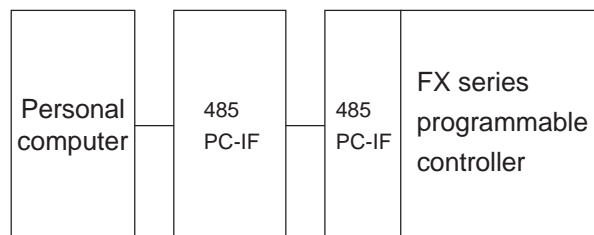

According to the above transmission specification, the transmission specification and transmission procedure of the programmable controller are set as follows.

```

D8120=H6080
D8121=H0000
D8129=K0
    } For setting and details, see section 3.2 to 3.4.
    
```

### (2) Program example

```

10 T0 = 3000           :' Reception wait counter (adjusted depending on computer speed)
20 STCNT = 14         :' Normal data length
30 NACNT = 7         :' Data length of error code (NAK statement)
40 ERFLG = 0
50 ENQ$ = CHR$(5)
60 STX$ = CHR$(2)
70 ETX$ = CHR$(3)
80 NAK$ = CHR$(&H15)
90 *DATASEND          :' Data transmission
100 CLOSE #1
110 OPEN"COM1": "AS #1
120 SENDDATA$="00FFTT204ABCD34" :' Transmission data
130 PRINT #1,ENQ$;SENDDATA$;
140 *REC0             :' Reception of first character
150 RVCNT = 1
160 GOSUB *RECWAIT
170 IF ERFLG = 99 THEN GOTO *ERRORFIN1
    
```

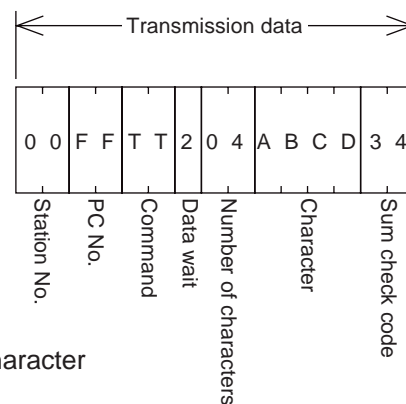

```

180 BUF$ = RCV$
190 HED$ = LEFT$(BUF$,1)
200 IF HED$ = STX$ OR HED$ = NAK$ THEN GOTO *REC1 ELSE GOTO *REC0
210 *REC1                                :'Reception of remaining data
220 IF HED$ = STX$ THEN RVCNT = STCNT-1
230 IF HED$ = NAK$ THEN RVCNT = NACNT-1
240 GOSUB *RECWAIT
250 IF ERFLG = 99 THEN GOTO *ERRORFIN1
260 BUF$ = BUF$+RCV$
270 *PRINTRDATA                          :'Display of received data
280 PRINT "Received data"
290 PRINT "HEX ASCII"
300 FOR I=1 TO LEN(BUF$)
310  PRT1$ = MID$(BUF$,I,1)
320  PRT1$ = HEX$(ASC(PRT1$))
330  IF PRT2$ = "2" THEN PRINT "    ";"02";"    ";"STX" :GOTO 370
340  IF PRT2$ = "3" THEN PRINT "    ";"03";"    ";"ETX" :GOTO 370
350  IF PRT2$ = "15" THEN PRINT "    ";"15";"    ";"NAK" :GOTO 370
360  PRINT "    ";"PRT2$;"    "CHR$(&H22);PRT1$;CHR$(&H22)
370  NEXT I
380 IF HED$ = NAK$ THEN GOTO *ERRORFIN2
390 *DATACHECK                            :'Check of received data
400 DDATA$ = STX$+"00FF04ABCD"+ETX$+"5D"    :'Normal data
410 FOR J=1 TO LEN(BUF$)
420  RDATA$ = MID$(BUF$,J,1)
430  ODATA$ = MID$(DDATA$,J,1)
440  IF RDATA$ <> ODATA$ THEN GOTO *ERRORFIN3
450  NEXT J
460 PRINT "Received data is normal"
470 PRINT "Loopback test complete":GOTO *FIN
480 *ERRORFIN1
490 PRINT "Data is not received at all or data content is insufficient."
500 GOTO *FIN
510 *ERRORFIN2
520 ERRORCODE$ = MID$(BUF$,6,2)
530 PRINT "Error code" ;ERRORCODE$; "H is received."
540 GOTO *FIN
550 *ERRORFIN3
560 PRINT "Received data is abnormal. (" ;J;"-th character)"
570 *FIN
580 CLOSE #1
590 END
600 *RECWAIT                              :'Wait for receive
610 FOR I=1 TO T0
620  RCV$ = ""
630  IF LOC(1) => RVCNT THEN GOTO *BUFIN
640  NEXT
650 IF RCV$ = "" THEN ERFLG=99
660 RETURN
670 *BUFIN                                :'Reading of received data
680 RCV$ = INPUT$(RVCNT,#1)
690 RETURN

```

## (3) Operation

- 1) Start the computer program.
- 2) Send four characters "ABCD" from the computer to the FX PC.
- 3) The FX PC returns the four characters "ABCD" back to the computer.
- 4) The computer compares the data received from the PC and the original sent data, and displays a result message.

## (4) List of result messages

Message	Remedy
Received data is normal.	Data sending and receiving is normal.
Data is not received at all or data content is insufficient.	Check again the wiring, station No., transmission specification, and transmission protocol.
Error code OOH is received.	Refer to error code list in chapter 6.
Received character is abnormal. (O-th character)	Check for faulty wiring, observing wiring cautions.









# MEMO

# ERRATA

Page	Section	Wrong	Right																
4-4	4.4.1 To write data from the computer to the PC.																		
4-5	4.4.2 To write data from the computer to the PC.																		
4-8	4.4.4 Notes																		
4-14	4.7.2 (1) Bit devices	<table border="1" style="width: 100%; border-collapse: collapse;"> <thead> <tr> <th colspan="2">Device specification characters</th> </tr> <tr> <th>FX0N</th> <th>FX2,FX2C</th> </tr> </thead> <tbody> <tr> <td>X0000~X0177</td> <td>X0000~X0377</td> </tr> <tr> <td>Y0000~Y0177</td> <td>Y0000~Y0377</td> </tr> </tbody> </table>	Device specification characters		FX0N	FX2,FX2C	X0000~X0177	X0000~X0377	Y0000~Y0177	Y0000~Y0377	<table border="1" style="width: 100%; border-collapse: collapse;"> <thead> <tr> <th colspan="2">Device specification characters</th> </tr> <tr> <th>FX0N</th> <th>FX2,FX2C</th> </tr> </thead> <tbody> <tr> <td>X0000~X0177</td> <td>X0000~X0337</td> </tr> <tr> <td>Y0000~Y0177</td> <td>Y0000~Y0337</td> </tr> </tbody> </table>	Device specification characters		FX0N	FX2,FX2C	X0000~X0177	X0000~X0337	Y0000~Y0177	Y0000~Y0337
Device specification characters																			
FX0N	FX2,FX2C																		
X0000~X0177	X0000~X0377																		
Y0000~Y0177	Y0000~Y0377																		
Device specification characters																			
FX0N	FX2,FX2C																		
X0000~X0177	X0000~X0337																		
Y0000~Y0177	Y0000~Y0337																		

# MEMO

Headquarters		European Representatives	
<p><b>EUROPE</b></p> <p>MITSUBISHI ELECTRIC EUROPE B.V. Gothaer Str. 8 <b>D-40880 Ratingen</b> <b>GERMANY</b> Phone: +49 (0) 2102 / 486 0 Fax: +49 (0) 2102 / 486 112</p>		<p><b>AUSTRIA</b></p> <p>GEVA Wiener Straße 89 <b>A-2500 Baden</b> Phone: +43 (0) 2252 / 85 55 20 Fax: +43 (0) 2252 / 488 60</p>	
<p><b>ITALY</b></p> <p>MITSUBISHI ELECTRIC EUROPE B.V. C.D. Colleoni - P. Perseo Ing. 2, Via Paracelso 1 <b>I-20041 Agrate Brianza (MI)</b> <b>ITALY</b> Phone: +39 039 6053 1 Fax: +39 039 6053 312</p>		<p><b>BELGIUM</b></p> <p>N.V. GETRONICS Belgium S.A. Pontbeeklaan 43 <b>B-1731 Asse-Zellik</b> Phone: +32 (0) 2 / 467 17 51 Fax: +32 (0) 2 / 467 17 45</p>	
<p><b>SPAIN</b></p> <p>MITSUBISHI ELECTRIC EUROPE B.V. Pol. Ind. Can Magi-C. Joan Buscallá, 2-4 AC 420 <b>E-08190 Sant Cugat del Vallés (Barcelona)</b> <b>SPAIN</b> Phone: +34 (9) 3 / 565 31 60 Fax: +34 (9) 3 / 589 15 79</p>		<p><b>BULGARIA</b></p> <p>TELECON CO. 4, A. Ljapchev Blvd. <b>BG-1756 Sofia</b> Phone: +359 92 97 44 05 8 Fax: +359 92 97 44 06 1</p>	
<p><b>UK</b></p> <p>MITSUBISHI ELECTRIC EUROPE B.V. Travellers Lane <b>GB-Hatfield Herts. AL10 8 XB</b> <b>UK</b> Phone: +44 (0) 1707 / 27 61 00 Fax: +44 (0) 1707 / 27 86 95</p>		<p><b>CZECHIA</b></p> <p>AutoCont Control Systems s.r.o. Nemocnicni 12 <b>CZ-702 00 Ostrava 2</b> Phone: +420 (0) 69 / 615 21 11 Fax: +420 (0) 69 / 615 21 12</p>	
<p><b>JAPAN</b></p> <p>MITSUBISHI ELECTRIC CORPORATION 2-2-3 Marunouchi Chiyoda-Ku <b>Tokyo 100-8310</b> <b>JAPAN</b> Phone: +81 (0) 3 / 32 18 31 76 Fax: +81 (0) 3 / 32 18 24 22</p>		<p><b>DENMARK</b></p> <p>louis poulsen Geminivej 32 <b>DK-2670 Greve</b> Phone: +45 (0) 43 / 95 95 95 Fax: +45 (0) 43 / 95 95 91</p>	
<p><b>USA</b></p> <p>MITSUBISHI ELECTRIC AUTOMATION, INC. 500 Corporate Woods Parkway <b>Vernon Hills, Illinois 60061</b> <b>USA</b> Phone: +1 / 847 / 478 21 00 Fax: +1 / 847 / 478 22 83</p>		<p><b>ESTONIA</b></p> <p>UTU ELEKTROTEHNIKA AS Laki 12E <b>EE-10621 Tallinn</b> Phone: +372 6 / 51 72 80 Fax: +372 6 / 51 72 88</p>	
		<p><b>FINLAND</b></p> <p>Beijer Electronics OY Elannontie 5 <b>FIN-01510 Vantaa</b> Phone: +358 (0) 9 / 615 20 11 Fax: +358 (0) 9 / 615 20 500</p>	
		<p><b>FRANCE</b></p> <p>IP Systèmes 8, Rue du Colonel Chambonnet <b>F-69672 Lyon Bron Cedex</b> Phone: +33 (0) 4 / 72 14 18 00 Fax: +33 (0) 4 / 72 14 18 01</p>	
		<p><b>IRELAND</b></p> <p>MITSUBISHI ELECTRIC EUROPE B.V. Westgate Business Park, Ballymount <b>IRL-Dublin 24</b> Phone: +353 (0) 1 / 419 88 00 Fax: +353 (0) 1 / 419 88 90</p>	
		<p><b>ISRAEL</b></p> <p>ILAN &amp; GAVISH Automation Service 24 Shenkar St., Qiryat-Arie 49513 <b>IL-Petach-Tikva 49001</b> Phone: +972 (0) 3 / 922 18 24 Fax: +972 (0) 3 / 972 39 24 07 61</p>	
		<p><b>ISRAEL</b></p> <p>TEXEL Electronics Ltd. P.O. Box 6272 <b>IL-Netanya 42160</b> Phone: +972 (0) 9 / 863 08 91 Fax: +972 (0) 9 / 885 24 30</p>	
		<p><b>NETHERLANDS</b></p> <p>Getronics Industrial Automation bv Donauweg 10 <b>NL-1043 AJ Amsterdam</b> Phone: +31 (0) 20 / 586 15 92 Fax: +31 (0) 20 / 586 19 27</p>	
		<p><b>NORWAY</b></p> <p>Beijer Electronics AS Teglværksveien 1 <b>N-3002 Drammen</b> Phone: +47 (0) 32 / 24 30 00 Fax: +47 (0) 32 / 84 85 77</p>	
		<p><b>POLAND</b></p> <p>MPL Technology Sp. z o.o. ul. Wroclawska 53 <b>PL-30011 Kraków</b> Phone: +48 (0) 12 / 632 28 85 Fax: +48 (0) 12 / 632 47 82</p>	
		<p><b>ROMANIA</b></p> <p>Sirius Trading &amp; Services srl Bd. Ghica nr. 112, Bl. 41, Sc.2, ap. 98 <b>RO-72335 Bucuresti 2</b> Phone: +40 (0) 1 / 210 55 11 Fax: +40 (0) 1 / 210 55 11</p>	
		<p><b>RUSSIA</b></p> <p>Mitsubishi Electric Europe B.V. 12/1 Gonchamaya St, suite 3C <b>RUS-109240 Moscow</b> Phone: +7 (0) 95 / 915-8624/02 Fax: +7 (0) 95 / 915-8603</p>	
		<p><b>RUSSIA</b></p> <p>NPP Uralelektra Sverdlova 11A <b>RU-620027 Ekaterinburg</b> Phone: +7 (34 32) 53 27 45 Fax: +7 (34 32) 53 24 61</p>	
		<p><b>SLOVAKIA</b></p> <p>ACP AUTOCOMP a.s. Chalupkova 7 <b>SK-81109 Bratislava</b> Phone: +421 (0) 7 592 2248 Fax: +421 (0) 7 592 2254</p>	
		<p><b>SLOVENIA</b></p> <p>INEA d.o.o. Ljubljanska 80 <b>SI-61230 Domzale</b> Phone: +386 (0) 17 21 80 00 Fax: +386 (0) 17 24 16 72</p>	
		<p><b>SWEDEN</b></p> <p>Beijer Electronics AB Box 325 <b>S-20123 Malmö</b> Phone: +46 (0) 40 / 35 86 00 Fax: +46 (0) 40 / 93 23 01</p>	
		<p><b>SWITZERLAND</b></p> <p>ECONOTEC AG Postfach 282 <b>CH-8309 Nürensdorf</b> Phone: +41 (0) 1 / 838 48 11 Fax: +41 (0) 1 / 838 48 12</p>	
		<p><b>TURKEY</b></p> <p>GTS Darülaceze Cad. No. 43A KAT: 2 <b>TR-80270 Okmeydani-Istanbul</b> Phone: +90 (0) 212 / 320 1640 Fax: +90 (0) 212 / 320 1649</p>	
		<p><b>UKRAINE</b></p> <p>JV-CSC Automation 15, M. Raskovoyi St., Floor 10, Office 1010 <b>U-02002 Kiev</b> Phone: +380 (4) 4 / 238 83 16 Fax: +380 (4) 4 / 238 83 17</p>	