

JY997D36701A

Changes for the Better



PROGRAMMABLE CONTROLLERS
MELSEC-F

FX3U-2HC

USER'S MANUAL

Manual Number	JY997D36701
Revision	A
Date	December 2009



This manual describes the part names, dimensions, mounting, wiring, and specifications of the product. Before use, read this manual and the manuals of all relevant products fully to acquire proficiency in handling and operating the product. Make sure to learn all the product information, safety information, and precautions. Store this manual in a safe place so that it can be taken out and read whenever necessary. Always forward it to the end user. Registration: The company and product names described in this manual are registered trademarks or the trademarks of their respective companies. Effective December 2009. Specifications are subject to change without notice. © 2009 Mitsubishi Electric Corporation

Safety Precaution (Read these precautions before use.)

This manual classifies the safety precautions into two categories:

⚠ DANGER and **⚠ CAUTION**.

⚠ DANGER	Indicates that incorrect handling may cause hazardous conditions, resulting in death or severe injury.
⚠ CAUTION	Indicates that incorrect handling may cause hazardous conditions, resulting in medium or slight personal injury or physical damage.

Depending on the circumstances, procedures indicated by **⚠ CAUTION** may also cause severe injury. It is important to follow all precautions for personal safety.

Associated Manuals

Manual name	Manual No.	Description
FX3U Series User's Manual - Hardware Edition	JY997D16501 MODEL CODE: 09R516	Explains the FX3U Series PLC specifications for I/O, wiring, installation, and maintenance.
FX3UC Series User's Manual - Hardware Edition	JY997D28701 MODEL CODE: 09R519	Explains the FX3UC Series PLC specifications for I/O, wiring, installation, and maintenance.
FX3G/FX3U/FX3UC Series Programming Manual - Basic & Applied Instruction Edition	JY997D16601 MODEL CODE: 09R517	Describes FX3G/FX3U/FX3UC Series PLC programming for basic/applied instructions and devices.

How to obtain manuals

For product manuals or documents, consult with the Mitsubishi Electric dealer from who you purchased your product.

Certification of UL, cUL standards

The following product has UL and cUL certification.

UL, cUL File Number: E95239

Models: MELSEC FX3U series manufactured from December 1st, 2009 FX3U-2HC

Compliance with EC directive (CE Marking)

This note does not guarantee that an entire mechanical module produced in accordance with the contents of this note will comply with the following standards. Compliance to EMC directive and LVD directive for the entire mechanical module should be checked by the user / manufacturer. For more details please contact the local Mitsubishi Electric sales site.

Requirement for Compliance with EMC directive

The following products have shown compliance through direct testing (of the identified standards below) and design analysis (through the creation of a technical construction file) to the European Directive for Electromagnetic Compatibility (2004/108/EC) when used as directed by the appropriate documentation.

Attention

- This product is designed for use in industrial applications.
- Manufactured by: Mitsubishi Electric Corporation
2-7-3 Marunouchi, Chiyoda-ku, Tokyo, 100-8310 Japan
- Manufactured at: Mitsubishi Electric Corporation Himeji Works
840 Chiyoda-machi, Himeji, Hyogo, 670-8677 Japan
- Authorized Representative in the European Community: Mitsubishi Electric Europe B.V.
Gothaer Str. 8, 40880 Ratingen, Germany

Type: Programmable Controller (Open Type Equipment)

Models: MELSEC FX3U series manufactured from December 1st, 2009 FX3U-2HC

Standard	Remark
EN61131-2:2003 Programmable controllers - Equipment requirements and tests	Compliance with all relevant aspects of the standard. EMI • Radiated Emissions • Conducted Emissions EMS • Radiated electromagnetic field • Fast Transient burst • Electrostatic discharge • High-energy surge • Voltage drops and interruptions • Conducted RF • Power frequency magnetic field

Caution for EC Directive

- Installation in Enclosure
Programmable logic controllers are open-type devices that must be installed and used within conductive control cabinets. Please use the programmable logic controller while installed within a conductive shielded control cabinet. Please secure the cabinet door to the control cabinet (for conduction). Installation within a control cabinet greatly affects the safety of the system and aids in shielding noise from the programmable logic controller.

1. Outline

1.1 Outline

The hardware high-speed counter block is a 2-channel high-speed counter. It is a special function block for the FX3U and FX3UC series PLC.

1.2 Major Features of the FX3U-2HC

- Differential-Line-Driver (AM26C31 or equivalent) and open collector output encoders are available for the FX3U-2HC.
- The FX3U-2HC has two outputs per channel. When the counter value coincides with an output compare value, the appropriate output is set ON. The output transistors are individually isolated to allow either sink or source connection methods.
- Various counter modes, such as 1-phase or 2-phase, 16-bit or 32-bit modes, can be selected using commands in the sequence program. Allow the FX3U-2HC unit to run only after setting these mode parameters.

1.3 Incorporated Items

Verify that the following product and items are included in the package:

Included Items	
FX3U-2HC	1 Unit
Special unit/block No. label	1 Sheet
Dust proof protection sheet	1 Sheet
Manuals [Japanese version]	1 manual
Manuals [English version] (This manual)	1 manual

1.4 External Dimensions, Part Names, and Terminal Layout

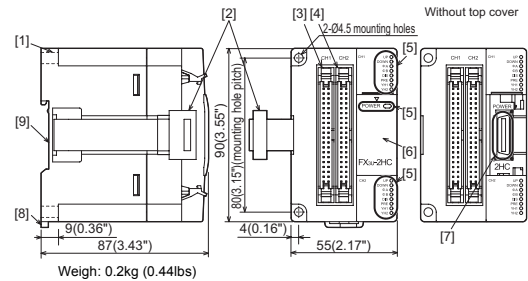

No.	Name	
[1]	Direct mounting hole: 2 holes of $\phi 4.5$ (0.18") (mounting screw: M4 screw) Used when attaching FX3U-2HC directly.	
[2]	Extension cable (PLC side) Used to connect this special function block to the FX3U/FX3UC main unit or an extension block.	
[3]	CH1 connector	
[4]	CH2 connector	
	Status LED (the upper side: CH1, the lower side: CH2)	
	POWER (Green)	Power LED ON when the 5V power supply is normally supplied from the PLC.
	UP (Red)	Up count LED The respective LED is ON according to up/down count direction of the counter.
	DOWN (Red)	Down count LED
[5]	Φ A (Red)	A phase input LED The respective LED is ON (flicker) according to ON/OFF of Φ A and Φ B input.
	Φ B (Red)	B phase input LED
	DIS (Red)	DISABLE input LED The respective LED is ON/OFF according to ON/OFF of PRESET and DISABLE input.
	PRE (Red)	PRESET input LED
	YH1 (Red)	YH1 output LED The respective LED is ON/OFF according to status of YH1 and YH2 output.
	YH2 (Red)	YH2 output LED
[6]	Top cover	
[7]	Extension connector (Extension side) Used to connect a FX3U extension block to the right of this special function block. Remove top cover for connecting.	
[8]	DIN rail mounting hook	
[9]	DIN rail mounting groove (DIN rail: DIN46277, 35mm (1.38") width)	

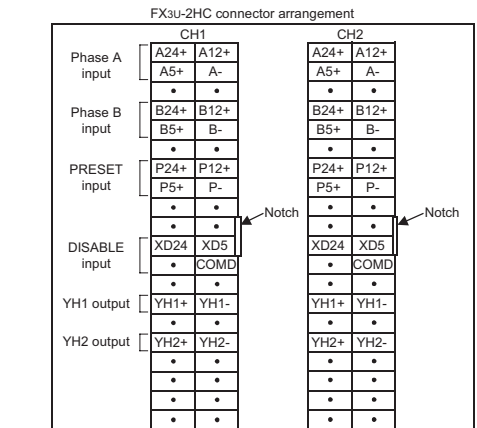

2. Installation, Connect to the PLC

INSTALLATION PRECAUTIONS **⚠ DANGER**

- Make sure to cut off all phases of the power supply externally before attempting installation or wiring work. Failure to do so may cause electric shock or damage to the product.

INSTALLATION PRECAUTIONS **⚠ CAUTION**

- Use the product within the generic environment specifications described in PLC main unit manual. Never use the product in areas with excessive dust, oily smoke, conductive dusts, corrosive gas (salt air, Cl₂, H₂S, SO₂, or NO₂), flammable gas, vibration or impacts, or expose it to high temperature, condensation, or rain and wind. If the product is used in such conditions, electric shock, fire, malfunctions, deterioration or damage may occur.
- Do not touch the conductive parts of the product directly. Doing so may cause device failures or malfunctions.
- Install the product on a flat surface. If the mounting surface is rough, undue force will be applied to the PC board, thereby causing nonconformities.
- When drilling screw holes or wiring, make sure cutting or wire debris does not enter the ventilation slits. Failure to do so may cause fire, equipment failures or malfunctions.
- Be sure to remove the dust proof sheet from the PLC's ventilation port when installation work is completed. Failure to do so may cause fire, equipment failures or malfunctions.
- Connect extension cables securely to their designated connectors. Loose connections may cause malfunctions.

2.1 Mounting

The product is mounted by the following method.

- DIN rail mounting
- Direct mounting (mounting screw: M4 screw)

For further information on installation arrangements, refer to the following manuals.
→ Refer to the **FX3U Series User's Manual - Hardware Edition**.
→ Refer to the **FX3UC Series User's Manual - Hardware Edition**.

2.1.1 DIN Rail Mounting

The product can be mounted on a DIN rail (DIN46277, 35mm (1.38") width).

- Fit the upper edge of the DIN rail mounting groove (fig. A) onto the DIN rail.
- Press the product against the DIN rail.
 - An interval space of 1 to 2 mm (0.04" to 0.08") between each unit is necessary.

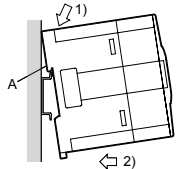

2.1.2 Direct Mounting (mounting screw: M4 screw)

The product can be installed directly with screws.

Refer to the External Dimensions (section 1.4) for the product's mounting hole pitch information.

An interval space between each unit of 1 to 2 mm (0.04" to 0.08") is necessary.

2.2 Connection to the PLC

A maximum of eight¹ FX3U-2HC(s) are connectable to the main unit or the right side of the powered extension unit/block. A unit number of No.0 to No.7 is assigned based on the order in which special function units/blocks are attached to the main unit.

For connection to an FX3UC Series PLC or FX2NC Series PLC extension block, an FX2NC-CNV-IF or FX3UC-1PS-5V is required.

¹ Up to seven special function units/blocks in total can be connected to the FX3UC-32MT-LT(-2) PLC. Unit numbers assigned to special function units/blocks begins with No.1.

For further information on installation arrangements, refer to the following manuals.

→ Refer to the **FX3U Series User's Manual - Hardware Edition**.
→ Refer to the **FX3UC Series User's Manual - Hardware Edition**.

3. Wiring (Power supply and analog input)

WIRING PRECAUTIONS **⚠ DANGER**

- Make sure to cut off all phases of the power supply externally before attempting installation or wiring work. Failure to do so may cause electric shock or damage to the product.

5. Buffer Memories (BFM)

5.1 Buffer memory List

Note:

- When writing to BFM #0 (CH1 counter mode), BFM #1 to #27 and #29 bit1 to 6 will be initialized. When writing to BFM #40 (CH2 counter mode), BFM #41 to #67 and #29 bit10 to 15 will be initialized. When setting the counter mode, use a TOP (pulsed) instruction, or M8002 (initial pulse) to drive the TO instruction. (The continuous operation type cannot be used.)
- Read/Write of 16 bit data
When using a positive value between K32,768 and K65,535 with 16 bit counters, read/writes of data, such as the current value, ring length, preset data, YH1/YH2 compare value, maximum count value and the minimum count value should use the 32-bit forms of FROM/TO instructions ((D) FROM, (D) TO).
- Read/write of 32 bit data
The usage of a 32-bit FROM/TO instruction is recommended. In the event that a 16-bit FROM/TO instruction is used, the following cases need to be considered.
 - If the writing order is low word first and then high word, the 32 bit data will be written normally. Data becomes valid after both low and high words are written.
 - In the event that data is not written in the order low word first and then high word, the error bit b7 of BFM #29 turns ON.

BFM #		Description	Default	BFM Access
CH1	CH2			
BFM #0	BFM #40	Counter mode (Setting range: K0 to K11)	K0	R/W
BFM #1	BFM #41	DOWN/UP command (1-phase 1-input mode [S/W UP/DOWN] only)	K0	R/W
BFM #2	BFM #42	Ring length	Lower K65536	R/W
BFM #3	BFM #43		Upper	R/W
BFM #4	BFM #44	Command	K0	R/W
BFM #5 ~ #9	BFM #45 ~ #49	Not used	-	-
BFM #10	BFM #50	Preset data	Lower K0	R/W
BFM #11	BFM #51		Upper	R/W
BFM #12	BFM #52	YH1 compare value	Lower K32767	R/W
BFM #13	BFM #53		Upper	R/W
BFM #14	BFM #54	YH2 compare value	Lower K32767	R/W
BFM #15	BFM #55		Upper	R/W
BFM #16 ~ #19	BFM #56 ~ #59	Not used	-	-
BFM #20	BFM #60	Counter current value	Lower K0	R/W
BFM #21	BFM #61		Upper	R/W
BFM #22	BFM #62	Maximum count value	Lower K0	R/W
BFM #23	BFM #63		Upper	R/W
BFM #24	BFM #64	Minimum count value	Lower K0	R/W
BFM #25	BFM #65		Upper	R/W
BFM #26	BFM #66	Compare results	-	R
BFM #27	BFM #67	Terminal status	-	R
BFM #28		Not used	-	-
BFM #29		Error status	-	R
BFM #30		Model identification code: K4020	K4020	R
BFM #31 ~ 39		Not used	-	-
BFM #68 ~ 32767		Not used	-	-

5.2 Details of buffer memories

5.2.1 Counter mode [BFM #0 (CH1), #40 (CH2)]

The counter mode is shown in the upper right table. (Default value: K0)

Note:

When writing to BFM #0 (CH1 counter mode), BFM #1 to #27 and #29 bit1 to 6 will be initialized. When writing to BFM #40 (CH2 counter mode), BFM #41 to #67 and #29 bit10 to 15 will be initialized. Please perform the setting of other BFM(s) after the setting of the counter mode (BFM #0, #40).
When setting the counter mode, use a TOP (pulsed) instruction, or M8002 (initial pulse) to drive the TO instruction. (The continuous operation type cannot be used.)

Count modes	32 bits	16 bits	Reference
2-phase input (phase difference pulse)	1 edge count	K0	K1 (1, 2)
	2 edge count	K2	K3 (1, 3)
	4 edge count	K4	K5 (1, 4)
1-phase 2-input (add/subtract pulse)		K6	K7 (1, 5)
1-phase 1-input	Hardware UP/DOWN	K8	K9 (1, 6)
	Software UP/DOWN	K10	K11 (1, 7)

1) 16/32-bit counter modes

a) 32-bit counter modes
Modes: K0, K2, K4, K6, K8, K10
A 32-bit binary counter which executes UP/DOWN counting will change from the lower limit value to the upper limit value or the upper limit value to the lower limit value when overflow occurs. Both the upper and lower limit values are fixed values: the upper limit value is +2,147,483,647, and the lower limit value is -2,147,483,648.

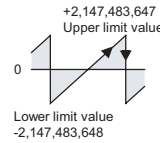

b) 16-bit counter modes

Modes: K1, K3, K5, K7, K9, K11
A 16-bit binary counter handles only positive values from 0 to 65,535. Changes to zero from the upper limit value or to the upper limit value from zero when overflow occurs; the upper limit value is determined by BFM #3 and #2 (CH1), #43 and #42 (CH2).

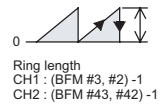

2) 2-phase counter [1 edge-count] (K0, K1)

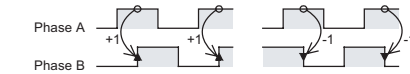

Phase B input OFF → ON while phase A input ON Count up by 1.
Phase B input ON → OFF while phase A input ON Count down by 1.

3) 2-phase counter [2 edge-count] (K2, K3)

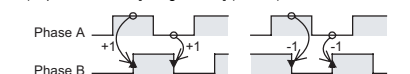

Phase B input OFF → ON (ON → OFF) while phase A input ON (OFF) Count up by 1.
Phase B input ON → OFF (OFF → ON) while phase A input ON (OFF) Count down by 1.

4) 2-phase counter [4 edge-count] (K4, K5)

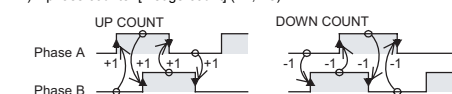

5) 1-phase 2-input counter (K6, K7)



6) 1-phase 1-input counter [Hardware UP/DOWN] (K8, K9)

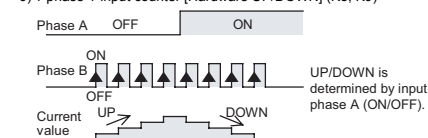

7) 1-phase 1-input counter [Software UP/DOWN] (K10, K11)

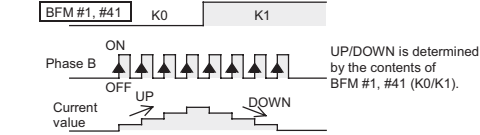

5.2.2 DOWN/UP command [BFM #1 (CH1), #41 (CH2)]

When using the 1-phase 1-input counter [Software UP/DOWN] (counter mode: K10, K11), set the count direction by the current value of BFM #1 or BFM #41. (Default value: K0)

→ For the operation, refer to the Subsection 5.2.1 7)

Count Direction	Setting Value
Up count	K0
Down count	K1

5.2.3 Ring length [BFM #3, #2 (CH1), #43, #42 (CH2)]

When setting the upper limit value of the 16 bit counters, the setting range is K2 to K65536. (Default value: K65536)
Please use the DTO instruction and write data as 32 bit data.
When ring length K100 is specified, the current value of the counter is changed as shown the following figure, and the upper limit value is set to 99.



5.2.4 Command [BFM #4 (CH1), #44 (CH2)]

Bit No.	Setting Value	
	OFF (0)	ON (1)
b0 ¹	Count prohibit	Count permit
b1 ²	YH1 compared output prohibit	YH1 compared output permit
b2 ³	YH2 compared output prohibit	YH2 compared output permit
b3 ⁴	YH1/YH2 independent action	Mutual reset action
b4 ⁵	Preset prohibit	Preset permit
b5 ⁶	No action if PLC is set from RUN to STOP (FX2N-1HC compatibility mode)	Counter is stopped and reset if PLC is set from RUN to STOP
b6, b7	Not used	
b8 ⁷	No action	Error flag reset
b9 ⁸	No action	YH1 output reset
b10 ⁸	No action	YH2 output reset
b11 ⁸	No action	YH1 output set
b12 ⁸	No action	YH2 output set
b13 ~ b15	Not used	

- When b0 is set to ON and the DISABLE input terminal to OFF, the counter is permitted to start counting input pulses.
- Unless b1 is set to ON, YH1 (compared output) does not turn ON.
- Unless b2 is set to ON, YH2 (compared output) does not turn ON.
- When b3=ON, YH2 output is reset if YH1 output is set, and YH1 output is reset if YH2 output is set. When b3=OFF, YH1 and YH2 output act independently, and do not reset each other. The mutual reset action becomes valid only when both the YH1 comparison output and the YH2 comparison output are permitted (b1, b2=ON).
- When b4=OFF, the preset function using the PRESET input terminal is disabled.
- When bit 5 is set to ON, the counter will be stopped and reset and the outputs YH1 and YH2 will be switched OFF when the PLC is set from RUN to STOP.
- When bit 8 in BFM #4 is set to ON, the error flags bit 1 to 6 in BFM #29 will be reset. The shared error flags (bit 7 and bit 8) will also be reset if no error on the other counter channel requires them to remain ON. When bit 8 in BFM #44 is set to ON, the error flags bit 10 to 15 in BFM #29 will be reset. The shared error flags (bit 7 and bit 8) will also be reset if no error on the other counter channel requires them to remain ON. After clearing BFM #29 error flags this flag will be reset automatically.
- b9 to b12 can perform a forced set of the YH1 output or the YH2 output, and reset. The output is not changed when the forced set and reset are performed simultaneously.

5.2.5 Preset data [BFM #11, #10 (CH1), #51, #50 (CH2)]

When BFM #4, #44 b4 is ON and the PRESET input is switched from OFF to ON, preset data is stored in BFM #21, #20 (CH1) #61, #60 (CH2) (counter current value).

5.2.6 YH1 compare value [BFM #13, #12 (CH1), #53, #52 (CH2)], YH2 compare value [BFM #15, #14 (CH1), #55, #54 (CH2)]

- The comparison set value for the output currently written here and the present value of the counter are measured, and when the comparison result is equal, the YH1 output or the YH2 output is set to ON within 30 μs.
- Output occurs when the current value becomes equal to the compare value but only if b1 and b2 of BFM #4, #44 are ON. Once an output is set, it remains ON until it is reset by b9 or b10 of BFM #4, #44.

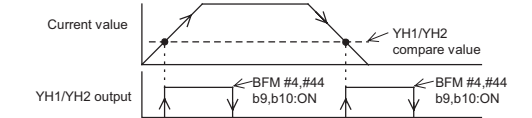

If b3 of BFM #4, #44 is ON, however, one of the outputs is reset when the other is set. (refer to the following figure)

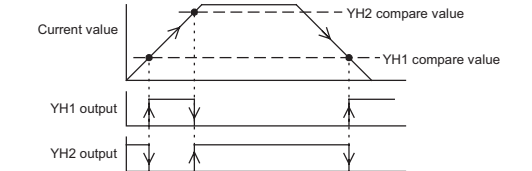

5.2.7 Counter current value [BFM #21, #20 (CH1), #61, #60 (CH2)]

The current value of the counter can be read by the PLC. It will not be an accurate value during high-speed operations because of the communication delay. The current value of the counter can be forcibly changed by writing a 32-bit value into the appropriate BFM from the PLC.

5.2.8 Maximum count value [BFM #23, #22 (CH1), #63, #62 (CH2)], Minimum count value [BFM #25, #24 (CH1), #65, #64 (CH2)]

These BFM store the maximum and minimum value reached by the counter. If the power is turned off, the stored data is cleared. Any value written to maximum and minimum count value in 16 bit counter mode which is exceeding the valid range (0 ≤ value < ring length) will be automatically adjusted. Values < 0 will be adjusted to 0, values ≥ ring length will be adjusted to "ring length" - 1.

5.2.9 Compare results [BFM #26 (CH1), #66 (CH2)]

Bit No.	Target output	OFF (0)	ON (1)
b0		Compare value ≤ current value	Compare value > current value
b1	YH1	Compare value ≠ current value	Compare value = current value
b2		Compare value ≥ current value	Compare value < current value
b3		Compare value ≤ current value	Compare value > current value
b4	YH2	Compare value ≠ current value	Compare value = current value
b5		Compare value ≥ current value	Compare value < current value
b6 ~ b15		Not used	

5.2.10 Terminal status [BFM #27 (CH1), #67 (CH2)]

Bit No.	Signal Name	OFF (0)	ON (1)
b0	PRESET input	OFF	ON
b1	DISABLE input	OFF	ON
b2	YH1 output	OFF	ON
b3	YH2 output	OFF	ON
b4 ~ b15		Not used	

5.2.11 Error status [BFM #29]

Bit No.	Error Status
b0	Set when any of b1 to b15 is ON.
b1	Set when the value of the ring length is written incorrectly. (CH1)
b2	Set when the preset value is written incorrectly. (CH1)

- Outside of K2 to K65,536
- Written while CH1 is in 32-bit counter mode
- Ring length changed while counter running

Value is other than "K0 to ring length-1" for 16-bit counters.

Bit No.	Error Status	
b3	Set when the compare value is written incorrectly. (CH1)	Value is other than "K0 to ring length-1" for 16-bit counters.
b4	Set when the current value is written incorrectly. (CH1)	
b5	Set when the counter overflows the upper limit. (CH1)	When the upper or lower limit is exceeded on a 32-bit counter.
b6	Set when the counter underflows the lower limit. (CH1)	
b7	Set when the FROM/TO command is used incorrectly.*1	
b8	Set when the counter mode (BFM #0, #40) is written incorrectly.	Except K0 to K11
b9	Hardware error (UP, DOWN LED turn ON)	
b10	Set when the value of the ring length is written incorrectly. (CH2)	<ul style="list-style-type: none"> Outside of K2 to K65,536 Written while CH2 is in 32-bit counter mode Ring length changed while counter running
b11	Set when the preset value is written incorrectly. (CH2)	
b12	Set when the compare value is written incorrectly. (CH2)	Value is other than "K0 to ring length-1" for 16-bit counters.
b13	Set when the current value is written incorrectly. (CH2)	
b14	Set when the counter overflows the upper limit. (CH2)	When the upper or lower limit is exceeded on a 32-bit counter.
b15	Set when the counter underflows the lower limit. (CH2)	

- *1 In the following case, BFM #29 b7 turns on.
- write in a BFM that is not used
 - writing to read only BFMs
 - accessing 32 bit BFMs using the FROM/TO command in the wrong order

Error status in the FX3U-2HC can be checked by reading the contents of b0 to b15 of BFM #29 to auxiliary relays of the PLC.

The error flag of b1 to b8 is reset-table with ON of BFM #4 b8. The error flag of b7, b8 and b10 to b15 is resettable with ON of BFM #44 b8. The error flags in BFM #29 can also be reset by writing 0 to it. The Hardware error flag (bit 9 of BFM #29) can not be cleared.

5.2.12 Model identification code [BFM #30]

This BFM stores the identification number for the FX3U-2HC.

The identification number for the FX3U-2HC unit is K4020.

By reading this identification number, the user may create built-in checking routines to check whether the physical position of the FX3U-2HC matches that of the software.

6. Example Program

The ON/OFF status of M10 to M25 is written in BFM #4 (CH1) of special function block No.2 by the following program, and b0 to b15 actions. Among these, b0 to b4 are always ON as controlled by M10-M14. Furthermore, b8 (M18), b9 (M19), and b10 (M20) are controlled by input X004 of the PLC, and X005 by ON/OFF.

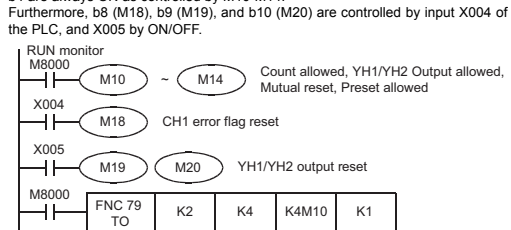

Please use the following program as a guide whenever you use the FX3U-2HC unit. Other instructions to read the current value of the counter, status etc. can be added as required.

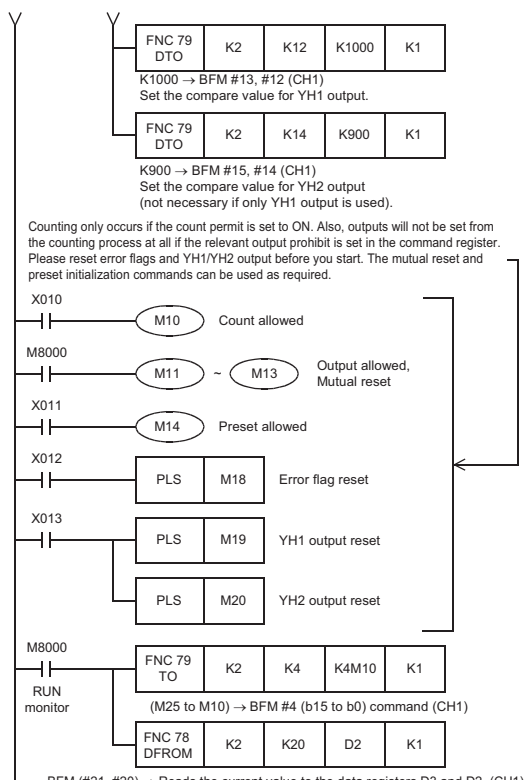
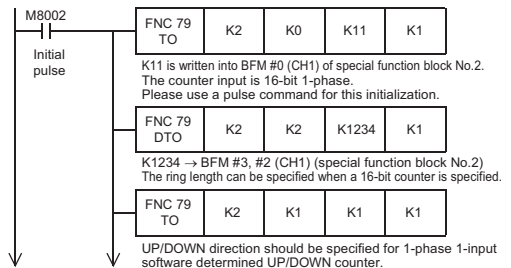

BFM (#21, #20) → Reads the current value to the data registers D3 and D2. (CH1)
 The following programs are the examples of error processing.
 Error status in the FX3U-2HC can be checked by reading the contents of b0 to b15 of BFM #29 to auxiliary relays of the PLC. These error flags are resettable BFM #4, #44 b8.

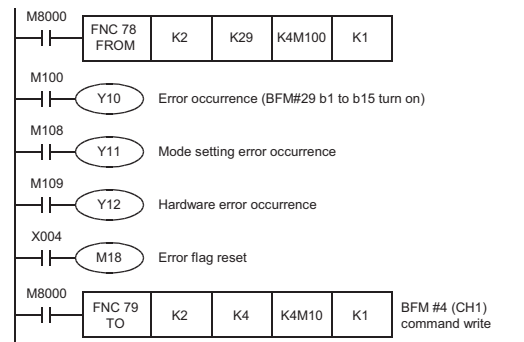

7. Preliminary checks

- 1) Check that the I/O wiring and extension cable of the FX3U-2HC are properly connected.
- 2) The FX3U-2HC occupies 8 points of I/O on the FX3U, FX3UC expansion bus. The 8 points can be allocated from either inputs or outputs. 5V DC 245mA power is supplied from the main or extension power supply units for the FX3U-2HC. Check that there is no power overload from this and other extension blocks.
- 3) The counter works correctly only when data such as the counter mode (set with a pulse command), the TO command, the compare value, etc. are appropriately specified. Remember to initialize the count (BFM #4, #44 b0), preset (BFM #4, #44 b4), and output (BFM #4, #44 b2, b1) prohibits. The YH1/YH2 outputs are reset during start.

Note:
 Inputting pulses higher than the maximum frequency may cause miscounting in the FX3U-2HC or a FROM/TO error in the PLC main unit.

8. Diagnostics

STARTUP AND MAINTENANCE PRECAUTIONS	CAUTION
<ul style="list-style-type: none"> Do not disassemble or modify the PLC. Doing so may cause fire, equipment failures, or malfunctions. <ul style="list-style-type: none"> * For repair, contact your local Mitsubishi Electric distributor. Do not drop the product or exert strong impact to it. Doing so may cause damage. 	
DISPOSAL PRECAUTIONS	CAUTION
<ul style="list-style-type: none"> Please contact a certified electronic waste disposal company for the environmentally safe recycling and disposal of your device. 	
TRANSPORT AND STORAGE PRECAUTIONS	CAUTION
<ul style="list-style-type: none"> The product is a precision instrument. During transportation, avoid any impacts. Failure to do so may cause failures in the product. After transportation, verify the operations of the product. 	

- 1) The following LEDs on the main panel of the FX3U-2HC may help you to troubleshoot the unit.
 - a) ΦA, ΦB: Goes on/off as ΦA, ΦB input turn ON/OFF. It can be checked by rotating the encoder slowly.
 - b) UP, DOWN: Lights up to indicate whether the counter is going up (UP) or down (DOWN).
 - c) PRE, DIS: The appropriate LED lights up when the PRESET (PRE) terminal or the DISABLE (DIS) terminal is ON.
 - d) YH1, YH2: The appropriate LED lights up when YH1/YH2 output is turned on.
- 2) You can check the error status by reading the content of BFM #29 to the PLC. → For error contents, refer to the Subsection 5.2.11

9. Reference (CH1 System Block Diagram)

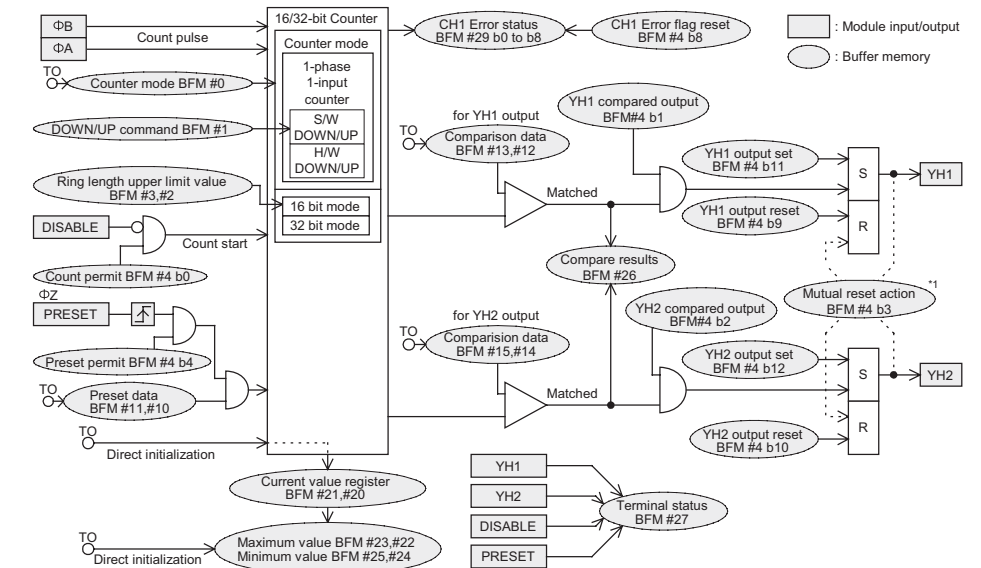

*1 The mutual reset action becomes valid only when both the YH1 comparison output and the YH2 comparison output are permitted (BFM #4 b1, b2=ON).

This manual confers no industrial property rights or any rights of any other kind, nor does it confer any patent licenses. Mitsubishi Electric Corporation cannot be held responsible for any problems involving industrial property rights which may occur as a result of using the contents noted in this manual.

Warranty

Mitsubishi will not be held liable for damage caused by factors found not to be the cause of Mitsubishi; opportunity loss or lost profits caused by faults in the Mitsubishi products; damage, secondary damage, accident compensation caused by special factors unpredictable by Mitsubishi; damages to products other than Mitsubishi products; and to other duties.

For safe use
<ul style="list-style-type: none"> This product has been manufactured as a general-purpose part for general industries, and has not been designed or manufactured to be incorporated in a device or system used in purposes related to human life. Before using the product for special purposes such as nuclear power, electric power, aerospace, medicine or passenger movement vehicles, consult with Mitsubishi Electric. This product has been manufactured under strict quality control. However when installing the product where major accidents or losses could occur if the product fails, install appropriate backup or failsafe functions in the system.



HEAD OFFICE : TOKYO BUILDING, 2-7-3 MARUNOUCHI, CHIYODA-KU, TOKYO 100-8310, JAPAN
 HIMEJI WORKS : 840, CHIYODA CHO, HIMEJI, JAPAN

JY997D36701A

Changes for the Better



PROGRAMMABLE CONTROLLERS
MELSEC-F

FX3U-2HC

USER'S MANUAL

Manual Number	JY997D36701
Revision	A
Date	December 2009



This manual describes the part names, dimensions, mounting, wiring, and specifications of the product. Before use, read this manual and the manuals of all relevant products fully to acquire proficiency in handling and operating the product. Make sure to learn all the product information, safety information, and precautions. Store this manual in a safe place so that it can be taken out and read whenever necessary. Always forward it to the end user.

Registration:
The company and product names described in this manual are registered trademarks or the trademarks of their respective companies.

Effective December 2009
Specifications are subject to change without notice.

© 2009 Mitsubishi Electric Corporation

Safety Precaution (Read these precautions before use.)

This manual classifies the safety precautions into two categories:

⚠ **DANGER** and ⚠ **CAUTION**.

DANGER	Indicates that incorrect handling may cause hazardous conditions, resulting in death or severe injury.
CAUTION	Indicates that incorrect handling may cause hazardous conditions, resulting in medium or slight personal injury or physical damage.

Depending on the circumstances, procedures indicated by **CAUTION** may also cause severe injury. It is important to follow all precautions for personal safety.

Associated Manuals

Manual name	Manual No.	Description
FX3U Series User's Manual - Hardware Edition	JY997D16501 MODEL CODE: 09R516	Explains the FX3U Series PLC specifications for I/O, wiring, installation, and maintenance.
FX3UC Series User's Manual - Hardware Edition	JY997D28701 MODEL CODE: 09R519	Explains the FX3UC Series PLC specifications for I/O, wiring, installation, and maintenance.
FX3G/FX3U/FX3UC Series Programming Manual - Basic & Applied Instruction Edition	JY997D16601 MODEL CODE: 09R517	Describes FX3G/FX3U/FX3UC Series PLC programming for basic/applied instructions and devices.

How to obtain manuals

For product manuals or documents, consult with the Mitsubishi Electric dealer from who you purchased your product.

Certification of UL, cUL standards

The following product has UL and cUL certification.

UL, cUL File Number: E95239

Models: MELSEC FX3U series manufactured

from December 1st, 2009 FX3U-2HC

Compliance with EC directive (CE Marking)

This note does not guarantee that an entire mechanical module produced in accordance with the contents of this note will comply with the following standards. Compliance with EMC directive and LVD directive for the entire mechanical module should be checked by the user / manufacturer. For more details please contact the local Mitsubishi Electric sales site.

Requirement for Compliance with EMC directive

The following products have shown compliance through direct testing (of the identified standards below) and design analysis (through the creation of a technical construction file) to the European Directive for Electromagnetic Compatibility (2004/108/EC) when used as directed by the appropriate documentation.

Attention

- This product is designed for use in industrial applications.
- Manufactured by: Mitsubishi Electric Corporation, 2-7-3 Marunouchi, Chiyoda-ku, Tokyo, 100-8310 Japan
- Manufactured at: Mitsubishi Electric Corporation Himeji Works, 840 Chiyoda-machi, Himeji, Hyogo, 670-8677 Japan
- Authorized Representative in the European Community: Mitsubishi Electric Europe B.V., Gothaer Str. 8, 40880 Ratingen, Germany

Type: Programmable Controller (Open Type Equipment)

Models: MELSEC FX3U series manufactured from December 1st, 2009 FX3U-2HC

Standard	Remark
EN61131-2:2003 Programmable controllers - Equipment requirements and tests	Compliance with all relevant aspects of the standard. EMI • Radiated Emissions • Conducted Emissions EMS • Radiated electromagnetic field • Fast Transient burst • Electrostatic discharge • High-energy surge • Voltage drops and interruptions • Conducted RF • Power frequency magnetic field

Caution for EC Directive

Installation in Enclosure
Programmable logic controllers are open-type devices that must be installed and used within conductive control cabinets. Please use the programmable logic controller while installed within a conductive shielded control cabinet. Please secure the cabinet door to the control cabinet (for conduction). Installation within a control cabinet greatly affects the safety of the system and aids in shielding noise from the programmable logic controller.

1. Outline

1.1 Outline

The hardware high-speed counter block is a 2-channel high-speed counter. It is a special function block for the FX3U and FX3UC series PLC.

1.2 Major Features of the FX3U-2HC

- Differential-Line-Driver (AM26C31 or equivalent) and open collector output encoders are available for the FX3U-2HC.
- The FX3U-2HC has two outputs per channel. When the counter value coincides with an output compare value, the appropriate output is set ON. The output transistors are individually isolated to allow either sink or source connection methods.
- Various counter modes, such as 1-phase or 2-phase, 16-bit or 32-bit modes, can be selected using commands in the sequence program. Allow the FX3U-2HC unit to run only after setting these mode parameters.

1.3 Incorporated Items

Verify that the following product and items are included in the package:

Included Items	Quantity
FX3U-2HC	1 Unit
Special unit/block No. label	1 Sheet
Dust proof protection sheet	1 Sheet
Manuals [Japanese version]	1 manual
Manuals [English version] (This manual)	1 manual

1.4 External Dimensions, Part Names, and Terminal Layout

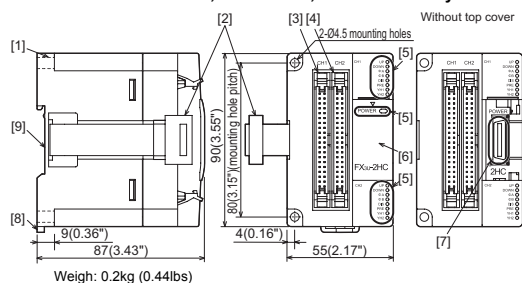

No.	Name
[1]	Direct mounting hole: 2 holes of $\phi 4.5$ (0.18") (mounting screw: M4 screw) Used when attaching FX3U-2HC directly.
[2]	Extension cable (PLC side) Used to connect this special function block to the FX3U/FX3UC main unit or an extension block.
[3]	CH1 connector
[4]	CH2 connector
Status LED (the upper side: CH1, the lower side: CH2)	
POWER (Green)	Power LED ON when the 5V power supply is normally supplied from the PLC.
UP (Red)	Up count LED The respective LED is ON according to up/down count direction of the counter.
DOWN (Red)	Down count LED
ϕA (Red)	A phase input LED The respective LED is ON (flicker) according to ON/OFF of ϕA and ϕB input.
ϕB (Red)	B phase input LED
DIS (Red)	DISABLE input LED The respective LED is ON/OFF according to ON/OFF of PRESET and DISABLE input.
PRE (Red)	PRESET input LED
YH1 (Red)	YH1 output LED The respective LED is ON/OFF according to status of YH1 and YH2 output.
YH2 (Red)	YH2 output LED
[6]	Top cover
[7]	Extension connector (Extension side) Used to connect a FX3U extension block to the right of this special function block. Remove top cover for connecting.
[8]	DIN rail mounting hook
[9]	DIN rail mounting groove (DIN rail: DIN46277, 35mm (1.38") width)

FX3U-2HC connector arrangement

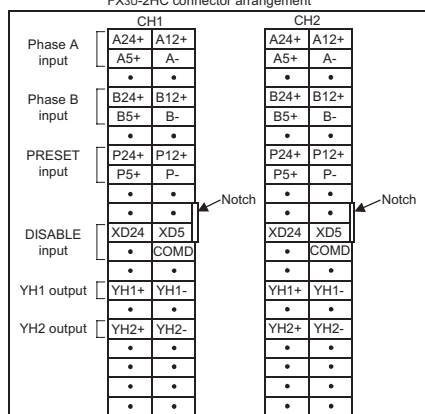

2. Installation, Connect to the PLC

INSTALLATION PRECAUTIONS	DANGER
<ul style="list-style-type: none"> Make sure to cut off all phases of the power supply externally before attempting installation or wiring work. Failure to do so may cause electric shock or damage to the product. 	
INSTALLATION PRECAUTIONS	CAUTION
<ul style="list-style-type: none"> Use the product within the generic environment specifications described in PLC main unit manual. Never use the product in areas with excessive dust, oily smoke, conductive dusts, corrosive gas (salt air, Cl₂, H₂S, SO₂, or NO₂), flammable gas, vibration or impacts, or expose it to high temperature, condensation, or rain and wind. If the product is used in such conditions, electric shock, fire, malfunctions, deterioration or damage may occur. Do not touch the conductive parts of the product directly. Doing so may cause device failures or malfunctions. Install the product on a flat surface. If the mounting surface is rough, undue force will be applied to the PC board, thereby causing nonconformities. When drilling screw holes or wiring, make sure cutting or wire debris does not enter the ventilation slits. Failure to do so may cause fire, equipment failures or malfunctions. Be sure to remove the dust proof sheet from the PLC's ventilation port when installation work is completed. Failure to do so may cause fire, equipment failures or malfunctions. Connect extension cables securely to their designated connectors. Loose connections may cause malfunctions. 	

2.1 Mounting

The product is mounted by the following method.

- DIN rail mounting
 - Direct mounting (mounting screw: M4 screw)
- For further information on installation arrangements, refer to the following manuals.
→ Refer to the FX3U Series User's Manual - Hardware Edition.
→ Refer to the FX3UC Series User's Manual - Hardware Edition.

2.1.1 DIN Rail Mounting

The product can be mounted on a DIN rail (DIN46277, 35mm (1.38") width).

- Fit the upper edge of the DIN rail mounting groove (fig. A) onto the DIN rail.
- Press the product against the DIN rail.
 - An interval space of 1 to 2 mm (0.04" to 0.08") between each unit is necessary.

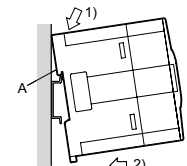

2.1.2 Direct Mounting (mounting screw: M4 screw)

The product can be installed directly with screws. Refer to the External Dimensions (section 1.4) for the product's mounting hole pitch information.

An interval space between each unit of 1 to 2 mm (0.04" to 0.08") is necessary.

2.2 Connection to the PLC

A maximum of eight¹ FX3U-2HC(s) are connectable with the main unit or the right side of the powered extension unit/block. A unit number of No.0 to No.7 is assigned based on the order in which special function units/blocks are attached to the main unit.

For connection to an FX3UC Series PLC or FX2NC Series PLC extension block, an FX2NC-CNV-IF or FX3UC-1PS-5V is required.

¹ Up to seven special function units/blocks in total can be connected to the FX3UC-32MT-LT(-2) PLC. Unit numbers assigned to special function units/blocks begins with No.1.

For further information on installation arrangements, refer to the following manuals.
→ Refer to the FX3U Series User's Manual - Hardware Edition.
→ Refer to the FX3UC Series User's Manual - Hardware Edition.

3. Wiring (Power supply and analog input)

WIRING PRECAUTIONS	DANGER
<ul style="list-style-type: none"> Make sure to cut off all phases of the power supply externally before attempting installation or wiring work. Failure to do so may cause electric shock or damage to the product. 	

WIRING PRECAUTIONS	CAUTION
<ul style="list-style-type: none"> When drilling screw holes or wiring, make sure cutting or wire debris does not enter the ventilation slits. Failure to do so may cause fire, equipment failures or malfunctions. Make sure to observe the following precautions in order to prevent any damage to the machinery or accidents due to abnormal data written to the PLC under the influence of noise: <ol style="list-style-type: none"> Do not bundle the main circuit line together with or lay it close to the main circuit, high-voltage line or load line. Otherwise, noise disturbance and/or surge induction are likely to take place. As a guideline, lay the control line at least 100mm (3.94") or more away from the main circuit or high-voltage lines. Ground the shield wire or shield of the shielded cable at two points; on the PLC and the device on other end. However, do not use common grounding with heavy electrical systems. 	

3.1 Connection to input/output connector

The input and output connectors conform to the MIL-C-83503.

→ For the input and output connectors pin assignment, refer to section 1.4.

- Compliant connectors (commercially available connectors)
 - Use a 40-pin (1-key) socket connector conforming to MIL-C-83503.
 - Confirm in advance that the connectors do not interfere with other parts including connector covers.
- Connectors for user-made input/output cables (available from Mitsubishi)
 - Users should provide electric wires and a pressure bonding tool.

Model name and composition of input/output connector	Applicable electric wire (UL-1061 are recommended) and tool												
<table border="1" style="width: 100%; border-collapse: collapse;"> <tr> <th>Our model name</th> <th>Details of part (made by DDK Ltd.)</th> <th>Electric wire size</th> <th>Pressure bonding tool (made by DDK Ltd.)</th> </tr> <tr> <td>FX-I/O-CO2-S for bulk wire (2-piece set)</td> <td>Housing:HU-400S2-001 Solderless contact: HU-411S</td> <td>AWG22 (0.3mm²)</td> <td>357J-5538</td> </tr> <tr> <td>FX-I/O-CO2-SA for bulk wire (2-piece set)</td> <td>Housing:HU-400S2-001 Solderless contact: HU-411SA</td> <td>AWG20 (0.5mm²)</td> <td>357J-13963</td> </tr> </table>	Our model name	Details of part (made by DDK Ltd.)	Electric wire size	Pressure bonding tool (made by DDK Ltd.)	FX-I/O-CO2-S for bulk wire (2-piece set)	Housing:HU-400S2-001 Solderless contact: HU-411S	AWG22 (0.3mm ²)	357J-5538	FX-I/O-CO2-SA for bulk wire (2-piece set)	Housing:HU-400S2-001 Solderless contact: HU-411SA	AWG20 (0.5mm ²)	357J-13963	
Our model name	Details of part (made by DDK Ltd.)	Electric wire size	Pressure bonding tool (made by DDK Ltd.)										
FX-I/O-CO2-S for bulk wire (2-piece set)	Housing:HU-400S2-001 Solderless contact: HU-411S	AWG22 (0.3mm ²)	357J-5538										
FX-I/O-CO2-SA for bulk wire (2-piece set)	Housing:HU-400S2-001 Solderless contact: HU-411SA	AWG20 (0.5mm ²)	357J-13963										

3.2 Wiring

Note:
Make sure to properly wire in accordance with the encoder output specifications. Incorrect wiring may cause accidents or damage to the product.

3.2.1 NPN output encoders

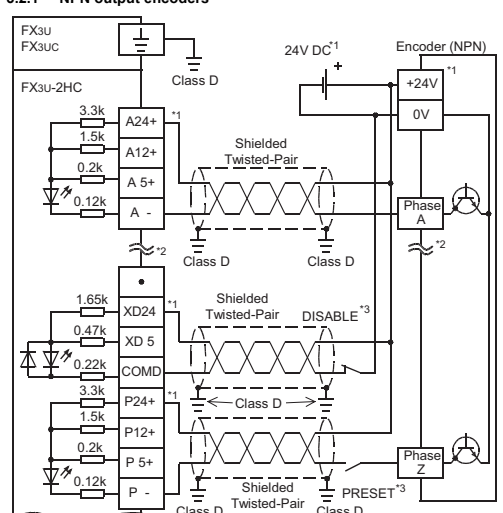

- Drive power supply of the encoder. Use either 24V DC, 12V DC, or 5V DC according to the encoder type. When connecting the A phase, the B phase, and the Z phase to the FX3U-2HC, connect to the power supply terminal. When using 24V DC for PRESET or DISABLE signals, connect to the 24V DC (P24+, XD24) terminal.
- Wiring of the B phase is the same as that of the A phase.
- This wiring is unnecessary when not using the PRESET function or the DISABLE function.

3.2.2 PNP output encoders

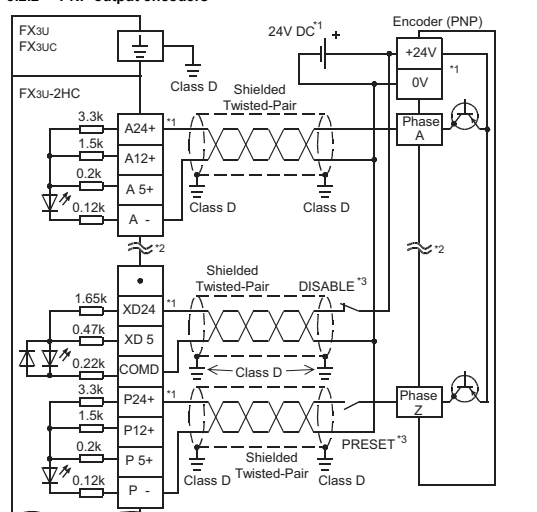

- Drive power supply of the encoder. Use either 24V DC, 12V DC, or 5V DC according to the encoder type. When connecting the A phase, the B phase, and the Z phase to the FX3U-2HC, connect to the power supply terminal. When using 24V DC for PRESET or DISABLE signals, connect to the 24V DC (P24+, XD24) terminal.
- Wiring of the B phase is the same as that of the A phase.
- This wiring is unnecessary when not using the PRESET function or the DISABLE function.

3.2.3 Differential-Line-Driver output encoders

When applying the Differential-Line-Driver encoder (AM26C31 or equivalent) to the FX3U-2HC, connect the encoder output with the 5V DC terminal as shown in the figure below.

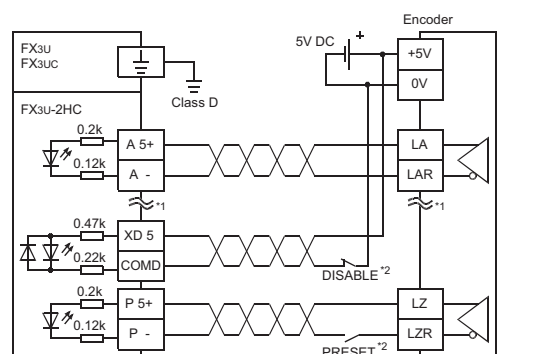

- Wiring of the B phase is the same as that of the A phase.
- This wiring is unnecessary when not using the PRESET function or the DISABLE function.

3.2.4 YH1, YH2 output wiring (Sink wiring)

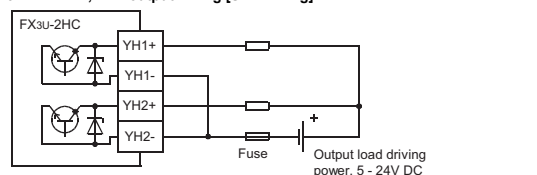

- Drive power supply of the encoder. Use either 24V DC, 12V DC, or 5V DC according to the encoder type. When connecting the A phase, the B phase, and the Z phase to the FX3U-2HC, connect to the power supply terminal. When using 24V DC for PRESET or DISABLE signals, connect to the 24V DC (P24+, XD24) terminal.
- Wiring of the B phase is the same as that of the A phase.
- This wiring is unnecessary when not using the PRESET function or the DISABLE function.

3.2.5 YH1, YH2 output wiring [Source wiring]

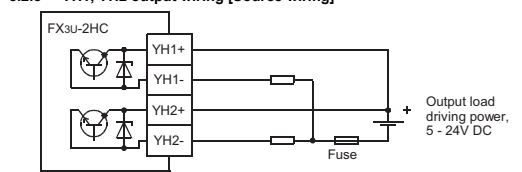

Caution
A protection fuse should be inserted at the output. Use a load power supply capacity that is at least 2 times larger than the total rated fuse capacity.

3.3 Grounding

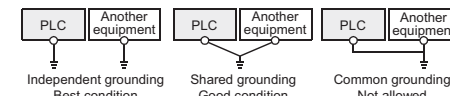
- Grounding should be performed as stated below.
- The grounding resistance should be 100 Ω or less.
 - Independent grounding should be performed for best results. When independent grounding is not performed, perform "shared grounding" of the following figure.
- For details, refer to the FX3U Series User's Manual - Hardware Edition.
→ For details, refer to the FX3UC Series User's Manual - Hardware Edition.
- 
- The grounding wire size should be AWG 22-20 (0.3-0.5 mm²).
 - The grounding point should be close to the PLC, and all grounding wires should be as short as possible.

4. Specifications

DESIGN PRECAUTIONS	DANGER
<ul style="list-style-type: none"> Make sure to have the following safety circuits outside of the PLC to ensure safe system operation even during external power supply problems or PLC failure. Otherwise, malfunctions may cause serious accidents. <ol style="list-style-type: none"> Most importantly, have the following: an emergency stop circuit, a protection circuit, an interlock circuit for opposite movements (such as normal vs. reverse rotation), and an interlock circuit (to prevent damage to the equipment at the upper and lower positioning limits). Note that when the PLC CPU detects an error, such as a watchdog timer error, during self-diagnosis, all outputs are turned off. Also, when an error that cannot be detected by the PLC CPU occurs in an input/output control block, output control may be disabled. External circuits and mechanisms should be designed to ensure safe machinery operation in such a case. Note that when an error occurs in a relay, triac or transistor output device, the output could be held either on or off. For output signals that may lead to serious accidents, external circuits and mechanisms should be designed to ensure safe machinery operation in such a case. 	
DESIGN PRECAUTIONS	CAUTION
<ul style="list-style-type: none"> Do not bundle the control line together with or lay it close to the main circuit or power line. As a guideline, lay the control line at least 100mm (3.94") or more away from the main circuit or power line. Noise may cause malfunctions. Install module so that excessive force will not be applied to I/O connectors. Failure to do so may result in wire damage/breakage or PLC failure. 	

4.1 General Specifications

The general specifications are equivalent to the PLC main unit. (For general specifications, refer to the manual of the PLC main unit.)

4.2 Power Supply Specifications

When a dielectric withstand test of this product is performed, ground all terminals of this product and the PLC unit.

5. Buffer Memories (BFM)

5.1 Buffer memory List

- Note:**
- When writing to BFM #0 (CH1 counter mode), BFM #1 to #27 and #29 bit 1 to 6 will be initialized. When writing to BFM #40 (CH2 counter mode), BFM #41 to #67 and #29 bit 10 to 15 will be initialized. Please perform the setting of other BFM(s) after the setting of the counter mode (BFM #0, #40). When setting the counter mode, use a TOP (pulsed) instruction, or M8002 (initial pulse) to drive the TO instruction. (The continuous operation type cannot be used.)
 - Read/Write of 16 bit data
When using a positive value between K32,768 and K65,535 with 16 bit counters, read/writes of data, such as the current value, ring length, preset data, YH1/YH2 compare value, maximum count value and the minimum count value should use the 32-bit forms of FROM/TO instructions (D) FROM, (D) TO.
 - Read/write of 32 bit data
The usage of a 32-bit FROM/TO instruction is recommended. In the event that a 16-bit FROM/TO instruction is used, the following cases need to be considered.
 - If the writing order is low word first and then high word, the 32 bit data will be written normally. Data becomes valid after both low and high words are written.
 - In the event that data is not written in the order low word first and then high word, the error bit b7 of BFM #29 turns ON.

BFM #		Description	Default	BFM Access
CH1	CH2			
BFM #0	BFM #40	Counter mode (Setting range: K0 to K11)	K0	R/W
BFM #1	BFM #41	DOWN/UP command (1-phase 1-input mode [S/W UP/DOWN] only)	K0	R/W
BFM #2	BFM #42	Ring length	Lower	R/W
BFM #3	BFM #43		Upper	
BFM #4	BFM #44	Command	K0	R/W
BFM #5	BFM #45	Not used	-	-
BFM #6	BFM #46			
BFM #10	BFM #50	Preset data	Lower	R/W
BFM #11	BFM #51		Upper	
BFM #12	BFM #52	YH1 compare value	Lower	R/W
BFM #13	BFM #53		Upper	
BFM #14	BFM #54	YH2 compare value	Lower	R/W
BFM #15	BFM #55		Upper	
BFM #16	BFM #56	Not used	-	-
BFM #17	BFM #57			
BFM #20	BFM #60	Counter current value	Lower	R/W
BFM #21	BFM #61		Upper	
BFM #22	BFM #62	Maximum count value	Lower	R/W
BFM #23	BFM #63		Upper	
BFM #24	BFM #64	Minimum count value	Lower	R/W
BFM #25	BFM #65		Upper	
BFM #26	BFM #66	Compare results	-	R
BFM #27	BFM #67	Terminal status	-	R
BFM #28		Not used	-	-
BFM #29		Error status	-	R
BFM #30		Model identification code: K4020	K4020	R
BFM #31 ~ 39		Not used	-	-
BFM #68 ~ 32767		Not used	-	-

5.2 Details of buffer memories

5.2.1 Counter mode [BFM #0 (CH1), #40 (CH2)]

The counter mode is shown in the upper right table. (Default value: K0)

Note:
When writing to BFM #0 (CH1 counter mode), BFM #1 to #27 and #29 bit 1 to 6 will be initialized. When writing to BFM #40 (CH2 counter mode), BFM #41 to #67 and #29 bit 10 to 15 will be initialized. Please perform the setting of other BFM(s) after the setting of the counter mode (BFM #0, #40). When setting the counter mode, use a TOP (pulsed) instruction, or M8002 (initial pulse) to drive the TO instruction. (The continuous operation type cannot be used.)

Count modes	32 bits	16 bits	Reference	
2-phase input (phase difference pulse)	1 edge count	K0	K1	(1), (2)
	2 edge count	K2	K3	(1), (3)
	4 edge count	K4	K5	(1), (4)
1-phase 2-input (add/subtract pulse)		K6	K7	(1), (5)
1-phase 1-input	Hardware UP/DOWN	K8	K9	(1), (6)
	Software UP/DOWN	K10	K11	(1), (7)

- 16/32-bit counter modes
 - 32-bit counter modes
Modes: K0, K2, K4, K6, K8, K10
A 32-bit binary counter which executes UP/DOWN counting will change from the lower limit value to the upper limit value or the upper limit value to the lower limit value when overflow occurs. Both the upper and lower limit values are fixed values: the upper limit value is +2,147,483,647, and the lower limit value is -2,147,483,648.
 - 16-bit counter modes
Modes: K1, K3, K5, K7, K9, K11
A 16-bit binary counter handles only positive values from 0 to 65,535. Changes to zero from the upper limit value or to the upper limit value from zero when overflow occurs; the upper limit value is determined by BFM #3 and #2 (CH1), #43 and #42 (CH2).

2) 2-phase counter [1 edge-count] (K0, K1)

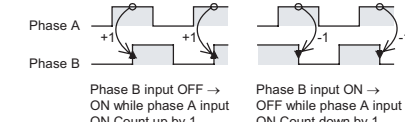

3) 2-phase counter [2 edge-count] (K2, K3)

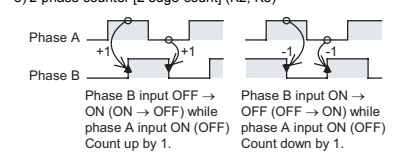

4) 2-phase counter [4 edge-count] (K4, K5)

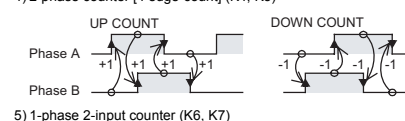

5) 1-phase 2-input counter (K6, K7)



6) 1-phase 1-input counter [Hardware UP/DOWN] (K8, K9)

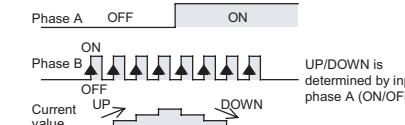

7) 1-phase 1-input counter [Software UP/DOWN] (K10, K11)

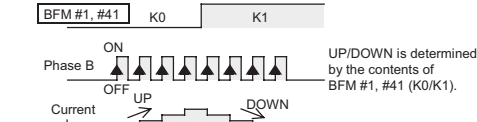

5.2.2 DOWN/UP command [BFM #1 (CH1), #41 (CH2)]

When using the 1-phase 1-input counter [Software UP/DOWN] (counter mode: K10, K11), set the count direction by the current value of BFM #1 or BFM #41. (Default value: K0)

→ For the operation, refer to the Subsection 5.2.1.7

Count Direction	Setting Value
Up count	K0
Down count	K1

5.2.3 Ring length [BFM #3, #2 (CH1), #43, #42 (CH2)]

When setting the upper limit value of the 16 bit counters, the setting range is K2 to K65536. (Default value: K65536)
Please use the DTO instruction and write data as 32 bit data.
When ring length K100 is specified, the current value of the counter is changed as shown the following figure, and the upper limit value is set to 99.

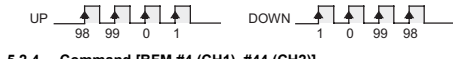

5.2.4 Command [BFM #4 (CH1), #44 (CH2)]

Bit No.	Setting Value	
	OFF (0)	ON (1)
b0 ¹	Count prohibit	Count permit
b1 ²	YH1 compared output prohibit	YH1 compared output permit
b2 ³	YH2 compared output prohibit	YH2 compared output permit
b3 ⁴	YH1/YH2 independent action	Mutual reset action
b4 ⁵	Preset prohibit	Preset permit
b5 ⁶	No action if PLC is set from RUN to STOP (FX2N-1HC compatibility mode)	Counter is stopped and reset if PLC is set from RUN to STOP
b6, b7	Not used	
b8 ⁷	No action	Error flag reset
b9 ⁸	No action	YH1 output reset
b10 ⁸	No action	YH2 output reset
b11 ⁸	No action	YH1 output set
b12 ⁸	No action	YH2 output set
b13 ~ b15	Not used	

- When b0 is set to ON and the DISABLE input terminal to OFF, the counter is permitted to start counting input pulses.
- Unless b1 is set to ON, YH1 (compared output) does not turn ON.
- Unless b2 is set to ON, YH2 (compared output) does not turn ON.
- When b3=ON, YH2 output is reset if YH1 output is set, and YH1 output is reset if YH2 output is set. When b3=OFF, YH1 and YH2 output act independently, and do not reset each other. The mutual reset action becomes valid only when both the YH1 comparison output and the YH2 comparison output are permitted (b1, b2=ON).
- When b4=OFF, the preset function using the PRESET input terminal is disabled.
- When bit 5 is set to ON, the counter will be switched OFF when the PLC is set from RUN to STOP.
- When bit 8 in BFM #4 is set to ON, the error flags bit 1 to 6 in BFM #29 will be reset. The shared error flags (bit 7 and bit 8) will also be reset if no error on the other counter channel requires them to remain ON. When bit 8 in BFM #44 is set to ON, the error flags bit 10 to 15 in BFM #29 will be reset. The shared error flags (bit 7 and bit 8) will also be reset if no error on the other counter channel requires them to remain ON. After clearing BFM #29 error flags this flag will be reset automatically.
- b9 to b12 can perform a forced set of the YH1 output or the YH2 output, and reset. The output is not changed when the forced set and reset are performed simultaneously.

5.2.5 Preset data [BFM #11, #10 (CH1), #51, #50 (CH2)]

When BFM #4, #44 b4 is ON and the PRESET input is switched from OFF to ON, preset data is stored in BFM #21, #20 (CH1) #61, #60 (CH2) (counter current value).

5.2.6 YH1 compare value [BFM #13, #12 (CH1), #53, #52 (CH2)], YH2 compare value [BFM #15, #14 (CH1), #55, #54 (CH2)]

- The comparison set value for the output currently written here and the present value of the counter are measured, and when the comparison result is equal, the YH1 output or the YH2 output is set to ON within 30 μs.
- Output occurs when the current value becomes equal to the compare value but only if b1 and b2 of BFM #4, #44 are ON. Once an output is set, it remains ON until it is reset by b9 or b10 of BFM #4, #44.

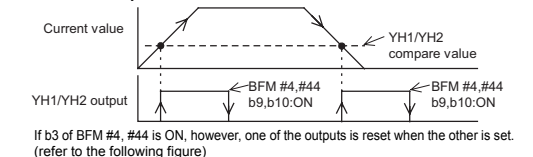

If b3 of BFM #4, #44 is ON, however, one of the outputs is reset when the other is set (refer to the following figure)

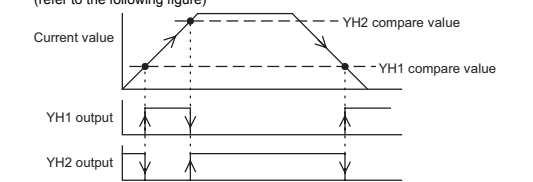

5.2.7 Counter current value [BFM #21, #20 (CH1), #61, #60 (CH2)]

The current value of the counter can be read by the PLC. It will not be an accurate value during high-speed operations because of the communication delay. The current value of the counter can be forcibly changed by writing a 32-bit value into the appropriate BFM from the PLC.

5.2.8 Maximum count value [BFM #23, #22 (CH1), #63, #62 (CH2)], Minimum count value [BFM #25, #24 (CH1), #65, #64 (CH2)]

These BFM store the maximum and minimum value reached by the counter. If the power is turned off, the stored data is cleared. Any value written to maximum and minimum count value in 16 bit counter mode which is exceeding the valid range (0 <= value < ring length) will be automatically adjusted. Values < 0 will be adjusted to 0, values >= ring length will be adjusted to "ring length" - 1.

5.2.9 Compare results [BFM #26 (CH1), #66 (CH2)]

Bit No.	Target output	OFF (0)	ON (1)
b0	YH1	Compare value <= current value	Compare value > current value
b1		Compare value <= current value	Compare value > current value
b2		Compare value <= current value	Compare value > current value
b3	YH2	Compare value <= current value	Compare value > current value
b4		Compare value <= current value	Compare value > current value
b5		Compare value <= current value	Compare value > current value
b6 ~ b15	Not used		

5.2.10 Terminal status [BFM #27 (CH1), #67 (CH2)]

Bit No.	Signal Name	OFF (0)	ON (1)
b0	PRESET input	OFF	ON
b1	DISABLE input	OFF	ON
b2	YH1 output	OFF	ON
b3	YH2 output	OFF	ON
b4 ~ b15	Not used		

5.2.11 Error status [BFM #29]

Bit No.	Error Status	
b0	Set when any of b1 to b15 is ON.	
b1	Set when the value of the ring length is written incorrectly. (CH1)	<ul style="list-style-type: none"> Outside of K2 to K65,536 Written while CH1 is in 32-bit counter mode Ring length changed while counter running
b2	Set when the preset value is written incorrectly. (CH1)	Value is other than "K0 to ring length-1" for 16-bit counters.

Bit No.	Error Status	
b3	Set when the compare value is written incorrectly. (CH1)	Value is other than "K0 to ring length-1" for 16-bit counters.
b4	Set when the current value is written incorrectly. (CH1)	
b5	Set when the counter overflows the upper limit. (CH1)	When the upper or lower limit is exceeded on a 32-bit counter.
b6	Set when the counter underflows the lower limit. (CH1)	
b7	Set when the FROM/TO command is used incorrectly. ¹	
b8	Set when the counter mode (BFM #0, #40) is written incorrectly.	Except K0 to K11
b9	Hardware error (UP, DOWN LED turn ON)	
b10	Set when the value of the ring length is written incorrectly. (CH2)	<ul style="list-style-type: none"> Outside of K2 to K65,536 Written while CH2 is in 32-bit counter mode Ring length changed while counter running
b11	Set when the preset value is written incorrectly. (CH2)	
b12	Set when the compare value is written incorrectly. (CH2)	Value is other than "K0 to ring length-1" for 16-bit counters.
b13	Set when the current value is written incorrectly. (CH2)	
b14	Set when the counter overflows the upper limit. (CH2)	When the upper or lower limit is exceeded on a 32-bit counter.
b15	Set when the counter underflows the lower limit. (CH2)	

- ¹ In the following case, BFM #29 b7 turns on.
- write in a BFM that is not used
 - writing to read only BFMs
 - accessing 32 bit BFMs using the FROM/TO command in the wrong order

Error status in the FX3U-2HC can be checked by reading the contents of b0 to b15 of BFM #29 to auxiliary relays of the PLC. The error flag of b1 to b8 is reset-table with ON of BFM #4 b8. The error flag of b7, b8 and b10 to b15 is resettable with ON of BFM #44 b8. The error flags in BFM #29 can also be reset by writing 0 to it. The Hardware error flag (bit 9 of BFM #29) can not be cleared.

5.2.12 Model identification code [BFM #30]

This BFM stores the identification number for the FX3U-2HC. The identification number for the FX3U-2HC unit is K4020. By reading this identification number, the user may create built-in checking routines to check whether the physical position of the FX3U-2HC matches that of the software.

6. Example Program

The ON/OFF status of M10 to M25 is written in BFM #4 (CH1) of special function block No.2 by the following program, and b0 to b15 actions. Among these, b0 to b4 are always ON as controlled by M10-M14. Furthermore, b8 (M18), b9 (M19), and b10 (M20) are controlled by input X004 of the PLC, and X005 by ON/OFF.

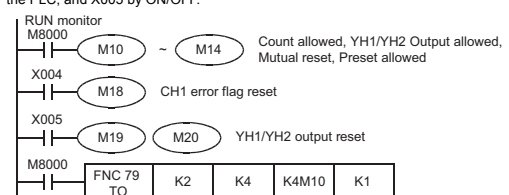

Please use the following program as a guide whenever you use the FX3U-2HC unit. Other instructions to read the current value of the counter, status etc. can be added as required.

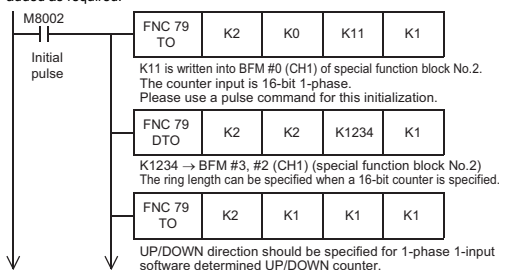

The following programs are the examples of error processing. Error status in the FX3U-2HC can be checked by reading the contents of b0 to b15 of BFM #29 to auxiliary relays of the PLC. These error flags are resettable BFM #4, #44 b8.

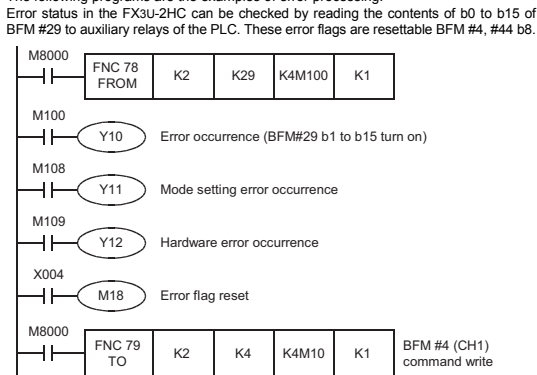

7. Preliminary checks

- Check that the I/O wiring and extension cable of the FX3U-2HC are properly connected.
- The FX3U-2HC occupies 8 points of I/O on the FX3U, FX3UC expansion bus. The 8 points can be allocated from either inputs or outputs. 5V DC 245mA power is supplied from the main or extension power supply units for the FX3U-2HC. Check that there is no power overload from this and other extension blocks.
- The counter works correctly only when data such as the counter mode (set with a pulse command), the TO command, the compare value, etc. are appropriately specified. Remember to initialize the count (BFM #4, #44 b0), preset (BFM #4, #44 b4), and output (BFM #4, #44 b2, b1) prohibits. The YH1/YH2 outputs are reset during start.

Note:
Inputting pulses higher than the maximum frequency may cause miscounting in the FX3U-2HC or a FROM/TO error in the PLC main unit.

8. Diagnostics

STARTUP AND MAINTENANCE PRECAUTIONS **CAUTION**

- Do not disassemble or modify the PLC.
- Doing so may cause fire, equipment failures, or malfunctions.
- * For repair, contact your local Mitsubishi Electric distributor.
- Do not drop the product or exert strong impact to it. Doing so may cause damage.

DISPOSAL PRECAUTIONS **CAUTION**

- Please contact a certified electronic waste disposal company for the environmentally safe recycling and disposal of your device.

TRANSPORT AND STORAGE PRECAUTIONS **CAUTION**

- The product is a precision instrument. During transportation, avoid any impacts. Failure to do so may cause failures in the product. After transportation, verify the operations of the product.

- The following LEDs on the main panel of the FX3U-2HC may help you to troubleshoot the unit.
 - ΦA, ΦB:
Goes on/off as ΦA, ΦB input turn ON/OFF. It can be checked by rotating the encoder slowly.
 - UP, DOWN:
Lights up to indicate whether the counter is going up (UP) or down (DOWN).
 - PRE, DIS:
The appropriate LED lights up when the PRESET (PRE) terminal or the DISABLE (DIS) terminal is ON.
 - YH1, YH2:
The appropriate LED lights up when YH1/YH2 output is turned on.
- You can check the error status by reading the content of BFM #29 to the PLC.
→ For error contents, refer to the Subsection 5.2.11

9. Reference (CH1 System Block Diagram)

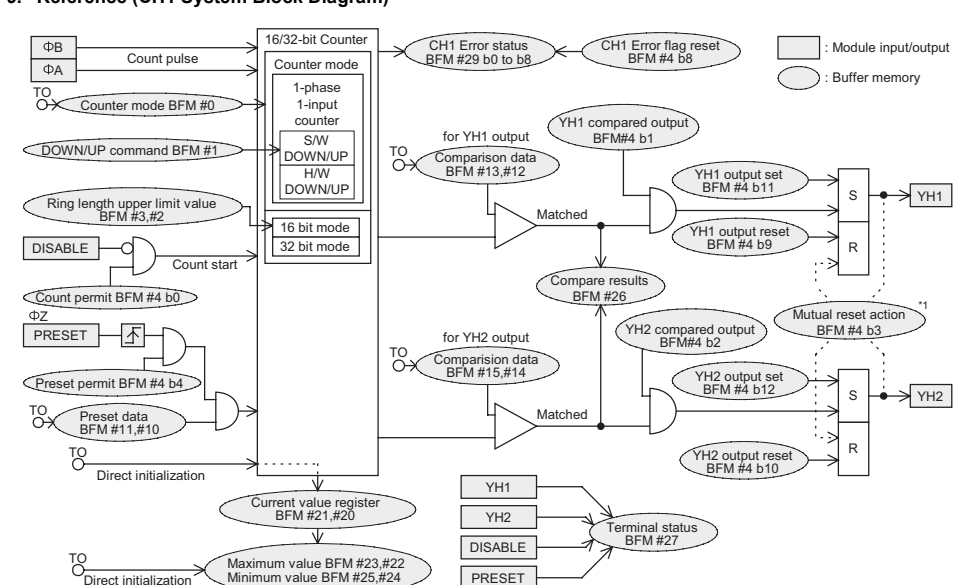

¹ The mutual reset action becomes valid only when both the YH1 comparison output and the YH2 comparison output are permitted (BFM #4 b1, b2=ON).

This manual confers no industrial property rights or any rights of any other kind, nor does it confer any patent licenses. Mitsubishi Electric Corporation cannot be held responsible for any problems involving industrial property rights which may occur as a result of using the contents noted in this manual.

Warranty
Mitsubishi will not be held liable for damage caused by factors found not to be the cause of Mitsubishi; opportunity loss or lost profits caused by faults in the Mitsubishi products; damage, secondary damage, accident compensation caused by special factors unpredictable by Mitsubishi; damages to products other than Mitsubishi products; and to other duties.

For safe use

- This product has been manufactured as a general-purpose part for general industries, and has not been designed or manufactured to be incorporated in a device or system used in purposes related to human life.
- Before using the product for special purposes such as nuclear power, electric power, aerospace, medicine or passenger movement vehicles, consult with Mitsubishi Electric.
- This product has been manufactured under strict quality control. However when installing the product where major accidents or losses could occur if the product fails, install appropriate backup or failsafe functions in the system.

MITSUBISHI ELECTRIC CORPORATION

HEAD OFFICE : TOKYO BUILDING, 2-7-3 MARUNOUCHI, CHIYODA-KU, TOKYO 100-8310, JAPAN
HIMEJI WORKS : 840, CHIYODA CHO, HIMEJI, JAPAN