

FX2N

FX2N-10GM

USER'S GUIDE

JY992D77701E

This manual only describes the specifications for FX2N-10GM positioning controller.

For complete operation, wiring, mounting and programming instructions please refer to the FX2N-10GM, FX2N-20GM HARDWARE PROGRAMMING MANUAL, FX PROGRAMMING MANUAL II and FX SERIES HARDWARE MANUAL.

These manuals should be read and understood before attempting to install or use the unit.

And, store this manual in a safe place so that you can take it out and read it whenever necessary. Always forward it to the end user.

Safety Precaution (Read these precautions before use.)

This manual classifies the safety precautions into two categories: **DANGER** and **CAUTION**.

DANGER	Indicates that incorrect handling may cause hazardous conditions, resulting in death or severe injury.
CAUTION	Indicates that incorrect handling may cause hazardous conditions, resulting in medium or slight personal injury or physical damage.

Depending on the circumstances, procedures indicated by **CAUTION** may also cause severe injury. It is important to follow all precautions for personal safety

DESIGN PRECAUTIONS	DANGER
<ul style="list-style-type: none"> Install a safety circuit outside the PLC so that the entire system conservatively operates even if an abnormality occurs in the external power supply or a failure occurs in the PLC. If the safety circuit is installed inside the PLC, malfunction and erroneous output may cause accidents. 	

STARTUP AND MAINTENANCE PRECAUTIONS	DANGER
<ul style="list-style-type: none"> Do not touch any terminal while the FX2N-10GM positioning controller's power is on. Doing so may cause electric shock or malfunctions. Before cleaning or retightening terminals externally cut off all phases of the power supply. Failure to do so may cause electric shock. Thoroughly read the manual, sufficiently confirming safety, then perform returning to the zero point in the MANU/AUTO mode, jog operation, step operation or automatic operation. An operation error may damage the machinery or cause accidents. 	

STARTUP AND MAINTENANCE PRECAUTIONS	CAUTION
<ul style="list-style-type: none"> Do not disassemble or modify the FX2N-10GM positioning controller. Doing so may cause fire, equipment failures, or malfunctions. For repair, contact your local Mitsubishi Electric distributor. Turn off the power to the FX2N-10GM positioning controller before connecting or disconnecting any extension cable. Failure to do so may cause equipment failures or malfunctions. Turn off the power to the FX2N-10GM positioning controller before attaching or detaching the following devices. Failure to do so may cause equipment failures or malfunctions. <ul style="list-style-type: none"> Peripheral devices, FX Series terminal blocks 	

DISPOSAL PRECAUTIONS	CAUTION
<ul style="list-style-type: none"> Please contact a certified electronic waste disposal company for the environmentally safe recycling and disposal of your device. 	

TRANSPORT AND STORAGE PRECAUTIONS	CAUTION
<ul style="list-style-type: none"> FX2N-10GM positioning controller is a precision instrument. During transportation, avoid impacts larger than those specified in Section 5.2. Failure to do so may cause failures in the FX2N-10GM positioning controller. After transportation, verify the operations of the FX2N-10GM positioning controller. 	

1. Reference manual

Refer to the under mentioned manual for details about product installation, and programming.

- 1) FX2N-10GM, FX2N-20GM HARDWARE PROGRAMMING MANUAL
The installation of FX2N-10GM and FX2N-20GM and wiring and the instructions are explained.
- 2) E-20TP-E OPERATION MANUAL
The operation of the input of the program which uses E-20TP-E and the monitor and the test is explained.
- 3) FX-PCS-VPS/WIN-E SOFTWARE MANUAL
The operation program is input using the FX-PCS-VPS/WIN-E software. This manual explains the operation of the monitor and test functions.
- 4) FX-PCS-KIT-GM-EE SOFTWARE MANUAL
The program is input via the FX-PCS-KIT-GM-EE. The manual explains the operation of the monitor and test functions.

The manual in 1) is not included with the product. Please request from the shop where the units was purchased if required.

The manuals in 2), 3) and 4) are included with the product.

2. Outline of the unit

The FX2N-10GM positioning controller (hereinafter call FX2N-10GM or 10GM) is a pulse chain output unit that enables the positioning control of a stepping motor or a servo motor via the drive unit.

- One FX2N-10GM can control 1 axis.
- Both dedicated positioning language (cod instructions) and sequence language (basic instructions and application instructions) are available.
- A pulse generator can be connection.(The manual pulse generators must be an open collector output type.)
- The zero return operation at each start can be omitted with a servo amplifier with the absolute position (ABS) detection function.
- The FX2N-10GM can be used alone.

When an FX2N-10GM is connected with an FX2N/FX2NC/FX3U/FX3UC series Programmable logic controller (here after call PLC), the positioning data can be read/written.

When connecting to an FX2NC PLC, the FX2NC-CNV-IF must be used.

When connecting to an FX3UC PLC, the FX2NC-CNV-IF or FX3UC-1PS-5V must be used.

3. External dimensions

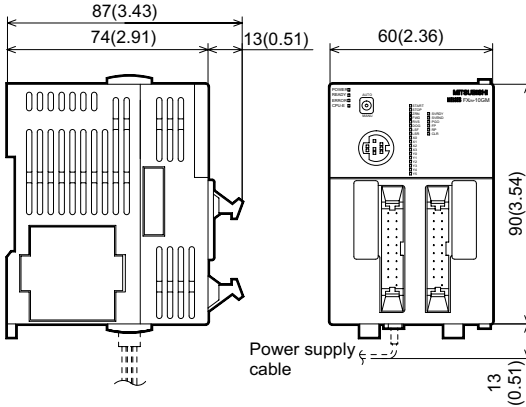

Din rail width: 35mm
Weight: approx.0.3kg
Dimensions mm(inch)

4. Product composition

4.1 Each part name

The name and description of each part of the FX₂N-10GM are explained below.

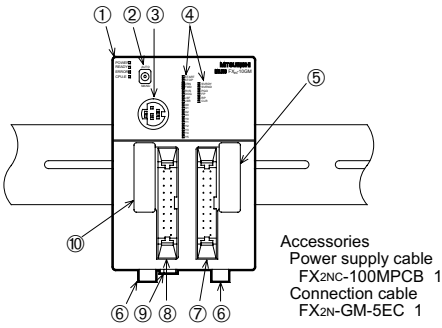

- ① Operation indicator LED
- ② MANU/AUTO switch
- ③ Connector for programming tool
- ④ I/O display
- ⑤ Connector for PLC extension block
- ⑥ Hook for DIN rail installation
- ⑦ Connector for motor amplifier: CON2
- ⑧ Connector for I/O: CON1
- ⑨ Connector for power supply
- ⑩ Connector for PLC

4.2 Operation display

The state of FX₂N-10GM is displayed by LED.

Name of LED	Content
POWER	LED lights when power is supplied. If LED is not lit, check power supply voltage and current.
READY	LED lights when accepting an axis instruction. During pulse output or when an error occurs, the LED is off.
ERROR	LED is lit or blinks when an error occurs in the positioning drive of FX ₂ N-10GM.
CPU-E	CPU error. Incompatible system configuration, excess noise, etc. (Mixing foreign body, and influence of noise, etc.)

4.3 I/O connector

The pin array of the I/O connector is as follows.

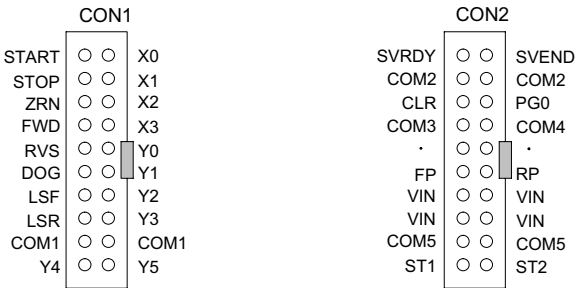

All terminals with identical names are shorted internally. (Ex. COM1-COM1, VIN-VIN, etc.)

Do not wire "•" terminals.

Refer to the FX₂N-10GM, FX₂N-20GM HARDWARE PROGRAMMING MANUAL for wiring information.

4.4 Power supply connector

The power to the FX₂N-10GM is supplied with the special power supply cable attached to the product. The ground of the FX₂N-10GM and the servo amplifier is a common ground. Refer to the FX₂N-10GM, FX₂N-20GM HARDWARE PROGRAMMING MANUAL for details wiring instruction.

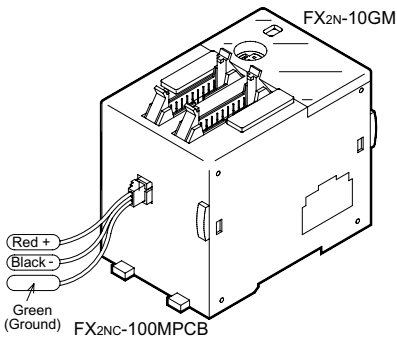

The pin number of the power supply connector of FX₂N-10GM

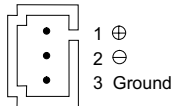

Install a safety circuit outside of FX₂N-10GM so that the entire system may work safety when the external power supply fails.

4.5 Connection with PLC

Refer to the FX₂N-10GM, FX₂N-20GM HARDWARE PROGRAMMING MANUAL for details concerning the system configuration.

5. Specification

5.1 Power supply specification

Item	Contents
Power supply	DC24V +10%, -15%
Allowance power failure time	The operation is continued to the momentary power failure is 5ms or less.
Power consumption	5W
Fuse	125V 1A

5.2 General specifications

Item	Contents
Ambient temperature	0 to 55 °C (operation). -20 to 70 °C (storage).
Surrounding humidity	35 to 85% (No condensation) operation
Vibration resistance	Frequency 10 to 57Hz : Half 0.035mm amplitude, Frequency 57 to 150Hz: 4.9 m/s ² Acceleration Sweep count for X,Y, Z: 10 times (80 min in each direction).
Shock resistance	147m/s ² acceleration, Action time: 11ms. 3 times in each direction X, Y, Z.
Noise immunity	1,000Vp-p, 1μs. 30 to 100Hz, tested by noise simulator.
Dielectric withstand voltage	500V AC > 1 min, tested between all points, terminal and ground.
Insulation resistance	5MΩ > 500V DC, tested between all points, terminal and ground
Ground	Class D grounding (100Ω or less)
Use atmosphere	Ambient conditions to be free of corrosive gases. Dust should be minimal.
Working altitude	<2000m ^{*1}

*1 Do not use the PLC under pressure higher than the atmospheric pressure. Doing so may damage the PLC.

5.3 Performance specification

Item	Contents
Number of control axes	One axis
Applicable PLC	Bus connection with FX2N/FX2NC/FX3U/FX3UC series PLC. The number of I/O points occupied is 8 points. When connecting to an FX2NC PLC, the FX2NC-CNV-IF must be used. When connecting to an FX3UC PLC, the FX2NC-CNV-IF or FX3UC-1PS-5V must be used.
Program memory	3.8 K steps. Built-in EEPROM
Battery	No battery included.
Positioning unit	Command units: mm, deg, inch, pls, (relativity/absolutely) Max command value ± 999,999 (32 bits when indirectly specifying)
Accumulation address	-2,147,483,648 to 2,147,483,647 pulses
Speed instruction	200kHz max., 153,000cm/min (200kHz or less). Automatic trapezoidal pattern acceleration/deceleration
Zero return	Manual operation or automatic operation. The DOG type machine zero return (The DOG search function is provided). An automatic electric zero return is possible by the electric starting point setting.
Absolute position detection	The absolute position detection is possible with MR-J2(S), MR-H and the MR-J3 type servo motors with the ABS detection function.
Control inputs	Operation system: FWD (manual forwarding), RVS (manual reversal) ZRN (machine zero return), START (automatic start), STOP, Manual pulse generator (2kHz max), Single-step operation input (Depends upon the parameter setting). Mechanical system: DOG (near-point signal), LSF (forward rotation limit), LSR (reverse rotation limit), Interrupt: 4 points Servo system: SVRDY (servo ready), SVEND (servo end), PG0 (zero-point signal) General purpose: The main body has X0 to X3.
Control outputs	Servo system: FP (forward rotation pulse). RP (reverse rotation pulse), CLR (counter clear). General purpose: The main body has Y0 to Y5.

* 1:When the file register is used, it is necessary to set PARA.101.

5.4 Input specifications

Item		Input from general-purpose equipment	Input from drive unit
Input signal name	Group 1	START, STOP, ZRN, FWD, RVS, LSF, LSR	SVRDY, SVEND
	Group 2	DOG	PG0
	Group 3	General-purpose input, interruption input: X0 to X3	-
	Group 4	Manual pulse generator	-
Circuit insulation		By photocoupler	By photocoupler
Operation indication		LED is lit while input is ON	LED is lit while input is ON
Signal voltage		24V DC \pm 10% (internal power supply)	5 to 24V DC \pm 10%
Input current		7mA/24V DC	7mA/24V DC (PG0 11.5mA/24V DC)
Input ON current		4.5mA or more	0.7mA or more (PG0 1.5mA or more)
Input OFF current		1.5mA or less	0.3mA or less (PG0 0.5mA or less)
Signal format		Contact input or NPN open collector transistor input.	
Response time	Group 1	Approx. 3msec	Approx.3msec
	Group 2	Approx. 0.5msec	Approx.16 μ s
	Group 3	Approx. 3msec ^{*1}	-
	Group 4	Approx. 0.1ms ^{*1}	-

*1: The selection of general purpose inputs, manual pulse generator inputs or interrupt inputs in the parameter settings automatically adjusts the input filters.

5.5 Output specification

Item	General-purpose output	Output to drive unit
Signal name	Y0 to Y5	FP, RP, CLR
Circuit isolation	By photocoupler	By photocoupler
Operation indication	LED is lit while output is ON	LED is lit while output is ON
External power supply	5 to 24V DC \pm 10%	5 to 24V DC \pm 10%
Load current	50mA or less	20mA or less
Open circuit leak current	0.1mA/24V DC or less	0.1mA/24V DC or less
Output ON voltage	0.5V max	0.5V max (CLR is 1.5V max.)
Response time	0.2ms max. for both OFF \rightarrow ON and ON \rightarrow OFF.	Pulse output FP RP is 200kHz max. Pulse output width of the CLR signal: Approx. 20msec.

This manual confers no industrial property rights or any rights of any other kind, nor does it confer any patent licenses. Mitsubishi Electric Corporation cannot be held responsible for any problems involving industrial property rights which may occur as a result of using the contents noted in this manual.

Warranty

Mitsubishi will not be held liable for damage caused by factors found not to be the cause of Mitsubishi; opportunity loss or lost profits caused by faults in the Mitsubishi products; damage, secondary damage, accident compensation caused by special factors unpredictable by Mitsubishi; damages to products other than Mitsubishi products; and to other duties.

For safe use

- This product has been manufactured as a general-purpose part for general industries, and has not been designed or manufactured to be incorporated in a device or system used in purposes related to human life.
- Before using the product for special purposes such as nuclear power, electric power, aerospace, medicine or passenger movement vehicles, consult with Mitsubishi Electric.
- This product has been manufactured under strict quality control. However when installing the product where major accidents or losses could occur if the product fails, install appropriate backup or failsafe functions in the system.

Manual number : JY992D77701

Manual revision : E

Date : May 2010

 **MITSUBISHI ELECTRIC CORPORATION**

HEAD OFFICE : TOKYO BUILDING, 2-7-3 MARUNOUCHI, CHIYODA-KU, TOKYO 100-8310, JAPAN
HIMEJI WORKS : 840, CHIYODA CHO, HIMEJI, JAPAN

FX2N

FX2N-10GM

USER'S GUIDE

JY992D77701E

This manual only describes the specifications for FX2N-10GM positioning controller.

For complete operation, wiring, mounting and programming instructions please refer to the FX2N-10GM, FX2N-20GM HARDWARE PROGRAMMING MANUAL, FX PROGRAMMING MANUAL II and FX SERIES HARDWARE MANUAL.

These manuals should be read and understood before attempting to install or use the unit.

And, store this manual in a safe place so that you can take it out and read it whenever necessary. Always forward it to the end user.

Safety Precaution (Read these precautions before use.)

This manual classifies the safety precautions into two categories: **⚠ DANGER** and **⚠ CAUTION**.

⚠ DANGER	Indicates that incorrect handling may cause hazardous conditions, resulting in death or severe injury.
⚠ CAUTION	Indicates that incorrect handling may cause hazardous conditions, resulting in medium or slight personal injury or physical damage.

Depending on the circumstances, procedures indicated by **⚠ CAUTION** may also cause severe injury. It is important to follow all precautions for personal safety

DESIGN PRECAUTIONS	⚠ DANGER
<ul style="list-style-type: none"> Install a safety circuit outside the PLC so that the entire system conservatively operates even if an abnormality occurs in the external power supply or a failure occurs in the PLC. If the safety circuit is installed inside the PLC, malfunction and erroneous output may cause accidents. 	

STARTUP AND MAINTENANCE PRECAUTIONS	⚠ DANGER
<ul style="list-style-type: none"> Do not touch any terminal while the FX2N-10GM positioning controller's power is on. Doing so may cause electric shock or malfunctions. Before cleaning or retightening terminals externally cut off all phases of the power supply. Failure to do so may cause electric shock. Thoroughly read the manual, sufficiently confirming safety, then perform returning to the zero point in the MANU/AUTO mode, jog operation, step operation or automatic operation. An operation error may damage the machinery or cause accidents. 	

STARTUP AND MAINTENANCE PRECAUTIONS	⚠ CAUTION
<ul style="list-style-type: none"> Do not disassemble or modify the FX2N-10GM positioning controller. Doing so may cause fire, equipment failures, or malfunctions. For repair, contact your local Mitsubishi Electric distributor. Turn off the power to the FX2N-10GM positioning controller before connecting or disconnecting any extension cable. Failure to do so may cause equipment failures or malfunctions. Turn off the power to the FX2N-10GM positioning controller before attaching or detaching the following devices. Failure to do so may cause equipment failures or malfunctions. <ul style="list-style-type: none"> Peripheral devices, FX Series terminal blocks 	

DISPOSAL PRECAUTIONS	⚠ CAUTION
<ul style="list-style-type: none"> Please contact a certified electronic waste disposal company for the environmentally safe recycling and disposal of your device. 	

TRANSPORT AND STORAGE PRECAUTIONS	⚠ CAUTION
<ul style="list-style-type: none"> FX2N-10GM positioning controller is a precision instrument. During transportation, avoid impacts larger than those specified in Section 5.2. Failure to do so may cause failures in the FX2N-10GM positioning controller. After transportation, verify the operations of the FX2N-10GM positioning controller. 	

1. Reference manual

Refer to the under mentioned manual for details about product installation, and programming.

- 1) FX2N-10GM, FX2N-20GM HARDWARE PROGRAMMING MANUAL
The installation of FX2N-10GM and FX2N-20GM and wiring and the instructions are explained.
- 2) E-20TP-E OPERATION MANUAL
The operation of the input of the program which uses E-20TP-E and the monitor and the test is explained.
- 3) FX-PCS-VPS/WIN-E SOFTWARE MANUAL
The operation program is input using the FX-PCS-VPS/WIN-E software. This manual explains the operation of the monitor and test functions.
- 4) FX-PCS-KIT-GM-EE SOFTWARE MANUAL
The program is input via the FX-PCS-KIT-GM-EE. The manual explains the operation of the monitor and test functions.

The manual in 1) is not included with the product. Please request from the shop where the units was purchased if required.

The manuals in 2), 3) and 4) are included with the product.

2. Outline of the unit

The FX2N-10GM positioning controller (hereinafter call FX2N-10GM or 10GM) is a pulse chain output unit that enables the positioning control of a stepping motor or a servo motor via the drive unit.

- One FX2N-10GM can control 1 axis.
- Both dedicated positioning language (cod instructions) and sequence language (basic instructions and application instructions) are available.
- A pulse generator can be connection.(The manual pulse generators must be an open collector output type.)
- The zero return operation at each start can be omitted with a servo amplifier with the absolute position (ABS) detection function.
- The FX2N-10GM can be used alone.
When an FX2N-10GM is connected with an FX2N/FX2NC/FX3U/FX3UC series Programmable logic controller (here after call PLC), the positioning data can be read/written.
When connecting to an FX2NC PLC, the FX2NC-CNV-IF must be used.
When connecting to an FX3UC PLC, the FX2NC-CNV-IF or FX3UC-1PS-5V must be used.

3. External dimensions

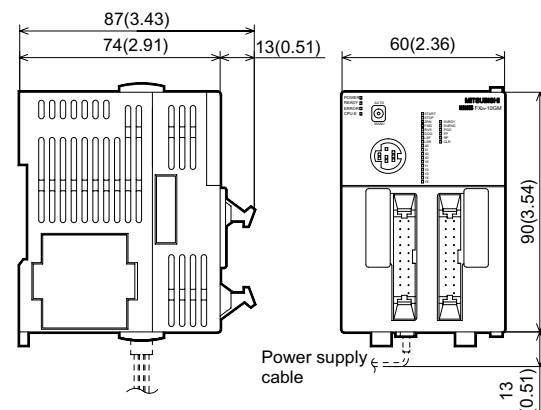

Din rail width: 35mm
Weight: approx.0.3kg
Dimensions mm(inch)

4. Product composition

4.1 Each part name

The name and description of each part of the FX2N-10GM are explained below.

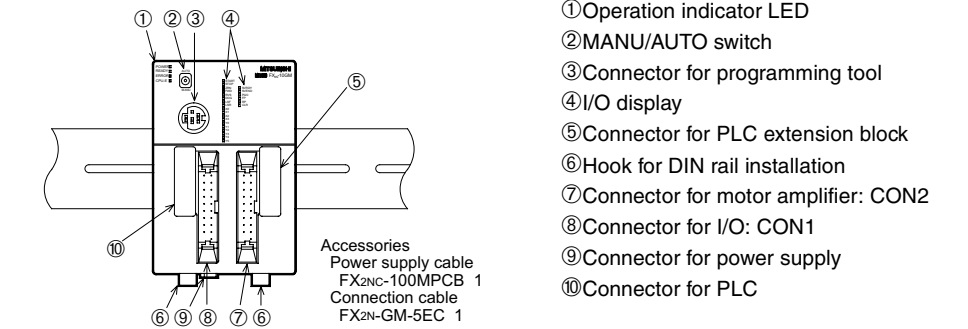

4.2 Operation display

The state of FX2N-10GM is displayed by LED.

Name of LED	Content
POWER	LED lights when power is supplied. If LED is not lit, check power supply voltage and current.
READY	LED lights when accepting an axis instruction. During pulse output or when an error occurs, the LED is off.
ERROR	LED is lit or blinks when an error occurs in the positioning drive of FX2N-10GM.
CPU-E	CPU error. Incompatible system configuration, excess noise, etc. (Mixing foreign body, and influence of noise, etc.)

4.3 I/O connector

The pin array of the I/O connector is as follows.

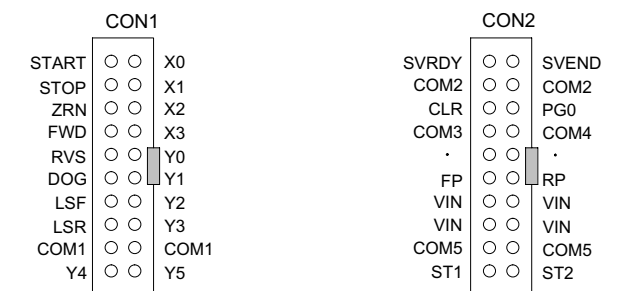

All terminals with identical names are shorted internally. (Ex. COM1-COM1, VIN-VIN, etc.)

Do not wire "•" terminals.

Refer to the FX2N-10GM, FX2N-20GM HARDWARE PROGRAMMING MANUAL for wiring information.

4.4 Power supply connector

The power to the FX2N-10GM is supplied with the special power supply cable attached to the product. The ground of the FX2N-10GM and the servo amplifier is a common ground. Refer to the FX2N-10GM, FX2N-20GM HARDWARE PROGRAMMING MANUAL for details wiring instruction.

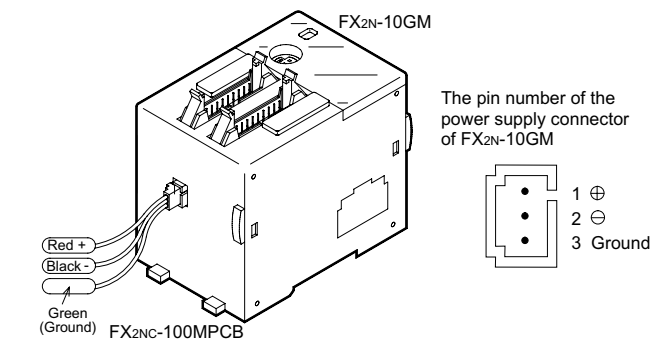

4.5 Connection with PLC

Refer to the FX2N-10GM, FX2N-20GM HARDWARE PROGRAMMING MANUAL for details concerning the system configuration.

5. Specification

5.1 Power supply specification

Item	Contents
Power supply	DC24V +10%, -15%
Allowance power failure time	The operation is continued to the momentary power failure is 5ms or less.
Power consumption	5W
Fuse	125V 1A

5.2 General specifications

Item	Contents
Ambient temperature	0 to 55 °C (operation). -20 to 70 °C (storage).
Surrounding humidity	35 to 85% (No condensation) operation
Vibration resistance	Frequency 10 to 57Hz : Half 0.035mm amplitude, Frequency 57 to 150Hz: 4.9 m/s ² Acceleration Sweep count for X, Y, Z: 10 times (80 min in each direction).
Shock resistance	147m/s ² acceleration, Action time: 11ms. 3 times in each direction X, Y, Z.
Noise immunity	1,000Vp-p, 1μs. 30 to 100Hz, tested by noise simulator.
Dielectric withstand voltage	500V AC > 1 min, tested between all points, terminal and ground.
Insulation resistance	5MΩ > 500V DC, tested between all points, terminal and ground
Ground	Class D grounding (100Ω or less)
Use atmosphere	Ambient conditions to be free of corrosive gases. Dust should be minimal.
Working altitude	<2000m ^{*1}

*1 Do not use the PLC under pressure higher than the atmospheric pressure. Doing so may damage the PLC.

5.3 Performance specification

Item	Contents
Number of control axes	One axis
Applicable PLC	Bus connection with FX2N/FX2NC/FX3U/FX3UC series PLC. The number of I/O points occupied is 8 points. When connecting to an FX2NC PLC, the FX2NC-CNV-IF must be used. When connecting to an FX3UC PLC, the FX2NC-CNV-IF or FX3UC-1PS-5V must be used.
Program memory	3.8 K steps. Built-in EEPROM
Battery	No battery included.
Positioning unit	Command units: mm, deg, inch, pls, (relativity/absolutely) Max command value ± 999,999 (32 bits when indirectly specifying)
Accumulation address	-2,147,483,648 to 2,147,483,647 pulses
Speed instruction	200kHz max., 153,000cm/min (200kHz or less). Automatic trapezoidal pattern acceleration/deceleration
Zero return	Manual operation or automatic operation. The DOG type machine zero return (The DOG search function is provided). An automatic electric zero return is possible by the electric starting point setting.
Absolute position detection	The absolute position detection is possible with MR-J2(S), MR-H and the MR-J3 type servo motors with the ABS detection function.
Control inputs	Operation system: FWD (manual forwarding), RVS (manual reversal) ZRN (machine zero return), START (automatic start), STOP, Manual pulse generator (2kHz max), Single-step operation input (Depends upon the parameter setting). Mechanical system: DOG (near-point signal), LSF (forward rotation limit), LSR (reverse rotation limit), Interrupt: 4 points Servo system: SVRDY (servo ready), SVEND (servo end), PG0 (zero-point signal) General purpose: The main body has X0 to X3.
Control outputs	Servo system: FP (forward rotation pulse), RP (reverse rotation pulse), CLR (counter clear). General purpose: The main body has Y0 to Y5.

* 1:When the file register is used, it is necessary to set PARA.101.

5.4 Input specifications

Item	Input from general-purpose equipment	Input from drive unit	
Input signal name	Group 1	START, STOP, ZRN, FWD, RVS, LSF, LSR	SVRDY, SVEND
	Group 2	DOG	PG0
	Group 3	General-purpose input, interruption input: X0 to X3	-
	Group 4	Manual pulse generator	-
Circuit insulation	By photocoupler	By photocoupler	
Operation indication	LED is lit while input is ON	LED is lit while input is ON	
Signal voltage	24V DC ± 10% (internal power supply)	5 to 24V DC ± 10%	
Input current	7mA/24V DC	7mA/24V DC (PG0 11.5mA/24V DC)	
Input ON current	4.5mA or more	0.7mA or more (PG0 1.5mA or more)	
Input OFF current	1.5mA or less	0.3mA or less (PG0 0.5mA or less)	
Signal format	Contact input or NPN open collector transistor input.		
Response time	Group 1	Approx. 3msec	Approx.3msec
	Group 2	Approx. 0.5msec	Approx.16μs
	Group 3	Approx. 3msec ^{*1}	-
	Group 4	Approx. 0.1ms ^{*1}	-

*1:The selection of general purpose inputs, manual pulse generator inputs or interrupt inputs in the parameter settings automatically adjusts the input filters.

5.5 Output specification

Item	General-purpose output	Output to drive unit
Signal name	Y0 to Y5	FP, RP, CLR
Circuit isolation	By photocoupler	By photocoupler
Operation indication	LED is lit while output is ON	LED is lit while output is ON
External power supply	5 to 24V DC ± 10%	5 to 24V DC ± 10%
Load current	50mA or less	20mA or less
Open circuit leak current	0.1mA/24V DC or less	0.1mA/24V DC or less
Output ON voltage	0.5V max	0.5V max (CLR is 1.5V max.)
Response time	0.2ms max. for both OFF→ON and ON → OFF.	Pulse output FP RP is 200kHz max. Pulse output width of the CLR signal: Approx. 20msec.

This manual confers no industrial property rights or any rights of any other kind, nor does it confer any patent licenses. Mitsubishi Electric Corporation cannot be held responsible for any problems involving industrial property rights which may occur as a result of using the contents noted in this manual.

Warranty

Mitsubishi will not be held liable for damage caused by factors found not to be the cause of Mitsubishi; opportunity loss or lost profits caused by faults in the Mitsubishi products; damage, secondary damage, accident compensation caused by special factors unpredictable by Mitsubishi; damages to products other than Mitsubishi products; and to other duties.

For safe use

- This product has been manufactured as a general-purpose part for general industries, and has not been designed or manufactured to be incorporated in a device or system used in purposes related to human life.
- Before using the product for special purposes such as nuclear power, electric power, aerospace, medicine or passenger movement vehicles, consult with Mitsubishi Electric.
- This product has been manufactured under strict quality control. However when installing the product where major accidents or losses could occur if the product fails, install appropriate backup or failsafe functions in the system.

Manual number : JY992D77701

Manual revision : E

Date : May 2010

 **MITSUBISHI ELECTRIC CORPORATION**

HEAD OFFICE : TOKYO BUILDING, 2-7-3 MARUNOUCHI, CHIYODA-KU, TOKYO 100-8310, JAPAN
HIMEJI WORKS : 840, CHIYODA CHO, HIMEJI, JAPAN

JY992D77701E

Effective May 2010
Specifications are subject to change without notice