

MITSUBISHI *Changes for the Better*
PROGRAMMABLE CONTROLLERS
MELSEC-F

FX3U-4LC

INSTALLATION MANUAL

Manual Number	JY997D38901
Revision	A
Date	December 2009

This manual describes the part names, dimensions, mounting, and specifications of the product. Before use, read this manual and the manuals of all relevant products fully to acquire proficiency in handling and operating the product. Make sure to learn all the product information, safety information, and precautions. Store this manual in a safe place so that it can be taken out and read whenever necessary. Always forward it to the end user. Registration: The company and product names described in this manual are registered trademarks or the trademarks of their respective companies. Effective December 2009. Specifications are subject to change without notice. © 2009 Mitsubishi Electric Corporation

Safety Precaution (Read these precautions before use.)

This manual classifies the safety precautions into two categories:

⚠ DANGER and **⚠ CAUTION**.

⚠ DANGER	Indicates that incorrect handling may cause hazardous conditions, resulting in death or severe injury.
⚠ CAUTION	Indicates that incorrect handling may cause hazardous conditions, resulting in medium or slight personal injury or physical damage.

Depending on the circumstances, procedures indicated by **⚠ CAUTION** may also cause severe injury. It is important to follow all precautions for personal safety.

Associated Manuals

Manual name	Manual No.	Description
FX3U-4LC User's Manual	JY997D38901 MODEL CODE: 09R625	Describes details of the FX3U-4LC temperature control block.
FX3G Series User's Manual - Hardware Edition	JY997D31301 MODEL CODE: 09R521	Explains the FX3G Series PLC specifications for I/O, wiring, installation, and maintenance.
FX3U Series User's Manual - Hardware Edition	JY997D16501 MODEL CODE: 09R516	Explains the FX3U Series PLC specifications for I/O, wiring, installation, and maintenance.
FX3UC Series User's Manual - Hardware Edition	JY997D28701 MODEL CODE: 09R519	Explains the FX3UC Series PLC specifications for I/O, wiring, installation, and maintenance.

How to obtain manuals

For product manuals or documents, consult with the Mitsubishi Electric dealer from whom you purchased your product.

Certification of UL, cUL standards

FX3U-4LC units comply with the UL standards (UL, cUL).

UL, cUL File Number: E95239

Regarding the standards that comply with the main unit, please refer to either the FX series product catalog or consult with your nearest Mitsubishi product provider.

Compliance with EC directive (CE Marking)

This note does not guarantee that an entire mechanical module produced in accordance with the contents of this note will comply with the following standards. Compliance to EMC directive and LVD directive for the entire mechanical module should be checked by the user / manufacturer. For more information please consult with your nearest Mitsubishi product provider.

Regarding the standards that comply with the main unit, please refer to either the FX series product catalog or consult with your nearest Mitsubishi product provider.

Requirement for Compliance with EMC directive

The following products have shown compliance through direct testing (of the identified standards below) and design analysis (through the creation of a technical construction file) to the European Directive for Electromagnetic Compatibility (2004/108/EC) when used as directed by the appropriate documentation.

Attention

- This product is designed for use in industrial applications.
- Manufactured by: Mitsubishi Electric Corporation
2-7-3 Marunouchi, Chiyoda-ku, Tokyo, 100-8310 Japan
- Manufactured at: Mitsubishi Electric Corporation Himeji Works
840 Chiyoda-machi, Himeji, Hyogo, 670-8677 Japan
- Authorized Representative in the European Community: Mitsubishi Electric Europe B.V.
Gothaer Str. 8, 40880 Ratingen, Germany

Type: Programmable Controller (Open Type Equipment)

Models: MELSEC FX3U series manufactured

from December 1st, 2009 FX3U-4LC

Standard	Remark
EN61131-2:2003 Programmable controllers - Equipment requirements and tests	Compliance with all relevant aspects of the standard. EMC • Radiated Emissions • Conducted Emissions EMS • Radiated electromagnetic field • Fast Transient burst • Electrostatic discharge • High-energy surge • Voltage drops and interruptions • Conducted RF • Power frequency magnetic field

Caution for EC Directive

The FX3U-4LC have been found to be compliant to the European standards in the aforesaid manual and directive. However, for the very best performance from what are in fact delicate measuring and controlled output device Mitsubishi Electric would like to make the following points;

As analog devices are sensitive by nature, their use should be considered carefully. For users of proprietary cables (integral with sensors or actuators), these users should follow those manufacturers installation requirements. Mitsubishi Electric recommend that shielded cables should be used. If NO other EMC protection is provided, then users may experience temporary loss or accuracy between ±10% in very heavy industrial areas.

However, Mitsubishi Electric suggest that if adequate EMC precautions are followed for the users complete control system, users should expect accuracy as specified in this manual.

- Sensitive analog cable should not be laid in the same trunking or cable conduit as high voltage cabling. Where possible users should run analog cables separately.
- Good cable shielding should be used. When terminating the shield at Earth - ensure that no earth loops are accidentally created.
- When reading analog values, EMC accuracy can be improved out by averaging the readings. This can be achieved either through functions on the analog special function blocks or through a users program in the FX3G/FX3U/FX3UC Series PLC main unit.
- Installation in Enclosure Programmable logic controllers are open-type devices that must be installed and used within conductive control cabinets. Please use the programmable logic controller while installed within a conductive shielded control cabinet. Please secure the cabinet door to the control cabinet (for conduction). Installation within a control cabinet greatly affects the safety of the system and aids in shielding noise from the programmable logic controller.

1. Introduction

The temperature control block FX3U-4LC (hereinafter called 4LC) equipped with 4 channel input (thermocouples, resistance thermometer and micro voltage input), 4 points output (open collector transistor) and 4 points CT input is a special function block for thermometer control. → For details, refer to the FX3U-4LC User's Manual.

1.1 Incorporated Items

Check to ensure the following product and items are included in the package

Included Item	
FX3U-4LC	1 unit
Special unit/block No. label	1 sheet
Dust proof protection sheet	1 sheet
Manuals (Japanese version, English version)	1 manual each

1.2 External Dimensions and Part Names

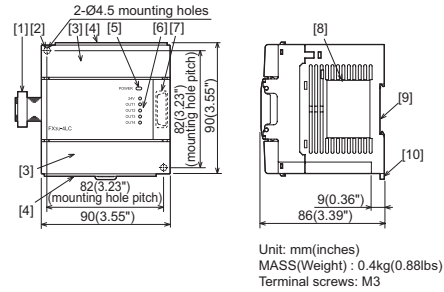

- | | |
|---|---|
| [1] Extension cable | [6] Status LEDs (Red) |
| [2] Direct mounting hole
2 holes of ϕ 4.5 (0.18")
(mounting screw: M4 screw) | [7] Extension connector |
| [3] Terminal block covers | [8] Nameplate |
| [4] Terminal cover | [9] DIN rail mounting groove
(DIN rail: DIN46277, 35mm
(1.38") width) |
| [5] Power LED (green) | [10] DIN rail mounting hook |

1.3 Power and status LEDs

LED display	LED color	Status	Description
POWER	Green	OFF	Power is not being supplied from the internal power supply (5V DC).
		ON	Power is being supplied from the internal power supply (5V DC).
24V	Red	OFF	Power is not being supplied from the external power supply (24V DC).
		ON	Power is being supplied from the external power supply (24V DC).
OUT1 to OUT4	Red	OFF	OUT1 to OUT4 output OFF
		ON	OUT1 to OUT4 output ON

1.4 Terminal Layout

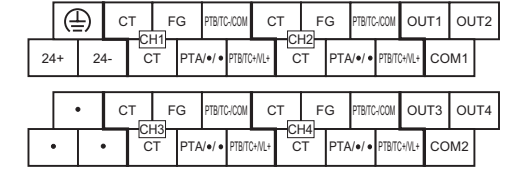

2. Installation

For installation details, refer to the following manuals. → Refer to the FX3U-4LC User's Manual.

INSTALLATION PRECAUTIONS **⚠ DANGER**

- Make sure to shut down all phases of the power supply externally before installing. Failure to do so may cause electric shock or damage to the product.

INSTALLATION PRECAUTIONS **⚠ CAUTION**

- Use the product within the generic environment specifications described in PLC main unit manual (Hardware Edition). Never use the product in areas with excessive dust, oily smoke, conductive dusts, corrosive gas (salt air, Cl₂, H₂S, SO₂, or NO₂), flammable gas, vibration or impacts, or expose it to high temperature, condensation, or rain and wind. If the product is used in such conditions, electric shock, fire, malfunctions, deterioration or damage may occur.
- Do not touch the conductive parts of the product directly. Doing so may cause device failures or malfunctions.
- Install the product securely using a DIN rail or mounting screws.
- Install the product on a flat surface. If the mounting surface is rough, undue force will be applied to the PC board, thereby causing nonconformities.
- When drilling screw holes or wiring, make sure that cutting and wiring debris do not enter the ventilation slits. Failure to do so may cause fire, equipment failures or malfunctions.
- Be sure to remove the dust proof sheet from the PLC's ventilation port when installation work is completed. Failure to do so may cause fire, equipment failures or malfunctions.
- Connect extension cables securely to their designated connectors. Loose connections may cause malfunctions.

2.1 Connection with PLC

The 4LC connects on the right side of a PLC main unit or extension units/blocks (including special function units/blocks). For connection to an FX3UC Series PLC or FX2NC Series PLC extension block, an FX2NC-CNV-IF or FX3UC-1PS-5V is required. For details, refer to the respective PLC manual. → Refer to the FX3G Series User's Manual - Hardware Edition. → Refer to the FX3U Series User's Manual - Hardware Edition. → Refer to the FX3UC Series User's Manual - Hardware Edition.

2.2 Mounting

The product is mounted by the following method.

- DIN rail mounting
- Direct mounting (mounting screw: M4 screw)

For details, refer to the respective PLC manual. → Refer to the FX3G Series User's Manual - Hardware Edition. → Refer to the FX3U Series User's Manual - Hardware Edition. → Refer to the FX3UC Series User's Manual - Hardware Edition.

3. Wiring

For wiring details, refer to the following manuals. → Refer to the FX3U-4LC User's Manual.

WIRING PRECAUTIONS **⚠ DANGER**

- Make sure to cut off all phases of the power supply externally before attempting wiring work. Failure to do so may cause electric shock.

WIRING PRECAUTIONS **CAUTION**

- Connect the AC power supply to the dedicated terminals specified in this manual. If an AC power supply is connected to a DC input/output terminal or DC power supply terminal, the PLC will burn out.
- Do not wire vacant terminals externally. Doing so may damage the product.
- Use class D grounding (grounding resistance of 100Ω or less) with a wire of 2mm² or thicker on the grounding terminal of the PLC. However, do not connect the ground terminal at the same point as a heavy electrical system.
- When drilling screw holes or wiring, make sure cutting or wire debris does not enter the ventilation slits. Failure to do so may cause fire, equipment failures or malfunctions.
- Make sure to observe the following precautions in order to prevent malfunctions under the influence of noise.
 - Do not bundle the power line or twisted shielded cable together with or lay it close to the main circuit, high-voltage line, or load line. Otherwise, noise disturbance and/or surge induction are likely to take place. As a guideline, lay the control line at least 100mm (3.94") or more away from the main circuit, high-voltage line, or load line.
 - Ground the shield wire or shield of the shielded cable at one point on the PLC. However, do not use common grounding with heavy electrical systems.
- Make sure to properly wire to the terminal blocks in accordance with the following precautions. Failure to do so may cause electric shock, a short-circuit, wire breakage, or damage to the product.
 - The disposal size of the cable end should follow the dimensions described in the FX3U-4LC User's Manual
 - Tightening torque should follow the specifications in the FX3U-4LC User's Manual

3.1 Example of input/output Wiring

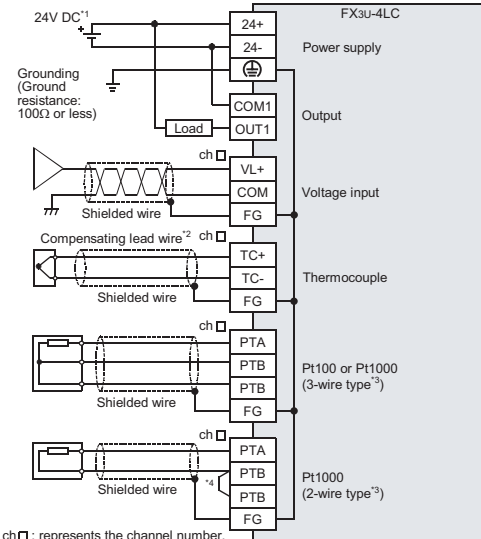

ch □ : represents the channel number.

*1 24V DC service power supply of the FX3G/FX3U Series PLC can also be used.

*2 When using a thermocouple, use specified compensating lead wires.

*3 When you use a resistance thermometer sensor, the resistance of the lead wire is low, use a wire without a resistance difference between the lead wire.

*4 Make sure to short-circuit the 'PTB' and 'PTB' terminals when a 2-wire resistance thermometer sensor is input.

3.2 Grounding

Ground the cables as follows

- The grounding resistance should be 100Ω or less.
- Independent grounding should be established whenever possible. Independent grounding should be performed for best results. When independent grounding is not configured, perform "shared grounding" as shown in the following figure. For details, refer to the respective PLC manual.
 - Refer to the FX3G Series User's Manual - Hardware Edition.
 - Refer to the FX3U Series User's Manual - Hardware Edition.
 - Refer to the FX3UC Series User's Manual - Hardware Edition.

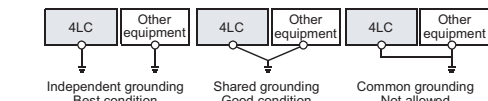

- The grounding point should be close to the 4LC, and all grounding wires should be as short as possible.

4. Specification

For details on specifications, refer to the following manual.

→ Refer to the FX3U-4LC User's Manual.

DESIGN PRECAUTIONS **DANGER**

- Make sure to include the following safety circuits outside the PLC to ensure safe system operation even during external power supply problems or PLC failure. Otherwise, malfunctions may cause serious accidents.
 - Above all, the following components should be included: an emergency stop circuit, a protection circuit, an interlock circuit for opposite movements (such as normal vs. reverse rotation), and an interlock circuit (to prevent damage to the equipment at the upper and lower positioning limits).
 - Note that when the PLC CPU detects an error, such as a watchdog timer error, during self-diagnosis, all outputs are turned off. Also, when an error that cannot be detected by the PLC CPU occurs in an input/output control block, output control may be disabled. External circuits and mechanisms should be designed to ensure safe machinery operation in such a case.
 - Note that when an error occurs in a relay, triac or transistor output device, the output could be held either on or off. For output signals that may lead to serious accidents, external circuits and mechanisms should be designed to ensure safe machinery operation in such a case.

DESIGN PRECAUTIONS **CAUTION**

- Do not bundle the control line together with or lay it close to the main circuit or power line. As a guideline, lay the control line at least 100mm (3.94") or more away from the main circuit or power line. Noise may cause malfunctions.
- Ground the shield wire or shield of the shielded cable at one point on the PLC. However, do not ground them at the same point as the high-voltage lines. Noise may cause malfunctions.
- Install module so that excessive force will not be applied to the terminal blocks. Failure to do so may result in wire damage/breakage or PLC failure.

DISPOSAL PRECAUTIONS **CAUTION**

- Please contact a certified electronic waste disposal company for the environmentally safe recycling and disposal of your device.

TRANSPORT AND STORAGE PRECAUTIONS **CAUTION**

- The product is a precision instrument. During transportation, avoid any impacts. Failure to do so may cause failures in the product. After transportation, verify the operations of the product.

4.1 Applicable PLC

Model name	Applicability
FX3G Series PLC	Ver. 1.00 and later (Up to 8 blocks can be extended)
FX3U Series PLC	Ver. 2.20 and later (Up to 8 blocks can be extended)
FX3UC Series PLC*1	Ver. 2.20 and later (Up to 8 blocks can be extended*2)

The version number can be checked by reading the last three digits of device D8001.

*1 An FX2NC-CNV-IF or FX3UC-1PS-5V is necessary to connect the 4LC with the FX3UC PLC.

*2 Up to 7 units can be connected to the FX3UC-32MT-LT-(2) PLC.

4.2 General Specifications

Items other than the following are equivalent to those of the PLC main unit.

For general specifications, refer to the manual of the PLC main unit.

→ Refer to the FX3G Series User's Manual - Hardware Edition.

→ Refer to the FX3U Series User's Manual - Hardware Edition.

→ Refer to the FX3UC Series User's Manual - Hardware Edition.

Item	Specification
Dielectric withstand voltage	500V AC for one minute
Insulation resistance	5MΩ or more by 500V DC megger

Between all terminals and ground terminal

4.3 Power Supply Specification

Item	Specification
Interface driving power supply	24V DC +20% -15% 50mA Connect a 24V DC power supply to the terminal block.
CPU driving power	5V DC 160mA 5V DC power is supplied internally from the main unit.

4.4 Performance Specification

Item	Specification
Control method	Two-position control, PID control, Heating/cooling PID control, Cascade control
Control operation period	250ms/4ch
Set temperature range	Refer to section 4.7
Heater disconnection detection	Alarm is detected by buffer memory (Variable within range from 0.0 to 100.0A.)
Operation mode	0 : Not used, 1 : Monitor, 2 : Monitor+Alarm, 3 : Monitor+Alarm+Control (Selected by buffer memory)
Self-diagnosis function	Adjustment data check, input value check, watch dog timer check.
Memory	Built-in EEPROM (Number of times of overwrite : 100,000 times)
Insulation method	<ul style="list-style-type: none"> The photocoupler is used to insulate the analog input area from the PLC. The DC/DC converter is used to insulate the power supply from the analog inputs. Channels are insulated from each other.
Number of I/O occupied points	8 points (Taken from either the input or output points of the PLC.)

4.5 Input Specification

Item	Specification	
Number of input points	4 points	
Input type*1	Thermocouple	K, J, R, S, E, T, B, N JIS C 1602-1995, PL11, W5Re/W26Re, U, L
	Resistance thermometer	3-wire type Pt100 JIS C 1604-1997, 3-wire type JPt100 JIS C 1604-1981 2-wire type/3-wire type Pt1000 JIS C 1604-1997
	Micro voltage input	
Measurement precision	When ambient temperature is 25°C±5 °C	K type thermocouple : When the input is in the range of 500 °C or more ±0.3% of full scale (±1digit) ²
	When ambient temperature is 0 to 55°C	K type thermocouple : When the input is in the range of 500 °C or more ±0.7% of full scale (±1digit) ²
Cold contact temperature compensation error	Within ±1.0 °C (When ambient temperature is 0 to 55°C) However, within ± 2.0 °C while input value is -150 to -100 °C / within ± 3.0 °C while input value is -200 to -150 °C	
Resolution	0.1°C (0.1°F), 1°C (1°F), 0.5μV or 5.0μV Varies depending on input range of used sensors.	
Sampling period	250ms/4ch	
Effect of external resistance (When thermocouple is used)	Approx. 0.125μV/Ω	
Effect of input lead wire resistance (When resistance thermometer is used)	3-wire type	Approx. 0.03%/Ω of full scale. 10Ω or less per 1-wire
	2-wire type	Approx. 0.04%/Ω of full scale. 7.5Ω or less per 1-wire
Input impedance	1MΩ or more	
Sensor current	Approx. 0.25mA (When resistance thermometer is used)	
Operation when input is disconnected/ Operation when input is short-circuited	Upscale/ Downscale (When resistance thermometer is used)	

*1 A different input can be selected for each channel.

*2 Measurement accuracy differs depending on the type of input, and the input range. For specification details, refer to the following manuals.

→ Refer to the FX3U-4LC User's Manual.

4.6 Current detector (CT) Input Specifications

Item	Specification
Number of input points	4 points
Current detector	CTL-12-S36-8, CTL-12-S56-10, CTL-6-P-H (manufactured by U.R.D. Co., Ltd.)
Heater current measured value	When CTL-12-S36-8 is used : 0.0 to 100.0A When CTL-12-S56-10 is used : 0.0 to 100.0A When CTL-6-P-H is used : 0.0 to 30.0A
Measurement precision	Larger one between ±5% of input value and ±2A (Excluding precision of current detector)
Sampling period	0.5 sec.

4.7 Set temperature range

Item	Specification
K	-200 to 1300°C (-100 to 2400°F)
J	-200 to 1200°C (-100 to 2100°F)
T	-200 to 400°C (-300 to 700°F)
S	0 to 1700°C (0 to 3200°F)
R	0 to 1700°C (0 to 3200°F)
E	-200 to 1000°C (0 to 1800°F)
B	0 to 1800°C (0 to 3000°F)
N	0 to 1300°C (0 to 2300°F)
PL11	0 to 1200°C (0 to 2300°F)
W5Re/W26Re	0 to 2300°C (0 to 3000°F)
U	-200 to 600°C (-300 to 700°F)
L	0 to 900°C (0 to 1600°F)
Micro voltage input	DC0 to 10mV, DC0 to 100mV
Pt100 (3-wire type)	-200 to 600°C (-300 to 1100°F)
JPt100 (3-wire type)	-200 to 500°C (-300 to 900°F)
Pt1000 (2-wire type/3-wire type)	-200.0 to 650.0°C (-328 to 1184°F)

4.8 Output Specification

Item	Specification
Number of output points	4 points
Output method	NPN open collector transistor output
Rated load voltage	5 to 24V DC
Maximum load voltage	30V DC or less
Maximum load current	100mA
Leak current in OFF status	0.1mA or less
ON voltage	1.5V (When the maximum load current)
Control output cycle	0.5 to 100.0 sec.

This manual confers no industrial property rights or any rights of any other kind, nor does it confer any patent licenses. Mitsubishi Electric Corporation cannot be held responsible for any problems involving industrial property rights which may occur as a result of using the contents noted in this manual.

Warning

Mitsubishi will not be held liable for damage caused by factors found not to be the cause of Mitsubishi; opportunity loss or lost profits caused by faults in the Mitsubishi products; damage, secondary damage, accident compensation caused by special factors unpredictable by Mitsubishi; damages to products other than Mitsubishi products; and to other duties.

For safe use

- This product has been manufactured as a general-purpose part for general industries, and has not been designed or manufactured to be incorporated in a device or system used in purposes related to human life.
- Before using the product for special purposes such as nuclear power, electric power, aerospace, medicine or passenger movement vehicles, consult with Mitsubishi Electric.
- This product has been manufactured under strict quality control. However when installing the product where major accidents or losses could occur if the product fails, install appropriate backup or failsafe functions in the system.

MITSUBISHI ELECTRIC CORPORATION

HEAD OFFICE : TOKYO BUILDING, 2-7-3 MARUNOUCHI, CHIYODA-KU, TOKYO 100-8310, JAPAN
HIMEJI WORKS : 840, CHIYODA CHO, HIMEJI, JAPAN

MITSUBISHI *Changes for the Better*
PROGRAMMABLE CONTROLLERS
MELSEC-F

FX3U-4LC
INSTALLATION MANUAL

Manual Number	JY997D38901
Revision	A
Date	December 2009

This manual describes the part names, dimensions, mounting, and specifications of the product. Before use, read this manual and the manuals of all relevant products fully to acquire proficiency in handling and operating the product. Make sure to learn all the product information, safety information, and precautions. Store this manual in a safe place so that it can be taken out and read whenever necessary. Always forward it to the end user.

Registration:
 The company and product names described in this manual are registered trademarks or the trademarks of their respective companies.

Effective December 2009
 Specifications are subject to change without notice.
 © 2009 Mitsubishi Electric Corporation

Safety Precaution (Read these precautions before use.)
 This manual classifies the safety precautions into two categories:
 ⚠️ DANGER and ⚠️ CAUTION.

DANGER	Indicates that incorrect handling may cause hazardous conditions, resulting in death or severe injury.
CAUTION	Indicates that incorrect handling may cause hazardous conditions, resulting in medium or slight personal injury or physical damage.

Depending on the circumstances, procedures indicated by ⚠️ CAUTION may also cause severe injury. It is important to follow all precautions for personal safety.

Associated Manuals

Manual name	Manual No.	Description
FX3U-4LC User's Manual	JY997D39101 MODEL CODE: 09R625	Describes details of the FX3U-4LC temperature control block.
FX3G Series User's Manual - Hardware Edition	JY997D31301 MODEL CODE: 09R521	Explains the FX3G Series PLC specifications for I/O, wiring, installation, and maintenance.
FX3U Series User's Manual - Hardware Edition	JY997D16501 MODEL CODE: 09R516	Explains the FX3U Series PLC specifications for I/O, wiring, installation, and maintenance.
FX3UC Series User's Manual - Hardware Edition	JY997D28701 MODEL CODE: 09R519	Explains the FX3UC Series PLC specifications for I/O, wiring, installation, and maintenance.

How to obtain manuals
 For product manuals or documents, consult with the Mitsubishi Electric dealer from who you purchased your product.

Certification of UL, cUL standards
 FX3U-4LC units comply with the UL standards (UL, cUL).
 UL, cUL File Number: E95239
 Regarding the standards that comply with the main unit, please refer to either the FX series product catalog or consult with your nearest Mitsubishi product provider.

Compliance with EC directive (CE Marking)
 This note does not guarantee that an entire mechanical module produced in accordance with the contents of this note will comply with the following standards. Compliance to EMC directive and LVD directive for the entire mechanical module should be checked by the user / manufacturer. For more information please consult with your nearest Mitsubishi product provider.

Regarding the standards that comply with the main unit, please refer to either the FX series product catalog or consult with your nearest Mitsubishi product provider.

Requirement for Compliance with EMC directive
 The following products have shown compliance through direct testing (of the identified standards below) and design analysis (through the creation of a technical construction file) to the European Directive for Electromagnetic Compatibility (2004/108/EC) when used as directed by the appropriate documentation.

- Attention**
- This product is designed for use in industrial applications.
 - Manufactured by: Mitsubishi Electric Corporation, 2-7-3 Marunouchi, Chiyoda-ku, Tokyo, 100-8310 Japan
 - Manufactured at: Mitsubishi Electric Corporation Himeji Works, 840 Chiyoda-machi, Himeji, Hyogo, 670-8677 Japan
 - Authorized Representative in the European Community: Mitsubishi Electric Europe B.V., Gothaer Str. 8, 40880 Ratingen, Germany

Type: Programmable Controller (Open Type Equipment)
 Models: MELSEC FX3U series manufactured from December 1st, 2009 FX3U-4LC

Standard	Remark
EN61131-2:2003 Programmable controllers - Equipment requirements and tests	Compliance with all relevant aspects of the standard.
	EMI
	• Radiated Emissions
	• Conducted Emissions
	EMS
	• Radiated electromagnetic field
	• Fast Transient burst
	• Electrostatic discharge
	• High-energy surge
	• Voltage drops and interruptions
	• Conducted RF
	• Power frequency magnetic field

Caution for EC Directive
 The FX3U-4LC have been found to be compliant to the European standards in the aforesaid manual and directive. However, for the very best performance from what are in fact delicate measuring and controlled output device Mitsubishi Electric would like to make the following points:
 As analog devices are sensitive by nature, their use should be considered carefully. For users of proprietary cables (integral with sensors or actuators), these users should follow those manufacturers installation requirements. Mitsubishi Electric recommend that shielded cables should be used. If NO other EMC protection is provided, then users may experience temporary loss or accuracy between ±10% in very heavy industrial areas.
 However, Mitsubishi Electric suggest that if adequate EMC precautions are followed for the users complete control system, users should expect accuracy as specified in this manual.

- Sensitive analog cable should not be laid in the same trunking or cable conduit as high voltage cabling. Where possible users should run analog cables separately.
- Good cable shielding should be used. When terminating the shield at Earth - ensure that no earth loops are accidentally created.
- When reading analog values, EMC accuracy can be improved out by averaging the readings. This can be achieved either through functions on the analog special function blocks or through a users program in the FX3G/FX3U/FX3UC Series PLC main unit.
- Installation in Enclosure
 Programmable logic controllers are open-type devices that must be installed and used within conductive control cabinets. Please use the programmable logic controller while installed within a conductive shielded control cabinet. Please secure the cabinet door to the control cabinet (for conduction). Installation within a control cabinet greatly affects the safety of the system and aids in shielding noise from the programmable logic controller.

1. Introduction
 The temperature control block FX3U-4LC (hereinafter called 4LC) equipped with 4 channel input (thermocouples, resistance thermometer and micro voltage input), 4 points output (open collector transistor) and 4 points CT input is a special function block for thermometer control.
 → For details, refer to the FX3U-4LC User's Manual.

1.1 Incorporated Items
 Check to ensure the following product and items are included in the package

Included Item	Quantity
FX3U-4LC	1 unit
Special unit/block No. label	1 sheet
Dust proof protection sheet	1 sheet
Manuals (Japanese version, English version)	1 manual each

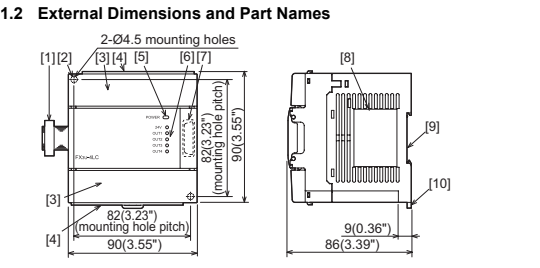

- | | |
|---|---|
| [1] Extension cable | [6] Status LEDs (Red) |
| [2] Direct mounting hole
2 holes of $\phi 4.5$ (0.18")
(mounting screw: M4 screw) | [7] Extension connector |
| [3] Terminal block covers | [8] Nameplate |
| [4] Terminal cover | [9] DIN rail mounting groove
(DIN rail: DIN46277, 35mm
(1.38") width) |
| [5] Power LED (green) | [10] DIN rail mounting hook |

1.3 Power and status LEDs

LED display	LED color	Status	Description
POWER	Green	OFF	Power is not being supplied from the internal power supply (5V DC).
		ON	Power is being supplied from the internal power supply (5V DC).
24V	Red	OFF	Power is not being supplied from the external power supply (24V DC).
		ON	Power is being supplied from the external power supply (24V DC).
OUT1 to OUT4	Red	OFF	OUT1 to OUT4 output OFF
		ON	OUT1 to OUT4 output ON

1.3 Power and status LEDs
 For wiring details, refer to the following manuals.
 → Refer to the FX3U-4LC User's Manual.

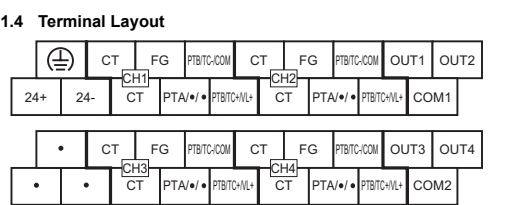

2. Installation
 For installation details, refer to the following manuals.
 → Refer to the FX3U-4LC User's Manual.

INSTALLATION PRECAUTIONS ⚠️ DANGER

- Make sure to shut down all phases of the power supply externally before installing. Failure to do so may cause electric shock or damage to the product.

INSTALLATION PRECAUTIONS ⚠️ CAUTION

- Use the product within the generic environment specifications described in PLC main unit manual (Hardware Edition). Never use the product in areas with excessive dust, oily smoke, conductive dusts, corrosive gas (salt air, Cl₂, H₂S, SO₂, or NO₂), flammable gas, vibration or impacts, or expose it to high temperature, condensation, or rain and wind.
- If the product is used in such conditions, electric shock, fire, malfunctions, deterioration or damage may occur.
- Do not touch the conductive parts of the product directly. Doing so may cause device failures or malfunctions.
- Install the product securely using a DIN rail or mounting screws.
- Install the product on a flat surface. If the mounting surface is rough, undue force will be applied to the PC board, thereby causing nonconformities.
- When drilling screw holes or wiring, make sure that cutting and wiring debris do not enter the ventilation slits. Failure to do so may cause fire, equipment failures or malfunctions.
- Be sure to remove the dust proof sheet from the PLC's ventilation port when installation work is completed. Failure to do so may cause fire, equipment failures or malfunctions.
- Connect extension cables securely to their designated connectors. Loose connections may cause malfunctions.

2.1 Connection with PLC
 The 4LC connects on the right side of a PLC main unit or extension units/blocks (including special function units/blocks).
 For connection to an FX3UC Series PLC or FX2NC Series PLC extension block, an FX2NC-CNV-IF or FX3UC-1PS-5V is required.
 For details, refer to the respective PLC manual.
 → Refer to the FX3G Series User's Manual - Hardware Edition.
 → Refer to the FX3U Series User's Manual - Hardware Edition.
 → Refer to the FX3UC Series User's Manual - Hardware Edition.

2.2 Mounting
 The product is mounted by the following method.

- DIN rail mounting
- Direct mounting (mounting screw: M4 screw)

For details, refer to the respective PLC manual.
 → Refer to the FX3G Series User's Manual - Hardware Edition.
 → Refer to the FX3U Series User's Manual - Hardware Edition.
 → Refer to the FX3UC Series User's Manual - Hardware Edition.

3. Wiring
 For wiring details, refer to the following manuals.
 → Refer to the FX3U-4LC User's Manual.

WIRING PRECAUTIONS ⚠️ DANGER

- Make sure to cut off all phases of the power supply externally before attempting wiring work. Failure to do so may cause electric shock.

WIRING PRECAUTIONS ⚠️ CAUTION

- Connect the AC power supply to the dedicated terminals specified in this manual. If an AC power supply is connected to a DC input/output terminal or DC power supply terminal, the PLC will burn out.
- Do not wire vacant terminals externally. Doing so may damage the product.
- Use class D grounding (grounding resistance of 100Ω or less) with a wire of 2mm² or thicker on the grounding terminal of the PLC. However, do not connect the ground terminal at the same point as a heavy electrical system.
- When drilling screw holes or wiring, make sure cutting or wire debris does not enter the ventilation slits. Failure to do so may cause fire, equipment failures or malfunctions.
- Make sure to observe the following precautions in order to prevent malfunctions under the influence of noise.
 - Do not bundle the power line or twisted shielded cable together with or lay it close to the main circuit, high-voltage line, or load line. Otherwise, noise disturbance and/or surge induction are likely to take place. As a guideline, lay the control line at least 100mm (3.94") or more away from the main circuit, high-voltage line, or load line.
 - Ground the shield wire or shield of the shielded cable at one point on the PLC. However, do not use common grounding with heavy electrical systems.
- Make sure to properly wire to the terminal blocks in accordance with the following precautions. Failure to do so may cause electric shock, a short-circuit, wire breakage, or damage to the product.
 - The disposal size of the cable end should follow the dimensions described in the FX3U-4LC User's Manual
 - Tightening torque should follow the specifications in the FX3U-4LC User's Manual

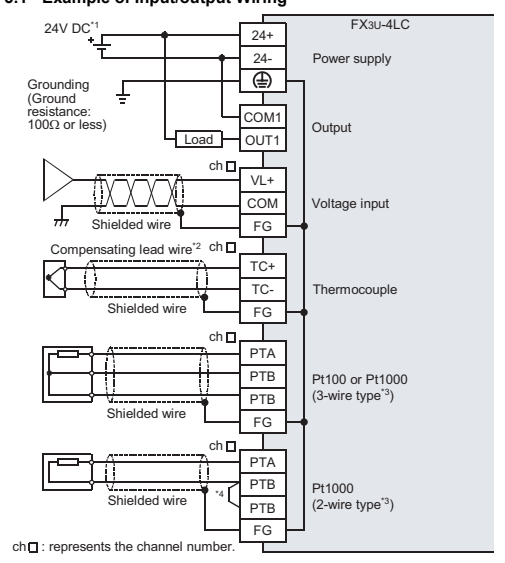

- ch □ : represents the channel number.
- *1 24V DC service power supply of the FX3G/FX3U Series PLC can also be used.
- *2 When using a thermocouple, use specified compensating lead wires.
- *3 When you use a resistance thermometer sensor, the resistance of the lead wire is low, use a wire without a resistance difference between the lead wire.
- *4 Make sure to short-circuit the 'PTB' and 'PTB' terminals when a 2-wire resistance thermometer sensor is input.

3.2 Grounding
 Ground the cables as follows

- The grounding resistance should be 100Ω or less.
- Independent grounding should be established whenever possible. Independent grounding should be performed for best results. When independent grounding is not configured, perform "shared grounding" as shown in the following figure. For details, refer to the respective PLC manual.
 → Refer to the FX3G Series User's Manual - Hardware Edition.
 → Refer to the FX3U Series User's Manual - Hardware Edition.
 → Refer to the FX3UC Series User's Manual - Hardware Edition.

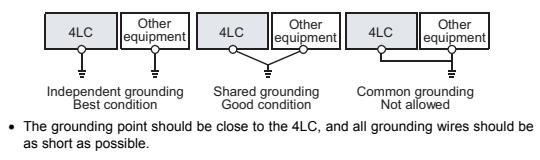

The grounding point should be close to the 4LC, and all grounding wires should be as short as possible.

4. Specification
 For details on specifications, refer to the following manual.
 → Refer to the FX3U-4LC User's Manual.

DESIGN PRECAUTIONS ⚠️ DANGER

- Make sure to include the following safety circuits outside the PLC to ensure safe system operation even during external power supply problems or PLC failure. Otherwise, malfunctions may cause serious accidents.
 - Above all, the following components should be included: an emergency stop circuit, a protection circuit, an interlock circuit for opposite movements (such as normal vs. reverse rotation), and an interlock circuit (to prevent damage to the equipment at the upper and lower positioning limits).
 - Note that when the PLC CPU detects an error, such as a watchdog timer error, during self-diagnosis, all outputs are turned off. Also, when an error that cannot be detected by the PLC CPU occurs in an input/output control block, output control may be disabled. External circuits and mechanisms should be designed to ensure safe machinery operation in such a case.
 - Note that when an error occurs in a relay, triac or transistor output device, the output could be held either on or off. For output signals that may lead to serious accidents, external circuits and mechanisms should be designed to ensure safe machinery operation in such a case.

DESIGN PRECAUTIONS ⚠️ CAUTION

- Do not bundle the control line together with or lay it close to the main circuit or power line. As a guideline, lay the control line at least 100mm (3.94") or more away from the main circuit or power line. Noise may cause malfunctions.
- Ground the shield wire or shield of the shielded cable at one point on the PLC. However, do not ground them at the same point as the high-voltage lines. Noise may cause malfunctions.
- Install module so that excessive force will not be applied to the terminal blocks. Failure to do so may result in wire damage/breakage or PLC failure.

DISPOSAL PRECAUTIONS ⚠️ CAUTION

- Please contact a certified electronic waste disposal company for the environmentally safe recycling and disposal of your device.

TRANSPORT AND STORAGE PRECAUTIONS ⚠️ CAUTION

- The product is a precision instrument. During transportation, avoid any impacts. Failure to do so may cause failures in the product. After transportation, verify the operations of the product.

4.1 Applicable PLC

Model name	Applicability
FX3G Series PLC	Ver. 1.00 and later (Up to 8 blocks can be extended)
FX3U Series PLC	Ver. 2.20 and later (Up to 8 blocks can be extended)
FX3UC Series PLC ^{*1}	Ver. 2.20 and later (Up to 8 blocks can be extended ^{*2})

The version number can be checked by reading the last three digits of device D8001.

- *1 An FX2NC-CNV-IF or FX3UC-1PS-5V is necessary to connect the 4LC with the FX3UC PLC.
- *2 Up to 7 units can be connected to the FX3UC-32MT-LT(-2) PLC.

4.2 General Specifications
 Items other than the following are equivalent to those of the PLC main unit. For general specifications, refer to the manual of the PLC main unit.
 → Refer to the FX3G Series User's Manual - Hardware Edition.
 → Refer to the FX3U Series User's Manual - Hardware Edition.
 → Refer to the FX3UC Series User's Manual - Hardware Edition.

Item	Specification
Dielectric withstand voltage	500V AC for one minute
Insulation resistance	5MΩ or more by 500V DC megger

Between all terminals and ground terminal

4.3 Power Supply Specification

Item	Specification
Interface driving power supply	24V DC +20% -15% 50mA Connect a 24V DC power supply to the terminal block.
CPU driving power	5V DC 160mA 5V DC power is supplied internally from the main unit.

4.4 Performance Specification

Item	Specification
Control method	Two-position control, PID control, Heating/cooling PID control, Cascade control
Control operation period	250ms/4ch
Set temperature range	Refer to section 4.7
Heater disconnection detection	Alarm is detected by buffer memory (Variable within range from 0.0 to 100.0A.)
Operation mode	0 : Not used, 1 : Monitor, 2 : Monitor+Alarm, 3 : Monitor+Alarm+Control (Selected by buffer memory)
Self-diagnosis function	Adjustment data check, input value check, watch dog timer check.
Memory	Built-in EEPROM (Number of times of overwrite : 100,000 times)
Insulation method	<ul style="list-style-type: none"> The photocoupler is used to insulate the analog input area from the PLC. The DC/DC converter is used to insulate the power supply from the analog inputs. Channels are insulated from each other.
Number of I/O occupied points	8 points (Taken from either the input or output points of the PLC.)

4.5 Input Specification

Item	Specification	
Number of input points	4 points	
Input type ^{*1}	Thermocouple	K, J, R, S, E, T, B, N JIS C 1602-1995, PLII, W5Re/W26Re, U, L
	Resistance thermometer	3-wire type Pt100 JIS C 1604-1997, 3-wire type JPt100 JIS C 1604-1981 2-wire type/3-wire type Pt1000 JIS C 1604-1997
	Micro voltage input	
Measurement precision	When ambient temperature is 25°C±5°C	K type thermocouple : When the input is in the range of 500°C or more ±0.3% of full scale (±1digit) ²
	When ambient temperature is 0 to 55°C	K type thermocouple : When the input is in the range of 500°C or more ±0.7% of full scale (±1digit) ²
Cold contact temperature compensation error	Within ±1.0°C (When ambient temperature is 0 to 55°C)	However, within ±2.0°C while input value is -150 to -100°C / within ±3.0°C while input value is -200 to -150°C
	Resolution	0.1°C (0.1°F), 1°C (1°F), 0.5μV or 5.0μV Varies depending on input range of used sensors.
Sampling period	250ms/4ch	
Effect of external resistance (When thermocouple is used)	Approx. 0.125μV/Ω	
Effect of input lead wire resistance (When resistance thermometer is used)	3-wire type	Approx. 0.03%/Ω of full scale. 10Ω or less per 1-wire
	2-wire type	Approx. 0.04%/Ω of full scale. 7.5Ω or less per 1-wire
Input impedance	1MΩ or more	
Sensor current	Approx. 0.25mA (When resistance thermometer is used)	
Operation when input is disconnected/ Operation when input is short-circuited	Upscale/ Downscale (When resistance thermometer is used)	

*1 A different input can be selected for each channel.
 *2 Measurement accuracy differs depending on the type of input, and the input range. For specification details, refer to the following manuals.
 → Refer to the FX3U-4LC User's Manual.

4.6 Current detector (CT) Input Specifications

Item	Specification
Number of input points	4 points
Current detector	CTL-12-S36-8, CTL-12-S56-10, CTL-6-P-H (manufactured by U.R.D. Co., Ltd.)
Heater current measured value	When CTL-12-S36-8 is used : 0.0 to 100.0A When CTL-12-S56-10 is used : 0.0 to 100.0A When CTL-6-P-H is used : 0.0 to 30.0A
Measurement precision	Larger one between ±5% of input value and ±2A (Excluding precision of current detector)
Sampling period	0.5 sec.

4.7 Set temperature range

Item	Specification
K	-200 to 1300°C (-100 to 2400°F)
J	-200 to 1200°C (-100 to 2100°F)
T	-200 to 400°C (-300 to 700°F)
S	0 to 1700°C (0 to 3200°F)
R	0 to 1700°C (0 to 3200°F)
E	-200 to 1000°C (0 to 1800°F)
B	0 to 1800°C (0 to 3000°F)
N	0 to 1300°C (0 to 2300°F)
PLII	0 to 1200°C (0 to 2300°F)
W5Re/W26Re	0 to 2300°C (0 to 3000°F)
U	-200 to 600°C (-300 to 700°F)
L	0 to 900°C (0 to 1600°F)
Micro voltage input	DC0 to 10mV, DC0 to 100mV
Pt100 (3-wire type)	-200 to 600°C (-300 to 1100°F)
JPt100 (3-wire type)	-200 to 500°C (-300 to 900°F)
Pt1000 (2-wire type/3-wire type)	-200.0 to 650.0°C (-328 to 1184°F)

4.8 Output Specification

Item	Specification
Number of output points	4 points
Output method	NPN open collector transistor output
Rated load voltage	5 to 24V DC
Maximum load voltage	30V DC or less
Maximum load current	100mA
Leak current in OFF status	0.1mA or less
ON voltage	1.5V (When the maximum load current)
Control output cycle	0.5 to 100.0 sec.

This manual confers no industrial property rights or any rights of any other kind, nor does it confer any patent licenses. Mitsubishi Electric Corporation cannot be held responsible for any problems involving industrial property rights which may occur as a result of using the contents noted in this manual.

Warranty
 Mitsubishi will not be held liable for damage caused by factors found not to be the cause of Mitsubishi; opportunity loss or lost profits caused by faults in the Mitsubishi products; damage, secondary damage, accident compensation caused by special factors unpredictable by Mitsubishi; damages to products other than Mitsubishi products; and to other duties.

For safe use

- This product has been manufactured as a general-purpose part for general industries, and has not been designed or manufactured to be incorporated in a device or system used in purposes related to human life.
- Before using the product for special purposes such as nuclear power, electric power, aerospace, medicine or passenger movement vehicles, consult with Mitsubishi Electric.
- This product has been manufactured under strict quality control. However when installing the product where major accidents or losses could occur if the product fails, install appropriate backup or failsafe functions in the system.